

Restricted

INSTRUCTION BOOK

FOR

Model TBK-20

RADIO TRANSMITTING EQUIPMENT

FREQUENCY RANGE

2,000 to 18,100 Kilocycles

TYPE OF EMISSION AND NOMINAL RATINGS

CW Telegraph Transmission
500 Watts

Frequency Range
2,000 to 18,100 Kcs.

With Power Amplifier Disconnected
CW Telegraph Transmission
75 Watts

Frequency Range
2,000 to 9,050 Kcs.

RESTRICTED

This document contains information affecting the National Defense of the United States within the meaning of the Espionage ACT (U.S.C. 50:31, 32). The transmission of this document or the revelation of its contents in any manner to any unauthorized person is prohibited.

This instruction book is furnished for the information of commissioned, warranted, enlisted and civilian personnel of the Navy whose duties involve design, instruction, operation and installation of radio and sound equipment. The word "RESTRICTED" as applied to this instruction book signifies that this instruction book is to be read only by the above personnel and that the contents of it should not be made known to persons not connected with the Navy.

*Manufactured for U. S. Navy Department
Bureau of Ships*

*Under
Contract NXsr-51573
Dated March 14, 1944*

By
WESTINGHOUSE ELECTRIC AND MANUFACTURING COMPANY
Radio Division **Baltimore, Maryland**

SPECIAL NOTE

In the preparation of this preliminary instruction book for Navy Model TBK-20 equipments, certain illustrations as listed below have been omitted. The instruction book in its final form will contain all the missing information.

1. Figures 2-13.
2. All Plans for Record Drawings.

Electric Shock

FIRST AID TREATMENT

Safety First—Regard electrical apparatus generally, and especially all current-carrying parts, as dangerous, irrespective of voltage. Exercise great care in handling, and avoid broad contacts such as are made by standing on a metal deck or in water.

Dangerous contact may result through lessened resistance when the skin and clothing are wet with perspiration. Contact with damp metal surfaces—decks, bulkheads, guns, machinery—may allow the current to ground through the moist skin and body.

Electric shock is due to current passing through the body—current actually passing—irrespective of the voltage. A pressure as low as 110 volts has caused death. Current passing through the body in the region of the heart is especially dangerous. In using electric breast drills avoid the possibility of a ground.

Usually electric shock does not kill instantly. Life can often be saved even though breathing has stopped.

1. Free the Victim from the Circuit Immediately. Use a dry non conductor (rubber gloves, clothing, rope, board) to move either the victim or the wire. Beware of using metal or moist material.

Shut off the current.

If necessary to cut a live wire, use an ax or hatchet with a dry wooden handle; turn your face away from the electrical flash.

2. Attend Instantly to the Victim's Breathing. Begin resuscitation at once on the spot. Do not stop to loosen clothing; every moment counts.

Resuscitation by the Prone Pressure Method of Artificial Respiration

GAS ASPHYXIATION—ELECTRIC SHOCK—DROWNING

Waste no time. When the patient is removed from the water, gas, smoke, or electric contact, get to work at once with your own hands. Send for the medical officer or nearest physician.

No reliance should be placed upon any special me-

chanical apparatus, as it is frequently out of order and often is not available when most needed. The patient's mouth should be cleared of any obstruction such as chewing gum or tobacco, false teeth, or mucus, so that there is no interference with the entrance and escape of air.

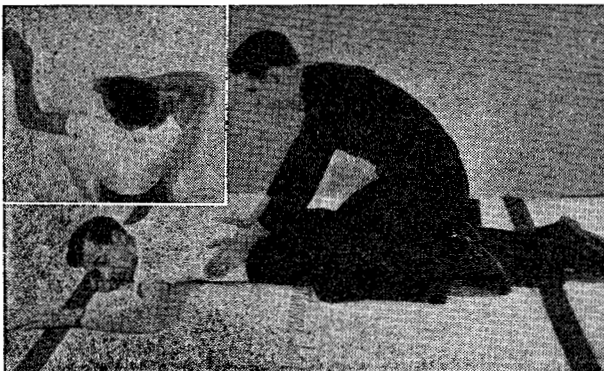

FIG. 1

Position—Lay the patient on his belly, one arm extended directly overhead, the other arm bent at elbow and with the face turned outward and resting on hand or forearm, so that the nose and mouth are free for breathing. (See Inset Fig. 1.)

Kneel straddling the patient's thighs with your knees placed at such a distance from the hip bones as will allow you to assume the position shown in Figure 1.

Place the palms of the hands on the small of the back with fingers resting on the ribs, the little finger just touching the lowest rib, with the thumb and fingers in a natural position, and the tips of the fingers just out of sight. (See Fig. 1.)

Table of Contents

	Page
Cover Sheet.....	i
Title Page.....	iii
Rules for Resuscitation.....	v
Warning.....	vi
Table of Contents.....	viii
Index to Illustrations.....	x
List of Plans for Record Drawings.....	xi
Contractual Guarantee.....	xii
Instructions to Operating Personnel Regarding Report of Failure.....	1-1
I. INTRODUCTION	1-1
A. Transmitter	1-1
B. Power Equipment.....	1-1
C. Weights and Dimensions.....	1-2
II. DESCRIPTION	2-1
TRANSMITTER	2-1
A. General	2-1
B. Terminal Board and Relay Section.....	2-2
C. Master Oscillator.....	2-2
D. First Intermediate Amplifier.....	2-4
E. Second Intermediate Amplifier.....	2-5
F. Power Amplifier.....	2-5
G. Antenna Tuning and Coupling Section.....	2-5
H. Power and Control Switches.....	2-6
POWER EQUIPMENT	2-7
A. Motor-Generator	2-7
Main Plate Generator Type CAY-21680.....	2-7
Master Oscillator Plate and Bias Generator Type CAY-21679.....	2-8
D.C. Motor CAY-21678.....	2-8
D.C. Motor CAY-21681.....	2-8
B. Magnetic Controllers.....	2-8
Magnetic Controller Type CAY-211231.....	2-8
Magnetic Controller Type CAY-211232.....	2-8
III. INSTALLATION AND ADJUSTMENT	3-1
A. General	3-1
B. Transmitter Installation.....	3-1
C. Rating and Range.....	3-2
D. Power Supply Line Requirements.....	3-2
E. Motor-Generator and Magnetic Controller Installation.....	3-2
F. Warning	3-2
G. Preliminary Checks, Transmitter.....	3-2
H. Preliminary Checks, Power Equipment.....	3-6
IV. OPERATION	4-1
Warning	4-1
A. Overload Protection.....	4-1
B. Transmitter Unit, Operations.....	4-1
C. Routine Operation, Transmitter.....	4-4
To Stop and Start Equipment.....	4-4
To Change Frequency.....	4-4
To Increase or Decrease Power.....	4-4
D. Motor-Generator and Magnetic Controller Operation.....	4-4
V. MAINTENANCE	5-1
A. General	5-1
B. Transmitter	5-1

Table of Contents—Continued

C. Motor-Generator and Magnetic Controller.....	5-3
D. Lubrication	5-3
E. Maintenance Schedule.....	5-4
F. Troubles and Causes.....	5-4
G. Circuit Checking General.....	5-5
VI. LIST OF ELECTRICAL PARTS.....	6-1
Table I, List of Major Units.....	6-1
Table II, Parts and Spare Parts List by Symbol Designation.....	6-2
Table III, Parts List by Navy Type Numbers.....	6-37
Table IV, Applicable Color Codes and Miscellaneous Data.....	6-41
Table V, List of Manufacturers.....	6-42
VII. ILLUSTRATIONS	7-1
VIII. VACUUM TUBE DATA.....	8-1
A. General	8-1
B. Master Oscillator Tube, Type 860.....	8-3
C. First Intermediate Amplifier Tube, Type 860.....	8-3
D. Second Intermediate Amplifier Tube, Type 860.....	8-4
E. Power Amplifier Tube, Type 861.....	8-4

Index to Illustrations

		Page
<i>Fig. 1</i>	Transmitter Unit Type CAY-52217, 115 V. D.C. Operation, and Type CAY-52218, 230 V. D.C. Operation. Front View (Photo C-5082)	7-1
<i>Fig. 2</i>	Transmitter Unit Type CAY-52217, 115 V. D.C. Operation, and Type CAY-52218, 230 V. D.C. Operation, Front View, Access Doors Open (Photo C-)	7-2
<i>Fig. 3</i>	Transmitter Unit Type CAY-52217, 115 V. D.C. Operation, and Type CAY-52218, 230 V. D.C. Operation, Rear View—Shields Removed (Photo C-)	7-3
<i>Fig. 4</i>	Transmitter Unit, Type CAY-52217, 115 V. D.C. Operation and Type CAY-52218, 230 V. D.C. Operation. Front Left Oblique—Left Side Shields Removed (Photo C-)	7-4
<i>Fig. 5</i>	Transmitter Unit, Type CAY-52217, 115 V. D.C. Operation, and Type CAY-52218, 230 V. D.C. Operation. Rear Left Oblique—Left Side Shields Removed (Photo C-)	7-5
<i>Fig. 6</i>	Transmitter Unit, Type CAY-52217, 115 V. D.C. Operation, and Type CAY-52218, 230 V. D.C. Operation. Front Right Oblique—Right Side Shields Removed. (Photo C-)	7-6
<i>Fig. 7</i>	Transmitter Unit, Type CAY-52217, 115 V. D.C. Operation, and Type CAY-52218, 230 V. D.C. Operation. Rear Right Oblique—Right Side Shields Removed (Photo C-)	7-7
<i>Fig. 8</i>	Master Oscillator Unit, Right Side View. Shields Removed (Photo C-)	7-8
<i>Fig. 9</i>	Master Oscillator Unit, Left Side View. Shields Removed (Photo C-)	7-9
<i>Fig. 10</i>	Motor-Generator Unit, Type CAY-21675, 115 volt, D.C. Operation, Side View Covers Removed (Photo C-)	7-10
<i>Fig. 11</i>	Motor-Generator Unit, Type CAY-21676, 230 volt, D.C. Operation, Side View Covers Removed (Photo C-5085)	7-11
<i>Fig. 12</i>	Magnetic Controller Unit, Type CAY-211231, 115 Volt D.C. Operation, Front View, Door Open (Photo C-)	7-12
<i>Fig. 13</i>	Magnetic Controller Unit, Type CAY-211232, 230 Volt D.C. Operation, Front View, Door Open (Photo C-)	7-13
<i>Fig. 14</i>	Schematic Drawing TBK-20 D.C. Equipments showing all units (Dwg. W-7300718)	7-14
<i>Fig. 15</i>	Wiring Diagram, Transmitter Unit, Type CAY-52217, 115 V. D.C. Operation, and Type CAY-52218, 230 V. D.C. Operation. (Dwg. W-7300446)	7-15
<i>Fig. 16</i>	Outline and Mounting Dimensions, Transmitter Unit, Type CAY-52217, 115 V. D.C. Operation, Type CAY-52218, 230 V. D.C. Operation. (Dwg. T-7611719)	7-16
<i>Fig. 17</i>	Outline and Mounting Dimensions, Motor-Generator Set, Type CAY-21676, 230 Volt D.C. Operation and Motor-Generator Set, Type CAY-21675, 115 Volt D.C. Operation, (Dwg. T-7611738)	7-17
<i>Fig. 18</i>	Outline and Mounting Dimensions—Magnetic Controller Unit, Type CAY-211231, 115 Volt D.C. Operation and Type CAY-211232, 230 Volt D.C. Operation (Dwg. P-7713319)	7-18
<i>Fig. 19</i>	Interconnection Diagram, Model TBK-20 D.C. (Dwg. T-7611742)	7-19
<i>Fig. 20</i>	Tuning Curve for Master Oscillator, Controls A and B. Curve #226373	7-20
<i>Fig. 21</i>	Tuning Curve for Doubler Circuit—Control C. Curve #218634	7-21
<i>Fig. 22</i>	Tuning Curve for First Intermediate Amplifier Control D. Curve #218636	7-22
<i>Fig. 23</i>	Tuning Curve for Second Intermediate Amplifier and Power Amplifier—Controls E and F. Curve #218635	7-23

Index to Illustrations—Continued

<i>Fig. 24</i>	Standard Colpitts Oscillator Circuit and Electron Coupled Oscillator Circuit (Dwg. P-7705422)	7-24
<i>Fig. 25</i>	Keying Relay Contact Adjustment (Dwg. P-7711743)	7-25
<i>Fig. 26</i>	Dimensional Drawings and Winding Data of Tuning Coils and Variometer. (Dwg. T-7607966)	7-26
<i>Fig. 27</i>	Dimensional Drawings and Winding Data of Transformers and Reactors (Dwg. T-7607964 and T-7607965)	7-27
<i>Fig. 28</i>	Transmitter, Contactor and Relay Operating Table	7-28
<i>Fig. 29</i>	Magnetic Controller Contactor and Relay Operating Table	7-29
<i>Fig. 30</i>	Table of Typical Dial and Tap Settings	7-30
<i>Fig. 31</i>	Table of Typical Meter Readings	7-31

List of Plans for Record Drawings

Drawing	Sheet	DESCRIPTION
CAY-T-155	1	INDEX
CAY-T-155	11	Wiring and Assembly Drawing H.V. Generator, Type CAY-21680, a part of Motor Generator Set, Type CAY-21675, CAY-21676, and CAY-21677 (Dwg. 33-J-173)
CAY-T-155	12	Specifications, High Voltage Generator, Type CAY-21680, a part of Motor Generator Set, Type CAY-21675, CAY-21676, and CAY-21677 (Dwg. 33-J-174)
CAY-T-155	13	Wiring and Assembly, Low Voltage Generator, Type CAY-21679, a part of Motor Generator Set, Type CAY-21675, CAY-21676, and CAY-21677 (Dwg. 33-J-175)
CAY-T-155	14	Specifications, Low Voltage Generator, Type CAY-21679, a part of Motor Generator Set, Type CAY-21675, CAY-21676, and CAY-21677 (Dwg. 33-J-176)
CAY-T-155	29	Wiring and Assembly, Motor Type CAY-21681, 230 Volt D.C. Operation, a part of Motor Generator Set, Type CAY-21676 (Dwg. 33-J-177)
CAY-T-155	30	Specifications, Motor Type CAY-21681, 230 Volt D.C. Operation, a part of Motor Generator Set, Type CAY-21676 (Dwg. 33-J-178)
CAY-T-155	31	Wiring and Assembly, Drawing, Motor Type CAY-21678, 115 Volt D.C. Operation, a part of Motor Generator Set, Type CAY-21675 (Dwg. 33-J-179)
CAY-T-155	32	Specifications, Motor Type CAY-21678, 115 Volt D.C. Operation, a part of Motor Generator Set, Type CAY-21675 (Dwg. 33-J-180)
CAY-T-155	33	Outline and Assembly and Specifications, Magnetic Controller, Type CAY-211231, 115 Volt D.C. Operation (Dwg. 45-J-406)
CAY-T-155	34	Outline and Assembly and Specifications, Magnetic Controller, Type CAY-211232, 230 Volt D.C. Operation (Dwg. 45-J-408)

Contractual Guarantee

The equipment including all parts and spare parts, except vacuum tubes, batteries, rubber and material normally consumed in operation, is guaranteed for a period of one year from the date of delivery of the equipment to and acceptance by the Government with the understanding that all such items found to be defective as to material, workmanship or manufacture will be repaired or replaced, f.o.b. any point within the continental limits of the United States designated by the Government, without delay and at no expense to the Government; provided that such guarantee will not obligate the Contractor to make repair or replacement of any such defective items unless the defect appears within the aforementioned period and the Contractor is notified thereof in writing within a reasonable time and the defect is not the result of normal expected shelf life deterioration.

To the extent the equipment, including all parts and spare parts as defined above, is of the Contractor's design or is of a design selected by the Contractor, it is also guaranteed, subject to the foregoing conditions, against defects in design with the understanding that if ten per cent (10%) or more of any such said item, but not less than two of any such item, of the total quantity comprising such item furnished under the contract, are found to be defec-

tive as to design, such item will be conclusively presumed to be of defective design and subject to one hundred per cent (100%) correction or replacement by a suitably redesigned item.

All such defective items will be subject to ultimate return to the Contractor. In view of the fact that normal activities of the Naval Service may result in the use of equipment in such remote portions of the world or under such conditions as to preclude the return of the defective items for repair or replacement without jeopardizing the integrity of Naval communications, the exigencies of the Service, therefore, may necessitate expeditious repair of such items in order to prevent extended interruption of communications. In such cases the return of the defective items for examination by the Contractor prior to repair or replacement will not be mandatory. The report of a responsible authority, including details of the conditions surrounding the failure, will be acceptable as a basis for affecting expeditious adjustment under the provisions of this contractual guarantee.

The above one year period will not include any portion of time the equipment fails to perform satisfactorily due to any such defects, and any items repaired or replaced by the Contractor will be guaranteed anew under this provision.

Instructions to Operating Personnel Regarding Report of Failure

Report of failure of any part of this equipment, during its service life, shall be made to the Bureau of Ships in accordance with current instructions. The report shall cover all details of the failure and give the date of installation of the equipment. For procedure in reporting failure see Chapter 31 (mimeographed form) of the Manual of Engineering Instructions, or Bureau of Ships Radio and Sound Bulletin, Number 7, dated July 1, 1942, or superseding instructions.

The blank spaces indicated below should be filled in by ship or station force immediately upon completion of the initial service installation. The date of acceptance by the Navy can be determined by the stamped acceptance plate located on the front panel, immediately below the type plate. These dates are stamped in the sequence of month, day and year.

Contract NXsr-51573, Dated March 14, 1944
Serial Number of Equipment.....
Date of Acceptance by Navy, (Month)
(Day) (Year)
Date of Delivery to Contract Destination,
(Month) (Day) (Year)

Date of Completion of Installation, (Month).....
(Day)..... (Year).....
Date Placed in Service, (Month).....
(Day)..... (Year).....

All requests or requisitions for replacement material should include complete descriptive data covering the part desired in the following form:

1. Name of part desired.
2. Navy Type Number (if assigned) (including prefix and suffix as applicable).
3. Model designation (including suffix of equipment in which used).
4. Navy Type designation (including prefix and suffix where applicable) of major unit in which part is used.
5. Symbol designation of part.
6. (a) Navy Drawing Number.
(b) Manufacturer's Drawing Number.
7. Rating or other descriptive data.
8. Commercial designation.

RESTRICTED

Navy Model TBK-20 Radio Telegraph and Telephone Transmitting Equipment

I. Introduction

A. General, Transmitter

1-1 The Navy Model TBK-20 Radio Telegraph and Telephone Transmitting Equipment has been designed for installation and operation on all types of Naval vessels with exception of certain types of submarines. It consists of two Transmitter Units, Navy Type CAY-52217 and CAY-52218; two Magnetic Controller Units, Navy Type CAY-211231 and CAY-211232; and two Motor-Generator Sets, Navy Type CAY-21675 and CAY-21676.

1-2 Each of the models is built up around a Transmitter Unit, which is fundamentally the same for all models. The Transmitter Units cover a frequency range of 2,000 to 18,100 kilocycles with a nominal CW telegraph power output of 500 watts. Provisions are made for disconnecting the final power amplifier to permit low power CW telegraph operation with a nominal power output of 75 watts in the frequency range of 2,000 to 9,050 kilocycles. The design of the Transmitter Units is based on the Master Oscillator—Intermediate Amplifiers—Power Amplifier principle. The transmitter frequency as controlled by the Master Oscillator is continuously variable in the specified frequency band.

1-3 The TBK-20 Equipments are supplied with relay keying facilities for keying speeds, up to 100 words per minute on CW transmission.

1-4 The TBK-20 Transmitter may be controlled locally, or, for CW Transmissions, it may be controlled from a remote point by means of a standard Navy Type 23005 4-wire control or a Type 23146 6-wire control. The 4- or 6-wire Remote Control Units are not supplied as a part of the TBK-20 Equipments. Minor circuit changes easily made at the time of installation permit adapting the Equipment for either 4- or 6-wire control.

1-5 The control circuits in the TBK-20 equipments are designed for 115 or 230 V. D.C. operation depending upon the power supply voltage. In the

230 V. D.C. units, resistors are inserted in series with the relay circuits to drop the relay operating voltages to their proper value.

1-6 The filament circuit power for the TBK-20 D.C. equipments is taken from slip rings on the D.C. driving motor.

1-7 The TBK-20 equipment has been designed for use with either one of the following types of power supplies:

- 115 V. D.C. Supply
- 230 V. D.C. Supply

B. Power Equipment

1-8 The power equipment used with TBK-20 units, is designed to convert the available supply line power to suitable D.C. power for operation of the transmitter.

1-9 For convenience, a table of the various power equipments are given below:

	<i>Used as a part of</i>
Motor Generator	
Type CAY-21675—TBK-20—115 volt D.C. Equipment	
Motor Generator	
Type CAY-21676—TBK-20—230 volt D.C. Equipment	
Magnetic Controller	
Type CAY-211231—TBK-20—115 volt D.C. Equipment	
Magnetic Controller	
Type CAY-211232—TBK-20—230 volt D.C. Equipment	

1-10 The motor-generator units supplied as a part of Model TBK-20 Transmitting Equipment are of the three unit, six-bearing type. All three units are mounted on a cast steel bedplate in such a manner that any unit may be removed from the bedplate without necessitating the displacement of any other unit. The units are coupled together with flexible couplings and are fitted with self aligning ball bearings. Each motor-generator unit consists of two D.C. generators and a driving motor. The D.C.

generators are the same for all equipments. The driving motors differ according to the various supply line voltages for which the transmitting equipments are designed.

1-11 The magnetic controller units supplied as a part of Model TBK-20 Transmitting Equipments are of the remote controlled drip proof, protected magnetic contactor type. The magnetic controller units differ according to the various supply line voltages for which the transmitting equipments are designed. All of the contactors, relays, and resistors associated with the controller are assembled on an insulated panel and mounted in a sheet steel box.

1-12 The power required from the supply line for locked key operation is 4.5 Kw. The maximum allowable supply line variation in voltage for the D.C. equipments is $\pm 10\%$.

C. Weights and Dimensions

1-13 A complete equipment for any one type of power supply consists of the following component units:

115 VOLT D.C. SUPPLY

Radio Transmitter Unit, Type CAY-52217

Height — 72"
Width — 32"
Depth — 24"
Weight — 789 lbs.

Motor Generator Unit, Type CAY-21675, consisting of:

D.C. Motor, Type CAY-21678
High Voltage D.C. Generator, Type CAY-21680
Low Voltage D.C. Generator, Type CAY-21679

Height — 20 $\frac{1}{4}$ "
Length — 78 $\frac{19}{16}$ "
Width — 20 $\frac{1}{4}$ "
Weight — 1150 lbs.

Magnetic Controller, Type CAY-211231

Height — 20 $\frac{1}{2}$ "
Width — 15"
Depth — 10 $\frac{3}{8}$ "
Weight — 76 lbs.

Complete Set of Vacuum Tubes consisting of:

Installed	Spares	Types	Weight Net Each
3	3	860	7 $\frac{1}{4}$ oz.
1	1	861	10 $\frac{1}{4}$ oz.
			Total Weight 2 lbs.

Spare Parts consisting of:

Spare Parts Box #1 containing Transmitter Unit Spare Parts.

Height — 15 $\frac{3}{4}$ "
Width — 25 $\frac{3}{8}$ "
Depth — 16 $\frac{3}{4}$ "
Weight — 120 lbs.

Spare Parts Box #2 containing Power Equipment Spare Parts.

Height — 6 $\frac{3}{4}$ "
Width — 26"
Length — 30 $\frac{1}{2}$ "
Weight — 121 lbs.

Spare Parts Box #3 containing armature for Navy Type CAY-21680 Generator.

Height — 8 $\frac{1}{2}$ "
Width — 10"
Length — 30"
Weight — 55 lbs.

Spare Parts Box #4 containing armature for Navy Type CAY-21679 Generator.

Height — 6 $\frac{3}{4}$ "
Width — 8 $\frac{1}{2}$ "
Length — 24 $\frac{1}{2}$ "
Weight — 110 lbs.

Spare Parts Box #5 containing armature for Navy Type CAY-21675 D.C. Motor.

Height — 10 $\frac{1}{4}$ "
Width — 12 $\frac{3}{4}$ "
Length — 32"
Weight — 105 lbs.

Total Weight of Equipment 2528 lbs.

230 VOLT, D.C. SUPPLY

Radio Transmitter Unit, Type CAY-52218

Height — 72"
Width — 32"
Depth — 24"
Weight — 789 lbs.

Motor Generator Unit, Type CAY-21676 consisting of:

D.C. Motor, Type CAY-21681
High Voltage D.C. Generator Type CAY-21680
Low Voltage D.C. Generator Type CAY-21679

Height — 20 $\frac{1}{4}$ "
Length — 78 $\frac{19}{16}$ "
Width — 20 $\frac{1}{4}$ "
Weight — 1150 lbs.

Magnetic Controller, Type CAY-211232

Height — 20 $\frac{1}{2}$ "
Width — 15"
Depth — 10 $\frac{3}{8}$ "
Weight — 76 lbs.

Complete Set of Vacuum Tubes consisting of:

Installed	Spares	Type	Weight Net Each
3	3	860	7 $\frac{1}{4}$ oz.
1	1	861	10 $\frac{1}{4}$ oz.
			Total Weight 2 lbs.

Spare Parts consisting of:

Spare Parts Box #1 containing Transmitter Unit Spare Parts.

Height — 15 $\frac{3}{4}$ "
Width — 25 $\frac{3}{8}$ "
Depth — 16 $\frac{3}{4}$ "
Weight — 120 lbs.

Navy Model TBK-20—Radio Transmitting Equipment

Spare Parts Box #2 containing Power Equipment
Spare Parts.

Height — $6\frac{3}{4}$ "
Width — 26"
Length — $30\frac{1}{2}$ "
Weight — 121 lbs.

Spare Parts Box #3 containing armature for Navy
Type CAY-21680 Generator.

Height — $8\frac{1}{2}$ "
Width — 10"
Length — 30"
Weight — 50 lbs.

Spare Parts Box #4 containing armature for Navy
Type CAY-21679 Generator.

Height — $6\frac{3}{4}$ "
Width — $8\frac{1}{2}$ "
Length — $24\frac{1}{2}$ "
Weight — 110 lbs.

Spare Parts Box #5 containing armature for Navy
Type CAY-21681 D.C. Motor.

Height — $10\frac{1}{4}$ "
Width — $12\frac{3}{4}$ "
Length — 32"
Weight — 105 lbs.

Total Weight of Equipment 2523 lbs.

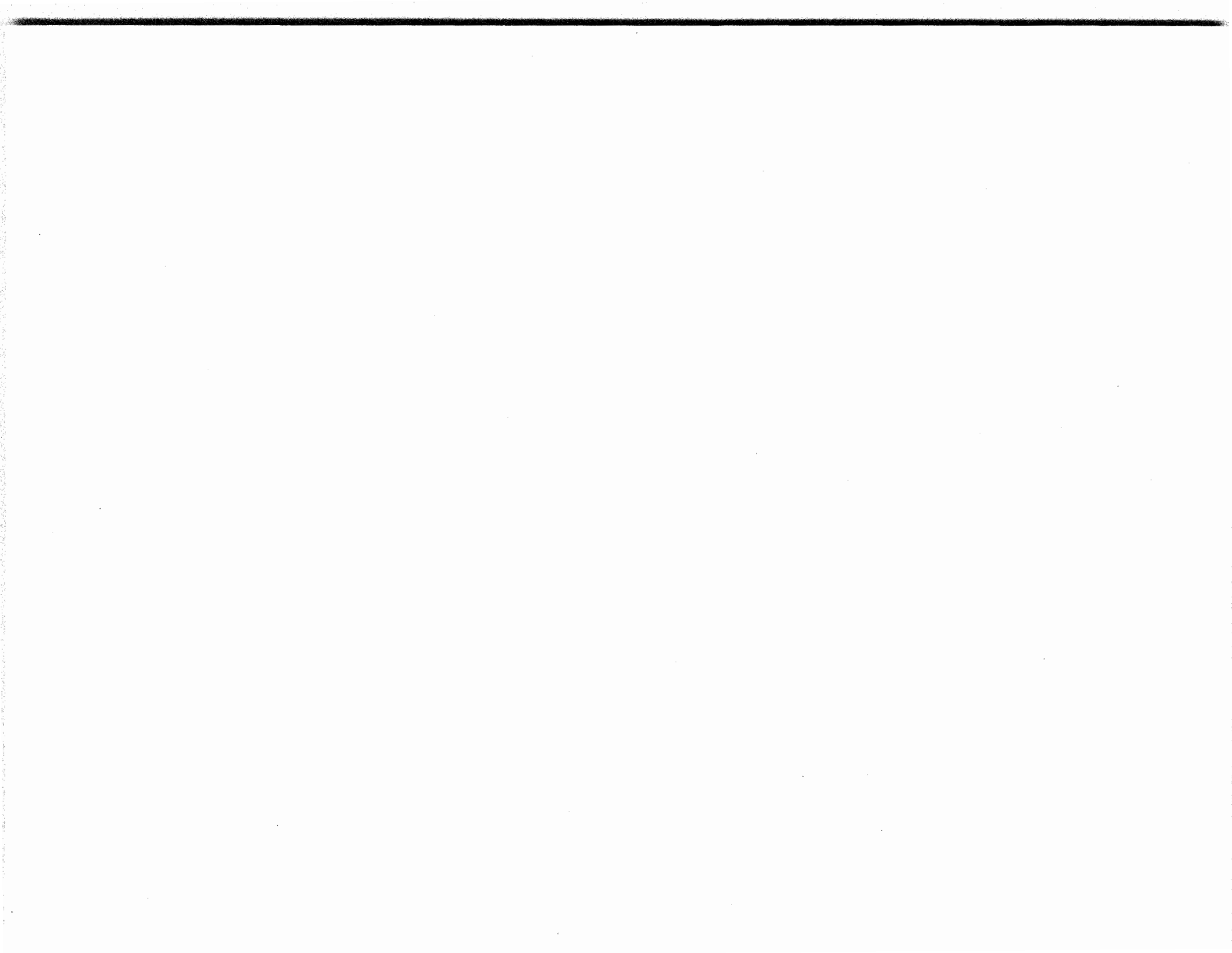

II. Description

TRANSMITTER

A. General

2-1 The difference in power supplies between the TBK-20 equipments, is, for the most part, taken into account by supplying different motors to drive the D.C. Generators and different magnetic controller units. Control circuit power is supplied from 115 or 230 volt D.C. supply. The filament power is supplied from slip rings on the D.C. motor.

2-2 The TBK-20 units utilize either of two different types of Transmitters which are listed below:

Type CAY-52217 a part of Model TBK-20 115 V. D.C. Transmitting Equipment.

Type CAY-52218 a part of Model TBK-20 230 V. D.C. Transmitting Equipment.

2-3 The High Frequency Transmitter Units, Type CAY-52217 and Type CAY-52218 are suitable for use with any antenna that has characteristics which fall within the following limits:

Maximum antenna trunk length.....	35 ft.
Minimum antenna trunk length.....	No trunk
Diameter of trunk, if used.....	8 to 12 in.
Maximum distance of transmitter from inner end of trunk or entering insulator	20 ft.
Minimum distance of transmitter from inner end of trunk or entering insulator	2 ft.
Maximum length of antenna outside trunk	80 ft.
Minimum length of antenna outside trunk, sufficient to permit efficient radiation of energy.	

2-4 The High Frequency Transmitter Units consist of a single frame assembly, including the necessary electrical circuits, tubes and control apparatus for taking power from a suitable motor-generator set and delivering radio frequency energy to an antenna. The nominal CW telegraph radio frequency output is 500 watts in the frequency range of 2000 to 18100 kilocycles. The power output may be varied from full power to a minimum of 25% by

means of a single control located on the transmitter units. Provisions are also made for disconnecting the final power amplifier to permit low power CW telegraph operation with a nominal power output of 75 watts in the frequency range of 2000 to 9050 kilocycles. Relay keying speeds up to 100 words per minute on CW Telegraph Transmissions may be utilized on TBK-20 Models. The design of the transmitter units is based on the master oscillator-intermediate amplifier-power amplifier principle. The transmitter frequency, as controlled by the master oscillator, is continuously variable within the specified frequency band. All necessary operating controls are located on the front panel and are electrically *dead*. Access to tubes, relays and terminal board connections is through three doors in the front panels. These doors are electrically interlocked to remove dangerous voltages when opened.

2-5 Under these conditions, the High Frequency Transmitter Units will deliver the power given in the following table, using a Navy Type 861 tube as the final amplifier.

Freq. Kcs.	Antenna Cap. mmfd.	Antenna Res. Ohms	Power Output Watts CW
2000	*	*	500
3000	*	*	500
3500	*	*	475
4000	*	*	475
4500	*	*	450
6000	*	*	450
7500	*	*	400
9050	*	*	375
12000	*	*	360
16000	*	*	325
18100	*	*	300

*500 Watt, 110 V. Mazda "C" Lamp, practically non-reactive resistance between antenna terminal and ground.

2-6 In the equipment schematic diagrams and the control schematic diagrams of the TBK-20 equipments, when a circuit part is marked with *two or more* circuit symbols, those symbols refer to parts which vary due to different voltage or frequency ratings, but which perform the same function in a circuit. In the following text, reference will be made to all of the circuit symbols designating a circuit part. These references will be made in the order shown in the table listed below. The symbol coding as it appears on the diagrams and in the table below will not be given in the text. A circuit part which bears only one circuit symbol is used in a given model

independently of the power supply rating of the model.

Unit	Reference Order	Part used with Unit Rated at	Sample Symbol
Transmitter Units	1	115 V.D.C.	R-56
	2	230 V.D.C.	R-57
	3	Common to both 115 V. and 230 V.D.C.	R-10
Magnetic Controller Units	1	115 V.D.C.	K-841
	2	230 V.D.C.	K-851
	3	Common to both 115 V. and 230 V.D.C.	F-801

2-7 In order to follow the description for any one Transmitter Unit, refer to the drawings listed below.

	Fig.	Dwg.
Outline and Mounting Dimensions	16	T-7611719
Schematic Diagram	14	W-7300718
Wiring Diagram	15	W-7300446

2-8 The circuits in the Radio Transmitter Unit include a self-excited Master Oscillator, using a Type 860 tube, a First Intermediate Amplifier using a Type 860 tube, a Second Intermediate Amplifier using a Type 860 tube, a Power Amplifier using a Type 861 tube and an Antenna Tuning System arranged for either current or voltage feed to the antenna. Two tube access doors are provided, one for the master oscillator tube and the other for the amplifier tubes. One access door is provided for the terminal board and relays. All these doors are provided with interlocks which will remove all power (except line voltage and master oscillator heater system power) from the Radio Transmitter Unit if any door is opened.

2-9 For descriptive convenience, the complete Radio Transmitter Unit may be divided into the following seven sections:

- B. Terminal Board and Relay Section
- C. Master Oscillator
- D. First Intermediate Amplifier
- E. Second Intermediate Amplifier
- F. Power Amplifier
- G. Antenna Tuning and Coupling Section
- H. Power and Control Switches

Each of these sections will be described in detail.

B. Terminal Board and Relay Section

2-10 The terminal board and relay panel is located at the bottom of the Radio Transmitter Unit and is accessible by opening an access door in the lower front panel. This door is suitably interlocked with the control circuits and held in place by two door

latches. All external control and power wiring, with the exception of the antenna lead, is connected to the terminal board. Antenna connection is made at the top of the unit and is accessible through a hole located in the top shield. For TBK-20 Transmitter Units, Type CAY-52217, and Type CAY-52218, see Outline Drawing Fig. 16 Dwg. T-7611719. Mounted on the terminal board and relay panel for Types CAY-52217 and CAY-52218 (see Fig. 2), are the H.V. Overload Relay K-5, M.O. Plate Overload Relay K-7, Compensator Relay K-2, Starting Contactor, K-4, and Field Contactor K-9 used in the keying control circuits. Behind the terminal board panel are mounted the Filament Transformer T-1 and M.O. Filament Transformer T-12. Also mounted behind the terminal board are the Keying Filter Choke L-16, M.O. Plate and Screen Voltage Filter Capacitor C-47, Grid Bias Filter Capacitor C-48, 2000 Volt Filter Capacitor C-58, H.V. Filter Capacitor C-65, Bias Potentiometer Resistors R-1, R-19, R-21 and R-28, M.O. Screen Grid Resistor R-2, M.O. Plate Resistor R-3, H.V. Potentiometer Resistors R-15, R-16, R-45, R-46, R-47, and R-48.

C. Master Oscillator

2-11 On the left side of the transmitter is the master oscillator, which is mounted within the transmitter as a separate unit. It is 35½ inches high, 22 inches deep, and 12½ inches wide. This complete unit may be removed from the transmitter for servicing. The master oscillator unit is mounted with springs and snubbed by means of sponge rubber cushions in such a manner that very little vibration is transmitted from the transmitter frame to the M.O. unit.

2-12 The master oscillator uses a Type 860 tube in an electron-coupled circuit which has its tank circuit inductance and capacitance mounted in a temperature controlled compartment in the upper part of the master oscillator unit. This compartment requires approximately three hours to come up to temperature, after which it is automatically held at an approximate constant temperature of 60 degrees C. The temperature is controlled by means of mercury-type Thermostat S-13 set for 60 degrees C. and a Thermostat Relay K-20. Thermostat Relay K-20 is operated from Resistor R-56, R-57 which is connected across the 115 or 230 volt D.C. blower motor supply. Temperature protection Switch S-11, in the form of a "Westinghouse Watchman" is connected in series with thermostat relay contacts K-20B and disconnects the heater circuit in case the temper-

ature should rise to 70 degrees C. due to failure of any temperature controlling device. A spark filter, consisting of C-60 and R-49, R-58, is connected across S-11 and thermostat relay contacts K-20B. A spark filter, consisting of R-50, is connected across the contacts of S-13. For Transmitters, Types CAY-52218 and CAY-52217 see Fig. 14, Dwg. W-7300718.

2-13 Blower Motor B-1, located directly above the master oscillator unit, circulates the air constantly within the master oscillator tank circuit compartment. It maintains all frequency determining parts of the circuit at a practically constant temperature. B-1, a 115 volt, D.C. motor, is used in the TBK-20 D.C. Transmitter Units. In the 115 volt D.C. Transmitter Units, Type CAY-52217, B-1 is operated from the 115 volt, D.C. supply voltage. In the above mentioned Transmitter a dummy resistor having zero resistance has replaced Resistor R-7. In the 230 volt D.C. Transmitter Unit, Type CAY-52218, Resistor R-7 is used to drop line voltage to 115 volts for operation of Blower Motor B-1.

2-14 Also located in the constant temperature box is Compensating Capacitor C-62. This capacitor consists of a bi-metallic device which is connected into the circuit in such a manner that it compensates for the effect of variable tube capacity due to tube heating when the Master Oscillator tube is in operation. The bi-metal is actuated by current from Transformer T-3, which is supplied with power through Compensator Relay K-2B contact. *Do Not Make Any Adjustment On Compensating Capacitor C-62. This Capacitor Has Been Set Correctly At The Factory And No Adjustment Is Needed.*

2-15 The cover for the master oscillator heat compartment is fitted with a paper gasket. This has been done to provide good contact at definitely known points only; namely, at the screws; *and to eliminate unknown contact elsewhere.*

2-16 Thermostat Relay K-20 and Thermostat Relay Resistors R-27, R-56, R-57 are located directly above the master oscillator unit.

2-17 The lower right-hand compartment of the master oscillator unit contains the *master oscillator output doubler circuit, which is always tuned to double the master oscillator frequency.*

2-18 The electron-coupled circuit, as used in the master oscillator, is shown complete in the schematic circuit diagrams. Referring to these diagrams, the tuned circuit consists of the variable

tapped master oscillator tank Capacitors, C-1, C-2, C-3 and C-56. This circuit covers the frequency band of 1,000 to 2,262.5 Kcs. Tuning is accomplished by the selection of proper coil taps by MASTER OSCILLATOR RANGE SWITCH S-1 (Control A) and by moving a copper cylinder inside the coil (Control B). In order to avoid neutralizing the master oscillator plate circuit, the screen grid is tied to ground through by-pass Capacitor C-6. The tube filament is operated at a radio frequency potential above ground. The master oscillator Filament Choke L-2 prevents the radio frequency filament potential from leaking off to ground through M.O. Filament Transformer T-12. Capacitors C-8 and C-9 by-pass the filament and provide a mid-tap for connecting the filaments to the tank circuit. Resistor R-2 drops the potential on the screen grid, which is used as an anode in this circuit, to approximately 300 volts. M.O. plate power is supplied to the tube through master oscillator plate Resistor R-3 and the radio frequency master oscillator plate Choke L-4. Resistor R-3 reduces the 1,000 volt plate supply to approximately 700 volts. For this particular application of the Type 860 tube, values of *approximately 300 volts for the screen grid and 700 volts for the plate are the optimum operating voltages* necessary to obtain maximum frequency stability regardless of variations in supply voltage. Choke L-4 prevents the radio frequency plate power from leaking to ground through Resistor R-3 and the 1,000 volt supply. The doubler circuit coupling Capacitor C-13 blocks off D.C. plate potential and also couples the master oscillator to the doubler circuit. This circuit consists of the variable DOUBLER CIRCUIT TUNING Capacitor C-14 (Control C) and the Doubler Tank Coil L-3. It is always tuned to the second harmonic of the oscillator, i.e., tuned to frequencies in the 2000 to 4525 Kcs. band. Therefore, grid excitation is provided for the first intermediate amplifier through Capacitor C-15. A stop has been provided at the high frequency end of the MASTER OSCILLATOR TUNING (Control B), which is effective on the eight ranges of the MASTER OSCILLATOR RANGE SWITCH (Control A), so that proper frequency range and overlap is obtained. This stop is set at such a position that a maximum dial setting of 5000 divisions is obtained. The stop is attached to the threaded shaft on which the copper cylinder in the M.O. Tank Coil L-1 travels. It determines the limit of clockwise rotation of MASTER OSCILLATOR TUNING (Control B).

2-19 The following is a brief explanation of the electron coupled oscillator circuit. In order to more easily explain the circuit, reference is made first to the standard Colpitts oscillator circuit shown in Fig. 24, Dwg. P-7705422. In this circuit, Coil L-1 and Capacitors C-1 and C-2 form the tank circuit, which operates at a frequency "f".

2-20 M.O. tank Capacitors C-1 and C-2 are of such a value as to give the correct voltage distribution to the plate and grid for correct operation. Generally, C-1 is approximately four times as large as C-2. C-3 is the grid blocking capacitor. The grid receives its bias by action of Grid Leak R-1. C-4 is the plate blocking capacitor. The high voltage is fed to the plate through radio frequency Choke RFC-1. The output frequency is the same as that of the tank circuit "f".

2-21 Referring to the electron coupled oscillator circuit shown in Fig. 24, Dwg. P-7705422, it can be seen that the circuit is very similar to the Colpitts circuit using a three element tube. The exception is that the screen grid of the four element tube takes the place of the plate. The tank circuit is again composed of Inductance L-1 and Capacitors C-1 and C-2, and operates at a frequency "f". In order to obtain the shielding action of the screen grid, the screen grid end of the tank circuit is grounded instead of the filament. This operates the filament at radio frequency potential, and necessitates the use of radio frequency Chokes RFC-2 and RFC-3 in the filament leads to Transformer T-1. It should be noted that Capacitors C-1 and C-2 have been interchanged, placing the high radio frequency potential on the grid instead of the screen grid. This causes the output frequency to be high in harmonic content, which is an advantage which will be shown later.

2-22 The plate of the tube is connected through to the output circuit in the same manner as in the Colpitts circuit. The plate, however, does not receive its energy from the oscillator circuit in the usual manner of capacity coupling or direct connection. The grounded screen prevents capacity coupling. Since the electron flow to the plate must pass through the screen grid, the screen modulates the plate current at radio frequency "f". The desired A.C. in the plate circuit is then built up across the impedance offered by Choke RFC-1. This method of coupling is highly advantageous since any change made in the output circuit reflects only very slightly on the tank circuit and does not shift the frequency. This allows a

doubling circuit composed of L-2 and C-7 to be connected to the plate and operated at twice the frequency of the main tank circuit or "2f". This further reduces the effect of any variation in the circuits attached to the output.

2-23 It has been found with the electron coupled circuit that if screen grid voltage is held constant, and plate voltage is varied, the frequency decreases as the plate voltage is increased. Conversely, if plate voltage is held constant, and screen grid voltage is varied, the frequency increases as the voltage is increased. The two curves can be made approximately equal and opposite by proper proportioning of the circuit and operating voltages. Then, if the screen grid and plate are connected to the same potential, and series resistors used to obtain the correct operating voltages, any change in the supply voltage causes only a very small amount of shift in the output frequency. The resistors which accomplish this are R-2 and R-3.

D. First Intermediate Amplifier

2-24 The first intermediate amplifier is located in the lower right-hand compartment of the transmitter. It is used to prevent reaction on the master oscillator by the second, intermediate, and power amplifiers. For transmitter output frequencies of 2000 and 4000 Kcs., the first intermediate amplifier is operated as a fundamental or straight through amplifier at the frequency of the M.O. doubler circuit (L-3, C-14, Control C). For the transmitter output range of 4000 to 9050 Kcs., the first intermediate amplifier (L-7, C-21, Control D) is operated as a frequency multiplier to double the output frequency of the master oscillator doubler circuit (i.e., functioning at four times the frequency of the M.O. tank circuit). When the first intermediate amplifier is operating as a frequency doubler, the FREQUENCY RANGE Switch S-2E (Control L) is closed, shorting out approximately half the turns in Tank Coil L-7. The Type 860 tube, used in this stage, obtains its grid excitation from the tuned output circuits of the master oscillator doubler circuit through Capacitor C-15. Grid Choke L-6 offers a high impedance path for the radio frequency grid voltage to ground. At the same time, it allows a blocking bias to be applied to the tube grid from bias Potentiometer R-19 and R-21. Capacitor C-16 protects the potentiometer and bias circuit from any transient radio frequency potential. Resistor R-25 provides an operating bias in addition to that normally supplied from bias Potentiometers R-19, R-21 and R-28. The

tuned plate circuit consists of the 1ST INTERMEDIATE AMPLIFIER TUNING Capacitor C-21 (Control D) and tank Coil L-7. Filament by-pass Capacitors C-17 and C-18 by-pass the filament and effectively ground it for R.F. Capacitor C-20 grounds one end of the plate tank circuit for R.F. The first intermediate amplifier R.F. Plate Choke L-5 is used to prevent any radio frequency energy from getting back to the plate voltage supply.

2-25 Screen grid potential for this stage is obtained from a potentiometer consisting of Resistors R-15, R-16, R-45, R-46, R-47, and R-48 which are connected across the terminals of the 2000 volt supply. Screen Resistor R-8, in series with the screen, further reduces the screen grid potential by the amount of screen grid current flowing through it. Operation is also improved by providing proper screen grid voltage. The screen grid is effectively grounded for radio frequencies by the first intermediate amplifier screen grounding Capacitor C-19.

E. Second Intermediate Amplifier

2-26 The second intermediate amplifier is located immediately above the first intermediate amplifier. For transmitter output frequencies of 2000 to 9050 Kcs., the amplifier is operated as a fundamental or straight through amplifier. This amplifier may also be used as a final amplifier over the range by operation of HIGH-LOW POWER Switch S-3, S-4 and S-5. This switch disconnects the 500 watt power amplifier tube and transfers the antenna circuit to the second intermediate amplifier. When the second intermediate amplifier is functioning as the final amplifier, an output of approximately 75 watts is obtained. For output frequencies of 9050 to 18100 Kcs., the second intermediate amplifier is operated as a frequency doubler and excites the power amplifier.

2-27 R.F. Grid Choke L-8 offers a high impedance path for the radio frequency grid voltage to ground. At the same time, it allows a blocking bias to be applied to the tube grid from bias Potentiometers R-19, R-21, and R-28. Capacitor C-25 protects the potentiometer and bias circuit from any transient radio frequency potential.

2-28 The tuned plate circuit of the second intermediate amplifier consists of a continuously variable second intermediate amplifier Tank Coil L-9, a variable SECOND INTERMEDIATE AMPLIFIER TUNING Capacitor C-29 (Control E) and a fixed mica second intermediate amplifier tank Capacitor

C-53. The mica capacitor is placed in the circuit by means of FREQUENCY RANGE Switch S-2D for the transmitter output of 2000 to 4000 Kcs.

F. Power Amplifier

2-29 The power amplifier is located in the upper right-hand compartment of the Radio Transmitter Unit and is similar in construction to the second intermediate amplifier except that a Type 861 tube is used. Switches are provided for disconnecting the filament, grid, screen grid, and plate potentials from the tube when the Radio Transmitter Unit is operating on low power (75 watt output). The power amplifier operates as a fundamental or straight through amplifier over the entire frequency range of 2000 to 18100 Kcs. For the frequency range of 2000 to 4000 Kcs., the FREQUENCY RANGE Switch S-2B inserts a fixed P.A. Tank Capacitor C-54 in parallel with POWER AMPLIFIER TUNING Capacitor C-39 in the power amplifier tank circuit. See Switches S-3, S-4 and S-5 on the circuit schematic diagrams. For the Types CAY-52218 and CAY-52217 Transmitters, see Fig. 14, Dwg. W-7300718.

G. Antenna Tuning and Coupling Section

2-30 The antenna tuning circuits and keying Relay K-1 occupy the entire top compartment of the transmitter. The antenna tuning system is made up of Capacitor C-41, antenna tuning Inductance L-13, ANTENNA CURRENT-VOLTAGE FEED SWITCH S-6, ANTENNA TUNING CAPACITOR C-24, and ANTENNA CURRENT Ammeter M-1.

2-31 ANTENNA TUNING CAPACITOR C-42 is variable and is operated in parallel with the variable ANTENNA TUNING INDUCTANCE L-13 for VOLTAGE FEED and in series with L-13 for CURRENT FEED to the antenna. The transmitter antenna terminal is located at the top of the unit and is accessible through a hole in the top shield.

2-32 Keying Relay K-1 is located in this compartment. Contacts K-1C key the master oscillator by opening the ground side of the high voltage plate supply to the Type 860 tube. Contacts K-1C are shunted by keying relay arc suppressor Capacitor C-45 in series with keying relay arc suppressor Resistor R-4. This combination is connected in series with keying filter Choke L-16 to reduce arcing and resultant key clicks to a minimum. The amplifier stages are operated Class C and, therefore, supplied with a bias voltage of sufficient value to block the tubes when no excitation is supplied by the master

oscillator. Contacts K-1D of the keying relay are connected to the terminal board but are not used. Contacts K-1B and K-1E of the keying relay are wired to the terminal board for use in operation of associated receiver attenuator relays. Contact K-1B is a normal "make" contact and may be used for energizing a receiver attenuator relay when the transmitter key is closed. Contact K-1E is a normal "break" contact and may be used to control a receiver attenuator relay which must be de-energized when the transmitter key is closed. When these contacts are used in connection with receiver attenuator relays, suitable spark suppression circuits (capacitor and resistor combination) should be incorporated externally to the transmitter to completely eliminate sparking at the relay contacts for the specific load they are handling.

2-33 The coil of compensator Relay K-2 is energized whenever the coil of Keying Relay K-1 is energized. Closing of the contacts of compensator Relay K-2 controls power to compensating Capacitor C-62. This capacitor maintains frequency stability of the M.O. for key OPEN or CLOSED conditions.

H. Power and Control Switches

2-34 The control switches, and the indicating lamps are located on a panel directly above the master oscillator unit. The control switches are as follows: TEST key S-10, START-STOP Switch S-8 or S-17 (4- or 6-wire control switch), LOCAL-REMOTE Switch S-7, TUNING-STEP 1, STEP 2-OPERATE Switch S-9 and EMERGENCY SWITCH S-12.

2-35 TEST Key S-10 is of the two section toggle type and accomplishes the same function as the remote telegraph key. It will key the Radio Transmitter Unit when it is manually placed in the UP or DOWN position. When this key is placed to the UP position, it automatically locks in position, but when placed to the DOWN position, it will reset to the MID or OFF position as soon as it is released. S-10 is used to excite Keying Relay K-1. For the Types CAY-52218 and CAY-52217 Transmitters, see Fig. 14, Dwg. W-7300718.

2-36 START-STOP Switch S-8 or S-17 is used to start or stop the motor-generator unit supplying power to the transmitter. Two START-STOP Switches (S-8 and S-17) are provided. These two switches allow the use of either a 4- or 6-wire remote control system with the equipment. Switch S-8 is to be used with a 4-wire control system and S-17 with a 6-wire control system. All transmitter

units are wired for 4-wire control at the factory. Minor circuit changes, easily made at the time of installation, permit the use of this equipment with either 4- or 6-wire control. See Paragraph 3-19 for information. In the 4-wire control system, one side of the key circuit and one side of the start-stop switch circuit are common. The type of switch used for starting and stopping the equipment is a double pole single throw toggle switch type (S-8), connected in series with the starting Contactor K-14, K-4 solenoid. With Switch S-8 closed, the equipment will be in operation and will continue to operate until the starting contactor solenoid circuit is broken by opening of S-8. In the 6-wire control system, the starting circuit and the keying circuit are entirely separate and the start-stop circuit is of the momentary pushbutton type more commonly used for control of large electrical equipment. START-STOP Switch S-17, used for this system, consists of two normally open switches, S-17A and S-17B, which control the operation of the equipment over three control wires as follows: In this system, starting Contactor K-4 must operate with Resistor R-35 (in the case of 115 volt D.C. equipments), and R-34 (in the case of 230 volt D.C. equipments) in series with its operating solenoid. The START portion S-17A is connected in series with starting contactor Solenoid K-4A. Momentarily closing Switch S-17A closes Contactor K-4. Contact K-4B immediately interlocks or parallels S-17A so that upon releasing S-17A, the solenoid circuit remains closed and the equipment stays in running condition. To stop the equipment, starting Contactor K-4 solenoid is shorted by the STOP portion S-17B of START-STOP Switch S-17, thereby causing the contactor to open. Contact K-4B immediately breaks the holding circuit of the starting contactor and remains open. The equipment shuts down until the START Switch Button S-17A is again closed. Resistor R-35, R-34 prevents the line from becoming short-circuited when the STOP button S-17B is closed. Link switches S-18, S-19 are provided to permit rapid selection of circuits for either 4- or 6-wire control. Rapid installation of the proper START-STOP Switch S-8 or S-17 is made possible by use of a small terminal block directly below the switch-mounting to which the switch is connected. Properly marked leads are attached to each switch to facilitate easy and correct wiring.

2-37 On all transmitter units, REMOTE-LOCAL Switch S-7 is used to switch the control of the transmitter units to the 4- or 6-wire Remote Control Units and/or the Radiophone Units.

2-38 TUNE-OPERATE Switch S-9 is intended for use as its name implies. It has three positions; the first, labelled TUNING STEP 1, is for use in making the adjustments of the master oscillator. When the switch is in this position, the plate voltage is removed from all of the amplifier stages. In the second or TUNING STEP 2 position, the plate potential is applied to all amplifier stages but at a safe value for tuning. In the third, or OPERATE position, the plate potential is increased to the operating value determined by the position of generator field Rheostat R-33 on the transmitter.

2-39 EMERGENCY SWITCH S-12 is used to shut down the complete equipment in case of an emergency. S-12 opens both sides of the control circuit power supply line, thus de-energizing all relays and shutting down the equipment.

2-40 Indicator lights are provided as follows: Reading from left to right: STARTING SOLENOID I-2 (Red), PLATE VOLTAGE I-3 (Red), HEATER CIRCUIT I-5 (Amber), BIAS VOLTAGE I-1 (Green) and M.O. FILAMENT I-4 (Clear).

2-41 In order to permit rapid adjustment of the master oscillator to any desired frequency within its range, provisions have been incorporated in the Transmitter Units for connection of a standard frequency measuring equipment, such as Model LD. On the left side of the tuning chart is located the FREQUENCY METER AUDIO OUTPUT Jack J-1, making the output from the frequency meter available at the transmitter, adjacent to the frequency determining controls.

POWER EQUIPMENT

A. Motor-Generator

2-42 For the convenience of the reader, a tabulation of the various Motor Generator Types and their component units is given below:

Motor Gen. Type	Driving Motor Type	Rating
CAY-21675	CAY-21678	115 V. D.C.
CAY-21676	CAY-21681	230 V. D.C.
H.V. Gen. Type	L.V. Gen. Type	Rating
CAY-21680	CAY-21679	115 V. D.C.
CAY-21680	CAY-21679	230 V. D.C.

Note: All driving motors are rated at 5 hp and 1800 rpm.

2-43 The motor-generator sets supplied as part of Navy Model TBK-20 Radio Telegraph Transmitting Equipment are of rugged design. These M-G sets have ample capacity for the satisfactory operation of the Radio Transmitter units alone or in combina-

tion with a Modulator Unit Navy Type CAY-50065-A. The machines have the following rating: Main Plate Generator Type CAY-21680, 3000 volts—0.35 Amp. D.C. and 2000 Volts—0.75 Amp. D.C. M.O. Plate and Bias Generator Type CAY-21679, 1000 Volts—0.075 Amp. D.C. and 275 Volts—1.3 Amp. D.C.

Driving Motor—5 H.P.

D.C. motors supply 535 watts A.C. power from slip rings.

2-44 Motors suitable for operation from the various power supplies are described below.

2-45 The motors and generators are semi-enclosed, constant speed, continuous duty, self-ventilating and drip proof from all angles within the limits of 45° on either side of the vertical and included in any plane perpendicular to the axis. The units are rated on the basis of 40°C. temperature rise in an ambient temperature of 50°C.

2-46 The various units of the motor-generator unit are fitted with ball bearings and are flexibly coupled together and mounted on a cast steel bedplate. They are so designed and constructed that the entire motor-generator unit may be moved about or supported at its extreme ends while running without disturbing the alignment of the units. Any unit may be removed without necessitating the removal of any other unit on the bedplate.

2-47 The D.C. generators are excited from the bias generator. Fuses are installed on the terminal boards of all generators to protect them against damage due to the failure of any part of the equipment.

(1) Main Plate Generator Type CAY-21680

2-48 The double commutator 2000 and 3000 volt D.C. plate power generator Type CAY-21680 is compound wound and separately excited from the 275 volt D.C. bias generator Type CAY-21679. It is rated at 2.31 Kw. for 40°C. temperature rise and will deliver .75 amperes at 2000 volts and .35 amperes at 3000 volts. This unit consists of a single core generator with a commutator mounted on each end. There are two main poles and two commutating poles. There are two output windings in the armature slots. A 2000 volt winding connects to the commutator on the motor end of the machine, and a 1000 volt winding connects to the commutator on the blower end of the unit. The output from these two circuits is connected in series so that there is available from the unit both 2000 and 3000 volt outputs. All terminals and fuses are mounted on

ceramic insulators. This unit is used to supply the plate and screen grid power to the intermediate amplifiers, power amplifier, and to the Modulator Unit when it is used. See drawings CAY-T-155 Sheets 11, and 12, Drawings 33-J-173, and 33-J-174.

(2) Master Oscillator Plate and Bias Generator Type CAY-21679.

2-49 The 275 and 1000 volt D.C. generator Type CAY-21679 is compound wound. Its shunt field is excited from the 275 volt winding, and the compound winding is connected in series with the 1000 volt winding. The 1000 volt winding is connected to the commutator at the shaft projection end of the machine. The generator is rated at .43 Kw. continuous load for 40°C. temperature rise and will deliver 1.3 ampere at 275 volts D.C. and .075 ampere at 1000 volts D.C. The unit has a two-pole field and double commutator two winding armature as shown on CAY-T-155, Sheets 13, and 14, Dwgs. 33-J-175, and 33-J-176. The generator is used to supply 275 volts for amplifier tube bias and generator excitation; and plate, screen and bias voltages for the first two audio stages in the Modulator Unit, when used. The 1000 volt winding is used to supply plate and screen grid power for the master oscillator tube. The terminals and fuse of the 1000 volt circuit are mounted on ceramic insulators. A porcelain fuse block is used for the 275 volt circuit.

(3) D.C. Motor Type CAY-21678

2-50 The 115 volt D.C. Motor Type CAY-21678 is of the shunt wound type and is rated at 5 H.P., 1800 rpm. The motor is provided with four main poles and two commutating poles. A pair of slip rings are mounted on the armature shaft opposite the commutator. The armature winding is tapped at two points and connected to the slip rings. A.C. power output of 535 watts, 80 volts, 60 cycle single phase is available from the slip rings for filament heating.

(4) D.C. Motor Type CAY-21681

2-51 The 230 volt D.C. motor Type CAY-21681 is of the shunt wound type and is rated at 5 H.P., 1800 rpm. The motor is provided with four main

poles and two commutating poles. A pair of slip rings are mounted on the armature shaft opposite the commutator. The armature winding is tapped at two points and connected to the slip rings. A.C. power output of 535 watts, 160 volts, 60 cycle, single phase is available from the slip rings for filament heating.

B. Magnetic Controllers

2-52 The magnetic controllers supplied as part of the Navy Model TBK-20 Transmitting Equipment are of the remote controlled, drip-proof, protected magnetic contactor type. All of the contactors, relays and resistors, associated with the controller are assembled on an insulated panel and mounted in a sheet steel box.

(1) Magnetic Controller Type CAY-211231

2-53 The magnetic controller Navy Type CAY-211231, 115 Volt D.C. is rated 5 H.P. and is of the Class A shockproof type. The complete controller consists of a line contactor, a thermal overload relay, two time delay accelerating contactors, one control circuit fuse, one control circuit resistor, and one starting resistor all mounted on an insulating panel. This panel is mounted in a hinged, sheet steel box. See Fig. 18 and CAY-T-155, Dwgs. P-7713319 and 45-J-406 for overall and outline dimensions and schematic and wiring diagrams.

(2) Magnetic Controller Type CAY-211232

2-54 The magnetic controller Navy Type CAY-211232, 230 volt, D.C. is rated at 5 H.P. and is of the Class A shockproof type. The complete controller consists of a line contactor, a thermal overload relay, two time delay accelerating contactors, one control circuit fuse, one control circuit resistor and one starting resistor all mounted on an insulating panel. This panel is mounted in a hinged, sheet steel box. See Fig. 18 and CAY-T-155, Drawings P-7713319 and 45-J-408, for overall and outline dimensions and schematic and wiring diagrams.

III. Installation and Adjustment

A. General

3-1 The installation force should become generally familiar with the Description, Installation, and Operation Sections of this book prior to proceeding with the installation. When installing the Transmitter Unit, reference should be made to the interconnection drawings showing the interconnection wiring and recommended wire sizes and types of interconnecting directions.

3-2 In the unpacking and handling of the units during process of installation, care should be exercised to prevent damage to equipment. The following precautions should be observed.

1. Keep boxes and crates containing equipment in an upright position at all times. The upright position is indicated by an arrow pointing upward, stenciled on each box or crate.
2. Observe weights marked on boxes, crates and units, as the larger unit weighs from 1000 to 1500 pounds when packed. Adequate transporting and lifting gear and sufficient handling personnel should be available to prevent equipment from being subjected to unwarranted shock.
3. Remove at least three sides from boxes or crates by removing nails with a nail-puller; do not use a hammer or pinch bar for this purpose.

3-3 The various units should be carefully uncrated and all wrappings removed. The shields should be removed and each compartment given a thorough inspection to determine any damage caused by shipment.

3-4 The Test Data and Instruction Book secured inside the front cover of the Radio Transmitter Unit packing box, after acceptance by the Inspector, should be removed and the Test Data placed in the copy of the Instruction Book for use during installation.

3-5 Any components or wiring which may have been displaced during shipment should be replaced in their proper locations. The shock absorbers on the tube shelves should be inspected to see that they permit normal motion and are not cracked or unduly distorted.

3-6 The interconnection wiring diagram for any of the two voltages is Fig. 19, Dwg. T-7611742.

3-7 The diagram covering the proper equipment should be studied and followed carefully. These diagrams show the type, size and insulation of wire and cable recommended for interconnecting the different units of any one equipment. Complete instructions for the proper connections of motors, transformers, and link switches are contained on the interconnection diagrams for the various equipments.

3-8 After completing the installation of any one equipment, according to the installation description for the various units, and before connecting to the supply line, carefully check all interconnection wiring performed by the installation force. This check should be performed by approved circuit check test practices to insure that all circuits are complete, according to the proper interconnection wiring diagram.

3-9 After thoroughly checking all interconnection wiring, as to proper connection, wire size, and insulation, the preliminary tests of the various units may be carried out.

B. Transmitter Installation

3-10 The Radio Transmitter Units should be installed so that all sides are accessible. Provide for sufficient clearance, preferably not less than 18 inches on the left or master oscillator side so that the master oscillator unit can be removed after installation without making it necessary to unbolt the Radio Transmitter Unit from its foundation. Before the Radio Transmitter is secured in place, all of the wood blocking should be removed from around the master oscillator unit. The holding-down bolt should be completely removed from the bottom of the unit so that the unit hangs free on its supporting springs. After this is done, the shields should be replaced and the Radio Transmitting Unit securely fastened to the foundation by means of one-half inch studs or bolts, through the holes provided in the mounting channels. For Transmitter Units, Types CAY-52217 and CAY-52218, see Outline Dwg. Fig. 16, Dwg. T-7611719. This drawing shows the location of mounting holes.

3-11 The antenna lead should be made up of $\frac{3}{8}$ or $\frac{1}{2}$ inch O.D. copper tubing and should be kept at least six inches away from any grounded objects.

3-12 The frames of the Radio Transmitter Unit, Motor-Generator Unit and Magnetic Controller should be electrically tied together and grounded by a copper strap at least 1 inch wide and 1/32 inch thick, making certain that a metal-to-metal contact is made at each point of contact.

C. Rating and Range

3-13 Under these conditions, the Radio Transmitter Unit will deliver the power given in the following table, using a Type 861 tube in the final amplifier.

FREQUENCY (KCS.)	OUTPUT WATTS
2000 to 3035 Inclusive	500
3035 to 4105 "	475
4105 to 6000 "	450
6000 to 7500 "	400
7500 to 9050 "	375
9050 to 12000 "	360
12000 to 16000 "	325
16000 to 18100 "	300

A 500 watt, 110 Volt Mazda "C" Lamp, practically non-reactive resistance between antenna terminal and ground, may be used to check power output at all frequencies.

D. Power Supply Line Requirements

3-14	115 D.C.	230 D.C.
Max. Power for Starting (KW)	8.7	8.7
Power for Locked Key (KW)	3.9	3.9
Voltage Variation Permitted	±10%	±10%
Supply Frequency Variation Permitted	—	—

(Power required for starting measured by critically damped instrument)

E. Motor-Generator and Magnetic Controller Installation

3-15 The motor-generator units used with the equipments should be securely bolted to the floor in a place as free as practical from dust and moisture. Overall and mounting dimensions of the motor-generator units are shown on Fig. 17, Dwg. T-7611738.

3-16 The magnetic controller units should be securely bolted in place near the motor-generator units. Fig. 18, Dwg. P-7713319 shows the overall and mounting dimensions of the magnetic controller units used with the various equipments. The

overload relay should be adjusted to operate at a current value indicated in the following table.

3-17 Normal Magnetic Controller Overload Relay Setting.

Controller Rating	Overload Relay Setting Amperes
230 Volt D.C.	32 Amp.
115 Volt D.C.	64 Amp.

F. Warning

3-18 *Warning! Operation of this equipment involves the use of high voltages which are dangerous to life. Operating personnel must at all times observe all safety regulations. (See page v.) Do not change tubes or make adjustments inside equipment with high voltage supply on. Do not depend upon door switches or interlocks for protection but always shut down the motor-generator, or other power equipment, and open the main line switch in supply line to equipment. Interlocks are provided on normal access doors only. Always ground internal units or circuits before touching them. Under certain conditions, dangerous potentials may exist on circuits after shut-down due to charges retained by capacitors. Always discharge the filter capacitors as some may be holding dangerous charges, even though the power may not be on the set. There are bleeder resistors or other circuits across the power filter capacitor, but the additional precaution of grounding the filter capacitors is essential in case the capacitors have not completely discharged. When shutting down the equipment, never reach inside any unit until the motor-generator set has stopped revolving, as dangerous potentials are generated at all speeds. All necessary precautions should be observed to prevent injury to personnel.*

G. Preliminary Checks, Transmitter

3-19 All link switches must be in their proper position before power is applied to the equipment. Make sure that the proper resistors are in place in accordance with the schematic diagrams. For four or six wire control, make connections as shown on the interconnection diagram.

3-20 Refer to Figure 1, showing the location of the controls, and with no tubes in the Radio Transmitter Unit, place the controls of Radio Transmitter Unit as follows:

3-21 Turn the filament Rheostat R-6 and field Rheostat R-33 counterclockwise to maximum resistance position.

- 3-22 HIGH-LOW POWER Switch S-3 to the HIGH position.
- 3-23 LOCAL-REMOTE Switch S-7 to LOCAL.
- 3-24 TUNE-OPERATE Switch S-9 to TUNING STEP 1.
- 3-25 START-STOP Switch S-8, S-17 to STOP.
- 3-26 EMERGENCY SWITCH S-12 to ON.
- 3-27 TEST Key S-10 to neutral position.
- 3-28 Close all access doors to Radio Transmitter Unit.
- 3-29 M. O. FILAMENT STAND-BY Switch S-27 to ON. (A.C. equipment only.)
- 3-30 Push in OVERLOAD RELAY RESET Button.
- 3-31 Power is supplied to the transmitter used as a part of the Model TBK-20 equipment whenever power is applied to the line terminals of the magnetic controller. This power is used for operation of the master oscillator heater system, and the transmitter unit control circuits. This power is always available at the transmitter regardless of whether or not the motor-generator is in operation.
- 3-32 As soon as power is applied to the transmitter the following operation should take place in the Radio Transmitter Unit:
- (a) The Blower Motor B-1 should run.
 - (b) The HEATER CIRCUIT Indicator Lamp I-5 (Amber) should light.
- 3-33 Apply filament and plate power (1500 volts) by placing the START-STOP Switch S-8, S-17 on the Radio Transmitter Unit to START.
- (a) Starting Contactor K-4 should close.
 - (b) STARTING SOLENOID Indicator Lamp I-2, I-6 (Red) should light.
 - (c) Motor-generator should start and come up to normal speed in approximately 5 to 10 seconds.
 - (d) FILAMENT VOLTAGE Voltmeter M-11 in the Radio Transmitter Unit should indicate approximately 12 volts.
 - (e) M.O. FILAMENT Indicator Lamp I-4 (Clear) should light.
 - (f) Field Contactor K-9 should close.
 - (g) BIAS VOLTAGE Indicator Lamp I-1 (green) should light and BIAS VOLTAGE Voltmeter M-12 should indicate approximately 275 volts.
- (h) PLATE VOLTAGE Voltmeter M-9 will not indicate but plate voltage (1000 volts) will be applied to the master oscillator plate and screen grid terminals.
- (i) PLATE VOLTAGE Indicator Lamp I-3 (Red) should light.
- 3-34 Test out the door interlocks by opening one door at a time. The motor-generator and Radio Transmitter Units should shut down (except master oscillator heater and blower motor in the transmitter) when any access door is open, and start again when the access door is closed.
- 3-35 Place EMERGENCY SWITCH S-12 to STOP. The motor-generator unit should shut down but power remains on the blower motor and master oscillator heater. On 4-wire control systems, the motor-generator unit should start when EMERGENCY SWITCH S-12 on the Radio Transmitter Unit is placed in the ON position. On 6-wire control systems, it will be necessary, after closing the EMERGENCY SWITCH, to close START-STOP Switch S-17A before the motor-generator will start.
- 3-36 Apply reduced plate voltage (1000 volts) on the intermediate and power amplifiers by placing TUNE-OPERATE Switch S-9 to TUNING STEP 2. PLATE VOLTAGE Voltmeter M-9 should indicate voltage of the 2000 volt armature, which should be about 1000 volts because Field Rheostat R-33 is in the minimum voltage position.
- 3-37 Apply increased plate voltage (1500 volts) on intermediate and power amplifiers by placing TUNE-OPERATE Switch S-9 to OPERATE. PLATE VOLTAGE Voltmeter M-9 should indicate the voltage of the 3000 volt terminal, which is about 1500 volts, as the Field Rheostat is still in minimum voltage position.
- 3-38 Operate TEST Key S-10 on Radio Transmitter Unit.
- (a) Keying Relay K-1 should operate.
 - (b) Compensator Relay K-2 should close.
- 3-39 Shut down the motor-generator and transmitter by placing the START-STOP Switch S-8, S-17 to STOP.
- 3-40 Return TUNE-OPERATE Switch S-9 to TUNING STEP 1.

3-41 Leave LOCAL-REMOTE Switch S-7 in the LOCAL position.

3-42 Place a Type 860 tube in the tube sockets of the master oscillator unit, first and second intermediate amplifiers, and a Type 861 tube in the tube mounting of power amplifier. Make all tube connections, being certain to connect the auxiliary screen grid terminal for the power amplifier tube. This connection is located to the rear of the Type 861 power amplifier tube.

3-43 Apply filament and plate voltage (1500 volts) to the equipment by placing START-STOP Switch S-8, S-17 to START. Adjust the FILAMENT VOLTAGE of the transmitter vacuum tubes to 10 volts as indicated by FILAMENT VOLTAGE Voltmeter M-11 and controlled by FILAMENT VOLTAGE Rheostat R-6. The FILAMENT VOLTAGE Voltmeter M-11 is connected across the filaments of the first and second intermediate amplifier Type 860 tubes instead of across the filaments of the Type 861 tube. The reason being that in the LOW POWER position, the Type 861 tube is not used as the Power Amplifier and is, therefore, disconnected. When the filament voltage Voltmeter M-11 indicates 10 volts, the correct potential is applied to all tubes; 10 volts to the Type 860 and 11 volts to Type 861. Shut down the motor-generator unit and Radio Transmitter Unit by placing START-STOP Switch S-8, S-17 to STOP.

3-44 In conducting the following preliminary installation tests, have at hand one copy each of Routine Test Data, or Type Test Data, that bears the same serial number as the Radio Transmitter Unit and is packed inside the Transmitter Unit after inspection by the Navy Inspector. This Test Data contains the exact dial and control settings for various frequencies between 2000 and 18100 Kcs. taken on this particular Transmitter Unit during Navy Acceptance Test at the manufacturer's plant. Although in service the frequencies desired will not be the same as those shown on Test Data. The approximate dial and control settings can be obtained by interpolation. By carefully following this Test Data, it will be possible to select the correct harmonic of each tuned circuit and avoid the possibility of tuning to a harmonic of a previous stage when the fundamental was desired or vice versa. Approximate calibration curves are given in Figures 20, 21, 22 and 23, Curves Nos. 226373, 218634, 218636 and 218635. A table of Typical Dial and Tap Settings and a table of Typical Meter Readings are given on Figures 30 and 31. For

a preliminary test, the following settings will be approximately correct for a frequency of 2000 Kcs. The various tuning controls are identified by letters as marked on the panel, followed by symbol designations used on the schematic diagram. See Fig. 14, Dwg. W-7300718.

3-45 Close all access doors of the equipment.

3-46 Set Radio Transmitter Unit controls as follows:
(a) Set START-STOP Switch S-8, S-17 to STOP.

(b) Set LOCAL-REMOTE Switch S-7 to LOCAL.

(c) Set TUNE-OPERATE Switch S-9 to TUNING STEP 1.

(d) Set EMERGENCY SWITCH S-12 to ON.

(e) Set the MASTER OSCILLATOR RANGE Switch (Control A) S-1 on Tap 1.

(f) Set MASTER OSCILLATOR TUNING (Control B) L-1 to 1872 divisions.

(g) Set DOUBLER CIRCUIT TUNING (Control C) C-14 to 18 divisions.

(h) Set FIRST INTERMEDIATE AMPLIFIER TUNING (Control D) C-21 to 26 divisions.

(i) Set SECOND INTERMEDIATE AMPLIFIER TUNING (Control E) L-9 to .053 divisions.

(j) Set POWER AMPLIFIER TUNING (Control F) L-14 to .059 divisions.

(k) Set FREQUENCY RANGE SWITCH (Control L) S-2 for the 2000 to 4000 kilocycle range.

(l) Set ANTENNA COUPLING (Control H) C-41 to 1500 divisions.

3-47 Start up the motor-generator unit and transmitter, applying plate voltage of 1500 volts by placing the START-STOP Switch S-8, S-17 to START. Perform the following adjustments on the Radio Transmitter Unit.

3-48 Check FILAMENT VOLTAGE Voltmeter M-11 and adjust, if necessary, to 10 volts by means of FILAMENT VOLTAGE Rheostat R-6.

3-49 Operate TEST Key S-10. The M.O. PLATE CURRENT Meter M-7 and M.O. SCREEN GRID CURRENT METER M-8 should indicate current of about 60 and 11 ma., respectively.

3-50 Set TUNE-OPERATE Switch S-9 to TUNING STEP 2 and adjust Field Rheostat R-33 until PLATE VOLTAGE Voltmeter M-9 indicates 2000 volts.

3-51 Operate TEST Key S-10 and adjust DOUBLER CIRCUIT TUNING (Control C) C-14 for maximum indication on 1ST. INT. AMP. PLATE CURRENT Meter M-6. (Approximately 60 ma.)

3-52 Adjust 1ST INTERMEDIATE AMPLIFIER TUNING (Control D) C-21 for minimum indication on 1ST INT. AMP. PLATE CURRENT Meter M-6 or maximum indication on 2ND INT. AMP. GRID CURRENT Meter M-5. (Approximately 25 ma. on M-6 or 25 ma. on M-5.)

3-53 Adjust 2ND INTERMEDIATE AMPLIFIER TUNING (Control E) L-9 for minimum indication on 2ND INT. AMP. PLATE CURRENT Meter M-4 or for maximum indication on P.A. GRID CURRENT Meter M-3. (Approximately 50 ma. on M-4 or 60 ma. on M-3.)

3-54 Adjust POWER AMPLIFIER TUNING (Control F) L-14 for minimum indication on P.A. PLATE CURRENT Meter M-2.

3-55 If the antenna is under 50 feet long, or over 80 feet long, set ANTENNA FEED Switch S-6 to CURRENT FEED. If between 50 and 80 feet in length, set the ANTENNA FEED Switch S-6 to VOLTAGE FEED. (The dimensions are only approximate.)

3-56 If ANTENNA FEED Switch S-6 is in CURRENT FEED position, set ANTENNA TUNING INDUCTANCE (Control K) L-13 to 0 and adjust ANTENNA TUNING CAPACITOR (Control J) C-42 for maximum output as indicated on ANTENNA CURRENT Meter M-1.

3-57 If ANTENNA FEED Switch S-6 is in VOLTAGE FEED position, set ANTENNA TUNING INDUCTANCE (Control K) L-13 to 1000 divisions and adjust ANTENNA TUNING CAPACITOR (Control J) C-42 for maximum indication on P.A. PLATE CURRENT Meter M-2.

3-58 If P.A. PLATE CURRENT Meter M-2 indicates over 150 milliamperes, reduce ANTENNA COUPLING (Control H) C-41.

3-59 Set TUNE-OPERATE Switch S-9 to OPERATE and adjust Field Rheostat R-33 until PLATE VOLTAGE Voltmeter M-9 indicates 3000 volts. Close TEST Key S-10 and readjust ANTENNA TUNING CAPACITOR (Control J) C-42 for maximum output on ANTENNA CURRENT

Meter M-1. At the same time adjust ANTENNA COUPLING (Control H) C-41, if necessary, to keep P.A. PLATE CURRENT Meter M-2 to a value *not in excess* of 350 milliamperes. It may also be necessary to slightly readjust the POWER AMPLIFIER TUNING (Control F) L-14 for minimum value on P.A. PLATE CURRENT Meter M-2 due to antenna effects. Optimum efficiency of operation is the condition giving maximum indication on the ANTENNA CURRENT Meter M-1 with the minimum indication on P.A. PLATE CURRENT Meter M-2. Refer to Fig. 31 or Test Data which accompanies unit for typical meter readings which were taken with the TUNE-OPERATE Switch S-9 on OPERATE.

3-60 NOTE: In order to resonate the antenna, it may be necessary to try various combinations of ANTENNA TUNING INDUCTANCE (Control K) L-13 and Capacitor (Control J) C-42, also VOLTAGE or CURRENT FEED to the antenna to obtain maximum output without the power amplifier being overloaded.

3-61 When operating the transmitter on lower power, with the HIGH-LOW POWER Switch S-4, S-5 in LOW POWER position, the unit should be tuned as described. However, the following exceptions apply: The POWER AMPLIFIER TUNING (Control F) L-14 and the P.A. GRID CURRENT Meter M-3 is omitted. The ANTENNA COUPLING (Control H) C-41 is so adjusted that the second intermediate amplifier (now used as a final amplifier) 2ND INT. AMP. PLATE CURRENT Meter M-4 *does not exceed* 150 milliamperes. It is to be recalled that the upper limiting frequency is 9050 Kcs. in the LOW POWER position.

3-62 The PLATE VOLTAGE Voltmeter M-9 should not exceed 3000 volts regardless of the position of the HIGH-LOW POWER Switch. This can be adjusted by generator field Rheostat R-33. The 2000 volt circuit of the main generator is used to supply plate and screen grid voltage (2100 volts maximum) to the Type 860 tubes in the first and second intermediate Amplifier stages. This voltage is indicated on PLATE VOLTAGE Voltmeter M-9 when the TUNE-OPERATE Switch S-9 is on Step 2. The PLATE VOLTAGE Voltmeter M-9 always indicates the voltage which would be applied to the plate of the Type 861 tube if the HIGH-LOW POWER Switch S-5 was on HIGH POWER.

3-63 When adjusted to the frequency of 2000 Kcs. normal output, record setting of all frequency determining controls. Shut down the equipment by placing START-STOP Switch S-8, S-17 to STOP.

H. Preliminary Checks, Power Equipment

3-64 After completing the installation of the motor-generator unit and the magnetic controller unit, carefully check all interconnection wiring performed by the installation force. This check should be performed by approved circuit test practices to insure that all circuits are complete according to the interconnection wiring diagram.

3-65 Test on the power equipment must be conducted in conjunction with the tests of the transmitter unit, since the starting and stopping of the motor-generator sets is performed by circuits in the transmitter unit. Refer to paragraphs 3-20 through 3-37.

3-66 Do not reach inside the transmitter while the motor-generator set is revolving, as dangerous potentials are generated at all motor-generator speeds. Be sure to ground all circuits before touching them. Dangerous potentials may be present due to charges retained by the filter capacitor in the transmitter unit.

IV. Operation

4-1 *Warning! Operation of this equipment involves the use of high voltages which are dangerous to life. Operating personnel must at all times observe all safety regulations. See page v. Do not change tubes or make adjustments inside equipment with high voltage supply on. Do not depend upon door switches or interlocks for protection but always shut down the motor-generators or other power equipment and open main switch in supply line to equipment. Interlocks are provided on normal access doors only. Always ground internal units or circuits before touching them. Under certain conditions dangerous potentials may exist on circuits after shut-down due to charges retained by capacitors. Always discharge the filter capacitors as they may be holding dangerous charges, even though the power may not be on the set. There are bleeder resistors or other circuits across the power filter capacitors, but the additional precaution of grounding the filter capacitors is essential in case the capacitors have not completely discharged. When shutting down the equipment, never reach inside any unit until the motor-generator set has stopped revolving, as dangerous potentials are generated at all speeds. All necessary precautions should be observed to prevent injury to personnel.*

A. Overload Protection

4-2 The following overload protection is provided in the Radio Transmitter Unit.

4-3 The coils of H.V. overload Relay K-5 and M.O. plate overload Relay K-7 are located in the transmitter main plate, and master oscillator plate circuit respectively. Relay K-5 and Relay K-7 operate on overload to shut down the motor-generator set and the Radio Transmitter Unit by dropping out main starting Contactor K-4 and field Contactor K-9. These relays are manually reset from the front of the Radio Transmitter Unit panel.

4-4 On Transmitter Units, Types CAY-52217, and CAY-52218, heater circuit Fuse F-1 (6 amp. 250 volts), located on the Radio Transmitter Unit terminal board, protects the master oscillator temperature system including Heater Resistor R-26 and D.C. Blower Motor B-1. Control circuit Fuse F-2 (6 amp. 250 volts) located on the Radio Transmitter Unit terminal board protects the D.C. control circuits.

4-5 Fuses mounted on the generator terminal boards protect the generator high voltage windings against faults in the high voltage cable between the generators and the Radio Transmitter Unit. See paragraphs 2-48 and 2-49.

4-6 Control fuses in the D.C. controller units protect the controller control circuits. See paragraph 2-52.

4-7 In the controller, a thermal overload protective device protects the motor against overload. This relay is of the hand reset type. See paragraphs 2-52 through 2-53.

4-8 Refer to Fig. 25 for pertinent information on adjustment of protective relays.

B. Transmitter Unit Operations

4-9 The Radio Transmitter Unit may be started and stopped by means of START-STOP Switch S-8, S-17 on the Radio Transmitter Unit. When LOCAL-REMOTE Switch S-7 is placed in the REMOTE position, the Transmitter Unit may be started by pressing the remote starting switch on the 4- or 6-wire remote control unit. LOCAL control is always supervisory, in that START-STOP Switch S-8, S-17 on the Transmitter Unit will stop the equipment even when the remote starting switch has been closed.

4-10 In order to obtain the best performance regarding frequency stability and accuracy of calibration, the master oscillator heat compartment, in which are located the frequency determining elements, should be up to approximately 60°C (140°F.) temperature for normal operation. This will require approximately three hours after power has been applied. For this reason, the master oscillator heater circuit should be left ON at all times when operation of the Radio Transmitter Unit is planned within three hours.

4-11 An indicating Thermometer Th-1 (Type CHB-40025) is provided having its bulb in the constant temperature compartment and its scale on the front panel of the transmitter. Under normal ambient temperature conditions of approximately 25°C., Thermometer Th-1 should indicate a temperature between 59° and 61°C. provided that heater circuit power has been on the transmitter for

at least three hours. A slight fluctuation of the thermometer reading of approximately plus or minus .1°C. may be noted, and is due to the cycling of the temperature control apparatus. Because the thermometer bulb is not in intimate contact with the frequency determining circuit parts and also because the thermometer is somewhat affected by the ambient temperature due to exposure of stem and scale, the thermometer reading is not generally an exact indication of the temperature of the circuit parts. If, however, the thermometer reading is between 58.5° and 61.5°C., it may be assumed that the frequency determining circuit parts are at their normal temperature as controlled by Thermostat S-13.

4-12 When LOCAL-REMOTE Switch S-7 in the Transmitter is placed in LOCAL position, Keying Relay K-1 and associate parts K-2, R-17, R-30 receive power for operation from the bias supply in the transmitter. A tap is taken from bias Potentiometers R-19, R-21 and R-28 at such a point that 115 volts D.C. appears between this tap and ground when the key is closed and the Transmitter is operated so as to give rated output. The actual circuit is from the bias potentiometer through keying relay series Resistor R-30 to terminal 19 on the terminal board. From terminal 19, the circuit passes through range switch Interlocks S-2A, S-9B and S-1C to terminal 20 on the terminal board. From terminal 20, the circuit goes to Relays K-1 and K-2 in parallel and then through TEST Key S-10 to ground which completes the circuit. The circuit is wired to terminals 19 and 20 on the terminal board to provide a means for circuit checking in case trouble arises in the keying circuit and if necessary, to short circuit Switch Interlocks S-2A, S-9B, S-1C in an emergency.

4-13 In the 115 volt D.C. Transmitter Unit, Type CAY-52217, it is also possible, by means of link Switch S-20, to connect the keying relay circuits across the 115 volt D.C. Supply line. See Fig. 14, Dwg. W-7300718.

4-14 In the 230 volt D.C. Transmitter Unit, Type CAY-52218, it is possible by means of link Switch S-20 to connect the keying relay circuits across a potentiometer consisting of R-36 and R-29, which is connected across the 230 volt D.C. Supply Line. See Fig. 14, Dwg. W-7300718.

4-15 After the motor-generator, magnetic controller, and Radio Transmitter Unit have been installed and preliminary tests completed, the calibration and further check on the operation of equipment should be effected as follows:

4-16 Close access doors of the Radio Transmitter Unit and Magnetic Controller.

4-17 Set Radio Transmitter Unit Controls as follows:
(a) Set START-STOP Switch S-8, S-17 to STOP.

(b) Set LOCAL-REMOTE Switch S-7 to LOCAL.

(c) Set TUNE-OPERATE Switch S-9 to TUNING STEP 1.

(d) Set EMERGENCY SWITCH S-12 to ON.

(e) Refer to the Table of Typical Dial and Tap Settings Fig. 30 and Test Data which accompanies this equipment and set Tuning Controls "A", "B", "C", "D", "E", "F", "G", "H", "J", "K", and "L" to the approximate frequency desired.

(f) The frequency standard that is to be used to calibrate the transmitter should be started and set to desired frequency. This frequency standard can be any type of heterodyne frequency meter used in the Service that is capable of giving beats on the fundamental frequencies of 2000 to 4525 Kcs. Due to the frequency stability of the transmitter, it is only necessary to set the master oscillator to the desired frequency by the frequency standard. Then, adjust the intermediate amplifiers, power amplifier and antenna tuning circuits to resonance. The audio output from the frequency standard is available at the FREQUENCY METER AUDIO OUTPUT Jack, J-1, which will facilitate calibration.

(g) R.F. coupling terminals are provided on the transmitting unit for connection to the frequency standard. Approximately 15 millivolts of R.F. is available at these terminals, at the Master Oscillator output frequency providing the DOUBLER CIRCUIT TUNING (Control C.) is tuned.

4-18 The R.F. voltage is provided by coupling Capacitor C-68. This capacitor consists of an adjustable band around the grid terminal stand-off insulator of the first intermediate amplifier Tube VT-2. The band provides capacity coupling to the grid lead of the first intermediate amplifier tube. By moving this band up and down the stand-off insulator, the amount of coupling or R.F. pickup voltage can be varied to suit individual installation conditions. By moving it closer to the top, or the grid terminal end of the insulator, the pick-up voltage is increased. If the band is moved away from the grid terminal end, towards ground, the pick-up voltage is decreased. Normally, it is set approximately ½ inch from the grid terminal end of the insulator which gives sufficient pick-up for most installations. If adjustment of Capacitor C-68 is found necessary, it

should be locked securely in place after the adjustment has been made.

4-19 Apply plate voltage 3000 volts and filament power, starting the motor-generator by means of START-STOP Switch S-8, S-17. Check FILAMENT VOLTAGE Meter M-11 and adjust if necessary to 10 volts by means of FILAMENT VOLTAGE Rheostat R-6. Set frequency (Control A and B) to desired frequency.

4-20 Operate TEST Key S-10. The M.O. PLATE CURRENT Meter M-7 and M.O. SCREEN GRID CURRENT Meter M-8 should indicate current of about 60 and 11 ma., respectively.

4-21 Set TUNE-OPERATE Switch S-9 to TUNING STEP 2 and adjust Rheostat R-33 until M-9 reads 2000 volts. Operate TEST Key S-10 and adjust DOUBLER CIRCUIT TUNING (Control C) C-14 for maximum indication on Meter M-6 (approximately 68 ma.).

4-22 Adjust 1st INTERMEDIATE AMPLIFIER TUNING (Control D) C-21 for minimum indication on Meter M-6 or maximum indication on Meter M-5 (Approximately 25 ma. on M-6 or 25 ma. on M-5.)

4-23 Adjust 2nd INTERMEDIATE AMPLIFIER TUNING (Control E) L-9 for minimum indication on 2nd INT. AMP. PLATE CURRENT Meter M-4 or for maximum indication on P.A. GRID CURRENT Meter M-3 (approximately 50 ma. on M-4 or 60 ma. on M-3).

4-24 Adjust POWER AMPLIFIER TUNING (Control F) L-14 for minimum indication on P.A. PLATE CURRENT Meter M-2.

4-25 If the antenna is under 50 feet long or over 80 feet long, set ANTENNA FEED Switch S-6 to CURRENT FEED. If between 50 and 80 feet in length, set ANTENNA FEED Switch S-6 to VOLTAGE FEED. (The dimensions are only approximate.)

4-26 If ANTENNA FEED Switch S-6 is in the CURRENT FEED position, set ANTENNA TUNING INDUCTANCE (Control K) L-13 to 0 and adjust ANTENNA TUNING CAPACITOR (Control J) C-42 for maximum output as indicated on ANTENNA CURRENT Meter M-1.

4-27 If the P.A. PLATE CURRENT Meter M-2 indicates over 150 milliamperes, reduce the ANTENNA COUPLING (Control H) C-41 and retune the antenna system as in paragraphs 4-25 and 4-26.

4-28 Set TUNE-OPERATE Switch S-9 to OPERATE and adjust Rheostat R-33 until PLATE VOLTAGE Meter M-9 indicates 3000 volts. Close S-10 and readjust ANTENNA TUNING CAPACITOR (Control J) C-42 for maximum output as indicated on ANTENNA CURRENT Meter M-1. At the same time, adjust ANTENNA COUPLING (Control H) C-41, if necessary, to keep P.A. PLATE CURRENT Meter M-2 to a value *not in excess of 350 milliamperes*. It may also be necessary to slightly readjust POWER AMPLIFIER TUNING (Control F) L-14 for minimum value on P.A. PLATE CURRENT Meter M-2 due to antenna effects. Optimum efficiency is the condition giving maximum indication on ANTENNA CURRENT Meter M-1 with minimum indication on P.A. PLATE CURRENT Meter M-2. Refer to Fig. 31 or Test Data which accompanied this transmitter unit for typical meter readings which were taken with the TUNE-OPERATE SWITCH S-9 on OPERATE.

4-29 NOTE: In order to resonate the antenna, it may be necessary to try various combinations of ANTENNA TUNING INDUCTANCE (Control K) L-13 and CAPACITOR (Control J) C-42, or VOLTAGE or CURRENT FEED to the antenna, to obtain maximum output without the power amplifier being overloaded.

4-30 When operating the transmitter on low power with HIGH-LOW POWER Switch S-5 in the LOW POWER position, the Radio Transmitting Unit should be tuned as described. However, the following exceptions must be observed: The POWER AMPLIFIER TUNING (Control F) L-14 and the P.A. GRID CURRENT Meter M-3 are omitted. The ANTENNA COUPLING (Control H) C-41 is so adjusted that the second intermediate amplifier (now used as a final amplifier) 2nd INT. AMP. PLATE CURRENT Meter M-4 *does not exceed 150 Milliamperes*. It is to be recalled that the upper limiting frequency is 9050 Kcs. in the LOW POWER position.

4-31 The PLATE VOLTAGE Meter M-9 should not exceed 3000 volts when using either HIGH or LOW POWER. This can be adjusted by the PLATE VOLTAGE Rheostat R-33 on the Radio Transmitter Unit. The 2000 volt armature of the high voltage generator unit is used to apply plate voltage (2100 volts maximum) to the Type 860 tubes first and second intermediate amplifier stages. This voltage is indicated on PLATE VOLTAGE Meter M-9 on the Radio Transmitter Unit when TUNE-OPERATE

Switch S-9 is on STEP 2. The PLATE VOLTAGE Meter indicates the voltage which would be applied to the plate of the Type 861 Tube if the HIGH-LOW POWER Switch S-5A was on HIGH POWER.

4-32 After having tuned the Radio Transmitter Unit as described, it can be started, keyed and stopped from a remote position by throwing the LOCAL-REMOTE Switch S-7 to the REMOTE position. When the remote control unit is used, the START-STOP Switch S-8 on the Radio Transmitter Unit must be in the START position. The Radio Transmitter Unit can always be stopped by the local START-STOP Switch S-8, S-17 since this is supervisory over the remote starting switch.

4-33 Each equipment is accompanied by one copy of the actual Government Acceptance Test Data compiled at the Manufacturer's plant and is packed with the equipment. Where the equipment has been subjected to production tests only, the accompanying Test Data will include a copy of complete Type Test Data on similar equipment. This data should be retained on file for reference by the ship or station on which the equipment is installed in order to permit comparison of performance under service and acceptance test conditions.

C. Routine Operation, Transmitter

4-34 Assuming that the transmitter unit has been calibrated for all of the desired operating frequencies and that the master oscillator heater compartment is at operating temperature, routine operation may be accomplished as follows:

(a) TO START AND STOP THE EQUIPMENT (ASSUMING THAT THE TUNING IS CORRECT).

For local control, place LOCAL-REMOTE Switch S-7 to LOCAL. The equipment is then started or stopped by means of START-STOP Switch S-8, S-17. For remote control, place LOCAL-REMOTE Switch S-7 in the REMOTE position. Place START-STOP Switch S-8 in START position. The equipment can then be controlled from a 4-wire or 6-wire remote control unit.

(b) TO CHANGE FREQUENCY

Return control to LOCAL point by placing LOCAL-REMOTE Switch S-7 in LOCAL position for the duration of tuning period.

Open TEST Key S-10.

Set TUNE-OPERATE Switch S-9 to TUNING STEP 2.

Set Controls A to L according to calibration chart, for the desired frequency.

If operating conditions permit, close TEST Key S-10 and note that P.A. PLATE CURRENT Meter M-2 indicates between 150 and 250 ma. Set TUNE-OPERATE Switch S-9 to OPERATE. With key closed, all meters should indicate normally.

(c) TO INCREASE OR DECREASE POWER

To decrease power, rotate generator field Rheostat R-33 counterclockwise until the desired reduction is obtained. Quarter power can be obtained by this method.

To increase power rotate the generator field Rheostat R-33 clockwise until desired power is obtained. Do not exceed 3000 volts, as indicated by PLATE VOLTAGE Meter M-9. If power less than quarter normal is desired, place HIGH-LOW POWER Switch S-5 to LOW position and set Controls E, H, J, K, as calibrated for LOW power. This mode of operation is available for output frequencies between 2000 and 9050 kcs., for CW telegraph transmission.

D. Motor-Generator and Magnetic Controller Operation

4-35 In the following text, refer to Fig. 14, Dwg. W-7300718.

4-36 The sequence of control for applying power to the radio transmitter equipment is as follows: Refer also to paragraph 4-34.

(a) Closing power line Switch applies power to the transmitter for operation of the master oscillator heat control system. In the case of D. C. equipments, this power is at the voltage of the supplying line and appears at the Terminals 9 and 10 on the transmitter. The power is used for the operation of the master oscillator heat control system and the transmitter control circuit.

(b) The master oscillator heat control system and control circuits are protected by Fuses F-1 and F-2. These fuses are connected in the lines from Terminals 9 and 10 in D.C. transmitter units.

(c) To start the motor-generator unit, place LOCAL-REMOTE Switch S-7 to LOCAL and START-STOP Switch S-8, S-17 to START. If EMERGENCY SWITCH S-12, Door Interlocks S-14, S-15, S-16 and master oscillator plate overload Relay, K-7, are all closed, operation of the START-STOP Switch S-8, S-17 will close starting Contactor K-4.

- (d) Closing of Contactor K-4 energizes Contactor K-9 by the action of contacts K-4E, provided main plate overload Relay K-5 is closed. Closing of Contactor K-4 and Contactor K-9 takes place almost simultaneously, and the motor start indicator Light I-2 (Red) and the plate ON indicator Light I-3 (Red) will light.
- (e) Closing of Contactor K-9 connects the high voltage generator field to the terminals of the bias generator through generator field Rheostat R-33. It also connects the low voltage generator field to these same terminals through Resistor R-13. In this manner, the fields of the generators are connected across the bias generator armature when Contactor K-4 closes.
- (f) As starting Contactor K-4 in the D.C. equipment closes, it also completes the magnetic controller solenoid circuit through contact K-4D, which starts the motor-generator. The magnetic controller will function properly after Contactor K-4 has closed provided controller overload Relay K-844, K-854 is closed.
- (g) After magnetic controller Solenoid K-842A-M, K-852A-M has become energized, the action of the D.C. equipment controller is as follows: The main Contact K-842B, K-852B will open. It should be noted that Interlock K-841F, 851F of Contactor K-841, K-851 will prevent Contactor K-842, K-852 from becoming energized unless Contactor K-841, K-851 is open. Interlock K-842C, K-852C will in turn energize main Coil K-843A, K-853A of Contactor K-843, K-853. Its main Contact K-843B, K-853B will open, thereby inserting the whole starting Resistor R-841, R-851 in the motor circuit. Interlock contact K-843C, K-853C will close and complete the circuit to Coil K-841A, K-851A of line Contactor K-841, K-851. This will close and connect the motor to the line with the starting resistor in the circuit. The "make" Interlock K-841E, K-851E will close and seal Contactor K-841, K-851 on the line. The "break" Interlock K-841F, K-851F will open and de-energize contactor Coil K-842A-M, K-852A-M. The accelerating "break" Contact K-841D, K-851D will open and place more impedance in series with Coil K-841A, K-851A. The coil will not draw more current than is necessary to keep the armature sealed once it is pulled in. Contact K-842B, K-852B will remain open after K-842A-M, K-852A-M is de-energized because the holding Coil K-842A-H, K-852A-H has been

energized by a portion of the current flowing through starting Resistor R-841, R-851. This is done by connecting control Resistor R-842, R-852 in parallel with the final portion of R-841, R-851 and then connecting holding Coil K-842A-H, K-852A-H in parallel with R-842, R-852. When starting current flows through Resistor R-841, R-851, part of this current flows through R-842, R-852 and through Coil K-842A-H, K-852A-H. When the motor is at rest, this current is very large and enough flows through K-842A-H, K-852A-H to prevent Contact K-842B, K-852B from closing. As the motor speed increases the current through R-841, R-851 and K-842A-H, K-852A-H decreases. At some predetermined motor speed, the current through K-842A-H, K-852A-H becomes so small that the magnetic pull is not enough to hold the contactor armature in. The armature drops out and K-842B, K-852B closes. The motor speed at which K-842A-H, K-852A-H is de-energized is determined by the position of the tap from K-842A-H, K-852A-H to Resistor R-842, R-852. When main Contact K-842B, K-852B closes it shorts out the first portion of R-841, R-851 and thus completes the first step of the starting cycle. Also, when K-842A-H, K-852A-H is de-energized, interlock Contact K-842C, K-852C will open, thus de-energizing main Coil K-843A-M, K-853A-M. Contact K-843B, K-853B will remain open after Coil K-843A-M, K-853A-M is de-energized, because K-843A-H, K-853A-H remains energized. Coil K-843A-H, K-853A-H is also connected in parallel with R-842, R-852. Since Resistor R-842, R-852 is in parallel with the final portion of R-841, R-851 the current in R-842, R-852 goes up again when Contact K-842B, K-852B shorts out the first section of Resistor R-841, R-851. When the current in R-842, R-852 rises, the current in holding Coil K-843A-H, K-853A-H also rises and Contact K-843B, K-853B remains open. At some predetermined motor speed the current through K-843A-H, K-853A-H becomes so small that the contactor armature drops out and Contact K-843B, K-853B closes. When K-843B, K-853B closes, it shorts out the second or final step of R-841, R-851 and the motor armature is now connected directly across the full line voltage. The speed at which Coil K-843A-H, K-853A-H is de-energized is determined by the position of the tap from K-843A-H, K-853A-H to Resistor R-842, R-852. When Coil K-843A-H,

K-853A-H is de-energized, interlock Contact K-843C, K-853C is opened. This contact is connected in parallel with K-841E, K-851E. When Contactor K-841, K-851 was first energized, K-841E, K-851E closed and shorted out K-843C, K-853C and locked in Contactor K-841, K-851.

(h) Interlock Contact K-842D, K-852D is connected between Terminals T-1 and T-2 in the magnetic controller. This contact is in series with the tube filament supply from the slip rings on the motor. When Contactor K-842, K-852 is energized, K-842D, K-852D opens, thus opening the filament supply line. When K-842, K-852 is de-energized at the end of the first step, Contact K-842D, K-852D closes again and the filament supply line is closed and the filaments are lighted. When K-842D, K-852D closes, the motor has attained sufficient speed so that the filament transformer will not over-

load the circuits. Interlock Contact K-843D, K-853D is in series with keying relay Coil K-1A when 4-wire control is used. When K-843, K-853 is energized, K-843D, K-853D opens and remains open until Contactor K-843, K-853 is de-energized at the end of the second step. By this time the motor has come up to full speed and keying is prevented until the motor has reached proper speed.

(i) The motor will stop when START-STOP Switch S-8, S-17 is placed in the STOP position because one side of the line to line contactor Coil K-841A, K-851A is opened by Contact K-4D. Contactor K-841A, K-851A will be de-energized and disconnect the motor from the line. The motor will also stop if overload Relay K-844, K-854 trips or if the supply voltage fails. If the overload relay has tripped, the motor cannot be started until the relay has been reset.

V. Maintenance

A. General

5-1 Keeping the equipment in good operating condition is absolutely essential to proper performance. Becoming familiar with the design of any equipment is the first essential for obtaining optimum performance. The following points should be observed for this reason, as well as for safety reasons.

5-2 An accurate record should be kept on all vacuum tubes. This record should contain date of receipt, date placed in service, use intended, hours operated, date of failure and other pertinent information. Do not allow hot tubes to chill quickly by coming in contact with cold or moist surfaces as breakage may result. Important information on the care and operation of vacuum tubes will be found under Section VIII VACUUM TUBE DATA.

5-3 Do not adjust zero readings of the meters with power ON. It is desirable to have a grounding rod (insulated rod with a flexible insulated wire fastened at one end of the rod and to ground) to attach to circuits or parts before touching them with the hands. ALWAYS GROUND INTERNAL APPARATUS BEFORE TOUCHING IT, EVEN THOUGH THE POWER SWITCH HAS BEEN OPENED.

5-4 *When servicing the Radio Transmitter Unit always discharge the filter capacitors as some may be holding dangerous charges even though the power may not be on the set. There are bleeder resistors or other circuits across the power filter capacitors, but the additional precaution of grounding the filter capacitors is essential in case the capacitors have not completely discharged. When shutting down the equipment, never reach inside any unit until the motor-generator set has stopped revolving, as dangerous potentials are generated at all speeds. All necessary precautions should be observed to prevent injury to personnel.*

5-5 The appearance of the Radio Transmitting Unit may be maintained by carefully dusting the entire exterior surface daily with a soft dry cloth. Occasionally it may be desirable to clean the back and side shields with a cloth that has been moistened with alcohol or uncolored carbon tetrachloride. When painting within the vicinity of the transmitting equipment, cover the units with wrapping paper so

that the exterior of the set can be kept free from globules of paint. Do not paint over or attempt to finish exteriors of units. If proper care is given, the original exterior finish can be maintained throughout the life of equipment. Molded or composition insulation, capacitor plates and moving mechanical parts should be cleaned with a dry cloth, care being taken that no scratching or damage is performed during the cleaning process. Where DRY compressed air is available, it should be used to blow the dust from the interior of the set. In the absence of a dry compressed air source, a hand bellows should be used.

5-6 When cleaning, never pull or strain the wiring, as continued movement may cause breaks which are difficult to locate and repair. The felt strips between the wire clamps and the wire should be kept in place to prevent chaffing of the wire.

B. Transmitter

5-7 Relays should be inspected regularly for rust, noise, and condition of contacts. If the contacts have become rough, they should be smoothed with a jeweler's file or crocus cloth. If badly burned they should be replaced with spares. Rust on the magnet armature or pole faces may cause noise and chattering and should be removed carefully. Do not OIL OR GREASE RELAY BEARINGS as oil will collect dirt and introduce friction. To neglect relays or bearings may result in serious trouble which may be difficult to locate. For the care, operation and maintenance of the relays, see Figs. 25 and 27.

5-8 Keying Relay K-1 should be checked regularly to see that the contacts are clean and the keying action is satisfactory. DO NOT ADJUST CONTACTS UNLESS ABSOLUTELY NECESSARY. The contacts of the keying relay are set at the factory with an oscillograph to produce proper keying. It is imperative that they be left as set, unless adjustment is absolutely necessary to eliminate arcing or to correct faulty keying. The contacts then should be adjusted as shown on Fig. 25.

5-9 Special care should be observed in keeping all switches in good condition, keeping them clean and with good contacts. The switch bearings should be given an occasional drop of oil.

5-10 Slider guides and contacts on the rotating coils should be kept clean and free from binding. A very thin application of Vaseline may be used on the coils to prevent roughening of the copper.

5-11 In order to obtain the extreme frequency stability of which the Radio Transmitter Unit is capable, the master oscillator unit should be kept in excellent condition. Inspect the unit regularly to see that the heated compartment is holding temperature correctly and the thermostat Relay K-20 functions properly. Keep thermostat Relay K-20 contacts in good condition and replace them with spares if they become badly worn. It is advisable to keep the heater compartment up to temperature continuously if possible. This prevents large variations in temperature of all parts of the frequency control circuit. All connections in the master oscillator unit should be kept tight and free from corrosion or dirt. Usually, any trouble in unstable frequency can be traced to loose or dirty connections in the master oscillator unit.

5-12 Calibration Reset Capacitor C-61 is located in the master oscillator heat compartment. Adjustment is made from the front panel of the unit by unlocking the knurled lock-nut (see Figure 1) and inserting a long slender screwdriver in the hole provided. The adjustment changes the capacity of a small variable capacitor. In this manner, small changes in dial calibration due to aging of parts or changing of master oscillator tubes may be corrected.

5-13 Access to all parts of the master oscillator assembly, that may need servicing at any time, may be obtained from the left hand side of the Radio Transmitter Unit. This is accomplished by removing the left hand side shield of the Radio Transmitter Unit, the shield of the master oscillator assembly and the heat compartment cover. All parts of the master oscillator with the exception of doubler circuit coupling Capacitor C-13, M.O. plate choke grounding Capacitor C-12, doubler circuit tuning Capacitor C-14, 1st Int. Amp. grid coupling Capacitor C-15, doubler tank Coil L-3 and M.O. Plate Choke L-4 are then accessible.

5-14 If necessary to correct trouble in the doubler circuit consisting of parts C-13, C-12, C-14, C-15, L-3, and L-4, the master oscillator unit should be removed from the frame as follows:

(a) Remove the left side and rear screens on the Radio Transmitter Unit frame. Remove the mid-section of the left back frame angle by unbolting

it from the gussets. This frame angle is $39\frac{3}{8}$ inches long and secured by four machine screws at each end.

- (b) Disconnect all connections to the unit at the main frame terminal blocks on the bottom, front and top. Do not overlook the grid connection at the right side of the unit. Mark leads for convenience in replacement.
- (c) Remove the rubber buffet pads and braces across the left side and back of the unit.
- (d) Secure a block of wood approximately 2"x4" having a length of approximately 10".
- (e) Slip this block on the frame floor in order to support the master oscillator unit. Loosen the hose clamps between the fan and the unit.
- (f) Mark the position of locknuts on turnbuckles, tying them with a string. Then, loosen the turnbuckles as far as they will extend. The locknuts provided on the turnbuckles are set for proper suspension and position of the master oscillator unit and should not be moved.
- (g) Reach underneath to the right hand corner of the unit and slip a wire loop through the end of the spring where it catches into the spring hook. Pull the spring with the wire loop and guide the spring out of the hook. The other three springs can be similarly unhooked.
- (h) Disconnect all the top springs from the unit.
- (i) With one man grasping the master oscillator unit at the back, and another at the front through the tube door, gently slide the unit out through the opening at the left side of the main frame. The unit can be rested on the block while changing hand holds. Be careful not to damage the fan motor.

5-15 The unit can be replaced in the main frame by reversing the process described in Par. 5-14.

5-16 The rubber used in this equipment for shock-mounting should be inspected regularly and should be replaced if it becomes badly cracked. The rubber used for the tube mountings may be replaced by removing the mounting screws from the holders. The rubber used for cushioning the master oscillator unit may be replaced by first removing the unit from the main frame, following the instructions given above.

5-17 Mercury thermostats and mercury or spirit thermometers are delicate instruments which should be handled with extreme care to avoid breakage. In spite of such care, the column may separate while the glass is intact. In such situations, it is

usually practicable to reunite the column by placing the instrument in a beaker of water at a temperature of about 40°C. Then, gradually add warmer water until the column reunites. In case of a thermostat operating at 60°C. the final temperature of the water in the beaker will rarely have to exceed 65° to 75°C. After the column is reunited the instruments should be gradually cooled and then tested for proper operation.

5-18 Where thermostats with leads are supplied for use or as replacements in equipment provided with mounting clips which do not require leads, it is preferable to cut the leads carefully rather than using a soldering iron. The reason for such care is that the leads are soldered to rings, on the thermostat, constructed of copper wire and solder which in turn connect with the platinum wires extending through the glass to make contact with the mercury.

C. Motor-Generator and Magnetic Controller

5-19 The magnetic controller or controllers require very little care except for inspection of the contactors. Roughened appearance of contacts is no indication that good contact is not being obtained. If the contacts become badly pitted or blackened, they may be cleaned and smoothed with a fine file and fine sandpaper. The copper contacts should be renewed when the tips are burned away to the extent that the current carrying surfaces are materially affected. Neglect to change contact tips may cause an arc to burn the contact screw, making it difficult to remove.

5-20 BE SURE THERE IS NO VOLTAGE ON THE CONTROLLER WHEN SERVICING. OPEN MAIN LINE SWITCH. Push the contactors closed by hand to see that no friction is present and to make sure of proper contact alignment.

5-21 Friction may be removed by lining up the bearings. DO NOT USE OIL.

5-22 The bearings of the hinge pin and armature shaft require no lubrication. Oil quickly collects dust, and unless parts are frequently cleaned, will interfere with the operation of the contactor. The sealing surfaces of the magnet core and armature should be kept clean to insure proper contact.

5-23 The commutators of the motor generator units should be inspected occasionally to see that the brushes are not sparking excessively and that the commutators are not burned or grooved. The commutators must be kept clean and the brushes properly

adjusted and fitted to the curvature of the commutators. No other attention is required by the commutator when it is taking on a polish and shows no signs of wear. *The commutators should never be lubricated.* If they become slightly rough they may be polished with a piece of fine sand-stone ground to fit. In any case, the final smoothing should be done with fine (No. 00) sandpaper. When using paper or stone, lift the brushes and do not replace them until all grit is removed. CAUTION: NEVER USE EMERY CLOTH OR EMERY PAPER ON THE COMMUTATORS. NEVER ATTEMPT TO MAKE REPAIRS TO COMMUTATORS AND BRUSHES WHILE THE MACHINE IS RUNNING, AS THE VOLTAGES ARE DANGEROUS TO LIFE. TURN THE MOTOR-GENERATOR OVER BY HAND. The brushes are set in position at the factory, for best commutation. This adjustment should not be altered. New brushes should be the same make and grade as those shipped with the machines. When new brushes are installed, the pig-tails should be free and flexible. Spring tension on brushes should be adjusted for 3 to 5 pounds per square inch.

5-24 The bearings of the motor-generator unit should be inspected regularly to make sure that they have proper lubrication. See paragraph 5-32.

5-25 The method of securing the motor and generators to the bedplate is by means of bolts, screwed into tapped holes in the bedplate.

5-26 All machines are dowelled as any misalignment will cause excessive ripple voltage. Special dowel pins are used which permit the pins to be removed from the holes. The units CAN BE LIFTED FROM THE BEDPLATE BY REMOVING THE BOLTS AND DOWEL PINS. The shafts are designed to permit disengaging the coupling without moving the units apart.

D. Lubrication

5-27 The tuning dial bearings, the rotating coil bearings, variable capacitor bearings, and the switch bearings should be lubricated at least once in every six months with a few drops of a light penetrating oil such as a good typewriter oil.

5-28 The contact surfaces of the rotating coils and their sliding contacts should be lubricated with Vaseline if they show signs of cutting or binding.

5-29 The switch contacts and blades should be lubricated with a thin coat of Vaseline. DO NOT LUBRICATE THE MASTER OSCILLATOR RANGE SWITCH contacts S-1.

5-30 No excess Vaseline should remain on the contact surfaces.

5-31 Blower Motor B-1 in the master oscillator compartment is fitted with ball bearings and should be greased once or twice a year, depending upon the service, with Navy Grade 14L3 medium grease. The bearings should never be more than two-thirds full.

5-32 The motor-generator is equipped with ball bearings, and is shipped with sufficient grease in the bearings to provide for six months or more of service. Do not screw down the grease cups unless the bearings actually require lubrication. Excessive grease is detrimental to ball bearings. A hot bearing is not an indication of insufficient lubrication, but rather may be caused by an excess of grease. Clicking bearings is an indication of insufficient lubrication or possibly a defective bearing. At intervals of about six months or more of service (for normal operation) the bearings should be greased. Use a high grade sodium base, clean, ball bearing grease, similar to that supplied with the set, or Navy Grade 14L3 Soft. When lubricating, remove bearing drain plug and with set running, force in clean grease via the grease cups until clean grease appears at the outlets. Allow set to operate for about fifteen minutes and then replace drain plugs. At intervals of about two years, the bearing caps should be removed and the bearings washed out and repacked with clean grease. KEEP GREASE AND BEARINGS CLEAN, DIRT DESTROYS BALL BEARINGS.

E. Maintenance Schedule

5-33 A MAINTENANCE SCHEDULE, BASED ON THE FOLLOWING HINTS, AND STRICTLY ADHERED TO, WILL DO MUCH TO KEEP THE RADIO TRANSMITTER UNIT IN GOOD OPERATING CONDITION WITH A MINIMUM OF SHUT-DOWN TIME.

(1) Daily:

- a. Check all control circuits for proper operation.
- b. Check and record all meter and thermometer readings in log book.
- c. Check tuning of equipment on at least three frequencies.
- d. Dust exterior of equipment.

(2) Weekly:

- a. Carefully clean entire equipment.
- b. Inspect and tighten all electrical connections.
- c. Clean and inspect all contactor and relay contacts.
- d. Clean all switch blade contacts.

(3) Monthly:

- a. Check all tubes. This can be done by checking the daily meter readings in the log of the transmitter. Any gradual change in the tube will be indicated by a gradual change in plate current, all other factors being constant. The tubes in need of replacement can thereby be attended to without serious loss of power.

(4) Yearly:

- a. Clean and repack the bearings of the Blower Motor.

F. Troubles and Causes

5-34 OPERATING START-STOP SWITCH S-8, S-17 ON THE RADIO TRANSMITTER UNIT DOES NOT OPERATE THE STARTING SOLENOID.

- a. Some access door open.
- b. REMOTE-LOCAL Switch S-7 in wrong position.
- c. Overload relays not reset.
- d. Power supply switch open.
- e. No line voltage, or line voltage too low.
- f. EMERGENCY SWITCH S-12 open.
- g. Fuse F-2 open.

5-35 START-STOP SWITCH S-8, S-17 CAUSES STARTING CONTACTOR TO CLOSE, BUT MOTOR-GENERATOR UNIT DOES NOT START.

- a. Open connection to motor-generator or controller unit.
- b. Controller overload relay tripped.

5-36 MOTOR-GENERATOR UNIT OPERATES SATISFACTORILY BUT LOW PLATE VOLTAGE AT RADIO TRANSMITTER UNIT.

- a. Overload relays not reset.
- b. TUNE-OPERATE Switch S-9 in TUNING STEP 1.
- c. Open connection to motor-generator unit.
- d. Field Contactor K-9 not closed.
- e. No filament voltage.
- f. Transformer connection open.
- g. Starting Contactor K-4 not closed.

5-37 OPERATING TEST KEY CAUSES NO INDICATION ON MASTER OSCILLATOR METERS.

- a. Keying Relay K-1 inoperative.
- b. Dirty keying contacts.
- c. No plate voltage on master oscillator.
- d. Open grid leak.
- e. Open screen or plate series resistor.
- f. Screen by-pass or plate by-pass capacitor broken down.
- g. Open interlock circuit or range switch.

5-38 TUNING DOUBLER TUNING CIRCUIT CAUSES EXTREME REACTION ON MASTER OSCILLATOR SCREEN CURRENT AND FREQUENCY.

- a. Inaccurate setting Dial "C." Doubler circuit tuned to fundamental instead of harmonic frequency.

5-39 FIRST INTERMEDIATE AMPLIFIER DOES NOT RESONATE.

- a. Doubler tuning circuit improperly tuned.
- b. Range Switch S-2 in wrong position.

5-40 CIRCUITS OPERATE SATISFACTORILY, BUT NO ANTENNA CURRENT OR POWER AMPLIFIER LOADING.

- a. Antenna circuits out of resonance.
- b. Antenna shorted or open.
- c. Antenna ammeter open.
- d. Auxiliary screen grid connection off of Type 861 amplifier tube.

5-41 SET OPERATES NORMALLY WHEN KEY IS DOWN BUT AMPLIFIER TUBES DO NOT BLOCK WHEN KEY IS UP.

- a. Insufficient bias on tubes. Check brushes on bias generator.
- b. Open connection to bias generator, check fuse.
- c. Defective amplifier tube.
- d. Ground on keying circuit causes master oscillator to run continuously.

5-42 AMPLIFIER TUBE HEATS EXCESSIVELY WHEN KEY IS CLOSED AND ANTENNA CIRCUIT IS IN TUNE.

- a. Antenna too tightly coupled.
- b. Excessive plate voltage.
- c. Defective amplifier tube.

5-43 OPERATING START-STOP SWITCH S-8, S-17 IN THE TRANSMITTER UNIT DOES NOT START MOTOR GENERATOR.

- a. Main line switch open.
- b. Some access door on transmitter unit open.

- c. Magnetic controller or transmitter overload relays not reset.

- d. No line voltage, or line voltage too low.

5-44 MAGNETIC CONTROLLER OPERATES, BUT OVERLOAD RELAY TRIPS TOO QUICKLY.

- a. Overload relay set too low.
- b. Not enough current in holding coil of accelerating Contactors K-842, K-852 and K-843, K-853.

G. Circuit Checking, General

5-45 In case trouble appears to be in the interlock circuits of the doors or switches, terminals are provided on the transmitter terminal board which permit circuit checking to definitely locate such trouble. Switch Interlocks S-1C, S-9B and S-2A which are normally connected in the keying circuit are connected between terminals 19 and 20 of the terminal board. This wiring provides the following possible circuit checking.

1. Test between Terminals 19 and 20. Check should show complete short circuit (zero ohms) if Interlock Switches S-1C, S-9B and S-2A are operating properly. An open circuit would indicate that one or more of the above interlocks is open.
2. Test between Terminal 20 and 6 with LOCAL-REMOTE Switch S-7 in REMOTE position. Check should indicate approximately 625 to 850 ohms (the value of K-1 and K-2 coils in parallel). If the check indicates a higher resistance circuit, K-1 or K-2 coil circuit is defective.
3. Test between S-18F and Terminal 13. Check should indicate a short circuit. If check does not indicate a short circuit, overload relay contact K-5B is open.
4. Test between Terminal 12 and Terminal 40. Door Interlocks S-14, S-15 and S-16 and the Low Voltage Overload Relay K-7 contacts are in series between these terminals. The check between these terminals should show a complete short circuit (zero ohms) if all interlocks are functioning properly. An open circuit indicates that one or more of the door interlocks or the Overload Relay K-7 contacts are not completing the circuit.

5-46 In case of an emergency, temporary operation can be obtained if interlocks are out of order by shorting between Terminals 19 and 20 or 12 and 40.

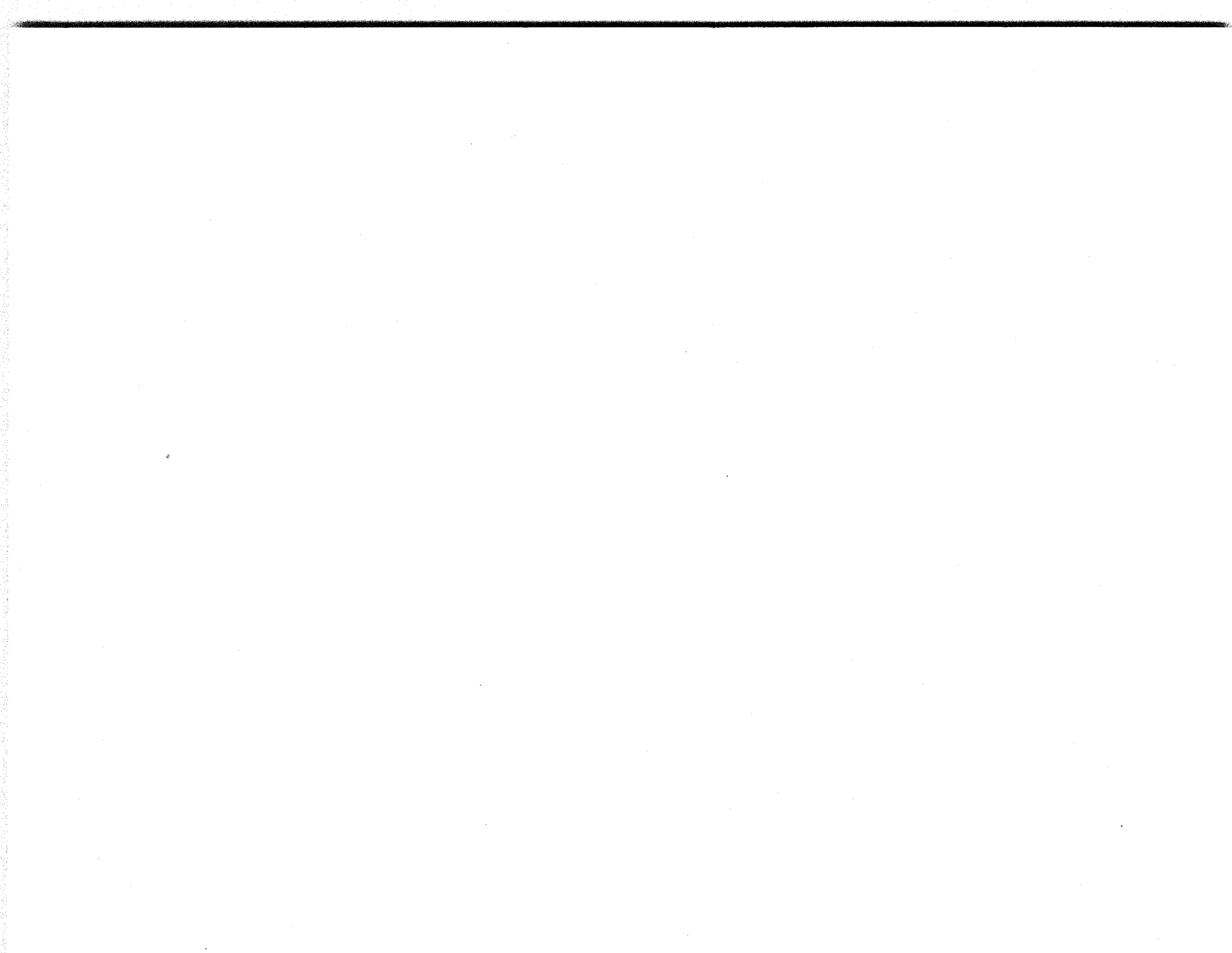

TABLE I
LIST OF MAJOR UNITS
MODEL TBK-20 RADIO TRANSMITTING EQUIPMENT

QUANTITY		SYMBOL GROUP	NAVY TYPE DESIGNATION	NAME OF MAJOR UNIT	ASSEMBLY DRAWING NUMBER
115 DC	230 DC				
1		1 TO 99	CAY-52217	TRANSMITTER	DL-7502613 G-1
	1	1 TO 99	CAY-52218	TRANSMITTER	DL-7502613 G-2
X	X	211 TO 220	CAY-21679	LOW VOLTAGE AND BIAS GENERATOR	DL-7502615 L-21
X	X	221 TO 240	CAY-21680	HIGH VOLTAGE GENERATOR	DL-7502615 L-20
	X	241 TO 260	CAY-21681	MOTOR	DL-7502615 L-19
X		271 TO 290	CAY-21678	MOTOR	DL-7502615 L-5
	1	211 TO 260	CAY-21681	MOTOR GENERATOR COMPLETE	DL-7502615 G-2
1		211 TO 240, 271 TO 290	CAY-21675	MOTOR GENERATOR COMPLETE	DL-7502615 G-1
1		841 TO 850	CAY-211231	MAGNETIC CONTROLLER	DL-7502882 G-2
	1	851 TO 860	CAY-211232	MAGNETIC CONTROLLER	DL-7502882 G-1

1-9

NOTE - THIS SPARE PARTS LIST HAS BEEN COMPILED IN ACCORDANCE WITH NAVY SPECIFICATION RE13A730B WITH MODIFICATIONS AS DIRECTED BY THE RESIDENT INSPECTOR OF NAVAL MATERIAL AND APPROVED IN ACCORDANCE WITH BUREAU OF SHIPS LETTER. TO ALL INSPECTORS SERIAL 1095 (930 C B) EN28/A2-11 DATED 11 MAY 1944.

PARTS AND SPARE PARTS FOR TBK-20 RADIO TRANSMITTING EQUIPMENT										SPARE PARTS		
TOTAL USED PER EQUIP	SYMBOL DESIG.	FUNCTION	DESCRIPTION	NAVY TYPE NUMBER	NAVY SPEC. NUMBER	MFR.	MFR. DESIG.	CONTRACTOR'S ITEM NO.	CONTRACTOR'S DRAWING NUMBER	EQUIP		ALL SYMBOL DESIGNATIONS INVOLVED
										BOX NUMBER	QUANTITY	
115 DC 230 DC												
1	1	B-1	BLOWER MOTOR	115 V.D.C. 3000 R.P.M. 1/75 H.P.	-21131B	17-M-9C	1 S#952446	1	7607280 P-1	1	B1	
2	2	B-1A	BEARINGS FOR B-1				1 2-D-695 IT.9	2	7607280 P-2	2	B1A	
2	2	B-1B	BRUSHES FOR B-1				1 8-D-2461 IT.2	3	7607280 P-3	10	B1B	
2	2		HOLDER FOR B-1B				1 8-D-2457 G-1	4	8-D-2483 P2	2		
2	2		SPRING FOR B-1B				1 426293	5	S#952446A	3		
								6				
0	1	B-241	MOTOR FOR M.G. SET	230 V.D.C.	-21681		1	7		0	B-241	
1	0	B-271	MOTOR FOR M.G. SET	115 V.D.C.	-21678		1	8		0	B-271	
2	2	C1	CAPACITOR - M.O. TANK	0.00075 MFD. ±2%, 5000 V. EFF. TEST 2500 V. WORKING #(5,3,5,2,1), MICA CONSTANT CAPACITY AT 60° C.	-48477 D2	RE48AA131C	2 654-6H 17 1550-H-215	9	7607280 P15	1	C1,C3	
1	1	C2	CAPACITOR - M.O. TANK	0.003 MFD. ±2%, 3000 V. EFF. TEST 1500 V. WORKING #(8,6,4,2) MICA CONSTANT CAPACITY 60° C.	-48365 D2	RE48AA131C	2 655-6H 17 1550-H-225	10	7607280 P16	1	C2	
X	X	C3	CAPACITOR - M.O. TANK	SAME AS C1	-48477 D2			11	7607280 P17			
10	10	C4	CAPACITOR - M.O. FILAMENT BY-PASS	0.01 MFD., ±10%, 1000 V. TEST, 600 VOLTS WORKING, MICA	-48027-10	RE48AA112N	20	12	7607280 P18	2	C4,C5,C8,C9,C17,C18,C26,C27,C35,C36	
2	2		BRACKET FOR C-4	MICARTA ANG. 1 OF 1 7/8 X 5/8 X 1/8 TK.			1 7705580 P3	13	7406181 P2	0	C4, C12	
X	X	C5	CAPACITOR - M.O. FIL. BY-PASS	SAME AS C-4	-48027-10			14	7607280 P19			
1	1	C6	CAPACITOR - M.O. SCREEN BY-PASS	0.1 MFD. ±5%, 1000 V. TEST EFF. 600 V. WORKING S(18,15,12,7) MICA	-48478 B5	RE48AA1316	20	15	7607280 P20	1	C6	
1	1	C7	CAPACITOR - GRID BY-PASS	0.015 MFD. ±2%, 1500 VOLTS TEST EFF. 750 VOLTS WORKING #(12,10,7,4)MICA CONSTANT CAPACITY 60° C.	-48204 D2	RE48AA131C	2 140-6H 17 1550-H-311	16	7607280 P21	1	C7	

PARTS AND SPARE PARTS FOR TBK-20 RADIO TRANSMITTING EQUIPMENT										SPARE PARTS		
TOTAL USED PER EQUIP	SYMBOL DESIG.	FUNCTION	DESCRIPTION	NAVY TYPE NUMBER	NAVY SPEC. NUMBER	MFR.	MFR. DESIG.	CONTRACTOR'S ITEM NO.	CONTRACTOR'S DRAWING NUMBER	EQUIP		ALL SYMBOL DESIGNATIONS INVOLVED
										BOX NUMBER	QUANTITY	
115 DC	230 DC											
X	X	C8	CAPACITOR M.O. FIL. BY-PASS	SAME AS C4	-48027-10			17	7607280 P22			
X	X	C9	CAPACITOR M.O. FIL. BY-PASS	SAME AS C4	-48027-10			18	7607280 P23			
11	11	C10	CAPACITOR M.O. SCREEN CURRENT METER BY-PASS	0.006 MFD. ±10%, 1000 V. TEST, 600 V. D.C. WORKING, MICA. SUPPLY TYPE "E" BRACKETS SEPARATELY	-48410-10	RE-48AA112N	20	19	7607280 P24	0	C10	
0	0		CAPACITOR - SPARE FOR C10	SAME AS C10, EXCEPT OMIT "E" BKTS.	-48410-10		20	20	7607280 P14	3	C10, C11, C23, C24, C31, C32, C43, C46, C50, C51, C52	
X	X	C11	CAPACITOR - M.O. SCREEN CURRENT METER BY-PASS	SAME AS C10	-48410-10			21	7607280 P25			
6	6	C12	CAPACITOR - M.O. PLATE BY-PASS	0.002 MFD., ±10%, 5000 V. TEST, 2500 V.D.C. WORKING MICA.	-48037-10	RE48AA112N	20	22	7607280 P26	2	C12, C16, C25, C33, C34, C37	
X	X		BRACKET FOR C12	SAME AS ITEM 13				23				
1	1	C13	CAPACITOR - DOUB. CIRCUIT COUPLING	0.000031 MFD. MAX., 0.000006 MFD. MIN., 0.0715" SPACING, VARIABLE AIR			3	MCD-35MX	24	7607280 P27	0	C13
1	1	C14	CAPACITOR - DOUB. TUNING	0.00075 MFD. MAX., 0.000024/MFD. MIN. VARIABLE AIR			4	X-750-ES	25	7605863 P4	0	C14
1	1	C15	CAPACITOR - 1ST INT. GRID. COUP.	0.00007 MFD. ±10%, 5000 V. TEST, 2500 V.D.C. WORKING, MICA.	-48039-10	RE48AA112N	20	26	7607280 P29	1	C15	
1	1		PLATE FOR C15	MICALEX 2 1/2 X 2 1/2 OF 1/4 TK.			1	7705830 P2	27	7705830 P2	1	C15
X	X	C16	CAPACITOR - 1ST INT. GRID CHOKE BY-PASS	SAME AS C12	-48037-10			28	7607280 P30			
8	8		BRACKET FOR C16	MICARTA ANG. 1 OF 2 X 5/8 X 1/8 TK.			1	7405902 P3	29	7707737 P3	0	C16, C19, C25, C28, C34, C35, C36, C37
X	X	C17	CAPACITOR - 1ST. INT. FIL. BY-PASS	SAME AS C4	-48027-10			30	7607280 P31			
2	2		BRACKET FOR C17 & C18	MICARTA ANG 2 1/4 OF 5/8 X 1 7/8 X 1/8 TK.			1	7405902 P5	31	7707737 P4	0	C17, C18, C26, C27
X	X	C18	CAPACITOR - 1ST. INT. FIL. BY-PASS	SAME AS C4	-48027-10			32	7607280 P32			
2	2	C19	CAPACITOR - 1ST. INT. SCREEN BY-PASS	0.01 MFD., ±10%, 2500 V.D.C. TEST 1200 V.D.C. WORKING, MICA	-48035-10	RE48AA112N	20	33	7607280 P33	1	C19, C28	

PARTS AND SPARE PARTS FOR TBK-20 RADIO TRANSMITTING EQUIPMENT										SPARE PARTS		
TOTAL USED PER EQUIP	SYMBOL DESIG	FUNCTION	DESCRIPTION	NAVY TYPE NUMBER	NAVY SPEC. NUMBER	MFR.	MFR. DESIG.	CONTRACTOR'S ITEM NO.	CONTRACTOR'S DRAWING NUMBER	EQUIP		ALL SYMBOL DESIGNATIONS INVOLVED
										BOX NUMBER	QUANTITY	
115 DC												
230 DC												
X X		BRACKET FOR C19	SAME AS ITEM 29					34				
2 2	C20	CAPACITOR - 1ST INT. PLATE BY-PASS	0.01 MFD., ±10%, 5000 V.D.C. TEST, 2500 V.D.C. WORKING, MICA	-48382-10	RE48AA112N	20		35	7607280 P34	1		C20, C30
1 1	C21	CAPACITOR - 1ST INT. TUNING	0.00045 MFD. MAX., 0.000045 MFD. MIN., 0.08" SPACING, VARIABLE AIR			3	TC-450-BW	36	7607256 P3	0		C21
20 20		INSULATOR FOR C21	ISOLANTITE 2 3/8 X 1 X 1/4 TK.			3		37		0		C21, C29, C39
1 1	C22	CAPACITOR - 2ND INT. GRID COUPLING	0.00025 MFD., ±10%, 5000 V. TEST 2500 V.D.C. WORKING, MICA	-48330-10	RE48AA112N	20		38	7607280 P36	1		C22
13 13		INSULATOR FOR C22	ISOLANTITE - TAPERED 1 TO 1/2 X 1 LG.	-61028		23	7602239 P1	39	7406187 P2	7		C22, C55, R22, S4A, S4B, VT4 CONN.
7 7		BINDING POST FOR C22				24	7407125 P1	40	7406187 P5	0		C22, C68
1 1		STUD FOR C22	BRASS 21/32 LG. SPECIAL			1	7400705 P12	41	7406187 P7	0		C22
1 1		STUD FOR C22	BRASS 1 1/8 LG. SPECIAL			1	7406187 P9	42	7406187 P9	1		C22
X X	C23	CAPACITOR - 1ST INT. PLATE CURRENT METER BY-PASS	SAME AS C10	-48410-10				43	7607280 P37			
X X	C24	CAPACITOR - 2ND INT. PLATE CURRENT METER BY-PASS	SAME AS C10	-48410-10				44	7607280 P38			
X X	C25	CAPACITOR - 2ND. INT. GRID CHOKE BY-PASS	SAME AS C12	-48037-10				45	7607280 P39			
X X		BRACKET FOR C-25	SAME AS ITEM 29					46				
X X	C26	CAPACITOR - 2ND INT. AMP. FIL. BY-PASS	SAME AS C4	-48027-10				47	7607280 P40			
X X		BRACKET FOR C-26, C-27	SAME AS ITEM 31					48				
X X	C27	CAPACITOR - 2ND INT. AMP. FIL. BY-PASS	SAME AS C4	-48027-10				49	7607280 P41			
X X	C28	CAPACITOR - 2ND INT. SCREEN BY-PASS	SAME AS C19	-48035-10				50	7607280 P42			

1-9

PARTS AND SPARE PARTS FOR TBK-20 RADIO TRANSMITTING EQUIPMENT										SPARE PARTS		
TOTAL USED PER EQUIP	SYMBOL DESIG.	FUNCTION	DESCRIPTION	NAVY TYPE NUMBER	NAVY SPEC. NUMBER	MFR.	MFR. DESIG.	CONTRACTOR'S ITEM NO.	CONTRACTOR'S DRAWING NUMBER	EQUIP.		ALL SYMBOL DESIGNATIONS INVOLVED
										BOX NUMBER	QUANTITY	
115 DC	230 DC											
X	X		BRACKET FOR C28					51				
1	1	C29	CAPACITOR - 2ND INT. AMP. TUNING			3	TCD-320-BW	52	7607256 F2	0		C29
								53				
X	X		INSULATOR FOR C29					54	7607288 F5	8		C29, C39, S5A, S5B, S5C
15	15		INSULATOR FOR C29	-61084		23	7602239 P39	54	7607288 F5	8		C29, C39, S5A, S5B, S5C
								55	7406747 F4	0		C29, C39
2	2		WORM FOR C29			25	7406747 P4	55	7406747 F4	0		C29, C39
2	2		WORM WHEEL FOR C29			25	7808130 P1	56	7607288 F4	0		C29, C39
X	X	C30	CAPACITOR - 2ND INT. AMP. PLATE BY-PASS	-48382-10				57	7607280 P44			
X	X	C31	CAPACITOR - P.A. PLATE CURRENT METER BY-PASS	-48410-10				58	7607280 P45			
X	X	C32	CAPACITOR - P.A. GRID CURRENT METER BY-PASS	-48410-10				59	7607280 P46			
X	X	C33	CAPACITOR - P.A. GRID BLOCKING	-48037-10				60	7607280 P47			
X	X	C34	CAPACITOR - P.A. GRID CHOKE BY-PASS	-48037-10				61	7607280 P48			
X	X		BRACKET FOR C34					62				
X	X	C35	CAPACITOR - P.A. FIL. BY-PASS	-48027-10				63				
X	X		BRACKET FOR C35					64				
X	X	C36	CAPACITOR - P.A. FIL. BY-PASS	-48027-10				65	7607280 F50			
X	X		BRACKET FOR C36					66				
X	X	C37	CAPACITOR - P.A. SCREEN BY-PASS	-48037-10				67	7607280 P51			
X	X		BRACKET FOR C37					68				
		C38	NOT USED									

PARTS AND SPARE PARTS FOR TBK-20 RADIO TRANSMITTING EQUIPMENT										SPARE PARTS			
TOTAL USED PER EQUIP	SYMBOL DESIG.	FUNCTION	DESCRIPTION	NAVY TYPE NUMBER	NAVY SPEC. NUMBER	MFR.	MFR. DESIG.	CONTRACTOR'S ITEM NO.	CONTRACTOR'S DRAWING NUMBER	EQUIP		ALL SYMBOL DESIGNATIONS INVOLVED	
										BOX NUMBER	QUANTITY		
115 DC	230 DC												
	1	C39	CAPACITOR - P.A. TUNING				3	TCD-320-JW	69	7607256 P1		0	C39
X	X		INSULATOR FOR C39						70				
X	X		INSULATOR FOR C39						71				
X	X		WORM FOR C39						72				
X	X		WORM WHEEL FOR C39						73				
	1	C40	CAPACITOR - P.A. PLATE BY-PASS	-481215-5	RE-48AA131C		2 17	592-6P 1550-335	74	7607280 P54		1	C40
	1	C41	CAPACITOR - ANT. COUPLING				1		75	7604452 G7		0	C41
8	8		INSULATOR FOR C41	.61030			23	7602239 P3	76	7604452 P15		4	C41, VT3, VT4
	1		CONTACT FOR C41				1	7806535 P1	77	7604452 P12		2	
	1		LEAD SCREW FOR C41				1	7405851 P2	78	7604452 P10		0	
	1		SLEEVE FOR C41				1	7405851 P5	79	7604452 P11		0	
	1		SPRING FOR C41				1	7807490 P1	80	7604452 P6		0	
	1	C42	CAPACITOR - ANT- TUNING				4	TK-300-US	81	7607403 P1		0	C42
	2		STRIP FOR C42				4		82			1	
X	X	C43	CAPACITOR - P.A. PLATE CURRENT METER BY-PASS						83	7607280 P57			
	1	C44	CAPACITOR - ANT. H.V. BLOCKING	-48218-5	RE48AA131				84	7607280 P58		1	C44
	3	C45	CAPACITOR - KEYING RELAY ARC SUPPRESSOR	-48686-10	RE13A488C		2 21 17	TJ-6010	85	7607280 P59		2	C45, C63, C64

PARTS AND SPARE PARTS FOR TBK-20 RADIO TRANSMITTING EQUIPMENT											SPARE PARTS		
TOTAL USED PER EQUIP		SYMBOL DESIG.	FUNCTION	DESCRIPTION	NAVY TYPE NUMBER	NAVY SPEC. NUMBER	MFR.	MFR. DESIG.	CONTRACTOR'S ITEM NO.	CONTRACTOR'S DRAWING NUMBER	EQUIP.		ALL SYMBOL DESIGNATIONS INVOLVED
115 DC	230 DC										BOX NUMBER	QUANTITY	
X	X	C46	CAPACITOR - FIL. VOLTMETER BY-PASS	SAME AS C10	-48410-10				86	7607280 P60			
1	1	C47	CAPACITOR - M.O. PLATE VOLTAGE FILTER	4 MFD., ±10%, 1000 V.D.C. WORKING, PAPER	-48683-10	RE13A488	TYPE FL		87	7607280 P61	1	C47	
1	1	C48	CAPACITOR - BIAS FILTER	6 MFD., ±10%, 600 V.D.C. WORKING, PAPER	-48684-10	RE13A488	1 TYPE FL		88	7607280 P62	1	C48	
1	1	C49	CAPACITOR - PLATE VOLTMETER MULTIPLIER BY-PASS	0.001 MFD. ±5%, 7500 V. TEST EFF. 3500 V. WORKING, MICA	-481216-5	RE13A389K	2 246-6P		89	7607280 P63	1	C49	
X	X	C50	CAPACITOR - P.A. TUBE HOUR METER BY-PASS	SAME AS C10	-48410-10				90	7607280 P64			
X	X	C51	CAPACITOR - BIAS VOLTMETER BY-PASS	SAME AS C10	-48410-10				91	7607280 P65			
X	X	C52	CAPACITOR - PLATE VOLTMETER BY-PASS	SAME AS C10	-48410-10				92	7607280 P66			
1	1	C53	CAPACITOR - 2ND INT. AMP. TANK	0.00015 MFD. ±5%, 5000 V. TEST EFF. 2500V. WORKING, 7.5 AMPS. AT 4500 KC., 6.0 AMPS. AT 3000 KC., 3.0 AMPS. AT 1000 KC., 1.5 AMPS. AT 300 KC., 0.35 AMP. AT 100 KC., MICA	-48535-5	RE-13A-389K	2 21	661-59	93	7607280 P67	1	C53	
8	8		INSULATOR FOR C53	ISOLANTITE	-61029		23	7602239 P2	94	7810310 P42	4	C53, S6	
1	1	C54	CAPACITOR - P.A. TANK	0.00015 MFD. ±5%, 20,000 VOLTS TEST EFF. 10,000 V. WORKING #(5,3,8,2,5,1,3), MICA	-48534-5	RE13A389K	2 17 21	316-51	95	7607280 P68	1	C54	
3	3		INSULATOR FOR C54	ISOLANTITE			23	7806601 P1	96	7810310 P97	0	C54 & ANT.	
1	1	C55	CAPACITOR - P.A. GRID COUPLING	0.000075 MFD. MAX. 0.000015 MFD. MIN. (0.07" SPACING) VARIABLE AIR			4	NP-75-DS	97	7607403 P4	0	C55	
2	2		STRIP FOR C55	ISOLANTITE			4		98		0		
X	X		INSULATOR FOR C55	SAME AS ITEM 39	-61028				99	7408805 P2			
1	1	C56	CAPACITOR - M.O. TANK	0.000375 MFD. ±2%, 5000 V. TEST EFF. #(4,2,5,1,0,0,5) 2500 V. WORKING MICA, CONST. CAP. AT 60°	-48481 D2	RE13A389K	2 17	656-6H 1550-N-250	100	7607280 P70	1	C56	

PARTS AND SPARE PARTS FOR TBK-20 RADIO TRANSMITTING EQUIPMENT										SPARE PARTS			
TOTAL USED PER EQUIP		SYMBOL DESIG.	FUNCTION	DESCRIPTION	NAVY TYPE NUMBER	NAVY SPEC. NUMBER	MFR.	MFR. DESIG.	CONTRACTOR'S ITEM NO.	CONTRACTOR'S DRAWING NUMBER	EQUIP		ALL SYMBOL DESIGNATIONS INVOLVED
115 DC	230 DC										BOX NUMBER	QUANTITY	
1	1	C57	CAPACITOR - P.A. GRID	0.000025 MFD. ±5%, 10,000 V. TEST EFF., 5000 V. WORKING #(3,1.0,0.3,0.5), MICA	-48423-5	RE-13A389K	2 17		101	7607280 P71	1		C57
2	2	C58	CAPACITOR - H.V. FILTER	4 MFD., ±10%, 3000 V.D.C. WKG., PAPER	-48685-10	RE-13A488C	1	TYPE FL	102	7607280 P72	1		C58, C65
		C59	NOT USED										
1	1	C60	CAPACITOR - THERMOSTAT RELAY SPARK SUPPRESSOR	0.5 MFD., ±10%, 400 V.D.C. WKG., PAPER	-48205A-10	SEE NOTE	2	DH-4050A	103	7607281 P74	1		C60
1	1		SUPPORT FOR C60	MICARTA ANG. 2 1/2 OF 1 5/8 X 5/8 X 1/8 TK.			1	7705763 P4	104	7606524 P5	0		
1	1	C61	CAPACITOR - CALIBRATION RESET	0.000002 MFD., VARIABLE AIR			1		105	7405440 G1	0		C61
1	1		EXTENSION FOR C61	MHCARTA 3 3/16 OF 3/4 O.D. X 3/8 I.D.			1		106		0		
2	2		INSULATOR - STAND-OFF FOR C61	ISOLANTITE 1 1/4 X 23/32 SQ.	-61032	RE-61A-209 RE-13A-317	23	7705360 P11	107	7405440 P10	1		
3	3		INSULATOR - STANDOFF FOR C61	ISOLANTITE 2 OF 1/2 SQ	-61107	RE-61A-209 RE-13A-317	23	7705360 P14	108	7405440 P12	2		
1	1	C62	CAPACITOR - COMPENSATING	0.00001 MFD., VARIABLE AIR PART OF T-3					109	7810264 G/3	0		C62
X	X	C63	CAPACITOR - BLOWER MOTOR BY-PASS	SAME AS C45	-48686-10				110				
X	X	C64	CAPACITOR - BLOWER MOTOR BY-PASS	SAME AS C45	-48686-10				111				
X	X	C65	CAPACITOR H.V. FILTER	SAME AS C58	-48685-10				112	7607281 P79			
1	1	C66	CAPACITOR H.V. R.F. BY-PASS	0.0001 MFD., ±5%, 7500 V.D.C. TEST EFF. #(1.3,.5,.3,.1), MICA	-481214-5	RE48AA131	2 17	321-6P 1550-318	113	7607281 P80	1		C66
1	1	C67	CAPACITOR - P.A. SCREEN BY-PASS	0.0001 MFD., ±10%, 5000 V.D.C. TEST, 2500 V.D.C. WORKING, MICA.	-48001-10	RE48AA112N			114	7607281 P81	1		C67

8-9

PARTS AND SPARE PARTS FOR TBK-20 RADIO TRANSMITTING EQUIPMENT										SPARE PARTS		
TOTAL USED PER EQUIP	SYMBOL DESIG.	FUNCTION	DESCRIPTION	NAVY TYPE NUMBER	NAVY SPEC. NUMBER	MFR.	MFR. DESIG.	CONTRACTOR'S ITEM NO.	CONTRACTOR'S DRAWING NUMBER	EQUIP		ALL SYMBOL DESIGNATIONS INVOLVED
										BOX NUMBER	QUANTITY	
115 DC	230 DC											
1	1	C68	CAPACITOR - FREQ. METER R.F. COUPLING	SPECIAL ADJUSTABLE BAND ON CERAMIC INSULATORS		RE48AA112N		115	7407390 G1		0	C68
1	1		INSULATOR FOR C68	ISOLANTITE 1 1/2 LG. X 3/4 DIA.	-61068		23	7602239 P23	116	7407390 P5	1	
1	1		STUD FOR C68	BRASS 3/4 LG. SPECIAL			1	7400705 P6	117	7407390 P11	0	
X	X		CONNECTOR FOR C68	SAME AS ITEM 40					113			
6	6	E211	H.V. BRUSH	USED ON 1000 V. GEN.			1	S#1133015	119	31J-907-P55	30	E-211, E-221
2	2	E212	L.V. BRUSH	USED ON 275 V. GEN.			1	S#1133016	120	31-J-907 P56	10	E212
2	2	E213	SHUNT & SERIES COILS	USED ON 1000 & 275 V. GENS.			1	L-372453	121	31-J-907 P16 P17 & P18	2	E213
8	8	E214	BRUSH HOLDER				1	S#1124399	122	33-J-176 P122	8	E214, E224
8	8	E214A	HOLDER SPRING				1	S#848058	123	33-J-176 P42	12	E214A, E224A
8	8	E215A	INSULATOR FOR HOLDER	ISOLANTITE			23	#334	124	33-J-176 P43	8	E215A, E225A
16	16	E215B	WASHER FOR HOLDER	FIBRE			1	1-D-9054	125	33-J-176 P54	16	E215B, E-225B
1	1	E217	ARMATURE FOR G211	1000 V., 0.075A., 275V., 0.92A			1	2-B-2764	126	33-J-176 P120	1	E217
X	X	E221	BRUSHES	SAME AS E211					127	33-J-174 P43		
2	2	E222	SHUNT & SERIES COILS	USED ON 2000-3000 V. GEN.			1	L-372452	128	33-J-174 P57	2	E222
2	2	E223	COMPOUND COMM. COILS	USED ON 2000-3000 V. GEN.			1	L-372452	129	33-J-174 P59	2	E223
X	X	E224	BRUSH HOLDER	SAME AS E214					130	33-J-174 P112		
X	X	E224A	HOLDER SPRING	SAME AS E214A					131	33-J-174 P40		
X	X	E225A	INSULATOR FOR HOLDER	SAME AS E215A					132	33-J-174 P36		
X	X	E225B	WASHER FOR HOLDER	SAME AS E215B					133	33-J-174 P37		
1	1	E228	ARMATURE FOR G221	2000 V., 0.75A., 3000 V., 0.35A.			1	4-B-3824	134	33-J-174 P33	1	E228

6-9

PARTS AND SPARE PARTS FOR TBK-20 RADIO TRANSMITTING EQUIPMENT										SPARE PARTS		
TOTAL USED PER EQUIP.	SYMBOL DESIG.	FUNCTION	DESCRIPTION	NAVY TYPE NUMBER	NAVY SPEC. NUMBER	MFR.	MFR. DESIG.	CONTRACTOR'S ITEM NO.	CONTRACTOR'S DRAWING NUMBER	EQUIP.		ALL SYMBOL DESIGNATIONS INVOLVED
										BOX NUMBER	QUANTITY	
115 DC												
230 DC												
0	8	E241	BRUSHES FOR B241	D.C.		1	S#917122	135	33-J-178 P70	40	E241	
-	4	E242	BRUSHES FOR B241	A.C.		1	S#1153017	136	33-J-178 P42	20	E242, E272	
0	2	E243	FIELD COILS FOR B241	COMMUTATING		1	L-367854	137	33-J-178 P88	2	E243	
0	4	E244	FIELD COILS FOR B241	SHUNT		1	L-367854	138	33-J-178 P87	4	E244	
-	8	E245	HOLDERS FOR E241			1	S#271764	139	33-J-178 P122	8	E245, E283	
-	8	E245A	SPRING FOR E245			1	S#282836	140	33-J-178 P74	12	E245A, E275A	
-	2	E246	HOLDER FOR E242	RIGHT-HAND		1	S#1124417	141	33-J-178 P120	2	E246, E276	
-	2	E247	HOLDER FOR E242	LEFT-HAND		1	S#1124418	142	33-J-178 P121	2	E247, E277	
0	4	E247A	SPRING FOR E246 & E247			1	S#848058	143	31-J-907 P42	6	E247A	
-	4	E248	INSULATION FOR E245	MICARTA TUBE		1	S#285465	144	33-J-178 P65	4	E248, E278	
-	2	E249	INSULATION FOR E246 & E247	MICARTA TUBE		1	2-B-9099	145	33-J-178 P57	2	E249, E279	
0	1	E250	ARMATURE FOR B-241	230 VOLTS, 22 AMPS. D.C., 162 V. 3.3. AMPS. A.C.		1	2-B-9098	146	33-J-178 P117	1	E-250	
8	0	E271	BRUSHES FOR B271	D.C.		1	S#916415	147	33-J-180 P70	40	E271	
4	-	E272	BRUSHES FOR B271	A.C. SAME AS E242				148		20		
8	-	E275A	SPRING FOR E283	SAME AS E245A				149		12		
2	-	E276	HOLDER FOR E272	SAME AS E246				150		2		
2	-	E277	HOLDER FOR E272	SAME AS E247				151		2		
4	0	E277A	SPRING FOR E276 & E277			1	S#848058	152	31-J-907 P42	6	E277A	
4	-	E278	INSULATION FOR E283	SAME AS E248				153		4		
2	-	E279	INSULATION FOR E276 & E277	SAME AS E249				154		2		
2	0	E281	FIELD COILS FOR B271	COMMUTATING		1	L-367855	155	33-J-180 P88	2	E281	

PARTS AND SPARE PARTS FOR TBK-20 RADIO TRANSMITTING EQUIPMENT											SPARE PARTS	
TOTAL USED PER EQUIP	SYMBOL DESIG.	FUNCTION	DESCRIPTION	NAVY TYPE NUMBER	NAVY SPEC. NUMBER	MFR.	MFR. DESIG.	CONTRACTOR'S ITEM NO.	CONTRACTOR'S DRAWING NUMBER	EQUIP		ALL SYMBOL DESIGNATIONS INVOLVED
										BOX NUMBER	QUANTITY	
115 DC	230 DC											
4	0	E282	FIELD COILS FOR B271	SHUNT		1	L-367855	156	33-J-180 P87		4	E282
8	-	E283	HOLDER FOR E271	SAME AS E245				157			6	
1	0	E284	ARMATURE FOR B271	115 VOLTS, 4# AMPS. D.C., 81 VOLTS, 6.6 AMPS. A.C.		1	2-B-9174	158	33-J-180 P117		1	E284
2	2	F1	FUSE - CONTROL CIRCUIT	6 AMPS., 250 V., NON-RENEWABLE	17-F-2G	22	CAT#25116	159	7607281 P89		20	F1,F2
1	1		HOLDER FOR F1 & F2	PORCELAIN FOR 2 FUSES		6	7605881 P4	160	7607287 P11		1	F1,F2
X	X	F2	FUSE - CONTROL CIRCUIT	SAME AS F1	17F-2G			161	7607281 P91			
1	1	F211	FUSE	0.25A., 5000 V.		5	#3022C	162	33-J-176 P66		20	F211
1	1	F212	FUSE	3A., 250V.		1	#7051	163	33-J-176 P84		10	F212
1	1	F221	FUSE	1A., 5000 V.		5	#3025C	164	33-J-174 P92		20	F221
1	1	F222	FUSE	2A., 5000 V.		5	#3026C	165	33-J-174 P93		10	F222
1	-	F841	CONTROL FUSE	10 AMP., 250 VOLTS			S#37160	166	45-J-406 P10		10	F-841, F-851
-	1	F851	CONTROL FUSE	SAME AS F841				167			10	
1	1	G211	L.V. GENERATOR		-21679	1		168	31-J-907 P55		0	G211
1	1	G221	H.V. GENERATOR		-21680	1		169			0	G221
2	2	1-1A	INDICATOR LAMP BIAS	LIGHT RECEPTACLE		1	SEE NOTE	170	7607281 P102		1	1-1A, 1-4A
5	5	1-1B	INDICATOR LAMP	LIGHT BULB 18V., 0.11 AMP.	TS-51	1	S#549474	171	7607281 P103		10	1-1B, 1-2B, 1-3B, 1-4B, 1-5B, 1-6B
1	1	1-1C	INDICATOR LAMP	LENS GREEN		1	S#549469	172	7607281 P104		1	1-1C
3	-	1-2A	INDICATOR LAMP M.G.	LIGHT RECEPTACLE, 1200 OHMS, WITH MTC.		1	SEE NOTE	173	7607281 P105		1	1-2A, 1-3A, 1-5A
X	-	1-2B	INDICATOR LAMP	LIGHT BULB - SAME AS 1-a	TS-51			174	7607281 P106			
2	-	1-2C	INDICATOR LAMP	LENS - RED		1	S#549468	175	7607281 P107		1	1-2C, 1-3C, 1-6C

PARTS AND SPARE PARTS FOR TBK-20 RADIO TRANSMITTING EQUIPMENT

SPARE PARTS

TOTAL USED PER EQUIP	SYMBOL DESIG.	FUNCTION	DESCRIPTION	NAVY TYPE NUMBER	NAVY SPEC. NUMBER	MFR.	MFR. DESIG.	CONTRACTOR'S ITEM NO.	CONTRACTOR'S DRAWING NUMBER	EQUIP		ALL SYMBOL DESIGNATIONS INVOLVED
										BOX NUMBER	QUANTITY	
115 DC												
230 DC												
X 2	1-3A	INDICATOR LAMP	RECEPTACLE - SAME AS 1-2A					176	7607281 P108		1	
X X	1-3B	INDICATOR LAMP	LIGHT BULB - SAME AS 1-1B	TS-51				177	7607281 P109			
X 2	1-3C	INDICATOR LAMP	LENS RED - SAME AS 1-2C					178	7607281 P110		1	
X X	1-4A	INDICATOR LAMP	RECEPTACLE - SAME AS 1-1A					179	7607281 P111			
X X	1-4B	INDICATOR LAMP	LIGHT BULB - SAME AS 1-1B	TS-51				180	7607281 P112			
1 1	1-4C	INDICATOR LAMP	LENS - CLEAR			1	S#549470	181	7607281 P113		1	1-4C
X X	1-5A	INDICATOR LAMP	RECEPTACLE - SAME AS 1-2A					182	7507281 P114			
X X	1-5B	INDICATOR LAMP	LIGHT BULB- SAME AS 1-1B	TS-51				183	7607281 P115			
1 1	1-5C	INDICATOR LAMP	LENS - AMBER			1	S#549472	184	7607281 P116		1	1-5C
0 1	1-6A	INDICATOR LAMP	RECEPTACLE			1	S#867325B	185	7810310 P332		1	1-6A
1 X	1-6B	INDICATOR LAMP	LIGHT BULB - SAME AS 1-1B	TS-51				186	7810310 P333			
1 X	1-6C	INDICATOR LAMP	LENS - SAME AS 1-2C					187	7810310 P334			
1 1	J1	JACK - FREQUENCY METER	JACK AND CUP ASSEMBLY (INCLUDES -49021) JACK ONLY, TWO CIRCUITS NORMALLY CLOSED	-49110 -49021	RE-49AA147A RE-13A481B	8	SEE NOTE	188	7607281 P124		1	J1
1 1	K1	RELAY - KEYING	D.P.S.T., PLUS S.P.D.T., TWO BREAKS PER CIRCUIT, NORMALLY THREE CIRCUITS OPEN & ONE CIRCUIT CLOSED.	-29169		1		189	T7604741 G12		1	K1
1 1		CONTACT BOARD FOR K1	MICARTA 3 1/4 X 1 15/16 OF 3/16 TK.			1	7808426 P1	190	7705079 P2		0	K1
6 6		CONTACT FOR K1 MTG.				27	7805282 P3	191	7705079 P4		2	K1
2 2		BLOCK FOR K1 MTG	MICARTA 2 1/8 X 2 OF 3/4 TK.			1	7705079 P10	192	7810310 P24		0	K1
1 1	K2	RELAY - COMPENSATOR	S.P.D.T. SINGLE BREAK PER CIRCUIT 0.005 AMP. AT 50 VOLTS D.C. NORMALLY OPERATES AT 75 VOLTS D.C. ±20% WITH 5000 OHMS SERIES RESISTOR.	-29058		7	SEE NOTE	193	7607281 P139		0	K2

PARTS AND SPARE PARTS FOR TBK-20 RADIO TRANSMITTING EQUIPMENT										SPARE PARTS		
TOTAL USED PER EQUIP	SYMBOL DESIG.	FUNCTION	DESCRIPTION	NAVY TYPE NUMBER	NAVY SPEC. NUMBER	MFR.	MFR. DESIG.	CONTRACTOR'S ITEM NO.	CONTRACTOR'S DRAWING NUMBER	EQUIP		ALL SYMBOL DESIGNATIONS INVOLVED
										BOX NUMBER	QUANTITY	
115 D.C.	230 D.C.											
1	1	K2A	COIL FOR K2			7	TYPE "V"	194	7607281 P140		1	K2A
2	2	K2B	CONTACT FOR K2			7	#2964	195	7607281 P141		1	K2B, K20B
2	2	K2B	CONTACT FOR K2			7	#2071	196	7607281 P142		1	K2B, K20B
1	1	K4	RELAY-MAIN STARTING	-29064		1	S#1264017A	197	9-A-3882 LINE 2		0	K4
1	1	K4A	COIL FOR K4			1	S#897943	198			1	K4A
5	5	K4B	CONTACT FOR K4			1	S#897644	199			3	K4B, K4C, K4D, K9B, K9C
5	5	K4B	CONTACT FOR K4			1	S#897622	200			3	K4B, K4C, K4D, K9B, K9C
X	X	K4C	CONTACT FOR K4					201				
X	X	K4C	CONTACT FOR K4					202				
X	X	K4D	CONTACT FOR K4					203				
X	X	K4D	CONTACT FOR K4					204				
1	1	K5	RELAY - H.V. OVERLOAD	-29195		1	S#1164031 TYPE "MN"	205	7710114 P3		0	K5
1	1	K5A	CONTACT FOR K5			4	S#1164028	206	7607282 P155		1	K-5A
2	2	K5B	CONTACT FOR K5			1	S#1202083	207	7607282 P156		1	K5B, K7B
2	2	K5C	CONTACT FOR K5			1	S#1202082	208	7607282 P157		1	K5B, K7B
2	2	K5D	BASE FOR K5			1		209			0	K5, K7
2	2	K5E	CONTACT FOR K5			1		210			0	K5, K7
		K6	NOT USED									

PARTS AND SPARE PARTS FOR TBK-20 RADIO TRANSMITTING EQUIPMENT										SPARE PARTS		
TOTAL USED PER EQUIP	SYMBOL DESIG.	FUNCTION	DESCRIPTION	NAVY TYPE NUMBER	NAVY SPEC. NUMBER	MFR.	MFR. DESIG.	CONTRACTOR'S ITEM NO.	CONTRACTOR'S DRAWING NUMBER	EQUIP		ALL SYMBOL DESIGNATIONS INVOLVED
										BOX NUMBER	QUANTITY	
115 DC												
230 DC												
1	1	K7	RELAY - L.V. OVERLOAD	-29196		1	S#1164029	211	7710114 P1	0		K7
1	1	K7A	COIL FOR K7			1	S#1164026	212	7607282 P159	1		K7A
X	X	K7B	CONTACT FOR K7					213				
X	X	K7B	CONTACT FOR K7					214				
X	X		BASE FOR K7					215				
X	X		INSULATOR FOR K7					216				
1	1		PANEL FOR C60 & R49			1	7705763 P2	217	7606529 P2	0		C60, R49
1	1		TERM. BD. FOR C60 & R49			1	7606529 P3	218	7606529 P3	0		C60, R49
		K8	NOT USED									
1	1	K9	RELAY - FIELD CIRCUIT	-29062		1	S#1264016A	219	9A-3882 LINE 1	0		K9
1	1	K9A	COIL FOR K9			4	S#875799	220		1		K9A
X	X	K9B	CONTACT FOR K9					221				
X	X	K9B	CONTACT FOR K9					222				
X	X	K9C	CONTACT FOR K9					223				
X	X	K9C	CONTACT FOR K9					224				
1	1	K20	RELAY - THERMOSTAT			7	7609921 P1	225	7609529 P26	0		K20
1	1	K20A	COIL FOR K20			7	COIL "1"	226		1		K20A
X	X	K20B	CONTACT FOR K20					227				
X	X	K20B	CONTACT FOR K20					228				

71-9

PARTS AND SPARE PARTS FOR TBK-20 RADIO TRANSMITTING EQUIPMENT										SPARE PARTS		
TOTAL USED PER EQUIP	SYMBOL DESIG.	FUNCTION	DESCRIPTION	NAVY TYPE NUMBER	NAVY SPEC. NUMBER	MFR.	MFR. DESIG.	CONTRACTOR'S NO.	CONTRACTOR'S DRAWING NUMBER	EQUIP		ALL SYMBOL DESIGNATIONS INVOLVED
										BOX NUMBER	QUANTITY	
115 DC	230 DC											
X	X		PANEL FOR K20					229				
X	X		TERM. BD. FOR K20, C60 R56, R57, & R58					230				
1	-	K841	CONTACTOR					231	45-J-406-P1	0		K-841
1	0	K841A	COIL				S#1303531	232	37-J-922 P5	1		K-841A
2	-	K841B	MAIN CONTACT				S#1303972	233	37-J-922 P1	2		K-841B, K-841C
2	-	K841B	MAIN CONTACT				S#1303971	234	37-J-922 P2	2		K-841B, K-841C
X	-	K841C	MAIN CONTACT					235				
X	-	K841C	MAIN CONTACT					236				
2	-	K841D	CONTACT - STATIONARY				S#1308214	237	37-J-922 P9	2		K-841D
1	-	K841D	CONTACT - MOVABLE				S#1308317	238	37-J-922 P10	1		K-841D
2	-	K841E	CONTACT - STATIONARY				S#1308250	239	37-J-922 P6	2		K-841E
1	-	K841E	CONTACT - MOVABLE				S#1308251	240	37-J-922 P7	1		K-841E
2	-	K841F	CONTACT - STATIONARY				S#1308181	241	37-J-922 P12	2		K-841F
1	-	K841F	CONTACT - MOVABLE				S#1257419	242	37-J-922 P13	1		K-841F
2	-		INSULATION FOR K-841					243	37-J-922 P16	0		
2	-	K842	RELAY					244		0		K-842, K-843
2	0	K842A	COIL				S#1315390	245	37-J-890 P5	1		K-842A, K-843A
2	-	K842B	MAIN CONTACT				S#1308318	246	37-J-890-P2	2		K-842B, K-843B

51-9

PARTS AND SPARE PARTS FOR TBK-20 RADIO TRANSMITTING EQUIPMENT										SPARE PARTS		
TOTAL USED PER EQUIP	SYMBOL DESIG.	FUNCTION	DESCRIPTION	NAVY TYPE NUMBER	NAVY SPEC. NUMBER	MFR.	MFR. DESIG.	CONTRACTOR'S NO.	CONTRACTOR'S DRAWING NUMBER	EQUIP		ALL SYMBOL DESIGNATIONS INVOLVED
										BOX NUMBER	QUANTITY	
115 DC	230 DC								CONTRACTOR'S ITEM			
2	- K842B	MAIN CONTACT	MOVABLE FOR K842				S#1308319	247	37-J-890 P1		2	K-842B, K-843B
4	- K842C	CONTACT - STATIONARY	FOR RELAY K842				S#1258707	248	37-J-890 P6		4	K-842C, K-843C
2	- K842C	CONTACT - MOVABLE	FOR RELAY K842				S#1257419	249	37-J-890 P7		2	K-842C, K-843C
4	- K842D	CONTACT - STATIONARY	FOR RELAY K842				S#1258708	250	37-J-890 P9		4	K-842D, K-843D
2	- K842D	CONTACT - MOVABLE	FOR RELAY K842				S#1312152	251	37-J-890 P10		2	K-842D, K-843D
2	- K842G	ARMATURE SPRING	FOR RELAY K842				S#1258963	252	37-J-890 P4		2	K-842G, K-843G
X	- K843	RELAY	SAME AS K842					253				
X	0 K843A	COIL	SAME AS K842A					254				
X	- K843B	MAIN CONTACT - STATIONARY	SAME AS K842B STA.					255				
X	- K843B	MAIN CONTACT - MOVABLE	SAME AS K842B MOV.					256				
X	- K843C	CONTACT - STATIONARY	SAME AS K842C STA.					257				
X	- K843C	CONTACT - MOVABLE	SAME AS K842C MOV.					258				
X	- K843D	CONTACT - STATIONARY	SAME AS K842D STA					259				
X	- K843D	CONTACT - MOVABLE	SAME AS K842D MOV.					260				
X	- K843G	ARMATURE SPRING	SAME AS K842G					261				
1	0 K844	OVERLOAD RELAY	MI HEATER					262			0	K-844
1	0 K844A	HEATER FOR K844	53 AMPS.				S#1265734	263	36-J-639 P22		1	K-844A
0	0 K844B	OVERLOAD RELAY - LESS HEATER	MI					264			1	K-844B
-	1 K851	CONTACTOR	SAME AS K841					265			0	K-851
0	1 K851A	COIL	TWO WINDINGS, ONE 3520 TURNS #33 EN. CU., 200 OHMS RESIS. - SECOND WINDINGS 26,700 TURNS #36 EN. CU. 4850 RESIS.				S#1303532	266	37-J-922 P5		1	K-851A

91-9

PARTS AND SPARE PARTS FOR TBK-20 RADIO TRANSMITTING EQUIPMENT											SPARE PARTS	
TOTAL USED PER EQUIP	SYMBOL DESIG.	FUNCTION	DESCRIPTION	NAVY TYPE NUMBER	NAVY SPEC. NUMBER	MFR.	MFR. DESIG.	CONTRACTOR'S ITEM NO.	CONTRACTOR'S DRAWING NUMBER	EQUIP		ALL SYMBOL DESIGNATIONS INVOLVED
										BOX NUMBER	QUANTITY	
115 DC	230 DC											
- 2	K851B	MAIN CONTACT - STATIONARY	SAME AS K841B STA.					267			2	K-851B, K-851C
- 2	K851B	MAIN CONTACT - MOVABLE	SAME AS K841B MOV.					268			2	K-851B, K-851C
- X	K851C	MAIN CONTACT - STATIONARY	SAME AS K841B STA.					269				
- X	K851C	MAIN CONTACT - MOVABLE	SAME AS K841B MOV.					270				
- 2	K851D	CONTACT - STATIONARY	SAME AS K841D STA.					271			2	K-851D
- 1	K851D	CONTACT - MOVABLE	SAME AS K841D MOV.					272			1	K-851D
- 2	K851E	CONTACT - STATIONARY	SAME AS K841E STA.					273			2	K-851E
- 1	K851E	CONTACT - MOVABLE	SAME AS K841E MOV.					274			1	K-851E
- 2	K851F	CONTACT - STATIONARY	SAME AS K841F STA.					275			2	K-851F
- 1	K851F	CONTACT - MOVABLE	SAME AS K841F MOV.					276			1	K-851F
- 2		INSULATION FOR K-851	ARC SHIELD - SAME AS ITEM #243					277			0	
- 2	K852	RELAY	SAME AS K842					278			0	K-852, K-853
0 2	K852A	COIL	TWO WINDINGS - ONE 8,000 TURNS #34 EN.CU. 980 OHMS RESIS.- SECOND WINDING 2100 TURNS #36 EN.CU. 500 OHMS RESIS.				S#1315391	279	37-J-890 P5		1	K-852A, K-853A
- 2	K852B	MAIN CONTACT - STATIONARY	SAME AS K842B STA.					280			2	K-852B, K-853B
- 2	K852B	MAIN CONTACT - MOVABLE	SAME AS K842 B MOV.					281			2	K-852B, K-853B
- 4	K852C	CONTACT - STATIONARY	SAME AS K842 C STA.					282			4	K-852C, K-853C
- 2	K852C	CONTACT - MOVABLE	SAME AS K842 C MOV.					283			2	K-852C, K-853C
- 4	K852D	CONTACT - STATIONARY	SAME AS K842 D STA.					284			4	K-852D, K-853D
- 2	K852D	CONTACT - MOVABLE	SAME AS K842 D MOV.					285			2	K-852D, K-853D
- 2	K852G	ARMATURE SPRING	SAME AS K842 G					286			2	K-852G, K-853G
- X	K853	RELAY	SAME AS K842					287				

21-9

PARTS AND SPARE PARTS FOR TBK-20 RADIO TRANSMITTING EQUIPMENT										SPARE PARTS		
TOTAL USED PER EQUIP	SYMBOL DESIG.	FUNCTION	DESCRIPTION	NAVY TYPE NUMBER	NAVY SPEC. NUMBER	MFR.	MFR. DESIG.	CONTRACTOR'S ITEM NO.	CONTRACTOR'S DRAWING NUMBER	EQUIP		ALL SYMBOL DESIGNATIONS INVOLVED
										BOX NUMBER	QUANTITY	
115 DC												
230 DC												
0	X	K853A	COIL					288				
-	X	K853B	MAIN CONTACT - STATIONARY					289				
-	X	K853B	MAIN CONTACT - MOVABLE					290				
-	X	K853C	CONTACT - STATIONARY					291				
-	X	K853C	CONTACT - MOVABLE					292				
-	X	K853D	CONTACT - STATIONARY					293				
-	X	K853D	CONTACT - MOVABLE					294				
-	X	K853G	ARMATURE SPRING					295				
0	1	K854	OVERLOAD RELAY					296			0	K-854
0	1	K854A	HEATER FOR K854				S#1265727	297	36-J-639 P22		1	K-854A
0	0	K854B	OVERLOAD RELAY - LESS HEATER					298			1	K-854B
1	1	L1	COIL - M.O. TANK - INCLUDES SIA, B, C1, C2, C3, C56 & C61					299	7810311 G1		0	L1, SIA, SIB, C1, C2, C3, C56, C61
0	0		COIL - SPARE FOR L1					300	7810311 G2		0	L1
6	6		INSULATOR FOR L1		-61118		23	7806537 P1	301	7810311 P9	3	L1
1	1		END FOR L1 (FRONT)				1	7405446 P2	302	7810311 P55	0	L1
1	1		END FOR L1 (REAR)				1	7706375 P3	303	7810311 P4	0	L1
1	1		CONTACT FOR L1 (SLIDING)				1	7405699 P3	304	7604992 P18	2	L1

81-9

PARTS AND SPARE PARTS FOR TBK-20 RADIO TRANSMITTING EQUIPMENT											SPARE PARTS		
TOTAL USED PER EQUIP.		SYMBOL DESIG.	FUNCTION	DESCRIPTION	NAVY TYPE NUMBER	NAVY SPEC. NUMBER	MFR.	MFR. DESIG.	CONTRACTOR'S ITEM NO.	CONTRACTOR'S DRAWING NUMBER	EQUIP.		ALL SYMBOL DESIGNATIONS INVOLVED
115 DC	230 DC										BOX NUMBER	QUANTITY	
1	1	L2	COIL - M.O. FIL CHOKE	TWO COACIAL WINDINGS, BOTTOM WINDING 50 TURNS, TOP WINDING 48-1/2 TURNS 3.5 AMPS A.C. OR D.C.			1		305	7707507 G5		0	L2
0	0		COIL - SPARE FOR L2				1	7705707 G1	306	7607282 P193		0	L2
1	1		COIL FORM FOR L2	MICARTA TUBE 5 5/16 OF 3 O.D. X 2 5/8 I.D.			1	7705707 P3	307			0	L2
1	1	L3	16-5/8 TURNS OF #10 TINNED COPPER WIRE, 5 AMPS. R.F., 10 MICROHENRIES				1		308	7705659 G5		0	L3
1	1		COIL FORM FOR L3	MICARTA TUBE 4 5/8 OF 3 O.D. X 2 3/4 I.D.			1	7404909 P1	309	7705659 P2		0	L3
6	6		INSULATOR FOR L3	ISOLANTITE 3 3/8 X 1/2 X 1/2	-61130		23	7602239 P13	310	7705659 P4		3	L3
1	1	L4	COIL - M.O. PLATE CHOKE	INDUCTANCE 4 MILLIHENRIES, D.C. RESISTANCE 10 OHMS, 500 MILLIAMPS D.C.			9	TYPE R-152	311	7607282 P197		1	L4
3	3	L5	COIL - 1ST INT. PLATE CHOKE	125 TURNS, INDUCTANCE 0.35 MILLIHENRIES ±5%, D.C. RESISTANCE 1.35 OHMS, TEST INDUCTANCE AT 1000 CYCLES 0.4 AMPS.			1		312	L-303463		1	L5, L17, L18
5	5		INSULATOR FOR L5	PRESTITE	-61423S		1	50-C-691 P1	313	7705781 P57		3	L5, L10, L15, L17, L18
5	5		INSULATOR FOR L5	MOLDARTA	-61422S		1	7408574 P1	314	7705781 P58		3	L5, L10, L15, L17, L18
2	2	L6	COIL - 1ST INT. GRID CHOKE	THREE SECTIONS, 20 TURNS EACH, 1/4" BETWEEN EACH SECTION, #26 S.C.C.E. WIRE, 200 MILLIAMPS D.C.			1		315	7405204 G2		0	L6, L8
0	0		COIL - SPARE FOR L6	LESS MOUNTING BRACKET			1	7405204 G5	316	7607282 P200		0	L6, L8
3	3		COIL FORM FOR L6	ISOLANTITE			23	7803570 P1	317	7405204 P2		0	L6, L8, L11
1	1	L7	COIL - 1ST INT. TANK	24 TURNS #14 TINNED COPPER WIRE, SPACE WOUND, 5 AMPS R.F.			1		318	7706592 G1		0	L7
1	1		COIL FORM FOR L7	ISOLANTITE			23	7705779 P2	319	7706592 P2		0	L7

61-9

PARTS AND SPARE PARTS FOR TBK-20 RADIO TRANSMITTING EQUIPMENT

SPARE PARTS

TOTAL USED PER EQUIP	SYMBOL DESIG.	FUNCTION	DESCRIPTION	NAVY TYPE NUMBER	NAVY SPEC. NUMBER	MFR.	MFR. DESIG.	CONTRACTOR'S ITEM NO.	CONTRACTOR'S DRAWING NUMBER	EQUIP		ALL SYMBOL DESIGNATIONS INVOLVED
										BOX NUMBER	QUANTITY	
115 DC												
230 DC												
X X	L8	COIL - 2ND INT. GRID CHOKE	SAME AS L6					320	7607282 P202			
0 0		COIL - SPARE FOR L8	SAME AS L6					321	7607282 P203			
X X		COIL FORM FOR L8	SAME AS ITEM 317					322				
1 1	L9	COIL - 2ND INT. TANK	ROTATING COIL, 22 MICROHENRIES, 14 TURNS 3/16" X 5/16" COPPER BAR, WOUND EDGEWISE 20 AMPS R.F.			1		323	7409127 G2	0		L9, S2D
3 3		ROTOR FOR L9				1	7609876 G1	324	7409127 P5	0		L9, L13, L14
18 18		INSULATOR FOR L9 ROTOR	ISOLANTITE	-61462		23	7409157 P1	325	7609876 P2	4		L9, L13, L14
3 3		END FOR L9 (FRONT)	MICALEX 8 X 7 3/4 X 3/8 TK.			1	7404913 P2	326	7409127 P23	0		L9, L13, L14
3 3		END FOR L9 (REAR)	MICALEX 8 X 7 3/4 X 3/8 TK.			1	7407465 P1	327	7409127 P50	0		L9, L13, L14
3 3		CONTACT FOR L9(SLIDING)	SPRING & SHOE			1	7808667 G1	328	7405547 P5	2		L9, L13, L14
3 3		SPRING FOR L9 CONTACT				1	7405680 P1	329	7405547 P6	3		L9, L13, L14
3 3		CONTACT BRUSH FOR L9	3 PIECES			1	7403735 G1	330	7405547 P7	2		L9, L13, L14
12 12		SPRING FOR L9				1	7409089 P1	331	7409127 P36	2		L9, L13, L14
12 12		SPRING FOR L9				1	7409089 P2	332	7409127 P37	2		L9, L13, L14
12 12		SPRING BRUSH FOR L9				1	7409089 P3	333	7409127 P38	2		L9, L13, L14
2 2	L10	COIL - 2ND INT. PLATE CHOKE	375 TURNS, BASKET WOUND; INDUCTANCE 4 MILLIHENRIES ±5%, D.C. RESISTANCE 5.15 OHMS, TEST INDUCTANCE AT 1000 CYCLE 0.4 AMP. D.C.			1		334	L-303481	1		L10, L15
X X		INSULATOR FOR L10	SAME AS ITEM 313	-61423S				335				
X X		INSULATOR FOR L10	SAME AS ITEM 314	-61422S				336				
1 1	L11	COIL P.A. GRID CHOKE	FOUR SECTION, 5-10-10-5 TURNS 1/4" BETWEEN SECTIONS, #30 D.C.C. CU. WIRE 100 MILLIAMPS D.C.			1		337	7405204 G1	0		L11
0 0		COIL - SPARE FOR L11				1	7405204 G3	338	7607282 P207	0		L11

6-20

PARTS AND SPARE PARTS FOR TBK-20 RADIO TRANSMITTING EQUIPMENT										SPARE PARTS		
TOTAL USED PER EQUIP	SYMBOL DESIG.	FUNCTION	DESCRIPTION	NAVY TYPE NUMBER	NAVY SPEC. NUMBER	MFR.	MFR. DESIG.	CONTRACTOR'S ITEM NO.	CONTRACTOR'S DRAWING NUMBER	EQUIP		ALL SYMBOL DESIGNATIONS INVOLVED
										BOX NUMBER	QUANTITY	
X X			COIL FORM FOR L11					339				
1 1	L12		COIL - P.A. GRID CHOKE					340	L- 365782		1	L12
1 1			INSULATOR FOR L12					341	7604725 P4		1	L12
1 1	L13		COIL - ANT. TUNING					342	7409127 G1		0	L13
X X			ROTOR FOR L13					343				
X X			INSULATOR FOR L13 ROTOR					344				
X X			END FOR L13 (FRONT)					345				
X X			END FOR L13 (REAR)					346				
X X			CONTACT FOR L13 (SLIDING)					347				
X X			SPRING FOR L13 CONTACT					348				
X X			CONTACT BRUSH FOR L13					349				
X X			SPRING FOR L13					350				
X X			SPRING FOR L13					351				
X X			SPRING BRUSH FOR L13					352				
1 1	L14		COIL P.A. TANK					353	7409127 G3		0	L14, S2B
X X			ROTOR FOR L14					354				
X X			INSULATOR FOR L14 ROTOR					355				
X X			END FOR L14 (FRONT)					356				

PARTS AND SPARE PARTS FOR TBK-20 RADIO TRANSMITTING EQUIPMENT										SPARE PARTS		
TOTAL USED PER EQUIP	SYMBOL DESIG.	FUNCTION	DESCRIPTION	NAVY TYPE NUMBER	NAVY SPEC. NUMBER	MFR.	MFR. DESIG.	CONTRACTOR'S ITEM NO.	CONTRACTOR'S DRAWING NUMBER	EQUIP		ALL SYMBOL DESIGNATIONS INVOLVED
										BOX NUMBER	QUANTITY	
115 DC 230 DC												
X X		END FOR L14 (REAR)	SAME AS ITEM 327					357				
X X		CONTACT FOR L14 (SLIDING)	SAME AS ITEM 328					358				
X X		SPRING FOR L14 CONTACT	SAME AS ITEM 329					359				
X X		CONTACT BRUSH FOR L14	SAME AS ITEM 330					360				
X X		SPRING FOR L14	SAME AS ITEM 331					361				
X X		SPRING FOR L14	SAME AS ITEM 332					362				
X X		SPRING BRUSH FOR L14	SAME AS ITEM 333					363				
2 2		GEARS FOR L14	24 TEETH			25	7409127 P52	364	7409127 P52	0		L14
1 1		GEAR FOR L14	42 TEETH			25	7409127 P59	365	7409127 P59	0		L14
X X	L15	COIL - P A. PLATE CHOKE	SAME AS L10					366	7607282 P211			
X X		INSULATOR FOR L15	SAME AS ITEM 313	-61423S				367				
X X		INSULATOR FOR L15	SAME AS ITEM 314	-61422S				368				
1 1	L16	COIL - THUMP FILTER CHOKE	1600 TURNS, INDUC. AT 110 V., 60 CYCLE AND 0.5 AMP. D.C., 1 HENRY MIN. D.C. RESISTANCE 40.0 OHMS, MAX., 30 OHMS MIN. 60 CYCLE IMPEDANCE, -377 OHMS MIN. TEST AT 1500 V.A.C.	-3018S		1	7700950	369	7607282 P212	1		L16
X X	L17	COIL - FILTER CHOKE	SAME AS L5					370				
X X		INSULATOR FOR L17	SAME AS ITEM 313	-61423S				371				
X X		INSULATOR FOR L17	SAME AS ITEM 314	-61422S				372				
X X	L18	COIL - FILTER CHOKE	SAME AS L5					373				
X X		INSULATOR FOR L18	SAME AS ITEM 313	-61423S				374				
X X		INSULATOR FOR L18	SAME AS ITEM 314	-61422S				375				
1 1	L19	COIL - P.A. GRID	5 TURNS, #10 TINNED COPPER WIRE 7/8" INSIDE DIAMETER			1		376	7406169 G1	0		L19

6-22

PARTS AND SPARE PARTS FOR TBK-20 RADIO TRANSMITTING EQUIPMENT											SPARE PARTS	
TOTAL USED PER EQUIP	SYMBOL DESIG.	FUNCTION	DESCRIPTION	NAVY TYPE NUMBER	NAVY SPEC. NUMBER	MFR.	MFR. DESIG.	CONTRACTOR'S ITEM NO.	CONTRACTOR'S DRAWING NUMBER	EQUIP.		ALL SYMBOL DESIGNATIONS INVOLVED
										BOX NUMBER	QUANTITY	
115 D.C.	230 D.C.											
1	1	M1	METER-ANTENNA CURRENT	0 TO 15 AMPS., R.F. WITH ANTI-GLARE GLASS	-22035	17-1-12	1		377 7605997 P15		0	M1
1	1	M2	METER - P.A. PLATE CURRENT	0 TO 500 MA. D.C. WITH ANTI-GLARE GLASS	-22067	17-1-12	1		378 7605997 P1		0	M2
3	3	M3	METER - P.A. GRID CURRENT	0 TO 100 MA. D.C. WITH ANTI-GLARE GLASS	-22059	17-1-12	1		379 7605997 P16		0	M3, M5, M7
2	2	M4	METER - 2ND INT. PLATE CURRENT	0 TO 250 MA. D.C. WITH ANTI-GLARE GLASS	-22065	17-1-12	1		380 7605997 P4		0	M4, M6
X	X	M5	METER - 2ND INT. GRID CURRENT	SAME AS M3	-22059				381 7607283 P227			
X	X	M6	METER - 1ST INT. PLATE CURRENT	SAME AS M4	-22065				382 7607283 P228			
X	X	M7	METER - M.O. PLATE CURRENT	SAME AS M3	-22059				633 7607283 P229			
1	1	M8	METER - M.O. SCREEN CURRENT	0 TO 50 MA. D.C. WITH ANTI-GLARE GLASS	-22056	17-1-12	1		384 7605997 P17		0	M8
1	1	M9	METER - P.A. PLATE VOLTAGE	0 TO 3.5 K.V., D.C. 1000 OHMS PER VOLT WITH EXTERNAL MULTIPLIER -63775 WITH ANTI-GLARE GLASS	-22311	17-1-12	1		385 7605997 P26		0	M9
1	1	M9R	MULTIPLIER FOR M9		-63775				386 7607283 P232		1	M9R
1	1	M10	METER - P.A. TUBE LIFE	100,000 HOUR TOTAL TIME METER FOR 120 VOLTS, 60 CYCLE OPERATION, LOWEST CALIBRATION 1/10 HOUR CYCLO-METER TYPE WITH ANTI-GLARE GLASS	-22199C	17-1-12	1	S#1164055	387 7605997 P27		0	M10
1	1	M11	METER - FILAMENT VOLTAGE	0 TO 15 V.A.C. WITH ANTI-GLARE GLASS	-22080	17-1-12	1		388 7605997 P6		0	M11
1	1	M12	METER - BIAS VOLTAGE	0 TO 500 V.D.C. 1000 OHMS PER VOLT WITH INTERNAL MULTIPLIER WITH ANTI-GLARE GLASS	-22225	17-1-12	1		389 7605997 P21		0	M12
2	2	0-213	BEARING FOR G211				1	S#1196895	390 33-J-176 P103		2	0-213
3	3	0-214	BEARING PULLER PARTS FOR 0-213, 0-223, 0-241, 0-273	PLATES & BOLTS			1	97-C-683	391 33-J-185 P55		0	0-214, 0-224, 0-242, 0-274
4	4	0-223	BEARING FOR G221				1	S#1133077	392 33-J-174 P8		2	0-223, 0-241, 0-273

6-23

PARTS AND SPARE PARTS FOR TBK-20 RADIO TRANSMITTING EQUIPMENT										SPARE PARTS		
TOTAL USED PER EQUIP	SYMBOL DESIG.	FUNCTION	DESCRIPTION	NAVY TYPE NUMBER	NAVY SPEC. NUMBER	MFR.	MFR. DESIG.	CONTRACTOR'S ITEM NO.	CONTRACTOR'S DRAWING NUMBER	EQUIP		ALL SYMBOL DESIGNATIONS INVOLVED
										BOX NUMBER	QUANTITY	
115 DC	230 DC											
X	X	0-224	BEARING PULLER PARTS	SAME AS 0-214				393	33-J-174 P124'			
-	X	0-241	BEARINGS FOR B241	SAME AS 0-223				394				
-	X	0-242	BEARING PULLER PARTS	SAME AS 0-214				395				
X	-	0-273	BEARINGS FOR B271	SAME AS 0-223				396				
X	-	0-274	BEARING PULLER PARTS	SAME AS 0-214				397				
1	1	R1	RESISTOR - BIAS POT.	10,000 OHMS, STYLE "B", GRADE 1, CLASS 2, TAPPED 10 EQUAL VALUES	-63484-E	RE-13A372J	28	398	7607283 P242	1		R1
1	1	R2	RESISTOR - M.O. SCREEN	30,000 OHMS, STYLE "A", GRADE 1, CLASS 2	-63361-E	RE-13A-372J	28	399	7607283 P243	1		R2
1	1	R3	RESISTOR - M.O. PLATE	5000 OHMS, STYLE "A", GRADE 1, CLASS 2	-63212-E	RE-13A-372J	28	400	7607283 P244	1		R3
2	2	R4	RESISTOR - KEYING RELAY ARC SUPPRESSOR	5000 OHMS, STYLE "D", GRADE 1, CLASS 2	-63085-E	RE-13A-372J	28	401	7607283 P245	1		R4, R17
		R5	NOT USED									
1	1	R6	RESISTOR - FIL. RHEOSTAT	TWO 4" PLATES, 20 OHMS PER PLATE, EQUAL RESISTANCE STEPS, STAGGERED CONTACTS (SPECIAL)			10	402	7705853 P3	0		R6
0	1	R7	RESISTOR - BLOWER MOTOR SERIES	450 OHMS, STYLE D, GRADE 1, CLASS 2	-63069-E	RE-13A-372	28	403	7810310 P135	1		R7
5	5	R8	RESISTOR - 1ST. INT. SCREEN	5000 OHMS, STYLE B, GRADE 1, CLASS 2	-63149-E	RE-13A-372J	28	404	7607283 P249	3		R8, R10, R18, R23, R25
		R9	NOT USED									
X	X	R10	RESISTOR - 2ND INT. SCREEN	SAME AS R-8	-63149-E			405	7607283 P251			
1	1	R11	RESISTOR - LOW POWER FIL.	50 OHMS, STYLE B, GRADE 1, CLASS 2, TAPPED TEN EQUAL VALUES	-63224-E	RE-13A-372J	28	406	7607283 P252	1		R11

PARTS AND SPARE PARTS FOR TBK-20 RADIO TRANSMITTING EQUIPMENT

SPARE PARTS

TOTAL USED PER EQUIP	SYMBOL DESIG.	FUNCTION	DESCRIPTION	NAVY TYPE NUMBER	NAVY SPEC. NUMBER	MFR.	MFR. DESIG.	CONTRACTOR'S ITEM NO.	CONTRACTOR'S DRAWING NUMBER	EQUIP.		ALL SYMBOL DESIGNATIONS INVOLVED
										BOX NUMBER	QUANTITY	
115 DC												
230 DC												
1	1	R12	RESISTOR - P.A. SCREEN	1000 OHMS, STYLE B, GRADE 1, CLASS 2	-63141-E	RE-13A-372J	28	407	7607283 P253	1	1	R12
1	1	R13	RESISTOR - LOW VOLTAGE FIELD	1000 OHMS ±10%, STYLE B, GRADE 1, CLASS 2, TAPPED 10 EQUAL VALUES	-63257-E	RE-13A-372J	28	408	7607283 P254	1	1	R13
2	2	R14	RESISTOR - 2ND INT. TANK CAP. SHUNT	1 MEGOHM, ±5%, 2 WATTS COMPOSITION	-63426	RE-13A-372G	11	409	7607283 P255	1	1	R14, R20
1	1	R15	RESISTOR - H.V. POTENTIOMETER	3000 OHMS, STYLE A, GRADE 1, CLASS 2, TAPPED TEN EQUAL VALUES	-63236-E	RE-13A-372J	28	410	7607283 P256	1	1	R15
1	1	R16	RESISTOR - H.V. POTENTIOMETER	1500 OHMS, STYLE A, GRADE 1, CLASS 2, TAPPED TEN EQUAL VALUES	-63233-E	RE-13A-372J	28	411	7607283 P257	1	1	R16
X	X	R17	RESISTOR - COMP. RELAY SERIES	SAME AS R-4	-63085-E			412	7607283 P258			
X	X	R18	RESISTOR - TUNING	SAME AS R-8	-63149-E			413	7607283 P259			
3	3	R19	RESISTOR - BIAS POT.	500 OHMS, STYLE B, GRADE 1, CLASS 2, TAPPED TEN EQUAL VALUES	-63227-E	RE-13A-372J	28	414	7607283 P260	2	2	R19, R21, R28
X	X	R20	RESISTOR - P.A. TANK CAPACITY SHUNTING	SAME AS R14	-63426			415	7607283 P261			
X	X	R21	RESISTOR - BIAS POT.	SAME AS R19	-63227-E			416	7607283 P262			
1	1	R22	RESISTOR - P.A. GRID CHOKE SHUNTING	50,000 OHMS, STYLE D, GRADE 1, CLASS 2	-63097-E	RE-13A-372J	28	417	7607283 P263	1	1	R22
X	X	R23	RESISTOR - P A. GRID	SAME AS R8	-63149-E			418	7607283 P264			
1	1	R24	RESISTOR - 2ND INT. GRID	20,000 OHMS, STYLE B, GRADE 1, CLASS 2	-63159-E	RE-13A-372J	28	419	7607283 P265	1	1	R24
X	X	R25	RESISTOR - 1ST INT. GRID	SAME AS R8	-63149-E			420	7607283 P266			
1	1	R26	RESISTOR - M.O. HEATER	TWO SECTIONS - 118 OHMS/SEC.			1	421	7604990 G7	0	0	R26
		R27	NOT USED									
X	X	R28	RESISTOR - BIAS POT.	SAME AS R19	-63227-E			422	7607283 P269			
0	2	R29	RESISTOR - KEYING POT.	600 OHMS, GRADE 1, CLASS 2	-63071-E	RE-13A-372	28	423	7810310 P80	1	1	R29, R32
1	1	R30	RESISTOR - KEYING CIRCUIT SER	400 OHMS, STYLE D, GRADE 1, CLASS 2	-63067-E	RE-13A-372J	28	424	7607283 P271	1	1	R30

52-9

PARTS AND SPARE PARTS FOR TBK-20 RADIO TRANSMITTING EQUIPMENT										SPARE PARTS		
TOTAL USED PER EQUIP	SYMBOL DESIG.	FUNCTION	DESCRIPTION	NAVY TYPE NUMBER	NAVY SPEC. NUMBER	MFR.	MFR. DESIG.	CONTRACTOR'S ITEM NO.	CONTRACTOR'S DRAWING NUMBER	EQUIP		ALL SYMBOL DESIGNATIONS INVOLVED
										BOX NUMBER	QUANTITY	
115 DC												
230 DC												
	R31	NOT USED										
0 X	R32	RESISTOR - FIELD CONT. SERIES	SAME AS R29	-63071-E				425	7607283 P273			
1 1	R33	RESISTOR - GEN. FIELD PHEO.	THREE 4" PLATES, TOTAL RESISTANCE 3200 OHMS, TAPERED TAPS, RESISTANCE DECREASED WITH CLOCKWISE ROTATION STAGGERED CONTACTS 0.075 TO 0.62 AMP. (SPECIAL).			10	7707741 P1	426	7607283 P274	0		R33
0 1	R34	RESISTOR - STARTING CONT. SERIES	1150 OHMS, STYLE D, GRADE 1, CLASS 2	-63733-E	RE-13A-372	28		427	7607283 P275	1		R34
1 0	R35	RESISTOR - STARTING CONT. SERIES	375 OHMS STYLE D, GRADE 1, CLASS 2	-63732-E	RE-13A-372	28		428	7607283 P276	1		R35
0 1	R36	RESISTOR - KEYING POT.	1200 OHMS	-63077-E				429	7607283 P277	1		R36
	R37 TO R44	NOT USED										
4 4	R45	RESISTOR - H.V. POTENTIOMETER	1500 OHMS, STYLE A, GRADE 1, CLASS 2	-63204-E	RE-13A-372J	28		430	7607283 P281	2		R45, R46, R47, R48
X X	R46	RESISTOR - H.V. POTENTIOMETER	SAME AS R45	-63204-E				431	7607283 P282			
X X	R47	RESISTOR - H.V. POTENTIOMETER	SAME AS R45	-63204-E				432	7607283 P283			
X X	R48	RESISTOR - H.V. POTENTIOMETER	SAME AS R45	-63204-E				433	7607283 P284			
0 1	R49	RESISTOR - HEATER CONTROL	1 OHM, 3 WATTS, COMPOSITION	-63289	RE-13A-372G	12	TYPE D3-3	434	7607283 P285	1		R49
1 1	R50	RESISTOR - THERMOSTAT SPARK SUPPRESSOR	30,000 OHMS, 1 WATT, COMPOSITION	-63288	RE-13A-372G	12	TYPE D1-1	435	7607283 P286	1		R50
	R51 TO R55	NOT USED										
1 0	R56	RESISTOR - THERMOSTAT RELAY	2000 OHMS, STYLE D, GRADE 1, CLASS 2	-63553-E	RE-13A-372	28		436	7607284 P292	1		R56
0 1	R57	RESISTOR - THERMOSTAT RELAY	8000 OHMS, STYLE D, GRADE 1, CLASS 2	-63506-E	RE-13A-372	28		437	7607284 P293	1		R57

6-26

PARTS AND SPARE PARTS FOR TBK-20 RADIO TRANSMITTING EQUIPMENT										SPARE PARTS		
TOTAL USED PER EQUIP	SYMBOL DESIG.	FUNCTION	DESCRIPTION	NAVY TYPE NUMBER	NAVY SPEC. NUMBER	MFR.	MFR. DESIG.	CONTRACTOR'S ITEM NO.	CONTRACTOR'S DRAWING NUMBER	EQUIP		ALL SYMBOL DESIGNATIONS INVOLVED
										BOX NUMBER	QUANTITY	
115 DC	230 DC											
1	0	R58	RESISTOR - HEATER CONTROL			1	7705763 G4	438	7607284 P294	1	R58	
1	0	R841	STARTING RESISTOR			1	S#1312904	439	45-J-406-P9	1	R-841	
		R842	NOT USED									
1	-	R843	POTENTIOMETER			1	S#884241	440	45-J-406 P8	1	R-843	
		R844 TO R850	NOT USED									
0	1	R851	STARTING RESISTOR			1	S#1312911	441		1	R-851	
		R852	NOT USED									
-	1	R853	POTENTIOMETER	SAME AS R843				442		1	R-853	
1	1	S1A	SWITCH - M.O. RANGE	PART OF L1		1		443	7607284 P299	0	S1A	
16	16		CONTACT FOR S1A & S1B			1	7705733 P8	444	7810311 P40	4	S1A, S1B	
2	2		ARM FOR S1A & S1B			1	7705733 G2	445	7810311 P41	2	S1A, S1B	
1	1		PLATE FOR S1A	MICALEX 4 X 3 3/8 X 1/4 TK		1	7706375 P2	446	7810311 P31	0	S1A	
1	1	S1B	SWITCH - M.O. RANGE	PART OF L1		1		447	7607284 P300	0	S1B	
X	X		CONTACT FOR S1B	SAME AS ITEM 444				448				
X	X		ARM FOR S1B	SAME AS ITEM 445				449				
1	1	S1C	INTERLOCK - M.O. RANGE	S.P.S.T. NORMALLY CLOSED		1		450	7607284 P301	1	S1C	
1	1	S2A	INTERLOCK - P.A. RANGE	S.P.S.T., ONE BREAK PER CIRCUIT, 0.2 AMP., 220 V.D.C., INTERLOCK TYPE		1		451	7705078 G2	1	S2A	
1	1	S2B	SWITCH - P.A. RANGE	MOUNTED ON L14		1	7708170 G1	452	7409127 P60	1	S2B	
1	1	S2C	SWITCH - P.A. RANGE GRID	S.P.S.T., ONE BREAK PER CIRCUIT, KNIFE SWITCH TYPE		1		453	7406186 G6	1	S2C	

6-2-

PARTS AND SPARE PARTS FOR TBK-20 RADIO TRANSMITTING EQUIPMENT											SPARE PARTS		
TOTAL USED PER EQUIP		SYMBOL DESIG.	FUNCTION	DESCRIPTION	NAVY TYPE NUMBER	NAVY SPEC. NUMBER	MFR.	MFR. DESIG.	CONTRACTOR'S NO.	CONTRACTOR'S DRAWING NUMBER	EQUIP		ALL SYMBOL DESIGNATIONS INVOLVED
115 DC	230 DC										BOX NUMBER	QUANTITY	
1	1		PLATE FOR S2C	MICALEX 3 X 2 1/4 OF 1/4 TK.			1	7406186 P16	454	7406186 P16	1		S2C
1	1	S2D	SWITCH - 2ND INT. RANGE	MOUNTED ON L9			1	7708170 G2	455	7409127 P46	1		S2D
1	1	S2E	SWITCH - 1ST INT. RANGE	S.P.S.T., ONE BREAK PER CIRCUIT, KNIFE SWITCH TYPE			1		456	7605006 G9	1		S2E
2	2		INSULATOR FOR S2E	ISOLANTITE 1 X 1/2 DIA.	-61232		23	7602239 P64	457	7605006 P11	1		S2E
3	3	S3A	SWITCH - FIL. COMPENSATION	S.P., TWO POSITIONS, ONE BREAK PER CIRCUIT, 10 AMPS., 125 VOLTS, TOGGLE TYPE	-24095A		13		458	7706780 P1	1		S3A, S3B, S3C
X	X	S3B	SWITCH - P.A. FILAMENT	SAME AS S3A	-24095A				459	7607284 P308			
X	X	S3C	SWITCH - TUBE LIFE METER	SAME AS S3A	-24095A				460	7607284 P309			
1	1	S4A	SWITCH - P.A. GRID (HI-LO)	D.P.D.T., ONE BREAK PER CIRCUIT, 10 AMPS. R.F., 3000 VOLTS, ROTARY TYPE			1		461	7613489 G1	0		S4A, S4B
X	X	S4B	HIGH-LOW POWER INTERMEDIATE AMPLIFIER ANTENNA TRANSFER SWITCH	PART OF S4A					462	7607284 P311	0		
1	1		PLATE FOR S4A & S4B	MICARTA 7 1/2 X 3 3/16 X 1/4 TK.			1	7415416 G2	463	7713515 P5	0		S4A, S4B
1	1		INSULATOR FOR S4A & S4B	MICALEX 2 3/4 X 1 3/4 X 1/4 TK.			1	7806466 P1	464	7713488 P4	0		S4A, S4B
2	2		INSULATOR FOR S4A & S4B	ISOLANTITE 1 LG X 1 3/4 DIA.	-61033		23	7705360 P2	465	7713488 P3	1		S4A, B, S5A, B, C
X	X		INSULATOR FOR S4A & S4B	SAME AS ITEM 39					466	7613489 P8			
4	4		BRUSH FOR S4A & S4B	NICKEL SILVER			1	7708696 P4	467	7713488 P5	1		S4A, S4B, S9
4	4		BRUSH FOR S4A & S4B	NICKEL SILVER			1	7708696 P5	468	7713488 P6	1		S4A, S4B, S9
4	4		BRUSH FOR S4A & S4B	NICKEL SILVER			1	7708696 P6	469	7713488 P7	1		S4A, S4B, S9
15	15		CONTACTS FOR S4A & S4B	BRASS 1/2 OF 7/16 HEX. #8-32 THREAD			1	7805141 P2	470	7613489 P11	4		S4A, B, S5A, B, C
1	1	S5A	SWITCH - ANTENNA TRANSFOER HIGH-LOW POWER	THREE POLE, D.T., ONE BREAK PER CIRCUIT, 10 AMPS., R.F. OR D.C. 3000 VOLTS, ROTARY TYPE.			1		471	7613331 G1	0		S5A, S5B, S5C

82-9

PARTS AND SPARE PARTS FOR TBK-20 RADIO TRANSMITTING EQUIPMENT										SPARE PARTS			
TOTAL USED PER EQUIP		SYMBOL DESIG.	FUNCTION	DESCRIPTION	NAVY TYPE NUMBER	NAVY SPEC. NUMBER	MFR.	MFR. DESIG.	CONTRACTOR'S ITEM NO.	CONTRACTOR'S DRAWING NUMBER	EQUIP.		ALL SYMBOL DESIGNATIONS INVOLVED
115 DC	230 DC										BOX NUMBER	QUANTITY	
X	X	S5B	SWITCH - P.A. SCREEN GRID, HIGH-LOW POWER	PART OF S5A					472	7607284 P313			
X	X	S5C	SWITCH - HIGH-LOW POWER P.A. PLATE SWITCH	PART OF S5A					473	7607284 P314			
1	1		PANEL FOR S5A,B,C	MICARTA 7 1/2 X 7 X 1/4 TK.				1	7415415 P1	474	7713515 P2	0	S5A,B,C
1	1		INSULATOR FOR S5A,B,C	ISOLANTITE 3 5/8 DIA. X 3/8 TK	-61219			23	7806456 P1	475	7713487 P4	1	S5A,B,C
X	X		INSULATOR FOR S5A,B,C	SAME AS ITEM 465	-61033					476	7713487 P5		
X	X		INSULATOR FOR S5A,B,C	SAME AS ITEM 54	-61084					477	7613331 P14		
3	3		BRUSH FOR S5A,B,C	NICKEL SILVER				1	7708696 P1	478	7713487 P5	1	S5A,B,C
3	3		BRUSH FOR S5A,B,C	NICKEL SILVER				1	7708696 P2	479	7713487 P6	1	S5A,B,C
3	3		BRUSH FOR S5A,B,C	NICKEL SILVER				1	7708696 P3	480	7713487 P7	1	S5A,B,C
X	X		CONTACT FOR S5A,B,C	SAME AS ITEM 470						481	7613331 P17		
1	1		SPRING FOR S5A,B,C	PHOS. BRONZE 3/8 DIA.				1	7809803 P1	482	7613331 P7	0	S5A,B,C
1	1	S6	SWITCH - ANTENNA CURRENT VOLTAGE FEED	D.P.D.T., ONE BREAK PER CIRCUIT, 20 AMPS. R.F., 3000 VOLTS, ROTARY TYPE				1		483	7613686 G1	0	S6
1	1		PANEL FOR S6	MICARTA 9 1/4 X 4 1/2 X 1/4 TK.				1	7415896 P1	484	7713515 G6	0	S6
X	X		INSULATOR FOR S6	SAME AS ITEM 94	-61029					485	7613686 P21		
4	4		INSULATOR FOR S6	ISOLANTITE	-61061			23	7602239 P4	486	7613686 P15	2	S6
2	2		BRUSH FOR S6	NICKEL SILVER				1	7602913 P2	487	7613686 P17	1	S6
2	2		BRUSH FOR S6	NICKEL SILVER				1	7602913 P3	488	7613686 P18	1	S6
2	2		BRUSH FOR S6	NICKEL SILVER				1	7602913 P4	489	7613686 P19	1	S6
6	6		CONTACT FOR S6	BRASS 11/16 X 7/8 HEX., #10-32 THREAD				1	7805141 P5	490	7613686 P24	2	S6

62-9

PARTS AND SPARE PARTS FOR TBK-20 RADIO TRANSMITTING EQUIPMENT

SPARE PARTS

TOTAL USED PER EQUIP	SYMBOL DESIG.	FUNCTION	DESCRIPTION	NAVY TYPE NUMBER	NAVY SPEC. NUMBER	MFR.	MFR. DESIG.	CONTRACTOR'S ITEM NO.	CONTRACTOR'S DRAWING NUMBER	EQUIP.		ALL SYMBOL DESIGNATIONS INVOLVED
										BOX NUMBER	QUANTITY	
115 DC												
230 DC												
1	1	SPRING FOR S6	PHOS. BRONZE 3/8 DIA.			19	7807511 P4	491	7613686 P9	0		S6
1	1	S7 SWITCH-REMOTE-LOCAL	FOUR POLE D.T., ONE BREAK PER CIRCUIT 2 AMPS., 220 VOLTS, TOGGLE TYPE	-24086		14,18		492	7707082 P2	1		S7
1	1	S8 SWITCH - 4 WIRE, START-STOP	D.P.S.T., 10 AMPS. AT 250 V.A.C. PUSH BUTTON TYPE			1		493	7707242 G4	0		S8
0	0	SWITCH - 4 WIRE, START-STOP	SPARE FOR S8					494	7707242 G10	1		S8
1	1	S9 SWITCH -ADJUST - TUNE OPERATE WITH INTERLOCK	D.P. TRIPLE THROW, ONE BREAK EACH IN TWO CIRCUITS, 3 AMPS., 3000 VOLTS D.C. ROTARY TYPE, INTERLOCK SAME AS S1C					495	7613707 G2	0		S9
1	1	PANEL FOR S9	MICARTA 8 X 5 1/4 X 1/4 TK.			1	7416043 P1	496	7713515 G9	0		S9
1	1	INSULATOR FOR S9	ISOLANTITE 1 1/8 X 1 3/4 DIA.			1	7705360 P25	497	7713488 P17	1		S9
1	1	ARM FOR S9	MICALEX 2 3/4 X 1 3/4 X 1/4 TK			1	7808468 P1	498	7713488 P4	0		S9
8	8	INSULATOR FOR S9	ISOLANTITE	-61028		1	7602239 P1	499	7613707 P24	4		S9
8	8	CONTACT FOR S9	BRASS 3/8 OF 7/16 HEX., #8-32 THREAD			1	7805141 P6	500	7613707 P28	2		S9
X	X	CONTACT FOR S9	SAME AS ITEM 467					501	7713488 P5			
X	X	CONTACT FOR S9	SAME AS ITEM 468					502	7713488 P6			
X	X	CONTACT FOR S9	SAME AS ITEM 469					503	7713488 P7			
1	1	S9A INTERLOCK FOR S9	S.P.S.T. NORMALLY CLOSED PART OF S9			1	7412580 G1	504	7613707 P31	1		S9A
1	1	SPRING FOR S9	PHOS. BRONZE 3/8 DIA.			19	7807511 P8	505	7613707 P35	0		S9
1	1	S10 SWITCH - TEST KEY	D.P.D.T., OPEN NEUTRAL AND NON-LOCK 10 AMPS. A.C., 2 AMPS. D.C. AT 110 VOLTS TOGGLE TYPE	-24069A		14,18		506	7707082 P1	1		S10
1	1	S11 SWITCH - TEMPERATURE PROTECTION	S.P.S.T., TWO BREAKS PER CIRCUIT SPENCER DISC, OPEN 89°C TO 70°C CLOSE AT 55°C TO 60°C, 3.0 AMPS. AT 330 VOLTS D.C. OR 2.5 AMPS. AT 220 VOLTS, 60 CYCLE	-40034		1	S#1022783	507	7406282 P1	1		S11

06-9

PARTS AND SPARE PARTS FOR TBK-20 RADIO TRANSMITTING EQUIPMENT										SPARE PARTS			
TOTAL USED PER EQUIP	SYMBOL DESIG.	FUNCTION	DESCRIPTION	NAVY TYPE NUMBER	NAVY SPEC. NUMBER	MFR.	MFR. DESIG.	CONTRACTOR'S ITEM NO.	CONTRACTOR'S DRAWING NUMBER	EQUIP		ALL SYMBOL DESIGNATIONS INVOLVED	
										BOX NUMBER	QUANTITY		
116 DC	230 DC												
1	1	S12	SWITCH-EMERGENCY STOP	D.P.D.T., TWO BREAKS PER CIRCUIT 30 AMPS., 250 VOLTS, THUMBLER TYPE	-24072			13	508	7706780 P2	1	S12	
1	1	S13	SWITCH - THERMOSTAT	60°C., PLATINUM CONTACTS SET WITHIN 0.05°C., SINGLE CIRCUIT, DOUBLE BREAK, ANGLE TYPE.	-40010	RE13A486C		15	509	7603330 P32	1	S12	
3	3	S14	SWITCH - DOOR INTERLOCK	SINGLE CIRCUIT, DOUBLE BREAK, 1 AMP 500 V., INTERLOCK TYPE	-24067		867378	1	510	7607284 P324	1	S14, S15, S16	
X	X	S15	SWITCH - DOOR INTERLOCK	SAME AS S14	-24067				511	7607284 P325			
X	X	S16	SWITCH - DOOR INTERLOCK	SAME AS S14	-24067				512	7607284 P326			
1	1	S17	SWITCH - 6 WIRE, START-STOP	TWO BUTTON, MOMENTARY, 10 AMPS., 250 V.A.C., PUSH BUTTON TYPE				1	0908	513	7707242 G3	0	S17
0	0		SWITCH - 6 WIRE, START-STOP	SPARE FOR S17					514	7707242 G9	1		
1	1	T1	TRANSFORMER - FILAMENT	0.211 KVA., 60 CYCLE WDG. TAPS VOLTS AMPS TURNS OHMS P1 4 TO 6 100 1.18 113 1.2 P1 5 TO 6 70 1.70 79 1.0 P2 1 TO 3 100 1.18 113 1.2 P2 1 TO 2 70 1.70 79 1.0 S1 7 TO 8 6.7 10 7 .018 S1 7 TO 9 11.4 10 13.5 .032 S2 13 TO 14 5 6.5 6 .025 S2 13 TO 15 10 6.5 12 .05 S3 10 TO 11 5.5 3.25 6.5 .04 S3 10 TO 12 11 5.25 13. .08 TEST 2500 VOLTS	-30302			1	515	L317196	1	T1	
		T2	NOT USED										
1	1	T3	TRANSFORMER-COMPENSATOR	1.2 WATTS, 60 CYCLE PRIMARY 100 V., .012 AMP., 4180 TURNS, 675 OHMS, SECONDARY 0.125V., 10 AMPS., 10 TURNS, .009 OHM TEST 1500 VOLTS				1	516	L332701	1	T3, C62	
1	1	TH1	THERMOMETER - M.O. TEMP.	CALIBRATED 30°C TO 70°C, STEM 7" X 1/4", ANGLE TYPE	-40025			15	517	7603258 P28	1	TH1	

PARTS AND SPARE PARTS FOR TBK-20 RADIO TRANSMITTING EQUIPMENT											SPARE PARTS	
TOTAL USED PER EQUIP	SYMBOL DESIG.	FUNCTION	DESCRIPTION	NAVY TYPE NUMBER	NAVY SPEC. NUMBER	MFR.	MFR. DESIG.	CONTRACTOR'S ITEM NO.	CONTRACTOR'S DRAWING NUMBER	EQUIP.		ALL SYMBOL DESIGNATIONS INVOLVED
										BOX NUMBER	QUANTITY	
118 DC												
230 DC												
3	3	VT-1	TUBE - R.F. OSCILLATOR	(TRANSMITTING TETRODE) R.F. SCREEN GRID OSCILLATOR OR POWER AMPLIFIER GLASS BASE, MEDIUM 4 PIN BAYONET, CERAMIC GRID & PLATE LEADS ARE SEPARATE LEADS THRU GLASS BULB HEATER CURRENT 3.25 AMPS. AT 10 VOLTS A.C. OR D.C. PLATE DISSIPATION 100 WATTS	-860	RE-13A-600A	1	WL-860	518	7502199 P7	6	VT1,VT2,VT3
X	X	VT2	TUBE - R.F. 1ST INT. POWER AMP.	SAME AS VT1	-860				519	7607284 P355		
X	X	VT3	TUBE - R.F. 2ND INT. POWER AMP.	SAME AS VT1	-860				520	7607284 P356		
1	1	VT4	TUBE - R.F. POWER AMP.	R.F. SCREEN GRID POWER AMP. GLASS BASE, SPECIAL 2 PIN BAYONET AND ONE BAR CONTACT CERAMIC SCREEN GRID & PLATE. SPECIAL CAPS, CURRENT LEAD THRU SIDE OF GLASS BULB. HEATER CURRENT 10 AMPS. AT 11 VOLTS A.C. OR D.C. PLATE DISSIPATION 400 WATTS	-861	RE-13A-600A	1		521	7502199 P6	2	VT4
3	3	X1	SOCKET - M.O. TUBE	7 1/2 WATT, 4 CONTACTS, BAYONET TYPE	-49309		1		522	7608251 P16	2	X1,X2,X3
X	X		BINDING POST FOR X-1	SAME AS ITEM 40					523			
X	X	X-2	SOCKET - 1ST INT. AMP. TUBE	SAME AS X-1	-49309				524	7607285 P362		
X	X		BINDING POST FOR X-2	SAME AS ITEM 40					525			
X	X	X-3	SOCKET 2ND INT. AMP. TUBE	SAME AS X-1	-49309				526	7607285 P363		
X	X		BINDING POST FOR X-3	SAME AS ITEM 40					527			
1	1	X-4	SOCKET - P.A. TUBE	FILAMENT FOR TUBE TYPE-861	-49316A		1		528	7705850 G2	1	X-4
1	1	X-5	SOCKET - P.A. TUBE	GRID FOR TUBE TYPE-861	-49315A		1		529	7705850 G1	1	X-5
X	X		BINDING POST FOR X-5	SAME AS ITEM 40					530			
4	4		SHOCK-MOUNTS FOR X-4 & X-5				26	CAT. #100 P4	531	7810310 P33	0	
1	1		PLATE FOR X-4	MICARTA 7 x 2 x 3/16 TK.			1	7806322 P3	532	7708995 P4	0	X4
1	1		SUPPORT FOR R8,R10,R12,R23,R24,R25	MICARTA 14 1/2 x 1 1/2 x 1/2 TK			1	7405501 P3	533	7406205 P4	0	R8,R10,R12,R23,R24,R25
1	1		SUPPORT FOR R8,R10,R12,R23,R24,R25	MICARTA 14 1/2 x 1 1/2 x 1/2 TK			1	7405501 P4	534	7406205 P3	0	R8,R10,R12,R23,R24,R25

PARTS AND SPARE PARTS FOR TBK-20 RADIO TRANSMITTING EQUIPMENT

SPARE PARTS

TOTAL USED PER EQUIP.	SYMBOL DESIG.	FUNCTION	DESCRIPTION	NAVY TYPE NUMBER	NAVY SPEC. NUMBER	MFR.	MFR. DESIG.	CONTRACTOR'S ITEM NO.	CONTRACTOR'S DRAWING NUMBER	EQUIP.		ALL SYMBOL DESIGNATIONS INVOLVED
										BOX NUMBER	QUANTITY	
115 DC	230 DC											
2	2	SUPPORT FOR R4,R7,R17,R29,R32 R34,R35	MICARTA 6 1/2 X 1 X 1/2 TK.			1	7705854 P3	535	7606329 P38	0		R4, R7, R17, R29, R32, R34, R35
1	1	SUPPORT FOR R4,R7,R17,R29,R32 R34,R35	MICARTA 6 1/2 X 3 3/4 X 1/2 TK.			1	7705854 P7	536	7606329 P34	0		R4, R7, R17, R29, R32, R34, R35
1	1	SUPPORT FOR R1,R2,R3,R15,R16, R19,R21,R28,R45,R46,R47,R48	MICARTA 23 X 2 1/2 X 1/2 TK.			1	7707030 P2	537	7606329 P4	0		R1,R2,R3,R15,R16,R19,R21,R28, R45,R46,R47,R48
1	1	SUPPORT FOR R1,R2,R3,R15,R16, R19,R21,R28,R45,R46,R47,R48	MICARTA 23 X 2 1/2 X 1/2 TK.			1	7707030 P4	538	7606329 P65	0		R1,R2,R3,R15,R16,R19,R21,R28, R45,R46,R47,R48
1	-	PANEL FOR MAG. CON.	MICARTA 16 3/4 X 12 X 3/4 TK.					539	45-J-406 P19	0		
-	1	PANEL FOR MAG. CON.	SAME AS ITEM 539					540		0		
1	1	FUSE PANEL FOR G221	MICARTA			1	74-C-392	541	33-J-174 P64	0		
8	8	FUSE INSULATOR FOR G221	CERAMIC					542	33-J-174 P113	4		
1	1	FUSE PANEL FOR G-211	MICARTA			1	74-C-546	543	33-J-176 P63	0		
X	X	FUSE INSULATORS FOR G-211	SAME AS ITEM 542			1		544	33-J-176 P67	0		
1	1	SUPPORT FOR ITEMS 399 400, 401, 402,	MICARTA 15 3/8 X 1 X 1 TK.			1	7407731 P1	545	7710310 P79	0		
1	1	CONTACTOR PANEL	MICARTA 30 1/4 X 11 7/8 X 1/2 TK.			1	7606132 P3	546	7607287 P3	0		C67,F1,F2 K2,K5,K7,K14,K19, M9R
1	1	SHAFT EXTENSION FROM S6 TO CONTROL "G"	MICARTA 14 3/4 OF 3/4 DIA.			1	7604199 P2	547	7604199 P2	0		S6, CONTROL "G"
2	2	SUPPORT FOR R11,R13,R18	MICARTA 7 1/4 X 1 X 1/2 TK.			1	7707030 P3	548	7606329 P27	0		R11,R13,R18
1	1	INSULATING SPACER FOR M.O. DIAL				1	7406751 P1	549	7810261 P25	0		M.O. DIAL
1	1	EXTENSION FROM S1A & B TO CONTROL "A"	MICARTA TUBE 5 25/32 OF 3/4 O.D. X 5/16 I.D.			1	7810368 P1	550	7405714 P6	0		S1A,B,CONTROL "A"
1	1	INSULATOR FOR S13	MICARTA 3 3/4 X 27/32 X 1/16 TK.			1	7405465 P3	551	7810261 P31	0		S13
1	1	TERM. BD. FOR M.O. UNIT	MICALEX 5 1/2 X 1 3/4 X 3/16 TK.			1	780885 P1	552	7705829 P7	0		M.O. UNIT
1	1	SUPPORT FOR X1	MICALEX 3 X 3 X 1/8 TK.			1	7808541 P1	553	7705829 P10	0		X1
2	2	SUPPORT FOR X1	MICALEX 3 X 1/2 X 3/8 TK.			1	7808541 P2	554	7705829 P11	0		X1
6	6	SPACER-FEED THRU - TOP FLOOR P.A. FLOOR & M.O. UNIT	ISOLANTITE 17/32 OF 3/4 O.D. X 17/32 I.D.	-61123		23	7602239 P26	555	7702097 P2	3		

65-6

PARTS AND SPARE PARTS FOR TBK-20 RADIO TRANSMITTING EQUIPMENT											SPARE PARTS	
TOTAL USED PER EQUIP	SYMBOL DESIG.	FUNCTION	DESCRIPTION	NAVY TYPE NUMBER	NAVY SPEC. NUMBER	MFR.	MFR. DESIG.	CONTRACTOR'S ITEM NO.	CONTRACTOR'S DRAWING NUMBER	EQUIP		ALL SYMBOL DESIGNATIONS INVOLVED
										BOX NUMBER	QUANTITY	
115 DC												
230 DC												
3	3	INSULATOR - FEED THRU-TOP FLOOR, P A. FLOOR & M.O. UNIT	ISOLANTITE 1 1/8 OF 1/2 O.D. X .206 I.D.	-61126		23	7405822 P2	556	7702097 P8		2	
2	2	INSULATOR FOR M9R	ISOLANTITE 2 X 23/32 SQ.	-61106		23	7705360 P13	557	7607287 P21		1	M9R
1	1	INSULATOR FOR VT1 CONN.	ISOLANTITE 3 X 3/4 DIA.	-61064		23	7602239 P6	558	7705829 P16		1	VT1 CONN.
2	2	INSULATOR-FEED THRU FOR M.O. UNIT	ISOLANTITE	-61116		23	7810261 P18	559	7810261 P18		1	L1
4	4	INSULATOR - FEED THRU FOR M.O. UNIT	ISOLANTITE	-61045		23	7810261 P19	560	7810261 P19		2	L2, VT1
12	12	BUSHING FOR FEED THRU INSULAT OR CONTACTOR PANEL	ISOLANTITE	-61128		23	7405822 P8	561	7702097 P20		3	CONTACTOR PANEL
4	4	INSULATOR FOR LARGE COUP.	ISOLANTITE - SPECIAL	-61132		23	7402096 P1	562	7607465 P4		2	
2	2	INSULATOR FOR SMALL COUP.	ISOLANTITE - SPECIAL	-61133		23	7402096 P2	563	7607465 P15		1	
24	24	INSULATOR - FEED THRU CONTACTOR PANEL	PRESTITE	-61123S		1	50-C-695 P1	564	7702097 P43		6	CONTACTOR PANEL
66	66	INSULATOR FOR RESISTOR MOUNT- ING	PRESTITE			1	50-C-682 P3	565	7406205 P16		10	R2, R3, R8, R10, R12, R15, R16, R18, R23, R24, R45, R46, R47, R48
1	1	COUPLING - LARGE C42				1	7607465 G16	566	7810310 P321		0	C42, CONTROL "J"
1	1	COUPLING - LARGE C41				1	7607465 G12	567	7604452 P22		0	C41, CONTROL "H"
1	1	COUPLING - LARGE C21				1	7607465 G22	568	7810310 P30		0	C21, CONTROL "D"
3	3	COUPLING - LARGE L9, L13, L14				1	7607465 G10	569	7409127 P42		0	L9, CONTROL "E" L13, CONTROL "K" L14, CONTROL "F"
1	1	COUPLING - SMALL L9, C29				1	7607465 G13	570	7810310 P281		0	L9, C29
1	1	COUPLING - SMALL L14, C39				1	7607465 G14	571	7810310 P322		0	L14, C39
1	1	COUPLING - L1, CONTROL "C"				1	7710266 G2	572	7810261 P89		0	L1, CONTROL "C"
4	4	SPRING FOR M.O. UNIT - TOP	STEEL - 1/2 I.D., .125 DIA. WIRE			19	7807085 P15	573	7810310 P101		0	M.O. SUPPORT
4	4	SPRING FOR M.O. UNIT-BOTTOM	STEEL 1/2 I.D., .095 DIA. WIRE			19	7817085 P25	574	7810310 P102		0	M.O. SUPPORT
4	4	SPRING FOR P.A. TUBE DOOR & BOTTOM DOOR	PHOS. BRONZE 3/8 LG. X 7/16 I.D.			19	7805297 P3	575	7706392 P5		0	DOOR CATCHES
2	2	SPRING FOR DOOR STAY	NICKEL SILVER - SPECIAL			1	7705787 P7	576	7705787 P7		0	
1	1	CONTROL "B" SPARE	M.O. DIAL LESS DENTENT MECHANISM FOR SIC			1	7604980 G7	577			0	
1	1	CONTROL "D"	1ST I.A. TUNING DIAL WITH NP-19388 "D" ATTACHED			1	7609308 G8	578	7810310 P8		0	CONTROL "D"

PARTS AND SPARE PARTS FOR TBK-20 RADIO TRANSMITTING EQUIPMENT

SPARE PARTS

TOTAL USED PER EQUIP		SYMBOL DESIG.	FUNCTION	DESCRIPTION	NAVY TYPE NUMBER	NAVY SPEC. NUMBER	MFR.	MFR. DESIG.	CONTRACTOR'S ITEM NO.	CONTRACTOR'S DRAWING NUMBER	EQUIP		ALL SYMBOL DESIGNATIONS INVOLVED
115 DC	230 DC										BOX NUMBER	QUANTITY	
1	1		CONTROL "J"	ANT. TUNING CAPACITOR DIAL WITH NP-19388 "J" ATTACHED			1	7609308 G1	579	7810310 P9		0	CONTROL "J"
1	1		CONTROL "K"	ANTENNA TUNING COIL DIAL WITH NP-19388 "K" ATTACHED			1	7609317 G3	580	7810310 P10		0	CONTROL "K"
1	1		CONTROL "H"	ANT. COUPLING CAPACITOR DIAL WITH NP-19388 "H" ATTACHED			1	7609317 G1	581	7810310 P11		0	CONTROL "H"
1	1		CONTROL "F"	P.A. TUNING COIL DIAL WITH NP-19388 "F" ATTACHED			1	7609317 G2	582	7810310 P12		0	CONTROL "F"
1	1		CONTROL "E"	2ND I.A. DIAL WITH NP-19388 "E" ATTACHED			1	7609317 G2	583	7810310 P13		0	CONTROL "E"
1	1		CONTROL "C"	M.O. TANK COIL DIAL WITH NP-19388 "C" ATTACHED			1	7609308 G2	584	7705824 P29		0	CONTROL "C"
6	6		FUSE CLIPS FOR G-211				1	S#585296	585	33-J-176 P68		1	
4	4		FUSE CLIPS FOR G-211				1	S#585295	586	33-J-176 P85		2	
X	X		FUSE CLIPS FOR G-221	SAME AS ITEM 585					587	33-J-174 P94			
X	-		FUSE CLIPS FOR MAG. CON.	SAME AS ITEM 586					588	45-J-408 P14			
-	X		FUSE CLIPS FOR MAG. CON.	SAME AS ITEM 586					589				
2	2		GREASE CUP FOR G-211				1	S#1295095	590	33-J-176 P109		0	
4	4		GREASE CUP FOR G-221				1	S#1266326	591	33-J-174 P81		0	
-	X		GREASE CUP FOR B-241	SAME AS ITEM 591					592				
X	-		GREASE CUP FOR B-271	SAME AS ITEM 591					593				
-	5		GASKET FOR B-241				1	33-R-4	594	5-D-7928		5	
5	-		GASKET FOR B-271	SAME AS ITEM 594					595			5	
14	14		GASKET FOR G-211				1	5-D-7928	596	33-J-176 P59		14	
X	X		GASKET FOR G-221	SAME AS ITEM 596					597	33-J-174 P121			
52	52		CLIP	FOR MOUNTING RESISTORS			1	7610465 P3	598	7606329 P6, P66		5	
10	10		CLIP	FOR MOUNTING RESISTORS			1	7403619 P1	599	7606329 P35		1	
2	2		CLIP	FOR DOOR STAY			1	106870 P1	600	7705787 P6		0	
29	29		THUMB-SCREW	SLOTTED FOR SHIELDS - 1 1/8 LG.			1	7406179 P6	601	7607286 P29		0	
19	19		THUMB SCREW	SLOTTED FOR SHIELD - 1 3/8 LG.			1	7406179 P7	602	7607286 P30		0	

54-9

PARTS AND SPARE PARTS FOR TBK-20 RADIO TRANSMITTING EQUIPMENT										SPARE PARTS		
TOTAL USED PER EQUIP	SYMBOL DESIG.	FUNCTION	DESCRIPTION	NAVY TYPE NUMBER	NAVY SPEC. NUMBER	MFR.	MFR. DESIG.	CONTRACTOR'S ITEM NO.	CONTRACTOR'S DRAWING NUMBER	EQUIP		ALL SYMBOL DESIGNATIONS INVOLVED
										BOX NUMBER	QUANTITY	
115 DC	230 DC											
10	10	THUMB SCREW	PLAIN FOR SHIELD - 1 LG.			1	7406179 P14	603	7605482 P4		0	
8	8	FULCRUM SCREW FOR S5	FOR DETENT ARMS			1	7816704 P2	604	7603470 P52		0	S2,S5,S6,S9
2	2	SHOULDER SCREW	FOR DOOR STAYS			1	7705787 P9	605	7705787 P9		0	
2	-	THUMB SCREW FOR MAG.CON.DOOR				1	S#1289362	606			0	
-	2	THUMB SCREW FOR MAG.CON.DOOR	SAME AS ITEM 606					607			0	
3	3	TERMINAL BLOCK	MICARTA - 12 SECTIONS			1	S#1225376	608	7707047 P4		0	
2	2	TERMINAL BLOCK	MICARTA - 5 SECTIONS			1	S#1225374	609	7810310 P297		0	
4	4	TERMINAL BLOCK	MICARTA - 10 SECTIONS			1	S#1225376	610	7810310 PTS.409 410,411,412		0	
4	4	SHOCK-MOUNTS FOR B-1				26	S#100-PH-4	611	7706786 P8		2	
		TERMINAL	FOR #6 SCREW			1	S#552413	612			12	
		TERMINAL	FOR #8 SCREW			1	S#867558	613			12	
		TERMINAL	FOR #10 SCREW			1	S#867556	614			12	
		TERMINAL	FOR 1/4 SCREW			1	S#867563	615			12	
		WIRE	300 V. HOOK-UP WIRE #16 BLACK					616			3FT.	
		WIRE	LENZ "AEROGLAS" 65 OF .010 WHITE			16	5 MV	617			20FT	

95-9

TABLE III

PARTS LIST BY NAVY TYPE NUMBERS FOR MODEL TBK-20 RADIO TRANSMITTING EQUIPMENT

115 D C	230 D C	NAVY TYPE NUMBER	ALL SYMBOL DESIGNATIONS INVOLVED	115 D C	230 D C	NAVY TYPE NUMBER	ALL SYMBOL DESIGNATIONS INVOLVED	115 D C	230 D C	NAVY TYPE NUMBER	ALL SYMBOL DESIGNATIONS INVOLVED
MISCELLANEOUS CLASS 10				MISCELLANEOUS (CONTINUED) CLASS 10				MOTORS AND GENERATORS CLASS 21			
2	2		E-211, E-221	0	1		E-247A	1	1	-21131B	B-1
1	1		E-212	2	2		E-248, E-278	1	0	-21678	B-271
1	1		E-213	X	X		E-248 E-278	0	1	-21681	B-241
2	2		E-214, E-224	2	2		E-249, E-279	1	1		B-1A
2	2		E-214A, E-224A	X	X		E-249 E-279	1	1		B-1B
2	2		E-215A, E-225A	0	1		E-250	ELECTRICAL INDICATING INSTRUMENTS CLASS 22			
2	2		E-215B, E-225B	1	0		E-271				
1	1		E-217	1	0		E-277A	1	1	-22035	M-1
1	1		E-222	1	0		E-281	1	1	-22056	M-8
1	1		E-223	1	0		E-282	3	3	-22059	M-3, M-5, M-7
1	1		E-228	1	0		E-284	2	2	-22065	M-4, M-6
0	1		E-241	2	2		I-2C, I-3C, I-6C	1	1	-22067	M-2
2	2		E-242, E-272	X	X		I-2C, I-3C I-3C, I-6C	1	1	-22080	M-11
X	X		E-242 E-272	1	1		I-4C	1	1	-22199C	M-10
0	1		E-243	1	1		I-5C	1	1	-22225	M-12
0	1		E-244	0	1		I-6A	1	1	-22311	M-9
2	2		E-245, E-283	1	1		O-213	M-9R (SEE CLASS 63)			
X	X		E-245 E-283	3	3		O-214, O-224, O-242, O-274				
2	2		E-245A, E-275A	X	X		O-214, O-224, O-274	SWITCHES CLASS 24			
X	X		E-245A E-275A	2	2		O-214, O-224, O-242				
2	2		E-246, E-276	X	X		O-223, O-241, O-273	3	3	-24067	S-14, S-15, S-16
X	X		E-246 E-276				O-223, O-273	1	1	-24069A	S-10
2	2		E-247, E-277				O-223, O-241	1	1	-24072	S-12
X	X		E-247 E-277					1	1	-24086	S-7
								3	3	-24095A	S-3A, S-3B, S-3C

TABLE III

PARTS LIST BY NAVY TYPE NUMBERS FOR MODEL TBK-20 RADIO TRANSMITTING EQUIPMENT

115 D C	230 D C	NAVY TYPE NUMBER	ALL SYMBOL DESIGNATIONS INVOLVED	115 D C	230 D C	NAVY TYPE NUMBER	ALL SYMBOL DESIGNATIONS INVOLVED	115 D C	230 D C	NAVY TYPE NUMBER	ALL SYMBOL DESIGNATIONS INVOLVED
SWITCHES (CONTINUED) CLASS 24				FUSES (CONTINUED) CLASS 28				VACUUM TUBES CLASS 38			
1	1		S-1A (PART OF L-1)	1	1		F-841, F-851	3	3	-860	VT-1, VT-2, VT-3
1	1		S-1B (PART OF L-1)	X	X		F-841 F-851	1	1	-861	VT-4
1	1		S-1C	RELAYS CLASS 29				THERMOMETERS AND THERMOSTATS CLASS 40			
1	1		S-2A								
1	1		S-2B (MOUNTED ON L-14)	1	1	-29058	K-2	1	1	-40010	S-13
1	1		S-2C	1	1	-29062	K-9	1	1	-40025	TH-1
1	1		S-2D (MOUNTED ON L-9)	1	1	-29064	K-4	1	1	-40034	S-11
1	1		S-2E	1	1	-29169	K-1	INDUCTORS AND CHOKES CLASS 47			
1	1		S-4A, S-4B	1	1	-29195	K-5				
1	1		S-5A, S-5B, S-5C	1	1	-29196	K-7	1	1		L-1
1	1		S-6	1	1		K-20	1	1		L-2
1	1		S-8	1	1		K-841, K-851	1	1		L-3
1	1		S-9, S-9A	X	X		K-841 K-851	1	1		L-4
1	1		S-11 (SEE CLASS 40)	2	2		K-842, K-843, K-852, K-853	3	3		L-5, L-17, L-18
1	1		S-13 (SEE CLASS 40)	X	X		K-842, K-843 K-852, K-853	2	2		L-6, L-8
1	1		S-17	1	0		K-844	1	1		L-7
FUSES CLASS 28				0	1		K-854	1	1		L-9
F-1, F-2				REACTORS AND TRANSFORMERS CLASS 30				2	2		L-10, L-15
2	2		F-211	1	1	-30185	L-16	1	1		L-11
1	1		F-212	1	1	-30302	T-1	1	1		L-12
1	1		F-221	1	1		T-3	1	1		L-13
1	1		F-222					1	1		L-14
											L-19

85-9

TABLE III

PARTS LIST BY NAVY TYPE NUMBERS FOR MODEL TBK-20 RADIO TRANSMITTING EQUIPMENT

115 D C	230 D C	NAVY TYPE NUMBER	ALL SYMBOL DESIGNATIONS INVOLVED	115 D C	230 D C	NAVY TYPE NUMBER	ALL SYMBOL DESIGNATIONS INVOLVED	115 D C	230 D C	NAVY TYPE NUMBER	ALL SYMBOL DESIGNATIONS INVOLVED
CAPACITORS CLASS 48				CAPACITORS (CONTINUED) CLASS 48				INSULATORS (CONTINUED) CLASS 61			
1	1	-48001-10	C-67	1	1	-481214-5	C-66	8	8	-61030	
10	10	-48027-10	C-4, C-5, C-8, C-9, C-17, C-18, C-26, C-27, C-35, C-36	1	1	-481215-5	C-40	2	2	-61032	
2	2	-48035-10	C-19, C-28	1	1	-481216-5	C-49	2	2	-61033	
6	6	-48057-10	C-12, C-16, C-25, C-33, C-34, C-37	1	1		C-13	4	4	-61045	
1	1	-48039-10	C-15	1	1		C-14	5	5	-61061	
1	1	-48024-D2	C-7	1	1		C-21	1	1	-61064	
1	1	-48205-A10	C-60	1	1		C-29	1	1	-61068	
1	1	-48218-5	C-44	1	1		C-39	15	15	-61084	
1	1	-48330-10	C-22	1	1		C-41	2	2	-61106	
1	1	-48365-D2	C-2	1	1		C-42	3	3	-61107	
2	2	-48382-10	C-20, C-30	1	1		C-55	2	2	-61116	
11	11	-48410-10	C-10, C-11, C-23, C-24, C-31, C-32, C-43, C-46, C-50, C-51, C-52	1	1		C-61	6	6	-61118	
1	1	-48423-5	C-57	1	1		C-62	6	6	-61123	
2	2	-48477-D2	C-1, C-3	1	1		C-68	24	24	-61123S	
1	1	-48478-B5	C-6	JACKS AND VACUUM TUBE SOCKETS CLASS 49				3	3	-61126	
1	1	-48481-D2	C-56	1	1	-49110	J-1	12	12	-61128	
1	1	-48534-5	C-54	3	3	-49309	X-1, X-2, X-3	6	6	-61130	
1	1	-48535-5	C-53	1	1	-49315A	X-5	4	4	-61132	
1	1	-48683-10	C-47	1	1	-49316A	X-4	2	2	-61133	
1	1	-48684-10	C-48	INSULATORS CLASS 61				1	1	-61219	
2	2	-48685-10	C-58, C-65	13	13	-61028		2	2	-61232	
3	3	-48686-10	C-45, C-63, C-64	8	8	-61029		5	5	-61422S	
								5	5	-61423S	
								18	18	-61462	

TABLE III

PARTS LIST BY NAVY TYPE NUMBERS FOR MODEL TBK-20 RADIO TRANSMITTING EQUIPMENT

115 D C	230 D C	NAVY TYPE NUMBER	ALL SYMBOL DESIGNATIONS INVOLVED	115 D C	230 D C	NAVY TYPE NUMBER	ALL SYMBOL DESIGNATIONS INVOLVED	115 D C	230 D C	NAVY TYPE NUMBER	ALL SYMBOL DESIGNATIONS INVOLVED
RESISTORS, RHEOSTATS AND POTENTIOMETERS CLASS 63				RESISTORS, RHEOSTATS AND POTENTIOMETERS (CONTINUED) CLASS 63							
1	1	-63067E	R-30	0	1	-63733E	R-34				
0	1	-63069E	R-7	1	1	-63775	M-9R				
0	2	-63071E	R-29, R-32	1	1		R-6				
0	1	-63077E	R-36	1	1		R-26				
2	2	-63085E	R-4, R-17	1	1		R-33				
1	1	-63097E	R-22	1	0		R-58				
1	1	-63141E	R-12	1	0		R-841				
5	5	-63149E	R-8, R-10, R-18, R-23, R-25	1	1		R-843, R-853				
1	1	-63159E	R-24	X	X		R-843				
4	4	-63204E	R-45, R-46, R-47, R-48	0	1		R-853				
1	1	-63212E	R-3				R-851				
1	1	-63224E	R-11								
5	5	-63227E	R-19, R-21, R-28								
1	1	-63233E	R-16								
1	1	-63236E	R-15								
1	1	-63257E	R-13								
1	1	-63288	R-50								
0	1	-63289	R-49								
1	1	-63361	R-2								
2	2	-63426	R-14, R-20								
1	1	-63484E	R-1								
0	1	-63506E	R-57								
1	0	-63553E	R-56								
1	0	-63732E	R-35								

of 9

TABLE IV
 APPLICABLE COLOR CODES AND MISCELLANEOUS DATA
 FOR MODEL TBK-20 RADIO TRANSMITTING EQUIPMENT

COLOR CODE IN MMFD. FOR CAPACITORS

COLOR	1ST DIGIT A	2ND DIGIT B	CIPHERS C
BLACK	-	0	.0
BROWN	1	1	0
RED	2	2	00
ORANGE	3	3	000
YELLOW	4	4	0000
GREEN	5	5	00000
BLUE	6	6	000000
PURPLE	7	7	0000000
GRAY	8	8	00000000
WHITE	9	9	--

RCA COLOR CODED CAPACITORS CAPACITY IN MMFD.

VALUES DESIGNATE TOLERANCE BY COLOR

YELLOW ±20% BLUE ±10% BLACK ±5%

RMA COLOR CODE FOR RESISTORS

COLOR	1ST DIGIT A	2ND DIGIT B	CIPHERS C
BLACK	-	0	.0
BROWN	1	1	0
RED	2	2	00
ORANGE	3	3	000
YELLOW	4	4	0000
GREEN	5	5	00000
BLUE	6	6	000000
PURPLE	7	7	0000000
GRAY	8	8	00000000
WHITE	9	9	--

D- TOLERANCE CODE:

GOLD = 5% SILVER = 10% OMIT = 20%

ORIGINAL COLOR ARRANGEMENT FOR AXIAL LEADS

NEW COLOR ARRANGEMENT FOR AXIAL LEADS

STANDARD COLOR ARRANGEMENT FOR RADIAL LEADS

TABLE V
PARTS AND SPARE PARTS FOR TBK-20 RADIO TRANSMITTING EQUIPMENT

MANUFACTURERS

CODE NUMBER	MFG. PREFIX	NAME	ADDRESS
1	CAY	WESTINGHOUSE ELECTRIC & MFG. CO.	2519 WILKENS AVE., BALTO., MD.
2	CD	CORNELL DUBILIER	SO. PLAINFIELD, N.J.
3	CHC	HAMMARLUND MFG. CO.	424 WEST 33RD. ST., N.Y., N.Y.
4	CBK	ALLEN D. CARDWELL	81 PROSPECT ST., BROOKLYN, N.Y.
5	CLF	LITTLEFUSE, INC.,	4757 RAVENSWOOD AVE., CHICAGO, ILL.
6		BRYANT ELECTRIC CO.	BRIDGEPORT, CONN.
7	CSD	STRUTHERS DUNN, INC.	139 N. JUNIPER ST., PHILA., PA.
8	CN	NATIONAL ELEC. MACH. CO.	2014 5TH ST., N.E. WASH., D.C.
9	CNA	NATIONAL CO., INC.	61 SHERMAN ST., MALDEN, MASS.
10	CAO	WARD LEONARD ELECTRIC CO.,	MOUNT VERNON, N.Y.
11	CSA	STACKPOLE CARBON CO.	ST. MARY'S, PENNSYLVANIA
12	CCC	CONTINENTAL CARBON CO.	13900 LORAIN AVE., CLEVELAND, OHIO
13	CHH	ARROW HART & HEGEMAN,	HARTFORD, CONN.
14	CGC	GENERAL CONTROL CO.	CAMBRIDGE, MASS.
15	CPT	PRECISION INST. & THER. CO.	1434 BRANDYWINE ST., PHILA., PA.
16	CLE	LENZ ELECTRIC MFG. CO.,	1751 N. WESTERN AVE., CHICAGO, ILL.
17	CAW	AEROVOX CORP.	NEW BEDFORD, MASS.
18	CDM	D.P. MOSSMAN INC.	CHICAGO, ILL.
19		WALLACE BARNES CO.	BRISTOL, CONN.
	CMR	MICAMOLD RADIO CORP.	1087 FLUSHING AVE., BROOKLYN, N.Y.
	CSF	SPRAGUE SPECIALTIES CO.	NORTH ADAMS, MASS.
20	CAN	SANGAMO ELEC. CO.	SPRINGFIELD, N.J.
	CD	CORNELL DUBILIER	SO. PLAINFIELD, N.J.
	CSL	SOLAR MFG. CO.	BAYONNE, N.J.
	CAW	AEROVOX CORP.	NEW BEDFORD, MASS.
21	CSL	SOLAR MFG. CO.	BAYONNE, N.J.
22	CFA	BUSSMAN MFG. CO.	ST. LOUIS, MO.
23	CBU	ISOLANTITE INC.	343 COURTLAND ST., BELLEVILLE, N.J.
24	CEB	HUGH H. EBY	4700 STANTON AVE., PHILADELPHIA, PA.
25	CCB	CHARLES BOND	617-23 ARCH ST., PHILADELPHIA, PA.
26		LORD MFG. CO.	1635 W. 12 TH ST. ERIE, PA.
27		THE RAJAH CO.	LOCUST AVE., BLOOMFIELD, N.J.
28	CAO	WARD LEONARD ELECTRIC CO.	MT. VERNON, N. Y.
	CHD	HARDWICK-HINDLE, INC.	NEWARK, N. J.
	CSF	SPRAGUE SPECIALTIES	NORTH ADAMS, MASS.

NOTES

- PAGE 10, ITEM 170 - SAME AS S#867328-B EXCEPT WITH ONLY ONE NUT ON LONG STUD HOLDING RESISTOR. OMIT ALL OTHER HARDWARE. WEMCO TO ASSEMBLE WITH STD. HARDWARE AT ASSEMBLY.
- PAGE 10, ITEM 173 - SAME AS S#867327-B EXCEPT AS NOTED FOR ITEM 170
- PAGE 11, ITEM 188 - PER SPEC. RE-49AA-147, SHEET 5A LESS NAMEPLATE.
- PAGE 11, ITEM 193 - STRUTHERS DUNN #CXA-2119, SAME AS CX-2119 EXCEPT WITHOUT COIL SERIES RESISTOR.

P-7713794

36 SHEETS

SHEET # 36

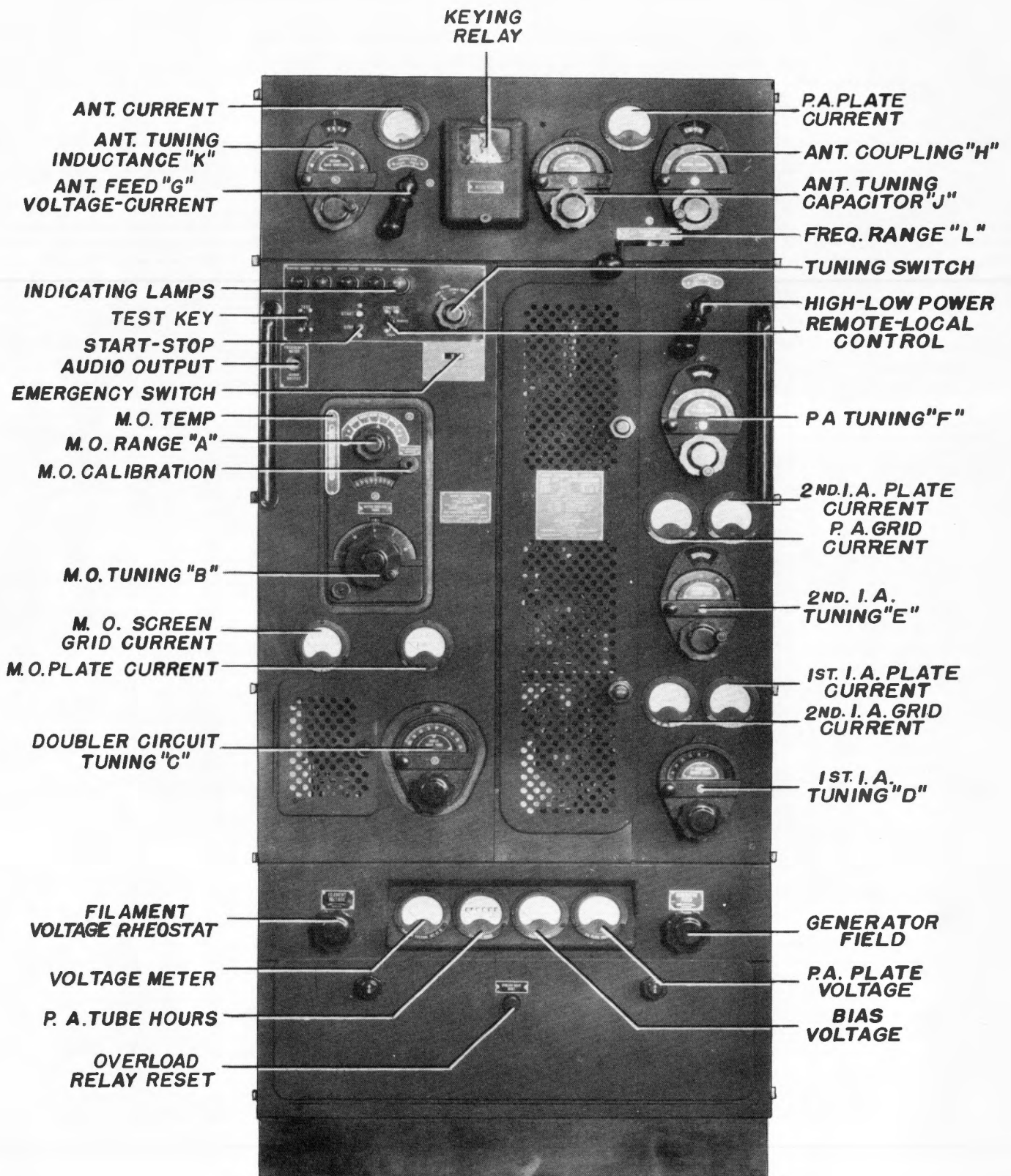
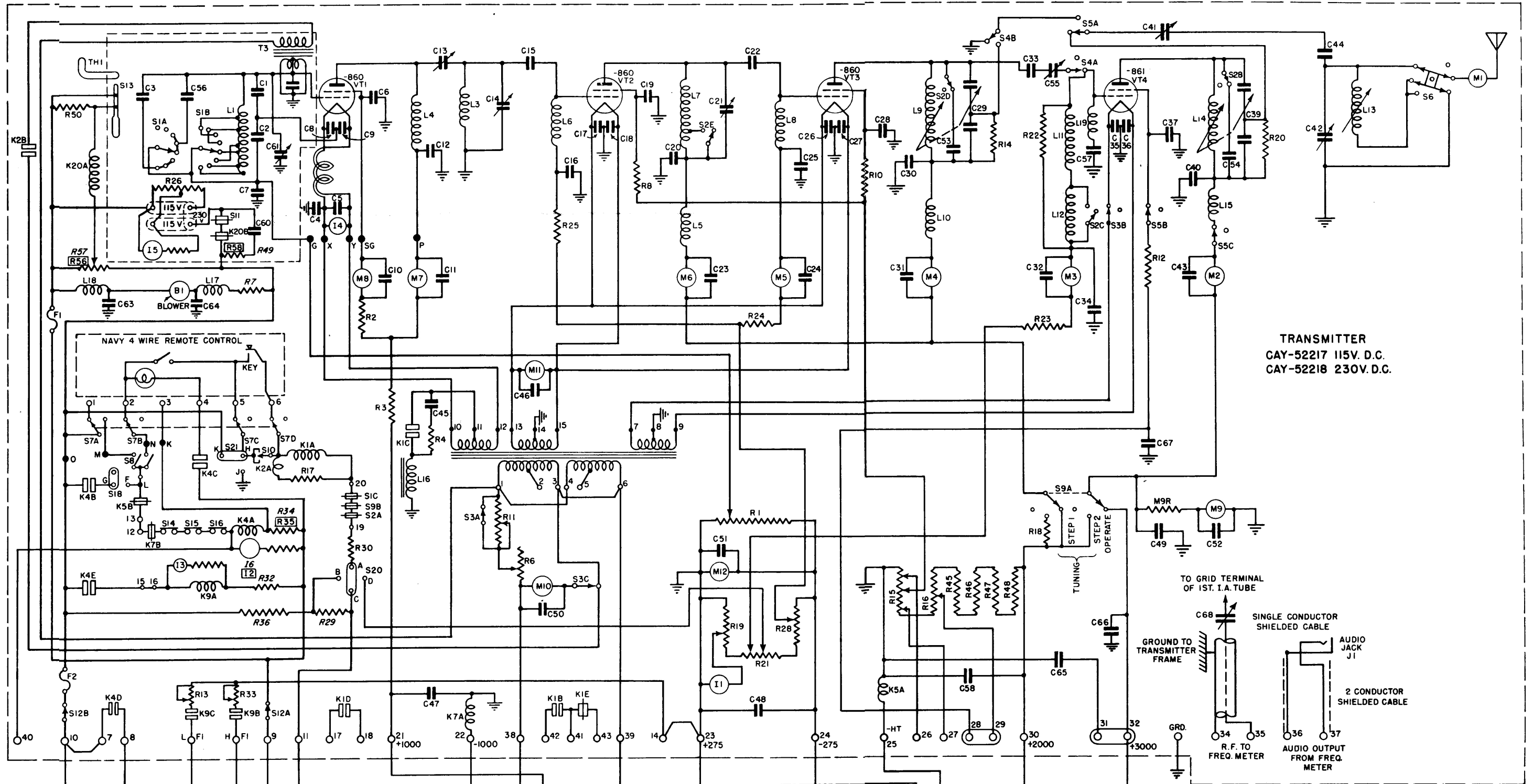
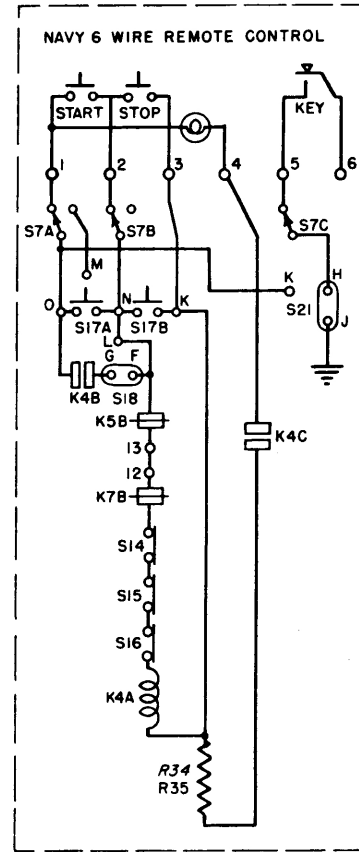

FIG. 1. TRANSMITTER UNIT TYPE CAY-52217, 115 V. D.C. OPERATION, AND TYPE CAY-52218, 230 V. D.C. OPERATION, FRONT VIEW. (Photo C-5082)



TRANSMITTER
CAY-52217 115V. D.C.
CAY-52218 230V. D.C.

CONNECTION TABLE

BEFORE INITIAL OPERATION ADJUST THE FOLLOWING CIRCUITS AS INDICATED IN THIS TABLE FOR PARTICULAR TYPE OF POWER SUPPLY AND CONTROL CIRCUITS.

ALL PARTS WITH SYMBOLS LETTERED VERTICALLY (R1) ARE FOR 115 OR 230 VOLT SUPPLY
ALL PARTS WITH SYMBOLS LETTERED SLANT (R1) ARE FOR 230 VOLTS ONLY
ALL PARTS WITH SYMBOLS LETTERED IN BOX (R1) ARE FOR 115 VOLTS ONLY

CIRCUIT	115 VOLT CONNECTION		230 VOLT CONNECTION	
	4-WIRE CONTROL	6-WIRE CONTROL	4-WIRE CONTROL	6-WIRE CONTROL
S 21	H TO K	H TO J	H TO K	H TO J
S 18	OPEN	CLOSED	OPEN	CLOSED
S 20	A TO C	A TO D	A TO B	A TO D
T 1	1 TO 5 & 2 TO 6	1 TO 5 & 2 TO 6	2 TO 5	2 TO 5
R 26	PARALLEL CONNECTION LINKS IN 115V POSITION		SERIES CONNECTION LINKS IN 230V POSITION	
R 7	USE DUMMY RESISTOR		REPLACE DUMMY WITH R 7	
R 32	USE DUMMY RESISTOR		REPLACE DUMMY WITH R 32	
R 34 R 35	USE R 35		USE R 34	
R 29 R 36	NOT USED RESISTOR POSITION LEFT BLANK		USE R 29 & R 36 IN PROPER POSITIONS	
R 56 R 57	USE R 56		USE R 57	
R 49 R 58	USE R 58		USE R 49	
I 2 I 6	USE I 2		USE I 6	
S 8 & S 19	USE S 8 & CONNECT AS FOLLOWS K BLANK L TO S 8 COMMON M TO S 8 N TO S 8 O BLANK	USE S 17 & CONNECT AS FOLLOWS K TO S 17 B L TO N M BLANK N TO S 17 A & B COMMON O TO S 17 A	SAME AS FOR 115 VOLT 4 WIRE CONTROL	SAME AS FOR 115 VOLT 6 WIRE CONTROL

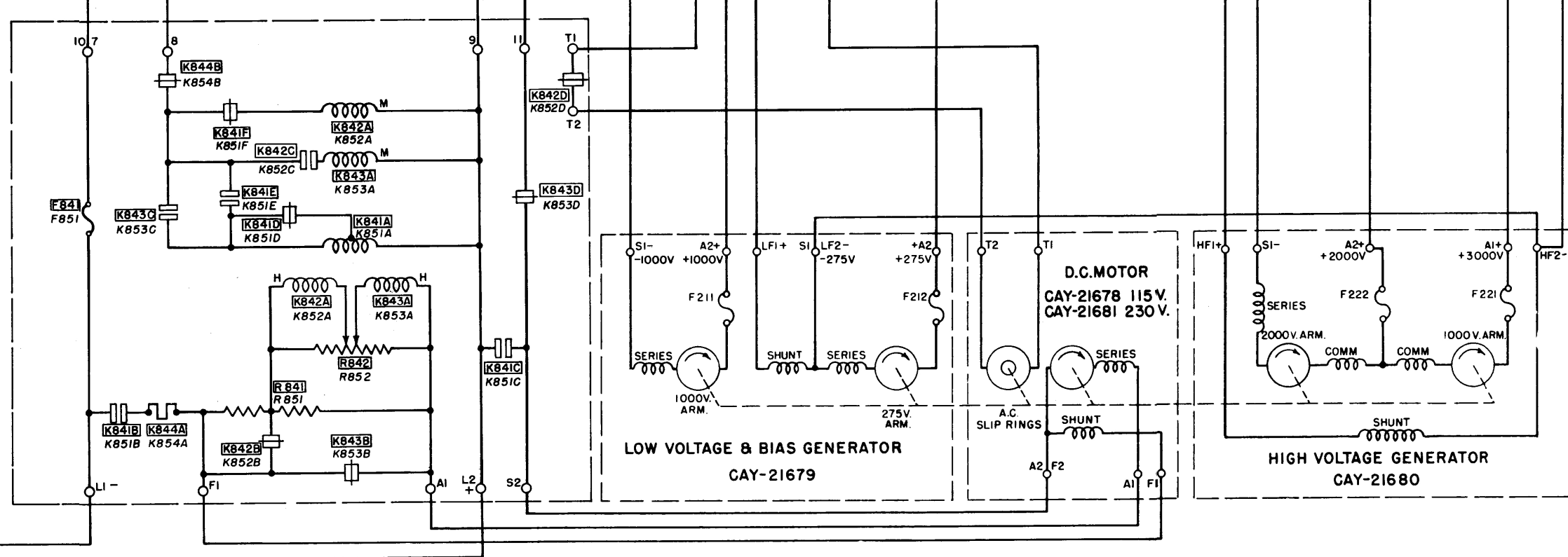

115 OR 230 VOLTS D.C.
4.5 KW

FIG. 14. SCHEMATIC DRAWING TBK-20 D.C. EQUIPMENTS SHOWING UNITS (DWG. W-7300718) 7-14

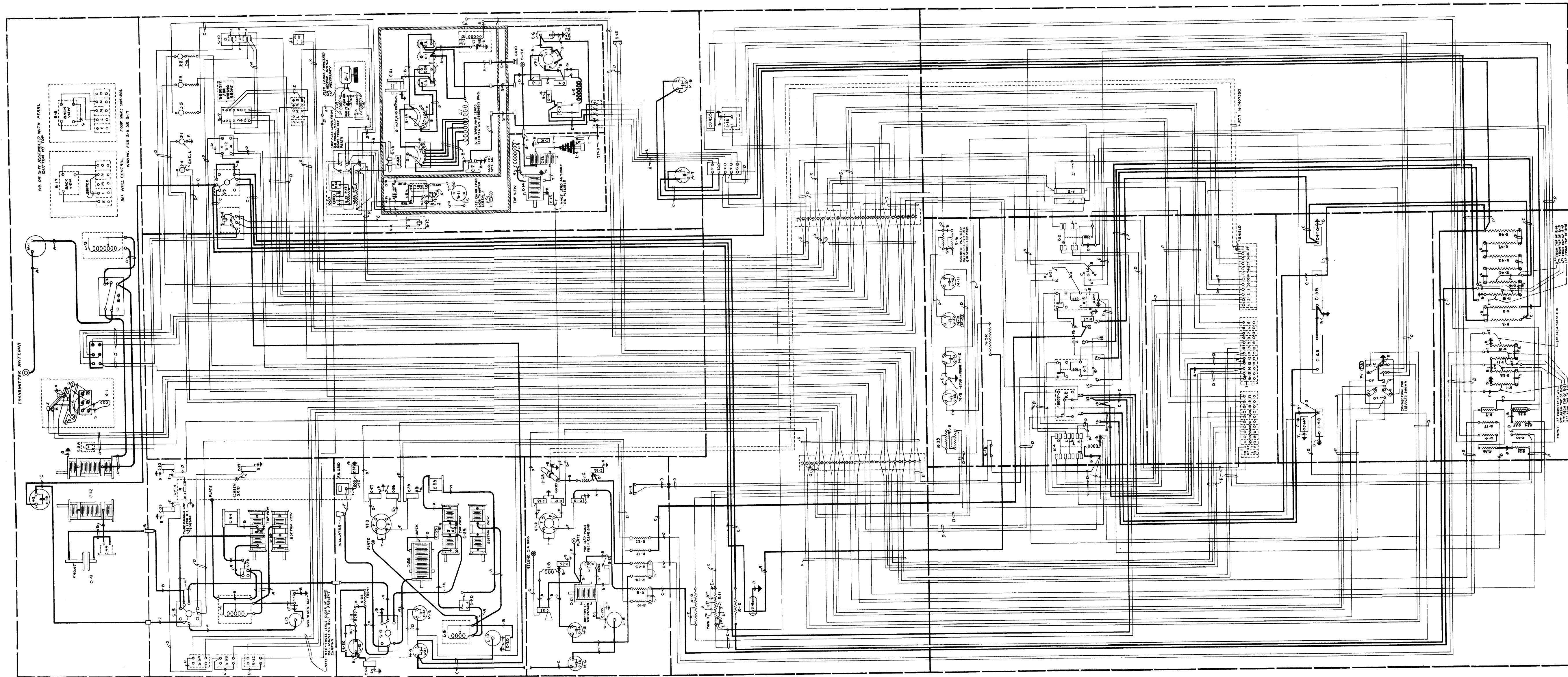

SYMBOL	PT. NO.	DESCRIPTION
A		1/8" THINNED COPPER TUBING (SEE NOTE)
B		NO. 8 THINNED BARE COPPER
C		3500 VOLT CABLE V.C.L.C. T OF 290
D		500 VOLT CABLE V.C.L.C. T OF 632
E		FLEXIBLE CABLE
F		FLEXIBLE CABLE
G		NO. 18 THINNED COPPER #2035 B BROWN
H		CABLE
I		CABLE
J		CABLE
K		CABLE
L		CABLE
M		CABLE
N		CABLE
O		CABLE
P		NO. 18 THINNED COPPER #2035 B BROWN
Q		NO. 18 THINNED COPPER #2035 B BROWN
R		NO. 18 THINNED COPPER #2035 B BROWN
S		NO. 18 THINNED COPPER #2035 B BROWN
T		NO. 18 THINNED COPPER #2035 B BROWN
U		NO. 18 THINNED COPPER #2035 B BROWN
V		NO. 18 THINNED COPPER #2035 B BROWN
W		NO. 18 THINNED COPPER #2035 B BROWN
X		NO. 18 THINNED COPPER #2035 B BROWN
Y		NO. 18 THINNED COPPER #2035 B BROWN

FOR WIRE BILL OF MATERIAL SEE DWG. 7708749

NOTE: ALL LEADS TO METER ARE TO BE LEFT LONG ENOUGH AND FLEXIBLE ENOUGH TO PERMIT REMOVAL OF THESE METERS FROM THE FRONT OF THE SET ON LEAD COVERED LEADS. LEAD A SUFFICIENT DISTANCE TO PREVENT NECESSARY PERMANENCY.

NOTE: EXTREME CARE SHOULD BE TAKEN TO BEYOND THE RUNNING OF CABLE OVER SCREENS OR OTHER SHARP PROJECTIONS TO BE COVERED WITHOUT PROPERLY PROTECTING CABLE WITH FELT OR OTHER SUITABLE MEANS.

NOTE: S-B IS SHOWN IN THE OPERATE POSITION.
NOTE: OUTSIDE TURN OF CHOICE C-12 IS SHOWN BY SOLID DOT.

NOTE: ON CONTACTOR K-19, CONTACT "B" IS NEAREST TO CONTACTOR PANEL.

NOTE: FOR 115 VOLT OPERATION R-7 AND R-32 ARE BUNNY RESISTORS.
NOTE: CIRCUIT PARTS WHOSE SYMBOLS ARE UNDEVELOPED WITH A DOTTED LINE ARE FOR 115 VOLT OPERATION ONLY. CIRCUIT PARTS WHOSE SYMBOLS ARE UNDEVELOPED WITH A SOLID LINE ARE FOR 230 VOLT OPERATION ONLY.

TRANSFORMER CONNECTIONS		
SYMBOL	115 VOLTS	230 VOLTS
T1	LINK 1 TO 5	LINK 5 TO 2
T16	AND 2 TO 6	LINK 5 TO 2
USE FOR LEADS	1 AND 6	1 AND 6

FIG. 15. WIRING DIAGRAM, TRANSMITTER UNIT, TYPE CAY-52217, 115 V. D.C. OPERATION, AND TYPE CAY-52218, 230 V. D.C. OPERATION. (DWG. W-7500446) 7-15

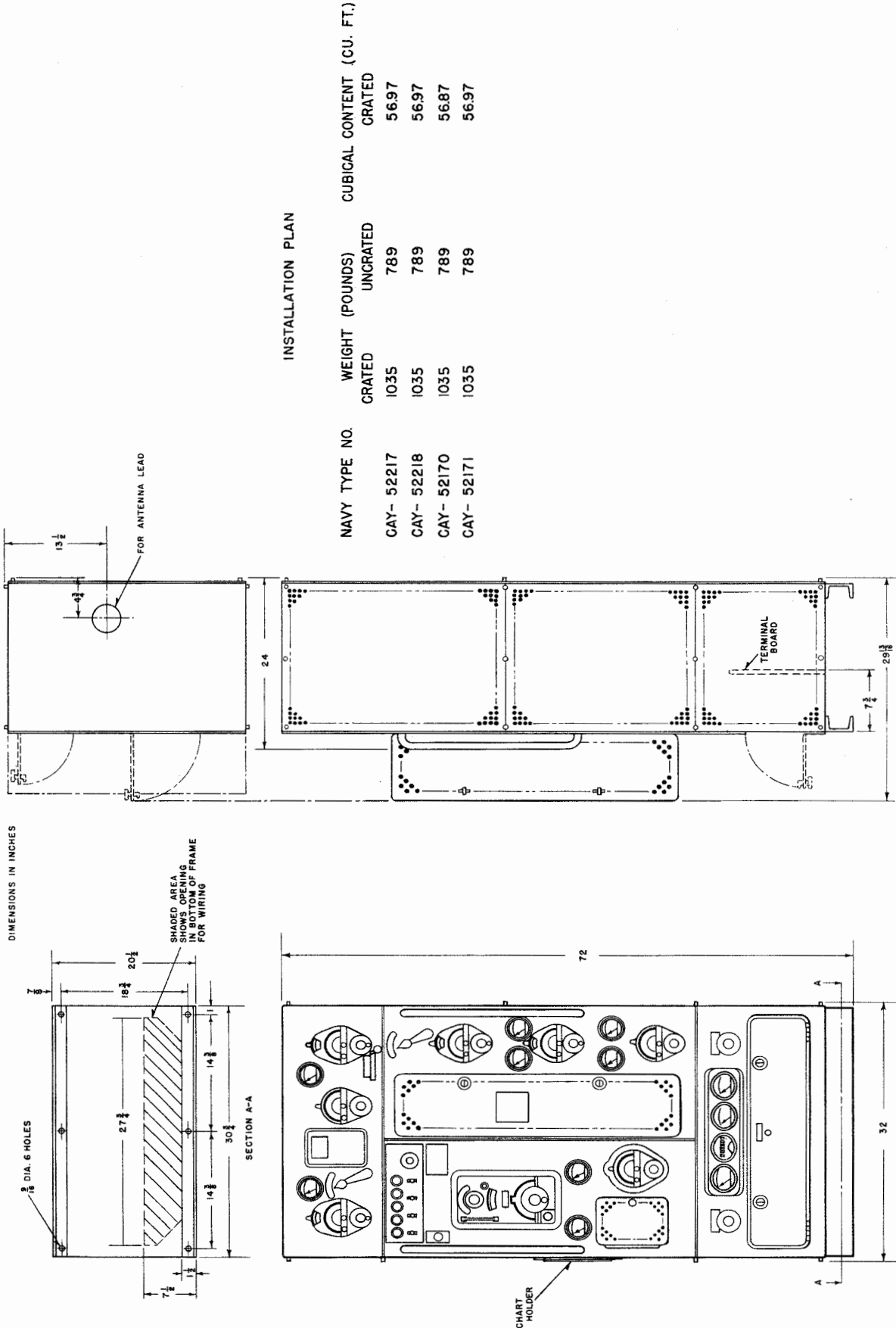
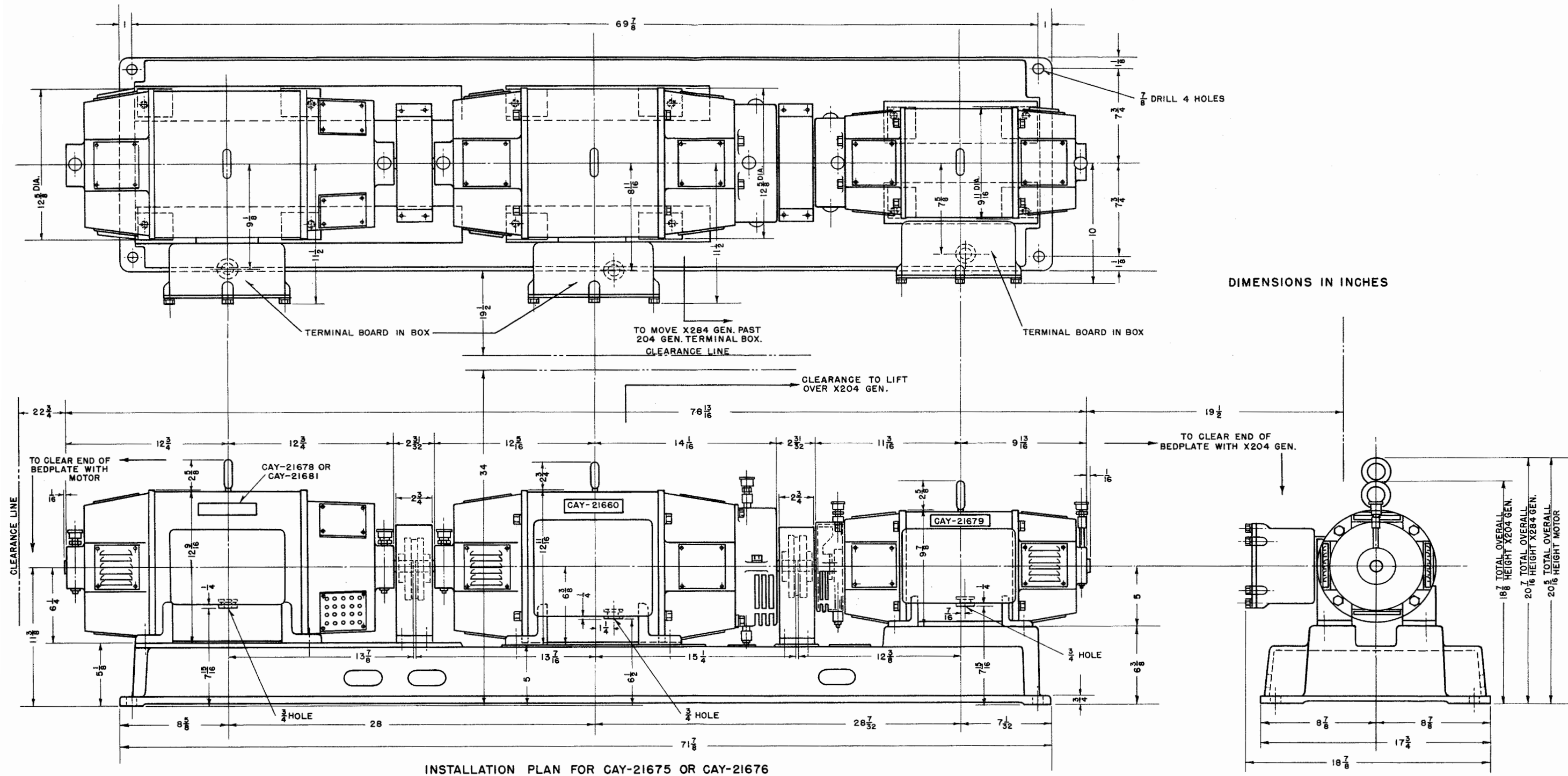

FIG. 16. OUTLINE AND MOUNTING DIMENSIONS TRANSMITTER UNIT, TYPE CAY 52217, 115 V. D.C. OPERATION, TYPE CAY-52218, 230 V. D.C. OPERATION, AND TYPE CAY-52171, 440 V., 3 PHASE, 60 CYCLE OPERATION. (Dwg. T-7611719)



INSTALLATION PLAN FOR CAY-21675 OR CAY-21676

MG SET	CONSISTING OF	WEIGHT (POUNDS)		CUBICAL CONTENT (CU. FT.)
		GRATED	UNCRATED	
CAY-21675	CAY-21678 115V D.C. MOTOR	1335	1093	2942
	CAY-21679 L.V. & BIAS D.C. GENERATOR			
	CAY-21680 H.V. D.C. GENERATOR			
CAY-21676	CAY-21681 230V D.C. MOTOR	1335	1093	2942
	CAY-21679 L.V. & BIAS D.C. GENERATOR			
	CAY-21680 H.V. D.C. GENERATOR			

NAVY TYPE CAY-21678 D.C. MOTOR SK-X259-4/2 POLE-5HP.-1800 R.P.M. 115 VOLTS 4.4 AMPS.
 NAVY TYPE CAY-21681 D.C. MOTOR SK-X254-4/2 POLE-5HP.-1800 R.P.M. 230 VOLTS 22 AMPS.
 NAVY TYPE CAY-21680 GENERATOR SK-X284-2/2 POLE-1.05/1.5 KW. 1800 R.P.M. 3000/2000 VOLTS D.C.-35/75 AMPS.
 NAVY TYPE CAY-21679 GENERATOR SK-X204-2 POLE-.075/253 KW 1800 R.P.M. 1000/275 VOLTS D.C.-075/92 AMPS.

FIG. 17. OUTLINE AND MOUNTING DIMENSIONS, MOTOR-GENERATOR SET, TYPE CAY-21676, 230 VOLT D.C. OPERATION AND MOTOR-GENERATOR SET, TYPE CAY-21675, 115 VOLT D.C. OPERATION, (DWG. T-7611738)

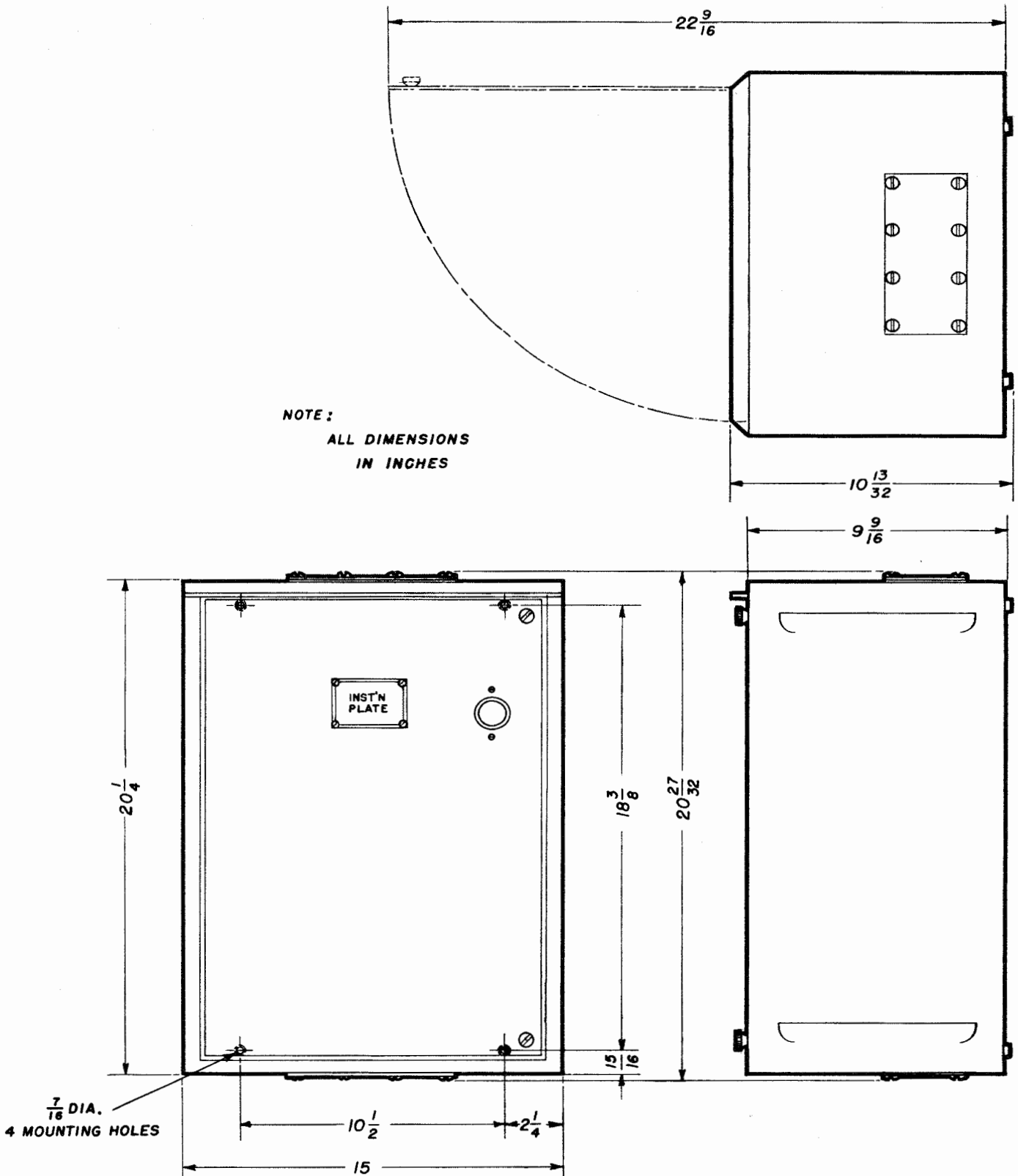

INSTALLATION PLAN

NAVY TYPE NUMBER	WEIGHT (POUNDS)		CUBICAL CONTENT (CU. FT.) CRATED
	CRATED	UNCRAVED	
CAY-211231		76	
CAY-211232		76	

FIG. 18. OUTLINE AND MOUNTING DIMENSIONS - MAGNETIC CONTROLLER UNIT, TYPE CAY-211231, 115 VOLT D.C. OPERATION AND TYPE CAY-211232, 230 VOLT D.C. OPERATION. (Dwg. P-7713319)
7-18

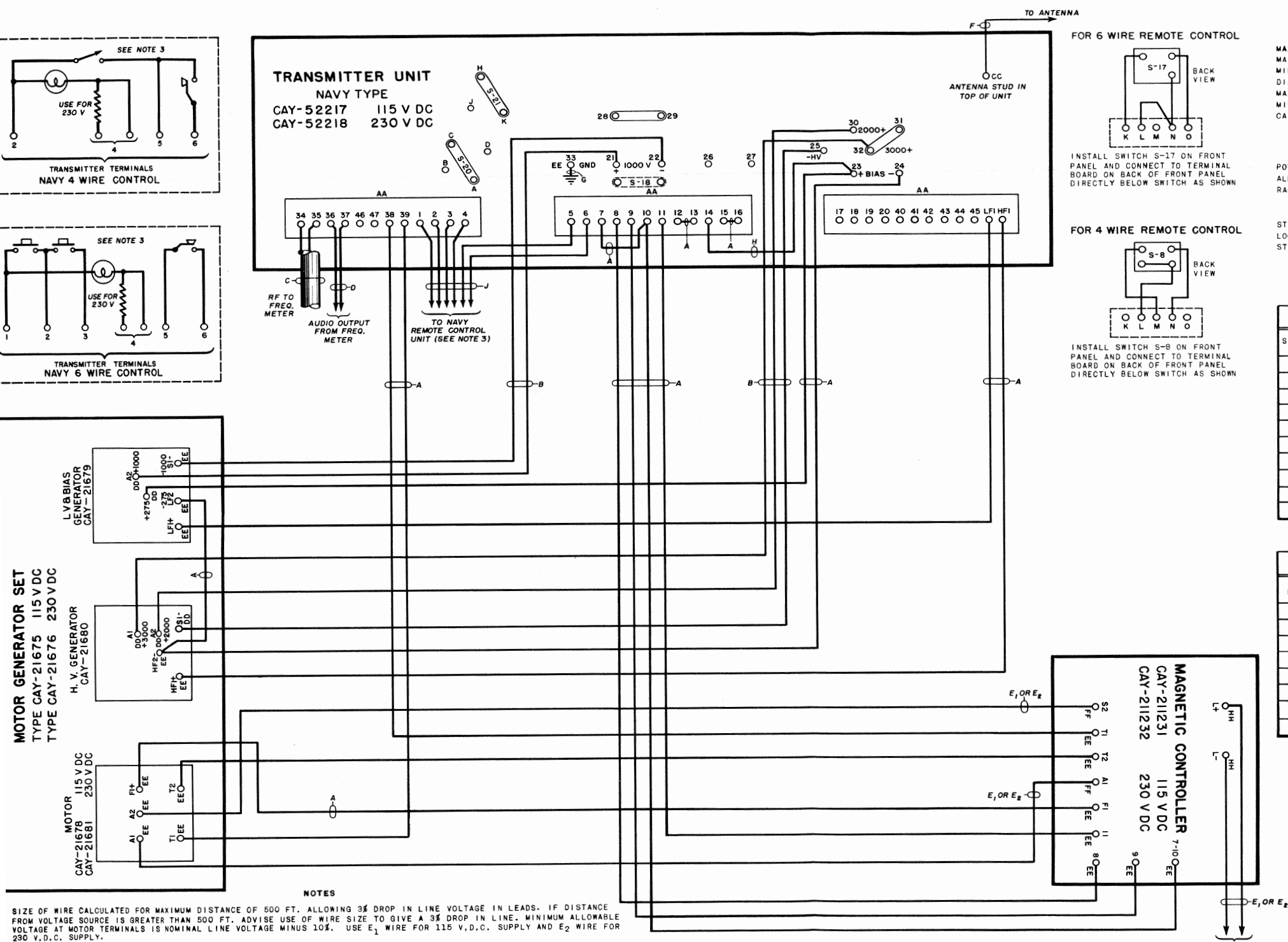

ANTENNA DATA

MAXIMUM LENGTH OF ANTENNA	80 FT.
MAXIMUM LENGTH OF TRUNK	35 FT.
MINIMUM LENGTH OF TRUNK	NONE
DIAMETER OF TRUNK	8 TO 12 INCHES
MAXIMUM DISTANCE TO ENTERING INSULATOR	20 FT.
MINIMUM DISTANCE TO ENTERING INSULATOR	2 FT.
CAPACITY	500 TO 1000 MMFD.
RESISTANCE (R.F.)	6 TO 30 OHMS

POWER REQUIREMENTS

POWER SUPPLY	115 OR 230 V.D.C.	(SEE NOTE #4)
ALLOWABLE VARIATION IN LINE VOLTAGE	10%	
RATED H.P. OF MOTOR	5 AT 1800 R.P.M.	
CONDITION	115 V. 230 V.	KILOWATTS REQUIRED FROM LINE
STARTING	8.7 4.3	10 10
LOCKED KEY	32.2 16.1	3.7 3.7
STANDBY	19.2 9.6	2.2 2.2

WIRE LEGEND

SYMBOL	CONDUCTOR SIZE CIRCULAR MILS	ALLOWABLE DROP	CURRENT RATING	VOLTAGE	TYPE INSULATION	COMMERCIAL DESIGNATION	NAVY DESIGNATION	NOTES
A	4,494		25	1000	ASBESTOS		SHFA-4	
B	4,494		25	5000	ASBESTOS		SHFR-4	
C	1,758		3	3500	SYN.RESIN		AN-RG-12/U	
D	2,828		8	1000	ASBESTOS		DHFA-3	
E ₁	49,020	3% OF LINE VOLTAGE	135	1000	ASBESTOS		DHFA-50	1
E ₂	14,350	3% OF LINE VOLTAGE	65	1000	ASBESTOS		DHFA-14	1
F	3/8" TO 1/2" DIA.				NONE			COPPER TUBING
G	1" WIDE X 1/32"TK.				NONE			SEE 6 COPPER STRAP PART OF ASSEMBLY
H								
J	2,828		8	1000	ASBESTOS		MHFA-	3

TERMINAL DESIGNATION

SYMBOL	DESCRIPTION	SIZE OF TERMINAL STUD OR SCREW	NOTES
AA	MOLDED TERMINAL STRIP	10 - 32	
BB	CERAMIC LEAD-THRU BUSHINGS IN LAMINATED PHENOLIC BOARD	10 - 32	1
CC	STUD ON STAND-OFF-INSULATOR IN TOP SECTION OF TRANSMITTER	1/4 - 20	
DD	SCREW IN EAR ON FUSE CLIP	10 - 32	
EE	STUD IN LAMINATED PHENOLIC BOARD	10 - 32	
FF	SCREW IN CONNECTION STRAP.	10 - 32	
GG	STUD IN LAMINATED PHENOLIC BOARD	1/4 - 20	
HH	CONNECTION STUD ON CONTACTOR	1/4 - 20	

CONNECTION TABLE

CIRCUIT	115 VOLT CONNECTION		230 VOLT CONNECTION	
	4-WIRE CONTROL	6-WIRE CONTROL	4-WIRE CONTROL	6-WIRE CONTROL
S 21	H TO K	H TO J	H TO K	H TO J
S 18	OPEN	CLOSED	OPEN	CLOSED
S 20	A TO C	A TO D	A TO B	A TO D
T 1	1 TO 5 & 2 TO 6	1 TO 5 & 2 TO 6	2 TO 5	2 TO 5
R 26	PARALLEL CONNECTION LINKS IN 115V. POSITION	SERIES CONNECTION LINKS IN 230V. POSITION		
R 7	USE DUMMY RESISTOR	REPLACE DUMMY WITH R7		
R 32	USE DUMMY RESISTOR	REPLACE DUMMY WITH R32		
R34 R35	USE R 35	USE R 34		
R29 R36	NOT USED RESISTOR POSITION LEFT BLANK	USE R29 & R36 IN PROPER POSITIONS		
R56 R57	USE R56	USE R57		
R49 R58	USE R58	USE R49		
I-2 I-6	USE I-2	USE I-6		
S8 & S19	USE S8 & CONNECT AS FOLLOWS K TO S8 L TO S8 COMMON M TO S8 N TO S8 O BLANK	USE S17 & CONNECT AS FOLLOWS K TO S17B L TO N M BLANK N TO S17 & B COMMON O TO S17A	SAME AS FOR 115 VOLT 4 WIRE CONTROL	SAME AS FOR 115 VOLT 6 WIRE CONTROL

NOTES

SIZE OF WIRE CALCULATED FOR MAXIMUM DISTANCE OF 500 FT. ALLOWING 3% DROP IN LINE VOLTAGE IN LEADS. IF DISTANCE FROM VOLTAGE SOURCE IS GREATER THAN 500 FT. ADVISE USE OF WIRE SIZE TO GIVE A 3% DROP IN LINE. MINIMUM ALLOWABLE VOLTAGE AT MOTOR TERMINALS IS NOMINAL LINE VOLTAGE MINUS 10%. USE E₁ WIRE FOR 115 V.D.C. SUPPLY AND E₂ WIRE FOR 230 V.D.C. SUPPLY.

TERMINALS SHOWN IN TRANSMITTER UNIT NOT MARKED WITH TERMINAL DESIGNATION SYMBOL ARE "BB" TERMINALS.

NAVY 4- OR 6- WIRE CONTROL UNITS NOT SUPPLIED ON CONTRACT AS PART OF EQUIPMENT. TYPE MHFA- WIRE FOR CONNECTION TO THESE TERMINALS SUPPLIED AS PART OF REMOTE CONTROL UNIT.

FOR 115V. D.C. SUPPLY EQUIPMENT CONSISTS OF TRANSMITTER UNIT CAY-52217, MOTOR GENERATOR SET CAY-21675, AND MAGNETIC CONTROLLER CAY-211231.

FOR 230 V.D.C. SUPPLY EQUIPMENT CONSISTS OF TRANSMITTER UNIT CAY-52218, MOTOR GENERATOR SET CAY-21676, AND MAGNETIC CONTROLLER CAY-211232.

BEFORE INITIAL OPERATION OF EQUIPMENT CONNECT CIRCUITS AS INDICATED IN CONNECTION TABLE FOR PARTICULAR TYPE OF POWER SUPPLY AND CONTROL CIRCUITS.

FRAME OF M-G SET AND CASE OF MAGNETIC CONTROLLER ARE TO BE BONDED TO TRANSMITTER FRAME BY G WIRE.

FIG. 19. INTERCONNECTION DIAGRAM, MODEL TBK-20 D.C. (DWG. T-7611742)

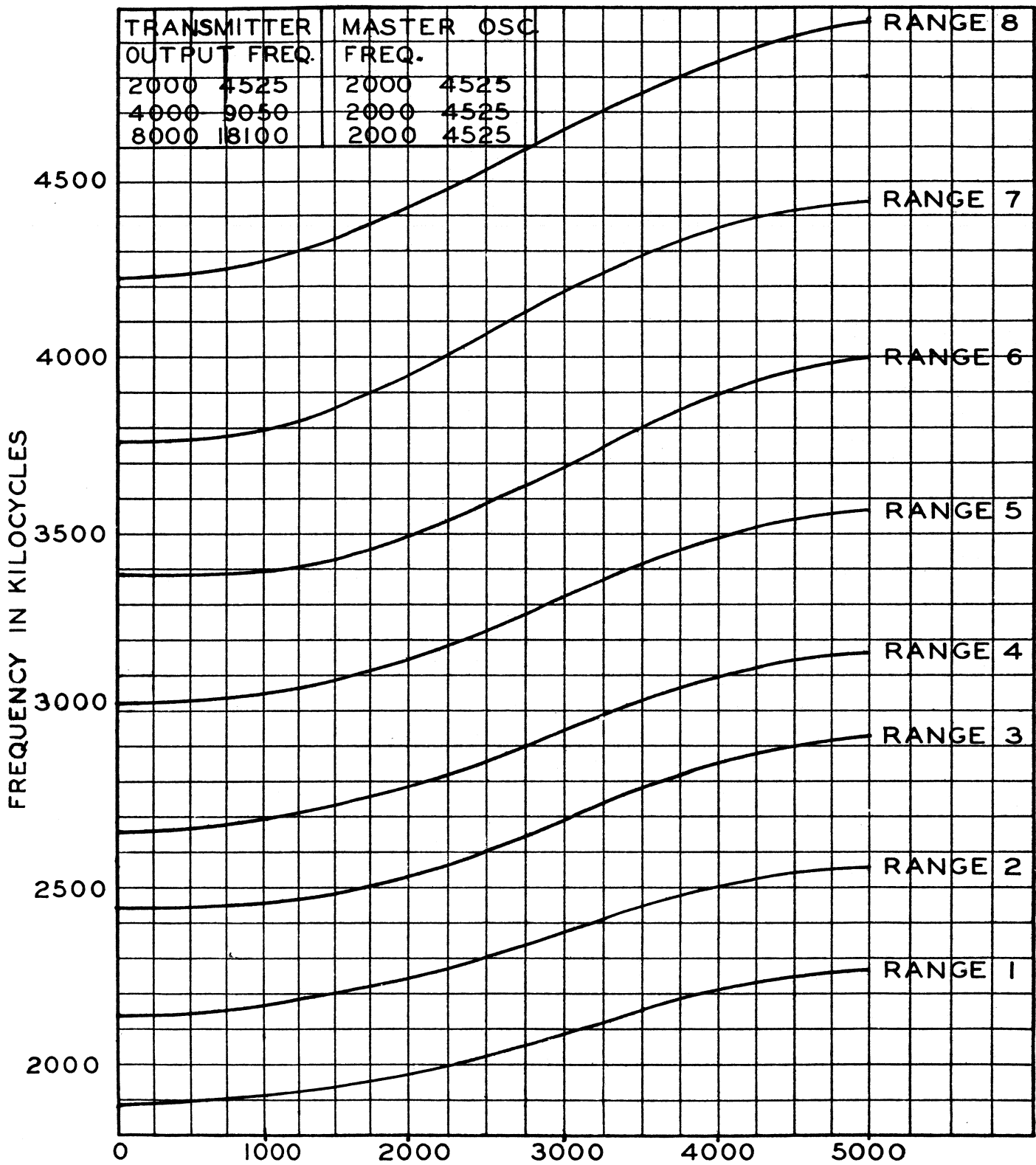

FIG. 20. TUNING CURVE FOR MASTER OSCILLATOR, CONTROLS A AND B
(Curve #226373)

TRANSMITTER OUTPUT FREQ	DOUBLER FREQ	CIR
2000-4525	2000-4525	
4000-9050	2000-4525	
8000-18100	2000-4525	

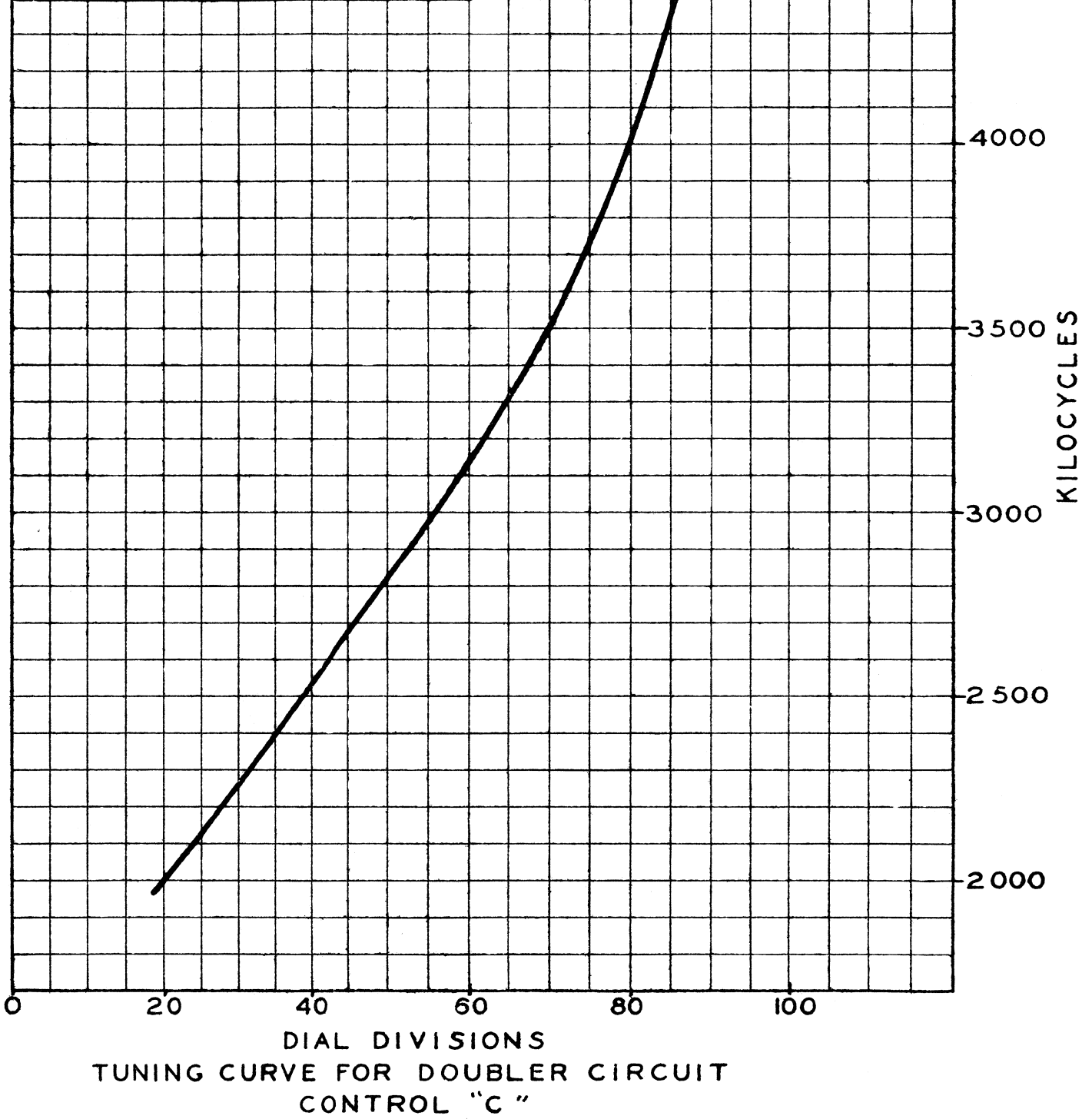

FIG. 21. TUNING CURVE FOR DOUBLER CIRCUIT - CONTROL C. (Curve #218634)

TRANSMITTER OUTPUT FREQ.	IST. INT. AMPL. FREQ.
2000 - 4000	2000 - 4000
4000 - 9050	4000 - 9050
9050 - 18100	4000 - 9050

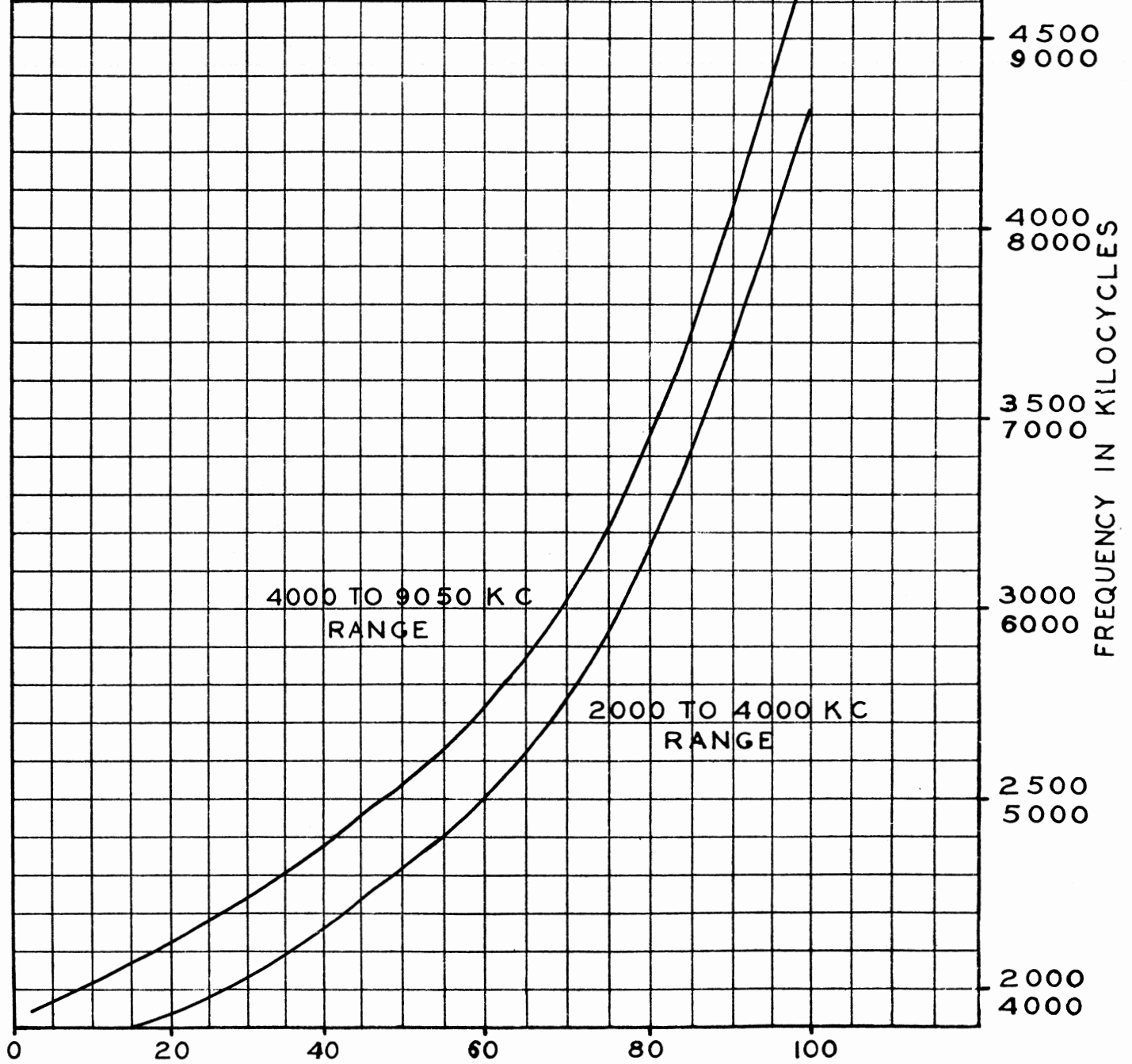

FIG. 22. TUNING CURVE FOR FIRST INTERMEDIATE AMPLIFIER CONTROL D.
(Curve #218636)

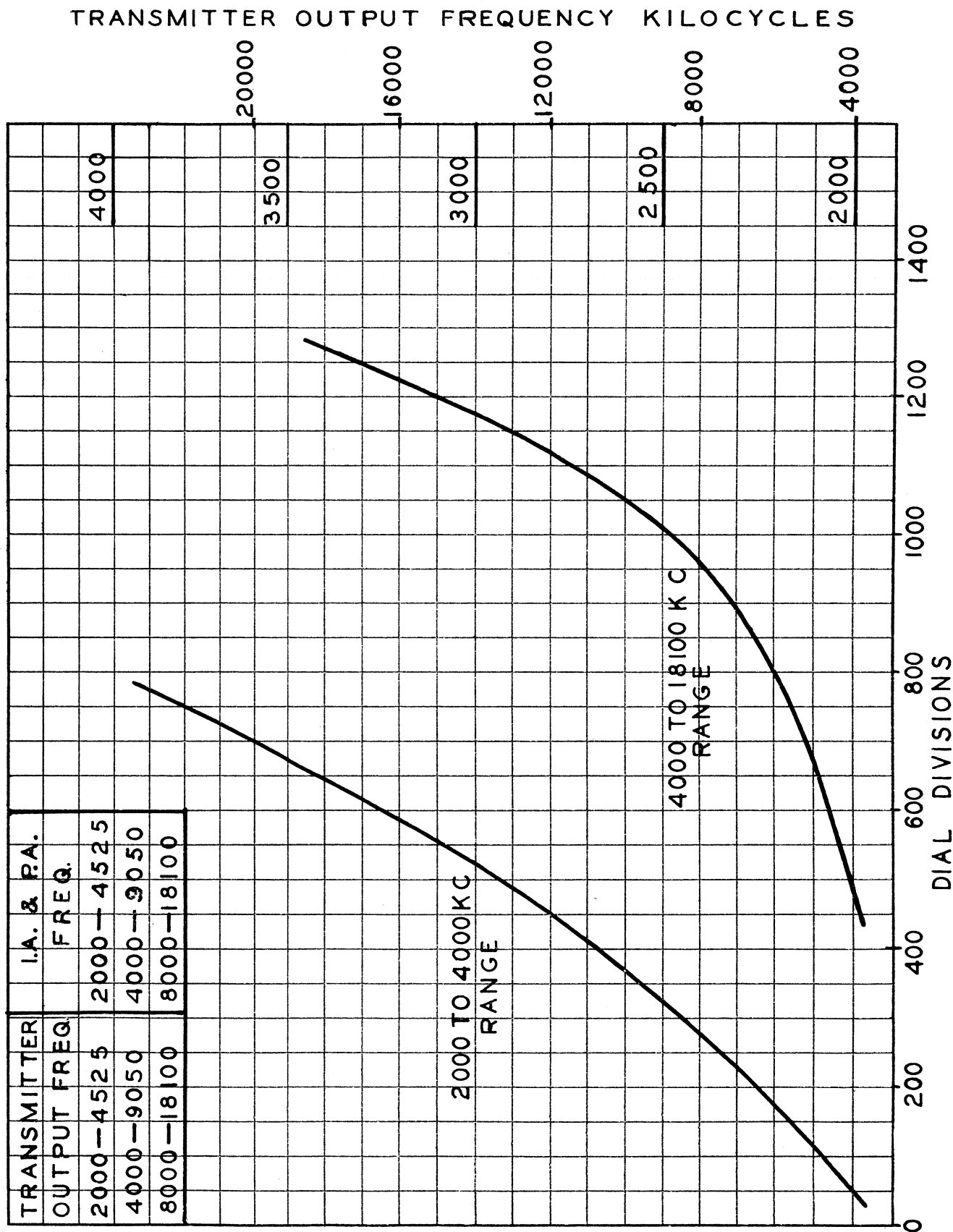
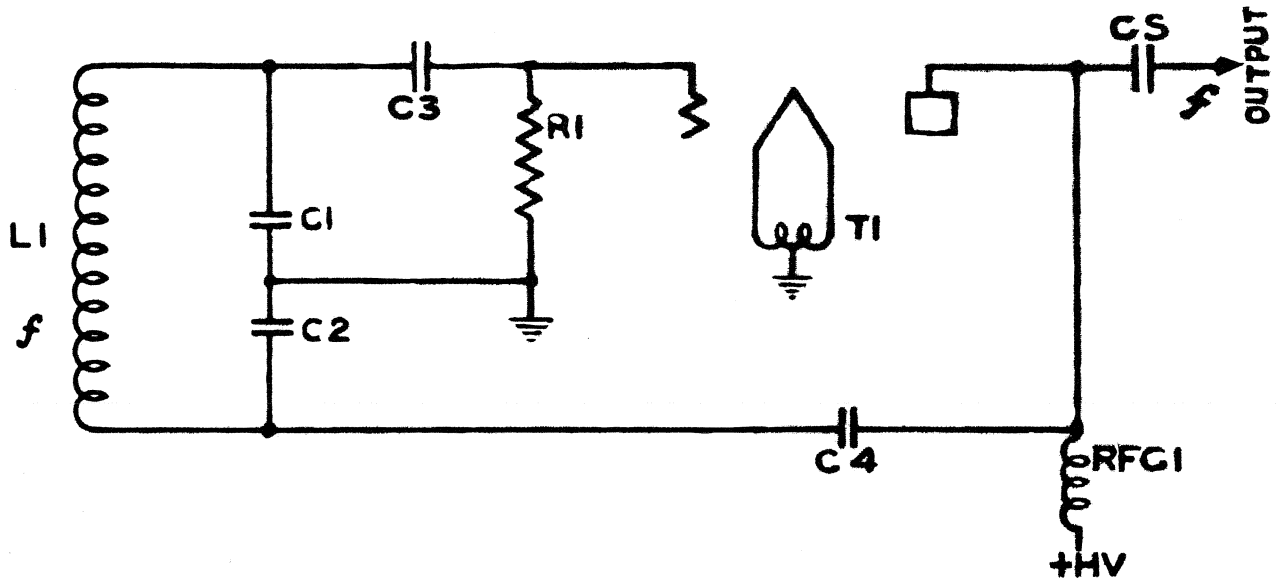
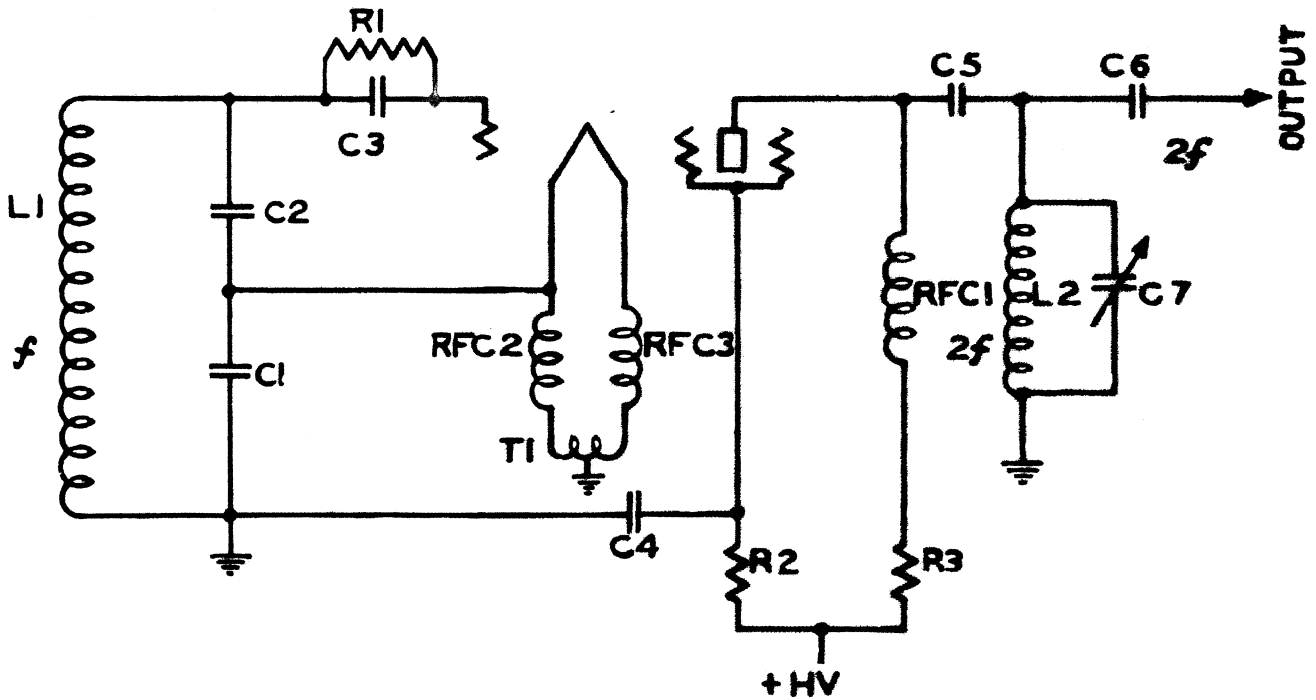

FIG. 23. TUNING CURVE FOR SECOND INTERMEDIATE AMPLIFIER AND POWER AMPLIFIERS - CONTROLS E AND F. (Curve #218635)



STANDARD COLPITTS OSCILLATOR CIRCUIT



ELECTRON COUPLED OSCILLATOR CIRCUIT

FIG. 24. STANDARD COLPITTS OSCILLATOR CIRCUIT AND ELECTRON COUPLED OSCILLATOR CIRCUIT. (Dwg.P-7705422)
7-24

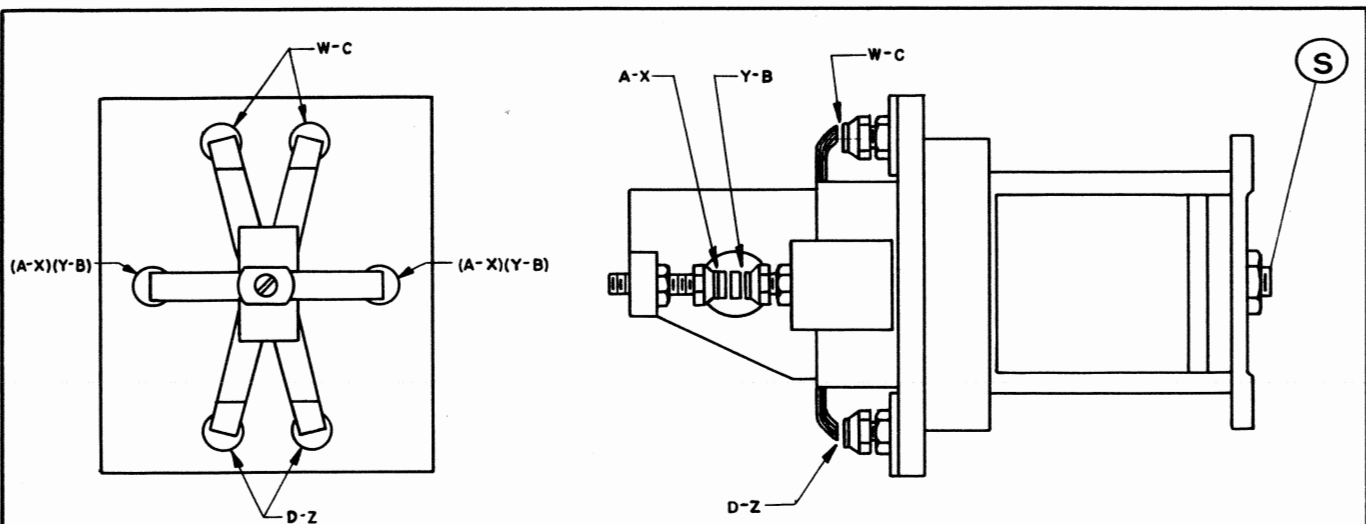

CAUTION: MAKE ALL ADJUSTMENTS BY RAISING OR LOWERING STATIONARY CONTACT STUDS. DO NOT BEND SPRING CONTACTS. A PIECE OF CROCUS CLOTH SLID BETWEEN SPRING AND STUD WILL CLEAN CONTACTS.

ADJUSTMENT PROCEDURE:

1. PRESS PLUNGER DOWN UNTIL IT BOTTOMS ON STUD. RAISE STUD (S) UNTIL BOTTOM OF INSULATOR IS .375" FROM TOP OF HEX. SHOULDER ON GUIDE PINS. (SEE NOTE BELOW)
2. RAISE PLUNGER .009 INCHES FROM BOTTOM POSITION AND ADJUST CONTACTS (W-C) TO JUST MAKE CONTACT.
3. RAISE PLUNGER AN ADDITIONAL .001 INCHES MAKING A TOTAL OF .010 INCHES FROM BOTTOM AND ADJUST CONTACTS (D-Z), (Y-B), AND (A-X) TO JUST MAKE CONTACT.
4. FINAL ADJUSTMENT IS TO BE MADE BY OBSERVING KEYING WAVE FORM ON OSCILLOGRAPH. THE CONTACTS SHALL CLOSE RELIABLY AND THERE SHALL BE NO CHATTER. REMOVE ANY SLIGHT BREAK BY SLIGHT ADJUSTMENT OF STUD (S). RELAYS WITH PLUNGERS THAT STRIKE BOTTOM ARE CONSIDERED SATISFACTORY, PROVIDED ALL OTHER REQUIREMENTS ARE MET.

NOTE: ON OLD MODELS WHERE ADJUSTABLE STUDS (S) WERE NOT PROVIDED, STRETCHING SPRINGS (DWG. 7604741, PT. 15) IS PERMISSABLE TO REMOVE BOUNCE. WHEN ADJUSTING THESE, OMIT STEP 1.

5. AFTER ADJUSTMENT, CHECK ALL LOCKNUTS AND MAKE CERTAIN THEY ARE TIGHT BEFORE REASSEMBLY OF RELAY IN EQUIPMENT.

FIG. 25. KEYING RELAY CONTACT ADJUSTMENT. (Dwg. P-7711743)
7-25

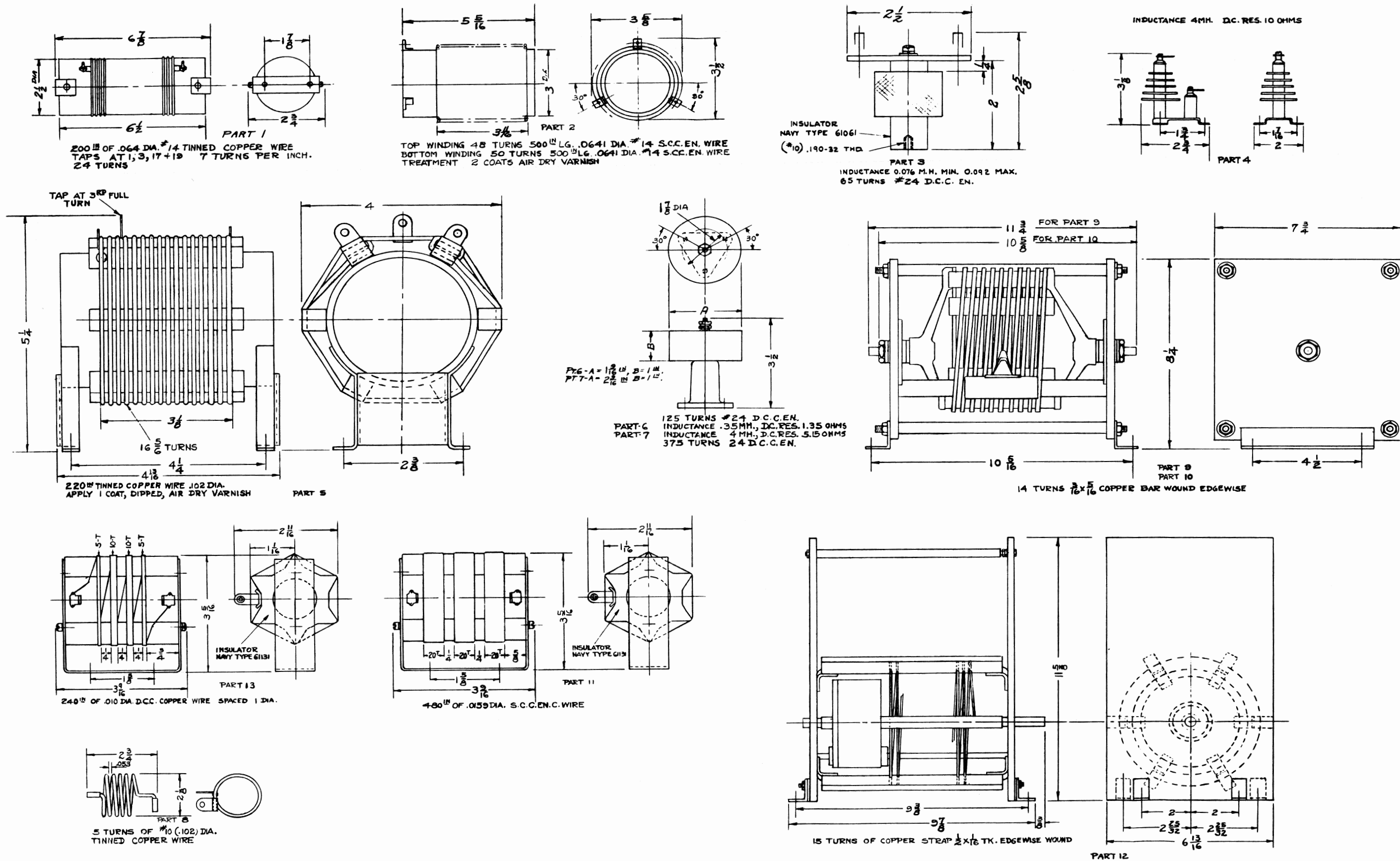

FIG. 26. DIMENSIONAL DRAWINGS AND WINDING DATA ON TUNING COILS AND VARIOMETER. (Dwg. T-7607966)

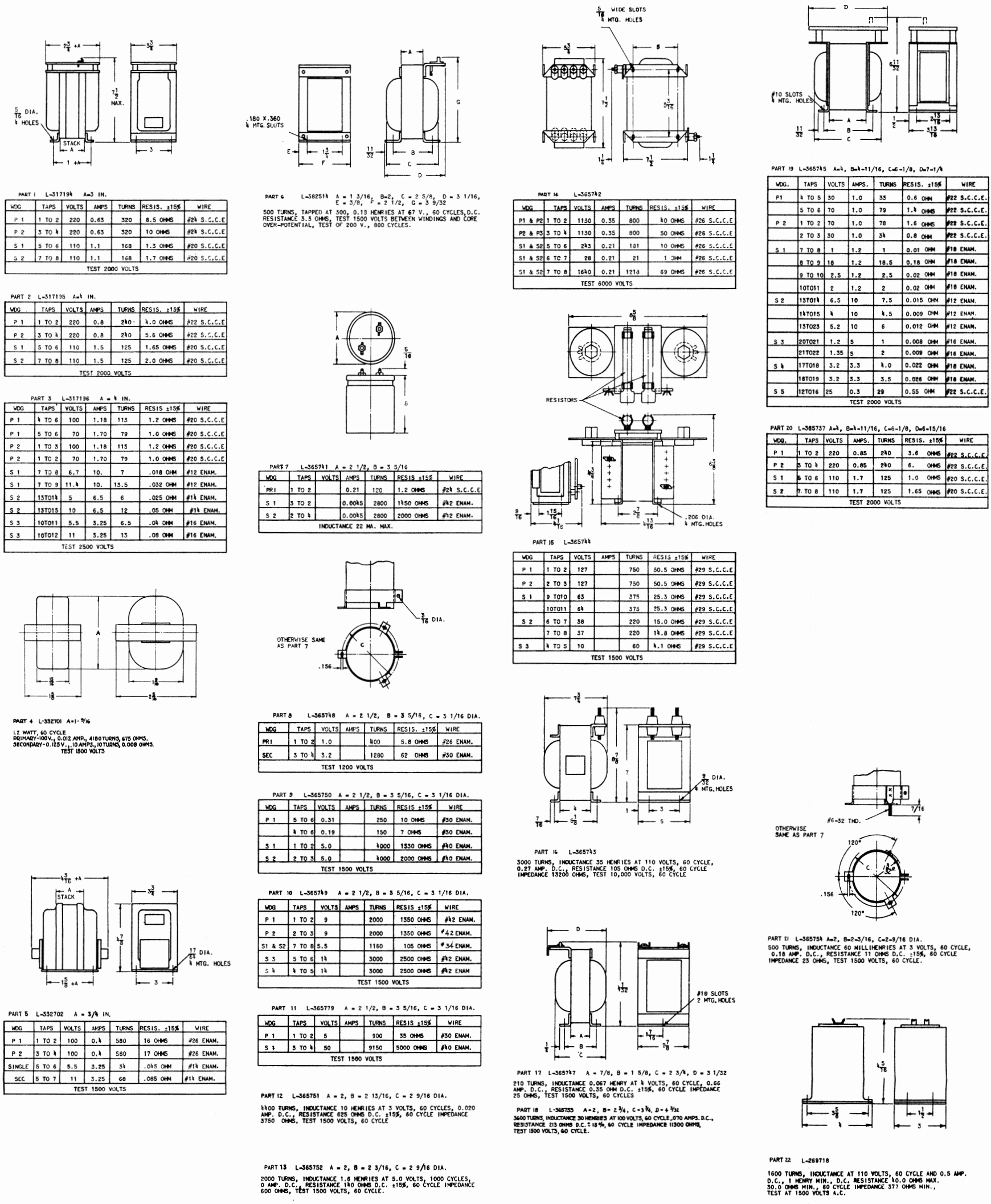

FIG. 27. DIMENSIONAL DRAWINGS AND WINDING DATA OF TRANSFORMERS AND REACTORS. (Dwg. T-7607964 and T-7607965)

7-27

CONTACTOR AND RELAY OPERATING TABLE
FOR TRANSMITTERS TYPE CAY-52217 AND CAY-52218

FIG. 28

RELAY OR CONTACTOR NUMBER	NAME	OIL FILLED	TRIP CURRENT	NORMAL OPERATION	REMARKS
K- 1	Keying	No	100 M A.	
K- 2	Compensator	No	10 M.A.	
K- 4	Starting	No	*	115-230 V.D.C. only
K- 5	H.V. Overload	No	*	Instantaneous
K- 7	M.O. Overload	No	*	Instantaneous
K- 9	Field	No	*	115-230 V.D.C. only
K-20	Thermostat	No	10 M.A.	115-230 V.D.C. only

*To be filled in later.

7-28

Navy Model TBK-20—Radio Transmitting Equipment

**CONTACTOR AND RELAY OPERATING TABLE
FOR MAGNETIC CONTROLLERS TYPES CAY-211231, CAY-211232**

FIG. 29

RELAY OR CONTACTOR NUMBER	NAME	OIL FILLED	TRIP CURRENT	NORMAL OPERATION	REMARKS
K-851	Contactator	No	*	230 V.D.C. only
K-852	Accelerating Contactator Main Coil	No	*	230 V.D.C. only
	Accelerating Contactator Holding Coil	No	*	230 V.D.C. only
K-853	Accelerating Contactator Main Coil	No	*	230 V.D.C. only
	Accelerating Contactator Holding Coil	No	*	230 V.D.C. only
K-854	Overload Relay	No	*	230 V.D.C. only
K-841	Contactator	No	*	115 V.D.C. only
K-842	Accelerating Contactator Main Coil	No	*	115 V.D.C. only
	Accelerating Contactator Holding Coil	No	*	115 V.D.C. only
K-843	Accelerating Contactator Main Coil	No	*	115 V.D.C. only
	Accelerating Contactator Holding Coil	No	*	115 V.D.C. only
K-844	Overload Relay	No	*	115 V.D.C. only

*To be filled in later.

7-29

Navy Model TBK-20—Radio Transmitting Equipment

TABLE OF TYPICAL DIAL AND TAP SETTINGS

FIG. 30

FREQ. Kcs.	POWER RANGE	ANTENNA CONSTANTS	A	B	C	D	E	F	G	H	J	K	L
2000	High	C = 1000 R = 6.098	1	2081	18	26	053	059	Curr.	975	15	0	2000
	Low	1000 6.098	1	2081	18	26	019	Curr.	776	13	0	
3000	High	Inf. 29.18	4	3313	54	76	517	511	Volt	1409	26	080	4000
3500	High	Inf. 18.98	6	2313	68	87	661	652	Volt	1463	36	080	Type C
4000	High	110 V.—500 W. Lamp	7	2235	78	08	483	473	Curr.	1017	93	600	
	Low	32 V.— 75 W. Lamp	7	2235	78	08	413	Curr.	590	85	600	
4500	High	110 V.—500 W. Lamp	8	2342	87	31	587	565	Curr.	977	100	700	4000
6000	High	110 V.—500 W. Lamp	4	3313	54	68	787	769	Curr.	1245	100	1100	
	Low	32 V.— 75 W. Lamp	4	3313	54	68	769	Curr.	785	81	1100	
7500	High	110 V.—500 W. Lamp	6	3282	73	85	909	889	Volt	1320	60	890	4000
	Low	32 V.— 75 W. Lamp	6	3282	73	85	897	Volt	878	39	890	
9050	High	110 V.—500 W. Lamp	8	2467	87	95	995	972	Volt	946	85	915	18100
	Low	32 V.— 75 W. Lamp	8	2467	87	95	983	Volt	654	70	915	
12000	High	110 V.—500 W. Lamp	4	3313	54	68	1099	1074	Volt	567	83	1205	18100
16000	High	110 V.—500 W. Lamp	7	2235	78	89	1191	1165	Volt	286	84	1384	
18100	High	110 V.—500 W. Lamp	8	2467	87	95	1233	1209	Curr.	1352	100	1120	

7-30

Navy Model T BK-20—Radio Transmitting Equipment

TABLE OF TYPICAL METER READINGS

FIG. 31

FREQ. Kcs.	POWER RANGE	ANTENNA CONSTANTS	M I _{SG} M. A.	O I _P M. A.	1ST I. A. I _P M. A.	2ND I. A. I _G M. A.	2ND I. A. I _P M. A.	P. A.		VOLTAGES			ANTENNA			
								I _G M. A.	I _P M. A.	E _P V.	E _G V.	E _f A. C. V.	I. INT. AMP.	I. EXT. AMP.	WATTS	GUAR. WATTS
2000	High	C = 1000 R = 6.098	14.5	49	38	25	61	71	350	2930	246	10	10.0	9.9	598	500
	Low	1000 6.098	14.5	49	53	33	150	3040	240	10	4.8	4.78	138	75
3000	High	Inf. 29.18	10.5	63	59	41	87	37	350	2910	242	10	4.2	4.7	645	500
3500	High	Inf. 18.98	9	63	58	44	88	27	350	2910	240	10	4.8	5.2	514	475
		Type C														
4000	High	110 V.—500 W. Lamp	9	74	66	27	48	52	350	2910	243	10	560	475
	Low	32 V.—75 W. Lamp	9	75	88	22	125	3020	240	10	120	75
4500	High	110 V.—500 W. Lamp	9	72	67	28	79	59	350	2910	243	10	610	450
6000	High	110 V.—500 W. Lamp	10	62	63	24	72	37	350	2890	239	10	540	450
	Low	32 V.—75 W. Lamp	10.5	62	79	25	125	3030	237	10	120	75
7500	High	110 V.—500 W. Lamp	9	73	76	39	96	34	350	2910	238	10	515	400
	Low	32 V.—75 W. Lamp	9	74	88	30	125	3020	236	10	120	65
9050	High	110 V.—500 W. Lamp	9	71	70	29	87	31	350	2990	238	10	490	375
	Low	32 V.—75 W. Lamp	9	72	80	28	125	3010	236	10	120	60
12000	High	110 V.—500 W. Lamp	10.5	63	60	20	68	38	350	2890	240	10	480	360
16000	High	110 V.—500 W. Lamp	9	72	65	26	83	47	350	2890	241	10	375	325
18100	High	110 V.—500 W. Lamp	8.5	72	60	24	90	44	350	2890	239	10	340	300

7-31

Navy Model TBK-20—Radio Transmitting Equipment

VIII. Vacuum Tube Data

A. General

8-1 ALL TUBES SUPPLIED WITH THE EQUIPMENT OR AS SPARES ON THE EQUIPMENT CONTRACT SHALL BE USED IN THE EQUIPMENT PRIOR TO EMPLOYMENT OF TUBES FROM GENERAL STOCK.

8-2 NOTE: The Type 860 tubes used in the master oscillator circuit of the transmitter unit should be of the anchored filament type, filament supported top and bottom in such a manner as to prevent contact variation and resultant variation in emitted signal. The use of an unanchored filament type tube may cause unstable operation of the Transmitter. The anchored type of filament may usually be recognized by the color of the filament turn which wraps around the center support. When the tube is operated at normal voltage this turn on the anchored type will be cold whereas on the unanchored type this turn will glow.

8-3 NOTE: With respect to the Type 861 tube used in the power amplifier, it is desirable that the filament support rod be electrically connected to the filament. With tubes of Westinghouse manufacture having serial numbers 27200 or above, this connection is accomplished through resistors located in the base of the tube. Equivalent construction is employed also by other manufacturers.

8-4 THE TYPE 860 TUBE AND THE TYPE 861 TUBE MUST BE OPERATED WITH AN AVERAGE FILAMENT VOLTAGE EQUAL TO THE RATED VALUE AND THE VARIATION OF THIS VOLTAGE SHOULD BE WITHIN PLUS OR MINUS 5%. THE USE OF FILAMENT VOLTAGE LESS THAN THAT RECOMMENDED WILL IN TIME RESULT IN LOSS OF EMISSION DUE TO TOO LOW A RATE OF DIFFUSION OF THE ACTIVE MATERIAL TO THE FILAMENT SURFACE. MORE THAN RATED VOLTAGE WILL SHORTEN THE LIFE OF THE TUBE BY TOO RAPID EVAPORATION OF THE ACTIVE MATERIAL FROM THE FILAMENT SURFACES. DURING STANDBY PERIODS, THE FILAMENT VOLTAGE SHOULD BE MAINTAINED AT THE RATED VALUE.

8-5 A total of four vacuum tubes, three Type 860, and one Type 861, are used in the Radio Transmitter Unit.

8-6 The Type 860 tube is a four element or screen grid tube designed for use as an oscillator or power amplifier in transmitting circuits. It has a rated output of 75 watts at 2000 volts potential. The filament requires 3.25 amperes at 10 volts which should not fluctuate more than 5% from the rated value. Under normal operating conditions, the plate dissipation should never exceed 100 watts. The screen grid requires very little power for proper functioning and, therefore, its potential should be kept at as low a value as possible. The total dissipation on this grid should never exceed 10 watts.

8-7 The Type 861 tube is similar to the Type 860 except that it has a rated output of 500 watts at 3000 volts plate potential. Its filament requires 10 amperes at a potential of 11 volts which should not fluctuate more than 5% from the rated value. Its normal plate dissipation is 400 watts and its screen grid dissipation should never exceed 35 watts. Both the Type 860 and the Type 861 vacuum tubes are made with thoriated filaments which provide a large filament emission at low temperatures. In order to obtain satisfactory tube life these tubes should be handled with extreme care as they may be permanently injured if subjected to sudden shocks. They should never be operated above their rating and when not installed in the transmitter unit should always be well secured and stowed in their original containers in an upright position.

8-8 In cases of severe overload resulting in the overheating of the tube, the electron emission may be very slight or may be reduced to a point where oscillations will not start. Unless the overload has liberated a large amount of gas, the activity of the filament can usually be restored by operating the tube at normal filament potential for ten minutes or longer with the plate potential off. This reactivating process can be accelerated by raising the filament potential to 12 volts but no higher. The useful life of all thoriated filament tubes is usually ended long before the filament burns out. If a tube loses its emission and cannot be reactivated within a reason-

able length of time by the method described above, it should be replaced by a new tube.

8-9 When placing a thoriated tube in operation for the first time, it is desirable to operate the filament from five to ten minutes before plate power is applied. This serves a two-fold purpose. The hot filament tends to absorb any traces of gas that may be present in the tube and also permits the active material in the filament to diffuse to the surface of the filament.

8-10 Ordinary care in the handling and use of tubes will minimize accidental damage to the tubes. The tubes should be handled carefully and should

not be allowed to snap into position when being placed in the socket. In all cases, regardless of the use to which the tubes are put, careful handling and conservative operation will be amply repaid by the longer and more uniform tube life which will be obtained.

8-11 The following tabulation compares the actual operating condition of the tubes as used in the Radio Transmitting Unit with the ratings listed in the Navy Tube Specifications. CAUTION: Except where indicating instruments are already incorporated in the equipment, operating personnel should not attempt to measure potentials in excess of 500 volts within the equipment due to hazards to life.

B.

MASTER OSCILLATOR TUBE, TYPE 860

	FULL LOAD OPERATING DATA	MAXIMUM RATING LISTED IN RE-13A-600A	AMOUNT BY WHICH RATING IS EXCEEDED
A.C. Filament Voltage	10 Volts	10 Volts	None
D.C. Plate Voltage	700 Volts	3000 Volts	None
D.C. Plate Current	60 Ma.	150 Ma.	None
D.C. Grid Voltage	-100 Volts	... Volts	None
D.C. Grid Current	10 Ma.	40 Ma.	None
R.F. Grid Current	0.050 Amps.	10 Amps.	None
Plate Dissipation	20 Watts	100 Watts	None
Plate Power Input	42 Watts	300 Watts	None
Screen Input	6 Watts	10 Watts	None
Screen Voltage	300 Volts	... Volts	None

8-3

C.

FIRST INTERMEDIATE AMPLIFIER TUBE, TYPE 860

A.C. Filament Voltage	10 Volts	10 Volts	None
D.C. Plate Voltage	2000 Volts	3000 Volts	None
D.C. Plate Current	88 Ma.	150 Ma.	None
D.C. Grid Voltage	-200 Volts	... Volts	None
D.C. Grid Current	15 Ma.	40 Ma.	None
R.F. Grid Current	0.10 Amp.	10 Amp.	None
Plate Dissipation	75 Watts	100 Watts	None
Plate Power Input	176 Watts	300 Watts	None
Screen Input	6 Watts	10 Watts	None
Screen Voltage	275 Volts	... Volts	None

D.

SECOND INTERMEDIATE AMPLIFIER TUBE, TYPE 860

	FULL LOAD OPERATING DATA	MAXIMUM RATING LISTED IN RE-13A-600A	AMOUNT BY WHICH RATING IS EXCEEDED
A.C. Filament Voltage	10 Volts	10 Volts	None
D.C. Plate Voltage	2000 Volts	3000 Volts	None
D.C. Plate Current	150 Ma.	150 Ma.	None
D.C. Grid Voltage	-200 Volts	... Volts	None
D.C. Grid Current	40 Ma.	40 Ma.	None
R.F. Grid Current	0.250 Amps.	10 Amps.	None
Plate Dissipation	100 Watts	100 Watts	None
Plate Power Input	300 Watts	300 Watts	None
Screen Input	8 Watts	10 Watts	None
Screen Voltage	250 Volts	... Volts	None

8-4

E.

POWER AMPLIFIER TUBE, TYPE 861

A.C. Filament Voltage	11 Volts	11 Volts	None
D.C. Plate Voltage	3000 Volts	3500 Volts	None
D.C. Plate Current	350 Ma.	350 Ma.	None
D.C. Grid Voltage	-250 Volts	... Volts	None
D.C. Grid Current	75 Ma.	75 Ma.	None
R.F. Grid Current	1.5 Amp.	10 Amp.	None
Plate Dissipation	350 Watts	400 Watts	None
Plate Power Input	1050 Watts	1200 Watts	None
Screen Input	20 Watts	35 Watts	None
Screen Voltage	460 Volts	... Volts	None