

Temporary Change T-1 to Technical Manual for AN/SRT-14,-15, and 16, NAVSHIPS 0967-970-3010 (Formerly NAVSHIPS 92121A).

This Temporary Change contains information originally published as separate articles (Technical Manual Corrections) in the Electronics Information Bulletin, (EIB), numbers: 739.

The instructions, described herein, for making these changes shall be followed only if they have not been previously accomplished at the time the EIB, in which the information appeared, was received.

The purpose of this Temporary Change is to assure that publications drawn from stock, subsequent to publication of this information in the EIB, can be corrected.

Insert this Temporary Change in the technical manual immediately behind the front cover and preceding the title page or preceding the latest change or correction in effect.

Make pen-and-ink corrections or changes to the technical manual as follows:

As a result of standardization actions, the double scale meter for symbol M-1301 has been superseded by a meter with a single scale, FSN-1N6625-764-8225. On page 8-75, table 8-3, under M-1301, make the following corrections. Change JAN type MR35W106SPEC to read:

"JAN type MR36W106SPECR, FSN 1M6625-764-8225"

☆U.S. GOVERNMENT PRINTING OFFICE: 1973-714-438/5388

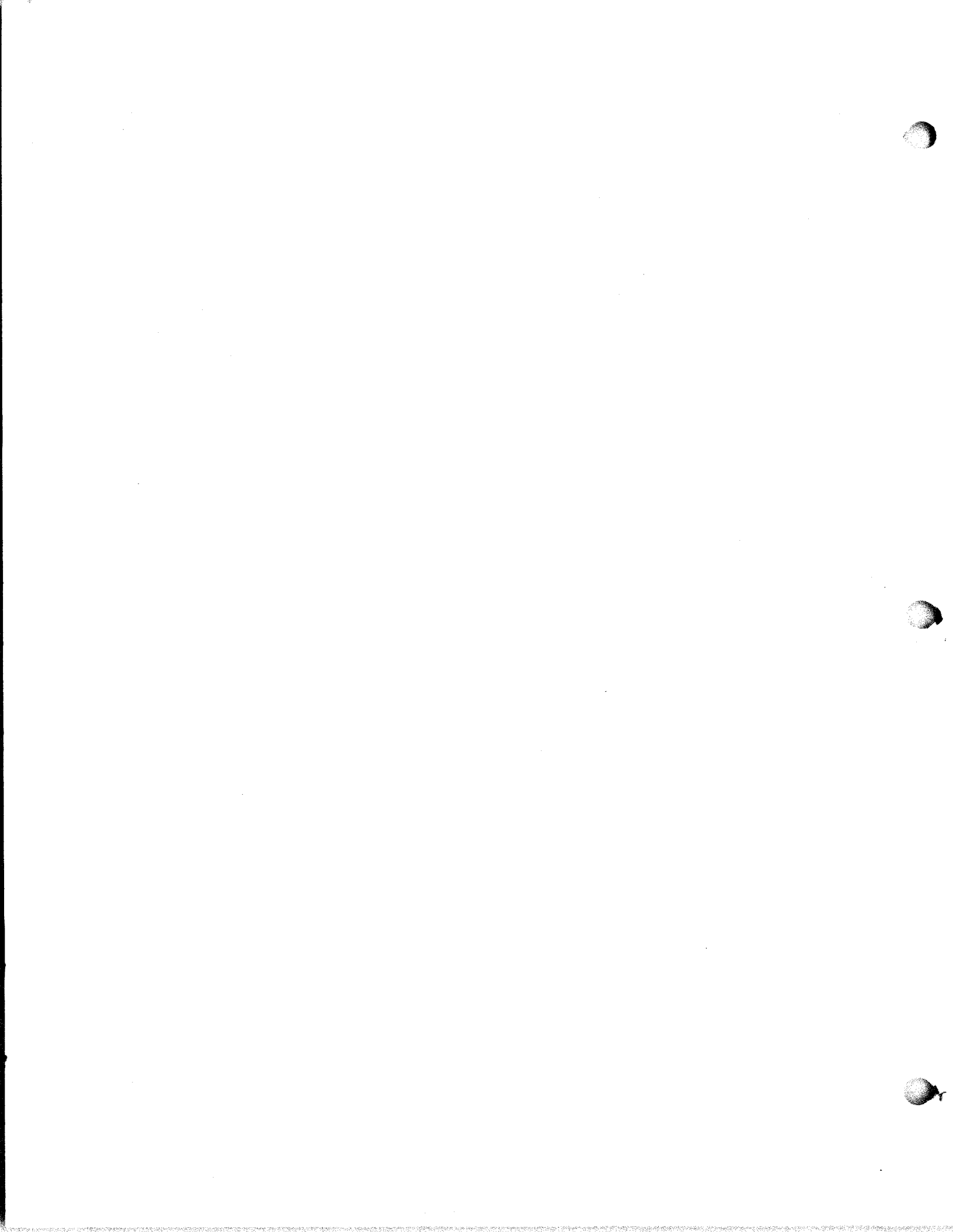

TEMPORARY CHANGE T-11 to TECHNICAL MANUAL w/change 1 for  
Radio Transmitting Sets AN/SRT-14, -14A thru-16, 16A,  
NAVSHIPS 0967-073-4010 (Formerly NAVSHIPS 92121A).

This Temporary Change contains information originally published  
as separate articles (Technical Manual Corrections) in the Electronics  
Information Bulletin, (EIB), number 650.

The instructions, described herein, for making these changes shall  
be followed only if they have not been previously accomplished at the  
time the EIB, in which the information appeared, was received.

The purpose of this Temporary Change is to assure that publica-  
tions drawn from stock, subsequent to publication of this information  
in the EIB, can be corrected.

Insert this Temporary Change in the technical manual immediately  
behind the front cover and preceding the title page or preceding the  
latest change or correction in effect.

Make pen-and-ink corrections or changes to the technical manual  
and change 1 as follows:

**A. Holders of technical manuals with an uncorrected change  
inserted shall make the following corrections:**

1. Page 1-13, column 1, paragraph 3, change first sentence to read as follows: "The high voltage power supply consists of six S-5130 silicon diode rectifiers in a three-phase, full wave rectifier circuit with a choke input filter."
2. Page 2-64, figure 2-67. +2,400/+3,000 volt D-C Supply, Simplified Schematic: change S-5343 to read "S-5130"; change CR-1503 to read "CR-1502"; change CR-1502 to read "CR-1501"; change CR-1501 to read "CR-1503."
3. Page 2-65, column 1, paragraph 5, change sentences 1 through 4 to read as follows: "If we assume that point HV-1 is positive and HV-2 is negative, rectifiers CR-1506 and CR-1501 are conducting. Electron flow is from HV-2 through CR-1501 to ground, then through the load and back through CR-1506. When the polarity of this phase reverses (HV-1 negative, HV-2 positive), rectifiers CR-1502 and CR-1505 conduct. Electron flow is now from HV-1 through CR-1502 to ground, then through the load and back through CR-1505."
4. Page 5-10, figure 5-4. Power Supply PP-1096/SRT(HVPS), Top View, Tube and Fuse Location: change S-5343 to read "S-5130."
5. Page 5-11, column 2, Table 5-8, change section 4 of Table 5-8 to read as follows:

4	Power Supply PP-1096/SRT (HVPS) (see Figure 5-4)			
	CR-1501	S-5130	CR-1504	S-5130
	CR-1502	S-5130	CR-1505	S-5130
	CR-1503	S-5130	CR-1506	S-5130

6. Page 7-103/7-104, figure 7-86, HVPS, Voltage and Resistance Chart: change S-5343 to read "S-5130" under all six pin diagrams.
7. Page 7-265/7-266, figure 7-164, Power Supply PP-1096/SRT(HVPS), Schematic Diagram: change S-5343 to read "S-5130"; change CR-1503 to

read "C-1502"; change CR-1502 to read "CR-1501"; change CR-1501 to read "CR-1503".

8. Page 8-103, Table 8-3. Table of Replaceable Parts: change reference designations V-1501 through V-1506 and related data as follows:

Ref. Design.	Stock Numbers	Name and Description	Locating Function
CR-1501	1N5960-755-7100	SEMI-CONDUCTOR DEVICE: Diode, Type S-5130	High Voltage Rectifier
CR-1502		Same as CR-1501	High Voltage Rectifier
CR-1503		Same as CR-1501	High Voltage Rectifier
CR-1504		Same as CR-1501	High Voltage Rectifier
CR-1505		Same as CR-1501	High Voltage Rectifier
CR-1506		Same as CR-1501	High Voltage Rectifier

7. Page 2-64, Change 1, figure 2-67. +2,400/ +3,000 volt d-c Supply, Simplified Schematic; change S-5343 to read "S-5130"; change CR-1503 to read "CR-1502"; change CR-1502 to read "CR-1501"; change CR-1501 to read "CR-1503."

8. Page 5-10, Change 1, figure 5-4. Power Supply PP-1096/SRT(HVPS), Top View, Tube and Fuse Location, change S-5343 to read "S-5130."

9. Page 7-103/7-104, Change 1, figure 7-86. HVPS, Voltage and Resistance Chart, change S-5343 to read "S-5130," under each pin diagram.

10. Page 7-265/7-266, Change 1, figure 7-164. Power Supply PP-1096/SRT(HVPS), Schematic Diagram, change S-5343 to read "S-5130"; change CR-1503 to read "CR-1502"; change CR-1502 to read "CR-1501"; change CR-1501 to read "CR-1503."

**B.**

Make the following pen and ink corrections to Change 1 of NAVSHIPS 92121(A):

1. Page 1 (of 3 pages) change title to read "Change 1 to Technical Manual for Radio Transmitting Set, AN/SRT-15-15A-16 and -16A, NAVSHIPS 92121(A)."

2. Page 1 (of 3 pages), under ACTION column, change S-5343 in the third line to read "S-5130."

3. Page 2 (of 3 pages), under ACTION column, change:

a. Line 4, paragraph 3, to read "... 1506 and CR-1501 are conducting. Electron flow...."

b. Line 5, paragraph 3, to read "... is from HV-2 through CR-1501 to ground, then...."

c. Line 8, paragraph 3, to read "... negative, HV-2 positive), rectifiers CR-1502 and...."

d. Line 10, paragraph 3, to read "... HV-1 through CR-1502 to ground, then through...."

4. Page 2 (of 3 pages), Table 5-8 under ACTION column, change S-5343 to read "S-5130."

5. Page 3 (of 3 pages), Table of Replaceable Parts, at top of page, insert "FSN 1N5960-755-7100" in Stock Number column. Under name and description column, change S-5343 to read "S-5130."

6. Page 3 (of 3 pages), Item 4, change to read: "When recording Change 1 entry on Record of Corrections Made page, insert 'as corrected by' and enter appropriate EIB number."

TEMPORARY CHANGE T-10 to TECHNICAL MANUAL for Radio Transmitting Sets AN/SRT-14, -14A, -15, -15A, -16, -16A NAVSHIPS 0967-073-4010 (Formerly NAVSHIPS 92121A).

This temporary change revises the manual to reflect the equipment changes made by Field Change(s) 14 through 25- AN/SRT-14-16 Series which appeared in EIB's 588, 632, 642, and 658.

When this change is included in the manual, the manual shall cover the equipment as though Field Change(s) 14 through 25- AN/SRT-14-16 Series had been accomplished on the equipment. This change does not supersede any other changes or corrections.

Maintenance Support Activities shall make this change in the technical manual immediately but shall keep the superseded data intact for support of equipments that have not been modified.

HOLDERS of equipment accompanied by technical manuals shall not make this change in the manual until accomplishment of the field changes referenced above.

Insert this temporary change in the manual immediately after the front cover and preceding the title page or prior changes or temporary corrections in effect. Make pen-and-ink changes in the manual as follows:

1. The following technical manual changes reflect equipment changes made by Field Changes 14-AN/SRT-14, 16-AN/SRT-15, and 16-AN/SRT-16

- a. Figure 7-159. Radio Frequency Amplifier AM-1008/SRT(RFA) wiring diagram (sheet 2 of 2). With pen and ink change the diagram to show DPDT switch instead of SPDT switch S-1305 and show connections in accordance with figure 1 of this correction.

- b. Table 8-3. Table of replaceable parts, page 8-89. Opposite S-1305, delete "N17-S-72018-7719" and substitute "N5930-050-2638". Delete contents in "Name and Description" column and substitute the following: "Switch, toggle: DPDT; 3 amp, 250V."

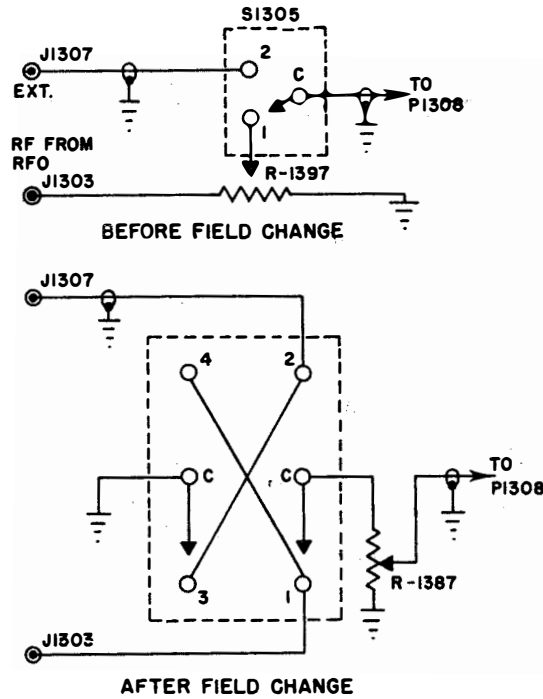

Figure 1

2. The following technical manual change reflects equipment changes made by Field Changes 15-AN/SRT-15A, -16A; 17-AN/SRT-15, -16.

a. Figure 7-151. Control-Indicator C-1352/SRT, Schematic Diagram. Draw a diagram in the blank space directly below M-401 showing the new relay K-402 with connections to S-402, C-402, and P-402-5. See Figure 2.

b. Figure 7-167. Electrical Equipment Cabinet CY-1571/SRT (100 W. Frame), Wiring Diagram. Show jumper from terminal 79 of E-606 to terminal 69 of E-605.

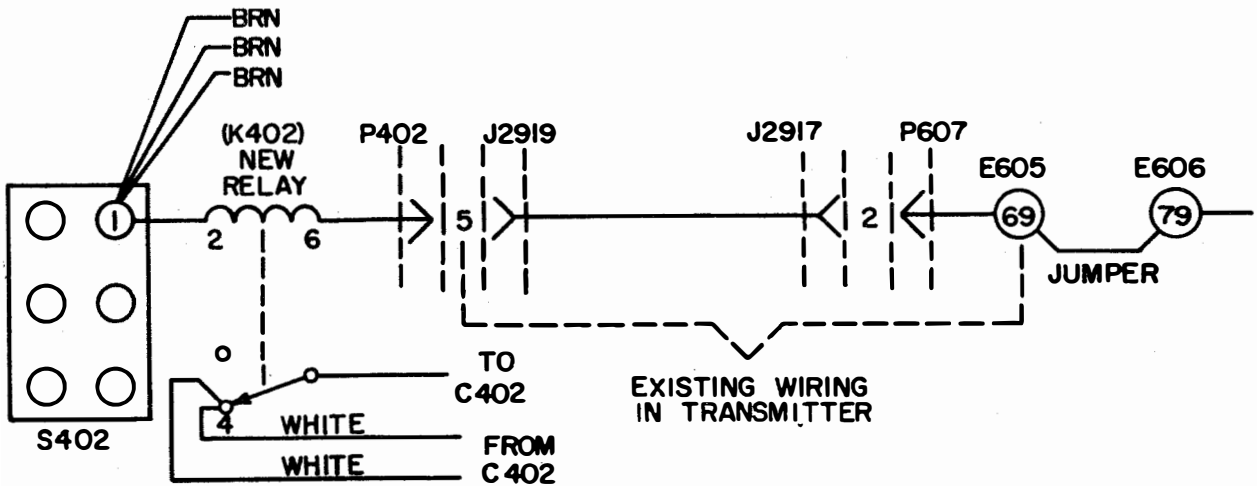

Figure 2. Pictorial Wiring Diagram

3. The following technical manual changes reflect equipment changes made by Field Changes 22-AN/SRT-14, -14A, -21; 25-AN/SRT-15, -16; 24-AN/SRT-15A, -16A.

a. Page 1-10, 1st column, 2nd paragraph, change 1st sentence to read: "It consists of three conventional full-wave silicon diode rectifiers. . ."

b. Page 1-10, 1st column, line 30, change "metallic" to read "diode"; line 31, delete the word "plate"; line 32, delete the word "filament".

c. Page 2-54, 1st column, paragraph d., line 4, change "metallic" to read "diode", change "CR-3001" to "CR-3004".

d. Page 2-55, make the following changes to figure 2-57: Change "CR-3001" to read "CR-3004"; above CR-3004, enter "Diode Assembly"; near each illustrated diode, enter "1N249RA".

e. Page 2-56, make the following changes to figure 2-58:  
(1) Change "V-3002" to read "CR-3002" and "5R4WGB" to read "1N1239."

(2) Change pin 6 to read pin 8; change pin 8 to read pin 6.

(3) "X" out lead from pin 8 of tube diagram through filament winding of transformer T-3001 to junction with lead from pin 2.

(4) Change tube diagram to diode diagram (see figure 3).

(5) Change pin 2 to read "pin 8".

f. Page 2-56, 1st column paragraph e., line 2, change "V-3002" to read "CR-3002"; line 9 delete entire sentence "This allows time for the rectifier filaments to read operating temperature before V-3002 begins to conduct."

g. Page 2-56, 2nd column, paragraph f., line 1, change "V-3001" to read "CR-3001"; line 8, delete "of V-3001". Paragraph g., line 2, change "V-3003" to read "CR-3003."

h. Page 2-57, make the following changes to figure 2-59:

(1) Change "V-3001" to read "CR-3001", and "5R4WGB" to read "1N1239."

(2) "X" out lead from pin 2 of the tube diagram through filament winding of transformer T-3001 to junction of lead from pin 8.

(3) Change Tube diagram to a "Diode diagram" (see figure 3).

1. Page 2-57, make the following changes to figure 2-60:

(1) Change "V-3003" to read "CR-3003", and "5R4WGB" to read "1N1239."

(2) "X" out lead from pin 2 of tube diagram through filament winding of transformer T-3001 to junction of lead from pin 8.

(3) Change "Tube diagram" to a "Diode diagram" (see figure 3).

j. Page 7-257/7-258, make the following changes to figure 7-160:

(1) Change "CR-3001" to read "CR-3004". Above CR-3004, enter "Diode Assembly"; near each illustrated diode enter "1N249RA".

(2) Change "V-3001" to read "CR-3001", "V-3002" to read "CR-3002" and "V-3003" to read "CR-3003", change "5R4WGB" to read "1N1239".

(3) "X" out all filament leads.

(4) Change the three Tube diagrams to "Diode diagrams" (see figure 3).

k. Page 7-259/7-260, make the following change to figure 7-161:

(1) Change "CR-3001" to read "CR-3004".

(2) "X" out leads removed by the field change.

(3) Redraw leads relocated by the field change.



l. Page 8-240, Table of Replaceable Parts, change "CR-3001" to read "CR-3004", change "N17-R-51071-1358" to read "1N5960-990-3081"; under Description column, delete description, enter "See bottom of page"; at the bottom of the page, enter the following description: "Diode Assembly, 2 Mounted Semi-Conductor Devices: Silicon Diode, Type 1N249RA".

m. Page Page 8-247, Table of Replaceable Parts, change "V-3001", "V-3002", and "V-3003", to read: "CR-3001", "CR-3002", and "CR-3003"; change "N16-T-55446-5" to read "9N5960-617-5670"; in Description column, change description to read "Semi-Conductor Device: Silicon Diode Type 1N1239".

n. Page 8-249, Table of Replaceable Parts, change Reference Designations "V-3001", "V-3002", and "V-3003" in the Locating Function column to read "CR-3001", "CR-3002", and "CR-3003".

NOTE:  
DOTTED LINES SHOW DELETED  
PORTION OF CIRCUIT.

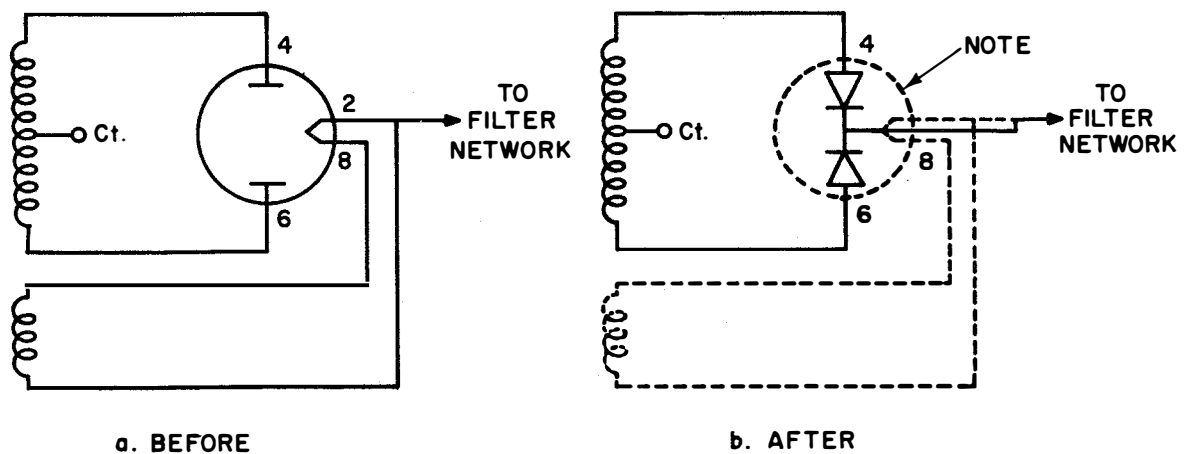

Figure 3

4. The following technical manual changes reflect equipment changes made by Field Changes 17-AN/SRT-14; 16-AN/SRT-14A; 20-AN/SRT-15, -16; and 18-AN/SRT-15A, -16A.

a. For equipment on board ship:

(1) Fig. 3-30, Page 3-61/3-62; Fig. 3-31, Page 3-63/3-64; and Fig. 3-32, Page 3-65/3-66; under notes add: "For interconnection between Transmitter Group OA-684/SRT, Antenna Coupler CU-372/SRT, and Radio Frequency Tuner TN-229/SRT refer to BUSHIPS Plan S6700-1410866 Rev. E."

(2) Fig. 7-170, Page 7-277/7-278, delete "J-3502, J-3501, J-3503, and J-3504". Above "P-3501," insert "Refer to BUSHIPS Plan S6700-1410866 Rev. E."

(3) Fig. 7-171, Page 7-281, Delete.

(4) Fig. 7-172, Page 7-282, Change "J-302" to read "J-301": change Pin "J" to read "A"; change Pin "M" to read "B"; change Pin "H" to read "C".

b. For Reserve Activities ashore (when alternate method is accomplished):

(1) Figure 3-30, page 3-61/3-62; figure 3-31, page 3-63/3-64; figure 3-32, page 3-65/3-66, under notes add "For interconnections between Transmitter Group OA-684/SRT, Antenna Coupler CU-372/SRT and Radio Frequency Tuner TN-229/SRT refer to BUSHIPS Plan 404-1860215."

(2) Figure 7-170, page 7-277/7-278, delete J3501, J3502, J3503 and J3504. Above P3501 insert "Refer to BUSHIPS Plan 404-1860215".

(3) Figure 7-171, page 7-281, delete.

(4) Figure 7-172, Page 7-282, change J302 to read J301; change Pin J to read A; change Pin M to read B; change Pin H to read C.

5. The following technical manual changes reflect equipment changes made by Field Changes 20-AN/SRT-14; 19-AN/SRT-14A; 23-AN/SRT-15, -16; and 21-AN/SRT-15A, -16A.

a. Page 8-42, K1101; page 8-70, K1306; under stock number column, change "SNSN N17-R-99999-0849", to "FSN9N5945--624-0769"; under description column, change existing description to: "Relay, Armature: three sets of form "C" contacts; 150V peak, 5 amps, one winding, 24V d-c, 0.12 amps, 9 terminals for contacts, 2 for coil, 0.016 sec. opr. time, 0.016 sec release time; 2-3/32 in. lg. by 1-17/32 in. h by 1-1/8 in wd O/A dimensions; two 6-32 holes on 0.75 mtg/c; mtg/c; CBTL Part A-1047994; includes mounting adaptor kit CBTL Part A-1047993 and relay CBTL Part A-1047963."

TEMPORARY CORRECTION T-8 TO TECHNICAL MANUAL FOR RADIO TRANSMITTING  
SETS AN/SRT-14, -14A, -15, -15A, -16, -16A NAVSHIPS 92121(A)

This temporary correction revises the manual to reflect equipment changes made by later versions of Field Change 12 - AN/SRT-14, -14A, 13 - AN/SRT-15, -15A, or 13 - AN/SRT-16, -16A. Excepting the following changes, all procurements of the aforelisted Field Changes are identical.

Make the following pen and ink additions, but do not delete existing text. At the bottom of every page that is changed, add an asterisk (\*) and the following note: "Pen and ink corrections apply only to later procurements of the field change." Insert this correction in the manual immediately after the front cover.

<u>PAGE NO.</u>	<u>CHANGE IN EFFECT</u>	<u>PARA &amp; LINE or FIG &amp; LOCATION</u>	<u>ACTION</u>
1-13	Orig.	Third paragraph, first sentence	Add semiconductor type S5130 or KX1820 and asterisk next to type S5343.
2-64	Ch. 1	Fig. 2-67	Same as above
5-10	Ch. 1	Fig. 5-4	Same as above
7-103	Ch. 1	Fig. 7-86	Same as above
7-104	Ch. 1	Fig. 7-86	Same as above
7-265	Ch. 1	Fig. 7-164	Same as above
8-103	Orig.	Name and Description column	Same as above
8-282	Orig.	Name and Address columns	General Instrument 65 Gouverneur Street Newark 4, New Jersey

This temporary correction is in effect on all technical manuals, NAVSHIPS 92121(A), associated with later procurements of Field Change 12 - AN/SRT-14, -14A, 13 - AN/SRT-15, -15A, or 13 - AN/SRT-16, -16A.



TEMPORARY CORRECTION T-7 to TECHNICAL MANUAL FOR RADIO TRANSMITTING SETS AN/SRT-14,  
-14A, -15, -15A, -16, and 16A  
NAVSHIPS 92121(A)

The purpose of this temporary correction is to provide procedures for determining, and correcting, if necessary, the presence of frequency discrepancies or spurious frequencies in the output of the RF oscillator. These supplementary procedures are to be accomplished after performing the checks and adjustments outlined in paragraphs 4g(1) through 4g(4)(b)3 of Section 6 of the technical manual, NAVSHIPS 92121(A), and the stepping oscillators in units 6 and 8 are locked on frequency for every digit.

It should be noted that in units 5, 6, 8, or 9, the tuned circuits following any of the numerous mixers have enough range, in some cases, to tune the highest mixing frequency as well as the sum and difference of the two mixing frequencies. However, some difficulty caused by off-frequency conditions and spurious frequencies has been experienced in observing a distinct tuning indication between the sum and difference frequencies in the tank circuit.

Maintenance support activities and holders of equipment accompanied by technical manuals shall insert this temporary correction in the technical manual immediately after the front cover and preceding T-6. The following note will also be entered in the blank space directly below paragraph 4g(4)(b)3 in Section 6 of NAVSHIPS 92121(A).

## NOTE

See Temporary Correction T-7 at the front of book for supplementary information to the above procedures.

## GENERAL:

The procedures are arranged in the following order.

1. Determining an off-frequency and/or a spurious-frequency condition.
2. Determining which unit/units are off frequency.
3. Correcting unit/units that are off frequency.
4. Locating source of spurious frequency.
5. Eliminating source of spurious frequency.

The test equipment required is as follows:

1. OS-8/U oscilloscope or equivalent
2. AN/USM-34 VTVM or equivalent

3. Receiver or receivers covering 2 to 38 MC. A calibrated field strength indicator, AN/URM-50 or equivalent, may be substituted for the receivers.

PROCEDURES:

1. Determining an Off-frequency and/or a Spurious-frequency Condition.

a. RFO output frequency check

(1) Place frequency selector knobs as follows: AA to 0, BB to 10, HH to 0, JJ to 9, CC to 9, DD to 9, EE to 10.

(2) Extend RFO drawer until J-2928 (RFO output jack located on underside in center rear of drawer) is accessible. Connect a cable, RG-58/U, with BNC connectors on each end, from J-2928 to vertical input on OS-8/U, or equivalent, oscilloscope. Set vertical attenuator to X10 or X100 position.

(3) Connect a cable from the 100 KC crystal test output jack, J-2931, to the horizontal AC input on the scope. Set the horizontal attenuator to X1 position and adjust horizontal gain for full horizontal sweep deflection.

(4) Place the operate/standby switch in the standby position and key the transmitter. Adjust the vertical gain on the scope for most easily discernible 1:1 lissajous pattern.

(5) Switch the 100 KC step knob HH to position 1 and observe a 2:1 lissajous pattern. Position 2 will give a 3:1, and so on through position 9 for a 10:1.

NOTE

If the lissajous pattern drifts slightly, adjust the interpolation oscillator zero for most stable pattern, or as an alternate, place a BNC T-connector at J-2 on unit 5 and run a cable from this T-connector to J-2155. (J-2155 is the interpolation oscillator input 3a.) This will give a stationary pattern on the scope. Obtaining the lissajous patterns of steps (4) and (5) determine that the mixers in units 5, 6, and 8 are properly tuned. If the proper lissajous patterns are not obtained, refer to paragraphs 2 and 3. Unit 9 mixer is determined to be operating properly by this check only for position 0 of the 5 MC step switch. However, unless adjustments C, C-0, C-1, C-2, or C-3, or replacement of associated components have been made, the 5 MC step switch should function properly for positions 1, 2, and 3 of the AA knob also. If there is a necessity for further check of unit 9, at this time, refer to 2.d., steps 2, 3, and 4; otherwise, after this checkout, the RFO is considered to be on frequency.

## b. Spurious frequency check

Spurious frequencies in the lissajous patterns, previously outlined in paragraph 1.a. (4) and (5) will appear as fuzz in the background of the discernible lissajous pattern. Refer to paragraphs 4 and 5 for locating provisions for eliminating spurious frequencies. Examples of patterns that may be encountered are given below:

## (1) Spurious frequencies present

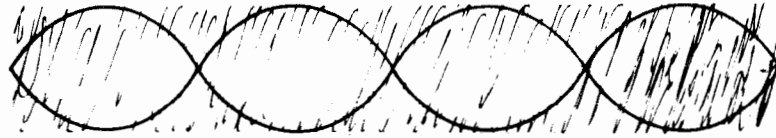

## (2) Hum content



## (3) Overdriven vertical amplifier in oscilloscope



## (4) Proper pattern

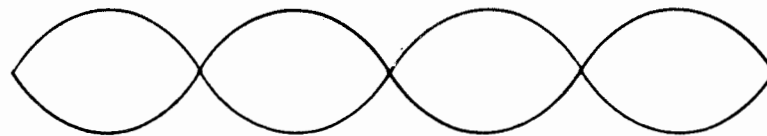

## NOTE

If all stepping oscillators are locked on, spurious frequencies usually found are caused by self-oscillation in units 5, 6, 8, 9, 11B or 11C. These self oscillations will beat with the desired frequency to produce a spectrum of frequencies in the output of the transmitter.

## 2. Determining which Unit/Units are Off Frequency:

## a. Unit 5

(1) Disconnect cable from 1b at J-2. Place BNC T-connector at J-2. Connect cable from 1b to one side of the T-connector, and to the other side connect a short length of RG-58/U with mating connectors to J-2155 (leaving 3a temporarily disconnected).

## NOTE

The 100 KC introduced into J-2155 substitutes an input to unit 5 from unit 3 to enable a fixed lissajous observation to be made.

(2) Switch 100 KC selector HH knob to position 7.

(3) Connect output of unit 5 (J-2156) to vertical input on OS-8/U and adjust vertical gain to maximum.

(4) From 100 KC step test jack (J-2932) connect a cable to horizontal AC input on scope; place the horizontal sweep/attenuator switch in position 1. Adjust horizontal gain for the most easily discernible 4:1 lissajous pattern. Obtaining a 4:1 pattern determines that mixers V-2151, V-2152, and V-2153 tuned circuits are tuned properly.

(5) Reconnect output of unit 5 to 5a.

## b. Unit 6

(1) Switch 10 KC step knob JJ to position 9 and connect output of unit 6 (J-2206) to vertical input on the scope. Adjust vertical gain of scope to maximum.

(2) Switch 100 KC step knob HH to position 5 (leaving 100 KC step test output connected to horizontal input on scope). Adjust horizontal gain for most easily discernible 5:1 pattern. Obtaining a 5:1 pattern checks the two mixers, V-2206 and V-2207, for proper tuning.

## c. Unit 8

(1) Unit 8 output ranges from 27.0 to 28.0 MC and cannot be observed on an OS-8/U. Using either a receiver or calibrated field strength indicator, the output frequency may be checked. Place HH knob to position 0.



(2) Loosely couple output of unit 8, J-2330, to receiver or field strength indicator and check for an output frequency of 27.0 MC. Care must be exercised when using a receiver to determine the output frequency. Observe the output meter on the receiver with the AVC off and determine the strongest frequency present. Keep the RF gain as low as possible so that, when the strongest signal is found, it will be the only signal heard.

(3) Switch HH knob to 9.

(4) Check for 28.0 MC output frequency.

#### NOTE

If the tuned circuits of mixer V-2330 are mistuned, the output frequency of unit 8 may be 23.0 MC to 23.0 MC in 100 KC steps, or 25.5 MC, regardless of 100 KC step position.

#### d. Unit 9

(1) Use appropriate method as for unit 8 to determine the output frequency of unit 9. Switch AA knob to position 0 and HH knob to 9. Check output frequency for 23.0 MC.

(2) Switch AA knob to 1 and check output frequency for 28.0 MC.

(3) Switch AA knob to 2 and check output frequency for 33.0 MC.

(4) Switch AA knob to 3 and check output frequency for 38.0 MC.

#### NOTE

Units 2, 4, 7, and 10 are harmonic generators and usually require very little adjustment. However, if the necessity arises, the 1 MC output from unit 2 will give a 10:1 lissajous pattern when taken with the 100 KC crystal test output. After obtaining the proper pattern, the 8 MC output from unit 4 will give an 8:1 lissajous pattern when taken with unit 2. The 5 MC output (7b) from unit 7 will give a 5:1 lissajous pattern when taken with unit 2. Outputs from 7a in unit 7 and 10a, 10b, and 10c from unit 10 may be checked with a receiver or field strength indicator. This does not have to be a precision frequency check since these harmonic generator outputs will be on frequency or off frequency in increments of 1 MC.

### 3. Correcting Unit/Units that are Off Frequency:

#### a. Unit 5

- (1) Extend unit on test cables.
- (2) Connect AN/USM-34 or equivalent to J-2161 and set for RF volts X1 scale with 5a disconnected at J-2156.
- (3) Connect AN/URM-25 to J-2151 and tune to 9.195 MC.
- (4) Remove V-2152.
- (5) Increase signal generator output until an indication on the VTVM is obtained and adjust Z-2155 and Z-2156 (top and bottom slugs) for maximum indication on the VTVM. Decrease generator output as necessary to keep indication on the X1 scale.

## NOTE

If no indication is obtained in step 3.a.(5), use appropriate tube socket adapter for XV-2154 and inject output of signal generator at pin 1 of V-2154 or pin 1 of Z-2155; adjust Z-2156 for maximum indication and then proceed as in 3.a.(5).

- (6) After Z-2155 and Z-2156 have been peaked, remove tube socket adapter from XV-2154; replace tube, replace V-2152, and remove V-2151.
- (7) Replace 4a at J-2151.
- (8) Connect generator at J-2155 and tune it to 1.2 MC.
- (9) Adjust generator output for indication on VTVM and adjust Z-2153, Z-2157, and Z-2154 (top and bottom slugs) for maximum indication.
- (10) If no indication is obtained, connect the generator to pin 1 of Z-2157 and adjust Z-2154 (top and bottom slugs).
- (11) Next move to pin 4 of Z-2153 and adjust Z-2157 (top and bottom slugs).
- (12) Connect generator at J-2155 and make final adjustments to Z-2153, Z-2157, and Z-2154 for maximum indication.
- (13) Reconnect 3a to J-2155.
- (14) Replace V-2151.
- (15) Connect generator to J-2 and tune to 1.1 MC.
- (16) Adjust generator output for indication on the VTVM. Adjust slugs of Z-2151 and Z-2152 (top and bottom slugs) for maximum indication on the VTVM.

(17) Reconnect 1b at J-2.

(18) Replace 5a to J-2156 and increase VTVM to X10 scale.

(19) Make very slight adjustments to all coils (top and bottom slugs) starting at Z-2156 and working toward Z-2151 for maximum indication on the VTVM. This should restore all mixer outputs to the proper frequency.

b. Unit 6

(1) Extend unit 6 on test cables.

(2) Disconnect 6b at J-2206 and connect VTVM at J-2211; set meter to RF volts X1 scale.

(3) Remove V-2206.

(4) Connect generator to J-2205 and tune to 10.45 MC.

(5) Increase generator output until indication is observed on the VTVM.

(6) Adjust T-2203, T-2204, and T-2205 for maximum indication on the VTVM. Reduce generator output as necessary during adjustments.

(7) If indications are not observed, inject signal at pin 1 of V-2209 and work back to J-2205, making successive adjustments to T-2205, T-2204, and T-2203 in that order. Make final adjustments of these transformers with the generator connected to J-2205.

(8) Replace V-2206.

(9) Reconnect 5a to J-2205.

(10) Remove V-2205.

(11) Switch 10 KC step switch to position 9, as indicated by red pointer on step switch.

(12) Connect generator at J-2204 and tune to 1.3 MC.

(13) Adjust generator output until an indication is observed on the VTVM.

(14) Set capacitors C-2267 and C-2277 to about midpoint in their tuning range. Now adjust slug on Z-2202 and Z-2203 for maximum indication on the VTVM.

(15) Replace V-2205.

(16) Reconnect 2c into J-2204 and 6b into J-2206.

- (17) Switch 10 KC step switch to position 5.
- (18) Make final adjustments of T-2205, T-2204, T-2203, Z-2203, and Z-2202. Adjust very slightly for maximum indication on the VTVM.
- (19) Replace unit and connect all cables.

## NOTE

If the voltage output of unit 6 drops off appreciably as the 10 KC step switch is stepped through all digits, refer to NAVSHIPS 92121(A) for adjustment of C and B sections of this switch.

## c. Unit 8

- (1) Extend unit 8 on test cables.
- (2) Remove V-2330.
- (3) Disconnect 8b from J-2330 and connect a VTVM at J-2336.
- (4) Connect generator at J-2329 and tune to approximately 28.0 MC. Adjust generator output for an indication on the VTVM.
- (5) Adjust bottom slugs of Z-2327, Z-2328, and Z-2329 for maximum indication on the VTVM.
- (6) Tune the signal generator to approximately 27.0 MC and adjust the top slugs of Z-2327, Z-2328, and Z-2329 for maximum indication on the VTVM.
- (7) Repeat steps 5 and 6 until no change is observed in the output.
- (8) Replace V-2330.
- (9) Reconnect 6b to J-2329.
- (10) Remove V-2329.
- (11) Connect generator to J-2328 and tune to approximately 17.5 MC.
- (12) Switch 100 KC step switch to position 9.
- (13) Set capacitors C-2405 and C-2406 to about midpoint in their tuning range.
- (14) Adjust the generator output to obtain an indication on the VTVM. Adjust L-2338 and L-2339 for maximum indication on the VTVM.
- (15) Reconnect 7a to J-2328.
- (16) Replace V-2329.

- (17) Connect a cable from J-2330 to J-2426 on unit 9.
- (18) Switch 10 KC knob JJ to position 9.
- (19) Readjust very slightly the bottom slugs of Z-2329, Z-2328, and Z-2327 for peak indication on the VTVM.
- (20) Switch the 100 KC step switch to position 0 and the 10 KC knob JJ to position 0.
- (21) Readjust very slightly the top slugs of Z-2329, Z-2328, and Z-2327 for maximum indication on the VTVM.
- (22) Replace unit and connect all cables.

## d. Unit 9

- (1) Extend unit 9 on test cables.
- (2) Remove V-2427 and insert VTVM RF probe into pin 1 of the tube socket.
- (3) Disconnect 8b from J-2426.
- (4) Connect the generator to J-2427 and tune to approximately 38.0 MC.
- (5) Switch the 100 KC step switch on this unit (S-2427) to position 9.
- (6) Switch the 5 MC step switch (S-2426) to position 3.
- (7) Set capacitor C-2431 (labeled C) to about its mid tuning range.
- (8) Adjust generator output until an indication is observed on the VTVM.
- (9) Adjust L-2429 (labeled C-3) for maximum indication on the meter. Decrease the generator output as necessary.
- (10) Tune generator to approximately 33.0 MC.
- (11) Switch the 5 MC step switch (S-2426) to position 2.
- (12) Adjust L-2428 (C-2) for maximum indication on the VTVM.
- (13) Tune signal generator to approximately 28.0 MC.
- (14) Switch the 5 MC step switch (S-2426) to position 1.
- (15) Adjust L-2427 (C-1) for maximum indication on the VTVM.
- (16) Tune the signal generator to approximately 23.0 MC.

- (17) Switch 5 MC step switch (S-2426) to position 0.
- (18) Adjust L-2426 (C-0) for maximum indication on the VTVM.
- (19) Replace V-2427.
- (20) Reconnect 8b to J-2426. Very slight readjustment of steps 3.d.(9) to (18) may now be necessary, and will be accomplished with the 5 MC step switch in positions 3-2-1-0, respectively.

## NOTE

If the voltage output of unit 9 falls off appreciably while being stepped in 5 MC, or 100 KC, steps, a complete unit alignment is necessary. Refer to NAVSHIPS 92121(A). Make adjustments as outlined except for steps 3.d.(9) to (18) of this procedure.

## 4. Locating source of spurious frequencies:

## a. Unit 5

- (1) Connect a VTVM to J-2161. Set for RF volts X10 scale.
- (2) Remove either 2b from J-2152 or 1b from J-2. The output voltage should drop to zero unless self oscillation is occurring in any stage of the unit.
- (3) If the output does not drop to zero, remove V-2151 and look for a drop in output voltage. Continue this procedure, moving toward output stage V-2154. Whenever the tube involved in self oscillation is removed, output will drop to zero.

## b. Unit 6

- (1) Connect a VTVM to J-2211. Set for RF volts X10 scale.
- (2) Remove V-2205. The output voltage should drop to zero unless self oscillation is occurring in any stage following V-2205.
- (3) If the output does not drop to zero, remove V-2206 and look for a drop in output voltage. Continue this procedure, moving toward output stage V-2209. Whenever the tube involved in self oscillation is removed, output will drop to zero.

## NOTE

Removing 2c from J-2204 or 5a from J-2205 should also cause the output to drop to zero.

## c. Unit 8

- (1) Connect a VTVM to J-2336. Set for RF volts X10 scale.
- (2) Remove V-2329. Output voltage of the unit should drop to zero unless self oscillation is occurring in any stage following V-2329.
- (3) If output does not drop to zero, remove V-2330 and look for a drop in output voltage. Continue this procedure moving toward the output stage V-2333. Whenever the tube involved in self oscillation is removed, output will drop to zero.

## d. Unit 9

- (1) Connect a VTVM to J-2432. Set for RF volts X10 scale.
- (2) Remove 8b from J-2426 or 7b from J-2427. Output voltage of the unit should drop to zero unless self oscillation is in any stage of the unit.
- (3) If the output does not drop to zero, remove V-2426 and look for a drop in output voltage. Continue this procedure, moving toward output stage V-2429. Whenever the tube involved in self oscillation is removed, output will drop to zero.

## e. Unit 11B

- (1) Connect a VTVM to J-2657. Set for RF volts X10 scale.
- (2) Remove 10b from J-2651 or 9b from J-2652. Key the transmitter; voltage output from the unit should be zero unless self oscillation is occurring in any stage of the unit.
- (3) If the output does not drop to zero, remove V-2651 and look for a drop in output voltage. Continue this procedure, moving toward output stage V-2654. Whenever the tube involved in self oscillation is removed, output will drop to zero.

## f. Unit 11C

- (1) Connect a VTVM to J-2807. Set for RF volts X10 scale.
- (2) Remove 10c from J-2801 or 9c from J-2802. Key the transmitter; the output voltage should be zero unless self oscillation is occurring in any stage of the unit.
- (3) If output does not drop to zero, remove V-2801 and look for a drop in output voltage. Continue this procedure, moving toward output stage V-2804. Whenever the tube involved in self oscillation is removed, output will drop to zero.

5. Eliminating spurious frequencies originating in the RFO drawer:

a. Hum content has been found present in the 100 KC outputs from unit 1. Distortion in these outputs may cause distortion in the outputs of other units and has been observed to cause distortion in the 10 KC countdown in unit 6. If the 100 KC crystal test output is observed on an OS-8/U oscilloscope, and with internal horizontal sweep adjusted to display several cycles on the CRT, the following may be observed:

- (1) Desired display
- (2) Unwanted distortion

Harmonic content in other units may be excessive because of improper tuning; however, this should be eliminated after accomplishing steps in paragraph 3 of this procedure.

(1) Connect oscilloscope vertical input to 100 KC crystal test output and adjust horizontal sweep for several cycles of display. Check for good grounding of the scope to the transmitter.

(2) Check S-2917 (zero adjust switch on lower front of RFO drawer) and make sure that this switch is in its center position. When this switch is in the Interpolation OSC position or FSO position, distortion occurs in the 100 KC output.

(3) Check the 250 VDC regulated for proper regulation and low ripple content in the DC output, i.e., if 250 VDC regulated adjustment does not bring the voltage up to 250 VDC, change rectifier tube and check as necessary. If excessive ripple exists, check filter capacitors and filter chokes.

(4) Substitute crystal oscillator tube V-2001 with a new 5654 type.

(5) Adjustment of L-2002 may be made, but this is recommended only if the slug has been moved from its original position, as can be determined by the glyptal seal being broken on the screw stud. Reset to original position or adjust for minimum discernible distortion in the presentation as illustrated in 5.a.(1).

b. Self oscillation (after having been isolated as in paragraph 4 of this procedure), may be caused by any of the following: faulty tube, dirty and/or improper mating of the bandswitches, open screen bypass capacitor, disturbance in placement of critical components, and/or component failure in plate de-coupling networks.

Unit 5 is not bandswitched; however, XV-2153 and XV-2154 have cathode and screen bypass capacitors that are an integral part of the tube socket assembly, and replacement of these sockets may be necessary to eliminate self oscillations in these stages.

(1) Replace the tube involved in self oscillation with a new tube and make sure the tube shield is in place.



(2) Clean all bandswitches with suitable contact cleaner (such as Cramolin) and check for proper contact mating, i.e., no broken stator contacts and that the wiper is mated with the proper stator contact when the switch is in its detent position.

(3) Check screen bypass capacitor by direct substitution or use ZM-11/U bridge.

(4) Check for proper shielding, covers secured, no missing stage dividers, and such.

(5) Check stage B-plus isolation resistor and bypass capacitors in B-plus line.



TEMPORARY CORRECTION T-5 to TECHNICAL MANUAL FOR RADIO TRANSMITTING SETS  
AN/SRT-14, -14A, -15, -15A, -16, -16A NAVSHIPS 92121(A)

This temporary correction revises the manual to reflect the equipment changes made by Field Changes 14-AN/SRT-14A, 15-AN/SRT-14, 16-AN/SRT-15A, -16A, 18-AN/SRT-15, -16. The purpose of this field change is to incorporate a time-delay circuit which will "hold-in" the antenna switching relay K-1306 during normal keying rates, and reduce the work load of the relay. The field change applies to all AN/SRT-14, -14A, -15, -15A, -16, -16A equipments.

When this change is included in the manual, the manual shall cover the equipment as though Field Changes 14-AN/SRT-14A, 15-AN/SRT-14, 16-AN/SRT-15A, -16A; 18-AN/SRT-15, -16 had been accomplished on the equipment. This correction does not supersede any other corrections or changes.

Maintenance Support Activities shall make this correction in the technical manual immediately but shall keep superseded data intact for support of equipments that have not been modified.

Holders of equipment accompanied by technical manual shall not make this correction in the technical manual until accomplishment of the field change.

Make the following pen-and-ink corrections. Insert this temporary correction in the technical manual immediately after the front cover and preceding T-4.

<u>Item</u>	<u>Figure/Table</u>	<u>Action</u>
1	7-153	Show jumper wire from terminal No. 10 of J-1103 to terminal No. 13 of J-1102
2	7-153	Show lead from terminal No. 9 of J-1103 disconnected and reconnected to terminal No. 5 of J-1101
3	7-153	Show black lead from terminal No. 3L of K-1101 connected to terminal No. 2R of K-1101.
4	7-153	Show resistor connected on one end to terminal 1C of K-1104 and indicate that the other end of the resistor is connected to terminal No. 2L of K-1101.

<u>Item</u>	<u>Figure/Table</u>	<u>Action</u>
5	7-158	Delete jumper from terminals 6R and 2C of K1306. Show lead from junction NC of S-1383 connected to terminal K-1306. Show terminal 2C of K-1306 connected to ground.
6	7-159 (Sheet 2 of 2)	Correct the wiring diagram to reflect the change made in item 3.
7	Table 8-3, Page 8-53	In the appropriate columns below R-1145 enter the following data: "R-1145, RESISTOR, fixed composition, 200-ohm, 1/2-watt, RC20DG201J; FSN F5905-279-2674."

TEMPORARY CORRECTION T-4 to TECHNICAL  
MANUAL for RADIO TRANSMITTING SET AN/SRT-16

This temporary correction contains information originally published in EIB 490 and shall be accomplished only if these errors were not corrected at the time the EIB was published or were not corrected in a subsequent change or revision of the particular equipment publication.

The purpose of this temporary correction is to assure that publications drawn from stock subsequent to publication of this information in the EIB can be corrected.

Make the following pen and ink corrections and insert this temporary correction in the publication immediately behind the front cover.

Page 7-257/7-258, Figure 7-160: Correct designation of terminal "J-3001-4" to read "J-3001-12".



AN/SRT-14,-15,-16  
TECHNICAL MANUAL CORRECTION-3

Make the following pen and ink corrections to the manual after accomplishment of Field Change 14-AN/SRT-14, 16-AN/SRT-15, 16-AN/SRT-16.

1. Figure 7-159. Radio Frequency Amplifier AM-1008/SRT (RFA), wiring diagram (sheet 2 of 2). With pen and ink change the diagram to show DPDTswitch instead of SPDT switch S-1305 and show connections in accordance with figure 1.

2. Table 8-3. Table of replaceable parts, page 8-89. Opposite S-1305, delete "N17-S-72018-7719" and substitute "N5930-050-2638". Delete contents in "Name and Description" column and substitute the following: "Switch, toggle: DPDT; 3 am, 250V".

Record this action on Record of Correction Made page, and adjacent to each pen and ink correction, by inserting the appropriate EIB number.





Page No.	Reference	Action
	:	:
	:	: Add E306, Insulator, Standoff 3/4 inch
	:	dia., melamine bonded fiberglass rod.
	:	NEVADA AIR PRODUCTS CO. No. 2012041
	:	:
	:	: Add E307, Insulator, Standoff 3/4 inch
	:	dia., melamine bonded fiberglass rod.
	:	NEVADA AIR PRODUCTS CO. No. 2012042
	:	:
4,5, & 6 of 9	:	: L301 - Change FTL D-2010915 to NEVADA
	:	AIR PRODUCTS CO. No. 2012020 Rev. A.
	:	:
1A of 14	:	: B3501 - Same as B303
	:	:
	:	: B3502 - same as B303

The installation of Field Change Kit 1-TN-229/SRT does not affect the installation instructions, the operation procedure, or the maintenance practice of the equipment.

Temporary Correction T-2 to the instruction book for Radio Transmitting Set AN/SRT-14, 14A, 15, 15A, 16, 16A, NAVSHIPS 92121(A).

Temporary Correction T-2 does not apply to NAVSHIPS 92121(A) until Field Change 1-TN-229/SRT has been accomplished. Therefore, DO NOT correct the instruction book until the Field Change has been accomplished.

Field Change 1-TN-229/SRT applies to all sets. Its purpose is to:

- 1) Replace electromagnetic actuator B303, B3501, and B3502 with improved type to prevent failure due to breakage and burn-out.
- 2) Replace sliding short E305 fitted nylon shoes to prevent excessive wear on the tuning coil L302.
- 3) Replace mounting screws for the vacuum capacitor, C3501 with nylon screws to prevent arc-over.

Insert this Temporary Correction immediately after the front cover of NAVSHIPS 92121(A), Volume 2 of 3, Index Number NEO 20148.

Table of Electrical Parts should be corrected with pen and ink as follows:

1. Revise information relating to the old parts, B303, B3501, B3502, E305, E306, E307, L301, and C376 and insert the following data regarding the new parts in the appropriate columns.

Page No.	Reference	Action
1,2, & 3 of 9	: Maintenance	: B303 Change Viking Tool No. B2011052
	: Parts List	: to NEVADA AIR PRODUCTS CO. 2011052
	:	: Rev. F.
	:	:
	:	: Add E305 Contact, Electrical, c/o ring
	:	: outer silver plated brass; contact
	:	: form strip silver alloy material;
	:	: 6 shoes nylon material
	:	: NEVADA AIR PRODUCTS CO. No. 2012004

UNCLASSIFIED



Change 1 to Technical Manual for RADIO TRANSMITTING SET AN/SRT-15/16

NAVSHIPS 92121(A)

This document revises the manual to reflect equipment changes made by Field Change 14--AN/SRT-15/16 pertaining to the conversion of Power Supply PP-1096/SRT (HVPS) to silicon diode rectifiers. The conversion to silicon diodes was required to obtain more reliable operation.

Maintenance Support Activities shall insert this Change in the technical manual just behind the front cover, after Field Change 14 is accomplished.

No Temporary Corrections are superseded by this Change.

1. Remove superseded pages and insert revised pages as indicated:

Page	Remove	Insert
T.P./A'	Orig/Orig	Ch. 1/Ch. 1
2-63/64 ✓	Orig/Orig	Orig/Ch. 1
5-9/10 ✓	Orig/Orig	Orig/Ch. 1
7-103/104	Orig/Orig	Ch. 1/Ch. 1
7-105/106 ✓	Orig/Orig	Orig/Ch. 1
7-265 } Blank	Orig	Ch. 1
7-266 }		
7-267 } Blank	Orig	Ch. 1
7-268 }		

2. Make all the following pen-and-ink corrections and mark "CH. 1" adjacent to the pen-and-ink correction.

First Issued In	Page No.	Ch. In Effect	Col'm or Fig.	Line or Location	Action
✓ Ch. 1	1-13	Orig	1	3rd para	✓ Change third paragraph, first sentence to read as follows: "The high voltage power supply consists of six <del>5548</del> silicon diode rectifiers in a three-phase, full-wave rectifier circuit with a choke input filter."
✓ Ch. 1	1-13	Orig	1	4th para	✓ Change fourth paragraph, second sentence to read as follows: "Filament power is applied to the high level modulator whenever the BOOSTER EMERGENCY SWITCH is ON."
✓ Ch. 1	2-62	Orig	2	1st line ✓	Change "HVPS" to read: "HLRM".



First Issued	Page No.	Ch. In Effect	Col'm or Fig.	Line or Location	Action
✓ Ch. 1	2-65	Orig	1	1st para	✓ Change first paragraph, second sentence to read as follows: "M-1501 is connected across 220 volts in parallel with one primary winding of the filament transformer T-1501, and thus records total time power is applied to the HLRM filaments."
✓ Ch. 1	2-65	Orig	1	4th para	✓ Change fourth paragraph, sentences 3 and 4 to read as follows: "Six half-wave rectifiers, CR-1501 through CR-1506, are connected as a three-phase full-wave rectifier. There are always two diodes conducting."
✓ Ch. 1	2-65	Orig	1	5th para	✓ Change fifth paragraph, sentences 1 through 4 to read as follows: "If we assume that point HV-1 is positive and HV-2 is negative, rectifiers CR-1506 and CR-1504 are conducting. Electron flow is from HV-2 through CR-1504 to ground, then through the load and back through CR-1506. When the polarity of this phase reverses (HV-1 negative, HV-2 positive), rectifiers CR-1503 and CR-1505 conduct. Electron flow is now from HV-1 through CR-1503 to ground, then through the load and back through CR-1505."
✓ Ch. 1	2-65	Orig	2	3rd para	✓ Change third paragraph to read as follows: "Transformer T-1501 has four secondaries which are no longer in use due to changeover from electron tube rectification to silicon diodes. Transformer T-1501 will remain in the unit to supply 220 volts to M1501 and K1504."
✓ Ch. 1	2-99	Orig	1	c	✓ Change. <i>This allows the HVPS heaters to warm up to read:</i> "This allows the HLRM to warm up before power is applied to the HVPS plate transformer."
✓ Ch. 1	2-127/128	Orig			✓ Delete "HVPS FIL. SUPPLY" box at E-1504.
✓ Ch. 1	4-12	Orig	1	1st para	✓ Change first paragraph, second sentence to read as follows: "Turning this switch on energizes tube filaments in the HLRM unit."
✓ Ch. 1	5-i/5-ii	Orig	5-4	Line 2	Change in list of illustrations, the word "Tube" to read: "Semiconductor".
✓ Ch. 1	5-11	Orig	2	Table 5-8	Change section 4 of table 5-8 to read as follows:

4 POWER SUPPLY PP-1096/SRT (HVPS) (See figure 5-4)			
CR-1501	<del>S5343</del> <sup>S130</sup>	CR-1504	<del>S5343</del> <sup>S130</sup>
CR-1502	<del>S5343</del> <sup>S130</sup>	CR-1505	<del>S5343</del> <sup>S130</sup>
CR-1503	<del>S5343</del> <sup>S130</sup>	CR-1506	<del>S5343</del> <sup>S130</sup>

✓ Ch. 1	7-99	Orig	2	Table 7-39	Change first line of fourth paragraph under heading "Probable Fault" to read as follows: "+2400/+3000-volt rectifier circuit (CR-1501 through CR-1506)."
✓ Ch. 1	8-103	Orig			Change reference designations "V-1501" through "V-1506" and related data in the "List of Replaceable Parts" as follows:

4605

CHANGE 1  
INSTRUCTION SHEET

NAVSHIPS 92121(A)

Reference Design.	Stock Numbers	Name and Description	Locating Function
CR-1501	5960-	SEMICONDUCTOR DEVICE: Diode, Type S5343 5130	High Voltage Rectifier
CR-1502		Same as CR-1501	High Voltage Rectifier
CR-1503		Same as CR-1501	High Voltage Rectifier
CR-1504		Same as CR-1501	High Voltage Rectifier
CR-1505		Same as CR-1501	High Voltage Rectifier
CR-1506		Same as CR-1501	High Voltage Rectifier

- Ch. 1 8-104 Orig Change reference designations "V-1501" through "V-1506" in the "Locating Function column" to read: CR-1501 through CR-1506.
- Ch. 1 8-282 Orig 1, 2, 3 & 4 Add the following to Table 8-7:

Prefix	Name	Address
SATA	Sarkes Tarzian Inc.	415 N. College Ave. Bloomington, Ind.

3. After these changes have been made, destroy all superseded pages. Do not destroy these pages until the complete manual has been checked against the "LIST OF EFFECTIVE PAGES."
4. Make appropriate entry on "RECORD OF CORRECTIONS MADE" page.  
 WHEN RECORDING CHANGE 1 ENTRY ON RECORD OF CORRECTIONS MADE PAGE  
 INSERT "AS CORRECTED BY" AND ENTER APPROPRIATE EIB NUMBER.



ELECTRONICS FIELD CHANGE BULLETIN  
BUREAU OF SHIPS, NAVY DEPARTMENT  
WASHINGTON, D. C.

14-AN/SRT-15  
14-AN/SRT-16

REPLACES ELECTRON TUBE DIODES  
V1501 THROUGH V1506  
FSN F5820-799-7432

TYPE I CLASS (A)  
ESTIMATED MANHOURS (4)

OPERATIONAL CHANGE ( )  
NON-OPERATIONAL CHANGE (X)

Prepared by  
FUTURONICS CORP.  
25-29 Matinecock Avenue  
Port Washington, New York

Contract: N600(24)60229

NOTE

The field change kit procured under contract N600(24)60229 is similar to that previously procured under contract NObsr-81089. However, in the present procurement, a higher rated silicon diode is used. This diode is an exact replacement for the 3B28 power tube.

AUTHORIZATION NOTICE: Forces afloat or station personnel shall accomplish this field change at the earliest opportunity on ship- or shore-installed equipment affected without reference to the Bureau of Ships.

EQUIPMENT AFFECTED: Radio Transmitting Sets AN/SRT-15 and AN/SRT-16: All serial numbers.

PURPOSE: To modify Power Supply PP-1096/SRT by replacing electron tube diodes V1501 through V1506 with silicon diodes CR1501 through CR1506. This modification provides more reliable operation.

EFFECT ON NOMENCLATURE: None.

IDENTIFICATION OF ACCOMPLISHMENT: Accomplishment of the field change can be determined by checking that silicon diodes CR1501 through CR 1506 have been installed. (See Change 1 of NAVSHIPS 92121(A) for location.)

LIST OF MATERIAL REQUIRED:

Item	Ref. Desig.	Supplied with Field Change Kit		Federal Stock No.
		Qty	Description	
1	CR1501 through CR1506	6	Silicon diode S5130 or KX1820	
2		6	Insulator Disk	
3	Wires, numbered 181 through 185	1	High Voltage Cable (with six clamps)	
4		1	Solvent (Acetone)	
5			Lacing Cord	

Required by Installing Activity

Screwdriver, 6 inch common  
Pliers, longnose, 6 inch  
Spintight, 3/8 inch and 5/16 inch

Soldering Iron, 100 W  
Solder 50/50  
ME-25A/V Multimeter with 5,000 volt  
adapter

WARNING

Do not make any field change with the high voltage power supply on. Ground all circuits prior to touching them.

NOTE

Refer to NAVSHIPS 92121(A), technical manual for Radio Transmitting Sets AN/SRT-15 and AN/SRT-16 when making this change.

PROCEDURE FOR THE MODIFICATION OF POWER SUPPLY PP-1096/SRT:

1. Pull out the drawer that contains the high voltage power supply, PP-1096/SRT.
2. Remove the six type 3B28 tubes.
3. Disconnect and remove the High Voltage Cable, which consists of wires 101 through 113, inclusive.
4. Unbolt tube socket XV1501 and remove the tube socket and the accompanying insulating disk. Add item no. 2, the disk marked CR1501, below the old disk. Replace both disks and the tube socket to the original mounting position. Bolt in place. (See figure 1.)

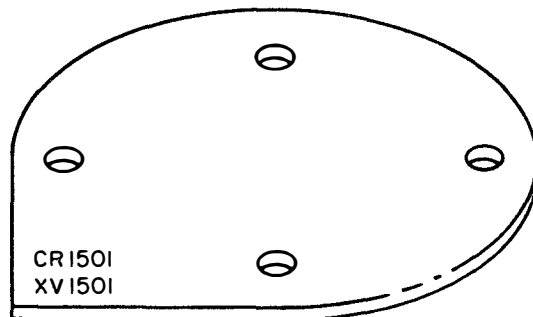

Figure 1. Insulating Disk

5. Repeat the procedure of step 4 for tube sockets XV1502 through XV1506. Make certain that the added insulating disk bears the corresponding reference designation, CR1502 through CR1506, respectively.
6. Emplace the new high voltage cable, item no. 3. Clamp the cable with the supplied clamps. Mount the old cable clamps in the same holes using the same hardware.
7. The high voltage cable connections are listed in the following table. Solder or bolt the connections as indicated.



Wire	From (Solder)	To (Bolt)
181 orange	HV <sub>1</sub> T1502	Pin F1, XV1502
182 orange	HV <sub>2</sub> T1502	Pin F1, XV1501
183 orange	HV <sub>3</sub> L1501	Pin F1, XV1506
184 orange	Pin 1, L1501	Pin F1, XV1504

8. Connect wire 185 (violet) from L1501, pin 2, to feedthrough insulator jack J1503. Solder both ends of the wire. To make the connection to J1503, it may be necessary to remove the feed-through capacitor.

NOTE

Dress lugs so that there is at least 1/2 inch air space between the lug and the nearest ground point. Wire numbers 157, 158, and 159 with tube caps O1506, O1505, and O1504 attached, must remain soldered to HV<sub>1</sub>, HV<sub>2</sub>, and HV<sub>3</sub> of T1502.

Jumper wire 153 (tan) from pin F1 of XV1506 to pin F1 of XV1505, and jumper wire 152 (tan) from pin F1 of XV1505 to pin F1 of XV1504 must remain in the circuit of the unit.

9. Insert one silicon diode, item number 1, in each of the six tube sockets.

10. Connect high voltage caps O1501 through O1506 to silicon diode CR1501 through CR1506, respectively.

11. Using the supplied solvent (item number 4), remove any of the old tube designations that are visible on the chassis. Spot tie the new high voltage cable, as indicated in figure 2, using the lacing cord supplied.

12. Close the equipment drawer and operate the equipment for 500 watt operation for 30 minutes, in accordance with the instructions contained in NAVSHIPS 92121(A), paragraph h of page 4-11. Check the following voltages with the transmitter operating at the 500 watt level. Using multimeter ME-25A/V with the 5,000 volt adapter.

Test Point	Test Voltage with Key (T) in Operating Position	
	CW	PHONE
CR1501 - Cap	0	0
CR1501 - Pin 1	1500	1200
CR1502 - Cap	0	0
CR1502 - Pin 1	1500	1200
CR1503 - Cap	0	0
CR1503 - Pin 1	1500	1200
CR1504 - Cap	1500	1500
CR1504 - Pin 1	3000	2400
CR1505 - Cap	1500	1500
CR1505 - Pin 1	3000	2400
CR1506 - Cap	1500	1500
CR1506 - Pin 1	3000	2400

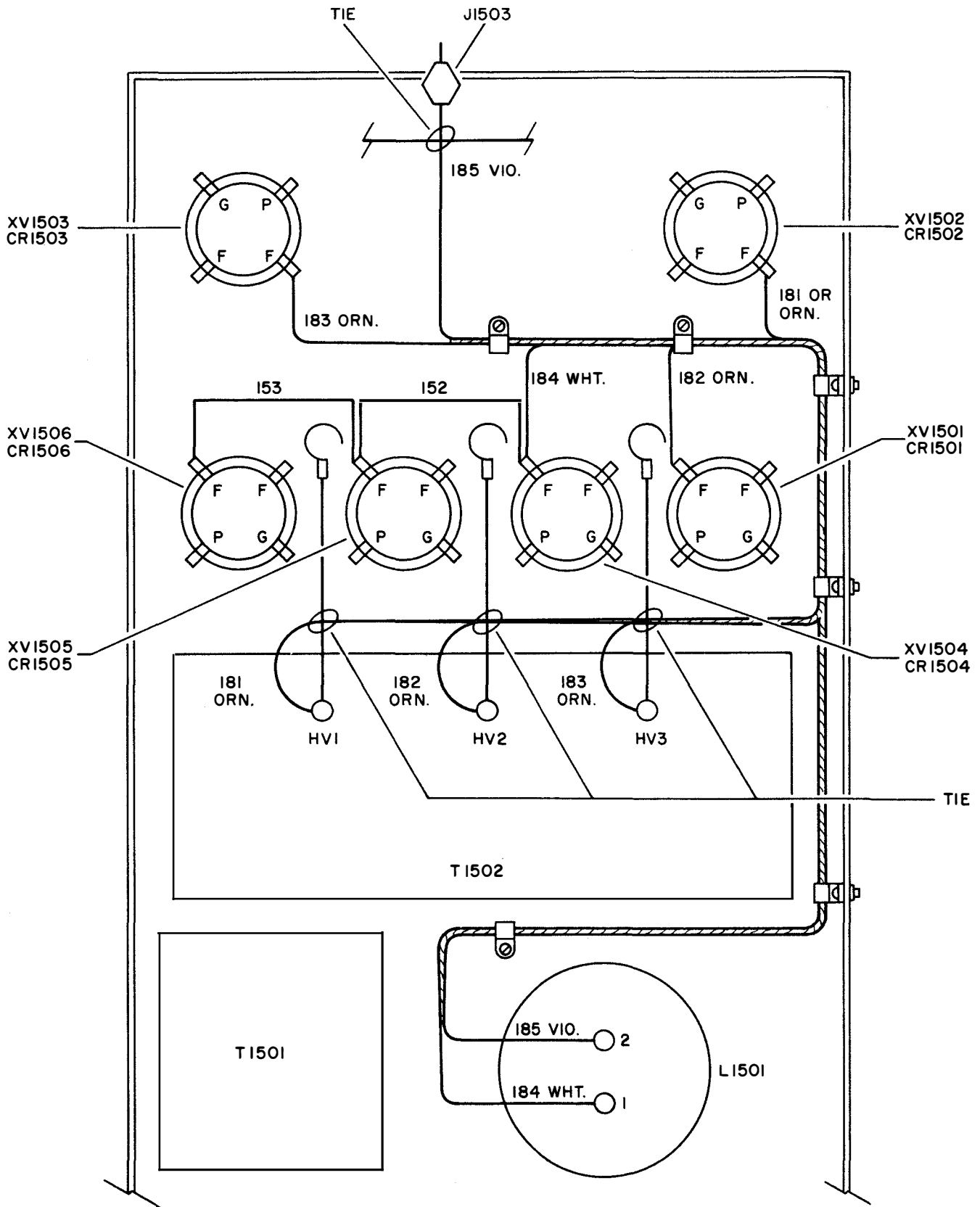

Figure 2. Field Change, Partial Wiring Diagram

ROUTINE INSTRUCTIONS:

1. Corrections to publications: Correct Technical Manual NAVSHIPS 92121(A), as indicated by Change No. 1 (with instruction sheets). Do not correct the manual until the field change has been accomplished.

2. Record of accomplishment: Personnel making this field change shall record the completion date of the change on the Electronic Equipment History Card - NAVSHIPS 536, and on the Record of Field Changes Card - NAVSHIPS 537.

3. Disposition of replaced material: The removed parts described below shall be turned in to the nearest supply activity for processing in accordance with current Bureau of Ships instructions.

Reference Designation	Quantity	Name of Part	Stock Number
V1501 through V1506	6	Electron tube type 3B28	N16-T-5322B
Wires, numbers 101 through 113	1	High voltage cable	

4. Disposition of field change bulletin: Maintenance support activities shall maintain a library copy of this field change bulletin. Holders of equipment shall not destroy this field change bulletin until the field change has been accomplished, the equipment tested, and the applicable manual corrected or replaced.

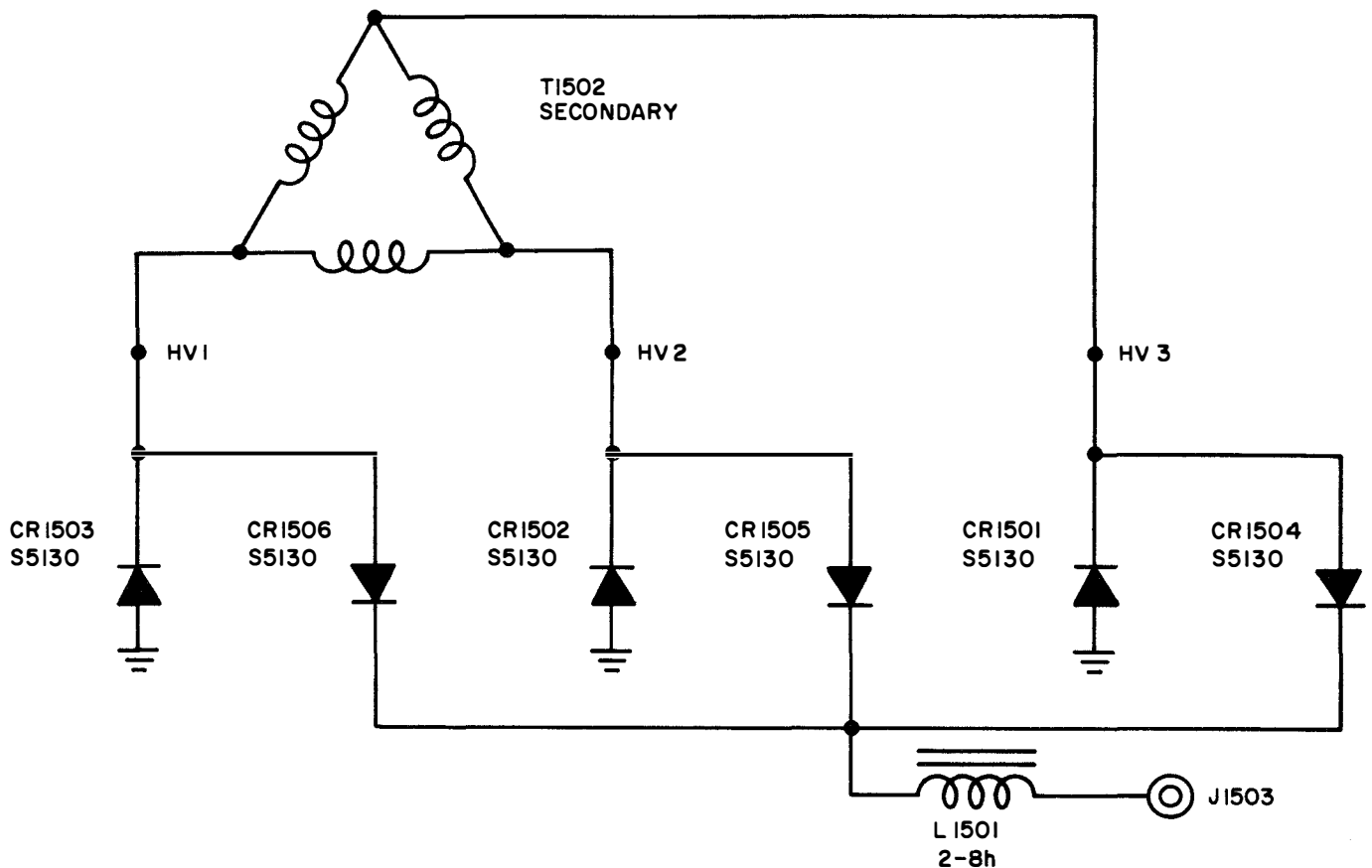

Figure 3. Field Change, Partial Schematic Diagram



TEMPORARY CORRECTION T-1 TO TECHNICAL MANUAL FOR RADIO TRANSMITTING SETS  
AN/SRT-14, -14A, -15, -15A, -16, -16A NAVSHIPS 92121(A)

This temporary correction revises the manual to reflect the equipment changes made by Field Change 12-AN/SRT-14, -14A, or 13-AN/SRT-15, -15A, or 13-AN/SRT-16, -16A. The purpose of this field change is to allow excitation of the Radio Frequency Amplifier RFA Drawer by Radio Set Group AN/WRA-1 through the external oscillator input, and elimination of spurious oscillation in R.F.A.

When this change is included in the manual, the manual shall cover the equipment as though Field Change 12-AN/SRT-14, -14A, or 13-AN/SRT-15, -15A or 13-AN/SRT-16, -16A had been accomplished on the equipment.

Holders of equipment accompanied by technical manuals shall not make corrections in the manual until accomplishment of the field change. Maintenance Support Activities shall make this correction in the technical manual immediately upon receipt.

Make the following pen-and-ink corrections. Insert this temporary correction in the technical manual after the front cover and preceding the title page. Personnel making corrections to the technical manual should make reference to figures 1 through 4 of this correction and proceed as follows:

1. Page 2-91, Figure 2-96, Buffer V-1301, Simplified Schematic
  - a. Add R-1398 from S-1305-2 to ground.
  - b. Add R-1704 in parallel with L-1332.
  - c. Add C-1382 from +300 volts side of L-1332 to ground.
2. Page 2-92, Figure 2-97, Buffer Tank Circuit, Simplified Schematic
  - a. Add R-1705 in parallel with L-1306.
  - b. Add C-1383 from +300 volts side of L-1332 to ground.
3. Page 2-92, Figure 2-98, IPA V-1302, Simplified Schematic
  - a. Add C-1382 from cap of V-1302 to junction of C-1306 and L-1302 (Not shown)
  - b. Add C-1383 between cam junction and ground.
  - c. Add R-1705 in parallel with L-1306.
  - c. Add C-1384 in parallel with C-1313 to ground.
4. Page 2-94, Figure 2-99, IPA Tank Circuit Simplified Schematic
  - a. Add R-1705 in parallel with L-1306.
  - b. Add C-1385 in parallel with C-1313 to ground.
5. Page 2-95, Figure 2-100, PA V-1304 Simplified Schematic

Add L-1346 and R-1703, R-1706, R-1707 in parallel between cap of V-1304 and C-1318.
6. Page 2-99, Figure 2-104, Antenna Switching Relay K-1306 Simplified Schematic

Add R-1398 between 1R and 3L on K-1306.

7. Page 7-251/7-252, Figure 7-158, Radio Frequency Amplifier AM-1008/SRT (RFA) Schematic Diagram  
Add R-1398 from S-1305-2 to ground.
8. Table 8-2, List of Major Units  
a. In Symbol Group column adjacent to 1301-1399, add "1700-1799, See T-1."
9. Table 8-3, Table of Replaceable Parts  
a. On page 8-85, delete R-1342 and pertinent data.  
b. Insert the following data on the pages indicated and in the appropriate columns.

Page	Reference Desig.	Stock Numbers	Name and Description
8-87	R-1398	N5905-252-5425	Resistor, fixed, 51 ohms, 4 watts.
8-87	R-1399	N5905-108-1764	Potentiometer, 10K, 2 watts slotted 1/4 in. shaft.
*	R-1701	N5905-102-0877	Resistor, fixed, 3K, 10 watts
*	R-1702	N5905-101-2473	Resistor, fixed, 5K, 10 watts
*	R-1703	N5905-171-1975	Resistor, 150 ohms, 2 watts
*	R-1704	N5905-279-3837	Resistor, 1 watt, 2700 ohms
*	R-1705		Same as R-1704
*	R-1706		Same as R-1703
*	R-1707		Same as R-1703
8-63	C-1382	N5910-564-5125	Capacitor, disc, 0.01 mfd 1000 v.d.c.
8-63	C-1383	N5910-556-9940	Capacitor, ceramic, variable (1.5-7 uuf)
8-63	C-1384	N5910-264-9494	Capacitor, padder, comp. (100-500 uuf)
8-63	C-1385		Same as C-1382
8-93	E-1329	N5940-242-7036	Insulator, feed through (Winchester FT-9)
8-75	L-1346	G6145-238-3409	Coil, parasitic, 4 turns #12 buss wire, 3/4 in. dia 1-1/2 in lg w/2 pig tails
8-90	S-1389	N5930-108-6729	Switch, toggle, DPDT

\* NOTE: Pen-and-ink additions to Table 8-3 cannot appropriately be made for these items. Refer to paragraph 8 of this correction.

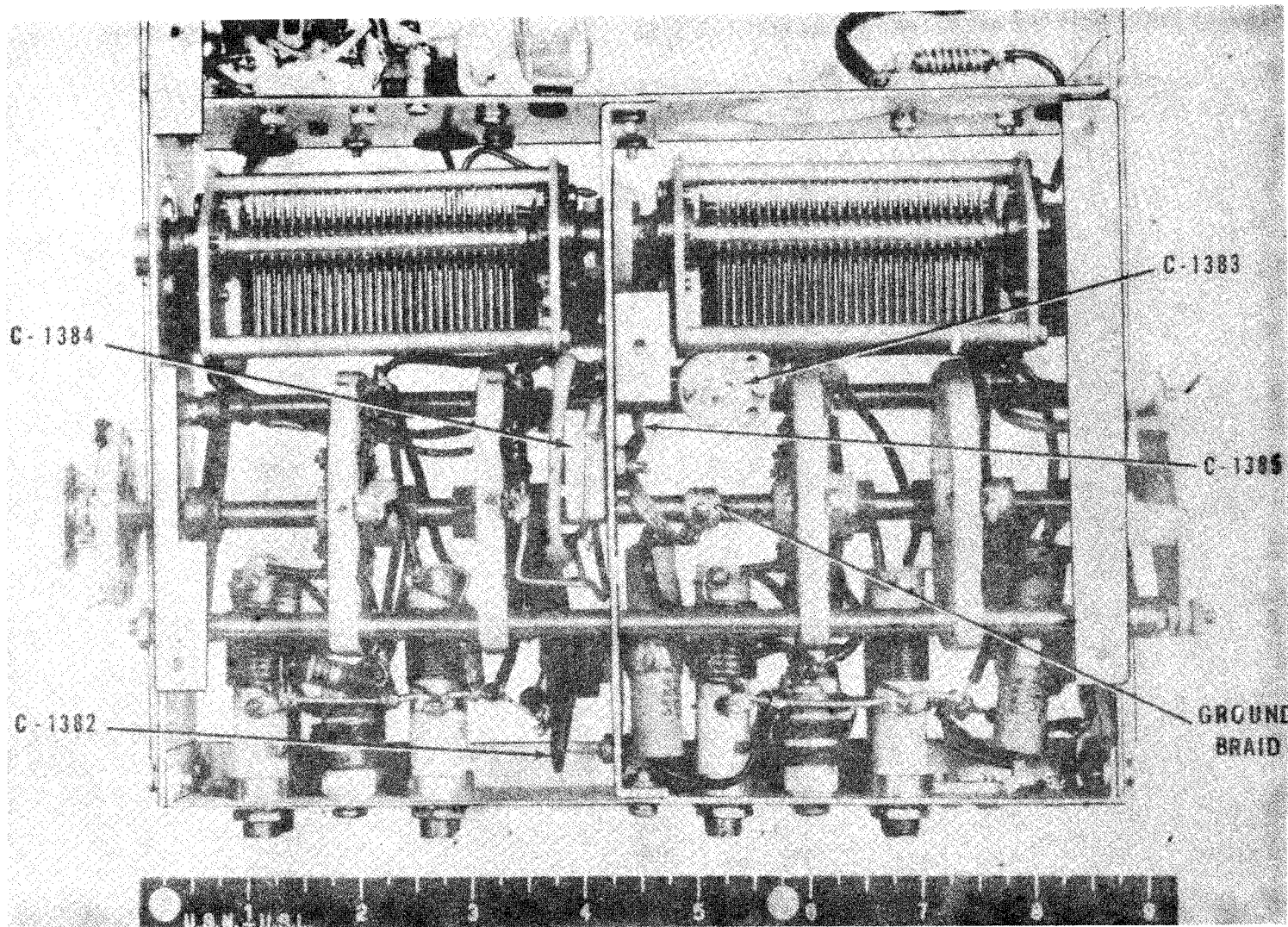

CORRECTION T-1

UNCLASSIFIED

Figure 1. Buffer and I. P. A. Subassembly, Right Side

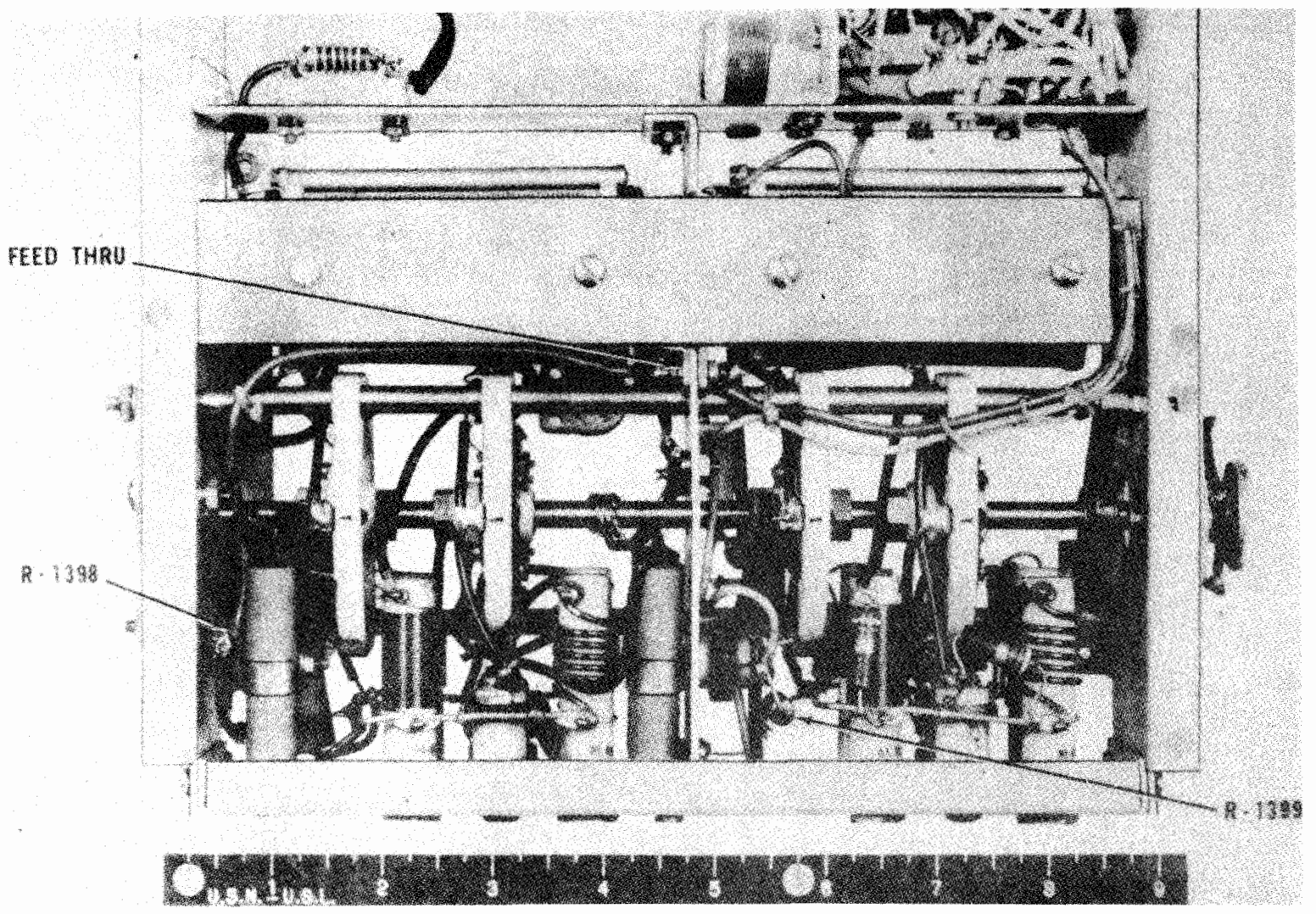

Figure 2. Buffer and I. P. A. Subassembly, Left Side

CORRECTION T-1

UNCLASSIFIED



IPA BIAS

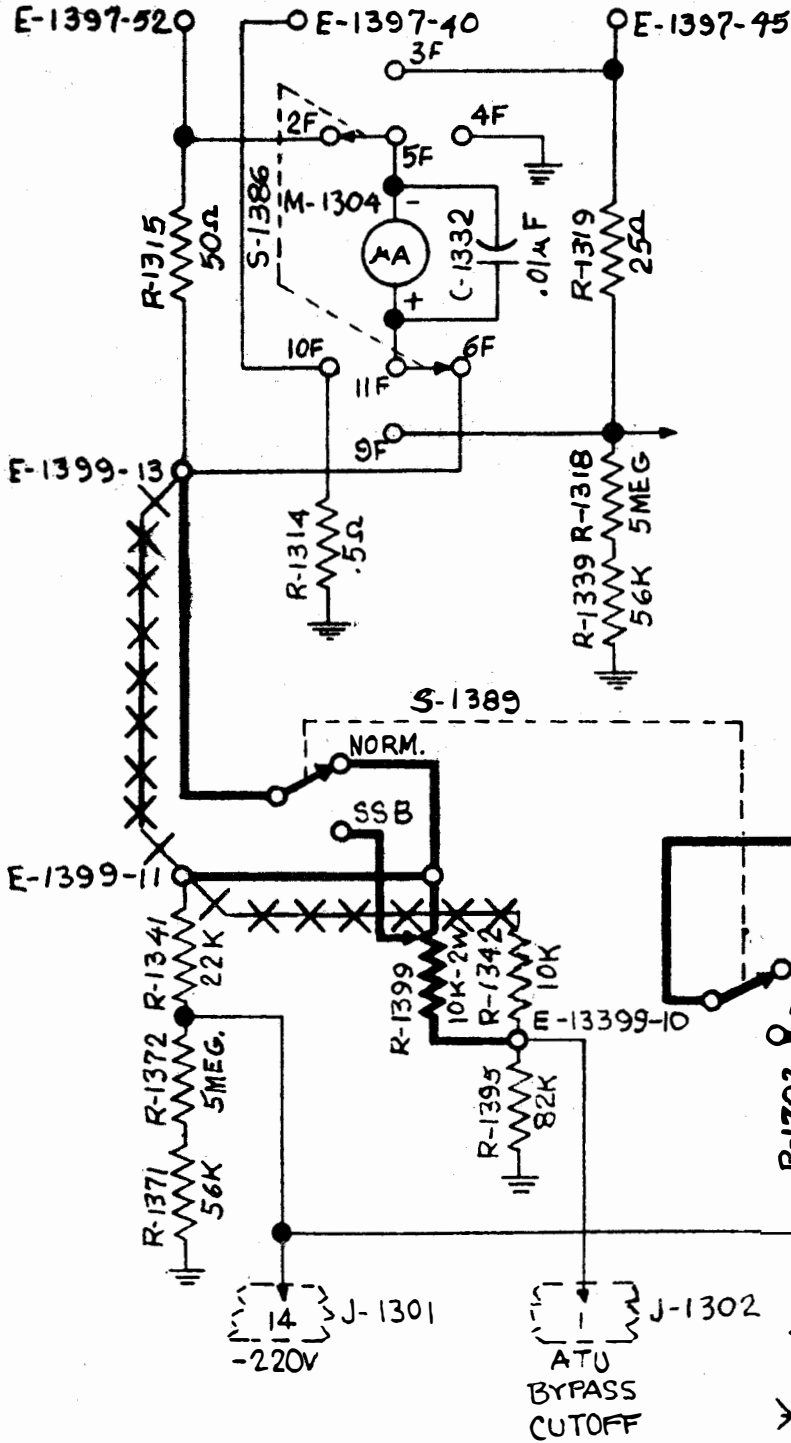

FIGURE 3

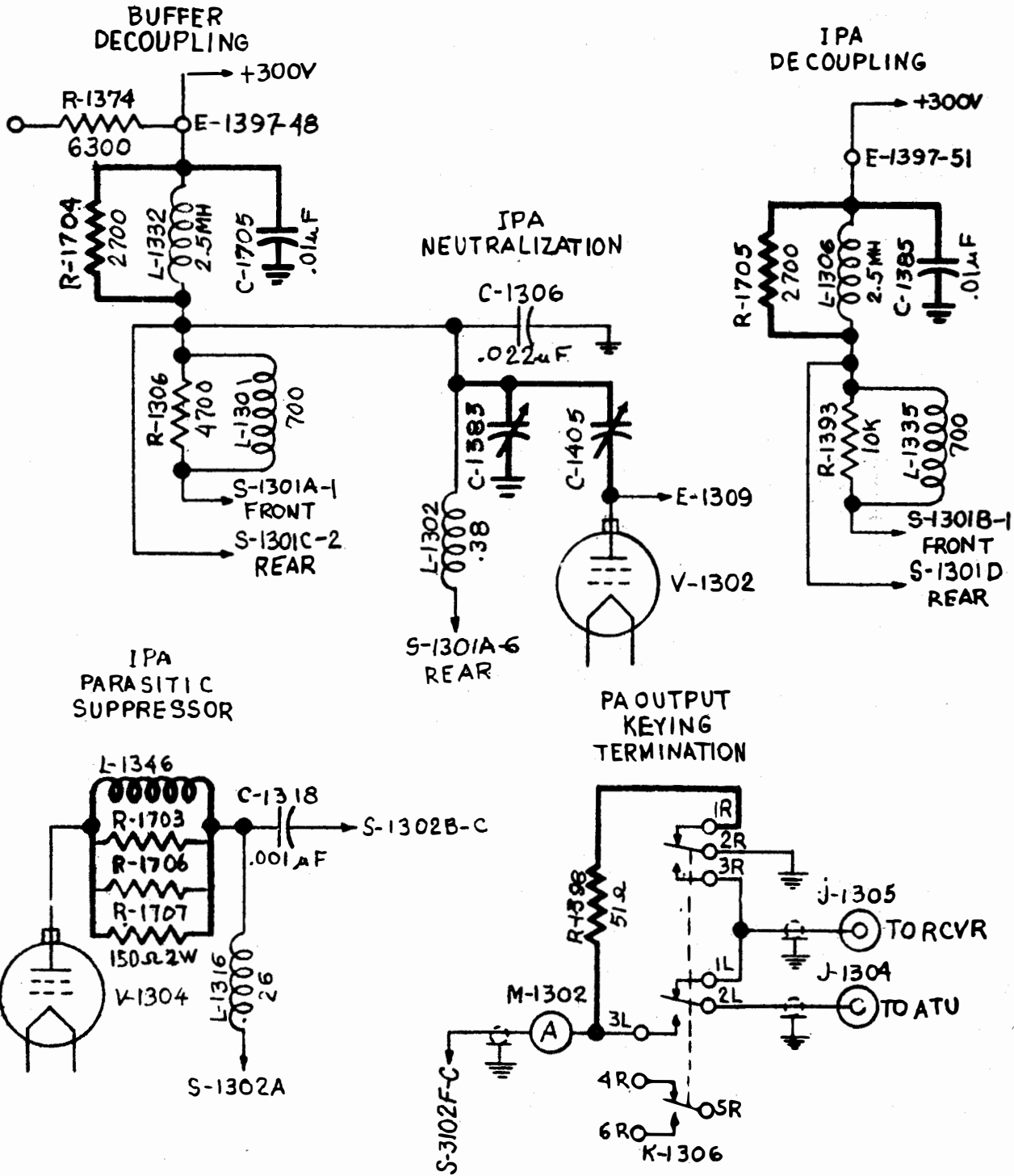

FIGURE 4