

INCH-POUND

MIL-STD-1680C(SH)
17 March 1993
SUPERSEDING
MIL-STD-1680B(SH)
1 August 1984

MILITARY STANDARD
INSTALLATION CRITERIA FOR SHIPBOARD
SECURE ELECTRICAL INFORMATION PROCESSING
SYSTEMS (U)



CLASSIFIED BY: NSA/CSSM-123-2
Review for Declassification on: 31 December 2013

DISTRIBUTION STATEMENT F: Further dissemination only as directed by Naval Sea Systems Command (Code 09T) or its authorized representative.

AMSC N/A

FSC 5810

UNCLASSIFIED

MIL-STD-1680(C)

DEPARTMENT OF THE NAVY

NAVAL SEA SYSTEMS COMMAND

WASHINGTON, DC 20362-5160

Installation Criteria for Shipboard Secure
Electrical Information Processing Systems

MIL-STD-1680C(SH)

(U) 1. This Military Standard is approved for use by the Naval Sea Systems Command, Department of the Navy, and is available for use by all Departments and Agencies of the Department of Defense.

(U) 2. Recommended corrections, additions, or deletions should be addressed to SEA 5523, Naval Sea Systems Command, 2531 Jefferson Davis Highway, Arlington, VA 22242-5160.

UNCLASSIFIED

MIL-STD-1680C(SH)

17 March 1993

FORWARD

(U) 1. OPNAV Instruction C5510.93 implements national policy on control of compromising emanations for facilities, system, or equipment used to process classified information. In addition, OPNAV Instruction 5510.1, Department of the Navy Information and Personnel Security Program Regulation, prescribes safeguarding policies and procedures to protect security information. Allied Communication Publication ACP-122, Communication Instructions, Security, provides guidance for communications security matters. The Navy Department Supplement to Department of Defense (DOD) Directive S5200.17 addresses specific physical security criteria applicable to shipboard special intelligence spaces. National Communication Security Instruction (NACSI) No. 4003, Standard Criteria for Safeguarding Communications Security Material, specifies minimum safeguards and standards for the protection of Communication Security (COMSEC) material.

(U) 2. This standard, in the same manner, translates the above instructions into criteria that address relevant equipment, hardware, and installation requirements. Accordingly, this standard does not address the associated administrative functions of classified information, or receipt and transmission of secure communications.

(U) 3. The use of low or high level signaling in the BLACK signal distribution system has no TEMPEST significance; either may be used.

(U) 4. This standard is based on supportive engineering and technical evaluation of past installation and operational experience and data. Adherence to the requirements specified herein should result in secure installations meeting the essential requirements of the above instructions.

(C) 5.

UNCLASSIFIED

MIL-STD-1680C(SH)
17 March 1993

(C)

(U) 6. The publication and distribution of this standard are not to be construed as implicit direction and authorization for implementation in ship alterations. Such direction and authorization will be implemented as programmed by the Chief of Naval Operations (CNO) through the Fleet Modernization Program (FMP).

(U) 7. This standard is to be applied to all ships as delineated herein (see 1.2). Ships under construction, undergoing ShipAlt modifications, or having equipment already installed under previous installation criteria for shipboard secure electrical information processing systems (SEIPS) (NAVSHIPS INST C5510.33 series or MIL-STD-1680 series) or specifications developed for those criteria, in general do not require retrofitting. New installations or proposals for installation subsequent to the date of this standard will invoke this standard.

(U) 8. Visual TEMPEST Configuration Control Inspections (VTCCIs) for all ships shall be conducted as specified herein (see 6.3). The inspection check-off sheets in Appendix F provide guidance on the applicability of each item to the ship inspection.

(U) 9. This standard shall be applied to systems and equipment in a secure processing center, special intelligence space, secure video control space, secure video viewing space, remote area, secure remote area, exposed remote station, and at a ship land-base test site having a secure electrical information processing system (SEIPS) as delineated in the standard, or as specified in the documents and drawings of the Commander, Space and Naval Warfare Systems Command (COMSPAWARSYSCOM) designated system commands.

(U) 10. This standard is an authoritative basis for the conduct of the following actions:

- a. Commanding Officers. In consideration of the responsibilities assigned directly to Commanding Officers by applicable security directives, this standard is a technically authoritative basis for assessing compliance with installation security requirements.

UNCLASSIFIED

MIL-STD-1680C(SH)
17 March 1993

(U) b. Field Technical Authorities. This standard is a basis for field inspections by Field Technical Authorities.

c. Design Engineers. This standard is a basis for preparation of applicable standard specifications, and installation drawings and requirements.

(U) 11. Each command or activity of the Naval establishment concerned with the installation of shipboard secure electrical information processing systems (SEIPS) and RED equipment is responsible for ensuring compliance with this standard.

(U) 12. This publication or the information it contains may not be released to foreign nationals without prior specific approval from the Chief of Naval Operations.

UNCLASSIFIED

MIL-STD-1680C(SH)

17 March 1993

TABLE OF CONTENTS

(U) Paragraph	Page
1. SCOPE	1
1.1 Scope	1
1.2 Application	1
2. APPLICABLE DOCUMENTS	2
2.1 Issues of documents	2
2.2 Other publications	6
2.3 Order of precedence	6
3. DEFINITIONS	7
4. GENERAL REQUIREMENTS	17
4.1 TEMPEST-related installation requirements	17
4.1.1 Signaling levels	17
4.2 Limitations	17
4.3 Supplementary standards	17
4.4 Cryptographic equipment in a portable configuration	17
4.5 Unique systems	17
5. DETAILED REQUIREMENTS	18
5.1 Primary TEMPEST-related installation standards	18
5.1.1 RED and BLACK signal and control line interfaces	18
5.1.2 Primary power	19
5.1.2.1 RED primary power	19
5.1.2.2 BLACK primary power	20
5.1.2.3 Individual power line filters	20
5.1.2.4 Primary power at 400 hertz (Hz)	20
5.1.2.5 Power filters	20
5.1.3 Battery	21
5.1.4 Rotary or tone/pulse dial analog telephone installations in a secure processing center	21
5.1.4.1 Location of rotary tone/pulse dial analog telephones with a shore-tie capability	22
5.1.5 Landline terminations for surface ships	22
5.1.6 Parallel data	23
5.1.6.1 NTDS communication section	23
5.1.6.2 NTDS parallel data section	23
5.1.7 Isolation of clocking and control circuits	23
5.1.8 Equipment	24
5.1.8.1 Common equipment cabinets	24
5.1.8.2 Relays and drivers	24
5.1.9 Cable-connecting enclosures	24

UNCLASSIFIED

MIL-STD-1680C(SH)

17 March 1993

TABLE OF CONTENTS

<u>(U) Paragraph</u>		<u>Page</u>
5.1.9.1	Shared junction boxes and cable entrance boxes	24
5.1.10	Cable	25
5.1.10.1	BLACK shielded cable	25
5.1.10.2	RED shielded cable	25
5.1.10.3	Large power cable exception	25
5.1.10.4	Secure voice cables	25
5.1.10.5	Armored cable	26
5.1.10.6	Cables not serving a secure processing center	26
5.1.10.7	Waveguide and rigid coaxial cables	26
5.1.10.8	Rotary or tone/pulse dial analog telephone line cables	27
5.1.10.9	Cable splices	27
5.1.10.10	Determination of RED high level and low level cables	27
5.1.10.11	RED cables external to the ship hull	28
5.1.10.12	RED and BLACK conductor separation	28
5.1.10.13	Separation of RED cables parallel to other cables	28
5.1.10.14	Separation of RED and BLACK cables at crossover points	28
5.1.10.15	Separation of RED cables at crossover to other cables	28
5.1.10.16	Cables shared between RED High Level and BLACK electrical distribution systems	29
5.1.10.17	Separation of RED and BLACK portable cables	29
5.1.10.18	Conduit to alleviate cable separation requirements	29
5.1.10.19	Conductive paths for signal and control lines	29
5.1.11	Secure Voice	29
5.1.11.1	Objective	29
5.1.11.2	Line and signal levels	30
5.1.11.3	Signal processing levels	30
5.1.11.4	Isolation between circuits	30
5.1.11.5	Plain/cipher secure voice signal line filters	30
5.1.11.6	Signal and control cables	30
5.1.11.7	Multichannel magnetic tape recorders in p/c secure voice	30
5.1.12	Non-metallic hull ship keying and signaling.	31
5.1.13	Bonding	31
5.1.14	Location of BLACK facsimile equipment	31

UNCLASSIFIED

MIL-STD-1680C(SH)
17 March 1993

TABLE OF CONTENTS

<u>(U) Paragraph</u>		<u>Page</u>
5.2	Support of primary TEMPEST-related installation standards	32
5.2.1	RED primary power distribution panel location	32
5.2.2	Equipment power connection	32
5.2.3	Primary a.c. power for ID-866/SG	32
5.2.4	Primary power to other facilities	32
5.2.5	RED battery location	33
5.2.6	Approved equipment	33
5.2.7	Cryptographic equipment modification	33
5.2.8	Cryptographic equipment cables	33
5.2.8.1	Electronic equipment cables	33
5.2.9	Radio transmitting equipment	33
5.2.10	Radio set controls	33
5.2.11	Approved cables	34
5.2.11.1	Cable connecting hardware	34
5.2.12	Power panels, junction boxes and terminal boxes	34
5.2.13	Cable hangers and supports	34
5.2.14	Bonding methods	34
5.2.14.1	Bonding classes	35
5.2.14.2	Class B bonds	35
5.2.14.3	Flexible bond strap fabrication	35
5.2.14.4	Solid bond strap fabrication	36
5.2.14.5	Preparation for use of bond straps	36
5.2.14.6	Assembled equipment units	36
5.2.14.7	Fabricated equipment units	37
5.2.14.8	Electronic equipment cabinets	37
5.2.14.9	Equipment mounted in electronic equipment cabinets	37
5.2.14.10	Bonding of non-resilient mounted equipment	38
5.2.14.11	Bonding of resilient mounted equipment or cabinets	38
5.2.14.12	Bonding of equipment mounted on slide foundations	38
5.2.14.13	Bonding of cryptographic equipment	38
5.2.14.14	Bonding of isolation devices and filters	41
5.2.14.15	Bonding of RED terminal boxes and power distribution panels or switch boxes	41
5.2.14.16	Bonding of BLACK terminal boxes and power distribution panels or switch boxes	41
5.2.14.17	Bonding of covers to RED terminal boxes and junction boxes	41
5.2.14.18	Bonding of covers to BLACK terminal boxes and junction boxes	41
5.2.14.19	Bonding of shields and armor on RED cables	41

UNCLASSIFIED

MIL-STD-1680C(SH)
17 March 1993

TABLE OF CONTENTS

<u>(U) Paragraph</u>	<u>Page</u>
5.2.14.20 Bonding of shields and armor on BLACK cables	42
5.2.14.21 Bonding of cables penetrating a secure processing center	43
5.2.14.22 Bonding of spare and unused cables and conductors	44
5.2.14.23 Bonding of conduit and metal ducts	44
5.2.14.24 Conduit	44
5.2.14.25 Bonding of non-processing equipment and devices	44
5.2.14.26 Removal of armor ,	45
5.2.15 Electrical perimeter barrier	45
5.2.15.1 Electrical perimeter barrier doors	45
5.3 Physical security installation standards	46
5.3.1 Security spaces	46
5.3.1.1 Physical perimeter barrier	46
5.3.1.1.1 Maintenance access panels	46
5.3.1.1.2 Normal access	46
5.3.1.1.3 Normal access door requirements, metallic hull surface ships	46
5.3.1.1.3.1 Secure remote area doors	47
5.3.1.1.4 Normal access door requirements, submarines	48
5.3.1.1.5 Normal access door requirements, non-metallic hull ships	49
5.3.1.1.6 Emergency exits	50
5.3.1.1.7 Acoustical isolation	50
5.3.1.1.8 Visual barrier	50
5.3.1.1.9 Intrusion alarm	50
5.3.1.1.10 Message passing scuttles	52
5.3.1.1.11 Message passing windows	52
5.3.1.1.12 Location of cryptographic and classified information processing equipment	52
5.3.1.1.12.1 Location of cryptographic equipment	52
5.3.1.1.12.2 Location of classified information processing equipment	54
5.3.1.1.13 Cryptographic repair facilities	54
5.3.1.1.14 Physical security of terminal boxes, cable boxes and similar enclosures	54
5.3.1.1.15 Paper destruction equipment	55
5.3.1.1.16 Cable marking	55
5.3.1.1.16.1 Cable designators	55
5.3.2 Modification of call signal station, type IC/D	55
5.3.3 Patch panel identification	56
5.3.3.1 Patch panel physical separation	56

UNCLASSIFIED

MIL-STD-1680C(SH)
17 March 1993

TABLE OF CONTENTS

<u>(U) Paragraph</u>		<u>Page</u>
5.3.4	RED and BLACK system sharing	56
5.3.4.1	RED operating positions	57
5.3.4.1.1	RED system interconnection	57
5.3.4.2	BLACK transmit operating positions	58
5.3.4.3	Shared teletypewriter circuits	58
5.3.4.3.1	Cautionary signs for shared operating position	58
5.3.4.4	Lock-out switch visual indicator	59
5.3.4.5	Remote voice disconnect	59
5.3.4.6	Speaker disconnect switch	59
5.3.5	Telephone push-to-operate feature	60
5.3.5.1	Telephone sets with intercommunication units	60
5.4	Temporary installations of RED processing equipment	60
6.	STATUS, INSPECTION AND REPORTS.	62
6.1	Ship status	62
6.1.1	National policy certification	62
6.1.2	Acceptable risk	62
6.1.3	Acceptable hazard	62
6.1.4	Change in ship status	62
6.2	Types of inspections	63
6.2.1	Visual TEMPEST configuration control inspection (VTCCI)	63
6.2.1.1	Visual TEMPEST inspection	63
6.2.1.2	Configuration control plan and elevation view diagrams	63
6.2.2	Partial TEMPEST inspection	63
6.2.3	Ship single secure electrical information processing system	64
6.3	Inspections required	64
6.3.2	Inspection of work by ship force	64
6.3.3	Delayed inspections	65
6.4	Briefing of ship representative	65
6.5	Reports of visual inspections	65
6.5.1	Required information	66
6.5.2	Distribution	67
6.5.3	Classification	67
6.6	Inspection records	68

UNCLASSIFIED

MIL-STD-1680C(SH)
17 March 1993

TABLE OF CONTENTS

(U) Paragraph	Page
APPENDIX A	
SPECIAL INTELLIGENCE SPACE INSTALLATIONS .	
	69
10. SCOPE	69
10.1 Scope	69
20. APPLICABLE DOCUMENTS	69
20.1 Issues of documents	69
30. DEFINITIONS	70
40. GENERAL REQUIREMENTS.	71
50. DETAILED REQUIREMENTS	71
50.1.1 TEMPEST status	71
50.1.2 Primary power to PICS	73
50.1.3 Equipment separation	73
50.1.4 Cables	73
50.1.5 Non-SI voice operation	73
50.2 Physical security	74
50.2.1 Physical perimeter barrier	74
50.2.1.1 Restriction on damage control fittings and cables	74
50.2.1.2 Removable hatches and deck plates	74
50.2.1.3 Vent and duct barriers	74
50.2.2 Normal access door	75
50.2.2.1 Contiguous SI spaces	75
50.2.3 Emergency exit	75
50.2.4 Acoustical isolation	76
50.2.5 Visual isolation	76
50.2.6 Security alarm system	76
50.2.7 Passing scuttles	76
50.2.8 Passing windows	76
50.2.9 Location of cryptographic equipment	76
50.2.11 Secure storage containers	77
50.2.12 Isolation of classified information processing systems	77
50.2.14 Sound powered telephones	78
50.2.14.1 Special intelligence sound powered telephone system	78
50.2.15 Special intelligence intercommunication announcing system	79
50.2.15.1 LS-653 or LS-654()/UYQ-21 in lieu of 12MC	79
50.2.15.2 Supporting intercommunication announcing systems	79

UNCLASSIFIED

MIL-STD-1680C(SH)
17 March 1993

TABLE OF CONTENTS

(U) Paragraph		Page
50.2.16	Commercial intercommunication equipment	80
50.2.17	General announcing systems	80
50.2.18	Pneumatic tube systems	80
50.2.19	Patch panels	81
50.2.20	Destruction equipment	81
50.2.21	Emergency power	81
50.3	Contingency SI space	81
50.3.1	Contingency space perimeter barrier	81
50.3.2	Contingency space accesses	81
50.3.3	Contingency space access marking	81
50.3.4	Contingency space secure storage containers	81
50.3.5	Contingency space electrical security	82
50.4	Short term SI space	82
50.5	Reports and inquiries	83

APPENDIX B

	CLOSED CIRCUIT TELEVISION SYSTEMS	84
10.	SCOPE	84
10.1	Scope	84
20.	APPLICABLE DOCUMENTS	84
20.1	Issues of documents	84
30.	DEFINITIONS	84
40.	GENERAL REQUIREMENTS	86
40.1	Purpose and coverage	86
40.2	RED CCTV system	86
40.3	Closed circuit television TEMPEST-related.	87
40.4	Closed circuit television physical security.	87
40.5	Commercial equipment.	87
40.6	Shipboard television systems	87
	Typical RED CCTV system	90
50.	DETAILED REQUIREMENTS	91
50.1	TEMPEST-related CCTV installation criteria.	91
50.1.1	RED CCTV system	91
50.1.1.1	RED CCTV video	91
50.1.1.2	RED CCTV audio	91
50.1.2	RED and BLACK CCTV electrical signal distribution system interfacing	91

UNCLASSIFIED

MIL-STD-1680C(SH)
17 March 1993

TABLE OF CONTENTS

<u>(U) Paragraph</u>		<u>Page</u>
50.1.3	RED CCTV equipment power connection	91
50.1.4	Rotary or tone/pulse dial analog telephone lines	91
50.1.5	Equipment separation	92
50.1.6	Television receivers	92
50.1.7	System video	93
50.1.7.1	Unused video terminations	93
50.1.7.2	Routing switcher and production switcher	93
50.1.7.3	Television receivers used with baseband video systems	93
50.1.7.4	RED baseband video outputs	93
50.1.8	Closed circuit television audio and control cables	93
50.1.9	Closed circuit television cable separation	93
50.1.10	Closed circuit television bonding	94
50.1.10.1	Bonding of CCTV equipment	94
50.1.10.2	Bonding of CCTV cable shields	94
50.2	Physical security	94
50.2.1	Equipment location	94
50.2.2	Closed circuit television audio amplifier or speaker control	94
50.2.3	Closed circuit television RED coaxial or triaxial continuous cable runs	95
50.2.	Rotary or tone/pulse dial analog telephones	95
50.2.5	Closed circuit television video or audio disconnect to viewing spaces	95
50.2.6	Special intelligence lockout	95
50.2.7	Closed circuit television interconnection safeguards	95
50.2.8	Video tape secure storage container	96
50.2.9	Closed circuit television cable designator	96

APPENDIX C

	FIBER OPTIC DISTRIBUTION SYSTEMS	97
10.	SCOPE	97
10.1	Scope	97
20.	APPLICABLE DOCUMENTS	97
30.	DEFINITIONS	97
40.	GENERAL REQUIREMENTS	97

UNCLASSIFIED

MIL-STD-1680C(SH)
17 March 1993

TABLE OF CONTENTS

(U) Paragraph		Page
50.	DETAILED REQUIREMENTS	97
50.1	TEMPEST-related installation criteria	97
50.1.1	Electrical or electronic portions of fiber optic system.	97
50.1.2	Fiber optic parts.	98
50.2	Physical protection	98
50.2.1	Fiber optic cable marking	98
50.2.2	Fiber optic cables processing TS or SI information	98
50.2.3	Switching matrix	99

APPENDIX D

	SPAWAR TEMPEST-APPROVED EQUIPMENT AND SYSTEMS	100
10.	SCOPE	100
10.1	Scope	100
20.	APPLICABLE DOCUMENTS	100
30.	DEFINITIONS	100
40.	GENERAL REQUIREMENTS	100
40.1	Equipment Groupings	100
40.2	Military type designators	101
50.	DETAILED REQUIREMENTS	102
50.1	SPAWAR TEMPEST-approved equipment and systems	102
50.2	RED/BLACK signal interfaces	110
50.3	Low level equipment not qualifying as SPAWAR TEMPEST-approved	113
50.4	Low level equipment requiring connection to RED primary power	115

APPENDIX E

	COMBAT SYSTEM SHIP LAND BASED TEST SITE	117
10.	SCOPE	117
10.1	Scope	117
10.2	Application	117
10.3	Precedence	117
20.	APPLICABLE DOCUMENTS	117
20.1	See basic document	117

UNCLASSIFIED

MIL-STD-1680C(SH)

17 March 1993

TABLE OF CONTENTS

<u>(U) Paragraph</u>	<u>Page</u>
30. DEFINITIONS	117
40. GENERAL REQUIREMENTS	118
40.1 Electrical and physical perimeter barriers	118
40.2 Ship land based test site building . . .	118
40.3 Grounds	118
50. DETAILED REQUIREMENTS	118
50.1 General	118
50.2 Approved cables	118
50.3 Normal access doors	119
60. STATUS, INSPECTION AND REPORTS	119
60.1 Ship land based test site status	119
60.1.1 National policy certification	119
60.1.2 Acceptable risk	119
60.1.3 Development SLBTS system configuration change	119
60.1.4 Production SLBTS system configuration change	119
60.1.5 Operational limitations	119
60.1.6 Visual TEMPEST configuration control inspection	120
60.1.6.1 Visual TEMPEST inspection	120
60.1.6.2 Configuration control plan and elevation view diagrams	120
60.1.7 Partial TEMPEST inspection	120
60.1.8 Single system	121
60.2 Inspections	121
60.2.1 Processing classified information	121
60.2.2 Inspection of work	121
60.2.3 Priority correction of discrepancies	121
60.2.4 Inspection checkoff sheets	121
60.2.5 Configuration control programs	122
60.2.6 Briefing of SLBTS representatives	122
60.3 Reports of visual TEMPEST configuration control inspections	122

APPENDIX F

INSPECTION CHECK-OFF SHEETS	125
10. SCOPE	125
10.1 Scope	125
20. APPLICABLE DOCUMENTS	125

UNCLASSIFIED

MIL-STD-1680C(SH)
17 March 1993

TABLE OF CONTENTS

(U) Paragraph	Page	
30. DEFINITIONS	125	
40. GENERAL REQUIREMENTS	125	
50. DETAILED REQUIREMENTS	125	
50.1 Correction of discrepancies	125	
50.2 Past installations	126	
50.3 Use of inspection check-off sheets	126	
50.4 Classification	127	
50.5 Detailed requirement and discrepancy data	128	
APPENDIX G		
SAMPLE INSPECTION REPORTS		279
10. SCOPE	279	
10.1 Scope	279	
20. APPLICABLE DOCUMENTS	279	
30. DEFINITIONS	279	
40. GENERAL REQUIREMENTS	279	
50. DETAILED REQUIREMENTS	279	
50.1 General	279	
50.2 VTCCI report	279	
50.3 Partial VTI report	280	
50.4 Configuration control drawings	280	
APPENDIX H		
BOATS AND CRAFT		306
10. SCOPE	306	
10.1 Scope	306	
20. APPLICABLE DOCUMENTS	306	
30. DEFINITIONS	306	
40. GENERAL REQUIREMENTS	306	
40.1 TEMPEST-related installation requirements	306	
40.1.1 Electrical signal distribution system	306	
40.1.2 Data and teletype	306	

UNCLASSIFIED

MIL-STD-1680C(SH)

17 March 1993

TABLE OF CONTENTS

<u>(U) Paragraph</u>		<u>Page</u>
40.1.3	SPAWAR TEMPEST-approved equipment and systems	306
40.1.4	TEMPEST-related and supportive details	306
40.2	Physical security installation requirements	307
40.3	Applicability	307
50.	DETAILED REQUIREMENTS	307
50.1	General	307
50.1.1	RED and BLACK electrical signal distribution system interfacing	307
50.1.2	Combined radio and secure systems	308
50.1.3	Primary power	308
50.1.3.1	RED Power	308
50.1.4	Cable	308
50.1.5	Secure voice signal lines	309
50.1.6	Bonding	309
50.2	Support of TEMPEST-related installation criteria	310
50.2.1	Cryptographic equipment modification	310
50.2.2	Cryptographic equipment cables	310
50.2.3	Bonding methods	310
50.2.3.1	Bonding via mounting hardware	310
50.2.3.2	Solid bond straps	311
50.2.3.3	Cryptographic equipment	311
50.2.3.4	Power filters.	311
50.2.3.5	Resilient mounted equipment	312
50.2.3.6	Bonding of shields and armor on RED cables	312
50.2.3.7	Unused and spare conductors	312
50.3	Physical security installation criteria	312
50.3.1	Security spaces	312
50.3.2	Location of cryptographic and RED processing equipment	312
50.3.3	RED and BLACK system sharing	313
50.3.4	Speaker disconnect switch	314
50.4	Temporary installations	314
	APPENDIX I	
	ILLUSTRATIONS	315
10.	SCOPE	315
10.1	Scope	315
20.	REFERENCED DOCUMENTS	315

UNCLASSIFIED

MIL-STD-1680C(SH)
17 March 1993

TABLE OF CONTENTS

<u>(U) Paragraph</u>	<u>Page</u>
30. DEFINITIONS	315
40. GENERAL REQUIREMENTS	315
50. DETAILED REQUIREMENTS	315
50.1 TEMPEST installation criteria illustrations.	315
FIGURE 1. Landline installation block diagram.	316
FIGURE 2. Landline installation wiring diagram	317
FIGURE 3. NTDS block diagram	318
FIGURE 4. Bonding of slide foundation.	319
FIGURE 5. Bonding of resilient mounted equipment	320
FIGURE 6. Bonding of equipment cabinet to foundation	321
FIGURE 7. Armor and Shield Bonding to Connector Box	322
FIGURE 8. Connector Plug Bonding	323
FIGURE 9. Box Clamp and Connector Bonding	324
FIGURE 10. Bonding of armor using connectors without stationar strain relief	325
FIGURE 11. Armor and Shield bonding to bulkhead penetration box	326
FIGURE 12. Penetration box mounting and bonding details	327
FIGURE 13. Penetration box single bar details	328
FIGURE 14. Penetration box stacked bar details	329
FIGURE 15. Bulkhead penetration adapter	330
FIGURE 16. Bonding of conduit via connectors	331
FIGURE 17. Bonding of conduit via straps and weld	332
FIGURE 18. Modification of call signal station, t pe IC/D	333
FIGURE 19. PICS RED/BLACK signal interface	334
FIGURE 20. T pical shipboard baseband video RED CCTV	335
FIGURE 21. RED and BLACK CCTV electrical signal distribution system interface	336
FIGURE 22. <u>Bonding of TSEC/KG-30 Family.</u>	337

APPENDIX J

MICRO/MINI COMPUTER SYSTEM	
10. SCOPE	338
10.1 Scope	338
20. APPLICABLE DOCUMENTS	338
30. DEFINITIONS	338

UNCLASSIFIED

MIL-STD-1680C(SH)
17 March 1993

TABLE OF CONTENTS

<u>(U) Paragraph</u>	<u>Page</u>
40. GENERAL REQUIREMENTS	338
50. DETAILED REQUIREMENTS	338
50.1 General	338
50.1.1 Primary power	338
50.1.2 Shielded cables	338
50.1.3 Grounding	339
50.1.4 Cable grounding	339
50.1.5 Interconnection	339
50.1.6 Electrical Perimeter Barrier	339
50.1.7 Separation	339
50.2 Physical security	340

UNCLASSIFIED

MIL-STD-1680C(SH)
17 March 1993

TABLE OF CONTENTS

(U) Paragraph

Page

UNCLASSIFIED

MIL-STD-1680C(SH)
17 March 1993

(U)

1. SCOPE

(U) 1.1 Scope. This standard sets forth the design and installation criteria applicable to shipboard secure electrical information processing systems (SEIPS) including detailed hardware and equipment requirements and the applicable inspection and reporting procedures and documentation.

(U) 1.2 Application. This standard is applicable to the extent specified herein to new construction and active fleet installations in surface ships and submarines. New installation requirements are covered by the following circumstances:

- a. When installing a new subsystem (for example, a tactical satellite subsystem), all components of the new subsystem shall be installed in accordance with these criteria.
- b. When replacing a processing equipment in a subsystem (for example, replacement of an obsolete teletypewriter (TTY) with a Navy Standard Teletypewriter (NST) in a subsystem) the replacement unit and connecting cables shall be installed in accordance with these criteria.

UNCLASSIFIED

MIL-STD-1680C(SH)
17 March 1993

(U) 2. APPLICABLE DOCUMENTS

(U) 2.1 Issues of documents. The following documents of the issue in effect on date of invitation for bids or request for proposal, form a part of this standard to the extent specified herein.

SPECIFICATIONS

FEDERAL

- FF-H-121 - Hardware, Builder's Door-Closers.
- FF-P-110 - Padlock, Changeable Combination (Resistant to Opening By Manipulation and Surreptitious Attack).
- FF-S-1169 - Shredding Machine, Office Type, Classified Wastepaper,
- MIL-C-17 - Cable, Radio Frequency, Flexible and Semirigid, General Specifications for.
- * MIL-C-17/28 - Cable, Radio Frequency Flexible Coaxial 50 OHMS M47/028RG58.
- * MIL-C-17/29 - Cable Radio Frequency Flexible Coaxial, 75 OHMS M17/29 RG59.
- * MIL-C-17/45 - Cable, Radio Frequency, Flexible Twin 78 OHMS M17/45 RG108.
- * MIL-C-17/74 - Cable, Radio Frequency Flexible Coaxial 50 OHMS Unarmored M17/07RG213 & Armored M17/074 RG215.
- * MIL-C-17/75 - Cable, Radio Frequency Coaxial 50 OHMS M17/75 RG214 & M17/75 RG365.
- MIL-C-915 - Cable and Cord, Electrical, For Shipboard Use, General Specification for.
- * MIL-C-3655 - Connector, Plug and Receptacle, Electrical (Coaxial, Series Twin), and Associated Fittings, General specification for.
- * MIL-C-3655/4 - Connector Adapter, Class I (Coaxial Series Twin), Type UG-493A/U.
- * MIL-C-5541 - Chemical Coatings on Aluminum and Aluminum Alloys.
- MIL-L-15596 - Lock, Combination (Safe and Safe Locker).
- MIL-T-22361 - Thread Compound, Antiseize, Zinc Dust-Petrolatum.
- * MIL-C-24640 - Cable, Electrical, Lightweight for Shipboard Use, General Specification for

UNCLASSIFIED

MIL-STD-1680C(SH)
17 March 1993

- (U) MIL-C-24643 - Cable and Cord, Electrical, Low Smoke, for Shipboard Use, General Specification for
- * MIL-C-28872 - Cabinet, Electronic Equipment CY-4516C/S().
- * MIL-C-39012 - Connectors, Coaxial, Radio Frequency.
- MIL-C-39012/1- Connectors, Plug, Electrical, Coaxial, Radio Frequency, (Series N (Cabled) Pin Contact, Class 2).
- * MIL-C-39012/16- Connector, Plug, Electrical, Coaxial, Radio Frequency, (Series BNC, (Cabled), Pin Contact, Class 2).
- MIL-C-52913 - Control, Electronic Access.
- MIL-A-55339 - Adapter, Connector, Coaxial, Radio Frequency, (Between Series and Within Series), General Specification for.
- MIL-A-55339/4 - Adapter, Connector, Coaxial, Radio Frequency, (Within Series N (Hermetic and Non-Hermetic)), Class 2, Straight Receptacle.
- MIL-A-55339/13 - Adapter, Connector, Coaxial, Radio Frequency, (Within Series BNC (Hermetic and Non-Hermetic)), Class 2, Straight Receptacle.

STANDARDS

MILITARY

- MIL-STD-188-114- Electrical Characteristics of Digital Interface Circuits.
- MIL-STD-220 - Method of Insertion-loss Measurement.
- MIL-STD-1310 - Shipboard Bonding, Grounding, and Other Techniques for Electromagnetic Compatibility and Safety.
- MIL-STD-1397 - Input/Output Interfaces, Standard Digital Data, Navy Systems.
- * MIL-STD-1553 - Aircraft internal time division command/response multiplex data bus.

DRAWINGS

NAVAL SEA SYSTEMS COMMAND

NAVSHIPS

- MSC 122-1842876- Non-Magnetic Vault Type Door.
- S3209-860213- Locker, Safe, Type Number 8.
- S6501-73801 - Call, Signal Station, Type IC-D, SYM 2988.

UNCLASSIFIED

MIL-STD-1680C(SH)
17 March 1993

- (U) S6501-74062 - Lightning Arrester for Automatic Ships Service Telephone Equipment -Type Z-13A, 6 Pairs, Symbol 2873.1.
- SSN 637-604-2159329 - Sliding Door Unit, ECM Room.
- * 401-1973965 - Switch, Door Type IC/DM-1-0.
- * 408-2228164 - Security Device for AIMS KIR-1/TSEC and KIT-1/TSEC Computers.
- 803-4435868 - Ship to Shore Teletype (Landline) Communication Installation.
- 804-5184152 - Window, Passing, for Secure Processing Center.
- * 804-1631627 - Door, Joiner, Sliding Type C (Pressed Panel).
- * 804-1642434 - Door, Metal Joiner, Type H.
- * 804-1642752 - Door, Metal Joiner, Type A.
- * 804-1643220 - Metal Joiner Door, Type L.
- 805-1749004 - Window, Passing, Metal Joiner.
- 805-2218179 - Message Passing Scuttles.
- 805-4629248 - Door, Joiner Metal Honeycomb Core.
- RE 2682997 - SA-734/SG and ID-866/SG Switch Box and Indicator Unit - Outline and Mounting Dimensions and Cabling Diagram.
- RE 2698862 - Physical Security Strap, KI-1, Production Assembly Drawing.

NAVAL ELECTRONIC SYSTEMS SECURITY ENGINEERING CENTER

- 10 D 1675 - Secure Container.
- 10 D 2313 - Secure Container Assembly.
- 10 D 2314 - Secure Container Detail & Weldment.
- 10 D 2315 - Locking Plate Assembly.
- 10 D 2316 - Eccentric Shaft.
- 10 D 2317 - Lock Handle.
- 10 B 2318 - Bumper Plate
- 10 B 2319 - Bumper.
- 10 B 2320 - Shaft Captor.
- 10 B 2321 - Bushing (Shaft-Sleeve).
- 10 B 2322 - Alignment Pin.
- 10 B 2323 - Spacer.
- 10 B 2325 - Mounting Plate.
- 10 C 2327 - Lock Hasp.
- 10 D 2328 - Mounting Bracket (Switching Unit).
- 10 D 2562 - Secure Cover Kit.

UNCLASSIFIED

MIL-STD-1680C(SH)
17 March 1993

- * (U) SPACE AND NAVAL WARFARE SYSTEMS COMMAND
NAVAL ELECTRONIC SYSTEMS COMMAND

NAVELEX
28687-0125013-F - Automated Single Audio
System.

PUBLICATIONS

NAVAL SEA SYSTEMS COMMAND

- * NAVSEA
S9407-AB-HBK-010 - Handbook of Shipboard
Electromagnetic Shielding
Practices.

- * NAVSHIPS
0967-LP-301-7020 - Communication Systems Afloat
Criteria Handbook, Volume 2.

NAVAL TELECOMMUNICATIONS COMMAND

- * NTP-7 - Cryptographic Equipment
Information/Guidance Manual.

NATIONAL SECURITY AGENCY NACSEM 5100 Series -

Compromising Emanations
Laboratory Test Standard
Electromagnetics.

- NACSI-4010 - Routine Destruction and
Emergency Protection of
COMSEC Material.

INSTRUCTIONS

CHIEF OF NAVAL OPERATIONS

- * OPNAVINST 5510.1 - Department of the Navy
Information and Personnel
Security Program Regulation.
- * OPNAVINST C5510.93 - Navy Implementation of
National Policy on Control
of Compromising Emanations.

(U) (Copies of specifications, standards, drawings, and publications required by contractors in connection with specific acquisition functions should be obtained from the contracting activity or as directed by the contracting officer.)

UNCLASSIFIED

MIL-STD-1680C(SH)
17 March 1993

(U) 2.2 Other publications. The following documents form a part of this standard to the extent specified herein. Unless otherwise indicated, the issue in effect on date of invitation for bids or request for proposal shall apply.

A&J Manufacturing Co. Drawing
08060-250-1 - Bar, Locking.

Bendix Field Engineering Drawings
15151ASY3533258-0501 - Control Monitor Group OK-454(V)/WSC Single DAMA.
15151ASY3533259-0501 - Control Monitor Group OK-455(V)/WSC Dual DAMA.

- * Copies of drawings are available from Commander, Space and Naval Warfare Systems Command (Code PDE-106-11), Washington, DC 20363-5100.
- * (U) 2.3 Order of precedence. In the event of a conflict between the text of this document and the references cited herein, the text of this document shall take precedence. Nothing in this document, however, supersedes applicable laws and regulations unless a specific exemption has been obtained.

UNCLASSIFIED

MIL-STD-1680C(SH)
17 March 1993

(U)

3. DEFINITIONS

- * (U) 3.1 Acceptable Hazard. A designation applied to a ship to indicate that, although an Instrumented TEMPEST Survey (ITS) has determined that compromising emanations (CE) are present outside the secure processing center, the TEMPEST signal exploitation vulnerability is minimal, and that correction of the TEMPEST problem is not required.
- * (U) 3.2 Acceptable Risk. A category assigned to a ship that has not had an Instrumented TEMPEST Survey (ITS) to determine its overall TEMPEST posture.
- * (U) 3.3 Armor. A braid of metallic material placed around an insulated conductor or cable for physical protection but also used to reduce interaction and mutual coupling between RED and BLACK cables. (NOTE: This use does not imply equivalence between armored and shielded cable.)
- * (U) 3.4 Assembled equipment. Equipment delivered as an entity, requiring only mounting and connection to external interfaces.
- * (U) 3.5 Battery direct current (d.c.) power supply. The d.c. electrical source of supply which furnishes electric current to an electrical distribution system.
- * (U) 3.6 BLACK. The BLACK designation is applied to facilities, circuits and equipment exclusively involved in handling and processing unclassified plain language or encrypted information in electrical form and are not designated RED.
- * (U) 3.7 Bonding. The process of physically providing a positive, direct and continuous metallic, low-impedance d.c. to radio frequency (RF) path between conducting materials.
- * (U) 3.8 Cipher language. Information that has been processed by a National Security Agency (NSA) approved cryptographic equipment and is in an encrypted unintelligible form, regardless of the original language form.
- * (U) 3.9 Classified Information Processing System(s) (CLIPS). Any equipment, device or system which is electrically powered and processes, converts, reproduces, or otherwise manipulates any form of classified information. The following types of equipment are typical: electrical or electronic typewriters; non-photographic copiers; word processors; composing and editing equipment; video displays; ADP; telecommunications equipment and systems including the teletypewriter, facsimile and cryptographic

UNCLASSIFIED

MIL-STD-1680C(SH)
17 March 1993

(U) equipment; and all interfaces, power sources and interconnecting paths which are part of the system or equipment. CLIPS is a subsystem of a secure electrical information processing system (SEIPS).

- * (U) 3.10 Compromising Emanations (CE). Unintentional intelligence bearing signals which, if intercepted and analyzed, disclose national security information transmitted, received, handled, or otherwise processed by any information processing system.
- * (U) 3.11 Conduit. A metallic pipe, enclosing an insulated conductor or cable, installed to provide physical and TEMPEST protection for the circuits enclosed.
- * (U) 3.12 Control lines. The conductor(s) through which a processing equipment is controlled or receives synchronizing signals (for shipboard examples, clock, clutch, control, and stepping).
- * (U) 3.13 Distribution system. The combination of patching, switching, cabling, battery, and other facilities which connect or control various parts and units of a processing system.
- * (U) 3.14 Electrical perimeter barrier (EPB). The installation boundary that encloses the RED electrical processing system to preclude detection of CE outside the hull of the ship. The electrical perimeter barrier will generally be composed of any of the following:
 - a. Metal structural bulkheads and decks.
 - b. Metal structural non-support bulkheads.
 - c. Metal joiner bulkheads
 - d. Metal doors or scuttles.
- * (U) 3.14.1 The electrical perimeter barrier may or may not share the same structural boundaries with the physical perimeter barrier (see 3.14, 3.33). The physical perimeter barrier provides the physical security to a secure processing center; the electrical perimeter barrier provides the electrical security to the RED electrical processing system within a secure processing center.
- * (U) 3.15 Electronic ground. (see 3.20).

UNCLASSIFIED

MIL-STD-1680C(SH)
17 March 1993

- * (U) 3.16 Exposed remote station. A station having one or more secure voice remote operating positions where the traffic movement of personnel in support of normal operations, or its location outside the superstructure, prohibits invoking the physical security safeguards required for a remote area.
- * (U) 3.17 Fabricated equipment. Equipment requiring on-site assembly to form a unitized (physical or electrical) whole. The prime example of a fabricated equipment is a rack or console composed of assembled equipments. Equipments not receiving prior scrutiny through the full range of applicable military specifications.
- * (U) 3.18 Field Technical Authority (FTA). A person trained and certified by Naval Sea Systems Command (NAVSEA) to conduct shipboard visual TEMPEST inspections.
- * (U) 3.19 Filter. A device designed to pass a selected band of frequencies and attenuate all other frequencies.
- * (U) 3.20 Ground (electronic ground). An electrical reference point of zero potential with respect to all other points of electrical potential in an electrical distribution system. On metallic-hull ships, the ship hull shall be considered ground potential. Bulkheads, decks, and overheads, which are welded or bonded to the ship hull; electronic equipment mounting racks and foundations or other metallic objects which are welded or bonded to the ship hull; and electronic equipment mounting racks, equipment cases, and foundations or other metallic objects which are welded or bonded to these decks, overheads, or bulkheads, shall be considered as an extension of the ship hull. On non-metallic hull ships, the electronic branch ground bus which connects to the main ground bus shall be considered ground potential.
- * (U) 3.21 Grounding. (see 3.7). The process of bonding to ground.
- * (U) 3.22 High level signaling. Signal levels that do not conform with low level signaling. (see 3.27).
- * (U) 3.23 Information processing system configuration record. Plan and elevation views of the equipment configuration of the secure processing center and sketches or narrative description of the secure equipment configuration in remote areas.

UNCLASSIFIED

MIL-STD-1680C(SH)
17 March 1993

- * (U) 3.24 Instrumented TEMPEST Survey (ITS). The testing of an electrical/electromechanical data processor to determine if CE egresses the hull of the ship.
- * (U) 3.25 Isolation device. A device designed with a specified attenuation between inputs or outputs to preclude RED information from coupling to BLACK lines.
- * (U) 3.26 Keying. The function of generating a pulsed d.c. signal.
- * (U) 3.27 Low level signaling. Low levels of voltage and current on signal lines that are between the limits of positive or negative 6 volts (V) with wave shaping in accordance with MIL-STD-188-114. This also includes the digital data signal levels in accordance with MIL-STD-1397 Types A, B, and C, MIL-STD-1553 transformer and direct coupled stubs, and EIA-RS-232.
- * (U) 3.28 National Policy (NP) certification. Certification provided by ITS that a system/equipment does not generate CE which egresses the ship's hull. Certification can be extended to an entire ship.
- * (U) 3.29 Off-line cryptographic equipment. A National Security Agency (NSA) approved processing equipment in which the method of encryption and decryption is not electrically associated with a transmission or reception system.
- * (U) 3.30 On-line cryptographic equipment. An NSA approved processing equipment which encrypts or decrypts information simultaneously with its transmission or reception in electrical form.
- * (U) 3.31 Operating position. A processing equipment or system where information is inserted, displayed, or reproduced. An operating position may consist of, but is not limited to the following:
 - a. Microphone or reproducer combinations, including intercommunications units or consoles, telephone handsets, chest sets, headsets, and voice selector consoles.
 - b. Teletypewriters (transmit or receive) or combinations thereof.

UNCLASSIFIED

MIL-STD-1680C(SH)

17 March 1993

- (U) c. Electronic or other information and data display or processing equipment.
 - d. Television cameras and receivers.
 - e. Facsimile transmit or receive combinations.
 - f. Control consoles.
 - g. Data input or output devices, data recording and reproducing equipment, machine language producing equipment and other devices used with computers and other processing equipment. Machine language producing equipment includes equipment such as typewriters, word processors, and composing and editing equipment.
- * (U) 3.32 Physical barrier. As distinguished from physical perimeter barrier, a physical barrier is an obstruction, such as a partition, half partition, file cabinets, safe lockers, or expanded metal bulkhead that will provide the necessary physical separation from operating positions of lower classification. The intent is to provide a permanent or semipermanent barrier which will prevent operators from inadvertently introducing classified messages into circuits of lower security levels.
- * (U) 3.33 Physical perimeter barrier. The physical perimeter barrier controls access to security areas and will normally consist of permanently installed partitions, bulkheads, decks, overhead, and approved accesses to bound and isolate the area.
- * (U) 3.34 Physical security. Security measures that physically protect classified information and materials (including cryptographic equipment) from compromise when operating a RED processing system. This includes tactile, visual and aural access.
- * (U) 3.35 Plain text. Intelligible text or signals which have meaning and which can be read or acted upon without the application of any decryption.
- * (U) 3.36 Plain/cipher (p/c) secure voice. (see 3.51)
- * (U) 3.37 Power line. Conductor intended for the transmission of primary alternating current (a.c.) power.
- * (U) 3.38 Processing equipment. Equipment or device which reproduces information from, converts information to, or otherwise operates upon information in electrical form. The

UNCLASSIFIED

MIL-STD-1680C(SH)
17 March 1993

(U) following types of equipment are typical: telecommunications equipment, video displays, and systems including the teletypewriter, facsimile, and cryptographic equipment.

- * (U) 3.39 Processing system. A combination of processing equipment and its associated distribution system.
- * (U) 3.40 RED. A designation applied to telecommunications circuits, components, equipment and systems which handle classified plain text or other information which requires protection during electrical transmission and to areas in which such information exists. In ships this designation also applies to primary power circuits, audio and d.c. signal circuits, control circuits and ground return conductors serving those cryptographic and subscriber terminal equipments, which are designated RED. It is also applied to junction boxes, terminal boxes, distribution frames, conduit, ducts, patching and switching panels, power distribution panels (both a.c. and d.c.) and other ancillary devices which serve the aforementioned conductors and equipment.
- * (U) 3.41 RED/BLACK electrical signal interface device. A unit within a system which has, or may have both RED and BLACK electrical information resident at the same time. An approved interface device has been tested and found to have adequate isolation between ports or channels to prevent the RED information from being coupled into the BLACK distribution system. A listing of approved RED/BLACK interface devices is provided in Appendix D, paragraph 50.2.
- * (U) 3.42 Restricted area. An area where classified information is stored or used. Only those persons whose duties actually require access and who have been granted appropriate security clearance shall be allowed freedom of movement within the area. The movement of other persons admitted to the area shall be controlled by an escort.
- * (U) 3.43 RED high level electrical signal distribution system. A RED system not defined as a RED low level electrical signal distribution system.
- * (U) 3.44 RED low level electrical signal distribution system. A system wherein the signal levels comply with the following:
 - a. RED equipment and systems specifically included for the standard interface (low level) identified in MIL-STD-188-114. It may include RED processing equipment employing RED high level keying or signaling, but such

UNCLASSIFIED

MIL-STD-1680C(SH)
17 March 1993

- (U) keying or signaling levels are not part of and do not extend into the electrical signal distribution system without conversion to RED low level signal levels.
 - b. RED baseband video closed circuit television (CCTV) distribution systems (see Appendix B).
 - c. RED balanced audio systems with audio levels that do not exceed 0 decibel (dB) as referred to 1 milliwatt (dBm).
- * (U) 3.45 Red marking. Color identification assigned and applied to cables associated with a RED high level system.
- * (U) 3.46 Remote area. An area physically separated from a secure processing center or a secure remote area and containing one or more RED processing equipment, or cryptographic equipment that has its own individual physical security safeguard against unauthorized removal, or both.
- * (U) 3.47 Secure. Capable of protecting classified information.
- * (U) 3.48 Secure Electrical Information Processing System (SEIPS). The total combination of classified information processing systems (CLIPS) on board a ship comprises the SEIPS. A ship has only one SEIPS regardless of the number of CLIPS on board.
- * (U) 3.49 Secure processing center (SPC). An area with the characteristics, functions and identified spaces as follows:
 - a. Functions.
 - (1) A processing and distribution center for a RED processing system; and containing cryptographic equipment that does not have its own individual physical security safeguard against unauthorized removal, or
 - (2) A Special Intelligence (SI) area containing RED processing equipment.
 - b. Characteristics.
 - (1) It shall have a clearly-defined electrical and physical perimeter barrier.
 - (2) The electrical perimeter barrier shall enclose at least that area containing the RED processing equipment.

UNCLASSIFIED

MIL-STD-1680C(SH)
17 March 1993

- (U) (3) The physical perimeter barrier shall enclose at least that area requiring physical security for classified information.
- (4) The electrical or physical perimeter barrier may enclose an area not requiring electrical or physical security in order to consolidate operator and maintenance functions (such as having the Radio Transmitter room or Facilities Control contiguous to the Communication Center).

c. Mandatory secure processing centers.

- (1) Communication Center.
- (2) Secure Teletype Area.
- (3) Ship Signal Exploitation Space (SSES).
- (4) Outboard Operations Room.
- (5) Outboard Communications Room.
- (6) Joint or CV Intelligence Center.
- (7) Other specifically-designated spaces.

- * (U) 3.50 Secure remote area (SRA). An area with the functions and characteristics as follows:

a. Functions.

- (1) An area physically separated from a secure processing center in which classified voice or data is available and where either:
 - (a) One or more RED processing equipment(s) having RED signal lines which do not have a disconnect capability located within a secure processing center or another secure remote area or,
 - (b) RED processing equipment (crypto equipment, disk drive, etc) that does not have its own individual physical security safeguard against unauthorized removal.
- (2) An area physically separated from a secure processing center where there is the possibility of obtaining classified information from electronic storage when the space is unmanned (for example, obtaining a printout, visual display or other reproduction from computer memory, disk or magnetic tape).

b. Characteristics.

- (1) It shall have a clearly defined physical perimeter barrier.

UNCLASSIFIED

MIL-STD-1680C(SH)
17 March 1993

- (U) (2) The physical perimeter barrier shall enclose at least that area requiring physical security for classified information.
- * c. Examples of Secure Remote Areas are:
 - (1) CIC and EW Room where the AN/SLQ-32A(V) or AN/SLQ-17(V) is installed.
 - (2) CIC, TOMAHAWK Equipment and Computer Rooms where TOMAHAWK is installed
 - (3) Designated sonar spaces.
 - * (4) CIC where JOTS NTCS-A is installed.
 - (5) Meteorological Room where AN/UMK-3 SMOOS/TESS-3 is installed.
- * (U) 3.51 Secure voice. A RED voice system, isolated from other systems in accordance with this standard, which may be subcategorized as follows:
 - a. A system which operates in the secure mode only. Such a system may include Fleet Satellite Communications (FLTSATCOM) secure voice using CV-3333/UG and TSEC/KG-36, and wideband secure voice using equipment that does not employ p/c option (for example, TA-790/U).
 - * b. A p/c system which may be operated in the secure or nonsecure mode. Such a system includes, but is not limited to, secure voice and the single audio system using equipment that employ p/c option.
- * (U) 3.52 Shield. A solid or braided covering of nonferrous conductive material, preferably copper, used to completely encompass, throughout its length, an insulated conductor or conductors to provide high levels of RF attenuation to potential sources of CE.
- * (U) 3.53 Signal distribution system. The combination of patching, switching, cabling, battery, and other circuit facilities, less primary power, which connect or control various parts and units of a processing system.
- * (U) 3.54 Signal lines. Conductors intended for the transmission of information.
- * (U) 3.55 Signaling. Signaling is the function of distributing a pulsed d.c. signal.
- * (U) 3.56 SPAWAR TEMPEST-approved equipment. (Previously identified as CHNAVMAT TEMPEST-approved equipment.) An equipment

UNCLASSIFIED

MIL-STD-1680C(SH)
17 March 1993

(U) or unit of a system approved by Commander Space and Naval Warfare Systems Command (COMSPAWARSYSCOM) designated technical agency for shipboard installation in a particular system application, as noted herein, using low level installation criteria. The definition does not imply that the equipment has been subjected to or has passed NACSIM 5100 and/or series NSTISSAM TEMPEST/1-91 testing.

- * (U) 3.57 Subsystem. A subordinate system of the ship's total information processing system which identifies a group of equipment utilized in a particular mode and with certain capabilities. These subsystems are fully identified in Publication NAVSHIPS 0967-LP-301-7020.
- * (U) 3.58 TEMPEST. An unclassified short name referring to investigations and studies of compromising emanations.
- * (U) 3.59 TEMPEST related installation criteria. Those installation measures which serve to diminish the possibility of CE problems.
- * (U) 3.60 TSEC. The abbreviation for telecommunications security. When affixed to short titles, it indicates material for which the security and the use are controlled by the NSA.
- * (U) 3.61 Visual TEMPEST Configuration Control Inspection (VTCCI). A VTCCI consists of a visual TEMPEST inspection and an information processing system configuration record.
- * (U) 3.62 Visual TEMPEST Inspection (VTI). A visual inspection of a secure information processing facility which is conducted by a certified FTA inspector for purposes of evaluating the facilities compliance or non-compliance with the installation criteria herein. A VTI is conducted only as part of a VTCCI or as an inspection of corrected discrepancies.

UNCLASSIFIED

MIL-STD-1680C(SH)
17 March 1993

(U) 4. GENERAL REQUIREMENTS

(U) 4.1. TEMPEST-related installation requirements. The installation standards herein shall be implemented as specified to reduce or eliminate inadvertent egression of CE, to the extent required to conform to applicable criteria established by OPNAVINST C5510.93().

(U) 4.1.1. Signaling levels. In new construction ships and active fleet ships undergoing a major alteration to the exterior communication system, the secure electrical information processing system shall be installed using a RED low level signaling distribution system.

(U) 4.2. Limitations. This standard does not, by itself, constitute an authorization or requirement for alterations to ships. This standard shall not arbitrarily be applied to systems and spaces except for those systems and spaces noted in this standard, or other specific NAVSEA guidance documents.

(U) 4.3. Supplementary standards. Appendices to this standard provide the following data:

- Appendix A - Special Intelligence Space Installations.
- Appendix B - Closed Circuit Television Systems.
- Appendix C - Fiber Optic Distribution Systems.
- Appendix D - SPAWAR TEMPEST-Approved Equipment and Systems.
- Appendix E - Combat System Ship Land Based Test Site.
- Appendix F - Inspection Check-off sheets.
- Appendix G - Sample Inspection Reports.
- Appendix H - Boats and Craft.
- Appendix I - Illustrations.
- Appendix J - Micro/Mini Computer Systems.

(U) 4.4. Cryptographic equipment in a portable configuration. There are no TEMPEST-related installation requirements for cryptographic equipment in a portable configuration. This includes, but is not limited to: cryptographic attachments to portable radio sets such as hand-held, belt-worn or contained within a protective helmet; vehicular-mounted equipment as used in a flight or hangar deck application; and, cryptographic devices used to load or fill a cryptographic system.

(U) 4.5. Unique systems. Unique systems for which this standard cannot be applied shall be submitted to NAVSEA (Code 06K222) for development of specialized criteria.

UNCLASSIFIED

MIL-STD-1680C(SH)
17 March 1993

(U) 5. DETAILED REQUIREMENTS.

(U) 5.0 General. The requirements for primary TEMPEST-related installation standards (see 5.1), support of primary TEMPEST-related installation standards (see 5.2) and physical and operational security installation standards (see 5.3) are separately grouped. Unless otherwise specified, each detailed requirement shall be applicable to new construction ships of all classes and new installations in active fleet ships.

(U) 5.1 Primary TEMPEST-related installation standards. The detailed requirements of this section shall be applicable to all SEIPS in all locations unless otherwise specified within the individual paragraph. A system shall be considered to be high level if any RED high level signaling is present in the distribution system. A RED low level signal distribution system allows for equipment employing RED high level keying/signaling but such keying/signaling levels are not part of and do not extend into the signal distribution system without conversion to RED low level signal levels.

(U) 5.1.1 RED and BLACK signal and control line interfaces. Equipment having a RED and BLACK signal and control line interface is an equipment which has one or more connection(s) to a RED system (RED signal lines or RED control lines, or both) and one or more connection(s) to a BLACK system (BLACK signal lines or BLACK control lines, or both). In a p/c secure voice application, any equipment having two or more p/c secure voice signal (transmit and receive) inputs or outputs is a RED and BLACK signal and control line interface. An equipment having a RED and BLACK signal and control line interface shall be limited to the following categories:

- a. Isolation devices (see 3.25) having SPAWAR TEMPEST-approval. Appendix D, 50.2, includes equipment in this category.
- b. Isolation devices (see 3.25) not having SPAWAR TEMPEST-approval but have only low level signal and control interfaces. Requirements for these devices are in Appendix D, 40.1.c.
- c. Cryptographic equipment, as an NSA-approved item, does not require SPAWAR TEMPEST-approval. See 5.1.7 for constraints in the use of clock to cryptographic equipment.

UNCLASSIFIED

MIL-STD-1680C(SH)

17 March 1993

- (U) d. Processing equipment shared between RED and BLACK signal distribution systems shall have the distribution systems isolated from each other with a SPAWAR TEMPEST-approved isolation device listed in paragraph 50.2 of Appendix D (for example, SA-734/SG, SA-2371/SG, SB-1299/USQ-20, SB-3372/US and SB-2626/U).
- e. Equipment in a. or c. installed for the purpose of technical or operational evaluation, or both, do not require prior SPAWAR TEMPEST-approval for the period of the evaluation.
- f. RED processing equipment may receive signal or control information directly from a BLACK navigation system (for example, own ship speed, own ship head, roll, pitch, omega, loran, satellite and wind direction and speed).
- g. RED processing equipment may directly interface a time-code generator or display system. Frequency standard distribution systems shall only interface a RED system via a time-code generator or display system or via a SPAWAR TEMPEST-approved isolation device.
- h. RED processing equipment may directly interface a BLACK AN/SLA-10() Blanker-Video Mixer Group.
- i. Junction boxes installed as specified in 5.1.9.1.

(U) 5.1.2 Primary power.

- * (U) 5.1.2.1 RED primary power. RED primary power shall be derived from power line filters. Such filters may be used to serve a multiple number of equipments or a single equipment. RED power for equipment at a remote operating position shall be obtained from a filtered source located at the remote area or extended from the secure processing center. The following systems and equipment shall be connected to RED primary power:
 - a. RED electrical processing equipment that is not SPAWAR TEMPEST-approved and has one or more RED high level signal or control interfaces.
 - * b. RED low level electrical processing equipment that requires RED power as a result of TEMPEST testing. These equipments are listed in Appendix D, 50.4.

UNCLASSIFIED

MIL-STD-1680C(SH)
17 March 1993

- * (U) c. RED low level processing equipment that is not listed in Appendix D, Sections 50.1, 50.2, or 50.3 shall be installed on RED power unless approval for connection to BLACK power is given by NAVSEA Code 03K222.

(U) 5.1.2.2 BLACK primary power. The following systems and equipment shall be connected to BLACK primary power:

- a. BLACK electrical processing equipment.
- b. Cryptographic equipment.
- c. RED SPAWAR TEMPEST-approved equipment and systems.
- d. RED electrical processing equipment that is not SPAWAR TEMPEST-approved, but has only low level signal and control interfaces. Requirements for these equipments are in Appendix D, 40.1.c.

(U) 5.1.2.3 Individual power line filters. An individual power line filter, installed adjacent to the equipment, shall be used to provide power to electrical processing equipment that is shared between the RED high level and BLACK electrical signal distribution systems. These filters shall be supplied from BLACK primary power. The filter shall not be used to supply power to any other equipment except an associated ID-866/SG Indicator Light (see 5.2.3).

- * (U) 5.1.2.4 Power filters. Power filters shall provide 100 dB of attenuation within the stopband of 14 kilohertz (kHz) to 1 gigahertz (GHz). Filters shall meet this requirement as tested in accordance with MIL-STD-220 or as indicated by vendor specifications. Filters shall be installed in each leg of the power circuit. The ampere rating of the filter shall be greater than the total connected load. The RED power source may be derived from power line filters serving a multiple number of equipments, or from an individual power line filter serving a single equipment, except as otherwise specified herein. Individual power line filters should be installed as close as practical to the equipment requiring RED power to minimize RED cable length. Power line filters supplying a multiple number of equipments via a power distribution panel shall be installed within the secure processing center, secure remote area or remote areas. The RED power filter shall derive power from an unfiltered BLACK power source. Filter discharge units installed with power line filters as a personnel safety device have no TEMPEST-related security significance, and are acceptable.

UNCLASSIFIED

MIL-STD-1680C(SH)
17 March 1993

(U) 5.1.3 Battery. The RED battery shall be separate and independent of the BLACK battery. Solid state rectifier power supplies shall be used for RED battery in lieu of power supplies using mercury vapor rectifiers or gas-filled regulator tubes.

* (U) 5.1.4 Rotary or tone/pulse dial analog telephone installations in a secure processing center. In surface ships, rotary or tone/pulse dial analog telephones having a shore-tie capability, installed within the electrical perimeter barrier of a secure processing center, shall have their lines filtered. (Digital telephones, the STU-III, AN/STC-1 and AN/STC-2 for example, if installed within the EPB of a ship with a RED high level signal distribution system, shall have their signal lines shielded, but not filtered.) Filter installation shall comply with the following:

- a. Filter characteristics and installation shall be in accordance with the following:
 - (1) Telephone line filters shall provide 100 dB of attenuation within the stopband of 14 kHz to 1 GHz, as tested in accordance with MIL-STD-220 or as indicated by vendor specifications.
 - (2) Filters with exposed terminals shall be enclosed within a metal container.
 - (3) The filters shall be installed within the center at the point of cable penetration; the external cable shall be brought through the electrical perimeter barrier directly into the filter.
 - (4) For non-metallic hull ships, filters shall be located for installation convenience within the center.
- b. In a center having a RED high level signal distribution system, all conductors from the telephone passing through the perimeter shall be filtered; selection of filters shall provide continuity for both ringing and transmission circuits if required.
- c. In a center having a RED low level signal distribution system, only the voice signal line need be filtered.

UNCLASSIFIED

MIL-STD-1680C(SH)
17 March 1993

* (U) 5.1.4.1 Location of rotary tone/pulse dial analog telephones with a shore-tie capability. In surface ships, the cradle for rotary or tone/pulse dial analog telephones having the capability of connection to a shore-tie, shall be located a minimum of 3 feet from low level and 6 feet from high level RED processing equipment (except for remote units of a secure voice system) in secure remote areas. If required separation cannot be achieved, a filter, in compliance with paragraph 5.1.4.a, (1) and (2) shall be installed in a convenient location a minimum of 6 feet from the RED processing equipment. Telephones with audio-to-digital conversion, such as the STU-III, AN/STC-2() or its commercial equivalent which have a shore-tie capability, whose cables are run within 6 feet of RED high level processing equipment, shall have their cables shielded, but do not require a filter or separation from RED processing equipment.

(U) 5.1.5 Landline terminations for surface ships. The landline termination shall be installed and terminated as shown on Drawing 803-4435868, Figures 1 and 2 of Appendix I, and as follows:

* a. The following filter units or NAVSEA approved fiber optic isolators shall be installed in the teletype landlines:

Audio/tone circuits:	F-1032/SG Radio Interference Filter.
D.C. circuits:	F-1033/SG Filter Isolation Assembly.

b. The case of the filter units shall be bonded to ground (see 5.2.14.14).

c. Where the filter units are connected to switchboards or communication patching panels within the electrical perimeter barrier, the filters shall be mounted at the point of cable penetration on the outer side of the electrical perimeter barrier of the secure processing center. Where the filter units are connected to switchboards or communication patching panels outside of the electrical perimeter barrier, the filters shall be mounted, for installation convenience, outside the electrical perimeter barrier but on or within the physical perimeter barrier of the secure processing center.

UNCLASSIFIED

MIL-STD-1680C(SH)
17 March 1993

(U) 5.1.6 Parallel data. Processing equipment and systems that have a data input or output in a parallel data format are classified in two categories:

- a. Equipment which form the core of the Navy Tactical Data System (NTDS). Equipment in this category includes the AN/UYK-7(V), AN/SYA-4(V), AN/UYA-1(V), AN/UYA-4(V) and CP-642()/UYK. These equipment or systems shall be in compliance with 5.1.6.2.
- b. Equipment not identified in a. above, and which exchange data with the NTDS, directly interface the NTDS computer or are a part of or interface other processing systems. Equipment in this category includes but is not limited to the AN/SRD-19, AN/UYK-20(V), AN/UYK-43, AN/UYK-44, AN/UYQ-21(V) and AN/UYQ-23(V). These equipment or systems shall conform to the TEMPEST-related and physical security installation requirements as specified herein.

(U) 5.1.6.1 NTDS communication section. The NTDS communication section is considered to be that portion of NTDS that is processed in serial stream, including the serial-parallel converter equipment. The NTDS communication section (for example, Link 14) shall conform to the TEMPEST-related and physical security installation requirements specified herein (see Figure 3, Appendix I).

(U) 5.1.6.2 NTDS parallel data section. Within the parallel data section of the NTDS (see Figure 3, Appendix I) the following shall be applied:

- a. The RED data section cables shall be considered RED low level cables for purposes of cable separation.
- b. Normal NTDS engineering practices of utilizing overall shielding and bonding shall be considered satisfactory as a minimum criteria.
- * c. The TSEC/KG-40 shall be bonded to ground in accordance with 5.2.14.13.c and 5.2.14.13.g.

(U) 5.1.7 Isolation of clocking and control circuits. When common clocking or control (master clock, modem clock, timing control) is used to provide timing or control for both RED and BLACK processing equipment, these lines shall be decoupled by an approved isolation device. A RED processing equipment, listed in 50.2 Appendix D as a SPAWAR TEMPEST-approved RED/BLACK signal interface, is an approved isolation device. Certain equipment

UNCLASSIFIED

MIL-STD-1680C(SH)

17 March 1993

(U) that is not SPAWAR TEMPEST-approved may be used as an isolation device subject to the requirements of 40.1.c, Appendix D.

(U) 5.1.8 Equipment.

* (U) 5.1.8.1 Common equipment cabinets. On surface ships, RED and BLACK processing equipment may be installed in the same electronic equipment cabinet or rack only if the original enclosures of both the RED and BLACK processing equipments have not been removed. On submarines, the RED and BLACK equipments may be installed in electronic cabinets or racks as required by space limitations.

(U) 5.1.8.2 Relays and drivers. In non-metallic hull surface ships, selector magnet drivers and other relay devices shall not be installed to make and break high level currents in the RED high level electrical signal distribution system, unless such devices are part of the cryptographic equipment. In metallic hull surface ships, selector magnet drivers and isolation relays may be installed in the RED electrical signal distribution system if enclosed in a metal case, and the power, cable and bonding are in conformance with this standard.

* (U) 5.1.9 Cable-connecting enclosures. RED terminal boxes, junction boxes, power distribution panels and other cable connecting enclosures shall maintain the integrity of the penetrating cable shield or armor with solid surface metal enclosures. This requirement is applicable to RED and BLACK cable connecting enclosures within a secure processing center of a metallic hull surface ship having a RED high level signal distribution system.

* (U) 5.1.9.1 Shared junction boxes and cable entrance boxes. Junction boxes may be used as an intermediate connection point for cables containing both RED low level (for example, p/c secure voice or single audio systems) and BLACK circuits. Cable entrance boxes containing both RED low level and BLACK circuits may be used for fanning cable conductors and their shields for an orderly penetration of a group of individual equipments (such as secure voice matrix switches). Cables and conductors of a shared junction box or cable entrance box shall conform to the following:

* a. The lay of a twisted pair shall be retained to the point of connection on the terminal strip.

UNCLASSIFIED

MIL-STD-1680C(SH)
17 March 1993

- * (U) b. The shield over a twisted pair shall be retained within the box to the point of connection on the terminal strip. The length of unshielded conductor at the point of termination shall be kept as short as practical. Where an existing box has the shield(s) bonded to ground at or near the point of cable entry, a sleeve-braid shield shall be added over the wire pairs and bonded to ground at each end. If the twist has been removed from the wire pair, it shall be restored prior to adding the shields.
- c. Within a junction box, the shield shall be bonded to ground at the terminal strip (see 5.2.14.19). Within a cable entrance box, the shield shall be bonded to ground at the equipment being served by the cable entrance box in accordance with the methods of 5.2.14.19.
- d. Conductors within a junction box shall be as short as possible yet be long enough to reach any terminal connection.

(U) 5.1.10 Cable.

- * (U) 5.1.10.1 BLACK shielded cable. BLACK cables serving and terminating within the electrical perimeter barrier of a secure processing center of a metallic hull surface ship having a RED high level electrical signal distribution system shall be shielded, except for lighting and receptacle cables connected to BLACK filtered power and telephone cables connected to perimeter-mounted filters.
- * (U) 5.1.10.2 RED shielded cable. RED cables in all locations shall be shielded, except as permitted in Appendix J. This requirement is not applicable to RED fiber optic cables.
- * (U) 5.1.10.3 Large power cable exception. Primary a.c. power cables are exempted from the requirements of 5.1.10.1 and 5.1.10.2 where shielded cables of adequate carrying capacity (generally greater than 15A) are not available in accordance with MIL-C-915, MIL-C-24640 or MIL-C-24643, in which case they shall be armored or contained in metal conduit or RF-tight flexible conduit.

UNCLASSIFIED

MIL-STD-1680C(SH)

17 March 1993

(U) 5.1.10.4 Secure voice cables. Cables and conductors serving secure voice processing equipment shall be isolated in the following manner:

- a. Transmit and receive audio lines shall be balanced twisted pairs with each pair non-ferrous shielded, and the shields insulated from each other. Where the transmit pair and associated transmit control wires are contained in one cable, an overall non-ferrous shield may be used provided the associated receive audio is contained in a separate twisted shielded pair cable.
- b. When a multi-circuit cable is used, each transmit and receive audio twisted pair shall be non-ferrous shielded with all shields insulated, and with an overall insulating sheath.

(U) 5.1.10.5 Armored cable. There is no requirement for armored cable within this standard except as specified in 5.1.10.3. Armored cable, if used or terminated within the electrical perimeter barrier of a secure processing center of a metallic hull surface ship having a RED high level electrical signal distribution system, shall have the armor bonded to ground. The use of armored cable does not imply equivalence of armored and shielded cable.

(U) 5.1.10.6 Cables not serving a secure processing center. New installation of cables other than those terminating within the electrical perimeter barrier of a secure processing center shall be routed around the electrical perimeter barrier, unless totally enclosed in RF-tight metal duct or conduit. The metal duct or conduit shall be bonded to ground at the points of penetration of the electrical perimeter barrier. This requirement is applicable only to a metallic hull surface ship having a RED high level electrical signal distribution system.

- * (U) 5.1.10.7 Waveguide and rigid coaxial cables. New installations of waveguide and rigid coaxial cables that are not at ground potential at the points of penetration of the electrical perimeter barrier shall be routed around the electrical perimeter barrier of a secure processing center having a RED high level signal distribution system, unless totally enclosed within an RF-tight, solid-surface metallic trunk. Access plates, if required, shall maintain the shielding integrity of the trunk. The metallic trunk shall be bonded to ground at the points of penetration of the electrical perimeter barrier.

UNCLASSIFIED

MIL-STD-1680C(SH)
17 March 1993

* (U) 5.1.10.8 Rotary or tone/pulse dial telephone line cables. Rotary or tone/pulse dial telephone line cables connected to telephones having a shore tie capability routed through, but not terminating within the electrical perimeter barrier of a secure processing center, shall be removed or enclosed in RF-tight metal duct or conduit which is bonded to ground at the points of penetration of the electrical perimeter barrier. This requirement is applicable only to a metallic hull surface ship having a RED high level electrical signal distribution system.

* (U) 5.1.10.9 Cable splices. Splicing of RED cables shall maintain the electrical and physical properties of the cable. Splicing of RED cables outside of a secure processing center, secure remote area, or remote areas shall be avoided by using a single continuous cable run.

(U) 5.1.10.10 Determination of RED high level and low level cables. Primary power cables serving equipment that process RED high level signaling shall be considered as a RED high level cable for purposes of cable separation; other RED primary power cables that connect to the same power panel serving the above equipments shall also be considered as RED high level cables. RED primary power cables serving equipment requiring RED power and that processes only RED low level signaling shall be considered as RED low level cables for purposes of separation providing the source of the RED primary power (filter or power panel) is exclusively for equipment processing RED low level signaling, and has no RED primary power interconnection with RED equipment that processes RED high level signaling. RED signal and control cables that connect to RED low level signal inputs or outputs of RED electrical processing equipment, whether SPAWAR TEMPEST-approved or not, and to secure voice equipment shall be regarded as RED low level system cables for purposes of cable separation. A cable containing an unbalanced analog or audio (voice) signal is a high level cable for purposes of cable separation. Other RED signal and control cables shall be considered as RED high level system cables for purposes of cable separation, with the following exceptions:

a. The interconnecting cables supplied with the equipment between an electrical service assembly and a RED low level teletypewriter.

* b. The signal line between an audio amplifier and a loudspeaker.

UNCLASSIFIED

MIL-STD-1680C(SH)
17 March 1993

- * (U) c. The interconnecting unbalanced audio cables between the SA-2216/U Audio Control and its associated audio distribution box and tape recorders.

(U) 5.1.10.11 RED cables external to the ship hull. RED high level system cables external to the ship hull shall be installed in conduit. The conduit shall be bonded to ground at the hull penetration points.

(U) 5.1.10.12 RED and BLACK conductor separation. Cables containing conductors connected to a RED high level electrical distribution system shall not contain conductors connected to a BLACK electrical distribution system. Cables containing conductors connected to a RED low level electrical distribution system may also contain conductors connected to a BLACK electrical distribution system providing the RED conductors are shielded individually or overall from the BLACK conductors.

(U) 5.1.10.13 Separation of RED cables parallel to other cables. On surface ships, parallel runs between RED high level system cables and other cables shall have a minimum separation as follows:

- a. 4 inches from shielded or armored cables containing BLACK, RED low level, p/c secure voice signals.
- b. 4 inches from unshielded or unarmored lighting cables connected to BLACK filtered power, telephone cables connected to perimeter-mounted filters.
- c. 3 feet from BLACK unshielded or unarmored cables.

No separation is required between RED low level, p/c secure voice and BLACK cables.

- * (U) 5.1.10.14 Separation of RED and BLACK cables at crossover points. A crossover shall be made as near to 90 degree right angles as possible. Any crossover having an angle of less than 75 degrees shall be considered a parallel run.

(U) 5.1.10.15 Separation of RED cables at crossover to other cables. On surface ships, a minimum separation between RED high level system cables and other cables at crossover points shall be:

- a. 1 inch from shielded or armored cables containing BLACK, RED low level, p/c secure voice signals.

UNCLASSIFIED

MIL-STD-1680C(SH)
17 March 1993

- (U) b. 1 inch from unshielded or unarmored lighting cables connected to BLACK filtered power, telephone cables connected to perimeter-mounted filters.
- c. 6 inches from BLACK unshielded or unarmored cables.

No separation is required between RED low level, p/c secure voice and BLACK cables.

(U) 5.1.10.16 Cables shared between RED High Level and BLACK electrical distribution systems. On surface ships, a cable shared between the RED High Level and BLACK electrical distribution systems (for example, from an SA-734/SG Switch Box to a teletypewriter) shall be separated from all other cables in accordance with 5.1.10.13 through 5.1.10.15.

(U) 5.1.10.17 Separation of RED and BLACK portable cables. Portable cables associated with items such as handsets, headsets, microphones or test equipment are excluded from the separation requirements of 5.1.10.13 through 5.1.10.16. The foregoing shall not be used to circumvent the separation requirements for "fixed" cable runs.

(U) 5.1.10.18 Conduit to alleviate cable separation requirements. That part of a cable enclosed in conduit is exempt from the cable separation requirements of 5.1.10.13 through 5.1.10.16. Separation shall be determined from the nearest exposed portion of RED cable. Conduit shall be bonded to ground at each end (see 5.2.14.23).

(U) 5.1.10.19 Conductive paths for signal and control lines. Within the EPB of an SPC having a RED high level electrical signal distribution system, RED signal and control lines, and BLACK signal and control lines, shall be composed of twisted pairs of conductors, and shall not use the shield, armor or the ship hull for the electrical return path. As an exception, the shield on coaxial cables shall be used as the electrical return path if required for system operation. On metallic hull surface ships with a RED low level electrical signal distribution system, submarines, and non-metallic hull ships, this requirement is applicable to the RED signal and control lines only.

(U) 5.1.11 Secure Voice.

(U) 5.1.11.1 Objective. The overall secure voice system shall be accorded the standards for a p/c secure voice subsystem, unless otherwise specified herein. The secure voice system shall be isolated from all other systems as specified herein.

UNCLASSIFIED

MIL-STD-1680C(SH)
17 March 1993

* (U) 5.1.11.2 Line and signal levels. The RED analog voice signal line shall be a 600-ohm balanced system. The audio level shall not exceed 0 dB as referred to 1 milliwatt (dBm), except in the signal line between an audio amplifier and a loudspeaker.

(U) 5.1.11.3 Signal processing levels. When the secure voice system is capable of p/c operation, the RED signal level (see 5.1.11.2) shall be not greater than the BLACK signal level.

(U) 5.1.11.4 Isolation between circuits. Secure voice system equipment, units, and parts shall offer a minimum of 80 dB isolation in the frequency range of 300 to 10,000 Hz between the circuit in which they are utilized and any transmit audio or control circuit on the ship.

* (U) 5.1.11.5 Plain/cipher secure voice signal line filters. The p/c secure voice send processing equipment (for example, TA-970()/U) that is within 6 feet of high level RED processing equipment and 3 feet of low level RED processing equipment shall have a signal line filter in the transmit signal lines in a convenient location a minimum of 6 feet from RED processing equipment. The filter shall provide 100 dB of attenuation within the stopband of 14 KHz to 1 GHz.

(U) 5.1.11.6 Signal and control cables. Secure voice signal and control cables are considered the same as RED low level cables for the purpose of cable separation. Secure mode only subsystems previously installed as RED high level systems will not require retrofit. When a secure mode only subsystem is reconnected to BLACK primary power or converted to a p/c subsystem, signal and control cables previously installed with RED high level system cables shall be separated from those high level cables. This requirement is not applicable to submarines.

* (U) 5.1.11.7 Multichannel magnetic tape recorders in p/c secure voice. A multichannel magnetic tape recorder installed in a surface ship and used to record p/c secure voice communication channels shall:

- a. Use individually shielded twisted pair cables for audio input lines.
- b. Be located not less than 6 feet from BLACK signal processors such as unfiltered radio telephones, modems, radio transmitters and switchboards.

UNCLASSIFIED

MIL-STD-1680C(SH)
17 March 1993

5.1.12 Non-metallic hull ship keying and signaling.

- * (U) 5.1.13 Bonding. Cryptographic equipment, RED electrical processing equipment, RED cable shields and armor, power filters, telephone filters, and landline filters shall be bonded to ground. Spare conductors in RED cables which penetrate the electrical perimeter barrier of the secure processing center shall be connected to ground at each end of the cable. Bonding requirements are applicable to BLACK electrical processing equipment and BLACK cable shields, armor and spare conductors within the electrical perimeter barrier of a secure processing center on a metallic hull surface ship having a RED high level electrical signal distribution system (see 5.2.14 through 5.2.14.25).

- * (U) 5.1.14 Location of BLACK facsimile equipment. In surface ships, non-SPAWAR TEMPEST-approved facsimile equipment connected to a telephone with shore-tie capability shall be located a minimum of 3 feet from low level and 6 feet from high level RED processing equipment.

UNCLASSIFIED

UNCLASSIFIED

UNCLASSIFIED

MIL-STD-1680C(SH)
17 March 1993

(U) 5.2 Support of primary TEMPEST-related installation standards. The detailed requirements herein support the TEMPEST-related installation requirements of 5.1 in identifying the methods and procedures by which the basic TEMPEST-related requirement is to be fulfilled.

(U) 5.2.1 RED primary power distribution panel location. Fuse and primary a.c. power distribution panels serving RED electrical processing systems on surface ships shall be located within secure processing centers, secure remote areas or remote areas. Fuse and primary a.c. power distribution panels within:

- a. Secure processing centers may provide power distribution to secure remote areas and remote areas.
- b. Secure remote areas may provide power distribution to remote areas.

* (U) 5.2.2 Equipment power connection. Processing equipment requiring RED power shall be permanently connected to a RED power source and shall not be connected to a lighting panel. BLACK equipment contained in electronic equipment cabinets or racks may employ the cabinet blower power switches or the open rack power strip switches as the equipment power disconnect. If the number of equipment exceeds the number of blower or power strip switches, additional switches should be added. A common power cable from the distribution panel may serve several disconnect switches in the cabinet.

* (U) 5.2.3 Primary a.c. power for ID-866/SG. The ID-866/SG Indicator Light, when used to show the status of a shared RED/BLACK processing equipment, shall derive primary a.c. power from the shared equipment to assure the ID-866/SG is energized when the shared equipment is energized. When used as a remote cut-out as specified in 5.3.5.1.1, the ID-866/SG may be connected to either RED or BLACK primary a.c. power, or to the filtered power source which is connected to its associated send processor.

• (U) 5.2.4 Primary power to other facilities. Primary power for lighting and receptacles in the secure processing center shall be BLACK power and shall not be derived from an electronic equipment power distribution panel. (NOTE: BLACK power may also be BLACK "filtered" power.)

UNCLASSIFIED

UNCLASSIFIED

UNCLASSIFIED

MIL-STD-1680C(SH)
17 March 1993

(U) 5.2.5 RED battery location. A RED common battery power source, if required, shall be located within the secure processing center.

(U) 5.2.6 Approved equipment. Communication, electronic and ancillary equipment installed in a secure processing center shall be of a type included in approved NAVSEA drawings or documents.

* (U) 5.2.7 Cryptographic equipment modification. Modification of cryptographic equipment shall not be made without proper authority. Authorized modifications to a cryptographic equipment are promulgated as changes to the KAM Maintenance Manual for that equipment.

(U) 5.2.8 Cryptographic equipment cables. The cables supplied with cryptographic equipment are often of specific length, wire gauge or shielding characteristics, and are part of the total system design. The fully assembled cables shall not be modified or reduced in length, unless promulgated as an authorized change.

(U) 5.2.8.1 Electronic equipment cables. Some of the interconnecting cables supplied with SPAWAR TEMPEST-approved equipment may be unique in construction and design to enhance its TEMPEST characteristics. Such cables shall not be modified when the installation control drawings or technical manuals specify a prohibition against modification. Typical of cables in this category are the interconnecting cables between the Electrical Service Assemblies (ESA) and the basic teletypewriter unit in low level teletype applications.

(U) 5.2.9 Radio transmitting equipment. Radio transmitters and other devices used for the transmission of electromagnetic energy through space may be installed in or adjacent to a secure processing center. The foregoing allows the transmitter room to be installed adjacent to and to be entered from a secure processing center. In a ship having a RED high level electrical signal distribution system, it is recommended that the electrical perimeter barrier be established between the two spaces to preclude the necessity of applying the TEMPEST criteria (for example, cable type, shielding and bonding) of this standard in the transmitter room. The transmitter room, when so located, is contained within the physical perimeter barrier of the secure processing center.

(U) 5.2.10 Radio set controls. Radio set control units, or other devices providing remote control or indicator circuits (for example, C-1004/SG, C-9351/WSC-3) may be mounted on any RED or

UNCLASSIFIED

MIL-STD-1680C(SH)

17 March 1993

(U) BLACK processing equipment, except as otherwise specified herein (see Appendix A, 50.1.3, and Appendix B, 50.1.5).

- * (U) 5.2.11 Approved cables. Shielded cables shall meet the applicable requirements of MIL-C-17, MIL-C-915, MIL-C-24640, or MIL-C-24643.
- * (U) 5.2.11.1 Cable connecting hardware. Cable connecting hardware, such as stuffing tubes for RED equipment, junction boxes, power panels and terminal boxes within the electrical perimeter barrier of a secure processing center shall be of conductive material in surface ships having a RED high level electrical signal distribution system. This requirement is also applicable to BLACK equipment, junction boxes, power panels and terminal boxes within the electrical perimeter barrier of a secure processing center of a surface ship having a RED high level electrical signal distribution system. Non-conductive cable connecting hardware, such as nylon or plastic, is acceptable for RED or BLACK equipment, junction boxes, terminal boxes and power panels in a ship having a RED low level electrical signal distribution system.
- * (U) 5.2.12 Power panels, junction boxes and terminal boxes. Power panels and cable connecting containers (for example, junction boxes) shall be used to breakout RED cable conductors for splicing, connection or interconnection and shall have a solid surface metal construction. Containers with precut knock-outs shall be avoided; however, they are acceptable if blocked with metallic snap-on buttons, brazed or otherwise secured. When cables are permanently removed from the container, the hole shall be blocked by any of the methods identified herein. This requirement is also applicable to BLACK containers within the electrical perimeter barrier of a secure processing center of a metallic hull surface ship having a RED high level electrical signal distribution system.
- (U) 5.2.13 Cable hangers and supports. Common cable hangers and supports may be used for cable runs if the specified separation requirements are observed.
- * (U) 5.2.14 Bonding methods. Within the electrical perimeter barrier of a secure processing center, for RED equipment and cable, and as specified in other areas, the various parts, units and assemblies of an electrical processing distribution system shall be bonded to ground as specified herein. General bonding requirements for electromagnetic compatibility (EMC) and safety shall comply with MIL-STD-1310 to the extent such requirements do not conflict with the requirements herein. One bonding method

UNCLASSIFIED

MIL-STD-1680C(SH)
17 March 1993

(U) for each equipment may suffice as long as it meets the minimum bonding and grounding requirements of personnel safety, EMC and TEMPEST. In non-metallic hull ships, the third wire or safety ground shall be an acceptable substitute for any bond strap specified herein.

(U) 5.2.14.1 Bonding classes. Bonding methods shall be of the following classes:

- a. Class A. A bond achieved by joining two metallic items or surfaces through the process of welding or brazing.
- * b. Class B. A bond inherent in the installation of an item or equipment by mounting hardware or other areas of metal-to-metal contact.
- c. Class C. A bond achieved by bridging two metallic surfaces with a metallic bond strap.

* (U) 5.2.14.2 Class B bonds. When a class B bond is specified as the method of bonding an equipment, box or panel to ground, all available mounting holes provided in the equipment shall be used. The diameter of the mounting bolts, nuts, and washers shall conform to the mounting holes with normal tolerances. When holes must be drilled, minimum diameter shall be for 0.25-inch hardware unless otherwise specified. Bolts, nuts and washers shall be zinc-plated steel or CRES Series 300. Paint, grease, lacquer, and other resistive materials shall be removed from the surface contact area(s) prior to bonding. Class 3 chemical coatings, i.e. anodizing, applied in accordance with MIL-C-5541 are conductive coatings and shall not be removed. Abrasives used shall be of the type which produce a clean, smooth surface. The cleaned metal surfaces and threaded hardware shall be coated with an antisieze compound conforming to MIL-T-22361 prior to mounting the equipment, except as specified in 5.2.14.17 and 5.2.14.18.

* (U) 5.2.14.3 Flexible bond strap fabrication. Flexible bond strap shall be fabricated from 1-inch flat braided wire, and lugs fabricated from 0.840-inch diameter copper tubing or commercial copper lug with a barrel large enough to accommodate the 1-inch braid without trimming. The length shall be as required and as short as practical. Drill mounting holes for 5/16-inch hardware with normal tolerances. Zinc plating or other protective coating is required on bond straps installed in topside areas and is allowed on bond straps installed in other areas to prolong the effective life of the strap and reduce galvanic action between dissimilar metals. Bolts, nuts, and washers shall be 5/16-inch hardware and zinc plated or CRES Series 300. See inset in

UNCLASSIFIED

MIL-STD-1680C(SH)
17 March 1993

(U) Figure 4 of Appendix I for typical bond strap fabrication. Flexible bond straps will be used to bond resilient mounted equipment or cabinets (see 5.2.14.11) and slide-mounted equipment (see 5.2.14.12).

(U) 5.2.14.4 Solid bond strap fabrication. Solid bond strap material shall be copper, at least 0.020-inch thick, and at least 3/4-inch wide. The length of the bond strap shall be not greater than five times the width and shall be as short as practical. Punch or cut out mounting holes for 5/16-inch hardware with normal tolerances. Zinc plating or other protective coating shall be required on bond straps installed in topside areas and is allowed on bond straps installed in other areas to prolong the effective life of the strap and reduce galvanic action between dissimilar metals. After installation, the bond strap may be painted to match the surrounding area. Bolts, nuts, and washers shall be 5/16-inch hardware and zinc-plated steel or CRES Series 300.

* (U) 5.2.14.5 Preparation for use of bond straps. Bond straps shall be installed in locations which permit rapid inspection and replacement. Bonds shall in no way interfere with internal parts of the equipment or the movement of resilient mounts. Ground studs built into enclosures shall be utilized in preference to drilling a new hole providing the ground stud location on the enclosure will not increase the length of the bond strap beyond normal tolerance. Grease, paint, lacquer, and other resistive materials shall be removed from at least 1-1/2 times the bonding surface contact area. Class 3 chemical coatings, i.e. anodizing, applied in accordance with MIL-C-5541 are conductive coatings and shall not be removed. Abrasives used shall be of the type that produce a clean, smooth surface. The cleaned metallic surface and threaded hardware shall be coated with an antiseize compound, conforming to MIL-T-22361 prior to the installation of the bond strap.

(U) 5.2.14.6 Assembled equipment units. Except where specific equipment bonding requirements are specified herein, assembled equipment (for example, AN/UGC-143 Navy Standard Teletypewriter (NST) Set) shall be considered to have all physical and electrical units properly bonded to each other based on the requirement of the applicable equipment specification. This includes hinged panels, retractable drawer assemblies, and other movable units or parts provided within an assembled equipment for ease of installation or maintenance.

UNCLASSIFIED

MIL-STD-1680C(SH)
17 March 1993

(U) 5.2.14.7 Fabricated equipment units. The main enclosure of fabricated equipment (for example, locally fabricated, engineered or installed console configurations) containing assembled equipment shall be bonded to ground with class A, B, or C bonds. Units shall be bonded to ground via the main enclosure with class A, B, or C bonds, as appropriate.

* (U) 5.2.14.8 Electronic equipment cabinets. Electronic equipment cabinets (for example CY-4516()/S) shall be bonded to ground with class A, B, or C bonds. Conductive Class 3 chemical coatings, i.e., anodizing, applied in accordance with MIL-C-5541 are conductive coatings and shall not be removed. Conductive paint applied in accordance with MIL-P-21035 and conductive caulk should be used when installing equipment racks, cabinets and consoles on their foundations with a Class B bond. Conductive paint applied in accordance with this paragraph shall be certified in writing at the time of application. A copy of this written certification shall be placed in the ship's TEMPEST file. This document shall certify:

- a. that the paint used meets the requirements of Military Specification MIL-P-21035.
- b. that the surface of the conductive material, i.e., metal, etc. to which the paint has been applied has been properly prepared and was completely free of all foreign material prior to application of the conductive paint.
- c. that the paint was properly mixed by volume and applied with sufficient coats to insure conductivity as well as prevent corrosion.
- d. that all attachment hardware fully meets the current requirements of this standard.
- e. that, when tested for resistance between the secondary structure (rack, cabinet or console) and the primary structure (ship's hull), there will be a resistance of no more than 300 milliohms.

* (U) 5.2.14.9 Equipment mounted in electronic equipment cabinets. Equipment, except cryptographic equipment, rack mounted in electronic equipment cabinets may be considered bonded to ground with the front-panel mounting hardware. Surface preparation shall be in accordance with 5.2.14.2 and 5.2.14.5.

UNCLASSIFIED

MIL-STD-1680C(SH)
17 March 1993

(U) 5.2.14.10 Bonding of non-resilient mounted equipment. Non-resilient mounted equipment in their original cabinets, except cryptographic equipment, shall be bonded to ground with a class B bond or class C bond strap. For cryptographic equipment bonding, see 5.2.14.13.

* (U) 5.2.14.11 Bonding of resilient mounted equipment or cabinets. Resilient mounted equipment or cabinets shall be bonded to ground with a class C bond strap. Figures 5 and 6 of Appendix I illustrate typical and specific bonding methods for resilient mounted equipment. Flexible bond straps may be used on equipment having resilient mounts which allow multidirectional excursions that may damage solid class C bond straps. In submarines, the third wire or safety ground shall be an acceptable substitute for a bond strap.

* (U) 5.2.14.12 Bonding of equipment mounted on slide foundations. Equipment mounted on sliding foundations (for example, slide rack-mounted shelves) shall be bonded to the sliding foundations as specified for each category of equipment in 5.2.14.10, 5.2.14.11, and 5.2.14.13. A class B bond may be used to bond the sliding foundation to the solid foundation as specified in 5.2.14.9 if the slide is secured to the rack with hex-head bolts or standard slotted screws. If the slide is secured with fasteners meant to be tightened with fingers rather than tools, the slide foundation shall be class C bonded to the solid foundation by Method A or B as shown in Figure 4, Appendix I. An alternative method to the above is to bond the equipment directly to the solid foundation with a solid or flexible class C bond strap, as appropriate. In submarines, the third wire or safety ground shall be an acceptable substitute for a bond strap.

(U) 5.2.14.13 Bonding of cryptographic equipment. Cryptographic equipment and cryptographic ancillary units (for example, TSEC nomenclature equipment) shall be bonded to ground with a class C bond strap, except as otherwise specified herein. A new hole shall not be drilled in cryptographic equipment or cabinet enclosure, except where the equipment has a separate cable entry section. Existing mounting holes may be enlarged to accommodate standard mounting hardware. The following are typical bonding arrangements for cryptographic equipment:

- a. TSEC/KG-30 Family. Install three mounting bolts with standard flat washers on each bolt between the foundation and the TSEC/KG-30 Family member

UNCLASSIFIED

MIL-STD-1680C(SH)
17 March 1993

- (U) (for example TSEC/KG-35, TSEC/KG-36, and TSEC/KG-38.) Install the fourth mounting bolt with a flat washer and bond strap. The bond strap shall be against the equipment with the flat washer between the bond strap and the foundation. Secure the loose end of the bond strap to the foundation with 5/16-inch hardware. An alternate method is to connect a bond strap between the case of the equipment cable entry section and the foundation. (See Figure 22, Appendix I).
- b. TSEC/KI-1. The designated mount, MT-4580/U or MT-4667/U, provides the necessary bond between the KIT/1(V)/TSEC and a foundation. The designated mount, MT-3950/U, MT-4580/U or MT-4667/U provides the necessary bond between the KIR-1(V)/TSEC and foundation. The designated mounts shall be bonded to ground with a class B bond or a class C bond strap.
 - c. TSEC/KG-40 or KG-40A. The designated mount, MT-4417/S, provides the necessary bond between the TSEC/KG-40 and a foundation. The designated mount shall be bonded to ground with a class C bond strap installed between the ground stud provided on the mount and the foundation.
 - d. TSEC/KG-44. The TSEC/KG-44 mounted in the OL-350/SMQ-11 has an inherent bond to ground and does not require additional bonding. The AN/SMQ-11() shall be bonded to ground with a class C bond strap.
 - * e. TSEC/KG-45. The TSEC/KG-45 mounted in the electronic cabinet containing the OR-209/SRQ-4 has an inherent bond to ground, and does not require additional bonding.
 - f. KGR-28/TSEC. The KGR-28/TSEC mounted in a KGF-28/TSEC mounting panel that is installed as part of the AN/SMQ-10, Meteorological Data Receiver-Recorder Set, has an inherent bond to ground, and does not require additional bonding.
 - * g. KGX-40/TSEC. The KGX-40/TSEC shall be bonded to its mount with a class B bond. The mount shall be bonded to ground with a class B bond or a class C bond strap.

UNCLASSIFIED

MIL-STD-1680C(SH)
17 March 1993

- * (U) h. TSEC/KY-58. The TSEC/KY-58 is bonded to the HYX-58/TSEC via the mechanical fasteners. The HYX-58/TSEC mounted in the MT-4841(V)/U is bonded to that unit with the internal copper fingered leaf springs, and does not require additional bonding.
- * i. TSEC/KY-75. The TSEC/KY-75 shall be bonded to ground with a solid class C bond strap attached to the front panel stud of the TSEC/KY-75 and the MT-4841/U electrical equipment mounting base. An additional flat washer shall be installed to ensure a tight bond.
- * j. MT-4841(V)/U. Units mounted in MT-4841(V)/U (except the TSEC/KY-75 and AN/USC-43 (ANDVT)) have an inherent bond to the MT-4841(V)/U. The MT-4841(V)/U may be class B bonded if the rear mounting flanges are bolted to ground; otherwise, the MT-4841(V)/U shall be bonded to ground with a class C bond strap.
- * k. TSEC/KG-59 and KOK-6/TSEC. The TSEC/KG-59 and KOK-6/TSEC shall be bonded to ground with a class B bond or a class C bond solid strap.
- * l. TSEC/KG-84. The standard TSEC/KG-84 installation using the MT-4841(V)/U Ship Shelf has an inherent class B bond to the MT-4841(V)/U. The non-standard installation without the MT-4841(V)/U shall be class C bonded using the TSEC/KG-84 grounding plate kit.
- * m. TSEC/KGV-11. The TSEC/KGV-11 mounted in the TD-1271B/U, part of the OK-454(V)/WSC-3 or OK-455(V)/WSC, has an inherent bond to the electrical equipment cabinet. The electrical equipment cabinet shall be bonded to ground with a class B bond or a class C solid bond strap.
- * n. TSEC/KWR-46. The TSEC/KWR-46 has an inherent bond to the HNF-1/TSEC through the mounting hardware. The HNF-1/TSEC is bonded to the mounting shelf with a solid class C bond strap.
- * o. TSEC/KYV-5. The TSEC/KYV-5 has an inherent class B bond to the AN/USC-43(V) Basic Terminal Unit (BTU). The BTU shall be bonded to ground with a class C solid bond strap between the ground stud on the BTU and the foundation.

UNCLASSIFIED

MIL-STD-1680C(SH)

17 March 1993

(U) 5.2.14.14 Bonding of isolation devices and filters. Isolation devices and telephone and signal line filters shall be bonded to ground with class B bonds or class C bond straps. Power filters shall be bonded to ground with a class C bond strap.

(U) 5.2.14.15 Bonding of RED terminal boxes and power distribution panels or switch boxes. Terminal boxes, junction boxes, primary a.c. power distribution panels and switch boxes which are part of a RED electrical processing system shall be bonded to ground with a class B bond or class C bond strap.

* (U) 5.2.14.16 Bonding of BLACK terminal boxes and power distribution panels or switch boxes. Terminal boxes, junction boxes, primary a.c. power distribution panels and switch boxes which are part of a BLACK electrical processing system within the electrical perimeter barrier of a secure processing center shall be bonded to ground with a class B bond or class C bond strap. This requirement is only applicable to metallic hull surface ships having a RED high level electrical signal distribution system.

* (U) 5.2.14.17 Bonding of covers to RED terminal boxes and junction boxes. Metal-to-metal contact shall be established around the entire perimeter between the cover and box of terminal and junction boxes which are part of a RED electrical processing system.

* (U) 5.2.14.18 Bonding of covers to BLACK terminal boxes and junction boxes. Metal-to-metal contact shall be established around the entire perimeter between the cover and box of terminal and junction boxes which are part of a BLACK electrical processing system within the electrical perimeter barrier of a secure processing center of metallic hull surface ships having a RED high level electrical signal distribution system.

(U) 5.2.14.19 Bonding of shields and armor on RED cables. RED cables shall have the shields (and armor, if applicable) of the cable bonded to ground at both ends of the cable in accordance with the following:

- a. Cable shields for low level circuits terminating on barrier terminal strips as specified in 5.1.9.1 shall be bonded to ground within the enclosure at the terminal strip.
- b. Cable shields for RED high level signaling circuits shall be bonded to ground at the point of entry to an enclosure.

UNCLASSIFIED

MIL-STD-1680C(SH)

17 March 1993

- (U) c. Cable shields not covered by a. and b. above shall be bonded to ground by any of the following:
- (1) At a terminal strip within an enclosure.
 - (2) At the point of entry within an enclosure.
 - (3) Via a standard threaded cable plug connector which shall provide shield bonding via the connector hardware.
- d. Armor shall be bonded to ground at the point of entry to an enclosure.
- e. RED cables requiring an ungrounded shield at one end of the cable in conformance with manufacturer's specifications shall be approved by NAVSEA (Code 03K222) prior to installation.
- f. The methods of bonding shields and armor shall be in accordance with one or more of the following:
- (1) Figures 7 through 10, Appendix I.
 - (2) Any of the methods of MIL-STD-1310.
 - (3) Any of the methods in DOD-STD-2003 that provide for the bonding of shields or armor.
 - (4) The use of ground ring kits and connectors designed to provide shield bonding via the connector hardware, including coaxial and triaxial.
 - (5) Other methods having prior approval of NAVSEA (Code 03K222) which will be based on submitted drawings or sketches illustrating the methods proposed.

(U) 5.2.14.20 Bonding of shields and armor on BLACK cables. In metallic hull surface ships having a RED high level signal distribution system, BLACK cables with shield or armor, within the electrical perimeter barrier of a secure processing center, shall have the shield(s) (and armor, if applicable) bonded to ground at both ends of the cable in accordance with the following:

- a. Cable shields shall be bonded to ground by any of the following:
- (1) At a terminal strip within an enclosure.
 - (2) At the point of entry within an enclosure.
 - (3) Via a standard threaded cable plug connector which shall provide shield bonding via the connector hardware.

UNCLASSIFIED

MIL-STD-1680C(SH)

17 March 1993

- (U) b. Armor shall be bonded to ground at the point of entry to an enclosure.
- c. Cables requiring an ungrounded shield at one end of the cable in conformance with manufacturer's specifications shall be approved by NAVSEA (Code 03K222) prior to installation.
- d. The methods of bonding shields and armor shall be in accordance with one or more of the following:
 - (1) Figures 7 through 10, Appendix I.
 - (2) Any of the methods of MIL-STD-1310.
 - (3) Any of the methods in DOD-STD-2003 that provide for the bonding of shields or armor.
 - (4) The use of ground ring kits and connectors designed to provide shield bonding via the connector hardware, including coaxial and triaxial.
 - (5) Other methods having prior approval of NAVSEA (Code 03K222) which will be based on submitted drawings or sketches illustrating the methods proposed.

(U) 5.2.14.21 Bonding of cables penetrating a secure processing center. In metallic hull surface ships having a RED high level electrical signal distribution system, shielded or armored cables penetrating the electrical perimeter barrier of a secure processing center shall have the outer-most shield (and armor, if applicable) bonded to ground in accordance with the following:

- a. The outer-most shield (and armor, if applicable) shall be bonded to ground on the inside of the secure processing center at the point where the cable penetrates the electrical perimeter barrier.
- b. The methods of bonding shields and armor shall be in accordance with one or more of the following:
 - (1) Figures 11 through 14 of Appendix I.
 - (2) Any of the methods of MIL-STD-1310.
 - (3) Any of the methods in DOD-STD-2003 that provide for the bonding of shields or armor.
 - (4) The use of ground ring kits and connectors designed to provide shield bonding via the connector hardware, including coaxial and triaxial.
- c. In addition, cable shields shall be bonded to ground as applicable in 5.2.14.19 and 5.2.14.20.

UNCLASSIFIED

MIL-STD-1680C(SH)
17 March 1993

* (U) 5.2.14.22 Bonding of spare and unused cables and conductors. Unused or spare conductors and shields (and armor, if applicable) of RED cables which penetrate the electrical perimeter barrier of a secure processing center shall be bonded to ground at both ends. This requirement does not apply to conductors in Automated Single Audio System cables identified in Note 29 in NAVELEX Drawing 28687-0125013 Rev F. This requirement is also applicable to BLACK cables in a metallic hull surface ship having a RED high level electrical signal distribution system. Unused or spare conductors shall have a length sufficient to be connected to any of the terminations.

(U) 5.2.14.23 Bonding of conduit and metal ducts. Conduit or metal ducts required in 5.1.10.3, 5.1.10.6, 5.1.10.7, 5.1.10.10, 5.1.10.17, and 5.1.10.18 shall be bonded to ground within 3 inches of each exposed end, and at points of electrical perimeter barrier penetration. Conduit shall be bonded to boxes or equipment by welding or by the use of bushing and locknuts. Conduit fitting covers shall be tack-welded to fittings where possible or sealed with a conductive non-corroding sealant if welding is not practical. All cover retaining screws shall be in place. Conduit runs that contain pipe unions shall have the nut (collar) portion tack-welded to the male tail piece after the union has been made up. The methods of bonding are illustrated on Figures 16 and 17 of Appendix I.

* (U) 5.2.14.24 Conduit. Conduit shall be of the thin or thick walled, ferrous or non-ferrous type. Flexible type conduit, where used, shall be of RF-tight construction. Greenfield and similar spiral flexible conduit shall not be acceptable. Publication NAVSEA S9407-AB-HBK-010 is a prime source of data concerning acceptable flexible conduit and related bonding techniques. RF-tight conduit may define the electrical perimeter of a secure processing center and alleviate cable separation requirements.

(U) 5.2.14.25 Bonding of non-processing equipment and devices. Electrical lighting fixtures and other electrical non-processing equipment and devices in a secure processing center need not have bonding applied as a TEMPEST requirement.

UNCLASSIFIED

MIL-STD-1680C(SH)

17 March 1993

(U) 5.2.14.26 Removal of armor. The armor may be stripped from shielded cable as an alternative to bonding the armor to ground.

(U) 5.2.15 Electrical perimeter barrier. That part of the secure processing center that processes RED electrical information shall be enclosed by an electrical perimeter barrier. This requirement is not applicable to non-metallic hull surface ships.

(U) 5.2.15.1 Electrical perimeter barrier doors. Doors, with the exception of emergency exit doors, which form a part of the electrical perimeter barrier of a secure processing center of metallic hull surface ships having a RED high level electrical signal distribution system shall be equipped with a door closer conforming to FF-H-121. Each side of such doors, except normal access doors, shall have a sign stating "DOOR NOT TO BE LEFT OPEN WHILE OPERATING RED PROCESSING EQUIPMENT." Additional normal access door requirements are specified in 5.3.1.2 through 5.3.1.5.

UNCLASSIFIED

MIL-STD-1680C(SH)

17 March 1993

(U) 5.3 Physical security installation standards. The detailed requirements of 5.3.1 through 5.3.6.1 shall accomplish the following:

- a. Physically protect classified information and materials.
- b. Assist in the operational control of equipment.
- c. Prevent inadvertent compromises.
- d. Maintain the cryptographic equipment security level.

* (U) 5.3.1 Security spaces. Spaces or stations having RED processing equipment shall be designated a Secure Processing Center, Secure Remote Area, Remote Area or an Exposed Remote Station, as applicable. These spaces shall meet the physical security requirements of OPNAVINST 5510.1 as implemented herein and commensurate with the classification of the information to be handled. An Exposed Remote Station shall have only secure voice operating positions.

(U) 5.3.1.1 Physical perimeter barrier. The physical perimeter barrier (PPB) of a secure processing center and a secure remote area shall be installed in a manner which will preclude access to, or viewing of, the classified data within the space by unauthorized personnel.

(U) 5.3.1.1.1 Maintenance access panels. The physical perimeter barrier may have a maintenance access panel for the purpose of providing access from outside the space to equipment within the space. If the panel location outside of the physical perimeter barrier is in a passageway or compartment not subject to frequent usage by personnel, the panel shall be secured with a hasp and a combination padlock conforming to FF-P-110, type DE, class 2. Otherwise, the panel shall be secured with studs or bolts and nuts with center to center spacing not to exceed 4 inches.

(U) 5.3.1.2 Normal access. A secure processing center shall have only one normal access. The normal access door shall be plainly identified by a sign which reads "RESTRICTED AREA - NO ADMITTANCE BEYOND THIS POINT" (see OPNAV Form 5510-14).

(U) 5.3.1.3 Normal access door requirements, metallic hull surface ships. The normal access door to a secure processing center in metallic hull surface ships shall be in compliance with the following:

UNCLASSIFIED

MIL-STD-1680C(SH)

17 March 1993

- * (U) a. Metal joiner doors shall be similar to the honeycomb core (Drawing 805-4629248), type H door (Drawing 804-1642434), type A door (Drawing 804-1642752) or type L door (post office) (Drawing 804-1643220). They shall be tight fitting, and constructed in such a manner which will preclude unauthorized removal of and hamper access to hinge pins and anchor bolts, as well as obstruct access to locking bolts between the door and frames. A dutch door shall not be installed.
- b. The door shall be equipped with a door closer conforming to FF-H-121.
- c. The door shall be fitted with a latch, and a manipulation-resistant three-tumbler combination lock, style I, MIL-L-15596. Combination locks shall be equipped with a No. 50 pinch proof deadlock extension. For new construction ships and new installations in active fleet ships, combination locks shall be equipped with a top reading dial.
- d. The door shall be self locking and equipped with a pushbutton electrical or mechanical access control (cipher lock). These access controls are intended for use when the space is manned, at which time the combination mechanism may be disengaged. The access control satisfies the self locking requirement.
- e. The door may be equipped with a facility for personnel identification.
- f. Where the normal access door is in a bulkhead that is part of an air tight perimeter, the air tight integrity may be maintained by collocating the air tight door with the joiner door, or by adding a vestibule. The fittings specified in items a. through e. shall be on the joiner door.

(U) 5.3.1.3.1 Secure remote area doors. Normal access door(s) and emergency exit(s), if used, of a secure remote area shall be of the same structural characteristics as its surrounding bulkhead. There are no limitations to the number of access(es) and exit(s). Dutch doors shall not be installed. Emergency exits shall be operable only from inside the space. Normal access doors shall be equipped as follows:

UNCLASSIFIED

MIL-STD-1680C(SH)
17 March 1993

- * (U) a. With a built-in manipulation-resistant three-tumbler combination lock, Style I, MIL-L-15596, or a Type DC or DE, Class 1 or 2, combination padlock, FF-P-110, and hasp.
- b. A sign on the outer side of the door(s) which reads, "RESTRICTED AREA - NO ADMITTANCE BEYOND THIS POINT".
- c. The door shall be equipped with a door closer conforming to FF-H-121. This requirement is applicable only when the secure remote area is a normally manned space. This requirement does not apply to watertight/airtight doors.
- * d. The door may be self locking and equipped with a pushbutton electrical or mechanical access control (cipher lock). These access controls are intended for use when the space is manned at which time the combination mechanism may be disengaged. The access control satisfies the self locking requirement. This requirement is applicable only when the secure remote area is a normally manned space.

(U) 5.3.1.4 Normal access door requirements, submarines. The normal access door to a secure processing center in a submarine shall be in compliance with the following:

- a. The door shall be one of the following:
 - * (1) Sliding type metal joiner doors shall be similar to type C (Drawing 804-1631627) which are tight fitting and constructed in a manner which will preclude unauthorized removal. The door shall be fitted with a built-in combination lock and locking hardware, and fabricated in accordance with Drawing SSN 637-604-2159329 and SHIPALT 1314.
 - * (2) Swinging type metal joiner doors shall be similar to the honeycomb core (Drawing 804-4629248), type H door (Drawing 804-1642434), or type A door (Drawing 804-1642752), tight fitting, and constructed in a manner which will preclude unauthorized removal of and preferably hamper access to hinge pins and anchor bolts, as well as obstruct access between locking bolts and the frame. The door shall be fitted with a latch and a manipulation-resistant three-tumbler combination lock, style I, MIL-L-15596. Combination locks shall be equipped with a No. 50 pinch proof deadlock extension. For new construction ships

UNCLASSIFIED

MIL-STD-1680C(SH)

17 March 1993

(U) and new installations in active fleet ships, combination locks shall be equipped with a top reading dial. The door shall be equipped with a door closer conforming to FF-H-121. A dutch door shall not be installed.

- b. Equipped to be self locking.
- c. Existing doors shall be installed or modified in accordance with SHIPALT SSBN-207, SSN-938 or SS-966.
- d. A sign on the outer side of the door which reads, "RESTRICTED AREA - NO ADMITTANCE BEYOND THIS POINT".

(U) 5.3.1.5 Normal access door requirements, non-metallic hull ships. The normal access door to a secure processing center in a non-metallic hull ship shall be in compliance with the following:

- a. The door shall be in accordance with Drawing MSC-122-1842876, or constructed of material comparable to that of the surrounding bulkhead.
- b. The door shall be tight fitting and constructed in a manner which will preclude unauthorized removal of and preferably hamper access to hinge pins and anchor bolts, as well as obstruct access to lock bolts between the door and frame.
- c. The door shall be equipped with a door closer conforming to FF-H-121.
- d. The door shall be fitted with a latch, and a manipulation-resistant three-tumbler combination lock, style I, MIL-L-15596. Combination locks shall be equipped with a No. 50 pinch proof deadlock extension. For new construction ships and new installations in active fleet ships, combination locks shall be equipped with a top reading dial.
- e. The door shall be self-locking. It shall be equipped with a pushbutton electrical or mechanical access control (cipher lock). These access controls are intended for use when the secure processing center is manned at which time the combination tumbler mechanism may be disengaged. The access control satisfies the self-locking requirement.
- f. The door may be equipped with a facility for personnel identification.

UNCLASSIFIED

MIL-STD-1680C(SH)
17 March 1993

(U) g. A sign on the outer side of the door which reads,
"RESTRICTED AREA - NO ADMITTANCE BEYOND THIS POINT".

* (U) 5.3.1.6 Emergency exits. Emergency exits shall be operable only from inside the secure processing center or secure remote area. Where doors are used as emergency exits, the door shall be tight fitting and constructed in such a manner which will preclude removal of, and preferably hamper access to, hinge pins and anchor bolts, as well as access to locking bolts between the door and frame. Doors which form a part of the electrical perimeter barrier shall conform to 5.2.15.1. A dutch door shall not be installed as an emergency exit.

(U) 5.3.1.7 Acoustical isolation. Normal speech level within a secure processing center shall not be capable of being monitored outside the physical perimeter barrier of the secure processing center taking into account both physical perimeter barrier construction and normal ambient noise.

(U) 5.3.1.8 Visual barrier. A curtain or other visual barrier shall be installed inside the secure processing center behind the message passing window and the normal access door, where viewing classified information is possible within a radius of 10 feet of the point of visual penetration from outside the space.

* (U) 5.3.1.9 Intrusion alarm. An intrusion alarm system shall be provided for the access(es) and exit(s) serving the physical perimeter barrier of a secure processing center or secure remote area in a surface ship. This system shall provide a means of warning when any access or exit in the space is opened, or when there is a loss of power to the alarm system. The system shall provide the following functions and safeguards:

a. Audible and visual indicators of an alarm shall be provided at the supervisory position within the space.

* b. Alarm signals shall be extended to audible and visual indicators at one or more remote stations capable of responding to an alarm condition. A supervisory feature shall be provided on remote alarm lines.

c. Any access or exit opening, momentary or otherwise, shall hold an alarm condition until disabled at the supervisory position.

d. A disconnect feature within the space shall be connected to permit the cutout of remote alarms when the space is manned.

UNCLASSIFIED

MIL-STD-1680C(SH)
17 March 1993

- (U) e. A variable (for example, 15-60 seconds) time delay function shall be provided and connected to permit the space to be vacated without generating local or remote alarms.
- * f. When the space is manned, the normal access door sensor(s) shall have a disconnect feature. The emergency exit sensor(s) shall be connected to the alarm system at all times and shall not have a disconnect feature installed, except the disconnect features inherent in the IC/SM Alarm Switchboard. A primary power switch shall not be considered an alarm cutout function. Disabling, disconnecting or cutout features of an alarm sensor shall provide, as a minimum, an abnormal visual indication. Note that secure remote areas may have more than one normal access door which may have a disconnect feature installed.
- g. An audible alarm indicator shall be capable of being silenced following any initial energizing of the indicator. Such a silencing feature shall not disable any circuit between the sensor(s) and the visual indicator(s).
- * h. Switches, sensors and primary power shall be located within the space. Door or scuttle sensor switches shall be tamper-resistant in accordance with Drawing 401-1973965, except that the lock wire specified in the drawing is not required.
- * i. A power failure relay shall be connected to the alarm system input power so that an alarm will be initiated at the remote station(s) whenever there is a loss of power and the space is unmanned. The power failure relay contacts shall be connected in parallel with the summary intrusion alarm. The alarm system shall be permanently connected to BLACK power within the secure processing center or secure remote area.
- j. An extended intrusion or power failure alarm to the remote station(s) shall be a separate alarm signal, and not a summary of other alarm signals terminating within the space (for example, the frequency standard alarm).

UNCLASSIFIED

MIL-STD-1680C(SH)
17 March 1993

(U) 5.3.1.10 Message passing scuttles. Message passing scuttles, where installed in surface ships, are subject to the following restrictions (see Drawing 805-2218179):

- a. Passing scuttles shall be constructed and installed so as to prevent unauthorized access into a secure processing center.
- b. Passing scuttles shall be installed in a manner which will prevent viewing of the interior of a secure processing center.
- c. Two-way passing scuttles shall only be installed between spaces which are under the control of communication personnel. One-way passing scuttles may be installed for passing messages to a secure processing center.

(U) 5.3.1.11 Message passing windows. Message passing windows may be installed between a secure processing center and the adjacent area for the purpose of receipt and delivery of message traffic. Message passing windows in surface ships shall be in accordance with Drawing 804-5184152.

* (U) 5.3.1.12 Location of cryptographic and classified information processing equipment. Cryptographic equipment and other classified information processing equipment may be located outside secure processing centers and secure remote areas provided the equipment and classified information is afforded adequate physical security.

* (U) 5.3.1.12.1 Location of cryptographic equipment. Cryptographic equipment should be located in a secure processing center or secure remote area. Cryptographic equipment may be located external to a secure processing center provided they are physically mounted in an approved security container. Specific NAVSEA approval shall be obtained for proposed locations external to a secure processing center. Cryptographic equipment which are commonly located external to a secure processing center along with the associated approved security containers are as follows:

- a. TSEC/KG-40, see the following NAVSEA drawings:

10 D 2562	10 B 2317	10 D 2322
10 B 2313	10 D 2318	10 D 2323
10 D 2314	10 B 2319	10 B 2325
10 C 2315	10 D 2320	10 D 2327
10 D 2316	10 D 2321	10 D 2328

UNCLASSIFIED

MIL-STD-1680C(SH)

17 March 1993

- (U) The secure cover shall be equipped with a combination padlock conforming to FF-P-110, type DE, class 2.
- * b. TSEC/KI-1(), see Drawing 408-2228164 and RE 2698862. The physical security strap shall be equipped with a combination padlock conforming to FF-P-110, type DE, class 2.
 - * c. TSEC/KG-45, the electronic cabinet that contains the OR-209/SRQ-4. The security bar shall be equipped with a combination padlock conforming to FF-P-110, type DE, class 2.
 - d. TSEC/KGV-11: (Mounted on the TD-1271B/U in OK-454(V)/WSC or OK-455(V)/WSC Control Monitor Group) see Bendix Field Engineering Drawings 15151ASY3533258-0501 and 15151ASY3533259-0501 and A & J Manufacturing Co. Drawing 08060-250-1. The locking bar shall be equipped with a combination padlock conforming to FF-P-110, type DE, class 2.
 - * e. TSEC/KG-44 is mounted in a physically secure compartment in the OL-350/SMQ-11 cabinet. The security compartment within the SMQ-11 cabinet in which the KG-44 is installed shall be locked with a combination padlock conforming to FF-P-110, type DE, class 2.
 - * f. TSEC/KGV-8 mounted in the Joint Tactical Information Distribution System (JTIDS) CY-8589/URC-107(V) Electronic Cabinet Assembly (ECA). The two built-in hasps on the right front and rear of the ECA shall be equipped with combination padlocks conforming to FF-P-110, type DE, class 2.

UNCLASSIFIED

MIL-STD-1680C(SH)
17 March 1993

* (U) 5.3.1.12.2 Location of classified information processing equipment. Classified information processing equipment may be located outside a secure processing center or secure remote area when one or more of the following conditions are met:

- a. The media containing classified information, such as disks and magnetic tapes, may be removed from the RED equipment and locked in an approved container identified in OPNAVINST 5510.1. No classified information shall remain resident in an accessible memory or on a hard disk.
- b. The power and/or signal lines to the RED equipment can be secured from a secure processing center or secure remote area when the space is unmanned.
- c. Install a local primary power switch serving the RED equipment which can be locked with a combination padlock conforming to FF-P-110, type DE, class 2, when the space is unmanned.
- d. The RED equipment may be enclosed in an expanded metal cage, a container, or protected by a security strap secured with a combination padlock conforming to FF-P-110, type DE, class 2. If the equipment or subsystem has an electronic or paper hard-copy display and b. above is not met, a visual barrier shall be provided to prevent unauthorized viewing of the classified information being processed.

(U) 5.3.1.13 Cryptographic repair facilities. Shipboard cryptographic repair facilities are not secure processing centers. However, physical security criteria for a secure processing center shall be applied to the cryptographic repair facility.

(U) 5.3.1.14 Physical security of terminal boxes, cable boxes and similar enclosures. Junction, terminal and cable boxes, cable cabinets and similar enclosures containing RED cables shall meet the following minimum physical security criteria where installed in other than a secure processing center, secure remote area or remote area. Cable pull boxes are excluded from these requirements. The box or cabinet shall be constructed such that evidence of forced entry or tampering would be readily apparent. Hinge pins, screws, bolts, or fastening devices as required shall be tack welded, or the cover shall be secured at opposite ends with combination padlocks conforming to FF-P-110, type DE, class 2, so as to prevent removal by other than forcible means.

UNCLASSIFIED

MIL-STD-1680C(SH)
17 March 1993

(U) The box shall be located in such a manner as to be readily accessible for visual inspection.

(U) 5.3.1.15 Paper destruction equipment. If shredding machines are used for the destruction of classified paper in a secure processing center, secure remote area or remote area, they shall meet the requirements of FF-S-1169, wherein the width of shreds shall not exceed 1/32-inch with a plus tolerance of 1/64-inch. When cross cut is required, such as for destruction of paper communication security material, the shredder shall meet the requirements of NACSI-4010, wherein the dimensions of shreds shall not exceed 3/64-inch in width by 1/2-inch in length or 1/35-inch in width by 7/8-inch in length. Proposals for substitute equipment employing incendiary, pulverizing, or pulping methods shall be submitted to NAVSEA (Code 03K222) for approval.

(U) 5.3.1.16 Cable marking. RED high level cable runs serving a RED electrical processing system shall be marked with a 1-inch wide band of red color at the entrance to equipment, junction boxes, space penetrations and other points which constitute a physical discontinuity in the RED cables. Common marking of bundled cables is permitted. Paint or red tape may be used. This requirement is not applicable to submarines.

* (U) 5.3.1.16.1 Cable designators. On surface ships with a RED high level signal distribution system, RED high level cables shall suffix the letter symbol "/Q" to the normal cable designator (for example, R-RY/Q Radio Teletype). Cables designated as RED low level, secure voice and RED CCTV baseband video shall suffix a letter symbol "/L" to the normal cable designator (for example, R-RY/L Radio Teletype, R-RQ/L Secure Voice, R-TC/L CCTV). This requirement is not applicable to ships with a totally low level SEIPS.

(U) 5.3.2 Modification of call signal station, type IC/D. Call signal station, type IC/D installed in accordance with Drawing S6501-73801, within the physical perimeter barrier of a secure processing center shall be modified as follows (see Figure 18, Appendix I).

- a. Mount a relay (NSN 5945-00-893-1366) on the bottom plate of the rotary selector switch, piece 38, using the existing screws.

UNCLASSIFIED

MIL-STD-1680C(SH)
17 March 1993

- (U) b. Disconnect the lead from the howler, piece 40, that is connected to the terminal board assembly, piece 29, and reconnect to terminal number 7 of the relay.
- c. Disconnect the lead from the attenuator, piece 39, that is connected to the terminal board assembly, and piece 29, and reconnect to terminal number 8 of the relay.
- d. Install new leads from terminal numbers 2 and 3 of the relay to the howler terminals on the terminal board assembly.
- e. Install jumper leads from terminal number 2 to terminal number 6 and from terminal number 3 to terminal number 5 of the relay.
- f. Affix a label to the front of IC/D station enclosure with the following information: "MODIFIED IAW MIL-STD-1680".

* (U) 5.3.3 Patch panel identification. When compatible RED and BLACK patch panels are installed, RED patch panels shall be colored red. Patch panels for BLACK electrical distribution systems shall be colored black or gray.

(U) 5.3.3.1 Patch panel physical separation. Patch panels for RED and BLACK electrical distribution systems which are electrically compatible, in that they could provide an operable circuit via crosspatching with standard length (unmodified) patch cords, shall be separated by a minimum of 6 feet on surface ships and 3 feet on submarines.

(U) 5.3.4 RED and BLACK system sharing. RED and BLACK electrical distribution systems may share the same processing equipment when specified in NAVSEA drawings or documents to meet operational requirements. A transfer, patching or switching system used to connect a position alternately to a RED and BLACK system shall:

- a. Have clearly identified controls with a visual status indication at the operating position or equipment terminal.
- b. Be secure against accidental or unauthorized connection of circuit, channel, or position to the non-secure or secure system.
- c. Be impossible to by-pass unintentionally.

UNCLASSIFIED

MIL-STD-1680C(SH)
17 March 1993

- (U) d. For semiautomatic or automatic systems where manual manipulation is not employed, provide fail-safe operation by circuit lock-up or positive diversion to a secure system in the event of equipment malfunction.
- e. Be considered a part of the secure system to which it will be connected and be afforded the same physical security.

(U) 5.3.4.1 RED operating positions. As a security design objective, RED operating positions shall be installed in a secure processing center or secure remote area. RED operating positions may be installed in a remote area, and secure voice operating positions may be installed at an exposed remote station, when specified in NAVSEA drawings and documents. When a remote operating position is connected to a RED electrical distribution system, it becomes part of that system.

(U) 5.3.4.1.1 RED system interconnection. The RED electrical processing system shall be protected against inadvertent breakout of information in a recoverable form in a space that is not manned or secured. A secure processing center and a secure remote area have facilities installed that provide for security features in a manned or unmanned condition. The RED electrical processing system may interconnect between such spaces with no additional security features required. RED electrical processing system extensions from one of these spaces to a remote area or exposed remote station shall comply with one or more of the following:

- a. Via a semiautomatic or automatic system. Such a system shall have a program that can control access to the system output signal lines, and provide fail-safe operation by circuit lockup in the event of equipment malfunction.
- b. To a parallel data input of equipment via a disconnect switch (for example, SA-1816/UYK Rotary Switch) located in the signal source.

UNCLASSIFIED

MIL-STD-1680C(SH)
17 March 1993

- (U) c. To or from a unit of equipment via an SA-734/SG or SA-2371/SG Switch Box located in the secure processing center or secure remote area.
- d. To secure voice equipment as specified in 5.3.5.5.
- * e. To a remote terminal which requires entering a password before classified information can be received.
- * f. The RED line may run directly to a teletypewriter orderwire that is used exclusively for technical control with another ship or station provided the space is adjacent to and under the control of the Communications Center and its personnel.

(U) 5.3.4.2 BLACK transmit operating positions. BLACK transmit teletypewriter operating positions that are located in the secure processing center shall be physically separated from similar RED transmit teletypewriter operating positions. This physical separation shall be accomplished by a physical barrier, the purpose of which is to clearly differentiate the operating positions. In general, adequate spacing, expanded metal screens, railing, or filing cabinets, in conjunction with clear position marking will suffice.

- * (U) 5.3.4.3 Shared teletypewriter circuits. A type SA-734/SG, SA-2371/SG or SA-2626/BR Switch Box shall be installed in the signal line(s) of each teletypewriter or facsimile equipment used alternately in both RED and BLACK electrical signal distribution systems and as specified in 5.1.1 and 5.3.5.1.1 (see Drawing RE 2682997). The switch box shall be located in a secure processing center or secure remote area for shared equipment within that space. When the shared circuit is in a remote area and only one switch box is used for both interface and disconnect, it shall be located in the SPC or SRA. When the interface and disconnect switches are separate, the disconnect switch shall be located in the SPC or SRA, and the interface switch in the remote area with the shared equipment.

- * (U) 5.3.4.3.1 Cautionary signs for shared operating position. Where a shared operating position consists of a single equipment having independent send and receive signal lines, such as AN/UGC-48, requiring dual SA-734/SG or SA-2371/SG Switch Boxes, both switch boxes shall be in the same position. A cautionary sign stating that both switches shall be in the same position (classified or unclassified) at all times shall be posted adjacent to or on either the applicable switches or their associated indicator lights.

UNCLASSIFIED

MIL-STD-1680C(SH)

17 March 1993

(U) 5.3.4.4 Lock-out switch visual indicator. The ID-866/SG Indicator Light provides a visual indication of the setting of the SA-734/SG or SA 2371/SG Switch Box. Where the switch box is used for a sharing of processing equipment, the indicator light shall be co-located with the processing equipment for operator viewing. Where the switch box is used as a RED signal line disconnect, the indicator light shall be co-located with the switch box. Visual indicator lamps for Classified or Unclassified, or Classified or Disconnect shall have the following color jewels installed:

- a. Green jewel: Color to indicate a classified circuit, or a circuit of higher classification.
- b. Red jewel: Color to indicate an unclassified circuit, a circuit of lower classification, or disconnect position.

(U) 5.3.4.5 Remote voice disconnect. A secure voice remote switching apparatus (for example, C-7594()/U, C-7595()/U, C-10315/U, and SA-2112(V)/STQ) or disconnect switch (for example, SA-1539/S) shall be installed within a secure processing center in the signal or control lines of a secure voice remote operating position. Additionally, where receive-only secure voice circuits are extended from one remote area to another remote area or exposed remote station (for example, from within Combat Information Center (CIC) to an area outside of CIC), a disconnect switch (for example, SB-973/SRR) shall be installed in the receive signal line within the primary remote area.

(U) 5.3.4.6 Speaker disconnect switch. Secure voice monitor speakers shall be capable of being locally disconnected from signal lines. The disconnect feature may be located in the local telephone set (for example, TA-970/U) or on the speaker amplifier.

UNCLASSIFIED

MIL-STD-1680C(SH)
17 March 1993

- * (U) 5.3.5 Telephone push-to-operate feature. In surface ships, rotary, pulse or tone dial telephones having a shore-tie capability, installed within the physical perimeter barrier of a secure processing center shall be equipped with a push-to-operate feature. This requirement is not applicable to the TA-866() in the AN/STC-1 or AN/STC-2 Dial Telephone Terminal or other telephone handsets with a push-to-talk feature and buffer amplifier in the receive element such as the STU-III.

- * (U) 5.3.5.1 Telephone sets with intercommunication units. A combination telephone station, such as the TA-997/STC-2 Automatic Telephone Terminal, which permits a calling station to monitor the called station without a positive personal response or a continuing visual or audible indication, should not be installed within a secure processing center. If this unit is used, it shall be modified to provide continual audible and visual indications that it is in use. These indications shall be of a design to be easily seen or heard in the ambient noise and light levels in the space.

UNCLASSIFIED

MIL-STD-1680C(SH)
17 March 1993

(U) 5.4 Temporary installations of RED processing equipment. Type commander approved temporary installations of RED processing equipment shall conform to the minimum TEMPEST-related configuration control and physical security criteria set forth below. A temporary installation shall not exceed 9 months. Prior to or at the end of the 9 month period, the equipment will be removed, or reinstalled in conformance with 5.1, 5.2 and 5.3. The minimum installation criteria is as follows:

- a. The RED and BLACK signal distribution systems shall be electrically interfaced as specified in 5.1.1.
- b. The RED equipment shall be connected to primary power as specified in 5.1.2.1 and 5.1.2.2
- c. Battery for a RED signal distribution system, if required, shall be RED battery.
- d. RED cable shall be shielded. The shield shall be bonded to ground at each end of the cable.
- e. RED high level cable shall be separated from other cable to the maximum extent possible as specified in 5.1.10.12 through 5.1.10.15.
- f. The RED equipment shall be bonded to ground with a class B bond or a class C bond strap.
- g. The location of cryptographic equipment shall be as specified in 5.3.1.12.1.
- h. The location of RED processing equipment shall be as specified in 5.3.1.12.2.

Additional criteria may be imposed as required on a case-by-case basis. An inspection is required by a certified FTA immediately after the installation is completed. The VTI report shall note that the installation is temporary and that the inspection of the temporary installation was conducted as specified herein.

UNCLASSIFIED

MIL-STD-1680C(SH)
17 March 1993

(U) 6. STATUS, INSPECTION AND REPORTS.

(U) 6.1 Ship status. The TEMPEST status of a ship shall be determined by National Policy (NP) Certification as the result of an instrumented TEMPEST survey or designation as an acceptable risk.

(U) 6.1.1 National policy certification. The NP certification of a ship is the determination that CE does not exist outside the hull of the ship. The NP certification of a ship is based upon the results of TEMPEST tests of systems or equipment.

(U) 6.1.2 Acceptable risk. Acceptable risk is the designation applied to indicate that a TEMPEST vulnerability assessment has been made and it has been determined that an instrumented TEMPEST survey is not warranted. Ships are designated in the acceptable risk category when the overall TEMPEST posture for that ship has not been determined by instrumented TEMPEST survey. Operational limitations are imposed by OPNAVINST C5510.93 on ships operating in an acceptable risk category.

* (U) 6.1.3 Acceptable hazard. An acceptable hazard designation is applied to a ship by CNO/COMNISCOM to indicate that although an instrumented TEMPEST survey has determined that CE is present outside the secure processing center, the TEMPEST signal exploitation vulnerability is minimal, and that correction of the TEMPEST problem is not required. An "acceptable hazard" designation applies only so long as the parameters remain constant. Alteration or modification of an equipment or system may lead to cancellation of an "acceptable hazard" designation.

* (U) 6.1.4 Change in ship status. Any addition, deletion or modification to a ship's SEIPS, or to any equipment or system located within the electrical perimeter barrier of a secure processing center shall be immediately followed by an inspection by a certified FTA. When discrepancies are reported, CNO may void any existing National Policy certification or acceptable risk designation and impose operational limitations in addition to those imposed by OPNAVINST C5510.93.

UNCLASSIFIED

MIL-STD-1680C(SH)
17 March 1993

(U) 6.2 Types of inspections.

(U) 6.2.1 Visual TEMPEST configuration control inspection (VTCCI). The VTCCI is composed of two parts. The first part is a visual TEMPEST inspection (VTI) to determine compliance or noncompliance of the system being inspected with the installation criteria contained in this standard. The second part of a VTCCI is plan and elevation diagrams of the information processing system to be used in a configuration control program. A VTCCI is required for all ships which have a SEIPS installed. The initial VTCCI for each ship shall normally be conducted upon completion of the SEIPS installation for new construction, modernization or overhaul where major changes have been made to the SEIPS. Completeness and accuracy of the VTCCI shall be verified at least once during each Engineering Operating Cycle and prior to the conduct of an instrumented TEMPEST survey. The most recent VTCCI report and amendments thereto shall be retained by the ship and shall reflect the existing configuration and all installation discrepancies that may exist. The VTCCI may be amended as specified in 3.2 and 6.2.2.

(U) 6.2.1.1 Visual TEMPEST inspection. A VTI is conducted as part of a VTCCI. Report of noncompliance with the applicable paragraphs of this installation criteria shall include sufficient detail to permit reviewing activities to determine if a potential security hazard exists and to initiate appropriate action, as required.

* (U) 6.2.1.2 Configuration control plan and elevation view diagrams. The configuration control plan and elevation view diagrams shall identify by equipment type and relative location all equipment of the SEIPS installed within the electrical perimeter barrier (EPB) of the secure processing center(s) (SPC) and shall include relative location and electrical configuration of all RED signal and power transfer panels, BLACK teletypewriter signal and power transfer panels. (BLACK power transfer panel drawings are required only for ships with a RED high level signal distribution system). Equipment in the SEIPS, except signal and power transfer panels and switching units, that are installed outside the SPC need only be identified in the VTCCI by equipment type and space location.

* (U) 6.2.2 Partial TEMPEST inspection. A partial TEMPEST inspection is conducted to verify that previously reported, installation discrepancies have been properly corrected or to update the initial VTCCI documentation to include an approved addition, deletion or modification to the SEIPS. System changes, where applicable, shall be reflected in revised configuration

UNCLASSIFIED

MIL-STD-1680C(SH)
17 March 1993

(U) control plan and elevation view diagrams that are submitted as an enclosure to partial TEMPEST inspection reports. A partial TEMPEST Inspection report amends and shall reference the most recent complete system VTCCI by letter originator, serial number and date.

- * (U) 6.2.3 Ship single secure electrical information processing system. A ship has only one SEIPS regardless of space or functional distinctions. An NP certification or acceptable risk category designation applies to the total ship system. (see 3.2, 6.2.2)

(U) 6.3 Inspections required. All ships with an installed SEIPS shall be inspected as specified herein and shall maintain a visual TEMPEST inspection file that will include the most recent VTCCI report and amendments thereto and, if applicable, instrumented TEMPEST test results for tests completed after the most recent VTCCI.

- * (U) 6.3.1 Inspection of work by installation activity. Installation activities (for example, Naval Shipyards, Supervisor of Shipbuilding, Conversion and Repair (SUPSHIP), Naval Electronic Systems Engineering Center (NAVELEXCEN) installation teams, and others) are responsible for inspecting and reporting, by a certified FTA, the final condition of an installation. For minor additions, deletions or modifications, only the subsystem which has been installed, altered or modified need be inspected; however, any discrepancies observed by the inspector shall be reported. A complete system VTCCI shall be conducted for all ships completing new construction or modernization and when major alterations to the SEIPS are installed. The VTCCI inspections are part of the installation and chargeable to the same contract, project order or ship alteration. The installing activity is responsible for correction of all discrepancies attributable to installation. The report of a partial inspection shall be an amendment to the initial complete VTCCI inspection report and shall include an amendment to the plan and elevation drawings.

- * (U) 6.3.2 Inspection of work by ship force. The Commanding Officer of a ship is responsible for acquiring an FTA inspection when alterations or modifications are performed to the existing configuration of the SEIPS by own ship force or by any other forces afloat (for example, tenders, repair ships and shore intermediate maintenance activities). This should normally be arranged concurrent with the request to, and approval from, the Type Commander which is required for any alteration or modification to the existing configuration of the SEIPS. The inspection report shall include amendments to the most recent

UNCLASSIFIED

MIL-STD-1680C(SH)
17 March 1993

(U) complete system VTCCI report including SEIPS configuration plan and elevation drawings. Only a subsystem which has been installed, altered or modified need be inspected. Any discrepancies, however, observed by the inspector during the inspection shall be reported. In the inspection report, the FTA visual TEMPEST inspector should specifically identify those discrepancies which would normally require the assistance of an industrial activity. The initiation of action to correct discrepancies noted is the responsibility of the Commanding Officer of the inspected ship, and should be accomplished by ship force or referral of the problem to the Type Commander. It will be the responsibility of the Commanding Officer of the inspected ship to request the services of an FTA visual TEMPEST inspector to verify that discrepancies have been properly corrected and have an amending report submitted by the FTA inspection activity.

- * (U) 6.3.3 Delayed inspections. Alterations or modifications to the SEIPS for which a VTCCI cannot be expeditiously acquired shall be reported by message to:

Action: Type Commander
Info: Commander, Naval Sea Systems Command (Code 03K222)
Commander, Naval Investigative Service Command
(Code 26T)

The reporting message shall contain the following as a minimum:

- a. Modification or alteration performed.
- b. Reason for inspection delay.
- c. Planned action or request for assistance.

(U) 6.4 Briefing of ship representative. Upon arrival for an inspection, the FTA will brief the cognizant officers and petty officers of the ship being inspected on the purpose of the inspection, the general conduct of the inspection, and of any assistance required. Upon completion of the inspection, the FTA will inform the cognizant personnel of the general nature of any discrepancies.

- * (U) 6.5 Reports of visual inspections. The narrative inspection report shall reflect compliance or non-compliance with this standard in sufficient detail to permit realistic appraisal without further inquiry. Further, plan and elevation view diagrams will establish a baseline configuration for the SEIPS and shall be used as a future inspection item to identify unauthorized changes to the system. The inspection report shall

UNCLASSIFIED

MIL-STD-1680C(SH)
17 March 1993

(U) identify the FTA inspector by name, FTA card number and FTA card expiration date. The report of a VTCCI shall include a proposed letter to be completed by the ship concerned to either verify the accuracy of plan and elevation diagrams or to report dissimilarities. Inspection reports shall be in the format provided in Appendix G. The inspection report shall be submitted within 90 calendar days after completing the inspection.

(U) 6.5.1 Required information. Inspection reports shall, as a minimum, provide the following information:

- a. Identification of the entire SEIPS or specific subsystem or system inspected.
- b. The method of signaling level employed in each inspected subsystem:
 - (1) Low level or high level for teletype systems.
 - (2) Serial or parallel and fast or slow for digital data subsystems.
 - (3) Identity of each RED fiber optic system.
- c. Specific space identification for inspected secure processing centers, secure remote areas, remote areas, exposed remote areas, special intelligence spaces, secure video control spaces and secure video viewing spaces.
- d. Each reported discrepancy shall be assigned a discrepancy number. The numbers shall be assigned consecutively throughout the ship and shall indicate the total number of discrepancies on the ship.
- e. Each installation discrepancy shall be keyed to the applicable paragraph in this standard and shall be in adequate detail including the system, subsystem, equipment, cable, bond, space, quantity, or any other data to reflect the gravity of the discrepancy.
- f. The assigned priority for the correction of each installation discrepancy. These priorities are indicated by legend under each installation requirement in the inspection check-off sheets in Appendix F. Where the priority assigned is for case-by-case assessment, the report shall provide a detailed description of the discrepancy for an assessment, including any peripheral information which may have an impact on the true representation of the problem.

UNCLASSIFIED

MIL-STD-1680C(SH)
17 March 1993

- (U) g. An assessment as to whether the correction of the reported discrepancies is within the capability of ship force, or would require the assistance of an industrial activity.
- h. Identification of specific physical security deficiencies of spaces containing any part of a secure electrical information processing system.

(U) 6.5.2 Distribution. Inspection reports shall be distributed as follows:

Commanding Officer of ship inspected (Original)
Fleet Commander in Chief
COMSC (For MSC Ships)
Type Commander (COMSCPAC/LANT for MSC Ships)
Commander, Naval Sea Systems Command (Code 03K222)
Commander, Naval Investigative Service Command (Code 26T)
(when inspection report includes special intelligence spaces)
* Director, Office of Naval Intelligence (Code 52)
(when inspection report includes special intelligence spaces which process sensitive compartmented information (SCI))
Intermediate Unit Commander (ship to provide specific addresses if applicable)

(U) 6.5.3 Classification. Inspection reports that document compliance with this standard shall be unclassified. Reports which detail discrepancies in operational ships and link the specific discrepancy to the ship's name or hull number shall be classified CONFIDENTIAL with downgrading instructions in accordance with NSA/CSSM-123-2. If, in the opinion of the FTA inspection activity, the report includes discrepancies of significant magnitude to justify a higher security classification, the report shall be classified SECRET. Such discrepancies might include, but not be limited to, unauthorized modifications to cryptographic equipment or unauthorized electrical connections between RED and BLACK electrical distribution systems. Reports classified SECRET shall identify the discrepancy(ies) that constitute the necessity for assigning a higher security classification. Inspection reports generated by installation or overhaul activities, such as pre-arrival or in-progress reports which are pertinent to the prevention or correction of discrepancies in a SEIPS, shall be classified according to content if the report identifies discrepancies which are likely to exist in the completed installation or overhauled system. These inspection reports or excerpts from those

UNCLASSIFIED

MIL-STD-1680C(SH)
17 March 1993

(U) inspection reports may be unclassified in instructions to design or installation personnel providing the discrepancies identified in the unclassified instructions will be corrected prior to completion of the installation or overhaul.

- * (U) 6.6 Inspection records. Commander, (03K222), Naval Sea Systems Command, 2531 Jefferson Davis Highway, Arlington, VA 22242-5160 will serve as a central depository for inspection reports and will, upon request, provide copies of such reports for use during later inspections or surveys. The VTCCI inspection reports and amendments thereto will be retained in this depository until they are canceled by a more recent VTCCI report.

Preparing Activity:
Navy -SH
(Project 5810-N103)

UNCLASSIFIED

MIL-STD-1680C(SH)
17 March 1993

APPENDIX A SPECIAL INTELLIGENCE SPACE INSTALLATIONS

(U) 10. SCOPE

- * (U) 10.1 Scope. This appendix covers supplementary installation criteria for special intelligence (SI) spaces (for example, Ship Signal Exploitation Space (SSES), Special Security Office, or other areas as specified by NAVSEA). This appendix also specifies the TEMPEST-related configuration control and physical security standards applicable to Passive Information Collection Systems (PICS). SSES, OUTBOARD, Combat Direction Finding (CDF) and other special intelligence spaces shall be designated a secure processing center if classified information processing (CLIPS) equipment is installed in the space; however, extensions of an SI circuit, with the exception of 12MC, shall only be to another SI space. When CLIPS are installed in an SI space, the requirements of 5.1, 5.2, 5.3 and this appendix shall be applied. When CLIPS are not installed in an SI space, the requirements of 5.3 and 50.2 of this appendix shall be applied. This appendix is a mandatory part of the standard. The information contained herein is intended for compliance.

(U) 20. APPLICABLE DOCUMENTS

(U) 20.1 Issues of documents. The following documents of the issue in effect on date of invitation for bids or request for proposals, form a part of this appendix to the extent specified herein.

SPECIFICATIONS

FEDERAL

- AA-F-358 - Filing Cabinet, Steel, Legal and Letter size, Uninsulated, Security.
DIAM 50-3 - Physical Security Standards for Sensitive Compartmented Information Facilities.

UNCLASSIFIED

MIL-STD-1680C(SH)
17 March 1993

APPENDIX A SPECIAL INTELLIGENCE SPACE INSTALLATIONS

(U) DRAWINGS

NAVAL SEA SYSTEMS COMMAND NAVSHIPS

- 804-5184141 - Door, Vault Type for Special intelligence Spaces.
- 805-2217403 - Door, Vault Type Shipboard.
- 815-1853315 - Communications for Secure Spaces 12MC.

(U) (Copies of this specification and drawings required by contractors in connection with specific acquisition functions should be obtained from the contracting activity or as directed by the contracting officer.)

(U) 30. DEFINITIONS

(U) 30.1 Contingency SI space. An area accredited for the physical processing and storing of SI information within a clearly defined physical perimeter barrier on a contingency or part-time basis (averaging not more than 40 hours a month).

(U) 30.2 Passive Information Collection System (PICS). A signal intelligence or signal security system which is a receive-only system processing any level of classified data up to and including Sensitive Compartmented Information.

(U) 30.3 Sensitive Compartmented Information (SCI). Information and materials bearing special controls indicating restricted handling with present and future community intelligence collection programs and their end products for which community systems of compartmentation have been or will be formally established.

(U) 30.4 Short term SI space. An area approved for the physical processing and storage of SI information within a clearly defined physical perimeter barrier for a short term deployment, not exceeding 9 months. This approval is based on the space being manned 24 hours a day when there is cryptographic or SI material within the space, and that prior to or at the end of the 9 month period, the SI space shall be disestablished. The space may contain one or more RED electrical processing equipment requiring an electrical perimeter barrier.

UNCLASSIFIED

MIL-STD-1680C(SH)
17 March 1993

APPENDIX A SPECIAL INTELLIGENCE SPACE INSTALLATIONS

(U) 30.5 Signal Intelligence (SIGINT). A category of intelligence information comprising all communications intelligence, electronics intelligence, and telemetry intelligence.

(U) 30.6 Signal Security (SIGSEC). A generic term which includes both communications security and electronic security.

* (U) 30.7 Special intelligence space. An area approved for the physical processing and storing SI information within a clearly defined physical perimeter barrier requiring full-time physical security safeguards. The area may contain one or more RED electrical processing equipment requiring an electrical perimeter barrier. The SSES and Special Security Office are SI spaces. The Storage and Retrieval Room, Electronic Data Processing Room and the SI Screening Room may be SI spaces. For a listing of which spaces on a particular ship are accredited for SI, refer to the NIPS-1 publication for that ship.

(U) 40. GENERAL REQUIREMENTS.

(U) 40.1 Purpose and coverage. Unless otherwise specified in the detailed requirements, the criteria of this appendix shall be applied to Naval ships as specified herein. An SI space installation in non-metallic hull or super structure shall require specific assessment and approval of NAVSEA (Code 03K222).

(U) 50. DETAILED REQUIREMENTS

(U) 50.1 General. The detailed requirements of TEMPEST-related installation criteria (see 50.1.1), and physical security installation criteria (see 50.2) are separately grouped.

(U) 50.1.1 TEMPEST status. The following establishes the TEMPEST-related configuration control status for the various subsystems processing SI information:

- a. RED Processing equipment, except PICS and teletypewriter equipment, should be SPAWAR TEMPEST-approved.
- b. Teletypewriter equipment of a RED processing system shall be listed in paragraph 50.1, 50.2 or 50.3 of Appendix D.

UNCLASSIFIED

MIL-STD-1680C(SH)
17 March 1993

APPENDIX A SPECIAL INTELLIGENCE SPACE INSTALLATIONS

- * (U) c. An SI teletypewriter circuit between an SI space and a remote terminal in another SI space shall be operated with RED low level signaling.
- * d. Equipment serving as a RED/BLACK signal interface, except for PICS equipment, shall be a SPAWAR TEMPEST-approved device as specified in 5.1.1.
- * e. The PICS equipment should be a SPAWAR TEMPEST-approved isolation device. The RED/BLACK signal interface boundary in PICS equipment is defined as any of the following: (see Figure 19, Appendix I).
 - * (1) The Radio Frequency (RF) input to a system radio receiver: the antenna or antenna coupler is BLACK; the radio receiver is RED.
 - * (2) The antenna control input or output of a receiving or processing unit which processes RED information: the antenna components are BLACK; the unit receiver or processor is RED.
 - * (3) The navigational data input of a receiving or processing unit which processes RED information: the navigational data system (for example, gyro information, latitude and longitude data) is BLACK; the unit receiver or processor is RED.
 - * (4) A unit containing multiple constant level amplifiers: The inputs to the constant level amplifiers may be audio outputs of RED or BLACK, or both, radio receivers or systems; the amplifier outputs shall be connected to the RED audio system.
 - * (5) A general purpose patch (or switch) facility: The BLACK interconnections are limited to RF trunk lines, receiver IF outputs, and time code generators; the RED interconnections are limited to the time code generator, and the specific timing information track of tape recorders.
 - * (6) A time code generator which provides timing to PICS: The input to the generator shall be from a ships frequency standard distribution amplifier (BLACK). The outputs of the generator may be connected to inputs of either RED or BLACK equipment and systems.

UNCLASSIFIED

MIL-STD-1680C(SH)
17 March 1993

APPENDIX A SPECIAL INTELLIGENCE SPACE INSTALLATIONS

(U) 50.1.2 Primary power to PICS. Primary power to PICS equipment shall be:

- a. BLACK to all components if the PICS is SPAWAR TEMPEST-approved.
- b. BLACK to components on the BLACK side of the RED/BLACK boundary.
- c. RED to components on the RED side of the RED/BLACK boundary if the PICS is not listed in Appendix D; 50.1, 50.2 or 50.3.

(U) 50.1.3 Equipment separation. RED PICS equipment shall be separated from BLACK processing equipment as follows:

- a. The SPAWAR TEMPEST-approved equipment shall be located a minimum of 1 foot from BLACK signal processors such as radio transmitters, transmit modems, radio telephones, radio control sets, and transfer switchboards that provide an input to radio transmitters.
- b. The PICS equipment that is not SPAWAR TEMPEST-approved shall not be located in the same cabinet with antenna couplers, and shall be located a minimum of 3 feet from BLACK signal processors identified in a. above.

(U) 50.1.4 Cables. For cable separation, PICS cables on the RED side of the RED/BLACK boundary are to be considered as RED high level cables unless specifically identified as exclusively containing signaling that is in compliance with a RED low level electrical signal distribution system (see 3.44).

* (U) 50.1.5 Non-SI voice operation. Voice operating positions shall be in compliance with the TEMPEST and physical security requirements of the following:

- a. BLACK only transmit radiophone and underwater telephone signal lines from the radiophone or telephone control unit shall be at ground potential when not in an energized condition. The grounding feature shall occur at the electrical perimeter barrier within the space, and shall not ground the signal lines from the radio or underwater telephone equipment.

UNCLASSIFIED

MIL-STD-1680C(SH)
17 March 1993

APPENDIX A SPECIAL INTELLIGENCE SPACE INSTALLATIONS

- (U) b. Whenever a radiophone is used (when connected for other than SI), or underwater telephone transmit capability is used, the control lines shall be equipped to provide the following:
- (1) A warning indicator light at each operating position with a sign on the indicator panel that reads: "NON-SI RADIO IN USE".
 - (2) A flashing electrical warning indicator sign visible to supervisory personnel; the sign shall read: "NON-SI RADIO IN USE".
- c. Radiophones not accredited for SI operation shall not be connected to the SI switching matrix.

(U) 50.2 Physical security.

(U) 50.2.1 Physical perimeter barrier. The physical perimeter barrier of an SI space shall be constructed or fabricated, or both, of aluminum or steel plate with a thickness not less than 0.125-inch. Non-operable elements of the physical perimeter barrier shall be fully braced and welded in place.

- * (U) 50.2.1.1 Restriction on damage control fittings and cables. Because of the security restrictions imposed in gaining access to these spaces, no essential damage control fittings or cables shall be located within or pass through an SI space. This requirement is not applicable to damage control fittings, such as smoke dampers, that may be operated by personnel within the space during normal manning.

(U) 50.2.1.2 Removable hatches and deck plates. Hatches and deck plates less than 10 square feet which are secured by exposed nuts and bolts (external to the SI space) shall be secured with externally attached, high security padlocks. The padlock keys shall be stowed in a security container conforming to AA-F-358. This requirement is not applicable to submarines.

(U) 50.2.1.3 Vent and duct barriers. Vents, ducts, louvers, or other physical perimeter barrier openings with a cross-sectional dimension greater than 96 square inches shall be protected at the perimeter with a fixed man-proof barrier or security grille. The grille shall be fabricated of steel or aluminum grating or bars with a thickness in consonance with the physical perimeter barrier (see 50.1, 50.2.1). If a grating is used, bridge center-to-center measurements shall not exceed 1.42 inches by 4 inches.

UNCLASSIFIED

MIL-STD-1680C(SH)
17 March 1993

APPENDIX A SPECIAL INTELLIGENCE SPACE INSTALLATIONS

(U) Bars shall be mounted on 6-inch centers. The grating or bars shall be welded into place. This requirement is not applicable to through-ducts that have no opening into the space and to submarines.

- * (U) 50.2.2 Normal access door. The normal access door shall be in accordance with Drawing 805-4629248 Metal Joiner Door with honeycomb core. The door shall have a manipulation resistant three tumbler combination lock, style II, MIL-L-15596, equipped with a top reading dial, internal manual escape mechanism and dial dust cover. The requirements of paragraphs 5.3.1.3.b., d., and e. shall apply to the metal joiner door. In addition, a full length astragal shall be installed on the metal joiner door or frame as appropriate. Where the normal access door, either vault type or metal joiner, is in a bulkhead that is part of an air tight perimeter, the air tight integrity may be maintained by collocating the air tight door with the vault or metal joiner door, or by adding a vestibule. This requirement is not applicable to submarines where the normal access door is as specified in 5.3.1.4.

(U) 50.2.2.1 Contiguous SI spaces. Where several SI spaces are contiguous to each other or non-SI spaces in one complex, the entire complex may be enclosed by a single physical perimeter barrier conforming to 50.1 and 50.2.1. Access to the complex shall be from a single normal access door conforming to 50.2.2; each compartment within the complex may have a separate access door from within the common physical perimeter barrier which need not be in conformance with 50.2.2. As an alternative to the above, each SI space may have its own physical perimeter barrier and normal access door conforming to 50.2.2. Access from such an SI space to a contiguous SI space may be via a door not in conformance with 50.2.2; however, access from such an SI space to a contiguous non-SI space shall not be installed.

(U) 50.2.3 Emergency exit. For surface ships, the emergency exit shall be fabricated of steel or aluminum plate in consonance with the physical perimeter barrier as specified in 50.1, 50.2.1 and mounted in a frame braced and welded in place in a manner commensurate with the structural characteristics of the bulkhead, deck or overhead in which it is situated. For surface ships and submarines, the emergency exit shall be operable only from inside the space.

UNCLASSIFIED

MIL-STD-1680C(SH)
17 March 1993

APPENDIX A SPECIAL INTELLIGENCE SPACE INSTALLATIONS

(U) 50.2.4 Acoustical isolation. Perimeter openings, other than the door, shall be sealed with non-hardening caulking material. Normal speech level within the space shall not be capable of being monitored in adjacent areas, including by way of air handling ducts in adjacent spaces, by unauthorized personnel taking into account the normal ambient noise. Additional perimeter acoustical isolation or masking equipment (for example, music sound system), if required, shall be installed within the space.

* (U) 50.2.5 Visual isolation. Doors, or other openings in the physical perimeter barrier through which classified information may be viewed shall be screened or curtained. This requirement is not applicable to submarines where the visual barrier is in accordance with 5.3.1.8.

(U) 50.2.6 Security alarm system. The intrusion alarm (see 5.3.1.9) specified for a secure processing center, shall be provided for an SI space. Additionally, primary power for the alarm shall be connected to an emergency lighting panel within the space.

(U) 50.2.7 Passing scuttles. Passing scuttles shall not be installed between an SI space and any other space on the ship.

(U) 50.2.8 Passing windows. Passing windows shall not be installed between an SI space and any other space on the ship.

(U) 50.2.9 Location of cryptographic equipment. On-line and off-line cryptographic equipment and terminal equipment processing SI information shall be located within an SI space.

* (U) 50.2.10 Special intelligence cables. A cable containing SI information shall conform to the following:

- a. Where the cable is installed external to an SI space, or restricted area, it shall be visually inspectable throughout its length. If the cable passes through normally-locked areas (such as voids, storerooms, and staterooms), or is otherwise uninspectable, it shall be contained in conduit.
- b. Splicing the cable outside the SI space shall be avoided wherever possible by using a continuous cable run. If a splice is required, a junction box shall be

UNCLASSIFIED

MIL-STD-1680C(SH)
17 March 1993

APPENDIX A SPECIAL INTELLIGENCE SPACE INSTALLATIONS

(U) required. The junction box shall be located with adequate spacing between the box and any other object to allow visual inspection of all surfaces, and the cover tack welded, or the cover shall be secured at opposite ends with combination padlocks conforming to FF-P-110, type DE, Class 2, so that an overt attempt to penetrate the box will be obvious. (Junction boxes installed within the SI space shall be accessible for maintenance or system growth and shall not be tack welded.)

c. The cable shall not otherwise break out (for example, to a patch-board or terminal board) at any point along the entire run except in an area accredited that level of security.

d. The cable shall contain only SI circuits.

This requirement is not applicable to submarines or surface ships using the LS-653/UYQ-21 or LS-654/UYQ-21(V) as a replacement for the 12MC.

(U) 50.2.11 Secure storage containers. Secure storage containers conforming to AA-F-358 shall be provided for material and documents. Special intelligence security storage containers shall be welded in place, or otherwise secured to a foundation for safety and to prevent rapid removal. For submarines, a designated storage space for equipment and bulk documents not stowed in the special intelligence security containers shall be equipped with a tamper-proof hasp and combination padlock conforming to FF-P-110, type DE, class 2.

* (U) 50.2.12 Isolation of classified information processing systems. The classified information processing system in SI spaces shall not interconnect to classified information processing systems external to the space except under one or more of the following conditions:

- a. In SI intercommunication announcing systems, as specified in 50.2.15.
- b. In SI sound powered telephone systems, as specified in 50.2.14.1.
- c. To another SI accredited space except for circuits covered by a. and b. above.

UNCLASSIFIED

MIL-STD-1680C(SH)
17 March 1993

APPENDIX A SPECIAL INTELLIGENCE SPACE INSTALLATIONS

- (U) d. Via a disconnect function (for example, switch matrix, disconnect switch, sanitizing switch).
- e. In a parallel data circuit wherein the signal line flow of data is from a non-SI area to the SI space (excluding control lines of the circuit that flow in a reverse direction).

* (U) 50.2.13 Telephones. All telephones, except the TA-866() of AN/STC-1 or AN/STC-2 and the STU-III, shall be provided approved and verifiable on-hook audio security. There are two acceptable methods authorized for providing this security. Neither approach is regarded as being better than the other:

- a. Use of a Telephone Security Group (TSG) type-accepted or type-approved telephone that possess security properties which are intrinsic to the telephone itself. Any TSG type-accepted or type-approved telephone listed in DIAM-50-3 (or its successor document) can be used within an SI space without additional isolation or disconnect measures. Some TSG type-approved telephones may require ringer isolation.
- b. Isolation of telephones from uncontrolled lines. Line isolation may be achieved by the use of either TSG approved disconnect devices or a computerized telephone system (CTS) installed in accordance with TSG guidance. TSG approved isolators, disconnects and CTS installation guidance can be found in DIAM 50-3 (or its successor document).

(U) 50.2.14 Sound powered telephones. Sound powered telephones shall be equipped with a positive disconnect device (such as a plug or jack). Call signal station, type IC/D, when used for circuit EM shall be modified as specified in 5.3.2.

(U) 50.2.14.1 Special intelligence sound powered telephone system. A sound powered telephone system used to process SI information, where installed, shall be in compliance with the following:

- a. The telephone cable shall not break out to jackboxes, switchboards or to telephone sets other than at the designated stations. The telephone cable shall not be

UNCLASSIFIED

MIL-STD-1680C(SH)
17 March 1993

APPENDIX A SPECIAL INTELLIGENCE SPACE INSTALLATIONS

- (U) shared with any circuit other than call or signal systems associated with this circuit.
- b. Be equipped with the selector switch, located at the controlling station capable of:
 - (1) disconnecting all stations,
 - (2) selecting any one station and disconnecting the remaining stations,
 - (3) a parallel connection to all stations.
- c. Other stations that are accredited as an SI space not equipped with the selector switch in item b. shall have a positive disconnect device in the telephone line.
- d. Sound powered telephone sets co-located in a space with this system, and not used for passing SI information, shall have a sign posted that these telephone sets are not for passing classified information.
- e. A call or signal system should be provided. Call signal station, type IC/D, when used for circuit EM shall be modified as specified in 5.3.2.

* (U) 50.2.15 Special intelligence intercommunication announcing system. An intercommunication type announcing system processing SI information which connects to or passes through areas outside the SI space shall use the 12MC system and be installed in accordance with Drawing 815-1853315. The switch matrix panel shall be located within one of the SI spaces. Cables serving this system shall be treated as SI cables (see 50.2.10) and shall be marked with an "/L" designator on ships with a red high level signal distribution system. Primary a.c. power shall be provided from a vital or emergency lighting circuit.

(U) 50.2.15.1 LS-653 or LS-654()/UYQ-21 in lieu of 12MC. The LS-653 or LS-654/UYQ-21(V) with the ON-201/UYQ-21(V) is approved for use as a replacement for the 12MC in ships with a single SI space. The ON-201/UYQ-21(V) may be installed in a general service space which is designated a secure remote area. The SI cable criteria is not applicable to cables between the LS-653 or LS-654()/UYQ-21 and the ON-201/UYQ-21(V).

(U) 50.2.15.2 Supporting intercommunication announcing systems. Intercommunication type announcing systems installed within an SI space which do not process classified information shall be

UNCLASSIFIED

MIL-STD-1680C(SH)
17 March 1993

APPENDIX A SPECIAL INTELLIGENCE SPACE INSTALLATIONS

(U) designed or modified to provide the following physical or electrical security safeguards:

- a. Operational mode of the unit installed within the SI space shall limit operations to push-to-talk mode only.
- b. Receive elements shall be equipped with a local amplifier as a buffer to prevent loudspeakers or earphones from functioning as microphones.
- c. Except as specified in 50.1.5, radio transmission capability for plain language radio telephone (excluding secure voice) shall not be connected. Cable conductors assigned to the transmission of plain language radio telephones shall be connected to ground at each end of the cable.
- * d. Modified equipment shall have a tag affixed to the front or top, as appropriate, stating, "MODIFIED IN ACCORDANCE WITH MIL-STD-1680()". Additionally, the unit shall have a warning sign posted on it stating, "NOT FOR PASSING CLASSIFIED INFORMATION".

* (U) 50.2.16 Commercial intercommunication equipment. Commercial intercommunication equipment that is not included in NAVSEA approved drawings shall not be installed in an SI space.

(U) 50.2.17 General announcing systems. General announcing system loudspeakers shall have an audio amplifier in the signal line to the loudspeaker to serve as a buffer. The amplifier and the output signal lines shall be installed within the SI space.

(U) 50.2.18 Pneumatic tube systems. Pneumatic tube systems for passing SI information shall not be installed. Pneumatic tube systems previously installed shall have the following characteristics:

- a. Locked cover at both ends.
- b. Capability to maintain the pressure or vacuum and lock it in the secure position at the initiating end.
- c. Direct voice intercommunication link between both ends (for example, telephone).

UNCLASSIFIED

MIL-STD-1680C(SH)
17 March 1993

APPENDIX A SPECIAL INTELLIGENCE SPACE INSTALLATIONS

- (U) d. Special color for the cartridges.
- e. Pneumatic tubes shall run through passageways and shall be capable of being visually checked along their entire length.

(U) 50.2.19 Patch panels. In PICS only, RF patch panels are excluded from the separation and identification requirements of 5.3.4 and 5.3.4.1. (NOTE: These RF patch panels may also include IF outputs of radio receivers and time coding signals).

(U) 50.2.20 Destruction equipment. An efficient and secure means of destruction of classified material shall be provided each SI space, or contiguous SI spaces. Destruction equipment, other than paper shredders (NACSI-4010, crosscut type) shall be approved by NAVSEA (Code O3K222) prior to installation. This requirement is not applicable to submarines.

- * (U) 50.2.21 Emergency power. An SI space shall have emergency power sufficient to operate destruction equipment, the alarm system, access control devices, and to provide emergency lighting. Emergency power shall be obtained from the nearest available emergency lighting panel or switchboard.

(U) 50.3 Contingency SI space. The detailed requirements for an SI space as specified in 50.1, 50.2.1 through 50.2.21 are not applicable to a contingency SI space.

(U) 50.3.1 Contingency space perimeter barrier. The physical perimeter barrier of the contingency SI space requires no special construction. The area shall be capable of being "sealed" so as to prevent visual or aural penetration during all operations.

(U) 50.3.2 Contingency space accesses. No special construction requirements are applicable for accesses to contingency SI spaces. Doors shall be capable of being secured from the inside.

- * (U) 50.3.3 Contingency space access marking. Provisions shall be made for posting a temporary sign which reads "RESTRICTED AREA - NO ADMITTANCE BEYOND THIS POINT".

(U) 50.3.4 Contingency space secure storage containers. When SI material or documents are to be stored in the space, a secure storage container conforming to AA-F-358 shall be provided.

UNCLASSIFIED

MIL-STD-1680C(SH)
17 March 1993

APPENDIX A SPECIAL INTELLIGENCE SPACE INSTALLATIONS

(U) Security storage containers shall be welded in place, or otherwise secured to a foundation for safety and to prevent rapid removal.

(U) 50.3.5 Contingency space electrical security. The electrical security requirements for a contingency SI space will be specified by NAVSEA (Code 03K222) on a selective basis.

(U) 50.4 Short term SI space. An SI space created on a temporary basis for shipboard short term one-time deployment not exceeding 9 months shall conform to the minimum physical security criteria set forth below. The criteria is predicated on the space being manned 24 hours a day when there is cryptographic or SI material within the space, and that prior to or at the end of the 9 month period, the short term SI space will be disestablished. If the space is used to electrically process secure information, the full TEMPEST-related configuration control criteria of this standard is required. The minimum physical security criteria for shipboard short term SI space is as follows:

- a. The physical perimeter barrier shall consist of standard structural, structural nonsupport, or metal joiner bulkheads welded or riveted into place.
- b. Doors shall be at least metal joiner doors equipped with door closers and capable of being secured from the inside. Dutch doors are not acceptable. If cryptographic equipment is installed or stored within the space, and the space will be temporarily unmanned while cryptographic key material and SI material are stored elsewhere, the door shall be equipped with a tamper-proof hasp and combination padlock conforming to FF-P-110, type DE, class 2.
- c. Doors, scuttles, vents, louvers or other openings in the perimeter which permit aural or visual penetration of the interior shall be screened, curtained or blocked.
- d. An efficient and secure means of destruction of classified material shall be readily available in the space or nearby in general service spaces.

UNCLASSIFIED

MIL-STD-1680C(SH)
17 March 1993

APPENDIX A SPECIAL INTELLIGENCE SPACE INSTALLATIONS

- * (U) e. Cryptographic equipment processing SI information shall be located in the SI space, or if located in a secure processing center-other than that accredited for SI, shall be electrically configured so as not to be compatible with the classified information processing system of that secure processing system.
- f. A filing cabinet for stowage of classified material.
- * g. Telephone installations shall be as specified in 50.2.13.
- h. Sound powered telephone installations shall be as specified in 50.2.14 and 50.2.14.1.

(U) Additional criteria may be imposed as required on a case-by-case basis.

(U) 50.5 Reports and inquiries. Reports and inquiries applicable to the installation criteria for SI spaces or contingency SI spaces shall provide an information copy to Commander, Naval Investigative Service Command (Code 26T). A copy of reports for SI spaces which process SCI information shall be forwarded to Director, Office of Naval Intelligence (Code 52).

UNCLASSIFIED

MIL-STD-1680C(SH)
17 March 1993

APPENDIX B CLOSED CIRCUIT TELEVISION SYSTEMS

(U) 10. SCOPE

- * (U) 10.1 Scope. This appendix provides the complete installation criteria for Closed Circuit Television Systems (CCTV) which process clear text classified information. This Appendix is a mandatory part of the standard. The information herein is intended for compliance.

(U) 20. APPLICABLE DOCUMENTS

(U) 20.1 Issues of documents. The following documents of the issue in effect on date of invitation for bids or request for proposals, form a part of this appendix to the extent specified herein.

SPECIFICATION

FEDERAL

AA-F-358 - Filing Cabinet, Steel, Legal and Letter Size, Uninsulated, Security.

- * DRAWINGS

- * NAVAL ELECTRONIC SYSTEMS ACTIVITY, ST. INIGOES, MD

NESEA

29357-43583 - STANDARD NIPS AN/SXQ-8(V) CCTV SYSTEM

(U) (Copies of specifications and drawings required by contractors in connection with specific acquisition functions should be obtained from the contracting activity or as directed by the contracting officer.)

(U) 30. DEFINITIONS

(U) 30.1 Audio mix console. Equipment combining facilities for selection, equalization and mixing of various level audio sources to specified level inputs of other equipment and program lines.

(U) 30.2 Balanced system. A line or circuit utilizing two identical conductors. Each conductor is operated so that the voltages on them at any transverse plane are equal in magnitude and opposite in polarity.

UNCLASSIFIED

MIL-STD-1680C(SH)
17 March 1993

APPENDIX B CLOSED CIRCUIT TELEVISION SYSTEMS

(U) 30.3 Baseband video. A signal resulting from television scanning with a bandwidth extending from d.c. to several megaHertz (mHz).

(U) 30.4 Camera control unit. Remotely located controls usually configured for installation in console or rack-type housing and grouped with other similar equipment to facilitate control or operation by a minimum of technical or nontechnical personnel.

(U) 30.5 Closed circuit television. A television network that is not radiated into open space, and therefore not available for interception by non-network viewing stations.

(U) 30.6 Lock-out device. A control apparatus between a viewing station and the television routing switcher which by logic, electrical or mechanical means is capable of controlling which viewing station can select a particular input to the routing switcher.

(U) 30.7 Modulated-carrier system. An RF carrier in which the amplitude or frequency has been varied by a video signal for distribution of a television circuit.

(U) 30.8 Routing switcher. Equipment combining facilities for selections (remote or local) of video, or video and audio sources with suitable outputs to other equipment and program lines.

(U) 30.9 Secure video control space. An area accredited to the generation, control, recording or local monitoring of secure video information. Secure audio signals, associated with the video information may also be processed. The secure video control space is an entity in a space already accorded physical security for level of information to be processed.

(U) 30.10 Secure video viewing space. An area accredited to the display of secure video information. Secure audio signals, associated with the video information, may also be processed. The secure video viewing space is an entity in a space already accorded physical security for the level of information to be processed.

(U) 30.11 Shared television receiver. A television receiver used alternately for viewing a RED CCTV signal and a BLACK television signal.

UNCLASSIFIED

MIL-STD-1680C(SH)
17 March 1993

APPENDIX B CLOSED CIRCUIT TELEVISION SYSTEMS

(U) 30.12 Television receiver. A television viewing device designed and used to receive modulated-carrier television signals.

(U) 30.13 Television receiver (modified). A television receiver which has been modified to accept baseband video signals. The modification shall provide for disabling the RF and IF strips, or disabling the tuner and local oscillator.

(U) 30.14 Television monitor. A television viewing device designed and used to receive baseband video television signals.

(U) 30.15 Television system selector switch. A device used with a television receiver or monitor for alternately viewing RED and BLACK television signals. A minimum isolation of 80 Db in the stopband of 150 Khz to 1 Ghz is required between the RED and BLACK inputs to the device.

(U) 30.16 Unbalanced system. A line or circuit in which the voltages or phases are not balanced.

(U) 30.17 Video distribution amplifier. Distribution amplifier, usually providing four isolated outputs of a source input.

(U) 30.18 Video production switcher. Equipment combining facilities for selection, mixing and processing of a number of video sources with outputs to other video equipment and program lines.

(U) 40. GENERAL REQUIREMENTS

(U) 40.1 Purpose and coverage. The criteria of this appendix shall be applied to Naval ships having a RED CCTV system as specified herein. A RED CCTV system installation in a nonmetallic hull or superstructure shall require specific assessment and approval of NAVSEA (Code 03K222).

(U) 40.2 RED CCTV system. A RED CCTV system shall be a baseband video system in new construction surface ships and new installations in active fleet surface ships. The audio associated with a RED CCTV system shall be a balanced system with audio levels that do not exceed 0 dB as referred to 1 milliwatt (dBm).

UNCLASSIFIED

MIL-STD-1680C(SH)
17 March 1993

APPENDIX B CLOSED CIRCUIT TELEVISION SYSTEMS

(U) 40.3 Closed circuit television TEMPEST-related. RED CCTV systems will often be collocated in a space which has a primary function unable to accommodate the overall TEMPEST-related installation requirements for a secure processing center. Accordingly, the TEMPEST-related criteria of this standard for a secure processing center are not applicable to a secure video control space and a secure video viewing space except where other RED processing equipment is installed. The installation criteria in 50.1 shall be substituted for 5.1 through 5.2.15.1 of the basic standard for such spaces.

(U) 40.4 Closed circuit television physical security. Secure video control spaces and secure video viewing spaces are considered an entity in a space already accorded physical security. Accordingly, the physical security criteria of this standard for a secure processing center are not applicable to a secure video control space and a secure video viewing space except where specifically delineated herein. The physical security criteria in 50.2 shall be substituted for 5.3 through 5.3.6.1 of the basic standard.

(U) 40.5 Commercial equipment. Most CCTV systems will consist of commercial equipment produced in accordance with U.S. industrial standards.

(U) 40.6 Shipboard television systems. The following tabulation of shipboard television systems is provided as an aid for recognizing various interconnections which might exist between RED and BLACK CCTV.

Shipboard Television Systems

IC Circuit
Designator

Name and Description

3TV

General topside surveillance television system. Camera located topside. Remote control of camera from any viewer station via switching facilities. Viewers located at pilot house, central control station or damage control central, safety observers

UNCLASSIFIED

MIL-STD-1680C(SH)
17 March 1993

APPENDIX B CLOSED CIRCUIT TELEVISION SYSTEMS

(U) Shipboard Television Systems (Continued)

IC Circuit
Designator

Name and Description

station, missile operations station, weapons control station, and wardroom.

Switching facilities at master control station. Master control station has facilities for photographically or magnetically recording the video information. System is video only. The system normally processes unclassified information and is considered a BLACK system.

4TV

The CIC Television system. Camera located at automatic summary plotting board. Remote camera control provided. Viewers located at pilot house, flag plot, commanding officer's tactical plot, CIC (detection and tracking area), weapons control area, and helicopter direction area. System is video only. The system normally processes classified information and is considered a RED system.

6TV

General surveillance television system. Cameras located in flight deck area, hangar deck area, machinery spaces, boiler gage glasses, and diver inspection station. Remote control of specific cameras from specific control stations. Viewers located at pilot house, flight deck control, air group line operations, hangar deck control, CIC (air operations area), CIC (traffic control area), central control station, boiler control station. System is video only except for audio from cameras at gallery deck and hangar deck stern. Inputs from 14TV Training and Entertainment System. Outputs to 14TV System and to 9TV Command Briefing System. The system normally processes

UNCLASSIFIED

MIL-STD-1680C(SH)

17 March 1993

APPENDIX B CLOSED CIRCUIT TELEVISION SYSTEMS

(U) Shipboard Television Systems (Continued)

IC Circuit
Designator

Name and Description

unclassified information and is considered a BLACK system.

7TV

Operations Control Television system. Cameras located in operations control area. Remote control for each camera at equipment cabinets and in combat operations center. Viewers located at stations directly concerned with combat operations. Equipment cabinets located in combat operations center. System is video and audio. The system normally processes classified information and is considered a RED system.

8TV

Pilot Landing Aid Television (PLAT) system. Cameras located at canted flight deck, island structure and camera data display board. Viewers located at ready rooms, flag display and briefing, flat plot, pilot house, landing signal officer (LSO) platform, CIC, and training rooms. Video tape recorder located in television control room. System is video and audio. The system normally processes unclassified information and is considered a BLACK system.

* 9TV

Command briefing television. The CVIC briefing television system. Cameras located in CIC (Display and Decision), Tactical Support Center, SSES, CVIC, Meteorological Room, CIC (Surface ops, air ops, strike ops). Viewers located at ready rooms, CVIC, Weapons Coordination Center, pilot house, fly control, flag plot, flag bridge, CIC, Captains sea cabin, Command Center. Video tape recorder, production switcher, video switcher, character generator located in CVIC Mission Planning and Briefing area. System is video and audio. Video routing switcher has inputs from 6TV, 8TV, and 14TV (see

UNCLASSIFIED

MIL-STD-1680C(SH)
17 March 1993

APPENDIX B CLOSED CIRCUIT TELEVISION SYSTEMS

(U) Shipboard Television Systems (Continued)

IC Circuit
Designator

Name and Description

	50.1.7.2). The system normally processes classified information and is considered a RED system.
14TV	Training and entertainment television system. Input to the system is from selectable commercial broadcast channels, film projectors, studio cameras and various remote camera outlet boxes. Viewers located in living spaces, lounges, and specified shops, offices and operational spaces. Equipped with video tape recorders. System is video and audio. Routing switcher has inputs from 6TV and 8TV, and outputs to 6TV and 9TV. The system normally processes unclassified information and is considered a BLACK system.
15TV	Entertainment television antenna distribution system. Provides for reception and distribution of television for entertainment. Viewer outlets provided at Captain's cabin, executive officer's cabin, flag cabin, chief of staff cabin, CPO Lounge, wardroom lounge, and crew recreation room. Provides for demountable omnidirectional antenna. Provides for broadband distribution amplifier.

(U) 40.7 Typical RED CCTV system. Figure 20, Appendix I is a block diagram of a typical shipboard RED baseband video CCTV system. Each equipment shown will not always be in every system.

UNCLASSIFIED

MIL-STD-1680C(SH)
17 March 1993

APPENDIX B CLOSED CIRCUIT TELEVISION SYSTEMS

(U) 50. DETAILED REQUIREMENTS

(U) 50.1 TEMPEST-related CCTV installation criteria.

(U) 50.1.1 RED CCTV system.

* (U) 50.1.1.1 RED CCTV video. A RED CCTV system shall be a baseband video system throughout the distribution network. Modulated carrier systems shall not be installed or utilized for RED CCTV.

* (U) 50.1.1.2 RED CCTV audio. A RED CCTV audio distribution system shall be a balanced system. The audio level shall not exceed 0 dB as referred to 1 milliwatt (dBm), with the exception of the audio between an amplifier and loudspeaker. A RED CCTV audio system shall be separate from BLACK CCTV audio distribution systems.

(U) 50.1.2 RED and BLACK CCTV electrical signal distribution system interfacing. RED and BLACK CCTV shall be interfaced in the electrical signal distribution system only by (see Figure 21, Appendix I):

- a. Routing switches, as specified herein (see 50.1.7.2).
- b. TV system selector switches, as specified herein (see 30.15 and 50.1.6).

(U) 50.1.3 RED CCTV equipment power connection. Each RED baseband CCTV equipment may be permanently connected to a BLACK power panel, or plugged into a convenience outlet wired to BLACK power.

* (U) 50.1.4 Rotary or tone/pulse dial analog telephone lines. Rotary or tone/pulse dial analog telephones which have a capability for connection to shore lines, and located in the same space as a non-SPAWAR TEMPEST-approved RED CCTV equipment, shall have the telephone line filtered. The filter shall provide 100 dB of attenuation within the stopband of 150 kHz to 1 GHz. The filter shall be installed within the room(s) containing the system components. The filter is not required if the telephone is a digital telephone with a buffer amplifier in the receive element.

UNCLASSIFIED

MIL-STD-1680C(SH)
17 March 1993

APPENDIX B CLOSED CIRCUIT TELEVISION SYSTEMS

- * (U) 50.1.5 Equipment separation. RED CCTV systems shall be separated a minimum of 3 feet from BLACK signal processors such as the following:
 - a. Radio transmitters and transceivers.
 - b. Modems and other modulating devices, such as a transmit AN/UCC-1(V) or CV-2460/SGC.
- *
 - c. Remote units of a p/c secure voice system not having filtered transmit audio lines.
 - d. Transfer switchboards having a direct connection to radio transmitters or transceivers, such as transmitter transfer, receiver transfer, frequency selection transfer, data transfer and FSK/RFCs.
 - e. A BLACK teletypewriter equipment with a send capability.
 - f. Control units used with radio transmitters or transceivers, such as C-1004()/SG and C-9351/WSC-3(V).
- * (U) 50.1.6 Television receivers. Television receivers, located in a secure video control or viewing space shall only be connected to an antenna as follows:
 - a. Television receivers used for reception of broadcast signals shall be connected to an antenna only via an antenna distribution system which includes receive RF amplifiers.
 - b. When television receivers are shared in viewing a RED CCTV signal and a BLACK television or CCTV signal in an existing installation, a TV system selector switch (for example, coaxial switch) shall provide receiver selection of the RED or BLACK signal. Such switches shall have a minimum isolation of 80 dB in the stopband of 150 kHz to 1 GHz between RED and BLACK inputs to the switch. When receiving a RED baseband input the receiver shall conform to the requirements of 50.1.7.3.

BLACK television receivers connected directly to an antenna shall not be located in the same room with a RED CCTV system.

UNCLASSIFIED

MIL-STD-1680C(SH)
17 March 1993

APPENDIX B CLOSED CIRCUIT TELEVISION SYSTEMS

(U) 50.1.7 System video.

(U) 50.1.7.1 Unused video terminations. Unused signal input and output connections shall be terminated in their appropriate impedance.

* (U) 50.1.7.2 Routing switcher and production switcher. Routing switchers and production switchers which have both RED and BLACK inputs shall provide 80 dB isolation in the stopband of 300 to 10,000 Hz and 50 kHz to 500 MHz between inputs. If the routing switcher or production switcher cannot provide the 80 dB isolation between inputs, isolation amplifiers may be used in the BLACK input line(s) to achieve the necessary added isolation for a minimum aggregate of 80 dB. Amplifiers used for this purpose become part of the RED system and shall be located within the secure video control space.

(U) 50.1.7.3 Television receivers used with baseband video systems. The TV receivers, modified for a video input, and processing secure video information, shall be additionally modified by disabling the RF and IF strips or the tuner and local oscillator.

(U) 50.1.7.4 RED baseband video outputs. No output shall exist from a RED baseband video system as an input to a BLACK modulated-carrier system.

* (U) 50.1.8 Closed circuit television audio and control cables. RED CCTV cables shall be shielded. RED CCTV audio cables shall be twisted-pair, individually-shielded or overall shielded. RED CCTV audio cables may include RED CCTV control lines. Cables containing only RED CCTV control lines shall be single or multi-conductor with overall shielding.

(U) 50.1.9 Closed circuit television cable separation. For purposes of cable separation (see 5.1.10.12 through 5.1.10.15), a RED CCTV audio distribution system is a low level system when the system is balanced and the audio levels in the electrical signal distribution system do not exceed 0 dBm (1 milliwatt into a 600-ohm load). Power, video and control cables that are part of a baseband video system shall be considered as low level cables.

UNCLASSIFIED

MIL-STD-1680C(SH)
17 March 1993

APPENDIX B CLOSED CIRCUIT TELEVISION SYSTEMS

* (U) 50.1.10 Closed circuit television bonding. The various units of the CCTV system shall be bonded to ground as specified herein.

(U) 50.1.10.1 Bonding of CCTV equipment. RED CCTV equipment shall be bonded to ground using any of the following methods which are most practical and in conformance to the other requirements of the CCTV system:

- a. A class B bond between the equipment chassis or metallic cabinet enclosure and a ground potential support frame or foundation.
- b. A class C bond strap for equipment in a non-metallic enclosure. The bond strap shall be connected between the equipment chassis and ground.
- c. As prescribed by the manufacturer or contractor.
- d. For portable equipment only (for example, camera) via the third wire ground in the power cable or a ground conductor in a control cable.

(U) 50.1.10.2 Bonding of CCTV cable shields. The outer shield of RED CCTV cables shall be bonded to ground at both ends. BLACK CCTV cables which terminate in a RED CCTV equipment (for example, routing switchers) shall have the outer shield bonded to ground at both ends.

(U) 50.2 Physical security.

(U) 50.2.1 Equipment location. Video equipment processing secure video or audio information, or both, shall be located in a secure video control space or a secure video viewing space.

(U) 50.2.2 Closed circuit television audio amplifier or speaker control. Each audio amplifier or loudspeaker, processing the audio associated with a secure video system, shall be capable of being locally adjusted in audio volume level and disconnected from the audio signal line.

UNCLASSIFIED

MIL-STD-1680C(SH)
17 March 1993

APPENDIX B CLOSED CIRCUIT TELEVISION SYSTEMS

- * (U) 50.2.3 Closed circuit television RED coaxial or triaxial continuous cable runs. RED CCTV coaxial and triaxial cables outside of a secure video control space, secure video viewing space, or restricted area shall be run in continuous lengths with no in-line connectors or splices. Bulkhead adapters, if used, shall be totally within the above spaces.

- * (U) 50.2.4 Rotary or tone/pulse dial analog telephones. Rotary or tone/pulse dial analog telephones which have a capability for connection to shore lines, and located in the same space as RED CCTV equipment with a loudspeaker, shall have a push-to-operate feature or a push-to-talk feature with a buffer amplifier in the receive element such as AN/STC-1 or AN/STC-2. The telephone instrument shall be located as far away from the loudspeaker as practical.

- (U) 50.2.5 Closed circuit television video or audio disconnect to viewing spaces. A positive means of disconnecting the RED video and audio to a secure video viewing space shall be provided in the secure video control space. The routing switcher is acceptable for this function.

- (U) 50.2.6 Special intelligence lockout. A lockout device shall be provided in the control apparatus for selective distribution of SI video and audio information. The lockout device shall, by logic, electrical or mechanical means, be capable of controlling which secure video viewing space can select an SI output from the routing switcher. The lockout device shall be located in the secure video control space.

- (U) 50.2.7 Closed circuit television interconnection safeguards. Facilities may exist for the interconnection of BLACK video or audio signals in a RED CCTV system. Such facilities shall provide the necessary safeguards against inadvertent connection of a RED CCTV signal into a BLACK TV or CCTV system. A routing switcher, TV system selector switch or any other unit which has both RED and BLACK cables connected to it shall provide, as a minimum, that RED and BLACK chassis connectors and cables be marked with a symbol designator or functional designator to indicate proper termination.

UNCLASSIFIED

MIL-STD-1680C(SH)
17 March 1993

APPENDIX B CLOSED CIRCUIT TELEVISION SYSTEMS

(U) 50.2.8 Video tape secure storage container. When the RED CCTV system includes a video tape recorder and processes SI information, a security container conforming to AA-F-358 and capable of storing 25 hours of video tape shall be installed in the secure video control space. The security storage container shall be welded in place, or otherwise secured to a foundation for safety and to prevent rapid removal.

(U) 50.2.9 Closed circuit television cable designator. RED CCTV cables shall be marked in accordance with 5.3.1.16.1.

UNCLASSIFIED

MIL-STD-1680C(SH)
17 March 1993

APPENDIX C FIBER OPTIC DISTRIBUTION SYSTEMS

(U) 10. SCOPE

- * (U) 10.1 Scope. This appendix applies supplementary TEMPEST and physical protection installation criteria for shipboard fiber optic distribution systems used for processing classified clear text information up to Top Secret (TS) and including special category information (special intelligence information, etc). This appendix is a mandatory part of the standard. The information contained herein is intended for compliance.

* (U) 20. APPLICABLE DOCUMENTS

- (U) 20.1 This section is not applicable to this Appendix.

(U) 30. DEFINITIONS

- (U) 30.1 This section is not applicable to this Appendix.

(U) 40. GENERAL REQUIREMENTS.

- (U) 40.1 Purpose and coverage. The criteria of this appendix shall be applied to a ship that processes secure electrical and optical information in a fiber optic distribution system.

(U) 50. DETAILED REQUIREMENTS

- (U) 50.1 TEMPEST-related installation criteria.

- (C) 50.1.1 Electrical or electronic portions of fiber optic system.

UNCLASSIFIED

MIL-STD-1680C(SH)
17 March 1993

APPENDIX C FIBER OPTIC DISTRIBUTION SYSTEMS

(C) 50.1.2 Fiber optic parts.

(U) 50.2 Physical protection. The physical protection considerations of distribution systems utilizing fiber optic parts are essentially the same as already established for wire line systems as described herein, except as specified herein.

(U) 50.2.1 Fiber optic cable marking. As fiber optic cables require no physical separation from other cables, they shall not be identified with security markings or color designator, regardless of the security level of information being processed.

* (U) 50.2.2 Fiber optic cables processing TS or SI information. Splicing of fiber optic cable runs processing TS or SI information external to an area accredited that level of security shall be avoided. The cable shall not break out (for example, to a distribution system) at any point along its entire run except in an area accredited that level of security. Cables installed external to an SI space or restricted area shall be installed so that they can be visually inspected. If the cable passes through normally-locked areas (for example, voids, staterooms, storerooms), that portion of the cable shall be contained in metallic conduit. If a junction box is required, it shall be tack welded or locked with a combination padlock conforming with FF-P-110, type DE, class 2, installed at opposite ends, so that an overt attempt to penetrate the box will be obvious.

UNCLASSIFIED

MIL-STD-1680C(SH)
17 March 1993

APPENDIX C

FIBER OPTIC (Continued)

(U) 50.2.3 Switching matrix. All remote terminals in a fiber optic system processing TS or SI information shall have a switching matrix installed in an area accredited that level of security. The switching matrix shall have the capability to select single or multiple stations and to disconnect, connect and cross-connect remote stations.

UNCLASSIFIED

MIL-STD-1680C(SH)
17 March 1993

APPENDIX D

SPAWAR TEMPEST-APPROVED EQUIPMENT AND SYSTEMS

(U)

10. SCOPE

- * (U) 10.1 Scope. This appendix is a tabulation of shipboard SPAWAR TEMPEST-approved equipment and systems (see 3.56). The tabulation is intended as an aid to the personnel engaged in planning, installation and inspection of shipboard secure electrical information processing systems. This tabulation includes those equipments installed in ships listed in the current and previous editions of the Endorsed TEMPEST Products List (ETPL) of the Information Systems Security Products and Services Catalog which is revised quarterly, and those equipments which have received AUTODIN Category II certification. Only that equipment which has a military nomenclature, or listed in the ETPL, which is currently installed on ships or planned for future installation is included in this tabulation. Equipments identified for Zones 0-3 in the TEMPEST Alternatives Data Book (C), although not included in the tabulation, meet the requirements of 3.56 and can be applied as equipments in 50.1 status. This appendix is a mandatory part of the standard. The information herein is intended for compliance.

(U)

20. APPLICABLE DOCUMENTS

PUBLICATIONS

NATIONAL SECURITY AGENCY

Information Systems Security Products and Services Catalog (Contains the Endorsed and Potential TEMPEST Products Lists)

(U)

30. DEFINITIONS

- (U) 30.1 This section is not applicable to this appendix.

(U)

40. GENERAL REQUIREMENTS

(U) 40.1 Equipment Groupings. There are four separate groupings of equipment which will indicate their TEMPEST status pertaining to the application of shipboard installation requirements.

- a. SPAWAR TEMPEST-approved equipment, as defined in 3.6. The most significant feature of this grouping is that the equipment does not require RED power. The status of SPAWAR TEMPEST-approved may affect other areas of the installation standards such as cable separation and

UNCLASSIFIED

MIL-STD-1680C(SH)
17 March 1993

APPENDIX D

SPAWAR TEMPEST-APPROVED EQUIPMENT AND SYSTEMS

- (U) secure voice. SPAWAR TEMPEST-approved equipment and systems are listed in 50.1.
- b. SPAWAR TEMPEST-approved RED/BLACK signal interface equipment includes isolation devices as defined in 3.25 and applied in 5.1.1. The significant feature of this grouping is that there is adequate signal isolation between an equipment's or system's RED and BLACK signal lines. Other than for cryptographic units, if an equipment has a signal interface to both RED and BLACK, it should be in this grouping. Cryptographic units are assumed to have inherent RED/BLACK signal isolation. SPAWAR TEMPEST-approved RED/BLACK signal interface equipments are listed in 50.2.
- c. RED low level signal equipments are those equipments having RED signal and control line input/outputs as defined in 3.44, but are not SPAWAR TEMPEST-approved. These equipments shall be installed the same as the SPAWAR TEMPEST-approved equipment in 40.1.a. or b. above. Subsequent TEMPEST tests may result in revised installation criteria for these equipments. These equipments are listed in 50.3. Proposals for use of equipment that is neither SPAWAR TEMPEST-approved nor listed in 50.3 must be approved by NAVSEA (Code 06K222) prior to installation.
- d. Non-SPAWAR TEMPEST-approved low level equipments having RED signal and control line input/outputs as defined in 3.44 where TEMPEST testing has determined that RED primary power is required.

(U) 40.2 Military type designators. The following applies to equipment which uses military type designators listed in 50.1 through 50.4. If the designator is intended to apply to all existing model modifications, parenthetical bowlegs will be used instead of individual alphabetical suffixes. The (V) symbol for variant, when used without a numerical suffix, will indicate that all variants are included.

UNCLASSIFIED

MIL-STD-1680C(SH)
17 March 1993

APPENDIX D

SPAWAR TEMPEST-APPROVED EQUIPMENT AND SYSTEMS

(U) 50. DETAILED REQUIREMENTS

(U) 50.1 SPAWAR TEMPEST-approved equipment and systems. The following SPAWAR TEMPEST-approved equipments and systems are acceptable for shipboard installation as RED low level teletypewriter/data, secure voice and other system applications as identified. This listing does not include the category of equipment or systems that are approved RED/BLACK Signal interfaces (isolation devices) (see 50.2).

<u>TYPE DESIGNATION</u>	<u>ITEM NAME</u>	<u>SYSTEM APPLICATION</u>
AJ-11R	Extel Printer	All
AM-215()/U	Audio Frequency Amplifier	Secure Voice
AM-2319/WIC	Amplifier-loudspeaker	Secure voice
AM-3729()/SR	Audio Frequency Amplifier	Secure voice
AM-4453()/U	Audio Frequency Amplifier	Secure voice
AM-6949()/USC	Audio Frequency Amplifier	Secure voice
AN/GGC-55(V)1 through (V)3	Teletypewriter Set	All
AN/GGC-59(V)5 through (V)7 and (V)13 through (V)17	Teletypewriter Set	All
AN/SGC-6	Teletypewriter Set	All
AN/SGC-7	Teletypewriter Set	All
AN/SGC-8	Teletypewriter Set	All
AN/SGC-9	Teletypewriter Set	All
AN/SGC-10	Teletypewriter Set	All
AN/SGC-11	Teletypewriter Set	All
AN/SGC-12	Teletypewriter Set	All
AN/SGC-13	Teletypewriter Set	All
AN/SGR-1	Teletypewriter Set	All
AN/SGR-2	Teletypewriter Set	All

UNCLASSIFIED

MIL-STD-1680C(SH)
17 March 1993

APPENDIX D

SPAWAR TEMPEST-APPROVED EQUIPMENT AND SYSTEMS

(U) 50.1 (Cont'd)

<u>TYPE DESIGNATION</u>	<u>ITEM NAME</u>	<u>SYSTEM APPLICATION</u>
AN/SYQ-6(V) consisting of: AN/USC-29(V) AN/UYA-9(V) AN/UYC-3(V)2 C-3414/USQ-20(V) C-9147/SYQ-6(V) C-9148/SYQ-6(V) C-9149/SYQ-6(V) CP-642B/USQ-20(V) ID-1852/SYQ-6(V) MT-4481-UG MT-4482/USC-29 MU-570/USQ-20(V) PU-491/USQ-20(V) RD-281(V)/UYK RD-294(V)/UYK SA-1883/SYQ-6(V) SA-1884/SY1-6(V) SB-1299B/USQ-20(V) TD-1066/SYQ-6(V) TT-624(V)/UG	Message Processing and Distribution System	CVN-68 CLASS Message Processing and Distribution System
AN/UGC-48()	Teletypewriter Set	Low level TTY
AN/UGC-49()	Teletypewriter Set	Low level TTY
AN/UGC-61()	Teletypewriter Set	Low level TTY
AN/UGC-74A(V)3	Communications Terminal	All
AN/UGC-77	Teletypewriter Set	Low level TTY
AN/UGC-78	Teletypewriter Reperforator Set	Low level TTY
AN/UGC-91	Teletypewriter Set	Low level TTY
AN/UGC-126()	Teletypewriter Set	All
AN/UGC-127	Teletypewriter Set	All
AN/UGC-129(V)1	Teletypewriter Set	All
AN/UGC-136AX	Teleprinter Set	All
AN/UGC-143A(V)	Teletypewriter Set	Low level TTY
AN/UGR-6A	Teletypewriter Transmitter-Distributor Set	Low level TTY
AN/UGR-9	Teleprinter Set	Low level TTY
AN/UGR-10()	Teleprinter Set	Low level TTY
AN/UGR-16	Teleprinter Set	Low level TTY

UNCLASSIFIED

MIL-STD-1680C(SH)

17 March 1993

APPENDIX D

SPAWAR TEMPEST-APPROVED EQUIPMENT AND SYSTEMS

(U) 50.1 (Cont'd)

<u>TYPE DESIGNATION</u>	<u>ITEM NAME</u>	<u>SYSTEM APPLICATION</u>
AN/UGR-25	Teleprinter Set	All
AN/UYK-20()(V)	Data Processing Set Crypto	All
AN/UYK-22	Ancillary Unit Models 2100/2200 at 9.6 kbps and Models 3100/3200/3300/3400 at 56 kbps	AUTODIN
AN/UYQ-21(V)	Computer-Display Set	Secure voice; does not apply to units other than LS- 653 UYQ-21, LS- 654/UYQ-21, and ON-201(V)/UYQ-21
AN/WRR-7	Digital Data Receiving Set including: MD-855/WRR-7 Demodulator-Power Supply	VERDIN system
Astronautics	CP-1071/WR Digital Data Processor Standard Remote Terminal including: 401G (P/N 202501) Line Control Unit 7T-200/556 (P/N 202621) Magnetic Tape Unit 9T-800 (P/N 202623) Magnetic Tape Unit 9T- 1600 (P/N 202634) Magnetic Tape Unit (P/N 202605) Disk (P/N 202607) Paper Tape Punch (P/N 202606) Paper Tape Reader (P/N 202604) Card Punch (TEMPEST Cabinet) (P/N 202603) Card Reader (P/N 202599) Low Speed Page Printer (P/N 202600) Medium Speed Line Printer (P/N 202620) High Speed Line Printer (P/N 202598) OSU Optical Scan Unit	AUTODIN

UNCLASSIFIED

MIL-STD-1680C(SH)
17 March 1993

APPENDIX D

SPAWAR TEMPEST-APPROVED EQUIPMENT AND SYSTEMS

(U) 50.1 (Cont'd)

<u>TYPE DESIGNATION</u>	<u>ITEM NAME</u>	<u>SYSTEM APPLICATION</u>
Naydin Corp. Model 5807/WWMCCS	Graphics Terminal	All
Bendix Corp. Model BHP-2600	Secure Interactive Alpha-numeric Display Terminal	Data at 9600 Baud only
Model HSP 3609-80	MILTOPE Teleprinter	
C-7594A/U	Remote Switching Control	Secure voice
C-7595()U	Remote Switching Control	Secure voice
C-8151/U	Remote Switching Control	Secure voice
C-10276/U	Control-Indicator	Secure voice
C-10315/U	Remote Switching Control	Secure voice
C-10979/U	Remote Switching Control	Secure voice
Chromatics Model CGC-7900	Color Graphics Computer	All
CN/1530/7	Audio Muting Unit	Secure voice
Compucorp Model 775T	Word processor	All
CV-2757/SGC	Converter-Repeater	Low level TTY
CV-3333/U	Audio-Digital Converter	Secure voice
CV-3971/S	Converter Interface Unit	TTY System
CV/4000	Converter Interface Unit	TTY System
Dataproducts New England Models 2100/2200 (0.6 KBPS) 3100/3200/3300/3400 (56 KBPS)	Crypto Ancillary Unit	AUTODIN
Dataproducts New England Model 2237	Printer	AUTODIN
Dataproducts New England Model 2297	High speed line printer	All
Dataproducts New England Model 2910	TEMPEST Military Teleprinter	All
Dataproducts New England Model 5600	Crypto Ancillary Unit	AUTODIN
Dataproducts New England Model MC3	Multi-Channel Crypto Controller	All
Dataproducts New England Model MC3-188/114	Multi-Channel Crypto Controller with 188/114 Interface	All

UNCLASSIFIED

MIL-STD-1680C(SH)
17 March 1993

APPENDIX D

SPAWAR TEMPEST-APPROVED EQUIPMENT AND SYSTEMS

(U) 50.1 (Cont'd)

<u>TYPE DESIGNATION</u>	<u>ITEM NAME</u>	<u>SYSTEM APPLICATION</u>
Dataproducts New England Model MXT-1200C	Receive-only printer	All
Dataproducts New England Model MXT-1200 KSR	KSR printer	All
GTE Sylvania Model MRD-2000	Multi-Rate Digitizer	All
GTE Sylvania Model MRD-2000-2	Multi-Rate Digitizer	All
Honeywell Model CT-16 H316R CPU/4600-1 Series 16-5100 MLP-12	Terminal including: AUTODIN Control Unit Card Reader Line Printer	AUTODIN
IBM Corp. 3262RC Model 3 RPO MNO234	High Speed Line Printer	All
IBM Corp. 3278RC Model 2 RPO 8K1069	CRT Display Station	All
IBM Corp. 5215T Model 001 or 12PO 8A0063	Selective Element Printer	All
IBM Corp. Model 6580	Test Processor Work station; consists of modified electronics module, 25 line display and keyboard	All
ID-2219/U	Audio Signal Monitor- Mixer Unit	Secure voice
INTEQ Model 1A-5100	Modular Communications AUTODIN	All
INTEQ Model 1B-5100	Modular Communications AUTODIN	All
INTEQ Model 3A-5100	Modular Communications AUTODIN	All
INTEQ Model LP-5100A LS-518()/SIC	Line Printer Intercommunication Station	All 12MC intercom
LS-653/UYQ-21	Intercommunication Station	Secure voice
LS-654/UYQ-21	Intercommunication Station	Secure voice

UNCLASSIFIED

MIL-STD-1680C(SH)
17 March 1993

APPENDIX D

SPAWAR TEMPEST-APPROVED EQUIPMENT AND SYSTEMS

(U) 50.1 (Cont'd)

<u>TYPE DESIGNATION</u>	<u>ITEM NAME</u>	<u>SYSTEM APPLICATION</u>
MU-734/UGC	TTY Magnetic Tape Unit	All
ON-143(V)3/USQ	Interconnecting Group	NAVMACS
ON-143(V)4/USQ	Interconnecting Group	Data processing and secure voice
ON-143(V)5/USQ	Interconnecting Group	SSIXS (NOTE: RED power required when associated hard copy print out unit is high level)
ON-143(V)6/USQ	Interconnecting Group	Data processing
ON-143(V)7/USQ	Interconnecting Group	Data processing
ON-143(V)9/USQ	Interconnecting Group	NAVMACS
ON-201(V)UYQ-21	Intercommunications Interconnect Group	Including: SB-4067/UYQ-21
Intercommunication Switchboard, C-10820/UYQ-21	Secure Voice	
OP-94/S	Power Supply	Low level TTY
RD-379(V)/UNH (TR-1710D/T)	Multichannel Recorder-Reproducer	Secure voice
RD-390(V)/UNH (TR-1720D/T)	Multichannel Recorder-Reproducer	Secure voice
RD-396/UG	Signal Data Recorder-Reproducer	NAVMACS
RD-397(V)/U	Signal Data Recorder-Reproducer	NAVMACS/TACINTEL
RD-397B(V)/U	Signal Data Recorder-Reproducer	NAVMACS/TACINTEL
RD-433/SSH	recorder-Reproducer	NAVMACS/TACINTEL and Flag Data Display System
Rixon Model SN-394	Crypto Ancillary Unit	TACINTEL/NAVMACS
SA-734/SG	Switch box	AUTODIN
SA/1007/U	Switch box	Shared TTY
SA-1539/S	Lock Switch	Secure voice
SA-1711()/UR	Switching Unit	Secure voice
SA-1722/UYK	Rotary Switch	Secure voice
SA-1794/UG	TTY Switching Unit	Low level TTY

UNCLASSIFIED

MIL-STD-1680C(SH)
17 March 1993

APPENDIX D

SPAWAR TEMPEST-APPROVED EQUIPMENT AND SYSTEMS

(U) 50.1 (Cont'd)

<u>TYPE DESIGNATION</u>	<u>ITEM NAME</u>	<u>SYSTEM APPLICATION</u>
SA-1816/UYK	Rotary Switch	Data processing
SA-2076/UGQ	Low level Switch Assembly	Low level TTY
SA-2081/UR	Switching Unit	Secure voice
SA-2112(V)/STQ	Switching Matrix	Secure voice
SA-2128/SIC	Switching Matrix	12MC intercom
SA-2215/U	Digital Signal Switching Unit	Data processing
SA-2371/SG	Low level Switch Box	Shared TTY
Sanders Associates, Inc Model Graphic 8	Color Terminal	All
SB-82()/SRR	Receive Transfer Switchboard	Secure voice
SB-863/SRT	Transmitter Transfer Switchboard	Functional Remote Switchboard
SB-973/SRR	Receive Transfer Switchboard	Secure voice
SB-1299(V)/USQ-20	Signal Distribution Switchboard	Secure/non-secure switching
SB-3145/UG	Communication Switch Panel	Low level TTY
SB-3146/UG	Communication Patch Panel	Low level TTY
SB-3149/UG	Ballast Lamp-Fuse Panel	Low level TTY
SB-3176/UGQ	Communication Patch Panel	Low level TTY
SB03189()/FGC	Communication Patch Panel	Low level TTY
SB-3195/U	Receive Transfer Switchboard	Crypto timing
SB-3372/US	Transfer switchboard	Secure/non-secure switching
SB-3453A/UG	Switchboard	Low level TTY
SB-3495()(V)/UYK	Signal Distribution Switchboard	Data processing
SB-3503/FG	Fuse Panel	Low level TTY
SBB-3686/UG	TTY Signal Switchboard	Low level TTY
SB-3692/UG	Communication Patch Panel	Low level TTY

UNCLASSIFIED

MIL-STD-1680C(SH)
17 March 1993

APPENDIX D

SPAWAR TEMPEST-APPROVED EQUIPMENT AND SYSTEMS

(U) 50.1 (Cont'd)

<u>TYPE DESIGNATION</u>	<u>ITEM NAME</u>	<u>SYSTEM APPLICATION</u>
SB-3846()/UG	Power Distribution	Low level TTY
SB-3879/US	Transfer Switchboard	Data processing
SB-4074/UG	Signal Data Patch Panel	Low level TTY
SB-4075/UG	Signal Data Patch Panel	Low level TTY
Sperry-UNIVAC Model DCT 9000	AUTODIN Terminal: Processor Cabinet, Printer, Card Reader, Card Punch, UNISERVO VI- C (EBCDIC/Odd Parity Only), Paper Tape Reader/Paper Tape Punch (with power line filter mod kit), and DLT-70	AUTODIN
Sperry-UNIVAC Model UTS-40	Video Display Terminal	All
TA-734/U	Telephone Set	Secure voice
TA-790/U	Telephone Set	Secure voice
TA-840()/U	Telephone Set	Secure voice
TA-970/U	Telephone Set	Secure voice
TA-980/U	Telephone Set	Secure voice
TA-990/U	Telephone Set	Secure voice
Tektronix Model 40141 Mod EM	Terminal/Hard Copy Unit	All
Tektronix Model 4631 Mod EM	Terminal/Hard Copy Unit	All
Teletype Corp Model 40/8 (A-D)	TTY Terminals	All
Teletype Corp. Model 40/8A	Receive-only printer, and Keyboard/printer terminals	All
Teletype Corp. Model 40/8BII	Terminal, line printer & 3 cassettes	All
TT-570/UG	TTY Transmitter- Distributor	Low level TTY
TT-571/UG	TTY Reperforator Set	Low level TTY
TT-576()/UG	TTY Reperforator Set	Low level TTY
TT-577/UG	TTY Reperforator Set	Low level TTY
TT-603/UG	TTY Transmitter- Distributor	Low level TTY

UNCLASSIFIED

MIL-STD-1680C(SH)
17 March 1993

APPENDIX D

SPAWAR TEMPEST-APPROVED EQUIPMENT AND SYSTEMS

(U) 50.1 (Cont'd)

<u>TYPE DESIGNATION</u>	<u>ITEM NAME</u>	<u>SYSTEM APPLICATION</u>
TT-605/UG	TTY Reperforator	Low level TTY
TT-624()(V)/UG	Teleprinter	Low level TTY
Western Union Crypto Ancillary Unit Dataproducts New England Model 5602	Crypto Ancillary Unit with Model UM-EIA modem up to 1.2 kbps; without Model UM-EIA modem up to 56 kbps	AUTODIN
Xerox Corp. Model 190T	Single (LSI) Disk Drive for the 860T	All
Xerox Corp. Model 228T	Dual Sided Disk Drive for the 860T	All
Xerox Corp. Model 610CT	Memorywriter with Communications	All
Xerox Corp. Model 610T	Memorywriter-Electronic Typewriter	All
Xerox Corp. Model 690T	Model 860T Communication Accessory (RS-232C)	All

(U) 50.2 RED/BLACK signal interfaces. The following equipments and systems are acceptable for shipboard installation as a RED/BLACK signal interface (see 5.1.1) in the system application as identified.

<u>TYPE DESIGNATION</u>	<u>ITEM NAME</u>	<u>SYSTEM APPLICATION</u>
AM-6949()/USC	Audio Frequency Amplifier	Secure voice
AN/SGC-6	TTY Set	All
AN/SGC-7	TTY Set	All
AN/SGC-8	TTY Set	All
AN/SGC-9	TTY Set	All
AN/SGC-10	TTY Set	All
AN/SGC-11	TTY Set	All
AN/SGC-12	TTY Set	All
AN/SGC-13	TTY Set	All
AN/SGR-1	TTY Set	All
AN/SGR-2	TTY Set	All
AN/UGC-74A(V)3	Communications Terminal	All
AN/UGC-126()	TTY Set	All
AN/UGC-127	TTY Set	All
AN/UGC-129(V)1	TTY Set	All
AN/UGC-136AX	Teleprinter Set	All

UNCLASSIFIED

MIL-STD-1680C(SH)
17 March 1993

APPENDIX D

SPAWAR TEMPEST-APPROVED EQUIPMENT AND SYSTEMS

(U) 50.2 (Cont'd)

<u>TYPE DESIGNATION</u>	<u>ITEM NAME</u>	<u>SYSTEM APPLICATION</u>
AN/UGC-143A(V)	TTY Set	All
AN/UGR-25	Teleprinter Set	All
AN/WRR-7	Digital Data Receiving Set including: MD-855/WRR-7 Demodulator-Power Supply CP-1071/WR Digital Data Processor	VERDIN system
Aydin Corp. Model 5807/WWMCCS	Graphics Terminal	All
C-7594A/U	Remote Switching Control	Secure voice
C-7594B/U	Remote Switching Control	Secure voice
C-7595A/U	Remote Switching Control	Secure voice
C-7595B/U	Remote Switching Control	Secure voice
C-10315/U	Remote Switching Control	Secure voice
CV-2757/SGC	Converter-Repeater	Clock only
CV-3971/S	Converter Interface Unit	Teletype System
CV-4000	Converter Interface Unit	Teletype System
Dataproducts New England Model MXT-1200C	Receive-only printer	All
INTEQ Model 1A-5100	Modular Communications	All
INTEQ Model 1B-5100	Modular Communications AUTODIN Terminal	All
INTEQ Model 3A-5100	Modular Communications AUTODIN Terminal	All
INTEQ Model LP-5100A	Line Printer	All
LS-653/UYQ-21	Intercommunication Station	Secure voice
LS-654/UYQ-21	Intercommunication Station	Secure voice
MU-734/UGC	Teletype Magnetic Tape Unit	All
ON-143(V)3/USQ	Interconnecting Group	NAVMACS, TACINTEL
ON-143(V)4/USQ	Interconnecting Group	Data processing and secure voice
ON-143(V)5/USQ	Interconnecting Group	SSIXS (NOTE: RED Power required when associated hard copy printout TTY equipment H/L)

UNCLASSIFIED

MIL-STD-1680C(SH)
17 March 1993

APPENDIX D

SPAWAR TEMPEST-APPROVED EQUIPMENT AND SYSTEMS

(U) 50.2 (Cont'd)

<u>TYPE DESIGNATION</u>	<u>ITEM NAME</u>	<u>SYSTEM APPLICATION</u>
ON-201(V)/UYQ-21	Intercommunications Interconnect Group including: C-10820/UYQ- 21 Intercommunication Control, PP-7629/UYQ-21 Power Supply, SB-4067/UYQ-21 Intercommunication Switchboard	Secure voice
RD-379(V)/UNH (TR-1710D/T)	Multichannel Recorder- Reproducer	Secure voice
RD-390(V)/UNH (TR-1720D/T)	Multichannel Recorder- Reproducer	Secure voice
SA-734/SG	Switch Box	Shared teletypewriter
SA-1997/U	Switch Box	Secure voice
SA-2112(V)/STQ	Switching Matrix	Secure voice
SA-2371	Low Level Switch Box	Shared Teletypewriter
Sanders Associates	Model Graphic 8	Color Terminal
SB-82()/SRR	Receive Transfer Switchboard	Secure voice
SB-973/SRR	Receive Transfer Switchboard	Secure voice
SB-1299(V)/USQ-20	Signal Distribution Switchboard	Secure/non-secure switching
SB-3372/US	Transfer Switchboard	NTDS Link 11
SB-3879/U	Transfer Switchboard	NTDS Link 11
Sperry-UNIVAC Model UTS-20	Video Display Terminal	All
Sperry-UNIVAC Model UTS-40	Video Display Terminal	All
TA-734/U	Telephone Set	Secure voice
TA-790/U	Telephone Set	Secure voice
TA-840/U	Telephone Set	Secure voice
TA-970/U	Telephone Set	Secure voice
TA-980/U	Telephone Set	Secure voice
TA-990/U	Telephone Set	Secure voice
Tektronix Model 4631 Mod EM	Terminal/Hard Copy Unit	All

UNCLASSIFIED

MIL-STD-1680C(SH)
17 March 1993

APPENDIX D

SPAWAR TEMPEST-APPROVED EQUIPMENT AND SYSTEMS

(U) 50.2 (Cont'd)

<u>TYPE DESIGNATION</u>	<u>ITEM NAME</u>	<u>SYSTEM APPLICATION</u>
Teletype Corp. Model 40/8 (A-D)	Teletype Terminal	All
Teletype Corp. Model 40/8A	Receive-only printer, and Keyboard/printer terminal	All
Teletype Corp. Model 40/8BII	Terminal, line printer & 3 cassettes	All
Xerox Corp. Model 860T & RX860T with P1(324T) Printer	Information Processing System 10 & 12 Pitch Printing and Automatic Paper Feeder (128K & 256K Memory)	All

(U) 50.3 Low level equipment not qualifying as SPAWAR TEMPEST-approved. Equipments having low level signal inputs/outputs that are frequently used in a RED processing system, but have not qualified as SPAWAR TEMPEST-approved. With the exception of specific equipments listed in 50.4, the following equipments or systems shall be connected to BLACK primary power.

<u>TYPE DESIGNATION</u>	<u>ITEM NAME</u>	<u>SYSTEM APPLICATION</u>
AM-6210/U	Audio Frequency Amplifier	Secure voice
AM-6694/SR	Audio Frequency Amplifier	Secure voice
AN/BSC-1	Communication Central	SSBN-726 Class
AN/SLQ-32(V)	Countermeasure Set	Data processing
AN/SLR-16	Countermeasure Receiving Set	PICS
AN/SLR-23	Countermeasure Receiving Set	PICS
AN/SQQ-28(V)/LAMPS MK III	Sonar Signal Processing Set	Data processing
AN/SQQ-89(V)	Underwater Sensor System	All
AN/SQR-17	Sonar Signal Processing Set	All
AN/SQR-19	Sonar Receiving Set	Data processing
AN/SQS-53B	Sonar Detecting Ranging Set	Data processing

UNCLASSIFIED

MIL-STD-1680C(SH)
17 March 1993

APPENDIX D

SPAWAR TEMPEST-APPROVED EQUIPMENT AND SYSTEMS

(U) 50.3 (Cont'd)

<u>TYPE DESIGNATION</u>	<u>ITEM NAME</u>	<u>SYSTEM APPLICATION</u>
AN/SRD-19	Direction Finder Set	PICS
AN/SXQ-8(V)	Television System	CCTV
AN/SRQ-4	Radio-telemetric Terminal Set	LAMPS III
AN/SRS-1	Combat Direction Finder	Data processing
AN/SYQ-9(V)	Digital Data Processing System	Data processing
AN/TNH-20A(V)	Sound Recorder- Reproducer Set	PICS
AN/USH-22(V)	Signal Data Recorder- Reproducer	FLTSATCOM
AN/USH-26(V)	Signal Data Recorder- Reproducer	NAVMACS; TACINTEL
AN/USQ-20	Data Processing Set	NTDS
AN/USQ-81(V)	Tactical Data Display System	OUTLAW SHARK
AN/UXC-4	Facsimile Set	Data processing
AN/UYA-5	Input/Output Data Display Group	Data processing
AN/UYA-7	Digital Data Group	Data processing
AN/UYH-2(V)	Disk Memory Set	Data processing
AN/UYH-3(V)	Magnetic Disk Recorder-Reproducer Set	Data processing
AN/UYK-7(V)	Computer	Data processing
AN/UYK-19(V)	Data Processing Set	Data processing see 50.1 and 50.2 for the LS-653/UYQ-21, LS- 654/UYQ-21 and ON- 201(V)/UYQ-21
AN/UYK-79	Rugged Combat Support Disk	All
AN/UYQ-23(V)	Computer Display Set	Data processing
AN/UYQ-25	Data Processing Set	Data processing
AN/UYQ-52(V)	Combat Support Display	All
CP-642B/USQ-20(V)	Digital Data Computer	Data processing
CV-3046/U	Digital Data Converter	NTDS
CV-3145/UYK	Computer Adapter Converter	NTDS

UNCLASSIFIED

MIL-STD-1680C(SH)

17 March 1993

APPENDIX D

SPAWAR TEMPEST-APPROVED EQUIPMENT AND SYSTEMS

(U) 50.3 (Cont'd)

<u>TYPE DESIGNATION</u>	<u>ITEM NAME</u>	<u>SYSTEM APPLICATION</u>
IP-1243/UYK	Digital Display Indicator	Data processing
J-4306/S	RAST Interface Box	Helo Recovery
J-4704/U	Crypto Interface Unit	All
Mobile Team Training Unit	Training Van	AN/SQQ-28(V)/LAMPS
MU-602(V)/UYK	Core Memory Unit	Data processing
OA-7984(V)/UYK	Input/Output Console	NTDS
OA-8703/USQ	Monitor-Analysis Group	Data processing
OA-8911/SGC	TTY Signal Switching Group	Data processing
OJ-172(V)/UYK-7	Input/Output Console	NTDS
OJ-207/UYA-5	Control-Multiplex	Data processing
OJ-230/UYA	Message Console	Data processing
OJ-212(V)/UYK	Input/output Console	NTDS
OK-324/SYQ	Communication Control Group	Data processing
PP-6521/FG	Power Supply Assembly	Low level TTY
PP-8199/U	Versitron, Power Supply	All
RD-358(V)/UYK	Digital Magnetic Tape Recorder-Reproducer	Data processing
RO-280/UYK	Data Processing Line Printer	Data processing
TD-1194(V)/UYK	Controller-Multiplexer	Data processing
TH-83()/FGC	Telegraph-Repeater	Low level teletypewriter
TT-649/UY	Line Printer	Data processing
	Baseband CCTV Systems	All
	OUTBOARD	All
	Common Weapon Control System	All
	Tomahawk Weapon System	All

(U) 50.4 Low level equipment requiring connection to RED primary power. Equipment in this group are low level equipments that shall be connected to RED primary power. Equipment in this

UNCLASSIFIED

MIL-STD-1680C(SH)
17 March 1993

APPENDIX D

SPAWAR TEMPEST-APPROVED EQUIPMENT AND SYSTEMS

(U) category may be part of a system listed in 50.3, however, connection to RED primary power for these specific equipments is required.

AN/USQ-69(V)
HP-3964A

Data Terminal Set
Four Channel Tape
Recorder

Data processing
OUTBOARD II

UNCLASSIFIED

MIL-STD-1680C(SH)
17 March 1993

APPENDIX E

COMBAT SYSTEM SHIP LAND BASED TEST SITE

(U) 10. SCOPE

(U) 10.1 Scope. This appendix sets forth the design and installation criteria applicable to the secure electrical information processing system in a Combat System of a Ship Land Based Test Site (SLBTS) as defined herein, including detailed hardware and equipment requirements and the applicable inspection and reporting procedures and documentation. This Appendix is a mandatory part of the standard. The information contained herein is intended for compliance.

(U) 10.2 Application. This appendix is applicable to a SLBTS that plans to process classified information within the secure electrical information processing system. The requirements of this standard and the appendices as would be applied to a metallic hull surface ship shall be applied to the combat system of an SLBTS.

(U) 10.3 Precedence. Where this appendix is in conflict with the basic document or Appendices A, B, or C, this appendix takes precedence.

(U) 20. APPLICABLE DOCUMENTS

(U) 20.1 See basic document.

(U) 30. DEFINITIONS

* (U) 30.1 Electrical perimeter barrier. The electrical perimeter barrier is the installation boundary that encloses the classified information processing system to preclude detection of CE outside the physical perimeter barrier of the Combat systems SLBTS. The physical perimeter barrier provides the physical security to a secure processing center; the electrical perimeter barrier provides the electrical security to the classified information processing system within a secure processing center. (Note: Electrical perimeter barrier, as defined in 3.14, does not apply to Appendix E.)

(U) 30.2 Ground (electronic ground). An electrical reference point of zero potential with respect to other points of the electrical distribution system. At the Combat Systems SLBTS, the

UNCLASSIFIED

MIL-STD-1680C(SH)
17 March 1993

APPENDIX E

COMBAT SYSTEM SHIP LAND BASED TEST SITE

(U) ground potential will be the structural ground. (NOTE: Ground (electronic ground) as defined in 3.20, does not apply to Appendix E).

(U) 30.3 Ship land based test site. An SLBTS is a facility duplicating/simulating as many conditions as necessary of a secure electrical information processing system's planned operational installation and utilization in a ship. The SLBTS's for ship programs fall into two types:

- a. Development SLBTS used for development and operational test and evaluation of system hardware, software, and their integration.
- b. Production SLBTS used for the interface testing and grooming of each suite of production hardware prior to shipboard installation.

(U) 40. GENERAL REQUIREMENTS

(U) 40.1 Electrical and physical perimeter barriers. The SLBTS housing the secure electrical information processing system shall establish an electrical perimeter barrier so as to preclude the detection of CE outside the established physical perimeter barrier.

(U) 40.2 Ship land based test site building. Any reference to metallic hull surface ships and new construction ships in the basic document shall be understood to refer to the SLBTS building structure.

(U) 40.3 Grounds. A ground bus shall extend through the SLBTS to the extent required for detailed bonding requirements. The ground bus shall be connected to the structural ground. The structural ground is assumed to have a grounding electrode to a continuous metallic underground water system or to an appropriate buried metal ground point.

(U) 50. DETAILED REQUIREMENTS

(U) 50.1 General. The detailed requirements for an SLBTS shall be in accordance with section 5, except as specified herein.

* (U) 50.2 Approved cables. Requirement 5.2.11 is modified so that RED cables having special characteristics (for example,

UNCLASSIFIED

MIL-STD-1680C(SH)
17 March 1993

APPENDIX E

COMBAT SYSTEM SHIP LAND BASED TEST SITE (Continued)

(U) double shielding) that do not meet the requirements of MIL-C-17, MIL-C-915, MIL-C-24640 or MIL-C-24643 shall be submitted to NAVSEA (Code 06K222) with full design characteristics prior to installation.

(U) 50.3 Normal access doors. Modify 5.3.1.3.a. to specify standard building doors rather than the metal joiner door.

(U) 60. STATUS, INSPECTION AND REPORTS

(U) 60.1 Ship land based test site status. The communication operational status of an SLBTS will be determined by the installed system configuration, and the degree to which the complete criteria specified herein are met.

(U) 60.1.1 National policy certification. NP certification is derived from an instrumented TEMPEST survey of an SLBTS. The need for an instrumented TEMPEST survey will be determined by the Commander, Naval Security Group Command on a case-by-base assessment basis.

(U) 60.1.2 Acceptable risk. Acceptable risk is the designation applied to indicate that a TEMPEST vulnerability assessment has been made and it has been determined that an instrumented TEMPEST survey is not warranted. The SLBTS's are designated in the acceptable risk category when the overall TEMPEST posture for an SLBTS has not been determined by instrumented TEMPEST survey. Operational limitations are imposed by OPNAV Instruction C5510.93 on all SLBTS's operating in an acceptable risk category.

(U) 60.1.3 Development SLBTS system configuration change. Any addition, deletion or modification to a development (see 5.2.11) SLBTS secure electrical information processing system shall be reported by letter or message to NAVSEA (Code 06K222) prior to resuming the processing of classified information. Where feasible, the report should enclose sketches or drawings of the before-and-after configuration of the equipment or wiring, or both. The necessity for an inspection of the change(s) will be determined on a case-by-case assessment.

(U) 60.1.4 Production SLBTS system configuration change. Any addition, deletion or modification to a production (see 5.2.11) SLBTS secure electrical information processing system shall be immediately followed with inspection by a certified FTA.

UNCLASSIFIED

MIL-STD-1680C(SH)
17 March 1993

APPENDIX E

COMBAT SYSTEM SHIP LAND BASED TEST SITE (Continued)

(U) 60.1.5 Operational limitations. Based on the reports of the inspections noted in 60.1.3 and 60.1.4, the CNO will continue in force the SLBTS NP certification or, when discrepancies are (U) reported, may void the NP certification and assign the SLBTS to the acceptable risk category with or without additional operational limitations. For an SLBTS operating in an acceptable risk category, the CNO will continue the SLBTS designation as an acceptable risk or, when discrepancies are reported, may cancel the acceptable risk designation and impose additional operational limitations until corrective action is taken.

(U) 60.1.6 Visual TEMPEST configuration control inspection. The VTCCI is composed of two parts. The first part is a visual TEMPEST inspection to determine compliance or noncompliance of the system being inspected with the system installation criteria contained in this standard. The second part of a VTCCI is plan and elevation diagrams of the information processing system to be used in a configuration control program. A VTCCI is required for all SLBTS that have a secure electrical information processing system installed. The initial VTCCI for each SLBTS shall normally be conducted upon completion of the secure electrical information processing system installation. The most recent VTCCI report and amendments thereto shall be retained by the SLBTS and shall reflect the existing configuration and all installation discrepancies that may exist. The VTCCI may be amended as specified in 60.1.7.

(U) 60.1.6.1 Visual TEMPEST inspection. A VTI is conducted as a part of a VTCCI and in accordance with 60.2.

* (U) 60.1.6.2 Configuration control plan and elevation view diagrams. The configuration control plan and elevation view diagrams shall identify, by equipment type and relative location, all equipment of the secure electrical information processing system installed within the electrical perimeter barrier of the secure processing center(s) and shall include relative location and electrical configuration of all signal and power transfer panels and switching units. Equipment in the secure electrical information processing system installed outside the secure processing center(s) need only be identified in the VTCCI by equipment type and space location.

* (U) 60.1.7 Partial TEMPEST inspection. Partial TEMPEST inspections are conducted to verify that previously reported configuration control discrepancies have been properly corrected

UNCLASSIFIED

MIL-STD-1680C(SH)
17 March 1993

APPENDIX E

COMBAT SYSTEM SHIP LAND BASED TEST SITE (Continued)

(U) or to identify installation deficiencies that may exist in an approved addition, deletion or modification to the secure electrical information processing system. The report of a partial TEMPEST configuration control inspection amends the most recent report of inspection of the complete secure electrical information processing system.

- * (U) 60.1.8 Single system. A SLBTS has one secure electrical information processing system (SEIPS) regardless of the number of classified information processing systems (CLIPS). An NP certification or acceptable risk category designation applies to the total SLBTS system.

(U) 60.2 Inspections.

(U) 60.2.1 Processing classified information. Classified information shall not be processed in a CLIPS until a VTCCI has been completed on that CLIPS and reported as specified herein.

(U) 60.2.2 Inspection of work. The SLBTS is responsible for acquiring an FTA inspection when the basic installation is complete, and when alterations or modifications are performed to the existing configuration of the secure processing system, except as specified in 60.1.3. Inspections for conformance with the criteria specified herein are considered part of the installation and are chargeable to the same contract or project order. Only the system or subsystem which has been installed, altered or modified need be inspected; however, any discrepancies observed by the inspector shall be reported. The installing activity is responsible for correction of all discrepancies attributable to installation. The SLBTS is also responsible for acquiring the services of an FTA visual TEMPEST inspector to inspect the corrected discrepancies and have an amending report submitted by the FTA. The report of a partial inspection shall be an amendment to the initial complete inspection report and, if applicable, shall include an amendment to the plan and elevation drawings.

(U) 60.2.3 Priority correction of discrepancies. Appendix F, (see 50.1) sets a priority for the correction of discrepancies noted in an FTA inspection of a ship. Such priorities are not valid for a SLBTS. Discrepancies in any CLIPS within a SLBTS shall be corrected prior to processing classified information in that CLIPS.

UNCLASSIFIED

MIL-STD-1680C(SH)
17 March 1993

APPENDIX E

COMBAT SYSTEM SHIP LAND BASED TEST SITE (Continued)

(U) 60.2.4 Inspection checkoff sheets. Inspection checkoff sheets will not be enclosed as part of the inspection report. The FTA inspection activities shall use the inspection checkoff sheets of Appendix F (see 50.3) when conducting the inspection, and in the preparation of the inspection report as an aid in identifying:

- a. Non-inspection items;
- b. The various elements of each detailed requirement to be inspected;
- c. As a work sheet in the preparation of the narrative inspection report for identifying the discrepancies by system, space, equipment, and quantity.

(U) 60.2.5 Configuration control programs. The VTCCI report will establish the basic reference data for a configuration control program. Inspections conducted subsequent to the initial VTCCI will be reported as amendments to the VTCCI. The information processing system configuration plan and elevation drawings shall be the basis for determining if alterations or modifications have been made to the system, and in turn, if such changes are in accordance with the installation criteria of this standard. When alterations or modifications have been accomplished, the resulting inspection need reflect only that portion of the system that has been changed.

(U) 60.2.6 Briefing of SLBTS representatives. Upon arrival for an inspection, the FTA will brief the cognizant management and supervisory personnel of the SLBTS being inspected on the purpose of the inspection, the general conduct of the inspection, and of any assistance required. Upon completion of the inspection, the FTA will inform the cognizant personnel of the general nature of any discrepancies.

(U) 60.3 Reports of visual TEMPEST configuration control inspections. Compliance with the NP on control of compromising emanations can only be guaranteed by an instrumented TEMPEST survey(ITS). The SPAWAR relies upon the report of the visual TEMPEST configuration control inspection to support the Navy's TEMPEST program. The narrative inspection report shall reflect compliance or noncompliance with this standard in sufficient detail to permit realistic appraisal without further inquire. Further, plan and elevation view diagrams will establish a

UNCLASSIFIED

MIL-STD-1680C(SH)
17 March 1993

APPENDIX E

COMBAT SYSTEM SHIP LAND BASED TEST SITE (Continued)

(U) baseline configuration for the secure electrical information processing system and shall be used as a future inspection item to ensure unauthorized changes are not made to the system. The VTCCI report will identify the FTA inspector by name, FTA card number and FTA card expiration date.

- a. Inspection reports shall be in the sample format provided in Appendix G and as a minimum, include the following:
 - (1) Each discrepancy shall be sufficiently identified to indicate the system, segment of a system, subsystem, equipment, cable, bond, space, quantity, or any data to reflect the gravity of the discrepancy.
 - (2) Identification of the type (development or production) of SLBTS.
 - (3) A summary of changes to the information processing system configuration by system or equipment shall be included.
 - (4) A statement as to whether the inspection covered by specific subsystems or a specific area, or covered the entire secure electrical processing system.
 - (5) The method of keying and signaling shall be identified so as to indicate the use of low level or high level, send and receive, in each part of the RED electrical processing system. The signal distribution method (baseband video or modulated carrier) of RED CCTV systems shall be identified.
 - (6) An identification of the electrical and physical perimeter barriers of the secure processing center by location and type. Electrical perimeter barrier location should specify the rooms by name or function enclosed within the barrier. Physical perimeter barrier location should be identified as the skin of the building, a fence (with distance to building), or other outline description. The type of barrier should be identified as fence, metallic, concrete, wood, dry wall or other substance. Or, a reference may be made to a key plan view in the configuration control diagram enclosure which contains equivalent information.
 - (7) A notation that discrepancies must be corrected prior to processing classified information in the secure processing system.

UNCLASSIFIED

MIL-STD-1680C(SH)
17 March 1993

APPENDIX E

COMBAT SYSTEM SHIP LAND BASED TEST SITE (Continued)

- (U) (8) Identification of RED fiber optic communication systems.
 - (9) As applicable, identification of specific physical security deficiencies of spaces containing any part of a RED electrical processing system.
 - (10) Identification of spaces designated as a secure processing center, secure remote area, remote area, exposed remote station, secure video control space and secure video viewing space.
 - (11) As an enclosure, a letter to be completed by the SLBTS to verify the accuracy of the plan and elevation diagrams or to report dissimilarities. This SLBTS-completed letter shall be forwarded to Commander, Naval Sea Systems Command (Ship Acquisition Project Manager) with a copy to NAVSEA (Code 06K222) and the FTA inspection activity.
- b. Inspection reports shall be distributed as follows:
Program Manager (original)
Commander, Naval Sea Systems Command (applicable Ship Acquisition Project Manager)
Commander, Naval Sea Systems Command (Code 06K222)
Commander, Naval Investigative Service Command (Code 26T)
- c. Commander, Naval Sea Systems Command, will serve as a central depository for VTCCI reports and will provide copies of such reports for subsequent inspections or surveys. Each report will be retained in this depository for a period of 5 years.

UNCLASSIFIED

MIL-STD-1680C(SH)
17 March 1993

APPENDIX F

INSPECTION CHECK-OFF SHEETS

(U) 10. SCOPE

(U) 10.1 Scope. This appendix covers inspection check-off sheets which shall be used in conducting complete visual TEMPEST configuration control and partial TEMPEST inspections.

(U) 20. APPLICABLE DOCUMENTS

(U) 20.1 See basic document or appropriate appendix.

(U) 30. DEFINITIONS

(U) 30.1 This section is not applicable to this Appendix.

(U) 40. GENERAL REQUIREMENTS

(U) 40.1 General. Inspection check-off sheets shall be used as an aid in conducting a VTCCI or partial TEMPEST inspection and may be reproduced locally as required. The priority designator for the correction of each discrepancy, and where required, the applicability of each criteria to the system being inspected, is suffixed to each listing.

(U) 50. DETAILED REQUIREMENTS

(U) 50.1 Correction of discrepancies. The FTA inspector shall note on the inspection report the relative priority assigned for the correction of a discrepancy. These priorities are noted for each requirement with a legend as follows:

- a. Pri 1 - The discrepancy should be corrected immediately.
- b. Pri 2 - The discrepancy should be corrected prior to or during the next scheduled availability.
- c. Pri 3 - The discrepancy should be corrected prior to or during the next overhaul.
- d. Pri CCA - The assignment of a correction priority will be on a case-by-case assessment based on the detailed description of the discrepancy in the FTA inspection report.

UNCLASSIFIED

MIL-STD-1680C(SH)
17 March 1993

APPENDIX F

INSPECTION CHECK-OFF SHEETS

(U) The case-by-case assessment, when required, will be made by the appropriate technical command in cooperation with the type commander. For a realistic assessment to be made, it is imperative that the FTA inspector provide every detail concerning a CCA discrepancy, such as identification of equipment, system subsystem, cables, cable route, cable length, use of armor instead of shield, and any other information that may assist in determining the potential threat of the situation.

(U) 50.2 Past installations. The installation criteria for shipboard secure electrical information processing systems has necessarily changed over the years. Many ships may have system installations accomplished prior to the implementation of any secure criteria. Discrepancies, by today's standards, may exist because of original cable or equipment installation which would require extensive retrofit to correct. As there is no intent to retrofit these items, they should not be reported as discrepancies. New requirements have been added in this revision of the standard which do not require retrofit for that item, for an installation accomplished prior to the effective date of this revision. The FTA inspector should not list that item as a discrepancy. The inspection check-off entry for a requirement in the above categories is identified by an explanatory note. The explanatory note(s) will indicate any exceptions for a specific item or for installations that were accomplished prior to this revision.

(U) 50.3 Use of inspection check-off sheets. The CNO assesses a ship TEMPEST posture and, if required, imposes operational limitations based in part on the FTA TEMPEST inspection reports. The final inspection report shall reflect the significance of the discrepancy(ies) in light of the total ship installation. For example, in reporting a specified number of discrepancies in the bonding of resilient mounted equipment to ground, the significance of the discrepancy can be better appraised when the estimated total number of resilient mounted equipment in the space is known. Therefore, the check-off sheets should note the quantity and location of discrepancies and the estimated total quantities of an item when applicable. In addition, sufficient data should be recorded to identify the system, segment of a system, subsystem, equipment, cable, space, bond, and any other data for inclusion in the narrative inspection report. The FTA inspection activities shall use the inspection check-off sheets in conducting the inspection, and in the preparation of the inspection report as an aid in identifying:

UNCLASSIFIED

MIL-STD-1680C(SH)
17 March 1993

APPENDIX F

INSPECTION CHECK-OFF SHEETS - Continued

- (U) a. non-inspection items;
- b. the various elements of each detailed requirement to be inspected;
- c. the applicability of each requirement to the ship being inspected;
- d. As a work sheet in the preparation of the narrative inspection report in identifying the discrepancies by system, space, equipment, and quantity.
- e. The assignment of a priority for the correction of a specific discrepancy, or to note the need for a more detailed description of the discrepancy for a case-by-case assessment by the appropriate technical command.

Inspection check-off sheets will not be enclosed as part of the inspection report.

- * (U) 50.4 Classification. The inspection check-off sheets specified herein are unclassified when not filled in, and may be reproduced locally. When discrepancy data and the ship name or hull number are entered, classify in accordance with 6.5.3.

UNCLASSIFIED

MIL-STD-1680C(SH)
17 March 1993

APPENDIX F

INSPECTION CHECK-OFF SHEETS - Continued

(U) 50.5 Detailed requirement and discrepancy data

(U) 5.1.1 RED and BLACK signal and control line interfaces.

Equipment having a RED and BLACK signal and control line interface is an equipment which has one or more connection(s) to a RED system (RED signal lines or RED control lines, or both) and one or more connection(s) to a BLACK system (BLACK signal lines or BLACK control lines, or both). In a p/c secure voice application, any equipment having two or more p/c secure voice signal (transmit and receive) inputs or outputs is a RED and BLACK signal and control line interface. An equipment having a RED and BLACK signal and control line interface shall be limited to the following categories:

- a. Isolation devices (see 3.25) having SPAWAR TEMPEST-approval. Appendix D, (see 50.2), includes equipment in this category, Pri-1.

- b. Isolation devices (see 3.25) not having SPAWAR TEMPEST-approval but have only low level signal and control interfaces. Requirements for these devices are in Appendix D, 40.1.c. Pri-1

UNCLASSIFIED

MIL-STD-1680C(SH)

17 March 1993

APPENDIX F

INSPECTION CHECK-OFF SHEETS - Continued

- (U) c. Cryptographic equipment, as an NSA-approved item, does not require SPAWAR TEMPEST-approval. See 5.1.7 for constraints in the use of clock to cryptographic equipment. Pri-1.
- * d. Processing equipment shared between RED and BLACK signal distribution systems shall have the distribution systems isolated from each other with a SPAWAR TEMPEST-approved isolation device listed in paragraph 50.2 of Appendix D. (for example, SA-734/SG, SA-2371/SG, SA-2626/BR, SB-1299/USQ-20 and SB-3372-US). Pri-1.
- e. Equipment in a. or c., installed for the purpose of technical or operational evaluation or both, do not require prior SPAWAR TEMPEST-approval for the period of the evaluation. Pri-1.
- f. RED processing equipment may receive signal or control information directly from a BLACK navigation system (for example, own ship speed, own ship head, roll, pitch, omega, loran, satellite and wind direction and speed).

UNCLASSIFIED

MIL-STD-1680C(SH)
17 March 1993

APPENDIX F

INSPECTION CHECK-OFF SHEETS - Continued

- (U) g. RED processing equipment may directly interface a time-code generator or display system. Frequency standard distribution systems shall only interface a RED system via a time-code generator or display system or via a SPAWAR TEMPEST-approved isolation device. Pri-1.
- h. RED processing equipment may directly interface a BLACK AN/SLA-10() Blanker-Video Mixer Group.
- i. Junction boxes installed as specified in 5.1.9.1. Pri-1.

* NOTE: The SA-734/SG switch box modified for low level operation with Field Change #1 as promulgated by Electronic Information Bulletin No. 838 may be used if the SA-2371/SG is not available.

UNCLASSIFIED

MIL-STD-1680C(SH)

17 March 1993

APPENDIX F

INSPECTION CHECK-OFF SHEETS - Continued

(U) 5.1.2.1 RED primary power. RED primary power shall be derived from power line filters. Such filters may be used to serve a multiple number of equipments or a single equipment. RED power for equipment at a remote operating position shall be obtained from a filtered source located at the remote area or extended from the secure processing center. The following systems and equipment shall be connected to RED primary power:

a. RED electrical processing equipment that is not SPAWAR TEMPEST-approved and has one or more RED high level signal or control interfaces. Pri-2.

* b. RED low level electrical processing equipment that requires RED power as a result of TEMPEST testing. These equipments are listed in Appendix D, 50.4. Pri-1.

* c. RED low level processing equipment that is not listed in Appendix D, Sections 50.1, 50.2, or 50.3 shall be installed on RED power unless approval for connection to BLACK power is given by NAVSEA (Code 03K222). Pri-1.

UNCLASSIFIED

MIL-STD-1680C(SH)
17 March 1993

APPENDIX F

INSPECTION CHECK-OFF SHEETS - Continued

(U) 5.1.2.2 BLACK primary power. The following systems and equipment shall be connected to BLACK primary power:

- a. BLACK electrical processing equipment. Pri-1.

- b. Cryptographic equipment. Pri-3.

- c. RED SPAWAR TEMPEST-approved equipment and systems. Pri-CCA.

- d. RED electrical processing equipment that is not SPAWAR TEMPEST-approved, but has only low level signal and control interfaces. Requirements for these equipments are in Appendix D, 40.1.c. Pri-3.

* NOTE: When making an installation in accordance with this paragraph, the non-SPAWAR TEMPEST-approved equipment shall not be connected to the same power panel as receivers and transmitters. Prior to 1983 the installation criteria required RED low level electrical processing equipment that was not SPAWAR TEMPEST-approved be connected to RED primary power; such items shall not be reported as a discrepancy if installed under the previous standard.

UNCLASSIFIED

MIL-STD-1680C(SH)

17 March 1993

APPENDIX F

INSPECTION CHECK-OFF SHEETS - Continued

(U) 5.1.2.3 Individual power line filters. An individual power line filter, installed adjacent to the equipment, shall be used to provide power to electrical processing equipment that is shared between the RED high level and BLACK electrical signal distribution systems. These filters shall be supplied from BLACK primary power. The filter shall not be used to supply power to any other equipment except an associated ID-866/SG Indicator Light (see 5.2.3). Pri-2.

- * (U) 5.1.2.4 Power filters. Power filters shall provide 100 dB of attenuation within the stopband of 14 kHz to 1 GHz. Filters shall meet this requirement as tested in accordance with MIL-STD-220 or as indicated by vendor specifications. NOTE: Filters previously installed are assumed acceptable at time of installation. Pri-3.

UNCLASSIFIED

MIL-STD-1680C(SH)
17 March 1993

APPENDIX F

INSPECTION CHECK-OFF SHEETS - Continued

(U) Filters shall be installed in each leg of the power circuit. The ampere rating of the filter shall be greater than the total connected load. The RED power may be derived from power line filters serving a multiple number of equipments, or from an individual power line filter serving a single equipment, except as otherwise specified herein. Individual power line filters should be installed as close as practical to the equipment requiring RED power to minimize RED cable length. Power line filters supplying a multiple number of equipments via a power distribution panel shall be installed within the secure processing center, secure remote area or remote areas. The RED power filters shall derive power from an unfiltered BLACK power source. Pri-3.

NOTE: Prior to 1979, the installation criteria allowed the filter location outside the space if the cable from the filter to the point of cable penetration is in conduit; such items shall not be reported as a discrepancy if installed under the previous standard.

(U) Filter discharge units installed with power line filters as a personnel safety device have no TEMPEST-related security significance, and are acceptable.

UNCLASSIFIED

MIL-STD-1680C(SH)
17 March 1993

APPENDIX F

INSPECTION CHECK-OFF SHEETS - Continued

(U) 5.1.3 Battery. The RED battery shall be separate and independent of the BLACK battery. Solid state rectifier power supplies shall be used for RED battery in lieu of power supplies using mercury vapor rectifiers or gas-filled regulator tubes. Pri-1.

- * (U) 5.1.4 Rotary or tone/pulse dial analog telephone installations in a secure processing center. In surface ships, rotary or tone/pulse dial analog telephones having a shore-tie capability, installed within the electrical perimeter barrier of a secure processing center, shall have their lines filtered. (Digital telephones, the STU-III, AN/STC-1 and AN/STC-2 for example, if installed within the EPB of a ship with a RED high level signal distribution system, shall have their signal lines shielded but not filtered.) Filter installations shall comply with the following:
- a. Filter characteristics and installation shall be in accordance with the following:
 - (1) Telephone line filters shall provide 100 dB of attenuation within the stopband of 14 kHz to 1 GHz, as tested in accordance with MIL-STD-220 or as indicated by vendor specifications. NOTE: Filter previously installed are assumed acceptable at time of installation. Pri-2.

UNCLASSIFIED

MIL-STD-1680C(SH)
17 March 1993

APPENDIX F

INSPECTION CHECK-OFF SHEETS - Continued

- (U) (2) Filters with exposed terminals shall be enclosed within a metal container. Pri-3.
- (3) The filters shall be installed within the center at the point of cable penetration; the external cable shall be brought through the electrical perimeter barrier directly into the filter. Pri-3.
- (4) For nonmetallic hull ships, filters shall be located for installation convenience within the center. Pri-3.
- (U) b. In a center having a RED high level signal distribution system, all conductors from the telephone passing through the perimeter shall be filtered; selection of filters shall provide continuity for both ringing and transmission circuits, if required. Pri-1.

UNCLASSIFIED

MIL-STD-1680C(SH)

17 March 1993

APPENDIX F

INSPECTION CHECK-OFF SHEETS - Continued

(U) c. In a center having a RED low level signal distribution system, only the voice signal line need be filtered. Pri-1.

* NOTE: Prior to 1979, the installation criteria allowed the filter to be located outside the space, if the cable from the filter to the point of cable penetration was in conduit; such items shall not be reported as a discrepancy if installed under the previous standard.

* (U) 5.1.4.1 Location of rotary or tone/pulse dial analog telephones with a shore-tie capability. In surface ships, the cradle for rotary or tone/pulse dial analog telephones having the capability of connection to a shore-tie shall be located a minimum of 3 feet from low level and 6 feet from high level RED processing equipment (except for remote units of a secure voice system) in secure remote areas. If required separation cannot be achieved, a filter, in compliance with paragraph 5.1.4.a., (1) and (2) shall be installed in a convenient location a minimum of 6 feet from the RED processing equipment. Telephones with audio-to-digital conversion, such as the STUI III, the AN/STC-2() or its commercial equivalent which have a shore-tie capability, whose cables are run within 6 feet of RED high level processing equipment, shall have their cables shielded, but do not require a filter or separation from RED processing equipment. Pri-1.

NOTE: Prior to 1983, a 2 foot separation was required and shall not be reported as a discrepancy if installed under previous criteria.

This requirement is not applicable to submarines.

UNCLASSIFIED

MIL-STD-1680C(SH)
17 March 1993

APPENDIX F

INSPECTION CHECK-OFF SHEETS - Continued

(U) 5.1.5 Landline terminations for surface ships. The landline termination shall be installed and terminated as shown on Drawing 803-44535868, Figures 1 and 2 of Appendix I, and as follows:

- * a. The following filter units, or NAVSEA approved fiber optic isolators, shall be installed in the teletype landlines: Pri-2.
 - Audio/tone circuits: F-1032/SG Radio Interference Filter.
 - D.C. circuits: F-1033/SG Filter Isolation Assembly.

- b. The case of the filter units shall be bonded to ground (see 5.2.14.14). Pri-1.

UNCLASSIFIED

MIL-STD-1680C(SH)
17 March 1993

APPENDIX F

INSPECTION CHECK-OFF SHEETS - Continued

- (U) c. Where the filter units are connected to switchboards or communication patching panels within the electrical perimeter barrier, the filters shall be mounted at the point of cable penetration on the outer side of the electrical perimeter barrier of the secure processing center. Where the filter units are connected to switchboards or communication patching panels outside of the electrical perimeter barrier, the filters shall be mounted, for installation convenience, outside the electrical perimeter barrier, but on or within the physical perimeter barrier of the secure processing center. Pri-1.

NOTE: Prior to 1976, the installation criteria required only that the filter be installed within the interior of the ship; such items shall not be reported as a discrepancy if installed under the previous standard.

(U) 5.1.6 Parallel data. Processing equipment and systems that have a data input or output in a parallel data format are classified in two categories:

- a. Equipment which form the core of the NTDS. Equipment in this category includes the AN/UYK-7(V), AN/SYA-4(V), AN/UYA-1(V), AN/UYA-4(V) and CP-642()/UYK. These equipments or systems shall be in compliance with 5.1.6.2.

UNCLASSIFIED

MIL-STD-1680C(SH)
17 March 1993

APPENDIX F

INSPECTION CHECK-OFF SHEETS - Continued

- (U) b. Equipment not identified in a. above, and which exchange data with the NTDS, directly interface the NTDS computer or are a part of or interface other processing systems. Equipment in this category includes but is not limited to the AN/SRD-19, AN/UYK-20(V), AN/UYQ-21(V) and AN/UYQ-23(V). These equipments or systems shall conform to the TEMPEST-related and physical security installation requirements specified herein.

NOTE: Not an FTA inspection item.

(U) 5.1.6.1 NTDS communication section. The NTDS communication section is considered to be that portion of NTDS which is processed in serial stream, including the serial-parallel converter equipment. The NTDS communication section (for example, Link 14) shall conform with the TEMPEST-related and physical security installation requirements specified herein (see Figure 3, Appendix I). Pri-3.

UNCLASSIFIED

MIL-STD-1680C(SH)
17 March 1993

APPENDIX F

INSPECTION CHECK-OFF SHEETS - Continued

(U) 5.1.6.2 NTDS parallel data section. Within the parallel data section of the NTDS (see Figure 3, Appendix I) the following shall be applied:

- a. The RED data section cables shall be considered RED low level cables for purposes of cable separation. Pri-1.

- b. Normal NTDS engineering practices of utilizing overall shielding and bonding shall be considered satisfactory as a minimum criteria. Pri-1.

- c. The TSEC/KG-40 shall be bonded to ground in accordance with 5.2.14.13.c and 5.2.14.13.g. Pri-1.

(U) 5.1.7 Isolation of clocking and control circuits. When common clocking or control (master clock, modem clock, timing control) is used to provide timing or control for both RED and BLACK processing equipment, these lines shall be decoupled by an approved isolation device. A RED processing equipment, listed in 50.2 Appendix D as a SPAWAR TEMPEST-approved RED/BLACK signal interface, is an approved isolation device. Certain equipment that is not SPAWAR TEMPEST-approved may be used as an isolation device subject to the requirements of 40.1.c. Appendix D. Pri-1.

UNCLASSIFIED

MIL-STD-1680C(SH)
17 March 1993

APPENDIX F

INSPECTION CHECK-OFF SHEETS - Continued

- * (U) 5.1.8.1 Common equipment cabinets. On surface ships, RED and BLACK processing equipment may be installed in the same electronic equipment cabinet or rack only if the original enclosures of both the RED and BLACK processing equipments have not been removed. On submarines, the RED and BLACK equipments may be installed in electronic cabinets or racks as required by space limitations.

Pri-1 if RED equipment is high level and the original equipment enclosures have been removed.

Pri-2 if RED equipment is low level.

- (U) 5.1.8.2 Relays and drivers. In nonmetallic hull surface ships, selector magnet drivers and other relay devices shall not be installed to make and break high level currents in the RED high level electrical signal distribution system, unless such devices are part of the cryptographic equipment. Pri-1.

- (U) In metallic hull surface ships, selector magnet drivers and isolation relays may be installed in the RED electrical signal distribution system if enclosed in a metal case, and the power, cable and bonding are in conformance with this standard. Pri-2.

UNCLASSIFIED

MIL-STD-1680C(SH)
17 March 1993

APPENDIX F

INSPECTION CHECK-OFF SHEETS - Continued

- * (U) 5.1.9 Cable-connecting enclosures. RED terminal boxes, junction boxes, power distribution panels and other cable-connecting enclosures shall maintain the integrity of the penetrating cable shield or armor with solid surface metal enclosures. This requirement is applicable to RED and BLACK cable-connecting enclosures within a secure processing center of a metallic hull surface ship having a RED high level signal distribution system. Pri-1: RED; Pri-2: BLACK

- * (U) 5.1.9.1 Shared junction boxes and cable entrance boxes. Junction boxes may be used as an intermediate connection point for cables containing both RED low level (for example, p/c secure voice or single audio system) and BLACK circuits. Cable entrance boxes containing both RED low level and BLACK circuits may be used for fanning cable conductors and their shields for an orderly penetration of a group of individual equipments (such as secure voice matrix switches). Cables and conductors of a shared junction box or cable entrance box shall conform to the following: Pri-1.

- * (U) a. The lay of a twisted pair shall be retained to the point of connection on the terminal strip.

UNCLASSIFIED

MIL-STD-1680C(SH)
17 March 1993

APPENDIX F

INSPECTION CHECK-OFF SHEETS - Continued

- * (U) b. The shield over a twisted pair shall be retained within the box to the point of connection on the terminal strip. The length of unshielded conductor at the point of termination shall be kept as short as practical. Where an existing box has existing cable shield(s) ended and bonded to ground at or near the point of cable entry, a sleeve-braid shield shall be place over the wire pair and bonded to ground at each end. If the twist has been removed from the wire pair, it shall be restored prior to replacing the shield.

- c. Within a junction box, the shield shall be bonded to ground at the terminal strip (see 5.2.14.19). Within a cable entrance box, the shield shall be bonded to ground at the equipment being served by the cable entrance box in accordance with the methods of 5.2.14.19.

- d. Conductors within a junction box shall be as short as possible yet be long enough to reach any terminal connection.

UNCLASSIFIED

MIL-STD-1680C(SH)
17 March 1993

APPENDIX F

INSPECTION CHECK-OFF SHEETS - Continued

(U) 5.1.10.1 BLACK shielded cable. BLACK cables serving and terminating within the electrical perimeter barrier of a secure processing center of a metallic hull surface ship having a RED high level electrical signal distribution system shall be shielded, except for lighting and receptacle cables connected to BLACK filtered power and telephone cables connected to perimeter-mounted filters. Pri-3.

NOTE: Prior to 1976, the installation criteria allowed the use of armored non-shielded cable in place of shielded cable; such items shall not be reported as discrepancy if installed under the previous standard.

* (U) 5.1.10.2 RED shielded cable. RED cables in all locations shall be shielded, except as permitted in Appendix J. This requirement is not applicable to RED fiber optic cables. Pri-1.

NOTE: Prior to 1976, the installation criteria allowed the use of armored non-shielded power cable in place of shielded cable; such items shall not be reported as discrepancy if installed under the previous standard.

* (U) 5.1.10.3 Large power cable exception. Primary a.c. power cables are exempted from the requirements of 5.1.10.1 and 5.1.10.2 where shielded cables of adequate current carrying capacity (generally greater than 15A) are not available in accordance with MIL-C-915, MIL-C-24640 or MIL-C-24643, in which case they shall be armored or contained in metal conduit or RF-tight flexible conduit. Pri-1: RED; Pri-3: BLACK.

UNCLASSIFIED

MIL-STD-1680C(SH)
17 March 1993

APPENDIX F

INSPECTION CHECK-OFF SHEETS - Continued

(U) 5.1.10.4 Secure voice cables. Cables and conductors serving secure voice processing equipment shall be isolated in the following manner: Pri-CCA.

- a. Transmit and receive audio lines shall be balanced twisted-pairs with each pair nonferrous shielded, and the shields insulated from each other. Where the transmit pair and associated transmit control wires are contained in one cable, an overall nonferrous shield may be used, provided the associated receive audio is contained in a separate twisted shielded pair cable.

- b. When a multi-circuit cable is used, each transmit and receive audio twisted-pair shall be non-ferrous shielded with all shields insulated, and with an overall insulating sheath.

(U) 5.1.10.5 Armored cable. There is no requirement for armored cable within this standard except as specified in 5.1.10.3. Armored cable, if used or terminated within the electrical perimeter barrier of a secure processing center of a metallic hull surface ship having a RED high level electrical signal distribution system, shall have the armor bonded to ground. The use of armored cable does not imply equivalence of armored and shielded cable.

NOTE: Not an FTA inspection item. Inspection requirements specified in 5.2.14.19 or 5.2.14.20.

UNCLASSIFIED

MIL-STD-1680C(SH)
17 March 1993

APPENDIX F

INSPECTION CHECK-OFF SHEETS - Continued

(U) 5.1.10.6 Cables not serving a secure processing center. New installation of cables, other than those terminating within the electrical perimeter barrier of a secure processing center, shall be routed around the electrical perimeter barrier, unless totally enclosed in RF-tight metal duct or conduit. The metal duct or conduit shall be bonded to ground at the points of penetration of the electrical perimeter barrier. This requirement is applicable only to a metallic hull surface ship having a RED high level electrical signal distribution system. Pri-3.

* NOTE: Prior to 1983 this was not a requirement under the criteria. Installations planned, designed or installed prior to that revision to the criteria shall not be reported as a discrepancy.

* (U) 5.1.10.7 Waveguide and rigid coaxial cables. New installations of waveguide and rigid coaxial cables that are not at ground potential at the points of penetration of the electrical perimeter barrier shall be routed around the electrical perimeter barrier of a secure processing center having a RED high level signal distribution system, unless totally enclosed within an RF-tight, solid-surface metallic trunk. Access plates, if required, shall maintain the shielding integrity of the trunk. The metallic trunk shall be bonded to ground at the points of penetration of the electrical perimeter barrier. Pri-3

NOTE: Prior to 1983 this was not a requirement under the criteria. Waveguide installations planned, designed or installed prior to that revision to the criteria shall not be reported as a discrepancy.

UNCLASSIFIED

MIL-STD-1680C(SH)
17 March 1993

APPENDIX F

INSPECTION CHECK-OFF SHEETS - Continued

- * (U) 5.1.10.8 Rotary or tone/pulse dial telephone line cables. Rotary or tone/pulse dial telephone line cables connected to telephones having a shore tie capability routed through, but not terminating within the electrical perimeter barrier of a secure processing center, shall be removed or enclosed in RF-tight metal duct or conduit which is bonded to ground at the points of penetration of the electrical perimeter barrier. This requirement is applicable only to a metallic hull surface ship having a RED high level electrical signal distribution system. Pri-2.

- * (U) 5.1.10.9 Cable splices. Splicing of RED cables shall maintain the electrical and physical properties of the cable. Splicing of RED cables outside of a secure processing center, secure remote area, or remote areas shall be avoided by using a single continuous cable run. Pri-1.

UNCLASSIFIED

MIL-STD-1680C(SH)
17 March 1993

APPENDIX F

INSPECTION CHECK-OFF SHEETS - Continued

(U) 5.1.10.10 Determination of RED high level and low level cables. Primary power cables serving equipment that processes RED high level signaling shall be considered as a RED high level cable for purposes of cable separation; other RED primary power cables that connect to the same power panel serving the above equipments shall also be considered as RED high level cables. RED primary power cables serving equipment requiring RED power and that processes only RED low level signaling shall be considered as RED low level cables for purposes of separation providing the source of the RED primary power (filter or power panel) is exclusively for equipment processing RED low level signaling, and has no RED primary power interconnection with RED equipment that processes RED high level signaling. RED signal and control cables that connect to RED low level signal input or outputs of RED electrical processing equipment, whether SPAWAR TEMPEST-approved or not, and to secure voice equipment shall be considered as RED low level system cables for purposes of cable separation. A cable containing an unbalanced analog or audio (voice) signal is a high level cable for purposes of cable separation. Other RED signal and control cables shall be considered as RED high level system cables for purposes of cable separation, with the following exceptions:

- a. The interconnecting cables supplied with the equipment between an electrical service assembly and a RED low level teletypewriter.
- * b. The signal line between an audio amplifier and a loudspeaker.
- * c. The interconnecting unbalanced audio cables between the SA-2216/U Audio Control and its associated audio distribution box and tape recorders.

NOTE: Inspected under 5.1.10.13 and 5.1.10.16. Prior to 1984 the installation criteria considered all RED power cables to be RED high level for purposes of cable separation. RED primary power cables serving equipment processing RED low level signaling that have been grouped with RED high level cables shall not be reported as a discrepancy if installed under the previous standard.

UNCLASSIFIED

MIL-STD-1680C(SH)
17 March 1993

APPENDIX F

INSPECTION CHECK-OFF SHEETS - Continued

(U) 5.1.10.11 RED cables external to the ship hull. RED high level system cables external to the ship hull shall be installed in conduit. The conduit shall be bonded to ground at the hull penetration points. Pri-1.

(U) 5.1.10.12 RED and BLACK conductor separation. Cables containing conductors connected to a RED high level electrical distribution system shall not contain conductors connected to a BLACK electrical distribution system. Pri-1.

(U) Cables containing conductors connected to a RED low level electrical distribution system may also contain conductors connected to a BLACK electrical distribution system providing that the RED conductors are shielded individually or overall from the BLACK conductors. Pri-1.

UNCLASSIFIED

MIL-STD-1680C(SH)
17 March 1993

APPENDIX F

INSPECTION CHECK-OFF SHEETS - Continued

(U) 5.1.10.14 Separation of RED and BLACK cables at crossover points. A crossover shall be made as near to 90 degree right angles as possible. Any crossover having an angle of less than 75 degrees shall be considered a parallel run.

NOTE: Inspected under 5.1.10.13, 5.1.10.14 and 5.1.10.15.

(U) 5.1.10.15 Separation of RED cables at crossover to other cables. On surface ships, a minimum separation between RED high level system cables and other cables at crossover points shall be: Pri-1.

a. 1 inch from shielded or armored cables containing BLACK, RED low level, or p/c secure voice signals.

b. 1 inch from unshielded or unarmored lighting cables connected to BLACK filtered power and telephone cables connected to perimeter-mounted filters.

UNCLASSIFIED

MIL-STD-1680C(SH)
17 March 1993

APPENDIX F

INSPECTION CHECK-OFF SHEETS - Continued

(U) c. 6 inches from BLACK unshielded or unarmored cables. No separation is required between RED low level, p/c secure voice and BLACK cables.

(U) 5.1.10.16 Cables shared between RED high level and BLACK electrical distribution systems. On surface ships, a cable shared between the RED high level and BLACK electrical distribution systems (for example, from an SA-734/SG Switch Box to a teletypewriter) shall be separated from all other cables as specified in 5.1.10.13 through 5.1.10.15. Pri-1.

(U) 5.1.10.17 Separation of RED and BLACK portable cables. Portable cables associated with items such as handsets, headsets, microphones or test equipment are excluded from the separation requirements of 5.1.10.13 through 5.1.10.16. The foregoing shall not be used to circumvent the separation requirements for "fixed" cable runs.

NOTE: Not an FTA inspection item. Inspected under 5.1.10.13 through 5.1.10.15.

UNCLASSIFIED

MIL-STD-1680C(SH)
17 March 1993

APPENDIX F

INSPECTION CHECK-OFF SHEETS - Continued

(U) 5.1.10.18 Conduit to alleviate cable separation requirements. That part of a cable enclosed in conduit is exempt from the cable separation requirements of 5.1.10.13 through 5.1.10.16. Separation shall be determined from the nearest exposed portion of RED cable. Conduit shall be bonded to ground at each end (see 5.2.14.23). Pri-CCA.

(U) 5.1.10.19 Conductive paths for signal and control lines. Within the EPB of an SPC having a RED high level electrical signal distribution system, RED signal and control lines, and BLACK signal and control lines, shall be composed of twisted pairs of conductors, and shall not use the shield, armor or the ship hull for the electrical return path. As an exception, the shield on coaxial cables shall be used as the electrical return path if required for system operation. On metallic hull surface ships with a RED high level electrical signal distribution system, submarines and nonmetallic hull ships, this requirement is applicable to the RED signal and control lines only. Pri-2.

UNCLASSIFIED

MIL-STD-1680C(SH)
17 March 1993

APPENDIX F

INSPECTION CHECK-OFF SHEETS - Continued

(U) 5.1.11.1 Objective. The overall secure voice system shall be accorded the standards for a p/c secure voice subsystem, unless otherwise specified herein. The secure voice system shall be isolated from all other systems as specified herein.

NOTE: Not an FTA inspection item. This is a design information item.

* (U) 5.1.11.2 Line and signal levels. The RED analog voice signal line shall be a 600-ohm balanced system. The audio level shall not exceed 0 dB as referred to 1 milliwatt (dBm), except in the signal line between an audio amplifier and a loudspeaker.

Not an FTA inspection item. This is a design information item.

(U) 5.1.11.3 Signal processing levels. When the secure voice system is capable of p/c operation, the RED signal level (see 5.1.11.2) shall not be greater than the BLACK signal level.

NOTE: Not an FTA inspection item. This is a design information item.

UNCLASSIFIED

MIL-STD-1680C(SH)
17 March 1993

APPENDIX F

INSPECTION CHECK-OFF SHEETS - Continued

(U) 5.1.11.4 Isolation between circuits. Secure voice system equipment, units, and parts shall offer a minimum of 80 dB isolation in the frequency range of 300 to 10,000 Hz between the circuit in which they are utilized and any transmit audio or control circuit on the ship.

NOTE: Not an FTA inspection item. This is a design information item.

* (U) 5.1.11.5 Plain/cipher secure voice signal line filters. The p/c secure voice send processing equipment (for example, TA-970()/U) that is within 6 feet of high level RED processing equipment and 3 feet of low level RED processing equipment shall have a signal line filter in the transmit signal line in a convenient location a minimum of 6 feet from RED processing equipment. The filter shall provide 100 dB of attenuation within the stopband of 14 kHz to 1 GHz. Pri-1.

(U) 5.1.11.6 Signal and control cables. Secure voice signal and control cables are considered the same as RED low level cables for the purpose of cable separation.

This requirement is not applicable to submarines.

NOTE: Inspected under 5.1.10.13 through 5.1.10.15.

UNCLASSIFIED

MIL-STD-1680C(SH)
17 March 1993

APPENDIX F

INSPECTION CHECK-OFF SHEETS - Continued

* (U) 5.1.11.7 Multichannel magnetic tape recorders in p/c secure voice. A multichannel magnetic tape recorder installed in a surface ship and used to record p/c secure voice communications channels shall:

* a. Use individually shielded twisted pair cables for audio input lines. Pri-1.

b. Be located not less than 6 feet from BLACK signal processors such as unfiltered radio telephones, modems, radio transmitters and switchboards. Pri-2.

(U) 5.1.12 Nonmetallic hull ship keying and signaling. See basic document. Pri-1.

UNCLASSIFIED

MIL-STD-1680C(SH)
17 March 1993

APPENDIX F

INSPECTION CHECK-OFF SHEETS - Continued

(U) 5.2.1 RED primary power distribution panel location. Fuse and primary a.c. power distribution panels serving RED electrical processing systems on surface ships shall be located within secure processing centers, secure remote areas or remote areas. Fuse and primary a.c. power distribution panels within: Pri-2.

a. Secure processing centers may provide power distribution to secure remote areas and remote areas.

b. Secure remote areas may provide power distribution to remote areas.

NOTE: Prior to 1976, the installation standard allowed the location of fuse and power panels to be located outside the secure processing center; such items shall not be reported as a discrepancy if installed under the previous standard.

UNCLASSIFIED

MIL-STD-1680C(SH)
17 March 1993

APPENDIX F

INSPECTION CHECK-OFF SHEETS - Continued

- * (U) 5.2.2 Equipment power connection. Processing equipment requiring RED power shall be permanently connected to a RED power source and shall not be connected to a lighting panel. BLACK equipment contained in electronic equipment cabinets or racks may employ the cabinet blower power switches or the open rack power strip switches as the equipment disconnect. If the number of equipment exceeds the number of blower or power strip switches, additional switches should be added. A common power cable from the distribution panel may serve several disconnect switches in the cabinet. Pri-2.

NOTE: Prior to 1979, the installation standard did not prohibit RED power to certain receptacles used for test equipment; such items shall not be reported as discrepancies if installed under the previous standard.

- * (U) 5.2.3 Primary a.c. power for ID-866/SG. The ID-866/SG Indicator Light, when used to show the status of a shared RED/BLACK processing equipment, shall derive primary a.c. power from the shared equipment to assure the ID-866/SG is energized when the shared equipment is energized. When used as a remote cut-out as specified in 5.3.5.1.1, the ID-866/SG may be connected to either RED or BLACK primary a.c. power or to the filtered power source which is connected to its associated send processor.

NOTE: Not an FTA inspection item. This is a design information item.

UNCLASSIFIED

MIL-STD-1680C(SH)
17 March 1993

APPENDIX F

INSPECTION CHECK-OFF SHEETS - Continued

- * (U) 5.2.4 Primary power to other facilities. Primary power for lighting and receptacles in the secure processing center shall be BLACK power and shall not be derived from an electronic equipment power distribution panel. (Note: BLACK power may also be BLACK "filtered" power.) Pri-3

NOTE: Prior to 1979, the installation standard did not prohibit RED power to certain receptacles used for test equipment; such items shall not be reported as discrepancies if installed under the previous standard.

- (U) 5.2.5 RED battery location. A RED common battery power source, if required, shall be located within the secure processing center. Pri-3.

- (U) 5.2.6 Approved equipment. Communication, electronic and ancillary equipment installed in a secure processing center shall be of a type included in approved NAVSEA drawings or documents. Pri-CCA.

UNCLASSIFIED

MIL-STD-1680C(SH)
17 March 1993

APPENDIX F

INSPECTION CHECK-OFF SHEETS - Continued

- * (U) 5.2.7 Cryptographic equipment modification. Modification of cryptographic equipment shall not be made without proper authority. Authorized modifications to a cryptographic equipment are promulgated as changes to the KAM Maintenance Manual for that equipment. Pri-1.

NOTE: Installation and installation-check out of cryptographic equipment shall only be accomplished by authorized personnel as indicated in OPNAVINST 2221.3.

(U) 5.2.8 Cryptographic equipment cables. The cables supplied with cryptographic equipment are often of specific length, wire gage or shielding characteristics, and are part of the total system design. The fully assembled cables shall not be modified or reduced in length, unless promulgated as an authorized change. Pri-2.

(U) 5.2.8.1 Electronic equipment cables. Some of the interconnecting cables supplied with SPAWAR TEMPEST-approved equipment may be unique in construction and design to enhance its TEMPEST characteristics. Such cables shall not be modified when the installation control drawings or technical manuals specify a prohibition against modification. Typical of cables in this category are the interconnecting cables between the ESA and the basic teletypewriter unit in low level teletype applications. Pri-1.

UNCLASSIFIED

MIL-STD-1680C(SH)
17 March 1993

APPENDIX F

INSPECTION CHECK-OFF SHEETS - Continued

(U) 5.2.9 Radio transmitting equipment. Radio transmitters and other devices used for the transmission of electromagnetic energy through space may be installed in or adjacent to a secure processing center. The foregoing allows the transmitter room to be installed adjacent to and to be entered from a secure processing center. In a ship having a RED high level electrical signal distribution system, it is recommended that the electrical perimeter barrier be established between the two spaces to preclude the necessity of applying the TEMPEST criteria (for example, cable type, shielding and bonding) of this standard in the transmitter room. The transmitter room, when so located, is contained within the physical perimeter barrier of the secure processing center.

NOTE: Not an FTA inspection item. This is a design information item.

(U) 5.2.10 Radio set controls. Radio set control units, or other devices providing remote control or indicator circuits (for example, C-1004/SG, C-9351/WSC-3) may be mounted on any RED or BLACK processing equipment, except as otherwise specified herein (see Appendix A, 50.1.3 and Appendix B, 50.1.5).

NOTE: Not an FTA inspection item. This is a design information item.

UNCLASSIFIED

MIL-STD-1680C(SH)
17 March 1993

APPENDIX F

INSPECTION CHECK-OFF SHEETS - Continued

- * (U) 5.2.11 Approved cables. Shielded cables shall meet the applicable requirements of MIL-C-17, MIL-C-915, MIL-C-24640, or MIL-C-24643. Pri-3.

NOTE: Non-military specification cables are acceptable in the AN/SLQ-32(V) and AN/SQQ-28(V).

- * (U) 5.2.11.1 Cable connecting hardware. Cable connecting hardware, such as stuffing tubes for RED equipment, junction boxes, power panels and terminal boxes within the electrical perimeter barrier of a secure processing center shall be of conductive material in surface ships having a RED high level electrical signal distribution system. This requirement is applicable to BLACK equipment, junction boxes, power panels and terminal boxes within the electrical perimeter barrier of a secure processing center of a surface ship having a RED high level electrical signal distribution system. Non-conductive cable connecting hardware, such as nylon or plastic, is acceptable for RED or BLACK equipment, junction boxes, terminal boxes and power panels in a ship having a RED low level electrical signal distribution system. Pri-2.

UNCLASSIFIED

MIL-STD-1680C(SH)
17 March 1993

APPENDIX F

INSPECTION CHECK-OFF SHEETS - Continued

- * (U) 5.2.12 Power panels, junction boxes and terminal boxes. Power panels and cable connecting containers (for example, junction boxes) shall be used to breakout RED cable conductors for splicing, connection or interconnection and shall have a solid surface metal construction. Containers with precut knockouts shall be avoided; however, they are acceptable if blocked with metallic snap-on buttons, brazed or otherwise secured. When cables are permanently removed from the container, the hole shall be blocked by any of the methods identified herein. This requirement is applicable to RED and BLACK containers within the electrical perimeter barrier of a secure processing center of a metallic hull surface ship having a RED high level electrical signal distribution system. Pri-1: RED; Pri-2: BLACK.

(U) 5.2.13 Cable hangers and supports. Common cable hangers and supports may be used for cable runs if the specified requirements are observed.

NOTE: Not an FTA inspection item. This is a design information item.

UNCLASSIFIED

MIL-STD-1680C(SH)
17 March 1993

APPENDIX F

INSPECTION CHECK-OFF SHEETS - Continued

- * (U) 5.2.14 Bonding methods. Within the electrical perimeter barrier of a secure processing center, for RED equipment and cable, and as specified in other areas, the various parts, units and assemblies of an electrical processing distribution system shall be bonded to ground as specified herein. General bonding requirements for electromagnetic compatibility (EMC) and safety shall comply with MIL-STD-1310 to the extent such requirements do not conflict with the requirements herein. One bonding method for each equipment may suffice as long as it meets the minimum bonding and grounding requirements of personnel safety, EMC and TEMPEST.

(U) In non-metallic hull ships, the third wire or safety ground shall be an acceptable substitute for any bond strap specified herein.

NOTE: Not an FTA inspection item. This is a design information item.

UNCLASSIFIED

MIL-STD-1680C(SH)
17 March 1993

APPENDIX F

INSPECTION CHECK-OFF SHEETS - Continued

(U) 5.2.14.1 Bonding classes. Bonding methods shall be of the following classes:

a. Class A. A bond achieved by joining two metallic items or surfaces through the process of welding or brazing.

* b. Class B. A bond inherent in the installation of an item or equipment by mounting hardware or other are of metal-to-metal contact.

c. Class C. A bond achieved by bridging two metal surfaces with a metallic bond strap.

NOTE: Not an FTA inspection item. Inspection req are specified in 5.2.14.2 through 5.2.14.2^f

UNCLASSIFIED

MIL-STD-1680C(SH)
17 March 1993

APPENDIX F

INSPECTION CHECK-OFF SHEETS - Continued

- * (U) 5.2.14.2 Class B bonds. When a class B bond is specified as the method of bonding an equipment, box or panel to ground, all available mounting holes provided in the equipment shall be used. The diameter of the mounting bolts, nuts, and washers shall conform to the mounting holes with normal tolerances. Mounting holes must be drilled, minimum diameter shall be for 0.25 inch hardware unless otherwise specified. Bolts, nuts and washers shall be zinc-plated steel or CRES Series 300. Paint, grease, lacquer, and other resistive materials shall be removed from the surface contact area(s) prior to bonding. Class 3 chemical coatings, i.e. anodizing applied in accordance with MIL-C-5541, are conductive coatings and shall not be removed. Abrasives used shall be of the type that produce a clean, smooth surface. The cleaned metal surfaces and threaded hardware shall be coated with an anti-seize compound conforming to MIL-T-22361 prior to mounting the equipment, except as specified in 5.2.14.17 and 5.2.14.18. Pri-2.

- * (U) 5.2.14.3 Flexible bond strap fabrication. Flexible bond strap shall be fabricated from 1-inch flat braided wire and lugs fabricated from 0.840-inch diameter copper tubing or commercial copper lug with a barrel large enough to accommodate the 1-inch braid without trimming. The length shall be as required and as short as practical. Drill mounting holes for 5/16-inch hardware with normal tolerances. Zinc plating or other protective coating is required on bond straps installed in topside areas and is allowed on bond straps installed in other areas to prolong the effective life of the strap and reduce galvanic action between dissimilar metals. Bolts, nuts, and washers shall be 5/16-inch minimum hardware and zinc plated or CRES Series 300; existing stocks of cadmium-plated hardware may be used until exhausted. See inset in Figure 4 of Appendix I for typical bond strap fabrication. Flexible bond straps will be used to bond resilient mounted equipment or cabinets (see 5.2.14.11) or slide-mounted equipment (see 5.2.14.12). Pri-2.

UNCLASSIFIED

MIL-STD-1680C(SH)
17 March 1993

APPENDIX F

INSPECTION CHECK-OFF SHEETS - Continued

- * (U) 5.2.14.4 Solid bond strap fabrication. Solid bond strap material shall be copper, at least 0.020-inch thick, and at least 3/4-inch wide. The length of the bond strap shall be not greater than five times the width and shall be as short as practical. Punch or cut out mounting holes for 5/16-inch minimum hardware with normal tolerances. Zinc plating or other protective coating is allowed on bond straps to prolong the effective life of the strap and reduce galvanic action between dissimilar metals. After installation, the bond strap may be painted to match the surrounding area. Bolts, nuts, and washers shall be 5/16-inch minimum hardware and zinc-plated steel or CRES Series 300. Pri-2.

- * (U) 5.2.14.5 Preparation for use of bond straps. Bond straps shall be installed in locations which permit rapid inspection and replacement. Bonds shall in no way interfere with internal parts of the equipment or the movement of resilient mounts. Ground studs built into enclosures shall be utilized in preference to drilling a new hole providing the ground stud location on the enclosure will not increase the length of the bond strap beyond normal tolerance. Pri-2.

UNCLASSIFIED

MIL-STD-1680C(SH)
17 March 1993

APPENDIX F

INSPECTION CHECK-OFF SHEETS - Continued

(U) Grease, paint, lacquer and other resistive materials shall be removed from at least 1-1/2 times the bonding surface contact area. Class 3 chemical coatings, i.e. anodizing applied in accordance with MIL-C-5541, are conductive coatings and shall not be removed. Abrasives used shall be of the type that produce a clean, smooth surface. The cleaned metallic surface and threaded hardware shall be coated with an antiseize compound, conforming to MIL-T-22361 prior to the installation of the bond strap.
Pri-1.

NOTE: Prior to 1984 the coating of all threaded hardware with antiseize compound was not a requirement under this criteria. Therefore, this requirement shall not be reported as a discrepancy in installations completed prior to the publication of MIL-STD-1680B (SH).

(U) 5.2.14.6 Assembled equipment units. Except where specific equipment bonding requirements are specified herein, assembled equipment (for example, AN/UGC-143 Navy Standard Teletypewriter (NST) Set) shall be considered to have all physical and electrical units properly bonded to each other based on the requirement of the applicable equipment specification. This includes hinged panels, retractable drawer assemblies, and other movable units or parts provided within an assembled equipment for ease of installation or maintenance.

NOTE: Not an FTA inspection item. Inspection requirements specified in 5.2.14.2 through 5.2.14.25.

UNCLASSIFIED

MIL-STD-1680C(SH)
17 March 1993

APPENDIX F

INSPECTION CHECK-OFF SHEETS - Continued

(U) 5.2.14.7 Fabricated equipment units. The main enclosure of fabricated equipment (for example, locally fabricated, engineered or installed console configurations) containing assembled equipment shall be bonded to ground with class A, B, or C bonds. Units shall be bonded to ground via the main enclosure with class A, B, or C bonds, as appropriate. Pri-2.

* (U) 5.2.14.8 Electronic equipment cabinets. Electronic equipment cabinets (for example CY-4516()/S) shall be bonded to ground with class A, B, or C bonds. Conductive Class 3 chemical coatings, i.e., anodizing, applied in accordance with MIL-C-5541 are conductive coatings and shall not be removed. Conductive paint applied in accordance with MIL-P-21035 and conductive caulk should be used when installing equipment racks, cabinets and consoles on their foundations with a Class B bond. Conductive paint applied in accordance with this paragraph shall be certified in writing at the time of application. A copy of this written certification shall be placed in the ship's TEMPEST file. This document shall certify: Pri-1.

- a. that the paint used meets the requirements of Military Specification MIL-P-21035.

UNCLASSIFIED

MIL-STD-1680C(SH)
17 March 1993

APPENDIX F

INSPECTION CHECK-OFF SHEETS - Continued

- (U)
- b. that the surface of the conductive material, i.e., metal, etc. to which the paint has been applied has been properly prepared and was completely free of all foreign material prior to application of the conductive paint.

 - c. that the paint was properly mixed by volume and applied with sufficient coats to insure conductivity as well as prevent corrosion.

 - d. that all attachment hardware fully meets the current requirements of this standard.

 - e. that, when tested for resistance between the secondary structure (rack, cabinet or console) and the primary structure (ship's hull), there will be a resistance of no more than 300 milliohms.

UNCLASSIFIED

MIL-STD-1680C(SH)
17 March 1993

APPENDIX F

INSPECTION CHECK-OFF SHEETS - Continued

- * (U) 5.2.14.9 Equipment mounted in electronic equipment cabinets. Equipment, except cryptographic equipment, rack-mounted in electronic equipment cabinets may be considered bonded to ground with the front-panel mounting hardware. Surface preparation shall be in accordance with 5.2.14.2, 5.2.14.5. Pri-1.

(U) 5.2.14.10 Bonding of non-resilient mounted equipment. Non-resilient mounted equipment in their original cabinets, except cryptographic equipment, shall be bonded to ground with a class B bond or class C bond strap. See 5.2.14.13 for bonding cryptographic equipment. Pri-2.

- * (U) 5.2.14.11 Bonding of resilient mounted equipment or cabinets. Resilient mounted equipment or cabinets shall be bonded to ground with a class C bond strap. Figures 5 and 6 of Appendix I illustrate typical and specific bonding methods for resilient mounted equipment. Flexible bond straps may be used on equipment having resilient mounts which allow multidirectional excursions that may damage solid class C bond straps. In submarines, the third wire or safety ground shall be an acceptable substitute for a bond strap. Pri-1.

UNCLASSIFIED

MIL-STD-1680C(SH)
17 March 1993

APPENDIX F

INSPECTION CHECK-OFF SHEETS - Continued

- * (U) 5.2.14.12 Bonding of equipment mounted on slide foundations. Equipment mounted on sliding foundations (for example, slide rack-mounted shelves) shall be bonded to the sliding foundations as specified for each category of equipment in 5.2.14.10, 5.2.14.11, and 5.2.14.13. A class B bond may be used to bond the sliding foundation to the solid foundation as specified in 5.2.14.9 if the slide is secured to the rack with hex-head bolts or standard slotted screws. If the slide is secured with fasteners meant to be tightened with fingers rather than tools, the slide foundation shall be class C bonded to the solid foundation by method A or B as shown in Figure 4, Appendix I. An alternate method to the above is to bond the equipment directly to the solid foundation with a solid or flexible class C bond strap, as appropriate. In submarines, the third wire or safety ground shall be an acceptable substitute for a bond strap. Pri-1.

- (U) 5.2.14.13 Bonding of cryptographic equipment. Cryptographic equipment and cryptographic ancillary units (for example, TSEC nomenclatured equipment) shall be bonded to ground with a class C bond strap, except as otherwise specified herein. Pri-1.

UNCLASSIFIED

MIL-STD-1680C(SH)
17 March 1993

APPENDIX F

INSPECTION CHECK-OFF SHEETS - Continued

(U) A new hole shall not be drilled in cryptographic equipment or cabinet enclosure, except where the equipment has a separate cable entry section. Existing mounting holes may be enlarged to accommodate standard mounting hardware. Pri-CCA.

The following are typical bonding arrangements for cryptographic equipment:

- a. TSEC/KG-30 Family. Install three mounting bolts with standard flat washers on each bolt between the foundation and the TSEC/KG-30 Family member (for example TSEC/KG-35, TSEC/KG-36, and TSEC/KG-38). Install the fourth mounting bolt with a flat washer and bond strap. The bond strap shall be against the equipment with the flat washer between the bond strap and the foundation. Secure the loose end of the bond strap to the foundation with 5/16-inch minimum hardware. An alternate method is to connect a bond strap between the case of the equipment cable entry section and the foundation.

- b. TSEC/KI-1. The designated mount, MT-4580/U or MT-4667/U, provides the necessary bond between the KIT-1(V)/TSEC and a foundation. The designated mount, MT-3950/U, MT-4580/U or MT-4667/U provides the necessary bond between the KIR-1(V)/TSEC and a foundation. The designated mounts shall be bonded to ground with a class B bond or a class C bond strap.

UNCLASSIFIED

MIL-STD-1680C(SH)
17 March 1993

APPENDIX F

INSPECTION CHECK-OFF SHEETS - Continued

(U) c. TSEC/KG-40 or TSEC/KG-40A. The designated mount, MT-4417/S, provides the necessary bond between the TSEC/KG-40 or 40A and a foundation. The designated mount shall be bonded to ground with a class B bond or class C bond strap installed between the ground stud provided on the mount and the foundation.

* d. TSEC/KG-44. The TSEC/KG-44 mounted in the OL-350/SMQ-11 has an inherent bond to ground and does not require additional bonding. The AN/SMQ-11() shall be bonded to ground with a class C bond strap.

* e. TSEC/KG-45. The TSEC/KG-45 mounted in the electronic equipment cabinet containing the OR-209/SRQ-4 has an inherent bond to ground, and does not require additional bonding.

* f. KGR-28/TSEC. The KGR-28/TSEC mounted in a KGF-28/TSEC mounting panel that is installed as part of the AN/SMQ-10, Meteorological Data Receiver-Recorder Set, has an inherent bond to ground, and does not require additional bonding.

UNCLASSIFIED

MIL-STD-1680C(SH)
17 March 1993

APPENDIX F

INSPECTION CHECK-OFF SHEETS - Continued

- * (U) g. KGX-40/TSEC. The KGX-40/TSEC shall be bonded to its mount with a class B bond. The mount shall be bonded to ground with a class B bond or class C bond strap.

- * h. TSEC/KY-58. The TSEC/KY-58 is bonded to the HYX-58/TSEC via the mechanical fasteners. The HYX-58/TSEC mounted in MT-4841(V)/U is bonded to the unit with internal copper fingered leaf springs, and does not require additional bonding.

- * i. TSEC/KY-75. The TSEC/KY-75 shall be bonded to ground with a solid class C bond strap attached to the front panel stud of the TSEC/KY-75 and the MT-4841/U electrical equipment mounting base. An additional flat washer shall be installed on the stud to ensure a tight bond.

- * (U) j. MT-4841(V)/U. Units mounted in MT-4841(V)/U (except the TSEC/KY-75 and AN/USC-43) have an inherent bond to the MT-4841(V)/U. The MT-4841(V)/U may be class B bonded if the rear mounting flanges are bolted to ground; otherwise, the MT-4841(V)U shall be bonded to ground with a class C solid bond strap.

UNCLASSIFIED

MIL-STD-1680C(SH)
17 March 1993

APPENDIX F

INSPECTION CHECK-OFF SHEETS - Continued

- * (U) k. TSEC/KG-59 and KOK-6. The TSEC/KG-59 and KOK-6 shall be bonded to ground with a class B bond or a class C bond solid strap.

- * 1. TSEC/KG-84. The standard TSEC/KG-84 installation using the MT-4841(V)/U Ship Shelf has an inherent class B bond to the MT-4841. The non-standard installation without the MT-4841 shall be class C bonded using the TSEC/KG-84 grounding plate kit.

- * m. TSEC/KGV-11. The TSEC/KGV-11 mounted in the TD-1271B/U, part of the OK-454(V)/WSC-3 or OK-455(V)/WSC, has an inherent bond to the electrical equipment cabinet. The electrical equipment cabinet shall be bonded to ground with a class B bond or a class C solid bond strap.

- * n. TSEC/KWR-46. The TSEC/KWR-46 has an inherent bond to the HNF-1/TSEC through the copper fingered leaf springs on the mount contacting the rear of the TSEC/KWR-46. The HNF-1/TSEC may be class B bonded if the rear mounting flanges are bolted to ground, otherwise, the HNF-1/TSEC shall be bonded to ground with a class C solid bond strap.

UNCLASSIFIED

MIL-STD-1680C(SH)
17 March 1993

APPENDIX F

INSPECTION CHECK-OFF SHEETS - Continued

- * (U) o. TSEC/KYV-5. The TSEC/KYV-5 has an inherent class B bond to the AN/USC-43(V) Basic Terminal Unit (BTU). The BTU shall be bonded to ground with a class C solid bond strap between the ground stud on the BTU and the foundation.

(U) 5.2.14.14 Bonding of isolation devices and filters. Isolation devices and telephone and signal lines filters shall be bonded to ground with class B bonds or class C bond straps. Power filters shall be bonded to ground with a class C bond strap. Pri-1.

(U) 5.2.14.15 Bonding of RED terminal boxes and power distribution panels or switch boxes. Terminal boxes, junction boxes, primary a.c. power distribution panels and switch boxes which are part of a RED electrical processing system shall be bonded to ground with a class B bond or class C bond strap. Pri-1.

UNCLASSIFIED

MIL-STD-1680C(SH)
17 March 1993

APPENDIX F

INSPECTION CHECK-OFF SHEETS - Continued

(U) 5.2.14.16 Bonding of BLACK terminal boxes and power distribution panels or switch boxes. Terminal boxes, junction boxes, primary a.c. power distribution panels and switch boxes which are part of a BLACK electrical processing system within the electrical perimeter barrier of a secure processing center shall be bonded to ground with a class B bond or class C bond strap. This requirement is only applicable to metallic hull surface ships having a RED high level electrical signal distribution system. Pri-2.

* (U) 5.2.14.17 Bonding of covers to RED terminal boxes and junction boxes. Metal-to-metal contact shall be established around the entire perimeter between the cover and box of terminal and junction boxes which are part of a RED electrical processing system. Pri-1.

* (U) 5.2.14.18 Bonding of covers to BLACK terminal boxes and junction boxes. Metal-to-metal contact shall be established around the entire perimeter between the cover and box of terminal and junction boxes which are part of a BLACK electrical processing system within the electrical perimeter barrier of a secure processing center of metallic hull surface ships having a RED high level electrical signal distribution system. Pri-2.

UNCLASSIFIED

MIL-STD-1680C(SH)
17 March 1993

APPENDIX F

INSPECTION CHECK-OFF SHEETS - Continued

(U) 5.2.14.19 Bonding of shields and armor on RED cable. RED cables shall have the shields (and armor, if applicable) of the cable bonded to ground at both ends of the cable in accordance with the following: Pri-1.

- a. Cable shields for low level circuits terminating on barrier terminal strips as specified in 5.1.9.1 shall be bonded to ground within the enclosure at the terminal strip.

- b. Cable shields for RED high level signaling circuits shall be bonded to ground at the point of entry to an enclosure.

- c. Cable shields not covered by a. and b. above shall be bonded to ground by any of the following:
 - (1) At a terminal strip within an enclosure.

 - (2) At the point of entry within an enclosure.

 - (3) Via a standard threaded cable plug connector that shall provide shield bonding via the connector hardware.

UNCLASSIFIED

MIL-STD-1680C(SH)
17 March 1993

APPENDIX F

INSPECTION CHECK-OFF SHEETS - Continued

- (U) d. Armor shall be bonded to ground at the point of entry to an enclosure.
- e. RED cables requiring an ungrounded shield at one end of the cable in conformance with manufacturer's specifications shall be approved by NAVSEA (Code 03K222) prior to installation.
- f. The methods of bonding shields and armor shall be in accordance with one or more of the following:
- (1) Figures 7 through 10, Appendix I.
 - (2) Any of the methods of MIL-STD-1310.
 - (3) Any of the methods in DOD-STD-2003 that provide for the bonding of shields or armor.
 - (4) The use of ground ring kits and connectors designed to provide shield bonding via the connector hardware, including coaxial and triaxial.

UNCLASSIFIED

MIL-STD-1680C(SH)
17 March 1993

APPENDIX F

INSPECTION CHECK-OFF SHEETS - Continued

- (U) (5) Other methods having prior approval of NAVSEA (Code 03K222) which will be based on submitted drawings or sketches illustrating the methods proposed.

NOTE: Identify any system with only one end of a cable shield bonded to ground in the inspection report.

(U) 5.2.14.20 Bonding of shields and armor on BLACK cables. In metallic hull surface ships having a RED high level signal distribution system, BLACK cables with shield or armor, within the electrical perimeter barrier of a secure processing center, shall have the shield(s) (and armor, if applicable) bonded to ground at both ends of the cable in accordance with the following: Pri-2.

a. Cable shields shall be bonded to ground by any of the following:

(1) At a terminal strip within an enclosure.

(2) At the point of entry within an enclosure.

* (3) Via a standard threaded cable plug connector that shall provide shield bonding via the connector hardware.

UNCLASSIFIED

MIL-STD-1680C(SH)
17 March 1993

APPENDIX F

INSPECTION CHECK-OFF SHEETS - Continued

- (U) b. Armor shall be bonded to ground at the point of entry to an enclosure.
- c. Cables requiring an ungrounded shield at one end of the cable in conformance with manufacturer's specifications shall be approved by NAVSEA (Code 03K222) prior to installation.
- d. The methods of bonding shields and armor shall be in accordance with one or more of the following:
- (1) Figures 7 through 10, Appendix I.
 - (2) Any of the methods of MIL-STD-1310.
 - (3) Any of the methods in DOD-STD-2003 that provide for the bonding of shields or armor.

UNCLASSIFIED

MIL-STD-1680C(SH)
17 March 1993

APPENDIX F

INSPECTION CHECK-OFF SHEETS - Continued

- (U) (4) The use of ground ring kits and connectors designed to provide shield bonding via the connector hardware, including coaxial and triaxial.
- (5) Other methods having prior approval of NAVSEA (Code 03K222) which will be based on submitted drawings or sketches illustrating the methods proposed.

NOTE: Identify in the inspection report any system with only one end of cable shield bonded to ground.

(U) 5.2.14.21 Bonding of cables penetrating a secure processing center. In metallic hull surface ships having a RED high level electrical signal distribution system, shielded or armored cables penetrating the electrical perimeter barrier of a secure processing center shall have the outer-most shield (and armor, if applicable) bonded to ground in accordance with the following:
Pri-2.

- a. The outer-most shield (and armor, if applicable) shall be bonded to ground on the inside of the secure processing center at the point where the cable penetrates the electrical perimeter barrier.

UNCLASSIFIED

MIL-STD-1680C(SH)
17 March 1993

APPENDIX F

INSPECTION CHECK-OFF SHEETS - Continued

(U) b. The methods of bonding shields and armor shall be in accordance with one or more of the following:

(1) Figures 11 through 14, Appendix I.

(2) Any of the methods of MIL-STD-1310.

(3) Any of the methods in DOD-STD-2003 that provide for the bonding of shields or armor.

(4) The use of ground ring kits and connectors designed to provide shield bonding via the connector hardware, including coaxial and triaxial.

c. In addition, cable shields shall be bonded to ground as applicable in 5.2.14.19 and 5.2.14.20.

NOTE:

Prior to 1976, the installation criteria allowed cables to penetrate the secure processing center without the shield bonding to ground; such items shall not be reported as a discrepancy if installed under the previous criteria.

UNCLASSIFIED

MIL-STD-1680C(SH)
17 March 1993

APPENDIX F

INSPECTION CHECK-OFF SHEETS - Continued

- * (U) 5.2.14.22 Bonding of spare and unused cables and conductors. Unused or spare conductors and shields (and armor, if applicable) of RED cables which penetrate the electrical perimeter barrier of a secure processing center shall be bonded to ground at both ends. This requirement does not apply to conductors in Automated Single Audio System cables identified in NOTE 29 in NAVELEX Drawing 28687-0125013 Rev F. This requirement is also applicable to BLACK cables in a metallic hull surface ship having a RED high level electrical signal distribution system. Unused or spare conductors shall have a length sufficient to be connected to any of the terminations. Pri-2.

NOTE: Prior to 1976, the installation criteria allowed spare conductors in BLACK or unused cables in BLACK cable runs to be ungrounded; such items shall not be reported as a discrepancy if installed under the previous criteria.

(U) 5.2.14.23 Bonding of conduit and metal ducts. Conduit or metal ducts required in 5.1.10.3, 5.1.10.6, 5.1.10.7, 5.1.10.10, 5.1.10.17 and 5.2.10.18 shall be bonded to ground within 3 inches of each exposed end, and at points of electrical perimeter barrier penetration. Conduit shall be bonded to boxes or equipment by welding or by the use of bushing and locknuts. Conduit fitting covers shall be tack-welded to fittings where possible or sealed with a conductive non-corroding sealant if welding is not practical. All cover retaining screws shall be in place. Conduit runs that contain pipe unions shall have the nut (collar) portion tack-welded to the male tail piece after the union has been made up. The methods of bonding are illustrated on Figures 16 and 17 of Appendix I. Pri-3.

UNCLASSIFIED

MIL-STD-1680C(SH)
17 March 1993

APPENDIX F

INSPECTION CHECK-OFF SHEETS - Continued

- * (U) 5.2.14.24 Conduit. Conduit shall be of the thin or thick walled, ferrous or non-ferrous type. Flexible type conduit, where used, shall be of RF-tight construction. Greenfield and similar spiral flexible conduit shall not be acceptable. Publication NAVSEA S9407-AB-HBK-010 is a prime source of data concerning acceptable flexible conduit and related bonding techniques. RF-tight conduit may define the electrical perimeter barrier of a secure processing center and alleviate cable separation requirements. Pri-3.

(U) 5.2.14.25 Bonding of non-processing equipments and devices. Electrical lighting fixtures and other electrical non-processing equipment and devices in a secure processing center need not have bonding applied as a TEMPEST requirement.

NOTE: Not an FTA inspection item. This is a design information item.

(U) 5.2.14.26 Removal of armor. The armor may be stripped from shielded cable as an alternative to bonding the armor to ground.

NOTE: Not an FTA inspection item. This is a design information item.

UNCLASSIFIED

MIL-STD-1680C(SH)
17 March 1993

APPENDIX F

INSPECTION CHECK-OFF SHEETS - Continued

(U) 5.2.15 Electrical perimeter barrier. That part of the secure processing center that processes RED electrical information shall be enclosed by an electrical perimeter barrier. This requirement is not applicable to non-metallic hull surface ships. Pri-1 if system is high level. Pri-2 if system is low level.

(U) 5.2.15.1 Electrical perimeter barrier doors. Doors, with the exception of emergency exit doors, which form a part of the electrical perimeter barrier of a secure processing center of metallic hull surface ships having a RED high level electrical signal distribution system shall be equipped with a door closer conforming to FF-H-121. Pri-3.

Each side of such doors, except normal access doors, shall have a sign stating, "DOOR NOT TO BE LEFT OPEN WHILE OPERATING RED PROCESSING EQUIPMENT." Pri-2.

Additional normal access door requirements are specified in 5.3.1.2 through 5.3.1.5.

UNCLASSIFIED

MIL-STD-1680C(SH)
17 March 1993

APPENDIX F

INSPECTION CHECK-OFF SHEETS - Continued

- * (U) 5.3.1 Security spaces. Spaces or stations having RED processing equipment shall be designated a Secure Processing Center, Secure Remote Area, Remote Area or an Exposed Remote Station, as applicable. These spaces shall meet the physical security requirements of OPNAVINST 5510.1 as implemented herein and commensurate with the classification of the information to be handled. An Exposed Remote Station shall have only secure voice operating positions. Pri-CCA.

(U) 5.3.1.1 Physical perimeter barrier. The physical perimeter barrier (PPB) of a secure processing center and a secure remote area shall be installed in a manner which will preclude access to, or viewing of, classified data within the space by unauthorized personnel. Pri-1.

(U) 5.3.1.1.1 Maintenance access panels. The physical perimeter barrier may have a maintenance access panel for the purpose of providing access from outside the space to equipment within the space. If the panel location outside of the physical perimeter barrier is in a passageway or compartment not subject to frequent usage by personnel, the panel shall be secured with a hasp and a combination padlock conforming to FF-P-110, type DE, class 2. Otherwise, the panel shall be secured with studs or bolts and nuts with center to center spacing not to exceed 4 inches. Pri-2.

UNCLASSIFIED

MIL-STD-1680C(SH)
17 March 1993

APPENDIX F

INSPECTION CHECK-OFF SHEETS - Continued

(U) 5.3.1.2 Normal access. A secure processing center shall have only one normal access. A normal access door shall be plainly identified by a sign which reads "RESTRICTED AREA - NO ADMITTANCE BEYOND THIS POINT " (see OPNAV Form 5510-14). Pri-2.

NOTE: In the SSBN-726 Class, dual access doors may be installed providing each is equipped with a 3-tumbler combination lock for the unmanned condition and a push-button cipher-type combination lock for access security when the space is manned.

NOTE: Prior to 1988 the signs read "RESTRICTED AREA - KEEP OUT - AUTHORIZED PERSONNEL ONLY: (OPNAV Form 5510-12)." These signs, installed under earlier criteria, shall not be cited as a discrepancy.

(U) 5.3.1.3 Normal access door requirements, metallic hull surface ships. The normal access door to a secure processing center in metallic hull surface ships shall be in compliance with the following:

- * a. Metal joiner doors shall be similar to the honeycomb core (Drawing 805-4629248), type H door (Drawing 804-1642434), type A door (Drawing 804-1642752) or type L door (post office) (Drawing 804-1643220). They shall be tight fitting and constructed in such a manner which will preclude unauthorized removal of and hamper access to hinge pins and anchor bolts, as well as obstruct access to locking bolts between the door and frames. A dutch door shall not be installed. Pri-2

UNCLASSIFIED

MIL-STD-1680C(SH)
17 March 1993

APPENDIX F

INSPECTION CHECK-OFF SHEETS - Continued

- (U) b. The door shall be equipped with a door closer conforming to FF-H-121. Pri-2.
- c. The door shall be fitted with a latch, and a manipulation-resistant three-tumbler combination lock, style I, MIL-L-15596. Pri-1.

Combination locks shall be equipped with a No. 50 pinch proof deadlock extension. Pri-3.

For new construction ships and new installations in active fleet ships, combination locks shall be equipped with a top reading dial. Pri-2.

- * d. The door shall be self locking and equipped with a pushbutton electrical or mechanical access control (cipher lock). These access controls are intended for use when the space is manned at which time the combination mechanism may be disengaged. The access control satisfies the self locking requirement. Pri-2

- e. The door may be equipped with a facility for personnel identification.

UNCLASSIFIED

MIL-STD-1680C(SH)
17 March 1993

APPENDIX F

INSPECTION CHECK-OFF SHEETS - Continued

(U) f. Where the normal access door is in a bulkhead that is part of an air tight perimeter, the air tight integrity may be maintained by co-locating the air tight door with the joiner door, or by adding a vestibule. The fittings specified in items a. through e. shall be on the joiner door. Pri-3.

(U) 5.3.1.3.1 Secure remote area doors. Normal access door(s) and emergency exit(s), if used, of a secure remote area shall be of the same structural characteristics as its surrounding bulkhead. There are no limitations to the number of access(es) and exit(s). Dutch doors shall not be installed. Emergency exits shall be operable only from inside the space. Normal access doors shall be equipped as follows:

a. With a built-in manipulation-resistant three-tumbler combination lock, Style I, MIL-L-15596, or a Type DC or DE, Class 1 or 2, combination padlock, FF-P-110, and hasp. Pri-1.

b. A sign on the outer side of the door(s) which reads, "RESTRICTED AREA - NO ADMITTANCE BEYOND THIS POINT." Pri-2.

NOTE: Prior to 1988 the signs read "RESTRICTED AREA - KEEP OUT - AUTHORIZED PERSONNEL ONLY" (OPNAV Form 5510-12). These signs, installed under earlier criteria, shall not be cited as a discrepancy.

UNCLASSIFIED

MIL-STD-1680C(SH)
17 March 1993

APPENDIX F

INSPECTION CHECK-OFF SHEETS - Continued

- * (U) c. The door shall be equipped with a door closer conforming to FF-H-121. This requirement is applicable only when the secure remote area is a normally manned space. This requirement does not apply to watertight/airtight doors. Pri-2.

- * d. The door may be self locking and equipped with a pushbutton, electrical or mechanical access control (cipher lock). These access controls are intended for use when the space is manned at which time the combination mechanism may be disengaged. The access control satisfies the self locking requirement. This requirement is applicable only when the secure remote area is a normally manned space. This requirement does not apply to watertight/airtight doors that open to a weatherdeck. Pri-3.

(U) 5.3.1.4 Normal access door requirements, submarines. The normal access door to a secure processing center in a submarine shall be in compliance with the following: Pri-CCA.

- a. The door shall be one of the following:
 - * (1) Sliding type metal joiner doors shall be similar to type C (Drawing 804-1631627) which are tight fitting and constructed in a manner that will preclude unauthorized removal. The door shall be fitted with a built-in combination lock and locking hardware, and fabricated in accordance with Drawing SSN 637-604-2159329 and SHIPALT 1314.

UNCLASSIFIED

MIL-STD-1680C(SH)
17 March 1993

APPENDIX F

INSPECTION CHECK-OFF SHEETS - Continued

- * (U) (2) Swinging type metal joiner doors shall be similar to the honeycomb core (Drawing 804-4629248), type H door (Drawing 804-1642434), or type A door (Drawing 804-1642752), tight fitting, and constructed in a manner which will preclude unauthorized removal of and preferably hamper access to hinge pins and anchor bolts, as well as obstruct access between locking bolts and the frame. The door shall be fitted with a latch, and MIL-L-15596. Combination locks shall be equipped with a No. 50 pinch proof deadlock extension. For new construction ships and new installations in active fleet ships, combination locks shall be equipped with a top reading dial. The door shall be equipped with a door closer conforming to FF-H-121. A Dutch door shall not be installed.

- b. Equipped to be self locking.

- c. Existing doors shall be installed or modified in accordance with SHIPALT SSBN-207, SSN-938 or SS-966.

- * d. A sign shall be installed on the outside of the door which reads, "RESTRICTED AREA - NO ADMITTANCE BEYOND THIS POINT" (see OPNAV Form 5510-14).

NOTE: In the SSBN-726 and SSN-21 Classes, dual access doors may be installed providing each is equipped with a three-tumbler combination lock for the unmanned condition and a pushbutton, electrical or mechanical access control (cipher lock) for access control when the space is manned.

UNCLASSIFIED

MIL-STD-1680C(SH)
17 March 1993

APPENDIX F

INSPECTION CHECK-OFF SHEETS - Continued

(U) 5.3.1.5 Normal access door requirements, non-metallic hull ships. The normal access door to a secure processing center in a non-metallic hull ship shall be in compliance with the following:

- a. The door shall be in accordance with Drawing MSC-122-1842876, or constructed of material comparable to that of the surrounding bulkhead. Pri-2.

- b. The door shall be tight fitting and constructed in a manner which will preclude unauthorized removal of and preferably hamper access to hinge pins and anchor bolts, as well as obstruct access to lock bolts between the door and frame. Pri-2.

- c. The door shall be equipped with a door closer conforming to FF-H-121. Pri-2.

- d. The door shall be fitted with a latch, and a manipulation-resistant three-tumbler combination lock, style I, MIL-L-15596. Pri-1.

Combination locks shall be equipped with a No. 50 pinch proof deadlock extension. Pri-3.

For new construction ships and new installations in active fleet ships, combination locks shall be equipped with a top reading dial. Pri-2.

UNCLASSIFIED

MIL-STD-1680C(SH)
17 March 1993

APPENDIX F

INSPECTION CHECK-OFF SHEETS - Continued

- * (U) e. The door shall be self-locking. The door shall be equipped with a pushbutton electrical or mechanical access control (cipher lock). These access controls are intended for use when the secure processing center is manned, at which time the combination tumbler mechanism may be disengaged. The access control satisfies the self-locking requirement. Pri-2.

- f. The door may be equipped with a facility for personnel identification.

- g. A sign on the outer side of the door which reads "RESTRICTED AREA - NO ADMITTANCE BEYOND THIS POINT." Pri-3.

(U) 5.3.1.6 Emergency exits. Emergency exits shall be operable only from inside the secure processing center or secure remote area. Pri-1.

Where doors are used as emergency exits, the door shall be tight fitting and constructed in a manner which will preclude unauthorized removal of, and preferably hamper access to, hinge pins and anchor bolts, as well as obstruct access to locking bolts between the door and frame. Pri-2.

UNCLASSIFIED

MIL-STD-1680C(SH)
17 March 1993

APPENDIX F

INSPECTION CHECK-OFF SHEETS - Continued

- * (U) Doors which form a part of the electrical perimeter barrier shall conform to 5.2.15.1. A dutch door shall not be installed as an emergency exit. Pri-2.

- (U) 5.3.1.7 Acoustical isolation. Normal speech level within a secure processing center shall not be capable of being monitored outside the physical perimeter barrier of the secure processing center taking into account both physical perimeter barrier construction and normal ambient noise. Pri-3.

- (U) 5.3.1.8 Visual barrier. A curtain or other visual barrier shall be installed inside the secure processing center behind the message passing window and the normal access door, where viewing classified information is possible within a radius of 10 feet of the point of visual penetration from outside the space. Pri-1.

- * (U) 5.3.1.9 Intrusion alarm. An intrusion alarm system shall be provided for the access(es) and exit(s) serving the physical perimeter barrier of a secure processing center or secure remote area in a surface ship. This system shall provide a means of warning when any access or exit in the space is opened, or when there is a loss of power to the alarm system. The system shall provide the following functions and safeguards: Pri-3.
 - a. Audible and visual indicators of an alarm shall be provided at the supervisory position within the space.

UNCLASSIFIED

MIL-STD-1680C(SH)
17 March 1993

APPENDIX F

INSPECTION CHECK-OFF SHEETS - Continued

- * (U) b. Alarm signals shall be extended to audible and visual indicators at one or more remote stations capable of responding to an alarm condition. A supervisory feature shall be provided on remote alarm lines. (SEE NOTE 1)

- c. Any access or exit opening, momentary or otherwise, shall hold an alarm condition until disabled at the supervisory position. (See note 2)

- d. A disconnect feature within the space shall be connected to permit the cutout of remote alarms when the space is manned. (See note 1)

- * e. A variable (for example, 15-60 seconds) time delay function shall be provided and connected to permit the space to be vacated without generating local or remote alarms. (See NOTE 2.)

UNCLASSIFIED

MIL-STD-1680C(SH)
17 March 1993

APPENDIX F

INSPECTION CHECK-OFF SHEETS - Continued

- * (U) f. When the space is manned, the normal access door sensor(s) shall have a disconnect feature. The emergency exit sensor(s) shall be connected to the alarm system at all times and shall not have a disconnect feature installed, except the disconnect features inherent in the IC/SM Alarm Switchboard. A primary power switch shall not be considered an alarm cutout function. Disabling, disconnecting or cutout features of an alarm sensor shall provide, as a minimum, an abnormal visual indication. Note that secure remote areas may have more than one normal access door and may have a disconnect feature installed.

- g. An audible alarm indicator shall be capable of being silenced following any initial energizing of the indicator. Such a silencing feature shall not disable any circuit between the sensor(s) and the visual indicator(s).

- * h. Switches, sensors and primary power shall be located within the space. Door or scuttle sensor switches shall be tamper-resistant in accordance with Drawing 401-1973965, except that the lock wire specified in the Drawing is not required. (See note 2)

UNCLASSIFIED

MIL-STD-1680C(SH)
17 March 1993

APPENDIX F

INSPECTION CHECK-OFF SHEETS - Continued

- * (U) i. A power failure relay shall be connected to the alarm system input power so that an alarm will be initiated at the remote stations(s) whenever there is a loss of power and the space is unmanned. The power failure relay contacts shall be connected in parallel with the summary intrusion alarm. The alarm system shall be permanently connected to BLACK power within the secure processing center or secure remote area. (See note 2)

- j. An extended intrusion or power failure alarm to the remote station(s) shall be a separate alarm signal, and not a summary of other alarm signals terminating within the space (for example, the frequency standard alarm).

NOTE 1: Prior to 1979, a remote feature was not an installation requirement and shall not be reported as a discrepancy if installed under the previous criteria.

- * NOTE 2: Prior to 1982, the installation criteria did not require the holding feature for a momentary opening, the manned or unmanned switch with its time delay feature, the tamper-resistant door switch and the power failure relay. The absence of such items shall not be reported as a discrepancy if installed under the previous criteria.

UNCLASSIFIED

MIL-STD-1680C(SH)
17 March 1993

APPENDIX F

INSPECTION CHECK-OFF SHEETS - Continued

(U) 5.3.1.11 Message passing windows. Message passing windows may be installed between a secure processing center and the adjacent area for the purpose of receipt and delivery of message traffic. Message passing windows in surface ships shall be in accordance with Drawing 804-5184152. Pri-2.

NOTE 1: This type window can be identified by a small label plate on the inside of the door or on adjacent bulkhead which reads "NAVSEA DWG NO 804-5184152 MFG BY _____".

- * NOTE 2: Prior to 1983, the window was specified to be in accordance with Drawing 805-1749004 with modifications to provide the following security features:
- Bars welded or riveted into place.
 - Bars extend within 6 inches of the shelf.
 - Windows equipped with a solid metal door having a locking device controlled only from within the secure processing center.

Such a window shall not be reported as a discrepancy if installed under the previous criteria.

- * (U) 5.3.1.12 Location of cryptographic and classified information processing equipment. Cryptographic equipment and other classified information processing equipment may be located outside secure processing centers and secure remote areas provided the equipment and classified information is afforded adequate physical security. Pri-1.

UNCLASSIFIED

MIL-STD-1680C(SH)
17 March 1993

APPENDIX F

INSPECTION CHECK-OFF SHEETS - Continued

- * (U) 5.3.1.12.1 Location of cryptographic equipment.
Cryptographic equipment should be located in a secure processing center. Cryptographic equipments may be located external to a secure processing center provided they are physically mounted in an approved security container. Specific NAVSEA approval shall be obtained for proposed locations external to a secure processing center. Cryptographic equipments which are commonly located external to a secure processing center along with the associated approved security containers are as follows: Pri-1.

a. TSEC/KG-40, see the following drawings:

10 D 2562
10 D 2313
10 D 2314
10 D 2315
10 D 2316
10 D 2317
10 B 2318
10 B 2319
10 B 2320
10 B 2321
10 B 2322
10 B 2323
10 B 2325
10 C 2327
10 D 2328

The secure cover shall be equipped with a combination padlock conforming to FF-P-110, type DE, class 2.

- b. TSEC/KI-1(), see Drawing 408-2228164 and RE 2698862. The physical security strap shall be equipped with a combination padlock conforming to FF-P-110, type DE, class 2.

UNCLASSIFIED

MIL-STD-1680C(SH)
17 March 1993

APPENDIX F

INSPECTION CHECK-OFF SHEETS - Continued

- (U) c. TSEC/KG-45, the electronic equipment cabinet that contains the OR-209/SRQ-4. The security bar shall be equipped with a combination padlock conforming to FF-P-110, type DE, class 2.
- d. TSEC/KGV-11. (Mounted on the TD-1271B/U in OK-454(V)/WSC or OK-455(V)/WSC control Monitor Group) (see Bendix Field Engineering Drawings 15151ASY3533258-0501 and 15151ASY3533259-0501 and A & J Manufacturing Co. Drawing 08060-250-1.) The locking bar shall be equipped with a combination padlock conforming to FF-P-110, type DE, class 2.
- e. TSEC/KG-44 is mounted in a physically secure part of the OL-350/SMQ-11 cabinet. The security compartment within the SMQ-11 cabinet in which the KG-44 is installed shall be locked with a combination padlock conforming to FF-P-110, type DE, class 2.

Note: The compartment of the SMQ-11 cabinet may have a built-in combination lock conforming to style I, MIL-L-15596.

- f. TSEC/KGV-8 is mounted in the Joint Tactical Information Distribution System (JTIDS) CY-8589/URC-107(V) Electronic Cabinet Assembly (ECA). The two built-in hasps on the right front and rear of the ECA shall be equipped with combination padlocks conforming to FF-P-110, type DE, class 2.

UNCLASSIFIED

MIL-STD-1680C(SH)
17 March 1993

APPENDIX F

INSPECTION CHECK-OFF SHEETS - Continued

- * (U) 5.3.1.12.2 Location of classified information processing equipment. Classified information processing equipment may be located outside a secure processing center or secure remote area when one or more of the following conditions are met: Pri-1.
- a. The media containing classified information, such as disks and magnetic tapes, may be removed from the RED processing equipment and locked in an approved container identified in OPNAVINST 5510.1. No classified information shall remain resident in an accessible memory or on a hard disk.
 - b. The power and/or signal lines to the RED equipment can be secured from a secure processing center or secure remote area when the space is unmanned.
 - c. Install a local primary power switch serving the RED equipment which can be locked with a combination padlock conforming to FF-P-110, type DE, class 2, when the space is unmanned.
 - d. The RED equipment may be enclosed in an expanded metal cage, a container, or protected by a security strap secured with a combination padlock conforming to FF-P-110, type DE, class 2. If the equipment or sub-system has an electronic or paper hard-copy display and (b) above is not met, a visual barrier shall be provided to prevent unauthorized viewing of the classified information being processed.

UNCLASSIFIED

MIL-STD-1680C(SH)
17 March 1993

APPENDIX F

INSPECTION CHECK-OFF SHEETS - Continued

(U) 5.3.1.13 Cryptographic repair facilities. Shipboard cryptographic repair facilities are not secure processing centers. However, physical security criteria for a secure processing center shall be applied to the cryptographic repair facility. Pri-1.

(U) 5.3.1.14 Physical security of terminal boxes, cable boxes and similar enclosures. Junction, terminal and cable boxes, cable cabinets and similar enclosures containing RED cables shall meet the following minimum physical security criteria where installed in other than a secure processing center, secure remote area, or remote area. Cable pull boxes are excluded from these requirements. The box or cabinet shall be constructed such that evidence of forced entry or tampering would be readily apparent. Hinge pins, screws, bolts, or fastening devices as required shall be tack welded, or the cover shall be secured at opposite ends with combination padlocks conforming to FF-P-110, type DE, class 2, so as to prevent removal by other than forcible means. The box shall be located in such a manner as to be readily accessible for visual inspection. Pri-2.

UNCLASSIFIED

MIL-STD-1680C(SH)
17 March 1993

APPENDIX F

INSPECTION CHECK-OFF SHEETS - Continued

(U) 5.3.1.15 Paper destruction equipment. If shredding machines are used for the destruction of classified paper in a secure processing center, secure remote area or remote area, they shall meet the requirements of FF-S-1169, wherein the width of shreds shall not exceed 1/32-inch with a plus tolerance of 1/64-inch. When cross cut is required, such as for destruction of paper communication security material, the shredder shall meet the requirements of NACSI-4010, wherein the dimensions of shreds shall not exceed 3/64-inch in width by 1/2-inch in length or 1/35-inch in width by 7/8-inch in length. Proposals for substitute equipment employing incendiary, pulverizing, or pulping methods shall be submitted to NAVSEA (Code 03K222) for approval. Pri-2.

NOTE: The following destruction equipments are acceptable:

- a. ITMUS Model 007 shredder.
- b. CCAM 1092 crosscut tabletop shredder.
- c. Destroyit Model 51-161 shredder.
- d. Shredmaster Model Crosscut 200 shredder.
- e. Somat Navy Model 5 wet pulper when equipped with a security screen having apertures not exceeding 0.25-inch in diameter.

UNCLASSIFIED

MIL-STD-1680C(SH)
17 March 1993

APPENDIX F

INSPECTION CHECK-OFF SHEETS - Continued

(U) 5.3.1.16 Cable marking. RED high level cable runs serving a RED electrical processing system shall be marked with a 1-inch wide band of red color at the entrance to equipment, junction boxes, space penetrations and other points which constitute a physical discontinuity in the RED cables. Common marking of bundled cables is permitted. Paint or red tape may be used. This requirement is not applicable to submarines. Pri-2.

- * (U) 5.3.1.16.1 Cable designators. On surface ships with RED a high level signal distribution system, RED high level cables shall suffix the letter symbol "/Q" to the normal cable designator (for example, R-RY/Q Radio Teletype). Cables designated as RED low level, secure voice and RED CCTV audio and baseband video shall suffix a letter symbol "/L" to the normal cable designator (for example R-RY/L Radio Teletype, R-RQ/L Secure Voice, R-TC/L CCTV). This requirement is not applicable to ships with a totally low level SEIPS. Pri-2.

NOTE: Prior to 1979, the cable designator for RED low level cables did not exist; some RED low level cables may have a RED high level designator; such items shall not be reported as a discrepancy if installed under the previous criteria.

UNCLASSIFIED

MIL-STD-1680C(SH)
17 March 1993

APPENDIX F

INSPECTION CHECK-OFF SHEETS - Continued

(U) 5.3.2 Modification of call signal station, type IC/D. Call signal station, type IC/D installed in accordance with Drawing S6501-73801, within the physical perimeter barrier of a secure processing center shall be modified as follows (see Figure 18, Appendix I): Pri-2.

- a. Mount a relay (NSN 5945-00-893-1366) on the bottom plate of the rotary selector switch, piece 38, using the existing screws.

- b. Disconnect the lead from the howler, piece 40, that is connected to the terminal board assembly, piece 29, and reconnect to terminal number 7 of the relay.

- c. Disconnect the lead from the attenuator, piece 39, that is connected to the terminal board assembly, piece 29, and reconnect to terminal number 8 of the relay.

- d. Install new leads from terminal numbers 2 and 3 of the relay to the howler terminals on the terminal board assembly.

- e. Install jumper leads from terminal number 2 to terminal number 6 and from terminal number 3 to terminal number 5 of the relay.

UNCLASSIFIED

MIL-STD-1680C(SH)
17 March 1993

APPENDIX F

INSPECTION CHECK-OFF SHEETS - Continued

- (U) f. Affix a label to the front of IC/D station enclosure with the following information: "MODIFIED IAW MIL-STD-1680".

NOTE 1: Modifications to units accomplished under previous installation standards will have a sign reading "MODIFIED IAW NAVSHIPSINST C5510.33"; these signs are acceptable.

NOTE 2: AN/WTC-2(V) telephone sets have a signaling system and loudspeaker circuit that is acceptable for installation without modification.

- * (U) 5.3.3 Patch panel identification. When compatible RED and BLACK patch panels are installed, RED patch panels shall be colored red. Patch panels for BLACK electrical distribution systems shall be colored black or gray. Pri-2.

UNCLASSIFIED

MIL-STD-1680C(SH)
17 March 1993

APPENDIX F

INSPECTION CHECK-OFF SHEETS - Continued

(U) 5.3.3.1 Patch panel physical separation. Patch panels for the RED and BLACK electrical distribution systems which are electrically compatible, in that they could provide an operable circuit via crosspatching with standard length (unmodified) patch cords, shall be separated by a minimum distance of 6 feet on surface ships and 3 feet on submarines. Pri-CCA.

NOTE: In the SSN-594 class submarines, a minimum separation of 32 inches is required between the SB-1203/UG and the SB-1210/UGQ.

(U) 5.3.4 RED and BLACK system sharing. RED and BLACK electrical distribution systems may share the same processing equipment when specified in NAVSEA drawings or documents to meet operational requirements. A transfer, patching or switching system used to connect a position alternately to a RED and BLACK system shall: Pri-2.

- a. Have clearly identified controls with a visual status indication at the operating position or equipment terminal.

- b. Be secure against accidental or unauthorized connection of circuit, channel, or position to the non-secure or secure system.

UNCLASSIFIED

MIL-STD-1680C(SH)
17 March 1993

APPENDIX F

INSPECTION CHECK-OFF SHEETS - Continued

- (U) c. Be impossible to by-pass unintentionally.
- d. For semiautomatic or automatic systems where manual manipulation is not employed, provide fail-safe operation by circuit lock-up or positive diversion to a secure system in the event of equipment malfunction.
- e. Be considered a part of the secure system to which it will be connected and be afforded the same physical security.

(U) 5.3.4.1 RED operating positions. As a security design objective, RED operating positions shall be installed in a secure processing center or secure remote area. RED operating positions may be installed in a remote area, and secure voice operating positions may be installed at an exposed remote station, when specified in NAVSEA drawings and documents. When a remote operating position is connected to a RED electrical distribution system, it becomes part of that system.

NOTE: Not an FTA inspection item. This is a design information item.

UNCLASSIFIED

MIL-STD-1680C(SH)
17 March 1993

APPENDIX F

INSPECTION CHECK-OFF SHEETS - Continued

(U) 5.3.4.1.1 RED system interconnection. The RED electrical processing system shall be protected against inadvertent breakout of information in a recoverable form in a space that is not manned or secured. A secure processing center and a secure remote area have facilities installed that provide for security features in a manned or unmanned condition. The RED electrical processing system may interconnect between such spaces with no additional security features required. RED electrical processing system extensions from one of these spaces to a remote area or exposed remote station shall comply with one or more of the following: Pri-1.

- a. Via a semiautomatic or automatic system. Such a system shall have a program that can control access to the system output signal lines, and provide fail-safe operation by circuit lock-up in the event of equipment malfunction.

- b. To a parallel data input of equipment via a disconnect switch (for example, SA-1816/UYK Rotary Switch) located at the signal source.

- c. To or from a unit of equipment via an SA-734/SG or SA-2371/SG Switch Box located in the secure processing center or secure remote area.

UNCLASSIFIED

MIL-STD-1680C(SH)
17 March 1993

APPENDIX F

INSPECTION CHECK-OFF SHEETS - Continued

(U) d. To secure voice equipment as specified in 5.3.5.5.

* e. To a remote terminal which requires entering a password before classified information can be received.

* f. The RED line may run directly to a teletypewriter orderwire that is used exclusively for technical control with another ship or station provided the space is adjacent to and under the control of the Communications Center and its personnel.

UNCLASSIFIED

MIL-STD-1680C(SH)
17 March 1993

APPENDIX F

INSPECTION CHECK-OFF SHEETS - Continued

(U) 5.3.4.2 BLACK transmit operating positions. BLACK transmit teletypewriter operating positions that are located in the secure processing center shall be physically separated from similar RED transmit teletypewriter operating positions. This physical separation shall be accomplished by a physical barrier, the purpose of which is to clearly differentiate the operating positions. In general, adequate spacing, expanded metal screens, railing, or filing cabinets, in conjunction with clear position marking will suffice. Pri-2.

* (U) 5.3.4.3 Shared teletypewriter circuits. A type SA-734/SG, SA-2371/SG or SA-2626/BR Switch Box shall be installed in the signal line(s) of each teletypewriter or facsimile equipment used alternately in both RED and BLACK electrical signal distribution systems as specified in 5.1.1 and 5.3.5.1.1 (see Drawing RE 2682997). The switch box shall be located in a secure processing center or secure remote area for shared equipment within that space. When the shared circuit is in a remote area and only one switch box is used for both interface and disconnect, it shall be located in the SPC or SRA. When the interface and disconnect switches are separate, the disconnect switch shall be located in the SPC or SRA, and the interface switch in the remote area with the shared equipment: Pri-1.

a. At the operating position of the shared equipment.

UNCLASSIFIED

MIL-STD-1680C(SH)

17 March 1993

APPENDIX F

INSPECTION CHECK-OFF SHEETS - Continued

- (U) b. Where directly connected as the only control provided for shared equipment located in a remote area.

 - c. As a disconnect to a switch box when another switch box is installed with the shared equipment at a remote area.
- * (U) 5.3.4.3.1 Cautionary signs for shared operating positions. Where a shared operating position consists of a single equipment having independent send and receive signal lines, such as an AN/UGC-48, requiring dual SA-734/SG or SA-2371/SG Switch Boxes, both switch boxes shall be in the same position. A cautionary sign stating that both switches shall be in the same position (classified or unclassified) at all times shall be posted adjacent to or on either the applicable switches or their associated indicator lights. Pri-2.

UNCLASSIFIED

MIL-STD-1680C(SH)
17 March 1993

APPENDIX F

INSPECTION CHECK-OFF SHEETS - Continued

(U) 5.3.4.6 Speaker disconnect switch. Secure voice monitor speakers shall be capable of being locally disconnected from signal lines. The disconnect feature may be located in the local telephone set (for example, TA-970/U) or on the speaker amplifier. Pri-2.

- * (U) 5.3.5 Telephone push-to-operate feature. In surface ships, rotary, pulse or tone dial telephones having a shore-tie capability, installed within the physical perimeter barrier of a secure processing center shall be equipped with a push-to-operate feature. This requirement is not applicable to the TA-866() in the AN/STC-1 or AN/STC-2 Dial Telephone Terminals or other telephone handsets with a push-to-talk feature and buffer amplifier in the receive element such as the STU-III. Pri-3

(U) 5.3.5.1 Telephone sets with intercommunication units. A combination telephone station, such as the TA-997/STC-2 Automatic Telephone Terminal, which permits a calling station to monitor the called station without a positive personal response or a continuing visual or audible indication, should not be installed within a secure processing center. If this unit is used, it shall be modified to provide continual audible and visual indications that it is in use. These indications shall be of a design to be easily seen or heard in the ambient noise and light levels in the space. Pri-3.

UNCLASSIFIED

MIL-STD-1680C(SH)
17 March 1993

APPENDIX F

INSPECTION CHECK-OFF SHEETS - Continued

(U) 5.4 Temporary installations of RED processing equipment.
Type commander approved temporary installations of RED processing equipment shall conform to the minimum TEMPEST-related configuration control and physical security criteria set forth below. A temporary installation shall not exceed 9 months. Prior to or at the end of the 9 month period, the equipment will be removed, or reinstalled in conformance with 5.1, 5.2 and 5.3. The minimum installation criteria is as follows: Pri-CCA.

- a. The RED and BLACK signal distribution systems shall be electrically interfaced as specified in 5.1.1

- b. The RED equipment shall be connected to primary power as specified in 5.1.2.1 and 5.1.2.2.

- c. Battery for a RED signal distribution system, if required, shall be RED battery.

- d. RED cable shall be shielded. The shield shall be bonded to ground at each end of the cable.

- e. RED high level cable shall be separated from other cable to the maximum extent possible as specified in 5.1.10.12 through 5.1.10.15.

UNCLASSIFIED

MIL-STD-1680C(SH)
17 March 1993

APPENDIX F

INSPECTION CHECK-OFF SHEETS - Continued

- (U) f. The RED equipment shall be bonded to ground with a class B bond or a class C bond strap.

- g. The location of cryptographic equipment shall be as specified in 5.3.1.12.1.

- h. The location of RED processing equipment shall be as specified in 5.3.1.12.2.

Additional criteria may be imposed as required on a case-by-case basis. An inspection is required by a certified FTA immediately after the installation is completed. The VTI report shall note that the installation is temporary and that the inspection of the temporary installation was conducted as specified herein.

UNCLASSIFIED

MIL-STD-1680C(SH)
17 March 1993

APPENDIX F

INSPECTION CHECK-OFF SHEETS - Continued

APPENDIX A - SPECIAL INTELLIGENCE SPACE INSTALLATIONS - Continued

(U) 50.1.1 TEMPEST status. The following establishes the TEMPEST-related configuration control status for the various subsystems processing SI information:

- a. RED processing equipment, except PICS and teletypewriter equipment, should be SPAWAR TEMPEST-approved.

(NOTE: Not an FTA inspection item; however, equipment in question should be noted in the inspection report.)

- * b. Teletypewriter equipment of a RED processing system shall be low level. Pri-1 for high level systems. Pri-2 for low level systems not listed in paragraphs 50.1, 50.2, 50.3 or Appendix D.

- * c. An SI teletypewriter circuit between an SI space and a remote terminal in another SI space shall be operated with RED low level signaling. Pri-1.

UNCLASSIFIED

MIL-STD-1680C(SH)
17 March 1993

APPENDIX F

INSPECTION CHECK-OFF SHEETS - Continued

APPENDIX A - SPECIAL INTELLIGENCE SPACE INSTALLATIONS - Continued

- * (U) d. Equipment serving as a RED/BLACK signal interface, except for PICS equipment, shall be a SPAWAR TEMPEST-approved device as specified in 5.1.1.

- * e. The PICS equipment should be a SPAWAR TEMPEST-approved isolation device. The RED/BLACK signal interface boundary in PICS equipment is defined as any of the following: (see Figure 19, Appendix I). Pri-CCA.
 - (1) The Radio Frequency (RF) input to a system radio receiver: the antenna and antenna coupler is BLACK; the radio receiver is RED.

 - (2) The antenna control input or output of a receiving or processing unit which processes RED information: the antenna components are BLACK; the unit receiver or processor is RED.

 - (3) The navigational data input of a receiving or processing unit which processes RED information: the navigational data system (for example, gyro information, latitude and longitude data) is BLACK; the unit receiver or processor is RED.

UNCLASSIFIED

MIL-STD-1680C(SH)
17 March 1993

APPENDIX F

INSPECTION CHECK-OFF SHEETS - Continued

APPENDIX A - SPECIAL INTELLIGENCE SPACE INSTALLATIONS - Continued

- (U) (4) A unit containing multiple constant level amplifiers: The inputs to the constant level amplifiers may be audio outputs of RED or BLACK, or both, radio receivers or systems; the amplifier outputs shall be connected to the RED audio system.
- (5) A general purpose patch (or switch) facility: The BLACK interconnections are limited to RF trunk lines, receiver IF outputs, and time code generators; the RED interconnections are limited to the time code generator, and the specific timing information track of tape recorders.
- (6) A time code generator which provides timing to PICS: The input to the generator shall be from a ships frequency standard distribution amplifier (BLACK); The outputs of the generator may be connected to inputs of either RED or BLACK equipment and systems.

UNCLASSIFIED

MIL-STD-1680C(SH)
17 March 1993

APPENDIX F

INSPECTION CHECK-OFF SHEETS - Continued

APPENDIX A - SPECIAL INTELLIGENCE SPACE INSTALLATIONS - Continued

(U) b. The PICS equipment that is not SPAWAR TEMPEST-approved shall not be located in the same cabinet with antenna couplers, and shall be located a minimum of 3 feet from BLACK signal processors identified in a. above.

(U) 50.1.4 Cables. For cable separation, PICS cables on the RED side of the RED/BLACK boundary are to be considered as RED high level cables unless specifically identified as exclusively containing signaling that is in compliance with a RED low level electrical signal distribution system (see 3.44). Pri-3.

* NOTE: PICS cables may contain audio (analog and voice) that are unbalanced and dedicated to PICS. Such cables shall be considered high level in determining cable separation. The interconnecting unbalanced audio cables in the OUTBOARD system between the SA-2216/U Audio Control units and their associated audio distribution boxes and tape recorders are exempt from cable separation requirements when constant level amplifiers are installed in the RED input lines.

UNCLASSIFIED

MIL-STD-1680C(SH)
17 March 1993

APPENDIX F

INSPECTION CHECK-OFF SHEETS - Continued

APPENDIX A - SPECIAL INTELLIGENCE SPACE INSTALLATIONS - Continued

(U) 50.1.5 Non/SI voice operation. Voice operating positions shall be in compliance with the TEMPEST and physical security requirements of the following: Pri-1.

- a. BLACK only transmit radiophone and underwater telephone signal lines from the telephone or telephone control unit shall be at ground potential when not in an energized condition. The grounding feature shall occur at the electrical perimeter barrier within the space, and shall not ground the signal lines from the radio or underwater telephone equipment.

- b. Whenever a radiophone is used (when connected for other than SI), or underwater telephone transmit capability is used, the control lines shall be equipped to provide the following:
 - (1) A warning indicator light at each operating position with a sign on the indicator panel that reads: "NON-SI RADIO IN USE."

 - (2) A flashing electrical warning indicator sign visible to supervisory personnel; the sign shall read: "NON-SI RADIO IN USE."

- c. Radiophones not accredited for SI operation shall not be connected to the SI switching matrix.

UNCLASSIFIED

MIL-STD-1680C(SH)
17 March 1993

APPENDIX F

INSPECTION CHECK-OFF SHEETS - Continued

APPENDIX A - SPECIAL INTELLIGENCE SPACE INSTALLATIONS - Continued

(U) 50.2.1 Physical perimeter barrier. The physical perimeter barrier of an SI space shall be constructed or fabricated, or both, of aluminum or steel plate with a thickness not less than 0.125-inch. Non-operable elements of the physical perimeter barrier shall be fully braced and welded in place. Pri-2.

* (U) 50.2.1.1 Restriction on damage control fittings and cables. Because of the security restrictions imposed in gaining access to these spaces, no essential damage control fittings or cables shall be located within or pass through an SI space. This requirement is not applicable to damage control fittings such as smoke dampers, that may be operated by personnel within the space during normal manning. Pri-3.

(U) 50.2.1.2 Removable hatches and deck plates. Hatches and deck plates less than 10 square feet which are secured by exposed nuts and bolts (external to the SI space) shall be secured with externally attached, high security padlocks. Pri-1.

(U) The padlock keys shall be stowed in a security container conforming to AA-F-358. Pri-2.

This requirement is not applicable to submarines.

UNCLASSIFIED

MIL-STD-1680C(SH)
17 March 1993

APPENDIX F

INSPECTION CHECK-OFF SHEETS - Continued

APPENDIX A - SPECIAL INTELLIGENCE SPACE INSTALLATIONS - Continued

(U) 50.2.1.3 Vent and duct barriers. Vents, ducts, louvers, or other physical perimeter barrier openings with a cross-sectional dimension greater than 96 square inches shall be protected at the perimeter with a fixed man-proof barrier or security grille. The grille shall be fabricated of steel or aluminum grating or bars with a thickness in consonance with the physical perimeter barrier (see 50.2.1). If a grating is used, bridge center-to-center measurements shall not exceed 1.42-inches by 4-inches. Bars shall be mounted on 6-inch centers. The grating or bars shall be welded into place. This requirement is not applicable to through ducts that have no opening into the space and to submarines. Pri-3.

(U) 50.2.2 Normal access door. The normal access door shall be in accordance with Drawing 805-4629248 Metal Joiner Door with honeycomb core. The door shall have a manipulation resistant three tumbler combination lock, style II, MIL-L-15596, equipped with a top reading dial, and dial dust cover. The requirements of paragraphs 5.3.1.3.b., d., and e., shall apply to the metal joiner door. In addition, a full length astragal shall be installed on the metal joiner door or frame as appropriate. Pri-2.

UNCLASSIFIED

MIL-STD-1680C(SH)
17 March 1993

APPENDIX F

INSPECTION CHECK-OFF SHEETS - Continued

APPENDIX A - SPECIAL INTELLIGENCE SPACE INSTALLATIONS - Continued

(U) Where the normal access door, either vault type or metal joiner, is in a bulkhead that is part of an airtight perimeter, the air tight integrity may be maintained by collocating the air tight door with the vault or metal joiner door, or by adding a vestibule. This requirement is not applicable to submarines where the normal access door is as specified in 5.3.1.4.

NOTE 1: Pertinent security features of the door in conformance with Drawing 805-4629248 are:

- Door closer.
- "KEEP-OUT" sign.
- Electromechanical lock.
- Access control device (a cipher-type push-button lock system).
- Combination lock, 3-tumbler, manipulation-resistant, dust cover over top reading dial.
- Astragal (a molding extending the full length of the latching side of the door).
- Preclude unauthorized removal of hinge pins and anchor bolts.
- Obstruct access to locking bolts.

NOTE 2: Prior to 1976 the normal access door to the SI space was specified to be in accordance with Drawing 805-2217403 as modified by the standard. Such a door shall not be reported as a discrepancy, and is acceptable, if installed under the previous standard. The pertinent security features were the same as above except:

- The combination lock was manipulation-resistant only, and may not have had the dust cover and top reading dial.
- The access control device may not have been installed.
- The door may not have had an external key cylinder.

NOTE 3: Doors installed in accordance with Drawing 804-5184141 under previous criteria shall not be reported as a discrepancy.

UNCLASSIFIED

MIL-STD-1680C(SH)
17 March 1993

APPENDIX F

INSPECTION CHECK-OFF SHEETS - Continued

APPENDIX A - SPECIAL INTELLIGENCE SPACE INSTALLATIONS - Continued

(U) 50.2.2.1 Contiguous SI spaces. Where several SI spaces are contiguous to each other or non-SI spaces in one complex, the entire complex may be enclosed by a single physical perimeter barrier conforming to 50.1 and 50.2.1. Access to the complex shall be from a single normal access door conforming to 50.2.2; each compartment within the complex may have a separate access door from within the common physical perimeter barrier which need not be in conformance with 50.2.2. As an alternative to the above, each SI space may have its own physical perimeter barrier and normal access door conforming to 50.2.2. Access from such an SI space to a contiguous SI space may be via a door not in conformance with 50.2.2; however, access from such an SI space to a contiguous non-SI space shall not be installed. Pri-2.

(U) 50.2.3 Emergency exit. For surface ships, the emergency exit shall be fabricated of steel or aluminum plate in consonance with the physical perimeter barrier as specified in 50.2.1 and mounted in a frame braced and welded in place in a manner commensurate with the structural characteristics of the bulkhead, deck or overhead in which it is situated. For surface ships and submarines, the emergency exit shall be operable only from inside the space. Pri-2.

UNCLASSIFIED

MIL-STD-1680C(SH)
17 March 1993

APPENDIX F

INSPECTION CHECK-OFF SHEETS - Continued

APPENDIX A - SPECIAL INTELLIGENCE SPACE INSTALLATIONS - Continued

(U) 50.2.4 Acoustical isolation. Perimeter openings, other than the door, shall be sealed with non-hardening caulking material. Normal speech level within the space shall not be capable of being monitored in adjacent areas, including by way of air handling ducts in adjacent spaces, by unauthorized personnel taking into account the normal ambient noise. Masking equipment (for example, music sound system), if required, shall be installed within the space. Pri-CCA.

- * (U) 50.2.5 Visual isolation. Doors or other openings in the physical perimeter barrier through which classified information may be viewed shall be screened or curtained. This requirement is not applicable to submarines where the visual barrier is in accordance with 5.3.1.8. Pri-1.

UNCLASSIFIED

MIL-STD-1680C(SH)
17 March 1993

APPENDIX F

INSPECTION CHECK-OFF SHEETS - Continued

APPENDIX A - SPECIAL INTELLIGENCE SPACE INSTALLATIONS - Continued

(U) 50.2.6 Security alarm system. The intrusion alarm (see 5.3.1.9) specified for a secure processing center, shall be provided for an SI space. Additionally, primary power for the alarm shall be connected to an emergency lighting panel within the space. Pri-2.

NOTE:

Pertinent features of 5.3.1.9 are:

- Audible and visual alarms at local supervisory position.
- Audible and visual alarms at remote stations.
- Alarm holding condition at local supervisory and remote station.
- Disconnect feature in SI space to cutout remote alarms when space is manned.
- Variable (15-60 seconds) time delay function in SI spaces.
- Disconnect feature in SI space on normal access door when space is manned.
- No disconnect feature on emergency exit sensors.
- Cutout features of alarm sensors provide abnormal visual indication.
- Silencing feature for audible alarm following initial energizing of indicator.
- Switches and sensors in the space.
- Tamper-resistant door/scuttle sensor switches.
- Separate circuit at remote station for loss-of power to intrusion alarm.
- No other alarm circuits will be combined with intrusion alarm when extended to remote station.
- Supervisory feature on remote alarm lines.

NOTE 1: Prior to 1979, a remote feature was not an installation requirement and shall not be reported as a discrepancy if installed under the previous criteria.

NOTE 2: Prior to 1983, the installation criteria did not require the holding feature for a momentary opening, the manned or unmanned switch with its time delay feature, the tamper-resistant door switch and the power failure relay. The absence of such items shall not be reported as a discrepancy if installed under the previous criteria.

UNCLASSIFIED

MIL-STD-1680C(SH)
17 March 1993

APPENDIX F

INSPECTION CHECK-OFF SHEETS - Continued

APPENDIX A - SPECIAL INTELLIGENCE SPACE INSTALLATIONS - Continued

(U) 50.2.7 Passing scuttles. Passing scuttles shall not be installed between an SI space and any other space on the ship. Pri-2.

(U) 50.2.8 Passing windows. Passing windows shall not be installed between an SI space and any other space on the ship. Pri-2.

(U) 50.2.9 Location of cryptographic equipment. On-line and off-line cryptographic equipment and terminal equipment processing SI information shall be located within an SI space. Pri-1.

(U) 50.2.10 Special intelligence cables. A cable containing SI information shall conform to the following:

- a. Where the cable is installed external to an SI space, or restricted area, it shall be visually inspectable throughout its length. If the cable passes through normally locked areas (such as voids, storerooms, and staterooms) or is otherwise uninspectable, it shall be contained in conduit. Pri-2.

UNCLASSIFIED

MIL-STD-1680C(SH)
17 March 1993

APPENDIX F

INSPECTION CHECK-OFF SHEETS - Continued

APPENDIX A - SPECIAL INTELLIGENCE SPACE INSTALLATIONS - Continued

- * (U) b. Splicing the cable shall be avoided wherever possible by using a continuous cable run. If a splice is required, a junction box shall be used. The junction box shall be located with adequate spacing between the box and any other object to allow visual inspection of all surfaces, and the cover tack welded, or the cover shall be secured at opposite ends with combination padlocks conforming to FF-P-110, type DE, Class 2, so that an overt attempt to penetrate the box will be obvious. (Junction boxes installed within the SI space shall be accessible for maintenance or system growth and shall not be tack welded.) Pri-1.

- c. With the exception of 12MC and 82JS, the cable shall not otherwise break out (for example, to a patchboard or terminal board) at any point along the entire run except in an area accredited that level of security. Pri-1.

- d. The cable shall contain only SI circuits. Pri-1.

This requirement is not applicable to surface ships using the LS-653/UYQ-21 or LS-654/UYQ-21(V) as a replacement for the 12MC or to submarines.

UNCLASSIFIED

MIL-STD-1680C(SH)
17 March 1993

APPENDIX F

INSPECTION CHECK-OFF SHEETS - Continued

APPENDIX A - SPECIAL INTELLIGENCE SPACE INSTALLATIONS - Continued

(U) 50.2.11 Secure storage containers. Secure storage containers conforming to AA-F-358 shall be provided for SI material and documents. Pri-2.

NOTE: Containers under this specification have metallic labels affixed to the outside face of the top drawer with the following:

GENERAL SERVICES ADMINISTRATION
APPROVED SECURITY CONTAINER
(manufacturer's name)

Also, on the side of the drawer with the locking mechanism, there will be a metallic label indicating the class designation and the applicable federal specification.

Special intelligence security storage containers shall be welded in place, or otherwise secured to a foundation for safety and to prevent rapid removal. Pri-3.

For submarines, a designated storage space for equipment and bulk documents not stowed in the special intelligence security containers shall be equipped with a tamper-proof hasp and combination padlock conforming to FF-P-110, type DE, class 1. Pri-1.

UNCLASSIFIED

MIL-STD-1680C(SH)
17 March 1993

APPENDIX F

INSPECTION CHECK-OFF SHEETS - Continued

APPENDIX A - SPECIAL INTELLIGENCE SPACE INSTALLATIONS - Continued

- * (U) 50.2.12 Isolation of SI classified information processing systems. The SI classified information processing system shall not interconnect to any non-SI classified information processing systems internal or external to the space except under one or more of the following conditions: Pri-CCA.
 - a. In SI intercommunication announcing systems, as specified in 50.2.15.
 - b. In SI sound powered telephone systems, as specified in 50.2.14.1.
 - c. To another SI accredited space except for circuits covered by a. and b. above.
 - d. Via a disconnect function (for example, switch matrix, disconnect switch, sanitizing switch).
 - e. In a parallel data circuit wherein the signal line flow of data is from a non-SI area to the SI space (excluding control lines of the circuit that flow in a reverse direction).

UNCLASSIFIED

MIL-STD-1680C(SH)
17 March 1993

APPENDIX F

INSPECTION CHECK-OFF SHEETS - Continued

APPENDIX A - SPECIAL INTELLIGENCE SPACE INSTALLATIONS - Continued

* (U) 50.2.13 Telephones. All telephones, except the TA-866() of AN/STC-1 or AN/STC-2 and the STU-III, shall be provided approved and verifiable on-hook audio security. There are two acceptable methods authorized for providing this security. Neither approach is regarded as being better than the other: Pri-2.

- a. Use of a Telephone Security Group (TSG) type-accepted or type-approved telephone that possess security properties which are intrinsic to the telephone itself. Any TSG type-accepted or type-approved telephone listed in DIAM-50-3 (or its successor document) can be used within an SI space without additional isolation or disconnect measures. Some TSG type-approved telephones may require ringer isolation.

- b. Isolation of telephones from uncontrolled lines. Line isolation may be achieved by the use of either TSG approved disconnect devices or a computerized telephone system (CTS) installed in accordance with TSG guidance. TSG approved isolators, disconnects and CTS installation guidance can be found in DIAM 50-3 (or its successor document).

(U) 50.2.14 Sound powered telephones. Sound powered telephones shall be equipped with a positive disconnect device (such as a plug or jack). Pri-2.

Call signal station type IC/D, when used, shall be modified as specified in 5.3.2. Pri-1.

UNCLASSIFIED

MIL-STD-1680C(SH)
17 March 1993

APPENDIX F

INSPECTION CHECK-OFF SHEETS - Continued

APPENDIX A - SPECIAL INTELLIGENCE SPACE INSTALLATIONS - Continued

(U) 50.2.14.1 Special intelligence sound powered telephone system. A sound powered telephone system used to process SI information (82JS), where installed, shall be in compliance with the following: Pri-1.

- a. The telephone cable shall not break out to jackboxes, switchboards or to telephone sets other than at the designated stations. The telephone cable shall not be shared with any circuit other than call or signal systems associated with this circuit.

- b. Be equipped with a selector switch, located at the controlling station cable of:
 - (1) disconnecting all stations,

 - (2) selecting any one station and disconnecting the remaining stations,

 - (3) a parallel connection to all stations.

- c. Other stations that are accredited as an SI space not equipped with the selector switch in item b. shall have a positive disconnect device in the telephone line.

- d. Sound powered telephone sets co-located in a space with this system, and not used for passing SI information, shall have a sign posted that these telephone sets are not for passing classified information.

UNCLASSIFIED

MIL-STD-1680C(SH)
17 March 1993

APPENDIX F

INSPECTION CHECK-OFF SHEETS - Continued

APPENDIX A - SPECIAL INTELLIGENCE SPACE INSTALLATIONS - Continued

(U) e. A call or signal system should be provided. Call signal station, Type IC/D, when used for circuit 82JS shall be modified as specified in 5.3.2.

(U) 50.2.15 Special intelligence intercommunication announcing system. An intercommunication type announcing system processing SI information which connects to or passes through areas outside the SI space shall use the 12MC system and be installed in accordance with Drawing 815-1853315. Pri-1.

The switch matrix panel shall be located within one of the SI spaces. Pri-2.

Cables serving this system shall be treated as SI cables (see 50.2.10) and shall be marked with a "L/" designator on ships with a RED high level signal distribution system. Pri-2.

Primary a.c. power shall be provided from a vital or emergency lighting circuit. Pri-3.

UNCLASSIFIED

MIL-STD-1680C(SH)
17 March 1993

APPENDIX F

INSPECTION CHECK-OFF SHEETS - Continued

APPENDIX A - SPECIAL INTELLIGENCE SPACE INSTALLATIONS - Continued

- * (U) 50.2.15.1 LS-653 or LS-654()/UYQ-21 in lieu of 12MC. The LS-653 or LS-654()/UYQ-21(V) with the ON-201/UYQ-21(V) is approved for use as a replacement for the 12MC in ships with a single SI space. The ON-201/UYQ-21(V) may be installed in a general service space which is designated a secure remote area. The SI cable criteria is not applicable to cables between the LS-653 or LS-654()/UYQ-21 and the ON-201/UYQ-21(V).

Note: Not an FTA inspection item. This is a design information item.

- * (U) 50.2.15.2 Supporting intercommunication announcing systems. Intercommunication type announcing systems installed within an SI space which do not process classified information shall be designed or modified to provide the following physical or electrical security safeguards:

- a. Operational mode of the unit installed within the SI space shall limit operations to push-to-talk mode only. Pri-3.

- b. Receive elements shall be equipped with a local amplifier as a buffer to prevent loudspeakers or earphones from functioning as microphones. Pri-2.

UNCLASSIFIED

MIL-STD-1680C(SH)
17 March 1993

APPENDIX F

INSPECTION CHECK-OFF SHEETS - Continued

APPENDIX A - SPECIAL INTELLIGENCE SPACE INSTALLATIONS - Continued

(U) c. Except as specified in 50.1.5, radio transmission capability for plain language radio telephone (excluding secure voice) shall not be connected. Cable conductors assigned to the transmission of plain language radio telephones shall be connected to ground at each end of the cable. Pri-1.

* d. Modified equipment shall have a tag affixed to the front or top, as appropriate, stating, "MODIFIED IN ACCORDANCE WITH MIL-STD-1680()." Additionally, the unit shall have a warning sign posted on it stating, "NOT FOR PASSING CLASSIFIED INFORMATION." Pri-3.

(U) 50.2.16 Commercial intercommunication equipment. Commercial intercommunication equipment that is not included in NAVSEA approved drawings shall not be installed in an SI space. Pri-2.

(U) 50.2.17 General announcing systems. General announcing system loudspeakers shall have an audio amplifier in the signal line to the loudspeaker to serve as a buffer. The amplifier and the output signal lines shall be installed within the SI space. Pri-2.

UNCLASSIFIED

MIL-STD-1680C(SH)
17 March 1993

APPENDIX F

INSPECTION CHECK-OFF SHEETS - Continued

APPENDIX A - SPECIAL INTELLIGENCE SPACE INSTALLATIONS - Continued

- * (U) 50.2.21 Emergency power. An SI space shall have emergency power sufficient to operate destruction equipment, the alarm system, access control devices, and to provide emergency lighting. Emergency power shall be obtained from the nearest available emergency lighting panel or switchboard. Pri-2.

NOTE: Prior to 1979, the installation criteria did not require emergency power for these items; such items that are not connected to emergency power shall not be reported as a discrepancy if installed under the previous criteria.

(U) 50.3.1 Contingency space perimeter barrier. The physical perimeter barrier of the contingency SI space requires no special construction. The area shall be capable of being "sealed" so as to prevent visual or aural penetration during all operations. Pri-2.

(U) 50.3.2 Contingency space accesses. No special construction requirements are applicable for accesses to contingency SI spaces. Doors shall be capable of being secured from the inside. Pri-3.

UNCLASSIFIED

MIL-STD-1680C(SH)
17 March 1993

APPENDIX F

INSPECTION CHECK-OFF SHEETS - Continued

APPENDIX A - SPECIAL INTELLIGENCE SPACE INSTALLATIONS - Continued

(U) 50.3.3 Contingency space access marking. Provisions shall be made for posting a temporary sign which reads "RESTRICTED AREA - NO ADMITTANCE BEYOND THIS POINT." Pri-3.

Note: Prior to 1988, sign read "RESTRICTED AREA-KEEP OUT-AUTHORIZED PERSONNEL ONLY." Signs installed prior to this date shall not be reported as a discrepancy.

(U) 50.3.4 Contingency space secure storage containers. When SI material or documents are to be stored in the space, a secure storage container conforming to AA-F-358 shall be provided. Security storage containers shall be welded in place, or otherwise secured to a foundation for safety and to prevent rapid removal. Pri-CCA.

(NOTE: Containers under this specification have metallic labels affixed to the outside face of the top drawer with the following:

GENERAL SERVICES ADMINISTRATION
APPROVED SECURITY CONTAINER
(manufacturer's name)

Also, on the side of the drawer with the locking mechanism, there will be a metallic label indicating the class designation and the applicable federal specification.)

UNCLASSIFIED

MIL-STD-1680C(SH)

17 March 1993

APPENDIX F

INSPECTION CHECK-OFF SHEETS - Continued

APPENDIX A - SPECIAL INTELLIGENCE SPACE INSTALLATIONS - Continued

- (U) c. Doors, scuttles, vents, louvers or other openings in the perimeter which permit aural or visual penetration of the interior shall be screened, curtained or blocked.

- d. An efficient and secure means of destruction of classified material shall be readily available in the space or nearby in general service spaces.

- * e. Cryptographic equipment processing SI information shall be located in the SI space, or if located in a secure processing center other than that accredited for SI shall be electrically configured so as not to be compatible with the classified information processing system of that secure processing center.

- f. A filing cabinet for stowage of classified material.

- * g. Telephone installations shall be as specified in 50.2.13.

- h. Sound powered telephone installations shall be as specified in 50.2.14 and 50.2.14.1.

Additional criteria may be imposed as required on a case-by-case basis.

UNCLASSIFIED

MIL-STD-1680C(SH)
17 March 1993

APPENDIX F

INSPECTION CHECK-OFF SHEETS - Continued

APPENDIX B - CCTV

- * (U) 50.1.1.1 RED CCTV video. A RED CCTV system shall be a baseband video system throughout the distribution network. Modulated carrier systems shall not be installed or utilized for RED CCTV. Pri-1.

- * (U) 50.1.1.2 RED CCTV audio. A RED CCTV audio distribution system shall be a balanced system. The audio level shall not exceed 0 dB as referred to 1 milliwatt (dBm), with the exception of the audio between an amplifier and loudspeaker. A RED CCTV audio system shall be separate from BLACK CCTV audio distribution systems. Pri-3.

- (U) 50.1.2 RED and BLACK CCTV electrical signal distribution system interfacing. RED and BLACK CCTV shall be interfaced in the electrical signal distribution system only by (see Figure 21, Appendix I): Pri-1.
 - a. Routing switches, as specified herein (see 50.1.7.2).

 - b. TV system selector switches, as specified herein (see 30.15 and 50.1.6).

UNCLASSIFIED

MIL-STD-1680C(SH)
17 March 1993

APPENDIX F

INSPECTION CHECK-OFF SHEETS - Continued

APPENDIX B - CCTV

(U) 50.1.3 RED CCTV equipment power connection. Each RED baseband CCTV equipment may be permanently connected to a BLACK power panel, or plugged into a convenience outlet wired to BLACK power. Pri-2.

NOTE: Prior to 1984 RED CCTV required connection to RED primary power. Those installations will not be reported as a discrepancy if installed under the previous standard.

(U) 50.1.4 Rotary or tone/pulse dial analog telephone lines. Rotary or tone/pulse dial analog telephones which have a capability for connection to shore lines, and located in the same space as a non-SPAWAR TEMPEST-approved RED CCTV equipment, shall have the telephone line filtered. Pri-1.

The filter shall provide 100 Db of attenuation within the stopband of 150 kHz to 1 GHz. The filter shall be installed within the room(s) containing the system components. Pri-2.

UNCLASSIFIED

MIL-STD-1680C(SH)
17 March 1993

APPENDIX F

INSPECTION CHECK-OFF SHEETS - Continued

APPENDIX B - CCTV - Continued

(U) The filter is not required if the telephone is a digital telephone such as the STU-III, STC-1 or STC-2.
Pri-2.

NOTE: Prior to 1976, the installation criteria did not specify filter location and attenuation characteristics; such items shall not be reported as a discrepancy if installed under the previous criteria.

* (U) 50.1.5 Equipment separation. RED CCTV systems shall be separated a minimum of 3 feet from BLACK send Osignal processors such as the following: Pri-2.

a. Radio transmitters and transceivers.

b. Modems and other modulating devices, such as a send AN/UCC-1(V) and CV-2460/SGC.

* c. Remote units of a p/c secure voice system not having filtered transmit audio lines.

UNCLASSIFIED

MIL-STD-1680C(SH)

17 March 1993

APPENDIX F

INSPECTION CHECK-OFF SHEETS - Continued

APPENDIX B - CCTV - Continued

(U) d. Transfer switchboards having a direct connection to radio transmitters or transceivers, such as transmitter transfer, receiver transfer, frequency selection transfer, data transfer and FSK/RFCS.

e. A BLACK TTY equipment with a send capability.

f. Control units used with radio transmitters or transceivers, such as C-1004() /SG and C-9351/WSC-3(V).

* (U) 50.1.6 Television receivers. Television receivers, located in a secure video control or viewing space shall only be connected to an antenna as follows: Pri-1.

a. Television receivers used for reception of broadcast signals shall be connected to an antenna only via an antenna distribution system which includes receive RF amplifiers.

UNCLASSIFIED

MIL-STD-1680C(SH)
17 March 1993

APPENDIX F

INSPECTION CHECK-OFF SHEETS - Continued

APPENDIX B - CCTV - Continued

- (U) b. When television receivers are shared in viewing a RED CCTV signal and a BLACK television or CCTV signal in an existing installation, a TV system selector switch (for example, coaxial switch) shall provide receiver selection of the RED or BLACK signal. Such switches shall have a minimum isolation of 80 dB in the stopband of 150 kHz to 1 GHz between RED and BLACK inputs to the switch. When receiving a RED baseband input the receiver shall conform to the requirements of 50.1.7.3.

BLACK television receivers connected directly to an antenna shall not be located in the same room with a RED CCTV system. Pri-1.

(U) 50.1.7.1 Unused video terminations. Unused signal input and output connections shall be terminated in their appropriate impedance. Pri-1.

UNCLASSIFIED

MIL-STD-1680C(SH)
17 March 1993

APPENDIX F

INSPECTION CHECK-OFF SHEETS - Continued

APPENDIX B - CCTV - Continued

- * (U) 50.1.7.2 Routing switcher and production switcher. Routing switchers and production switchers which have both RED and BLACK inputs shall provide 80 dB isolation in the stopband of 300 to 10,000 Hz and 50 kHz to 500 MHz between inputs. If the routing switcher or production switcher cannot provide the 80 dB isolation between inputs, isolation amplifiers may be used in the BLACK input line(s) to achieve the necessary added isolation for a minimum aggregate of 80 dB. Amplifiers used for this purpose become part of the RED system and shall be located within the secure video control space.

NOTE: Not an FTA inspection item. This is a design information item.

(U) 50.1.7.3 Television receivers used with baseband video systems. The TV receivers, modified for a video input, and processing secure video information, shall be additionally modified by disabling the RF and IF strips or the tuner and local oscillator. Pri-1.

(U) 50.1.7.4 RED baseband video outputs. No output shall exist from a RED baseband video system as an input to any BLACK system. Pri-1.

UNCLASSIFIED

MIL-STD-1680C(SH)
17 March 1993

APPENDIX F

INSPECTION CHECK-OFF SHEETS - Continued

APPENDIX B - CCTV - Continued

- * (U) 50.1.8 Closed circuit television audio and control cables. RED CCTV cables shall be shielded. RED CCTV audio cables shall be twisted-pair, individually-shielded or overall shielded. RED CCTV audio cables may include RED CCTV control lines. Cables containing only RED CCTV control lines shall be single or multi-conductor with overall shielding. Pri-2.

Cables containing only RED CCTV control lines shall be single or multi-conductor with overall shielding. Pri-3.

(U) 50.1.9 Closed circuit television cable separation. For purposes of cable separation (see 5.1.10.12 through 5.1.10.15), a RED CCTV audio distribution system is low level when balanced and the audio levels in the electrical signal distribution system do not exceed 0 dBm (1 milliwatt into a 600-ohm load). Video and control cables that are part of a baseband video system shall be considered as low level cables. Cables that are part of a RED modulated-carrier system shall be considered as RED high level cables. Pri-1.

UNCLASSIFIED

MIL-STD-1680C(SH)
17 March 1993

APPENDIX F

INSPECTION CHECK-OFF SHEETS - Continued

APPENDIX B - CCTV - Continued

(U) 50.1.10 Closed circuit television bonding. The various units of the CCTV system shall be bonded to ground as specified herein.

NOTE: Inspected under 50.1.10.1 and 50.1.10.2.

(U) 50.1.10.1 Bonding of CCTV equipment. RED CCTV equipment shall be bonded to ground using any of the following methods which are most practical and in conformance to the other requirements of the CCTV system: Pri-1.

- a. A class B bond between the equipment chassis or metallic cabinet enclosure and a ground-potential support frame or foundation (see 5.2.14.2).
- b. A class C bond strap for equipment in a non-metallic enclosure (see 5.2.14.3, 5.2.14.4 and 5.2.14.5). The bond strap shall be connected between the equipment chassis and ground.
- c. As prescribed by the manufacturer.

UNCLASSIFIED

MIL-STD-1680C(SH)
17 March 1993

APPENDIX F

INSPECTION CHECK-OFF SHEETS - Continued

APPENDIX B - CCTV - Continued

(U) d. For portable equipment only (for example, camera) via the third-wire ground in the power cable or a ground conductor in a control cable.

(U) 50.1.10.2 Bonding of CCTV cable shields. The outer of RED CCTV cables shall be bonded to ground at both ends. BLACK CCTV which terminate in a RED CCTV equipment (for example, routing switchers) shall have the outer shield bonded to ground at both ends. Pri-2

(U) 50.2.1 Equipment location. Video equipment processing secure video or audio information, or both, shall be located in a secure vide control space or a secure video viewing space. Pri-2.

(U) 50.2.2 Closed circuit television audio amplifier or speaker control. Each audio amplifier or loudspeaker, processing the audio associated with a secure video system, shall be capable of being locally adjusted in audio volume level and disconnected from the audio signal line. Pri-2.

UNCLASSIFIED

MIL-STD-1680C(SH)
17 March 1993

APPENDIX F

INSPECTION CHECK-OFF SHEETS - Continued

APPENDIX B - CCTV - Continued

- * (U) 50.2.3 Closed circuit television RED coaxial or triaxial continuous cable runs. RED CCTV coaxial and triaxial cables outside of a secure video control space, secure video viewing space, or restricted area shall be run in continuous lengths with no in-line connectors or splices. Bulkhead adapters, if used, shall be totally within the above spaces. Pri 3.

- * (U) 50.2.4 Rotary or tone/pulse dial telephones. Rotary or tone/pulse dial telephones which have a capability for connection to shore lines, and located in the same space as RED CCTV equipment with a loudspeaker, shall have a push-to-operate feature or a push-to-talk feature and buffer amplifier in the receive element. Pri-3.

The telephone instrument shall be located as far away from the loudspeaker as practical. Pri-3.

NOTE: Prior to 1976, the installation criteria did not specify these restrictions on telephones; such items shall not be reported as a discrepancy if installed under the previous criteria.

UNCLASSIFIED

MIL-STD-1680C(SH)
17 March 1993

APPENDIX F

INSPECTION CHECK-OFF SHEETS - Continued

APPENDIX B - CCTV - Continued

(U) 50.2.5 Closed circuit television video or audio disconnect to viewing spaces. A positive means of disconnecting the RED video and audio to a secure video viewing space shall be provided in the secure video control space. The routing switcher is acceptable for this function. Pri-2.

(U) 50.2.6 Special intelligence lock-out. A lock-out device shall be provided in the control apparatus for selective distribution of SI video and audio information. The lock-out device shall, by logic, electrical or mechanical means, be capable of controlling which secure video viewing space can select an SI output from the routing switcher. The lock-out device shall be located in the secure video control space. Pri-1.

(U) 50.2.7 Closed circuit television interconnection safeguards. Facilities may exist for the interconnection of BLACK video or audio signals in a RED CCTV system. Such facilities shall provide the necessary safeguards against inadvertent connection of RED CCTV signal into a BLACK TV or CCTV system. A routing switcher, TV system selector switch or any other unit which has both RED and BLACK cables connected to it shall provide, as a minimum, that RED and BLACK chassis connectors and cables be marked with a symbol designator or functional designator to indicate proper termination. Pri-1.

UNCLASSIFIED

MIL-STD-1680C(SH)
17 March 1993

APPENDIX F

INSPECTION CHECK-OFF SHEETS - Continued

APPENDIX B - CCTV - Continued

(U) 50.2.8 Video tape secure storage container. When the RED CCTV system includes a video tape recorder and processes SI information, a security container conforming to AA-F-358 capable of storing 25 hours of video tape shall be installed in the secure video control space. The security storage container shall be welded in place, or otherwise secured to a foundation for safety and to prevent rapid removal. Pri-3

(NOTE: Containers under this specification have metallic labels affixed to the outside face of the top drawer with the following:

GENERAL SERVICES ADMINISTRATION
APPROVED SECURITY CONTAINER
(manufacturer's name)

Also, on the side of the drawer with the locking mechanism, there will be a metallic label indicating the class designation and the applicable federal specification.)

(U) 50.2.9 Closed circuit television cable designator. RED CCTV cables shall be marked in accordance with paragraph 5.3.1.16.1. Pri-2.

MIL-STD-1680C(SH)
17 March 1993

APPENDIX F

INSPECTION CHECK-OFF SHEETS - Continued

APPENDIX C - FIBER OPTIC DISTRIBUTION SYSTEMS

(U) NOTE: See Appendix C. Pri-CCA.

UNCLASSIFIED

MIL-STD-1680C(SH)

17 March 1993

APPENDIX F

INSPECTION CHECK-OFF SHEETS - Continued

APPENDIX E - COMBAT SYSTEM SHIP LAND BASED TEST SITE

Notes:

(U) 1. Any reference to metallic hull surface ships and new construction ships in the basic document shall be understood to refer to the SLBTS building structure.

(U) 2. A ground bus shall extend through the SLBTS to the extent required for detailed bonding requirements. The ground bus shall be connected to the structural ground. The structural ground is assumed to have a grounding electrode to a continuous metallic underground water system or to an appropriate buried metal ground point.

(U) 3. See 60.2.3, Appendix E, concerning priority correction of discrepancies.

(U) 50.2 Approved cables. Requirement 5.2.11 is modified so that RED cables having special characteristics (for example, double shielding) that do not meet the requirements of MIL-C-17, MIL-C-915, MIL-C-24640 or MIL-C-24643 shall be submitted to NAVSEA (Code 03K222) with full design characteristics prior to installation.

(U) 50.3 Normal access doors. Modify 5.3.1.3.a. to specify standard building doors rather than the metal joiner door.

UNCLASSIFIED

MIL-STD-1680C(SH)
17 March 1993

APPENDIX F

INSPECTION CHECK-OFF SHEETS - Continued

APPENDIX H - BOATS AND CRAFT

- * (U) 50.1.1 RED and BLACK electrical signal distribution system interfacing. RED and BLACK electrical signal distribution systems shall be electrically interfaced only by: Pri-1.
 - a. SPAWAR TEMPEST-approved isolation devices.

 - b. Cryptographic equipment.

 - c. SPAWAR TEMPEST-approved switches used for secure/non-secure purposes.

- * (U) 50.1.2 Combined radio and secure systems. Combined radio and secure systems shall be installed in boats and craft in accordance with the following: Pri-1.
 - a. Where a radio transceiver and secure voice processing equipment share common circuitry, such as power supplies, by system design, such system shall be SPAWAR TEMPEST-approved prior to installation.

UNCLASSIFIED

MIL-STD-1680C(SH)
17 March 1993

APPENDIX F

INSPECTION CHECK-OFF SHEETS - Continued

APPENDIX H - BOATS AND CRAFT

- (U) b. Where a unit of a radio transmitter performs the function of switching between plain and cipher voice, the total system of radio and RED processing equipment shall be TEMPEST approved prior to installation.

- * (U) 50.1.3 Primary power. SPAWAR TEMPEST approved equipment shall be connected to BLACK power. Pri-3.

- * (U) 50.1.3.1 RED Power. RED power shall be derived from power filters that provide 100 dB of attenuation within the stopband of 14 kHz to 1 GHz. They shall be installed as close as practical to the equipment requiring RED power. Pri-3.

- * (U) 50.1.4 Cable. Cabling in the secure processing system shall comply with the following:
 - a. RED cable shall be shielded. Pri-1.

UNCLASSIFIED

MIL-STD-1680C(SH)
17 March 1993

APPENDIX F

INSPECTION CHECK-OFF SHEETS - Continued

APPENDIX H - BOATS AND CRAFT

- (U) b. RED cables containing conductors connected to a RED low level electrical signal distribution system may also contain conductors connected to the BLACK electrical signal distribution system provided the RED conductors are individually shielded, as balanced twisted pairs or overall shielded from the BLACK conductors. Pri-1.
- c. RED signal and control lines shall be composed of twisted pairs of conductors, and shall not use the shield/armor of the cable or the boat/craft hull for the electrical return path. Coaxial cables are excluded from this requirement. Pri-2.
- d. Cables and conductors serving secure voice processing equipment shall be isolated in the following manner:
Pri-CCA.
- (1) Transmit and receive audio lines shall be balanced twisted pairs with each pair non-ferrous shielded, and the shields insulated from each other. An exception to this may be where the transmit pair and associated transmit control lines are contained in one cable with an overall non-ferrous shield, and the associated receive audio is contained in a separate twisted shielded pair cable.

UNCLASSIFIED

MIL-STD-1680C(SH)
17 March 1993

APPENDIX F

INSPECTION CHECK-OFF SHEETS - Continued

APPENDIX H - BOATS AND CRAFT

- (U) (2) When a multi-circuit cable is used, as a minimum, each transmit and receive audio twisted pair shall be non-ferrous shielded with all shields insulated and an overall insulating sheath.
- (3) In a cable containing only one secure voice send/receive circuit and not exceeding 25 feet in length, the cable may have an overall non-ferrous shield, and an overall insulating sheath.
- e. Junction boxes may be used as an intermediate connection point for cables containing both RED and BLACK circuits. Cables and conductors within a shared junction box shall conform to the following: Pri-1.
- (1) The lay of the twisted pair shall be retained within the box up to the point of termination on the terminal strip.
- (2) The shield over the twisted pair shall be retained within the box up to the point of termination on the terminal strip.
- (3) The shield shall be bonded to ground at the terminal strip.

UNCLASSIFIED

MIL-STD-1680C(SH)
17 March 1993

APPENDIX F

INSPECTION CHECK-OFF SHEETS - Continued

APPENDIX H - BOATS AND CRAFT

(U) (4) Conductors within the box shall be as short as possible, yet long enough to reach any terminal connection in the box.

* (U) 50.1.5 Secure voice signal lines. Secure voice signal lines shall operate as a 600-ohm balanced system.

Note: This is not an FTA inspection item. This is a design information item.

* (U) 50.1.6 Bonding. Cryptographic equipment, RED electrical processing equipment, RED cable shields and armor, and power filters shall be bonded to ground. Spare conductors in RED cables shall be connected to ground at both ends. Pri-1.

* (U) 50.2.1 Cryptographic equipment modification. Modification of cryptographic equipment shall not be made without proper authority. Authorized modifications to a cryptographic equipment are promulgated as changes to the KAM maintenance manual for that cryptographic equipment. Pri-1.

UNCLASSIFIED

MIL-STD-1680C(SH)
17 March 1993

APPENDIX F

INSPECTION CHECK-OFF SHEETS - Continued

APPENDIX H - BOATS AND CRAFT

* (U) 50.2.2 Cryptographic equipment cables. The cables supplied with cryptographic equipment are often of specific length, wire gauge or shielding characteristics, and are part of the total system design. The fully assembled cables shall not be modified or reduced in length, unless promulgated as part of an authorized change. Pri-2.

* (U) 50.2.3 Bonding methods. The various parts, units and assemblies of a RED electrical processing system shall be bonded to ground as specified herein. General bonding requirements for electromagnetic compatibility (EMC) and safety shall comply with MIL-STD-1310 to the extent such requirements do not conflict with the requirements herein. One bonding method per equipment may suffice as long as it meets the minimum bonding and grounding requirements of personnel safety, EMC and TEMPEST. In non-metallic hull boats and craft, the third wire or safety ground shall be an acceptable substitute for any bond strap specified herein.

Note: This is not an FTA inspection item. This is a design information item.

UNCLASSIFIED

MIL-STD-1680C(SH)
17 March 1993

APPENDIX F

INSPECTION CHECK-OFF SHEETS - Continued

APPENDIX H - BOATS AND CRAFT

* (U) 50.2.3.1 Bonding via mounting hardware. Equipment, cabinets, consoles and junction boxes containing RED circuits shall be bonded to ground utilizing the available mounting holes provided, unless otherwise directed. Bolts, nuts and washers shall be CRES Series 300 using a size corresponding to the existing mounting holes; if holes must be drilled, minimum nominal diameter shall be for 0.25-inch hardware. The bonding contact area shall be cleaned to bare metal. A class 3 chemical coating, i.e., anodizing, applied in accordance with MIL-C-5541 is a conductive coating and shall not be removed. Where feasible, a bond may be accomplished via a weld, braze or bond strap in addition to, or instead of, the mounting hardware. The above is predicated on the fact that such units are installed in, or on metallic enclosures or foundations. The enclosure or foundation shall be a metallic extension of the hull or have an electrical ground connection to the electrical ground bus. Pri-2.

* (U) 50.2.3.2 Solid bond straps. Solid bond strap material shall be copper, at least 0.020-inches thick, and at least 3/4-inch wide. The length of the bond strap shall not be greater than 5 times the width and shall be as short as practical. Punch or cut out mounting holes for 5/16-inch hardware. Zinc plating or other protective coating shall be used on bond straps to prolong the effective life of the strap and reduce galvanic action between dissimilar metals. Bolts, nuts and washers shall be CRES Series 300. Bond straps shall be installed in locations that permit rapid inspection and replacement. Bonds shall in no way interfere with internal parts of the equipment or the movement of resilient mounts. Ground studs built into equipment enclosures shall be utilized in preference to drilling a new hole, provided that the ground stud location on the enclosure will not increase the length of the bond strap beyond normal tolerances. Pri-2.

UNCLASSIFIED

MIL-STD-1680C(SH)
17 March 1993

APPENDIX F

INSPECTION CHECK-OFF SHEETS - Continued

APPENDIX H - BOATS AND CRAFT

(U) The bonding contact area shall be cleaned to bare metal. Cleaned areas and threaded hardware shall be coated with an anti-seize compound, conforming to MIL-T-22361 prior to the installation of the bond strap to prolong the effective life of the bond. A class 3 chemical coating, i.e., anodizing, applied in accordance with MIL-C-5541 is a conductive coating and shall not be removed. Pri-1.

* (U) 50.2.3.3 Cryptographic equipment. Cryptographic equipment and cryptographic ancillary units (for example, TSEC nomenclature equipment) shall be bonded to ground utilizing the available mounting holes and hardware provided, except as indicated herein. Pri-1.

a. TSEC/KY-58. The TSEC/KY-58 is bonded to the HYX-58/TSEC via the mechanical fasteners. The HYX-58/TSEC mounted in MT-4841(V)/U is bonded to the unit with internal copper fingered leaf springs, and does not require additional bonding.

b. TSEC/KYV-5. The KYV-5 has an inherent class B bond to the AN/USC-43(V) Basic Terminal Unit (BTU). The BTU shall be bonded to ground with a class C solid bond strap between the ground stud on the BTU and the foundation.

c. TSEC/KI-1 (see 5.2.14.13.c.)

UNCLASSIFIED

MIL-STD-1680C(SH)
17 March 1993

APPENDIX F

INSPECTION CHECK-OFF SHEETS - Continued

APPENDIX H - BOATS AND CRAFT

- * (U) 50.2.3.4 Power filters. The case of a power filter, if not bonded to ground with the mounting hardware, shall be bonded to ground with a solid class C bond strap. Pri-1.

- * (U) 50.2.3.5 Resilient mounted equipment. Resilient mounted equipment shall be bonded to ground with a class C bond strap. Flexible bond straps may be used on equipment having resilient mounts which allow multidirectional excursions that may damage solid class C bond straps. Pri-1.

- * (U) 50.2.3.6 Bonding of shields and armor on RED cables. RED cables shall have the shields (and armor, if applicable) of the cable bonded to ground at both ends. Cable shields for secure voice circuit terminations on barrier terminal strips, as in 50.1.4.f, shall be bonded to ground within the enclosure at the terminal strip. Other cable shields shall be bonded to ground within an enclosure at a terminal strip or at the point of entry to the enclosure. Armor shall be bonded to ground at the entry to the enclosure. Pri-1.

UNCLASSIFIED

MIL-STD-1680C(SH)
17 March 1993

APPENDIX F

INSPECTION CHECK-OFF SHEETS - Continued

APPENDIX H - BOATS AND CRAFT

- * (U) 50.2.3.7 Unused and spare conductors. Unused or spare conductors and shields of RED cables shall be bonded to ground at both ends. Such conductors shall have sufficient length to be connected to any of the terminations. Pri-2.

- * (U) 50.3.1 Security spaces. Secure processing centers, secure remote areas, remote areas and exposed remote stations are not elements of the secure processing system in boats and craft. Cryptographic equipment and RED processing equipment shall be installed in enclosed stations or unprotected stations as defined herein. Pri-3.

- * (U) 50.3.2 Location of cryptographic and RED processing equipment. Cryptographic and RED processing equipment shall be installed in accordance with the following order of preference, dependent upon size and configuration of the boat or craft:
Pri-1.

UNCLASSIFIED

MIL-STD-1680C(SH)
17 March 1993

APPENDIX F

INSPECTION CHECK-OFF SHEETS - Continued

APPENDIX H - BOATS AND CRAFT

- (U) a. Within an enclosed station that has a deck, overhead and complete bulkheads, with access/exits constructed to preclude access to, or viewing of, the interior. There shall be only one access door. This door shall be equipped with locking devices, and as a minimum shall be a lock hasp with a medium security padlock. Emergency exits shall be operable only from inside the space. An electronic equipment room, a radio room or a secure equipment room may be an enclosed station.
- b. Within an enclosed station not able to meet the perimeter requirements of (a) above, such as a pilot house. A secure storage container shall be provided for COMSEC paper material, equipment and other classified documents.
- c. At an unprotected station that will obviously have someone in attendance, such as the coxswain or pilot, while cryptographic equipment is installed. The installation shall be electrically and physically configured so that the cryptographic equipment can be easily removed from its normal foundation or housing to a more secure storage. A removable weighted container suitable for the storage of classified documents with minimum dimensions of 11.5" X 9" X 3" shall be provided. The container shall be fastened to the structure of the craft by lanyard or other equally secure method. An open conning station or coxswains station may be an unprotected station.

UNCLASSIFIED

MIL-STD-1680C(SH)
17 March 1993

APPENDIX F

INSPECTION CHECK-OFF SHEETS - Continued

APPENDIX H - BOATS AND CRAFT

- * (U) 50.3.3 RED and BLACK system sharing. RED and BLACK electrical distribution systems may share the same processing equipment when specified in NAVSEA drawings or documents to meet operational requirements. A transfer, patching or switching system used to connect a position alternately to a RED or BLACK system shall: Pri-2.
- a. Have clearly identified controls with a visual status indication at the operating position or equipment terminal.
 - b. Be secure against accidental or unauthorized connection of circuit, channel, or position to the secure or non-secure positions.
 - c. Be impossible to by-pass unintentionally.
 - d. For semi-automatic or automatic systems where manual manipulation is not employed, provide fail-safe operation by circuit lock-up or positive diversion to a secure system in the event of equipment malfunction.
 - e. Be considered a part of the secure system to which it will be connected and be afforded the same physical security.

UNCLASSIFIED

MIL-STD-1680C(SH)
17 March 1993

APPENDIX F

INSPECTION CHECK-OFF SHEETS - Continued

APPENDIX J - MICRO/MINI COMPUTER SYSTEM

- * (U) 50.1.1 Primary power. If the computer system is not listed in Appendix D, 50.1, 50.2 or 50.3, it shall be installed on RED primary power if RED power is available within the space. If not, the system may be installed on BLACK power, however the computer system shall not be powered from the same circuit breaker panel that powers BLACK modems or R.F. transmitters. This requirement is not applicable to nonmetallic hull ships. Pri-CCA.

- * (U) 50.1.2 Shielded cables. Locally fabricated RED shielded cables shall be in accordance with 5.2.11. Cables interconnecting the computer components which are provided by the manufacturer should be shielded if available; otherwise, the unshielded cables may be used without modification. Pri-CCA.

- * (U) 50.1.3 Grounding. The power cable shall have a third wire or safety ground. No other ground is required for the system unless the equipment has provisions for installation of a bond strap, in which case a bond strap shall be installed. Pri-1.

- * (U) 50.1.4 Cable grounding. Locally fabricated RED shielded cable shall be bonded to ground in accordance with paragraph 5.2.14.19. Pri-2.

- * (U) 50.1.5 Interconnection. Computer systems interconnected to other CLIPS shall be installed in accordance with this standard (See 5.1.1 and 5.3.5.1.1). Pri-1.

UNCLASSIFIED

MIL-STD-1680C(SH)
17 March 1993

APPENDIX F

INSPECTION CHECK-OFF SHEETS - Continued

APPENDIX J - MICRO/MINI COMPUTER SYSTEM

- * (U) 50.1.6 Electrical Perimeter Barrier. The compartment in which the computer system is installed shall comprise an electrical perimeter barrier as defined in 3.14. When processing classified information, there shall be a sign stating "DOOR NOT TO BE LEFT OPEN WHEN PROCESSING CLASSIFIED INFORMATION" visibly posted on the inside of the space adjacent to the door. This requirement does not apply to nonmetallic hull ships. Pri-2.

- * (U) 50.1.7 Separation. The computer system shall be installed a minimum of 3 feet from BLACK signal processors such as the following: Pri-1.
 - a. Radio transmitters and transceivers.

 - b. BLACK Modems and other modulating devices, such as AN/UCC-1(V) and CV-2460/SGC.

 - c. P/C radiotelephones with unfiltered transmit audio lines (see 5.1.11.5).

 - d. Transfer switchboards having a direct connection to radio transmitters or transceivers, such as transmitter transfer, receiver transfer, frequency selection transfer, data transfer and FSK/RFCS.

UNCLASSIFIED

MIL-STD-1680C(SH)
17 March 1993

APPENDIX F

INSPECTION CHECK-OFF SHEETS - Continued

APPENDIX J - MICRO/MINI COMPUTER SYSTEM

- (U) e. A BLACK or shared RED/BLACK teletype equipment with a send capability.

- f. Control units used with radio transmitters or transceivers, such as C-1004()/SG and C-9351/WSC-3(V).

- * (U) 50.2 Physical security. Storage shall be provided for classified discs and tapes used with the system. If classified information is resident in the computer when the compartment is unmanned, the compartment shall be designated a secure remote area and meet the physical security requirements for that type space. Pri-1

UNCLASSIFIED

MIL-STD-1680C(SH)
17 March 1993

APPENDIX G

SAMPLE INSPECTION REPORTS

(U) 10. SCOPE

(U) 10.1 Scope. This appendix provides sample inspection reports for a VTCCI, a partial VTCCI of a subsystem or equipment and a partial VTI of corrected discrepancies.

(U) 20. APPLICABLE DOCUMENTS

(U) 20.1 Not applicable.

(U) 30. DEFINITIONS

(U) 30.1 Not applicable.

(U) 40. GENERAL REQUIREMENTS

(U) 40.1 Purpose and coverage. A visual TEMPEST configuration control inspection is required for ships with an installed secure electrical information processing system (SEIPS). The inspection report and associated amendments shall reflect the existing configuration and all installation discrepancies.

(U) 50. DETAILED REQUIREMENTS

(U) 50.1 General. The report for a VTCCI or partial VTCCI shall be in the format provided in the sample inspection reports; however, the information required in enclosures to the inspection report will be different for each ship and is dependent on the systems installed, installation discrepancies, and the physical and electrical configuration of the installed systems. The data to be provided in enclosures to the inspection report shall be in sufficient detail to permit reviewing activities to determine the magnitude of a potential physical or electrical security hazard. Installation discrepancies shall be grouped by specific compartments and need not be on separate pages for individual compartments.

(U) 50.2 VTCCI report. The VTCCI report shall establish a baseline configuration for the secure electrical information processing system. The report will reflect inspection of the complete system and be in adequate detail to permit the reviewing activity to determine if existing installation discrepancies cause a potential security hazard.

UNCLASSIFIED

MIL-STD-1680C(SH)

17 March 1993

APPENDIX G

SAMPLE INSPECTION REPORTS

(U) 50.3 Partial VTCCI report. The report of a partial VTCCI is an amendment to the initial VTCCI and is required to ensure authorized changes to the system are reflected in the baseline configuration promulgated in the VTCCI report and to report the proper correction of previously reported discrepancies.

(U) 50.4 Configuration control drawings. Configuration control drawings shall indicate the location of secure processing centers within the ship and note any direct access between the secure processing center and a weather deck. The relative location of all equipment within the electrical perimeter barrier and the electrical configurations of power panels (where required), distribution panels, and signal patch and switch units in all locations shall be included in the plan and elevation drawings. (BLACK power transfer panel drawings are required only for ships with a RED high level signal distribution system).

UNCLASSIFIED

MIL-STD-1680C(SH)
17 March 1993

APPENDIX G

(U) SAMPLE OF VISUAL TEMPEST CONFIGURATION CONTROL INSPECTION REPORT

2241
Ser:
(DATE)

(SECURITY CLASSIFICATION) Unclassified upon removal of enclosure (1)

From: (FTA VISUAL TEMPEST INSPECTION ACTIVITY)
To: Commanding Officer, USS (SHIP INSPECTED)

Subj: VISUAL TEMPEST CONFIGURATION CONTROL INSPECTION REPORT (U)

Ref: (a) MIL-STD-1680C (SH), Installation Criteria for
Shipboard Secure Electrical Information Processing
Systems of 17 Mar 1993
(b) OPNAVINST C5510.93(E), Navy Implementation of
Control of Compromising Emanations of 22 Feb 1988

Encl: (1) Visual TEMPEST Inspection Report (C)
(2) Secure Electrical Information Processing System
Configuration Plan and Elevation Drawings
(3) Letter of Acceptance of Secure Electrical Information
Processing System Configuration Plan and Elevation
Drawings

* 1. (U) The Secure Electrical Information Processing System (SEIPS) aboard USS (SHIP INSPECTED) was inspected (WHEN) by (INSPECTOR'S NAME) FTA Card No. _____, FTA card expiration date _____. The inspection was conducted as required by reference (a). The SEIPS was (was not) in conformance with the installation criteria of reference (a). (Installation discrepancies are listed in enclosure (1).)

2. (U) (If the system is installed in accordance with reference (a).) Enclosures (1) and (2) provide a record of the SEIPS configuration at the time of the inspection. Reference (b) directs that measures be established and maintained for the control of alterations, modifications and changes to the SEIPS which are accomplished by forces afloat; therefore, modifications or changes to the SEIPS shall not be made without approval of the Type Commander or other appropriate authority.

CLASSIFIED BY NSA/CSSM 123-2
REVIEW ON: (DATE OF THIS LETTER PLUS 20 YEARS)

(SECURITY CLASSIFICATION)

UNCLASSIFIED

UNCLASSIFIED

MIL-STD-1680C(SH)
17 March 1993

APPENDIX G

(U) SAMPLE OF VISUAL TEMPEST CONFIGURATION CONTROL INSPECTION REPORT - Continued

(SECURITY CLASSIFICATION)

SUBJ: VISUAL TEMPEST CONFIGURATION CONTROL INSPECTION REPORT (U)

- * 2. (U) (If the system is not installed in conformance with reference (a).) This report provides a record of the installation discrepancies and the SEIPS configuration at the time of the inspection. Reference (b) directs that procedures be established for the correction of installation discrepancies and, further, directs establishment and maintenance of measures for the control of alterations, modifications and changes to SEIPS which are accomplished by forces afloat. The correction of installation discrepancies is required as specified in 50.1 Appendix F, reference (a), however, other modifications or changes to the SEIPS shall not be made without approval of the Type Commander.
3. (U) It is requested that the baseline configuration control drawings in enclosure (2) be verified, or dissimilarities noted, by completion and forwarding of enclosure (3) to (TYPE COMMANDER) with a copy to Commander, (Code 03K222), Naval Sea Systems Command, 2531 Jefferson Davis Hwy, Arlington, VA 22242-5160.
4. (U) This report and amendments to this report shall be retained in the ship's SEIPS documentation file as required in reference (b). This report shall be updated, or a new inspection shall be conducted and a new report submitted, once during each Engineering Operating Cycle.

Copy to: (w/o encl (3))
(Fleet Commanders in Chief)
COMSC (for MSC ships)
(Type Commander)
COMNAVSEASYSYSCOM (Code 03K222 and SHAPM or SLM)
DIRNAVCRIMINVSERV (Code 26T) (ships with SI spaces)
DIRECTOR ONI (Code 52) (ships with SI spaces which process SCI)
(Instrumented TEMPEST Survey Activity)
(Intermediate Unit Commander, if required)

(SECURITY CLASSIFICATION)

UNCLASSIFIED

MIL-STD-1680C(SH)
17 March 1993

APPENDIX G

(U) SAMPLE OF VISUAL TEMPEST INSPECTION REPORT

(SECURITY CLASSIFICATION)

(U) The entire secure electrical information processing system was inspected.

(U) The method of keying and signaling in Crypto Terminal Room, Message Processing Center, and War Room Comm Annex (and associated remote areas) is RED low level send and RED low level receive.

(U) The method of keying and signaling in SSES (and associated remote areas) is RED low level.

(U) The method of signaling in the RED CCTV system is RED low level (baseband).

* (U) List of spaces with secure processing equipment inspected by the visual TEMPEST inspector:

(U) Secure Processing Centers:

Message Processing Center (MPC), 03-24-0-C
Facilities Control (FACCON), 03-19-0-C
*Ship Signal Exploitation Space (SSES), 03-12-4-C
*Carrier Intelligence Center (CVIC), 03-101-0-C
*War Room Communications Annex, 03-110-1-C

(U) Secure Remote Areas:

*Radar Room Nr. TWO, 04-25-1-C
*Combat Information Center (CIC), Surface Ops,
04-100-5-C
Combat Information Center (CIC), ECM Room, 04-117-3-C
Combat Information Center (CIC), Detection and
Tracking, 04-110-5-C
*Combat Information Center (CIC), Display and Decision,
04-110-4-C
Meteorological Room (METRO), 05-109-5-Q

Enclosure (1)

(SECURITY CLASSIFICATION)

UNCLASSIFIED

UNCLASSIFIED

MIL-STD-1680C(SH)
17 March 1993

APPENDIX G

(U) SAMPLE OF VISUAL TEMPEST INSPECTION REPORT - Continued

(SECURITY CLASSIFICATION)

(U) *Primary Flight Control Station (PRIFLY), 07-112-1-C
Navigation Bridge, 06-110-1-C
Flag Bridge, 04-110-1-C

(U) Special Intelligence Spaces:

*Ship Signal Exploitation Space (SSES), 03-12-4-C
Ship Signal Exploitation Space Office, 03-10-4-C
Ship Signal Exploitation Space Monitor Room, 03-15-3-C
*Carrier Intelligence Center (CVIC), 03-101-0-C
Supplemental Plot (SUPPLOT), 02-26-4-C
CVIC Storage and Retrieval Room, 03-117-1-C
CVIC Electronic Data Processing Room, 03-119-1-C
*CVIC Mission Planning Area, 03-116-1-C

(U) Secure Video Control Spaces:

*CVIC Mission Planning Area, 03-116-1-C
*CIC Display and Decision, 04-110-4-C
*CIC Surface Ops, 04-100-5-C

(U) Secure Video Viewing Spaces:

Weapons Coordination Center, 01-102-5-C
*Flag Bridge, 04-110-1-C
Flag Plot, 02-112-1-C
CIC Air Operations, 04-117-1-C
CO Sea Cabin, 06-106-7-C
*Primary Flight Control Station (PRIFLY), 07-112-1-C
Ready Rooms #1, 2, 3 and 4

* Listed under more than one category.

(SECURITY CLASSIFICATION)

UNCLASSIFIED

UNCLASSIFIED

MIL-STD-1680C(SH)
17 March 1993

APPENDIX G

(U) SAMPLE OF VISUAL TEMPEST INSPECTION REPORT - Continued

(SECURITY CLASSIFICATION)

AREA: Message Processing Center (03-24-0-C)

	Discrepancy number				
	*				
		#			
			#		
1	1	X	5.1.4c	(C) AUTOVON dial telephone located within electrical perimeter barrier does not have telephone line filter.	
2	2	X	5.1.5	(C) F-1033/SG Filter Isolation Assembly bypassed on both send and receive d.c. landlines.	
3	1	X	5.1.10.2	(C) RED signal cable to AN/UGC-143 #1 is unshielded.	
4	1	X	5.1.10.2	(C) RED FRU cable from AN/UGC-143 #1 to SB-4074 #1 is unshielded.	
5	1	X	5.1.10.2	(C) RED primary a.c. power cable extended from AN/USQ-69 Nr.2 to AN/USQ-69 Nr.3, is non-shielded, rubber-covered power cable.	

The following comments are keyed to the applicable paragraphs of MIL-STD-1680C(SH):

LEGEND:

* - Correction priority assigned indicates item should be corrected as follows: 1 - immediately; 2 - prior to or during next scheduled availability; 3 - prior to or during next overhaul; CCA - on a case-by-case assessment by NAVSEA (Code 03K222) and TYCOM.

- Check either column to indicate whether the discrepancy can be corrected by ships force or requires industrial activity assistance.

(SECURITY CLASSIFICATION)

UNCLASSIFIED

UNCLASSIFIED

MIL-STD-1680C(SH)
17 March 1993

APPENDIX G

(U) SAMPLE OF VISUAL TEMPEST INSPECTION REPORT - Continued

(SECURITY CLASSIFICATION)

AREA: Message Processing Center (03-24-0-C)

Discrepancy number			
*	Correction priority		
#	Ships force		
	#Industrial activity		
6	1	X	5.2.12
7	1	X	5.2.14.5
8	1	X	5.2.14.12
9	1	X	5.1.9

The following comments are keyed to the applicable paragraphs of MIL-STD-1680C(SH):

(C) RED power panel 03-27-2 has two holes where cables have been removed.

(C) Dirt, grease and paint exist on surface contact area of bond strap at AN/UGC-143, Nr. 3.

(C) Slide foundations for AN/UGC-143 Nr. 2, Nr. 3 and Nr. 4 have bond straps, but are not connected to cabinet due to lost hardware.

(C) RED terminal box at frame 26 has no cover.

LEGEND:

* - Correction priority assigned indicates item should be corrected as follows: 1 - immediately; 2 - prior to or during next scheduled availability; 3 - prior to or during next overhaul; CCA - on a case-by-case assessment by NAVSEA (Code 03K222) and TYCOM.

Check either column to indicate whether the discrepancy can be corrected by ships force or requires industrial activity assistance.

(SECURITY CLASSIFICATION)

UNCLASSIFIED

MIL-STD-1680C(SH)
17 March 1993

APPENDIX G

(U) SAMPLE OF VISUAL TEMPEST INSPECTION REPORT - Continued

(SECURITY CLASSIFICATION)

AREA: Message Processing Center (03-24-0-C)

Discrepancy number			
	*		
Correction priority			
		#	
Ships force			
			#
Industrial activity			
10	2	X	5.3.1.11

The following comments are keyed to the applicable paragraphs of MIL-STD-1680C(SH):

(C) Interior of the secure processing center can be viewed through the bottom of the message passing window. Status board can be seen. Classified traffic cannot be seen. Unauthorized viewer would be in a squatting position in a passageway with moderate traffic during normal working hours, and practically no traffic during other hours.

LEGEND:

* Correction priority assigned indicates item should be corrected as follows:

1 - immediately; 2 - prior to or during next scheduled availability; 3 - prior to or during next overhaul; CCA - on a case-by-case assessment by NAVSEA (Code 03K222) and TYCOM.

- Check either column to indicate whether the discrepancy can be corrected by ships force or requires industrial activity assistance.

(SECURITY CLASSIFICATION)

UNCLASSIFIED

UNCLASSIFIED

MIL-STD-1680C(SH)
17 March 1993

APPENDIX G

(U) SAMPLE OF VISUAL TEMPEST INSPECTION REPORT - Continued

(SECURITY CLASSIFICATION)

AREA: SESS Monitor Room (03-15-3)

			Discrepancy number	
	*		Correction priority	
		#	Ships force	
			#Industrial activity	
11	1	X	A50.2.14	
12	2	X	A50.2.6	
13	2	X	A50.2.17	

The following comments are keyed to the applicable paragraphs of MIL-STD-1680C(SH):

(C) Call signal stations type IC/D has not been modified.

(C) Emergency exit scuttle sensor for alarm circuit can be switched to a disengage position at alarm panel.

(C) General announcing system 1MC speaker not equipped with a buffer amplifier.

LEGEND:

* - Correction priority assigned indicates item should be corrected as follows: 1 - immediately; 2 - prior to or during next scheduled availability; 3 - prior to or during next overhaul; CCA - on a case-by-case assessment by NAVSEA (Code 03K222) and TYCOM.

- Check either column to indicate whether the discrepancy can be corrected by ships force or requires industrial activity assistance.

(SECURITY CLASSIFICATION)

UNCLASSIFIED

UNCLASSIFIED

MIL-STD-1680C(SH)
17 March 1993

APPENDIX G

(U) SAMPLE OF VISUAL TEMPEST INSPECTION REPORT - Continued

(SECURITY CLASSIFICATION)

AREA: War Room Comm Annex (03-110-1-C)

	Discrepancy number			
		*	Correction priority	
		#	Ships force	
			#Industrial activity	
14	1	X	5.1.10.2	

The following comments are keyed to the applicable paragraphs of MIL-STD-1680C(SH):

(C) AN/UGC-143 #14 has an unshielded RED signal cable going to SB-4074/U #7.

LEGEND:

* - Correction priority assigned indicates item should be corrected as follows: 1 - immediately; 2 - prior to or during next scheduled availability; 3 - prior to or during next overhaul; CCA - on a case-by-case assessment by NAVSEA (Code 03K222) and TYCOM.

- Check either column to indicate whether the discrepancy can be corrected by ships force or requires industrial activity assistance.

(SECURITY CLASSIFICATION)

UNCLASSIFIED

UNCLASSIFIED

MIL-STD-1680C(SH)
17 March 1993

APPENDIX G

(U) SAMPLE OF VISUAL TEMPEST INSPECTION REPORT - Continued

(SECURITY CLASSIFICATION)

AREA: CIC Display and Decision (04-110-4-C)

	Discrepancy number
	* Correction priority
	# Ships force
	#Industrial activity
15	1
	X
	5.1.11.5

The following comments are keyed to the applicable paragraphs of MIL-STD-1680C(SH):

(C) P/C secure telephone set, TA-970/U, located 2 feet from AN/UGC-143 (link 14). No signal line filter in send line of TA-970/U.

LEGEND:

* - Correction priority assigned indicates item should be corrected as follows: 1 - immediately; 2 - prior to or during next scheduled availability; 3 - prior to or during next overhaul; CCA - on a case-by-case assessment by NAVSEA (Code 03K222) and TYCOM.

- Check either column to indicate whether the discrepancy can be corrected by ships force or requires industrial activity assistance.

(SECURITY CLASSIFICATION)

UNCLASSIFIED

UNCLASSIFIED

MIL-STD-1680C(SH)
17 March 1993

APPENDIX G

(U) SAMPLE OF INFORMATION PROCESSING SYSTEM CONFIGURATION PLAN AND ELEVATION DRAWINGS USS (SHIP INSPECTED)

1. These Secure Electrical Information Processing System Configuration Plan and Elevation Drawings are a record of the configuration of secure processing equipment in USS (SHIP INSPECTED) on (DATE).
2. Sketches of plan and elevation views are used to indicate the configuration within secure processing centers, and for large groups of secure processing equipment in a remote area. Otherwise, an inventory of RED equipment and space number is used to indicate the configuration in remote areas.

Enclosure (2)

UNCLASSIFIED

MIL-STD-1680C(SH)
17 March 1993

APPENDIX G

(U) SAMPLE OF INFORMATION PROCESSING SYSTEM CONFIGURATION PLAN
AND ELEVATION DRAWINGS USS (SHIP INSPECTED) - Continued

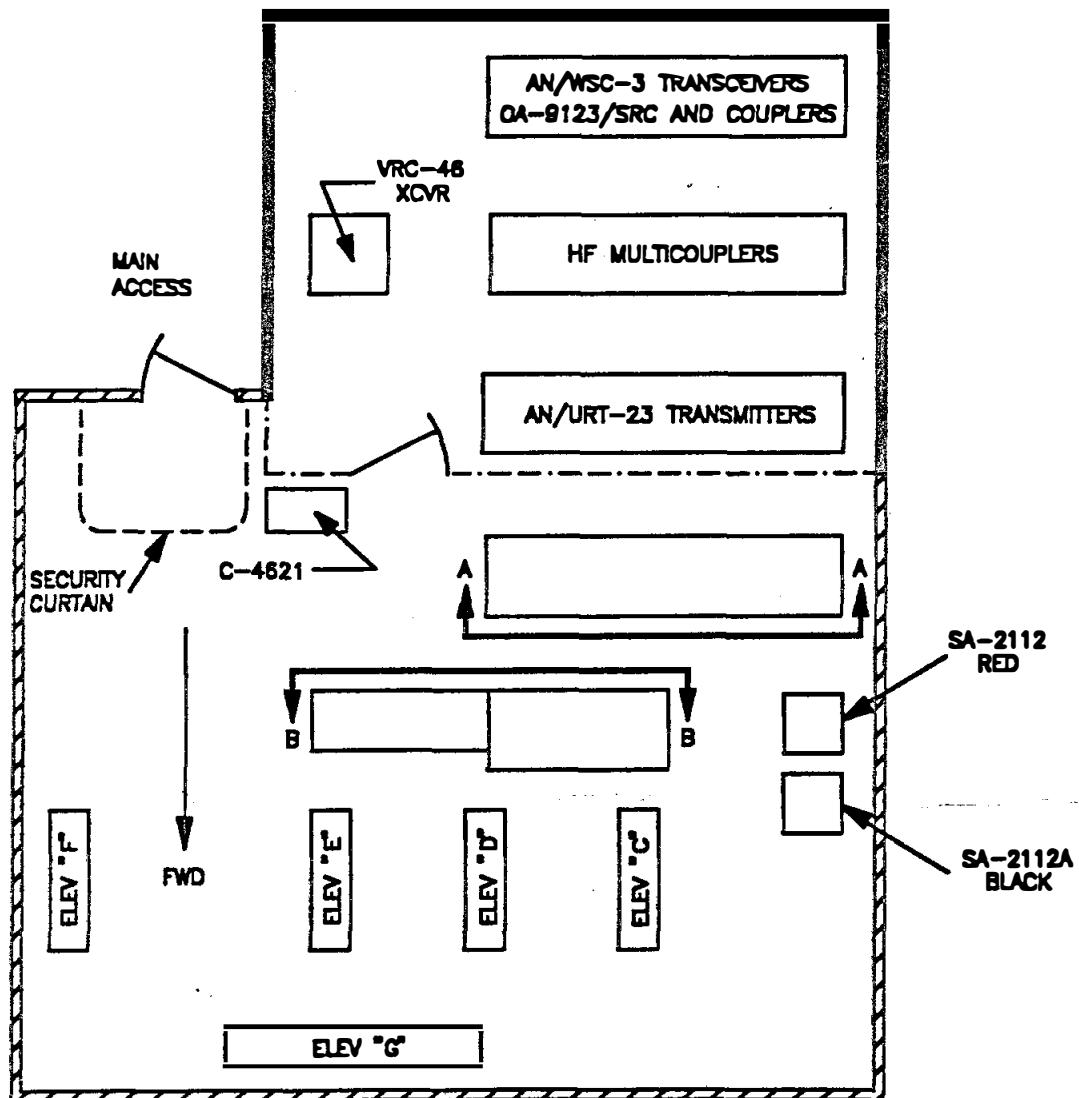

EPB/PPB

PPB

EPB

SAMPLE

UNCLASSIFIED

MIL-STD-1680C(SH)
17 March 1993

APPENDIX G

(U) SAMPLE OF INFORMATION PROCESSING SYSTEM CONFIGURATION PLAN
AND ELEVATION DRAWINGS USS (SHIP INSPECTED) - Continued

SAMPLE

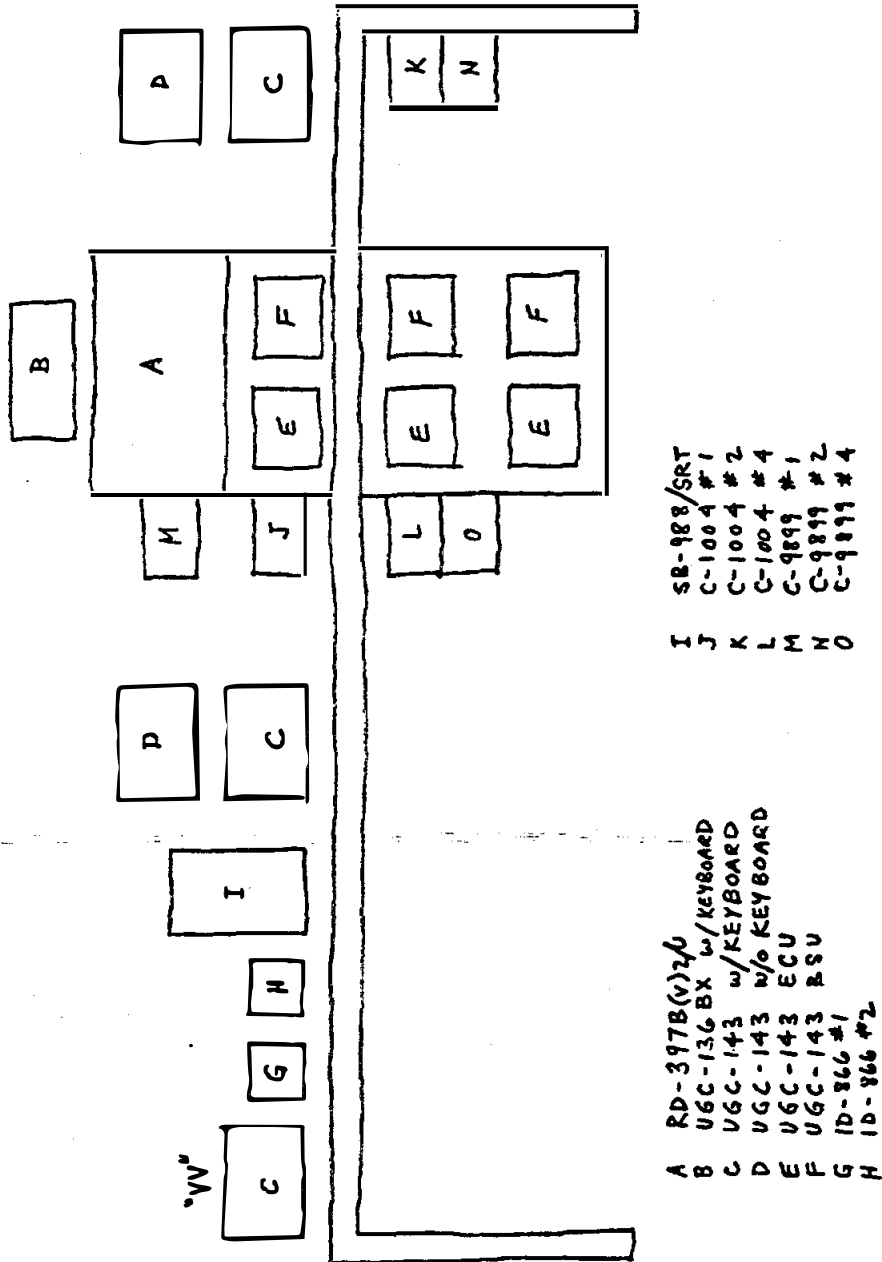

ELEVATION "D"

UNCLASSIFIED

MIL-STD-1680C(SH)
17 March 1993

APPENDIX G

(U) SAMPLE OF INFORMATION PROCESSING SYSTEM CONFIGURATION PLAN
AND ELEVATION DRAWINGS USS (SHIP INSPECTED) - Continued

SAMPLE

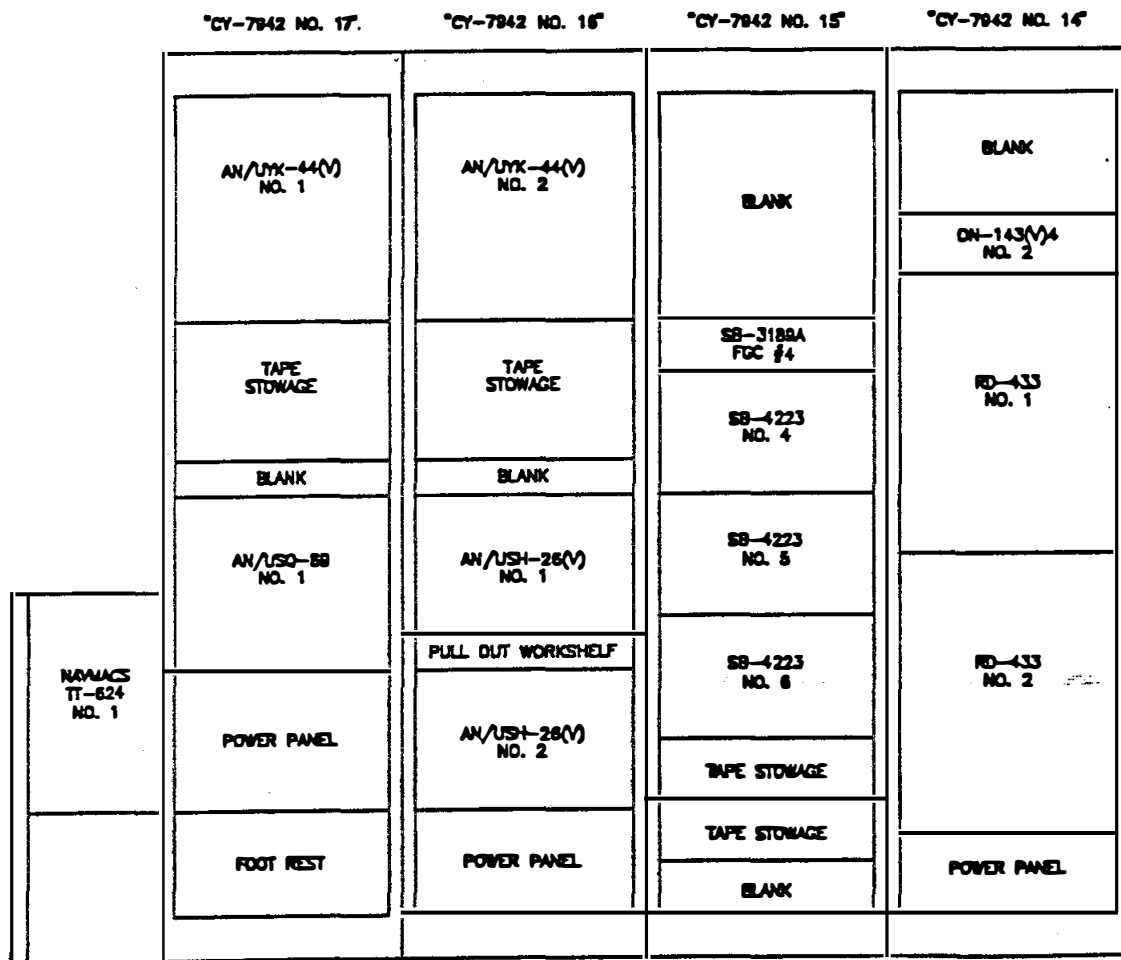

ELEVATION "G"

UNCLASSIFIED

MIL-STD-1680C(SH)
17 March 1993

APPENDIX G

(U) SAMPLE OF INFORMATION PROCESSING SYSTEM CONFIGURATION PLAN AND ELEVATION DRAWINGS USS (SHIP INSPECTED) - Continued

	1	2	3	4	5	6	7	8	9	10	11	12	13
MON	UD-44 NO. 1	UD-44 NO. 2	UD-44 NO. 3	UD-44 NO. 4		UD-44 NO. 1	UD-44 NO. 2	UD-44 NO. 3	UD-44 NO. 4	UD-44 NO. 1	UD-44 NO. 2	UD-44 NO. 3	UD-44 NO. 4
LINE													
EQUIP													
MISC	UD-44 NO. 3 PTE	UD-44 NO. 4 PTE	UD-44 NO. 1	UD-44 NO. 2	UD-44 NO. 3	UD-44 NO. 1	UD-44 NO. 2	UD-44 NO. 3	UD-44 NO. 4	UD-44 NO. 1	UD-44 NO. 2	UD-44 NO. 3	UD-44 NO. 4

	14	15	16	17	18	19	20	21	22	23	24	25	26
MON	UD-44 NO. 1 CH 3 NO. 2 CH 3 NO. 3 CH 3	UD-44 NO. 1 CH 1 NO. 2 CH 1 NO. 3 CH 1	UD-44 NO. 1 CH 2 NO. 2 CH 2 NO. 3 CH 2	UD-44 NO. 1 CH 4 NO. 2 CH 4 NO. 3 CH 4									
LINE													
EQUIP													
MISC													

SB-3189A/FGC #4

SAMPLE

UNCLASSIFIED

MIL-STD-1680C(SH)
17 March 1993

APPENDIX G

(U) SAMPLE OF INFORMATION PROCESSING SYSTEM CONFIGURATION PLAN
AND ELEVATION DRAWINGS USS (SHIP INSPECTED) - Continued

C-7594B/U #1

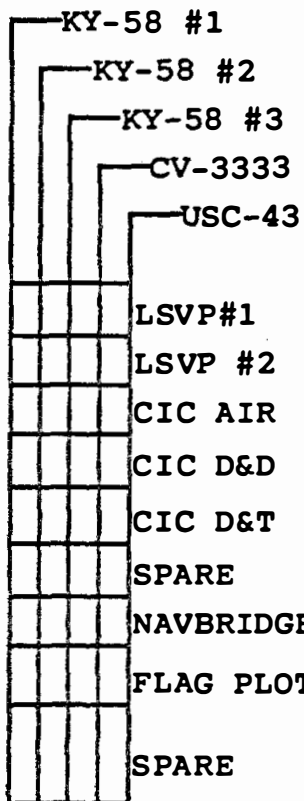

SECURE VOICE SWBD

C-7594B/U #2

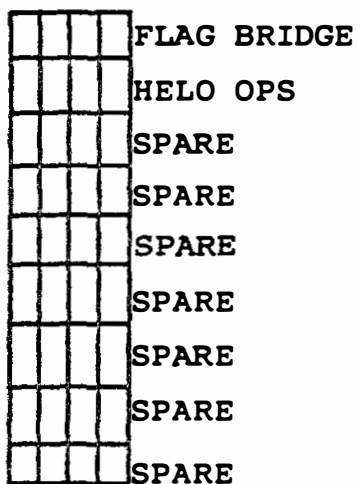

UNCLASSIFIED

MIL-STD-1680C(SH)
17 March 1993

APPENDIX G

(U) SAMPLE LETTER FOR VERIFICATION OF SEIPS CONFIGURATION DATA

2241
Ser
(DATE)

From: Commanding Officer, USS (SHIP INSPECTED)
To: Type Commander

Subj: ACCEPTANCE OF SECURE ELECTRICAL INFORMATION PROCESSING
SYSTEM CONFIGURATION PLAN AND ELEVATION DRAWINGS

Ref: (a) (FTA ACTIVITY) ltr 2241 Ser () of (DATE)

- * 1. Enclosure (2) of reference (a) has been reviewed for accuracy. The configuration control plan and elevation drawings are correct with the following exceptions:

Commanding Officer,
USS (SHIP INSPECTED)

Copy to:
(SAME DISTRIBUTION AS REF (A))
(FTA ACTIVITY)

Enclosure (3) (FTA INSPECTION ACTIVITY
LTR 2241 SER ____ OF DATE)

UNCLASSIFIED

MIL-STD-1680C(SH)
17 March 1993

APPENDIX G

(U) SAMPLE REPORT OF A PARTIAL VISUAL TEMPEST INSPECTION OF A SUBSYSTEM

2241
Ser
(DATE)

(SECURITY CLASSIFICATION) Unclassified upon removal of enclosure (1)

From: (FTA VISUAL TEMPEST INSPECTION ACTIVITY)
To: Commanding Officer, USS (SHIP INSPECTED)

Subj: REPORT OF USS (SHIP INSPECTED) PARTIAL VISUAL TEMPEST
INSPECTION OF A SUBSYSTEM

Ref: (a) Fonecon (DATE, (NAME/ACTIVITY) and (NAME/ACTIVITY)
(OR LETTER REQUESTING THE INSPECTION))
(b) MIL-STD-1680C(SH), Installation Criteria for
Shipboard Secure Electrical Information Processing
Systems of 17 Mar 1993
(c) (LAST KNOWN COMPLETE SYSTEM VTCCI REPORT)
(d) OPNAVINST C5510.93E, Navy Implementation of
Control of Compromising Emanations of 22 Feb 1988

Encl: (1) Visual TEMPEST Inspection Report (C)
(2) Secure Electrical Information Processing System
Configuration Plan and Elevation Drawings (U)
(3) Letter of Acceptance for Secure Electrical
Information Processing System Configuration Plan and
Elevation Drawings, (U)

- * 1.(U) As requested by reference (a) a visual TEMPEST configuration control inspection of the (NAME OF EQUIPMENT OR SUBSYSTEM INSPECTED) installation aboard USS (SHIP INSPECTED) was inspected (WHEN), by (INSPECTOR'S NAME) FTA Card No. _____, FTA card expiration date _____. The inspection was conducted as required by reference (b). The CLIPS was (was not) found to be in conformance with the installation criteria of reference (b). (Installation discrepancies are listed in enclosure (1)).
- * 2.(U) Enclosures (1) and (2) amend the baseline configuration documentation provided by reference (c) for the secure electrical information processing system. It is requested that the data in enclosure (2) be verified, or dissimilarities note, by completion and forwarding of enclosure (3).

CLASSIFIED BY NSA/CSSM 123-2
REVIEW ON: (DATE OF THIS LETTER PLUS 20 YEARS)

(SECURITY CLASSIFICATION)

UNCLASSIFIED

UNCLASSIFIED

MIL-STD-1680C(SH)
17 March 1993

APPENDIX G

(U) SAMPLE REPORT OF A PARTIAL VISUAL TEMPEST INSPECTION OF A SUBSYSTEM - Continued

3.(U) This report shall be retained with reference (c) in the ship's TEMPEST file in accordance with reference (d).

Copy to: (w/o encl (3))
(Fleet Commander in Chief)
COMSC (for MSC ships)
(Type Commander)
COMNAVSEASYSYSCOM (Code 03K222, SHAPM or SLM, as applicable)
COMNISCOM (Code 26T) (ships with SI spaces)
DIRECTOR ONI (Code 52) (ships with SI spaces which process SCI)
(Instrumented TEMPEST survey activity)
(Intermediate Unit Commander, if required)

UNCLASSIFIED

MIL-STD-1680C(SH)
17 March 1993

APPENDIX G

(U) SAMPLE REPORT OF A PARTIAL VISUAL TEMPEST
INSPECTION OF A SUBSYSTEM - Continued

(SECURITY CLASSIFICATION)

(U) The AN/USC-43(V)1 ANDVT upgrade installation within the communication center was inspected.

(U) The method of keying and signaling in the Communication Center (and associated remote areas) is RED high level send and RED high level receive.

Enclosure (1)

(SECURITY CLASSIFICATION)

UNCLASSIFIED

UNCLASSIFIED

MIL-STD-1680C(SH)
17 March 1993

APPENDIX G

(U) SAMPLE REPORT OF A PARTIAL VISUAL TEMPEST
INSPECTION OF A SUBSYSTEM - Continued

(SECURITY CLASSIFICATION)

AREA: Message Processing Center, 03-24-0-C

Discrepancy number			
* Correction priority			
# Ships force			
#Industrial activity			
1	1	X	5.2.14.13
2	2	X	5.3.1.11

The following comments are
keyed to the applicable
paragraphs of
MIL-STD-1680C(SH):

(C) Neither Basic Terminal Unit (BTU) has the correct Class C bond strap to ground; each unit has AWG 14 wire from the ground stud to the foundation and is not acceptable as a bond strap.

(C) Access to latch on normal access door is possible via the message passing window. Window needs to have locks on the metal door replaced.

LEGEND:

* Correction priority assigned indicates item should be corrected as follows:

1 - immediately; 2 - prior to or during next scheduled availability; 3 - prior to or during next overhaul; CCA - on a case-by-case assessment by NAVSEA (Code 03K222) and TYCOM.

Check either column to indicate whether the discrepancy can be corrected by ships force or requires industrial activity assistance.

(SECURITY CLASSIFICATION)

UNCLASSIFIED

UNCLASSIFIED

MIL-STD-1680C(SH)
17 March 1993

APPENDIX G

(U) SAMPLE PLAN AND ELEVATION VIEW DIAGRAMS OF A PARTIAL VISUAL TEMPEST INSPECTION OF A SUBSYSTEM

SAMPLE

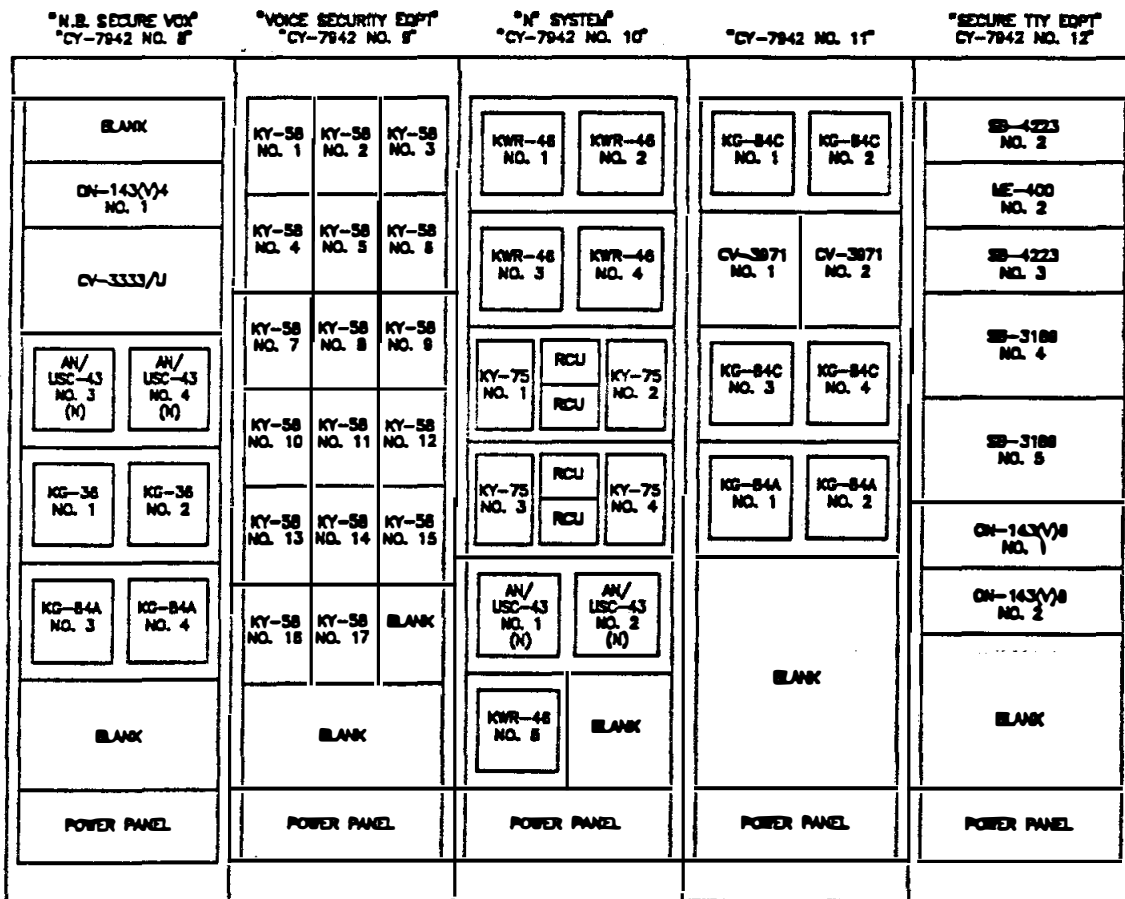

(N) = NEW EQUIPMENT

ELEVATION "E"

Enclosure (2)

UNCLASSIFIED

MIL-STD-1680C(SH)
17 March 1993

APPENDIX G

(U) SAMPLE LETTER FOR VERIFICATION OF SEIPS CONFIGURATION DATA

2241
Ser
(DATE)

From: Commanding Officer, USS (SHIP INSPECTED)
To: (Type Commander)

Subj: ACCEPTANCE OF SECURE ELECTRICAL INFORMATION PROCESSING
SYSTEM CONFIGURATION CONTROL PLAN AND ELEVATION DRAWINGS

Ref: (a) (FTA ACTIVITY) ltr 2241 Ser () of (DATE)

- * 1. Enclosure (2) of reference (a) has been reviewed for accuracy. The configuration control plan and elevation drawings are correct with the following exceptions:

Commanding Officer,
USS (SHIP INSPECTED)

Copy to:
(SAME DISTRIBUTION AS REF (A))
(FTA ACTIVITY)

Enclosure (3) (FTA INSPECTION ACTIVITY
LTR 2241 SER _____ OF (DATE))

UNCLASSIFIED

MIL-STD-1680C(SH)
17 March 1993

APPENDIX G

(U) SAMPLE REPORT OF A PARTIAL VISUAL TEMPEST INSPECTION OF PREVIOUSLY REPORTED DISCREPANCIES

2241
Ser
(DATE)

From: (FTA VISUAL TEMPEST INSPECTION ACTIVITY)
To: Commanding Officer, USS (SHIP INSPECTED)

Subj: REPORT OF USS (SHIP INSPECTED) VISUAL TEMPEST INSPECTION
OF PREVIOUSLY REPORTED DISCREPANCIES

Ref: (a) (REPORT IDENTIFYING THE DISCREPANCIES)
(b) MIL-STD-1680C (SH), Installation Criteria for
Shipboard Secure Electrical Information Processing
Systems of 17 March 1993

- * 1. An inspection of discrepancies reported in reference (a) was conducted by (INSPECTOR'S NAME, FTA CARD NUMBER AND EXPIRATION DATE) on (DATE). The discrepancies have (have not) been corrected and are (are not) in accordance with the criteria. (Percentage) percent of the discrepancies reported in reference (a) as correctable by ships force have been corrected.
- * 2. The following discrepancies reported in reference (a) are within the capability of ships force to correct and have not been corrected. This represents (percentage) percent of the discrepancies reported as correctable by ships force. (List by discrepancy number).
- * 2. or 3. (As applicable) (Quantity) discrepancies reported in reference (a) are not correctable by ships force and (will be/have been) entered in the ships CSMP for correction during the next availability.
- * 2., 3. or 4. (As applicable) This report is an amendment to reference (a) and shall be retained in the ships TEMPEST file.

/s/

Copy to:
(SAME DISTRIBUTION AS REF (a))

(Note: If the MIL-STD-1680C paragraph numbers or a narrative of the discrepancy is included, classify according to content (see 6.5.3))

UNCLASSIFIED

MIL-STD-1680C(SH)
17 March 1993

APPENDIX H

BOATS AND CRAFT

- * (U) 10. SCOPE
- * (U) 10.1 Scope. This appendix defines the complete installation criteria providing electrical and physical security for CLIPS in boats and craft of the U.S. Navy, Marine Corps and Coast Guard.
- * (U) 20. APPLICABLE DOCUMENTS
- * (U) 20.1 NAVSEA 0902-LP-041-2010 Standard Specifications for U.S. Navy Craft
- * (U) 30. DEFINITIONS
- * (U) 30.1 Boats and Craft. A term collectively applying to units that do not have a self-sustaining capability in excess of 96 hours; the units rely on a parent ship or base for primary support.
- * (U) 40. GENERAL REQUIREMENTS
- * (U) 40.1 TEMPEST-related installation requirements. The installation standards herein shall be implemented as specified to reduce or eliminate the possibility of inadvertent egression of Compromising Emanations (CE) to the extent required to conform with applicable criteria established by OPNAVINST C5510.93.
- * (U) 40.1.1 Electrical signal distribution system. The criteria herein is applicable to CLIPS that are limited to secure voice and IFF.
- * (U) 40.1.2 Data and teletype. A CLIPS employing RED data or teletype signaling shall be submitted to NAVSEA 03K222 for development of specialized criteria.
- * (U) 40.1.3 SPAWAR TEMPEST-approved equipment and systems. Where a detailed requirement specifies the use of a SPAWAR TEMPEST-approved equipment or system, such system shall be listed in paragraph 50.1, 50.2 or 50.3 in Appendix D of this standard.
- * (U) 40.1.4 TEMPEST-related and supportive details. The detailed requirements for TEMPEST-related installation criteria and their supportive details are specified in 50.1 through 50.2.3.7 of this appendix. The shipboard TEMPEST-related

UNCLASSIFIED

MIL-STD-1680C(SH)
17 March 1993

APPENDIX H

BOATS AND CRAFT

(U) criteria of paragraphs 5.1 through 5.2.15.1 of this standard shall not be applied to Boats and Craft unless specifically referred to in this appendix.

- * (U) 40.2 Physical security installation requirements. The general requirements for physical and operational security criteria is to:
 - a. Physically protect classified information and materials.
 - b. Assist in the operational control of equipment.
 - c. Prevent inadvertent compromises.
 - d. Maintain the cryptographic equipment security level.
- * (U) 40.3 Applicability. This appendix is applicable to an installation in a boat or craft requiring fixed cabling, racks and foundations for the RED processing equipment, or communication equipment, or both. It is not applicable where the cryptographic and communication equipment are both carried onto the craft or boat as hand-carried or manpack configurations, and do not use the cabling and support facilities of the boat or craft. Unless otherwise specified in the detailed boat/craft installation requirements, specifications or contract, the criteria of this appendix shall be applied to boats and craft as specified herein.
- * (U) 50. DETAILED REQUIREMENTS
- * (U) 50.1 General. The detailed requirements of TEMPEST-related installation criteria (see 50.1.1), support of TEMPEST-related installation criteria (see 50.2.1), and physical security installation criteria (see 50.3.1) are separately grouped. Unless otherwise specified, each detailed requirement is applicable to boats and craft.
- * (U) 50.1.1 RED and BLACK electrical signal distribution system interfacing. RED and BLACK electrical signal distribution systems shall be electrically interfaced only by:
 - a. SPAWAR TEMPEST-approved isolation devices.
 - b. Cryptographic equipment.

UNCLASSIFIED

MIL-STD-1680C(SH)
17 March 1993

APPENDIX H

BOATS AND CRAFT

- (U) c. SPAWAR TEMPEST-approved switches used for secure/non-secure purposes.
- * (U) 50.1.2 Combined radio and secure systems. Combined radio and secure systems shall be installed in boats and craft in accordance with the following:
 - a. Where a radio transceiver and secure voice processing equipment share common circuitry, such as power supplies, by system design, such system shall be SPAWAR TEMPEST-approved prior to installation.
 - b. Where a unit of a radio transmitter performs the function of switching between plain and cipher voice, the total system of radio and RED processing equipment shall be TEMPEST approved prior to installation.
- * (U) 50.1.3 Primary power. SPAWAR TEMPEST-approved equipment shall be connected to BLACK power.
- * (U) 50.1.3.1 RED Power. RED power shall be derived from power filters that provide 100 dB of attenuation within the stopband of 14 kHz to 1 GHz. They shall be installed as close as practical to the equipment requiring RED power.
- * (U) 50.1.4 Cable. Cabling in the secure processing system shall comply with the following:
 - a. RED cable shall be shielded.
 - b. RED cables containing conductors connected to a RED low level electrical signal distribution system may also contain conductors connected to the BLACK electrical signal distribution system provided the RED conductors are individually shielded, as balanced twisted pairs or overall shielded from the BLACK conductors.
 - c. RED signal and control lines shall be composed of twisted pairs of conductors, and shall not use the shield/armor of the cable or the boat/craft hull for the electrical return path. Coaxial cables are excluded from this requirement.

UNCLASSIFIED

MIL-STD-1680C(SH)
17 March 1993

APPENDIX H

BOATS AND CRAFT

- (U) d. Cables and conductors serving secure voice processing equipment shall be isolated in the following manner:
- (1) Transmit and receive audio lines shall be balanced twisted pairs with each pair non-ferrous shielded, and the shields insulated from each other. An exception to this may be where the transmit pair and associated transmit control lines are contained in one cable with an overall non-ferrous shield, and the associated receive audio is contained in a separate twisted shielded pair cable.
 - (2) When a multi-circuit cable is used, as a minimum, each transmit and receive audio twisted pair shall be non-ferrous shielded with all shields insulated and an overall insulating sheath.
 - (3) In a cable containing only one secure voice send/receive circuit and not exceeding 25 feet in length, the cable may have an overall non-ferrous shield, and an overall insulating sheath.
- e. Junction boxes may be used as an intermediate connection point for cables containing both RED and BLACK circuits. Cables and conductors within a shared junction box shall conform with the following:
- (1) The lay of the twisted pair shall be retained within the box up to the point of termination on the terminal strip.
 - (2) The shield over the twisted pair shall be retained within the box up to the point of termination on the terminal strip.
 - (3) The shield shall be bonded to ground at the terminal strip.
 - (4) Conductors within the box shall be as short as possible, yet long enough to reach any terminal connection in the box.

* (U) 50.1.5 Secure voice signal lines. Secure voice signal lines shall operate as a 600-ohm balanced system.

UNCLASSIFIED

MIL-STD-1680C(SH)
17 March 1993

APPENDIX H

BOATS AND CRAFT

- * (U) 50.1.6 Bonding. Cryptographic equipment, RED electrical processing equipment, RED cable shields and armor, and power filters shall be bonded to ground. Spare conductors in RED cables shall be connected to ground at both ends.
- * (U) 50.2 Support of TEMPEST-related installation criteria. The requirements listed herein support the TEMPEST-related installation criteria of 50.1 with standardized methods and procedures for installation.
- * (U) 50.2.1 Cryptographic equipment modification. Modification of cryptographic equipment shall not be made without proper authority. Authorized modifications to a cryptographic equipment are promulgated as changes to the KAM maintenance manual for that cryptographic equipment.
- * (U) 50.2.2 Cryptographic equipment cables. The cables supplied with cryptographic equipment are often of specific length, wire gauge or shielding characteristics, and are part of the total system design. The fully assembled cables shall not be modified or reduced in length, unless promulgated as part of an authorized change.
- * (U) 50.2.3 Bonding methods. The various parts, units and assemblies of a RED electrical processing system shall be bonded to ground as specified herein. General bonding requirements for electromagnetic compatibility (EMC) and safety shall comply with MIL-STD-1310 to the extent such requirements do not conflict with the requirements herein. One bonding method per equipment may suffice as long as it meets the minimum bonding and grounding requirements of personnel safety, EMC and TEMPEST. In non-metallic hull boats and craft, the third wire or safety ground shall be an acceptable substitute for any bond strap specified herein.
- * (U) 50.2.3.1 Bonding via mounting hardware. Equipment, cabinets, consoles and junction boxes containing RED circuits shall be bonded to ground utilizing the available mounting holes provided, unless otherwise directed. Bolts, nuts and washers shall be CRES Series 300 using a size corresponding to the existing mounting holes; if holes must be drilled, minimum nominal diameter shall be for 0.25-inch hardware. The bonding contact area shall be cleaned to bare metal. Class 3 chemical coatings, i.e., anodizing, applied in accordance with MIL-C-5541 is a conductive coating and shall not be removed. Where feasible, a bond may be accomplished via a weld, braze or bond

UNCLASSIFIED

MIL-STD-1680C(SH)
17 March 1993

APPENDIX H

BOATS AND CRAFT

(U) strap in addition to, or instead of, the mounting hardware. The above is predicated on the fact that such units are installed in, or on metallic enclosures or foundations. The enclosure or foundation shall be a metallic extension of the hull or have an electrical ground connection to the electrical ground bus.

- * (U) 50.2.3.2 Solid bond straps. Solid bond strap material shall be copper, at least 0.020-inches thick, and at least 3/4-inch wide. The length of the bond strap shall not be greater than 5 times the width and shall be as short as practical. Punch or cut out mounting holes for 5/16-inch hardware. Zinc plating or other protective coating shall be used on bond straps to prolong the effective life of the strap and reduce galvanic action between dissimilar metals. Bolts, nuts and washers shall be CRES Series 300. Bond straps shall be installed in locations that permit rapid inspection and replacement. Bonds shall in no way interfere with internal parts of the equipment or the movement of resilient mounts. Ground studs built into equipment enclosures shall be utilized in preference to drilling a new hole, providing(ed) the ground stud location on the enclosure will not increase the length of the bond strap beyond normal tolerances. The bonding contact area shall be cleaned to bare metal. Cleaned areas and threaded hardware shall be coated with an anti-seize compound, conforming to MIL-T-22361 prior to the installation of the bond strap to prolong the effective life of the bond. A class 3 chemical coating, i.e., anodizing, applied in accordance with MIL-C-5541 is a conductive coating and shall not be removed.
- * (U) 50.2.3.3 Cryptographic equipment. Cryptographic equipment and cryptographic ancillary units (for example, TSEC nomenclature equipment) shall be bonded to ground utilizing the available mounting holes and hardware provided, except as indicated herein.
 - a. TSEC/KY-58. (See 5.2.14.13.1)
 - b. TSEC/KYV-5. (See 5.2.14.13.p)
 - c. TSEC/KI-1A (See 5.2.14.13.c)
- * (U) 50.2.3.4 Power filters. The case of a power filter, if not bonded to ground with the mounting hardware, shall be bonded to ground with a solid class C bond strap.

UNCLASSIFIED

MIL-STD-1680C(SH)
17 March 1993

APPENDIX H

BOATS AND CRAFT

- * (U) 50.2.3.5 Resilient mounted equipment. Resilient mounted equipment shall be bonded to ground with a class C bond strap. Flexible bond straps may be used on equipment having resilient mounts which allow multidirectional excursions that may damage solid class C bond straps.
- * (U) 50.2.3.6 Bonding of shields and armor on RED cables. RED cables shall have the shields (and armor, if applicable) of the cable bonded to ground at both ends. Cable shields for secure voice circuit terminations on barrier terminal strips (as in 50.1.4.f) shall be bonded to ground within the enclosure at the terminal strip. Other cable shields shall be bonded to ground within an enclosure at a terminal strip or at the point of entry to the enclosure. Armor shall be bonded to ground at the entry to the enclosure.
- * (U) 50.2.3.7 Unused and spare conductors. Unused or spare conductors and shields of RED cables shall be bonded to ground at both ends. Such conductors shall have sufficient length to be connected to any of the terminations.
- * (U) 50.3 Physical security installation criteria. The requirements listed herein comprise the physical security installation criteria with standardized methods and procedures for installation.
- * (U) 50.3.1 Security spaces. Secure processing centers, secure remote areas, remote areas and exposed remote stations are not elements of the secure processing system in boats and craft. Cryptographic equipment and RED processing equipment shall be installed in enclosed stations or unprotected stations as defined herein.
- * (U) 50.3.2 Location of cryptographic and RED processing equipment. Cryptographic and RED processing equipment shall be installed in accordance with the following order of preference, dependent upon size and configuration of the boat or craft:
 - a. Within an enclosed station that has a deck, overhead and complete bulkheads, with access/exits constructed to preclude access to, or viewing of, the interior. There shall be only one access

UNCLASSIFIED

MIL-STD-1680C(SH)
17 March 1993

APPENDIX H

BOATS AND CRAFT

- (U) door. This door shall be equipped with locking devices, and as a minimum shall be a lock hasp with a medium security padlock. Emergency exits shall be operable only from inside the space. An electronic equipment room, a radio room or a secure equipment room may be an enclosed station.
- b. Within an enclosed station not able to meet the perimeter requirements of a. above, such as a pilot house. A secure storage container shall be provided for COMSEC paper material, equipment and other classified documents.
- c. At an unprotected station that will obviously have someone in attendance, such as the coxswain or pilot, while cryptographic equipment is installed. The installation shall be electrically and physically configured so that the cryptographic equipment can be easily removed from its normal foundation or housing to a more secure storage. A removable weighted container suitable for the storage of classified documents with minimum dimensions of 11.5" X 9" X 3" shall be provided. The container shall be fastened to the structure of the craft by lanyard or other equally secure method. An open conning station or coxswains station may be an unprotected station.

* (U) 50.3.3 RED and BLACK system sharing. RED and BLACK electrical distribution systems may share the same processing equipment when specified in NAVSEA drawings or documents to meet operational requirements. A transfer, patching or switching system used to connect a position alternately to a RED or BLACK system shall:

- a. Have clearly identified controls with a visual status indication at the operating position or equipment terminal.
- b. Be secure against accidental or unauthorized connection of circuit, channel, or position to the secure or non-secure positions.
- c. Be impossible to by-pass unintentionally.

UNCLASSIFIED

MIL-STD-1680C(SH)
17 March 1993

APPENDIX H

BOATS AND CRAFT

- (U) d. For semi-automatic or automatic systems where manual manipulation is not employed, provide fail-safe operation by circuit lock-up or positive diversion to a secure system in the event of equipment malfunction
 - e. Be considered a part of the secure system to which it will be connected and be afforded the same physical security.
- * (U) 50.3.4 Speaker disconnect switch. Secure voice monitor speakers shall be capable of being locally disconnected from signal lines. The disconnect feature may be located in the local telephone set (for example, TA-970/U) or on the speaker amplifier.
- * (U) 50.4 Temporary installations. Temporary installations shall comply with all the applicable requirements of this appendix.

UNCLASSIFIED

MIL-STD-1680C(SH)

17 March 1993

APPENDIX I

ILLUSTRATIONS

(U) 10. SCOPE

(U) 10.1 Scope. This appendix contains unclassified illustrations covering installation criteria for shipboard secure electrical information processing systems.

* (U) 20. REFERENCED DOCUMENTS

* (U) 20.1 This section is not applicable to this appendix.

* (U) 30. DEFINITIONS

* (U) 30.1 This section is not applicable to this appendix.

* (U) 40. GENERAL REQUIREMENTS

* (U) 40.1 The illustrations contained in this appendix illustrate installation criteria cited in sections 5.1, 5.2, 5.3, Appendix A and Appendix B.

* (U) 50. DETAILED REQUIREMENTS

* (U) 50.1 TEMPEST installation criteria illustrations. The following illustrations may be used to assist in the planning, design and inspection of secure electrical information processing systems.

UNCLASSIFIED

MIL-STD-1680C(SH)
17 March 1993

APPENDIX I

ILLUSTRATIONS

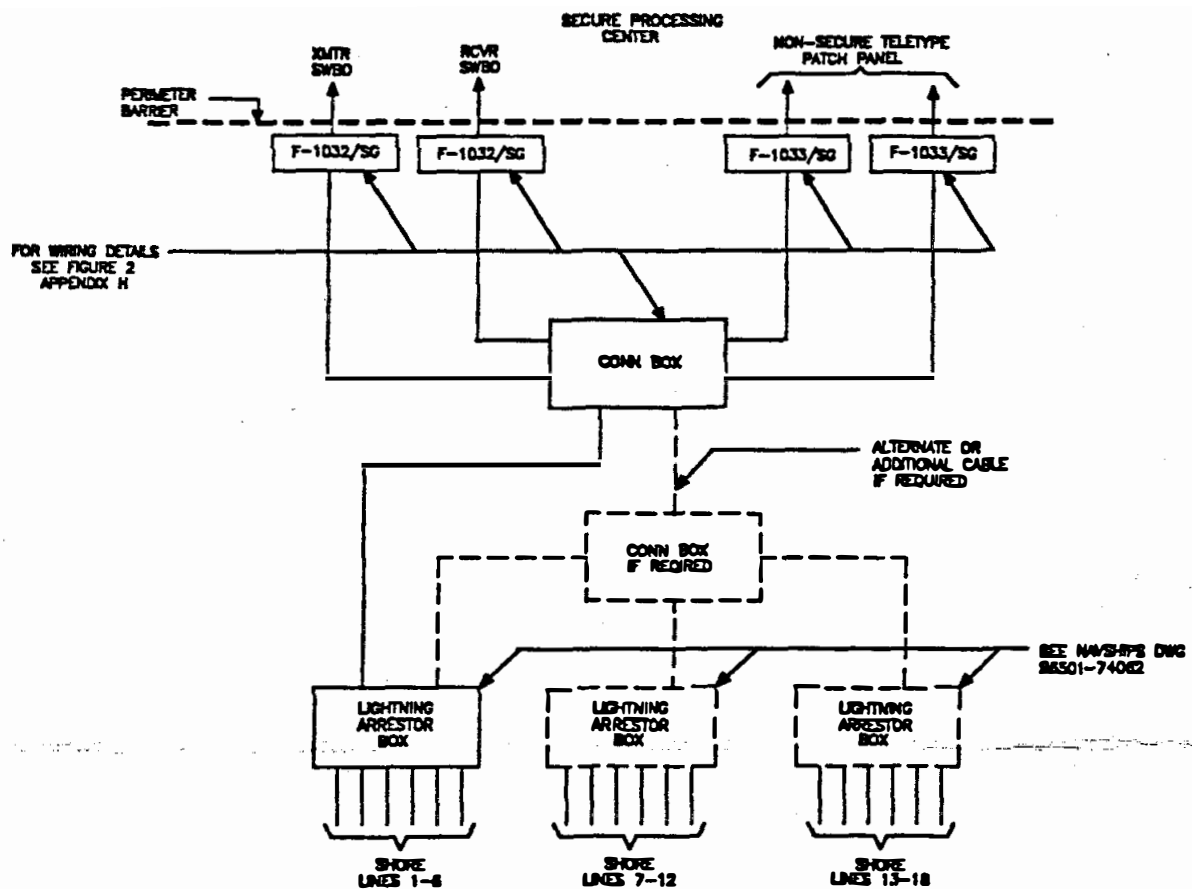

(U) FIGURE 1. Landline installation block diagram.

UNCLASSIFIED

MIL-STD-1680C(SH)
17 March 1993

APPENDIX I

ILLUSTRATIONS

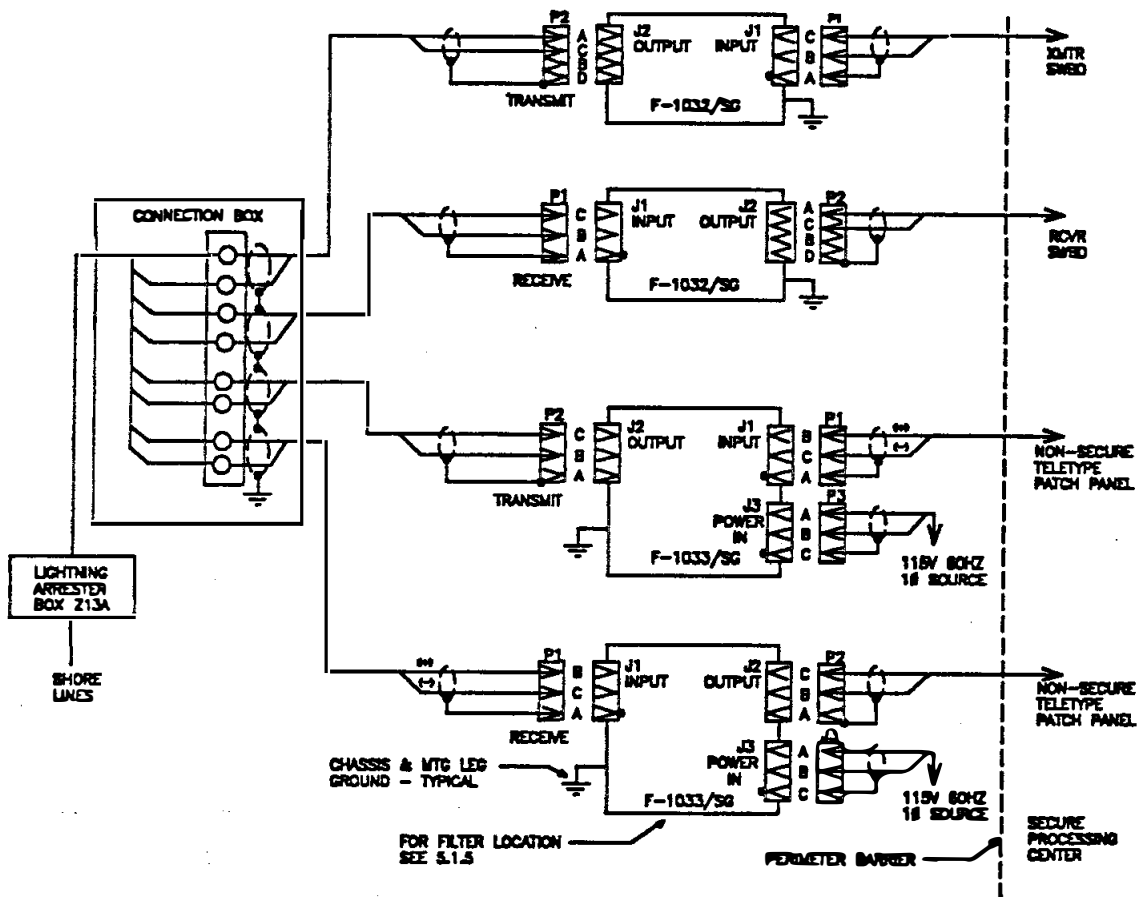

(U) FIGURE 2. Landline installation wiring diagram.

UNCLASSIFIED

MIL-STD-1680C(SH)
17 March 1993

APPENDIX I

ILLUSTRATIONS

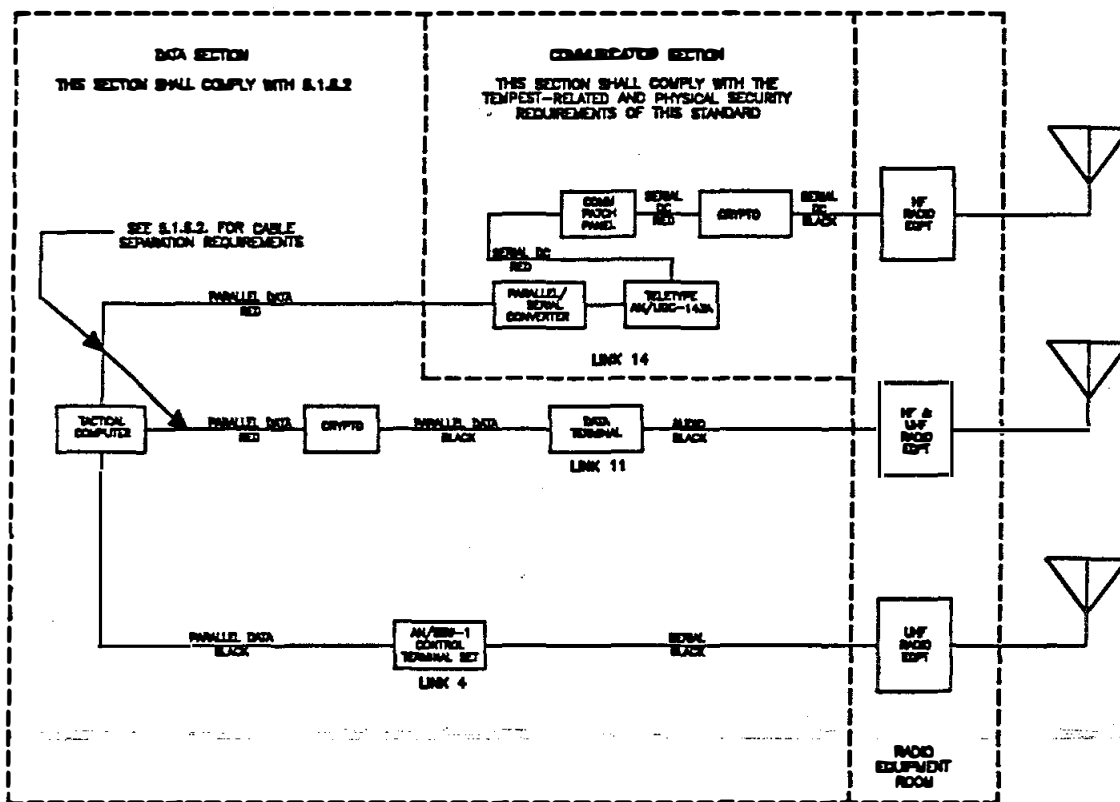

(U) FIGURE 3. NTDS block diagram.

UNCLASSIFIED

MIL-STD-1680C(SH)
17 March 1993

APPENDIX I

ILLUSTRATIONS

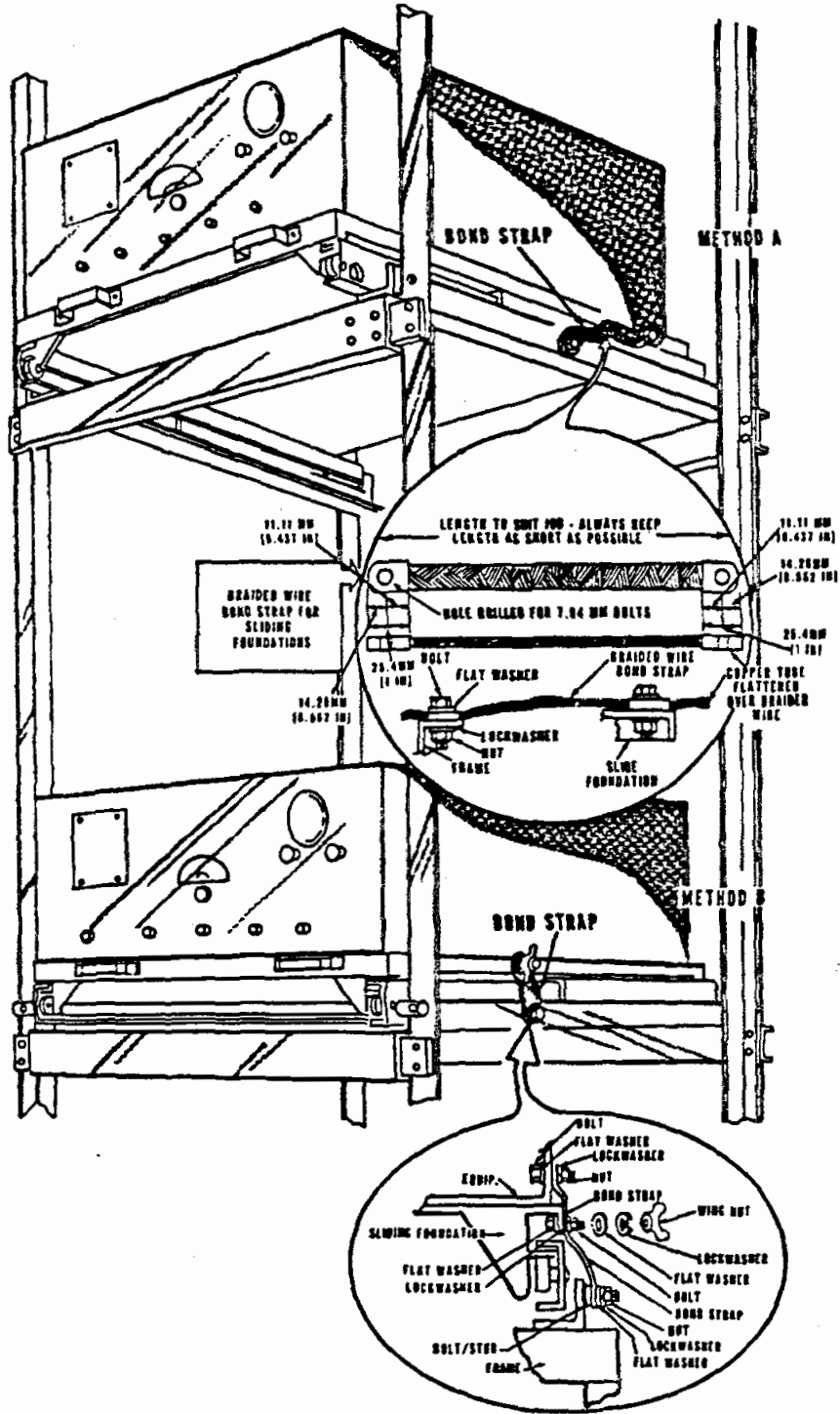

(U) FIGURE 4. Bonding of slide foundation.

UNCLASSIFIED

MIL-STD-1680C(SH)
17 March 1993

APPENDIX I ILLUSTRATIONS

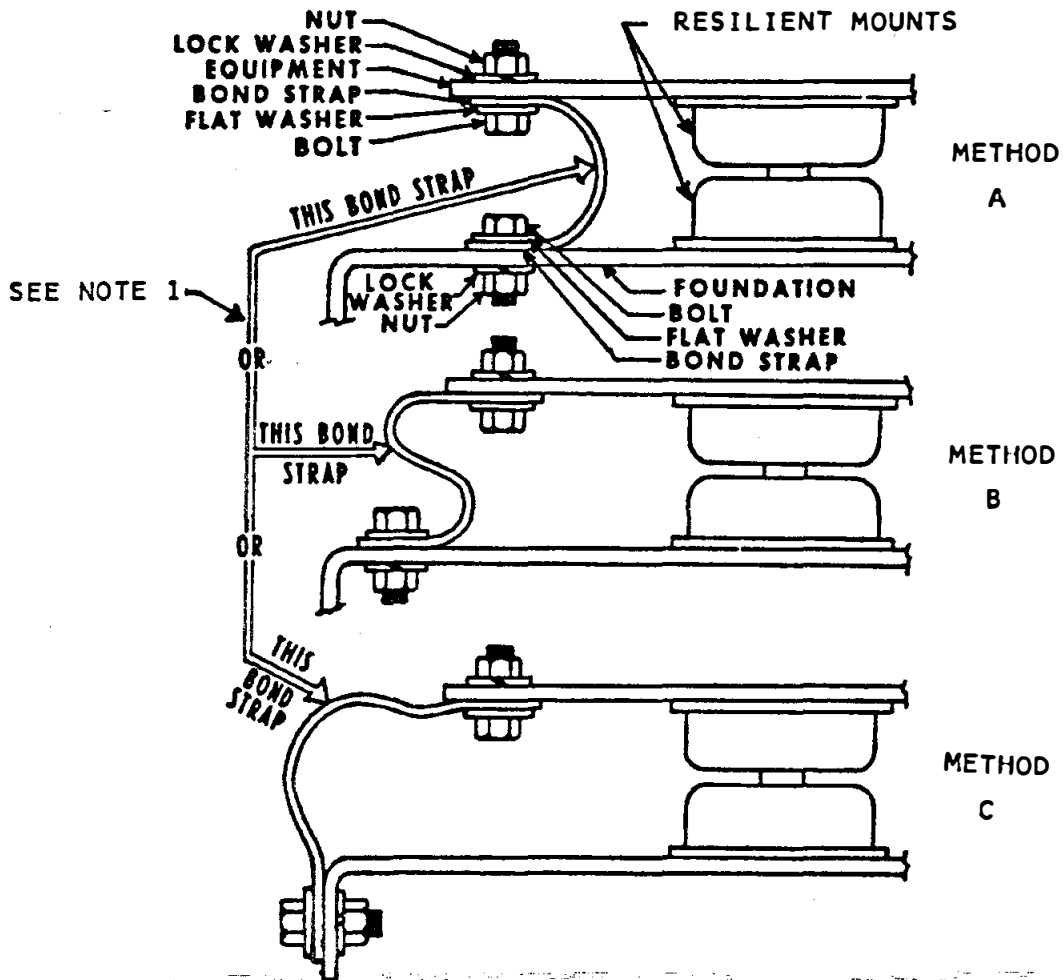

NOTE:

1. ORDER OF PREFERENCE:
METHOD A
METHOD B
METHOD C

(U) FIGURE 5. Bonding of resilient mounted equipment.

UNCLASSIFIED

MIL-STD-1680C(SH)
17 March 1993

APPENDIX I ILLUSTRATIONS

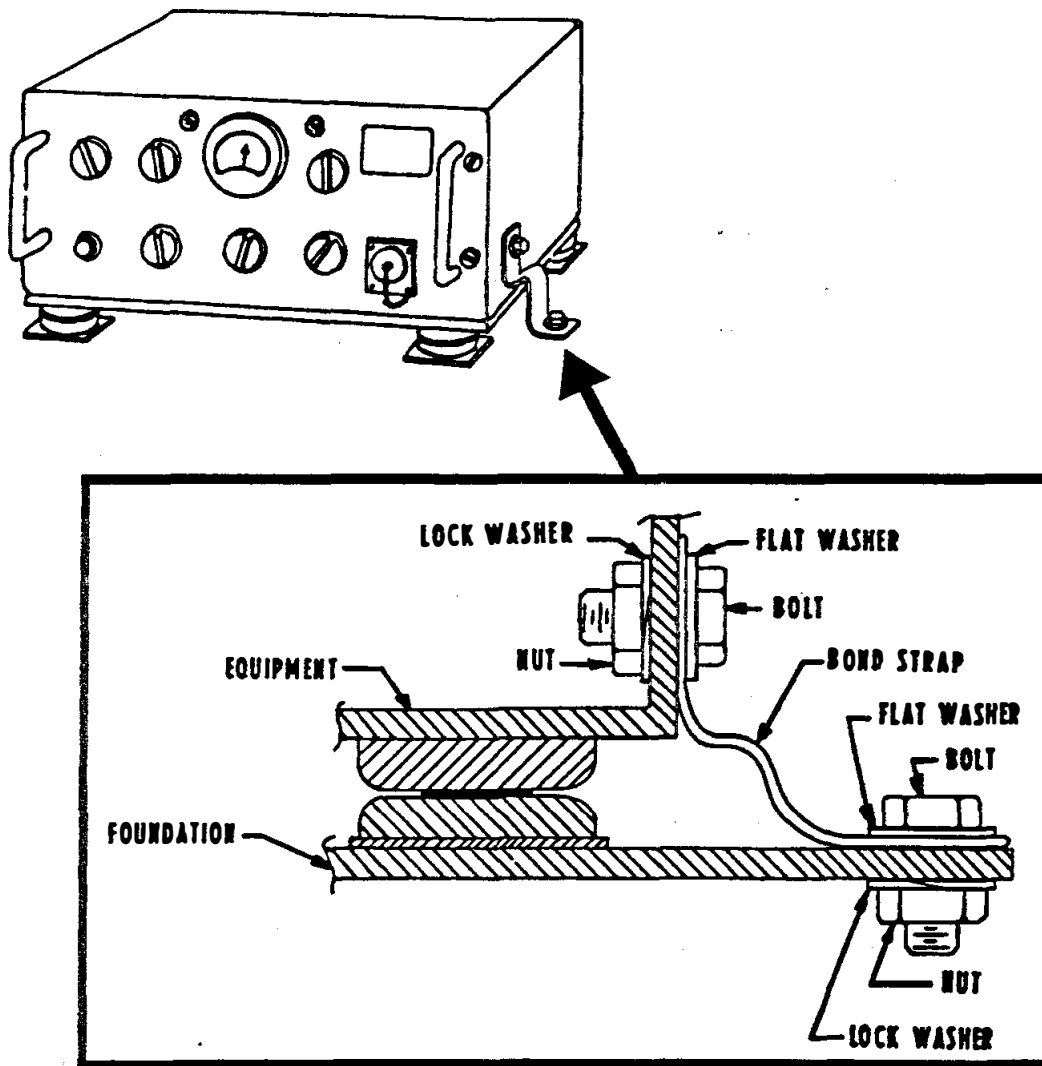

(U) FIGURE 6. Bonding of equipment cabinet to foundation.

UNCLASSIFIED

MIL-STD-1680C(SH)
17 March 1993

APPENDIX I

ILLUSTRATIONS

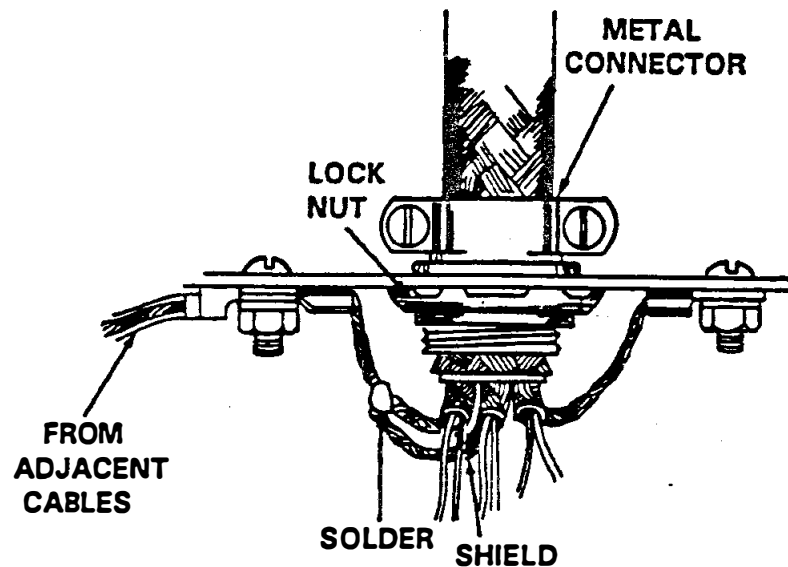

NOTES:

1. MAX NO OF SHIELDS PER LUG IS 6.
IF MORE THAN 1 SHIELD PER LUG,
SHIELDS SHALL BE SOLDERED IN
THE LUG.
2. MAX NO OF LUGS PER BOLT IS 4.
3. CABLE SHIELDS FOR SECURE VOICE
CIRCUITS TERMINATING ON BARRIER
TERMINAL STRIPS SHALL BE BONDED
TO GROUND AT THE TERMINAL STRIP
RATHER THAN AT THE POINT OF
CABLE PENETRATION.

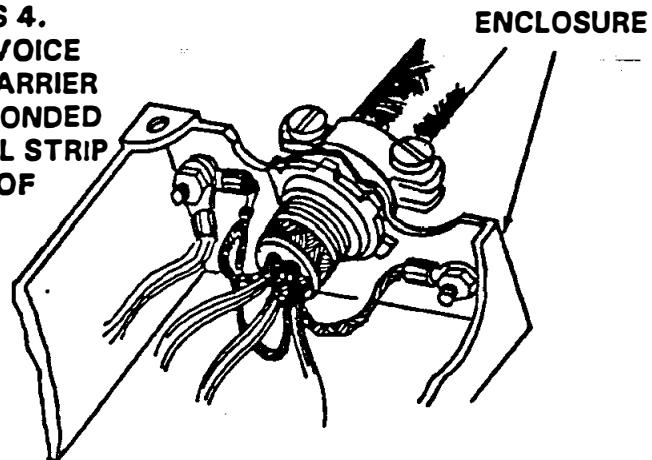

(U) FIGURE 7. Armor and Shield Bonding to Connector Box.

UNCLASSIFIED

MIL-STD-1680C(SH)
17 March 1993

APPENDIX I

ILLUSTRATIONS

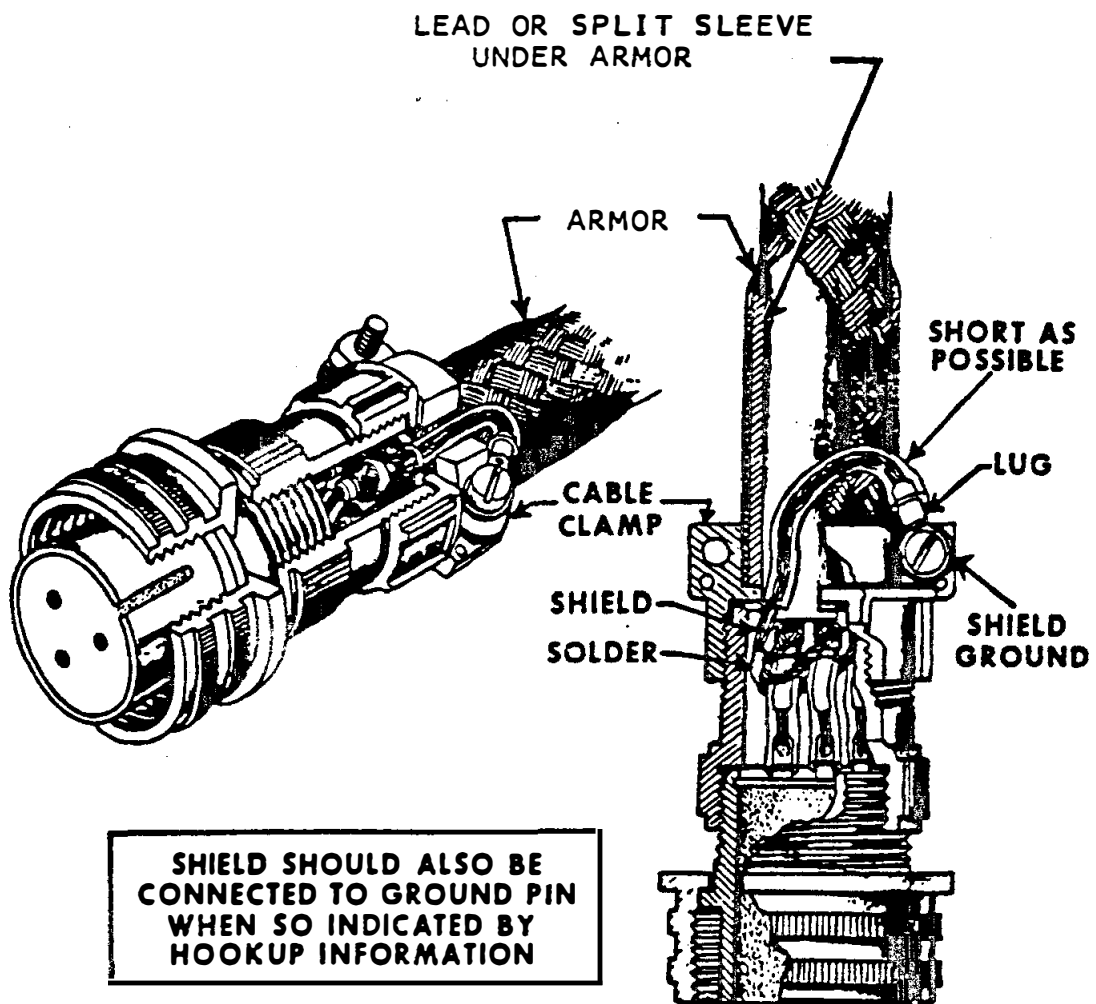

(U) FIGURE 8. Connector Plug Bonding.

UNCLASSIFIED

MIL-STD-1680C(SH)
17 March 1993

APPENDIX I

ILLUSTRATIONS

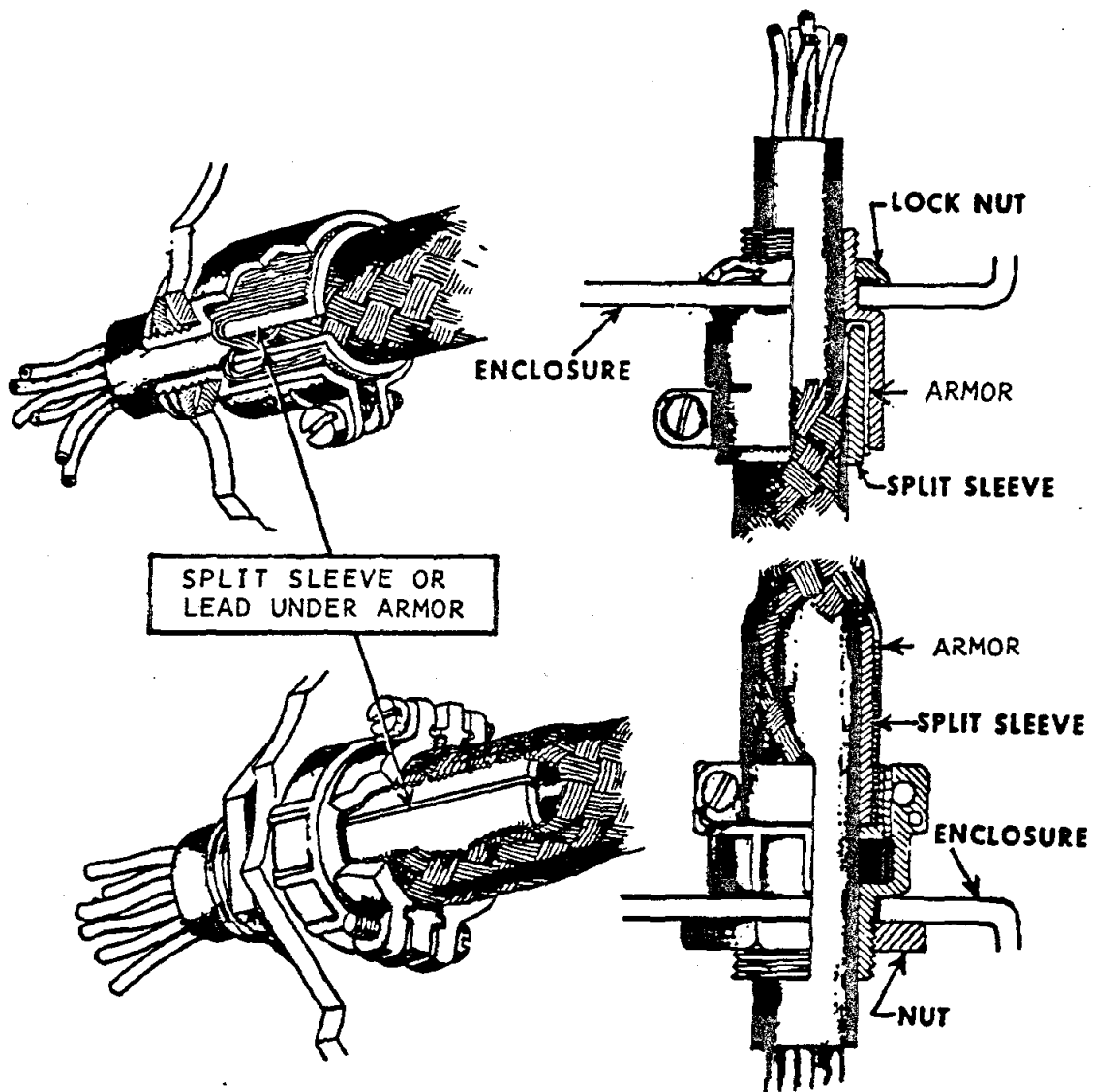

(U) FIGURE 9. Box Clamp and Connector Bonding.

UNCLASSIFIED

MIL-STD-1680C(SH)
17 March 1993

APPENDIX I

ILLUSTRATIONS

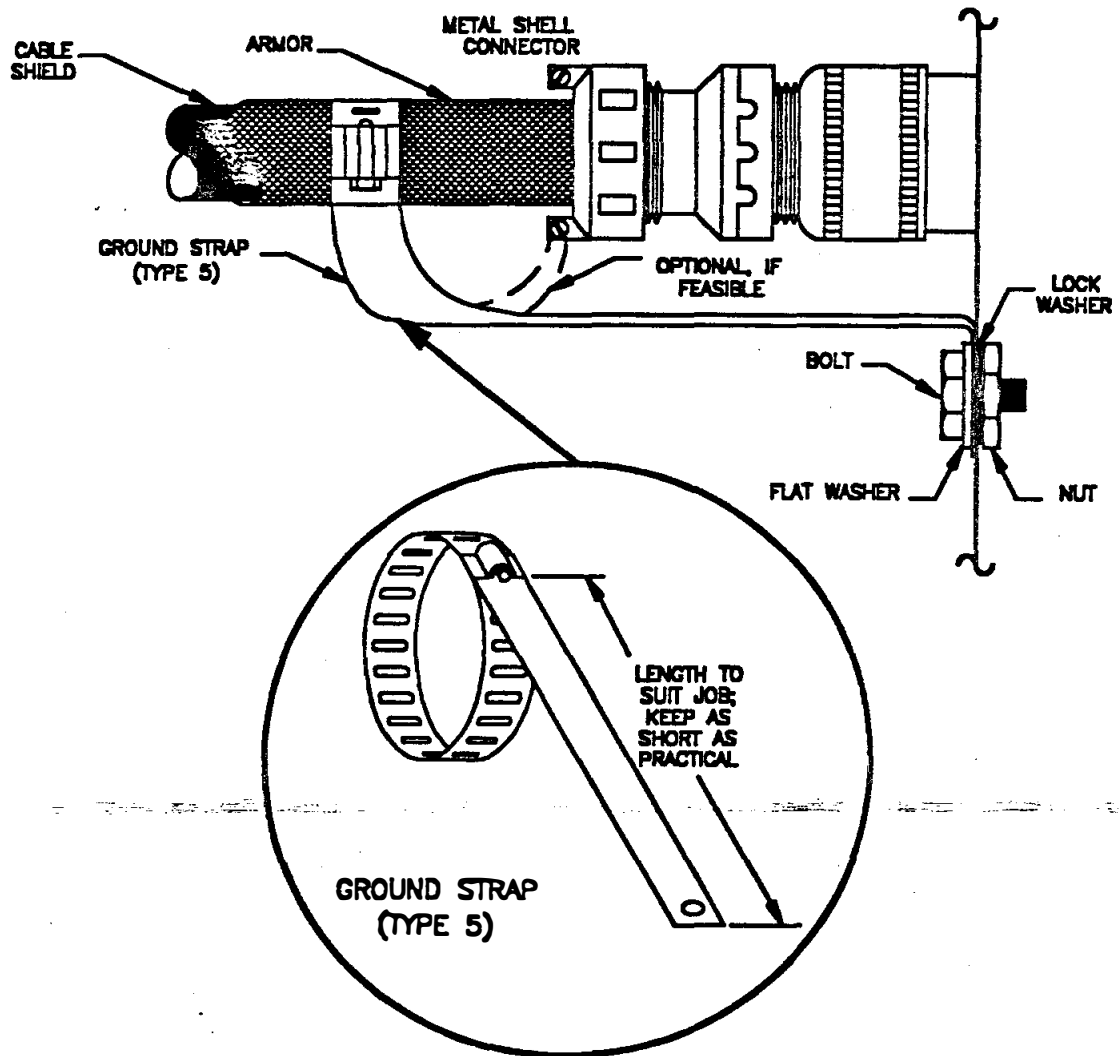

NOTE: CABLE SHIELD SHALL BE BONDED TO GROUND INSIDE CONNECTOR VIA A GROUNDED PIN IN THE CONNECTOR OR FORMED INTO A PIG-TAIL AND BONDED TO THE CONNECTOR BACKSHELL.

(U) FIGURE 10. Bonding of armor using connectors without stationary strain relief.

UNCLASSIFIED

MIL-STD-1680C(SH)
17 March 1993

APPENDIX I

ILLUSTRATIONS

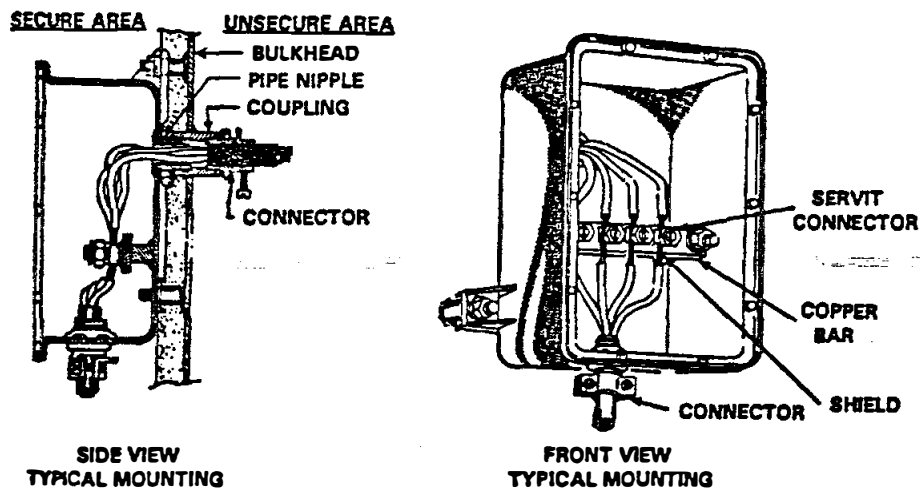
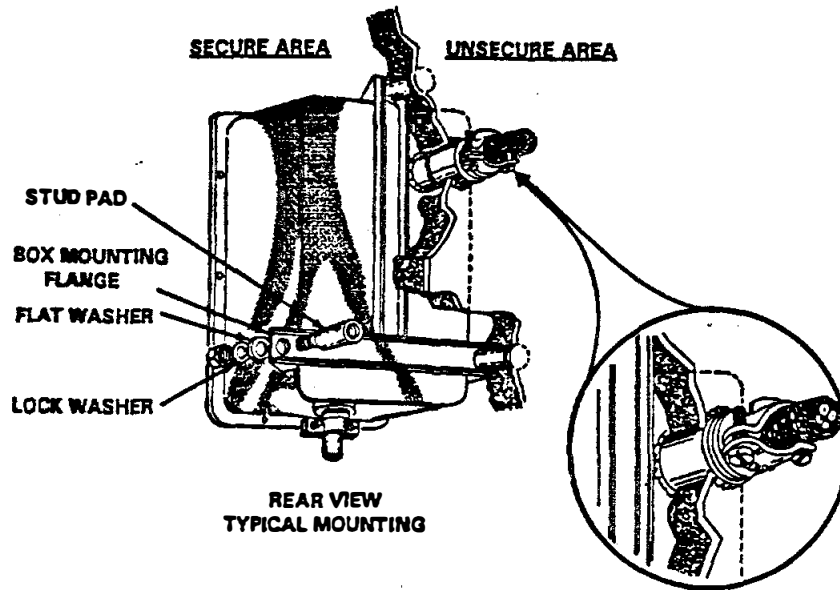

NOTE:
1. NOT MORE THAN 2 SHIELDS PER SERVIT CONNECTOR.

(U) FIGURE 11. Armor and Shield bonding to bulkhead penetration & box.

UNCLASSIFIED

MIL-STD-1680C(SH)
17 March 1993

APPENDIX I

ILLUSTRATIONS

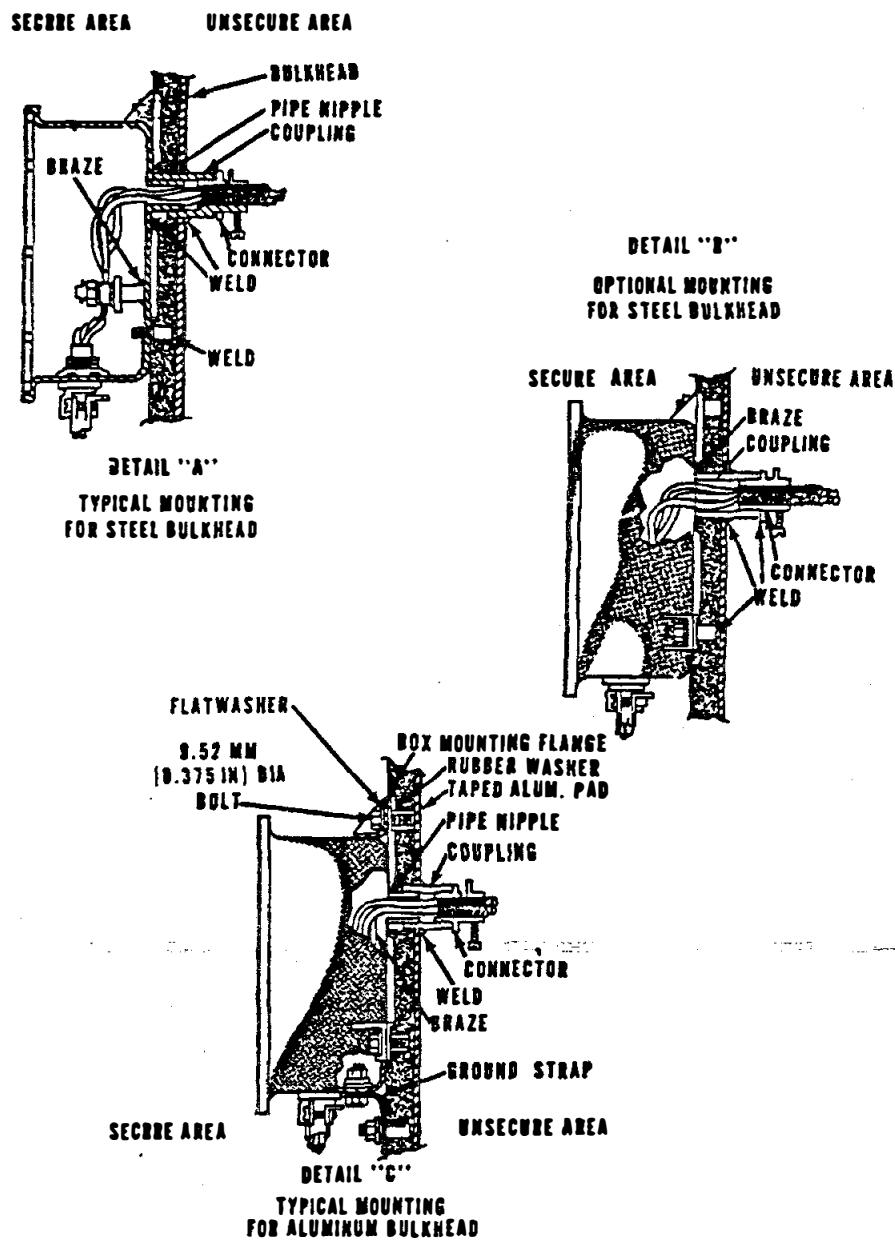

(U) FIGURE 12. Penetration box mounting and bonding details.

UNCLASSIFIED

MIL-STD-1680C(SH)
17 March 1993

APPENDIX I ILLUSTRATIONS

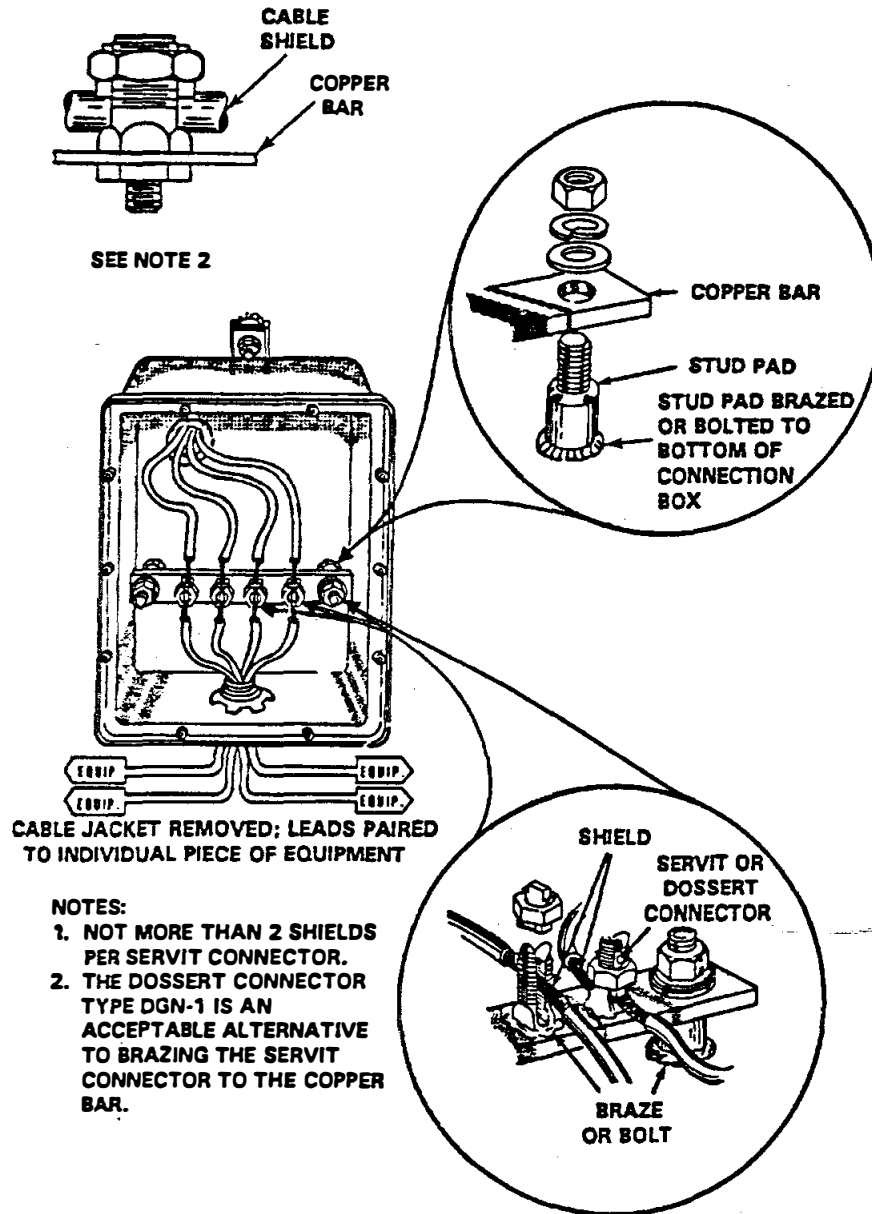

(U) FIGURE 13. Penetration box single bar details.

UNCLASSIFIED

MIL-STD-1680C(SH)

17 March 1993

APPENDIX I

ILLUSTRATIONS

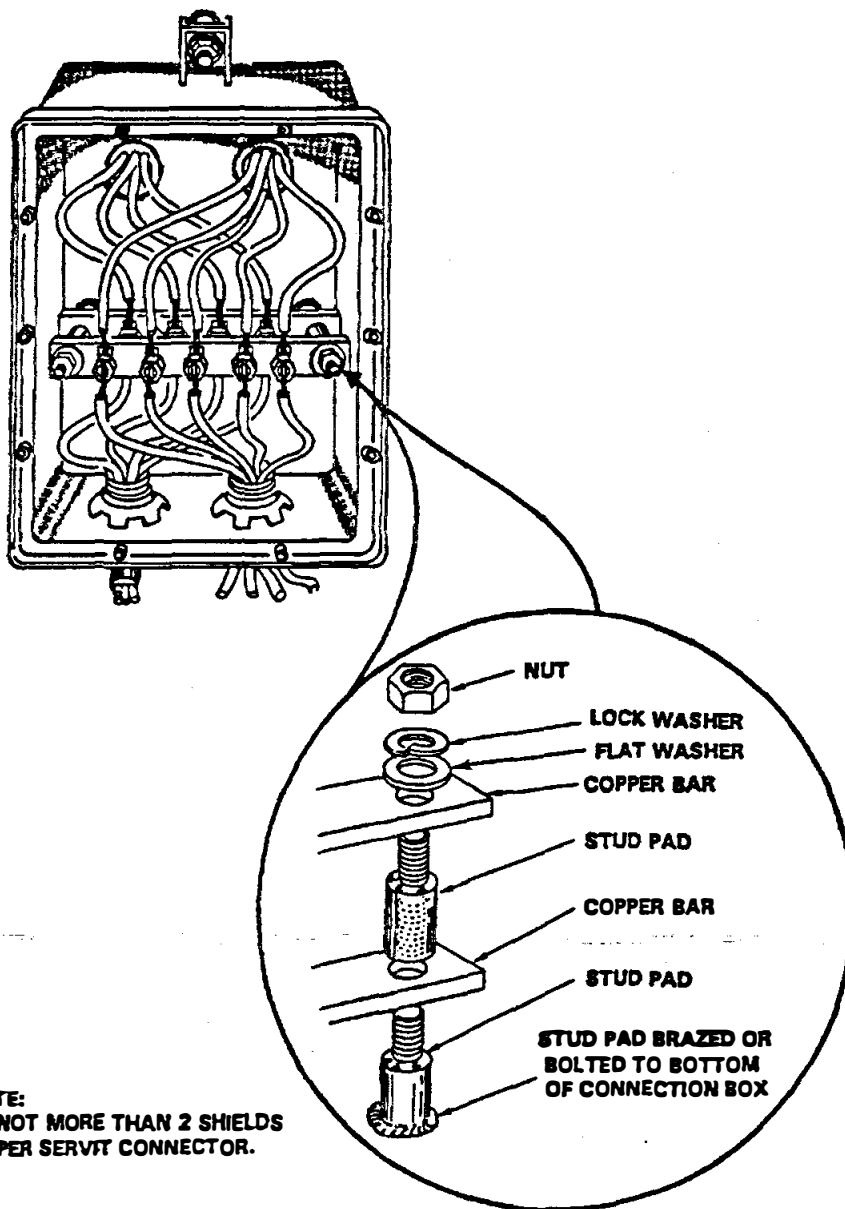

(U) FIGURE 14. Penetration box stacked bar details.

UNCLASSIFIED

MIL-STD-1680C(SH)
17 March 1993

APPENDIX I

ILLUSTRATIONS

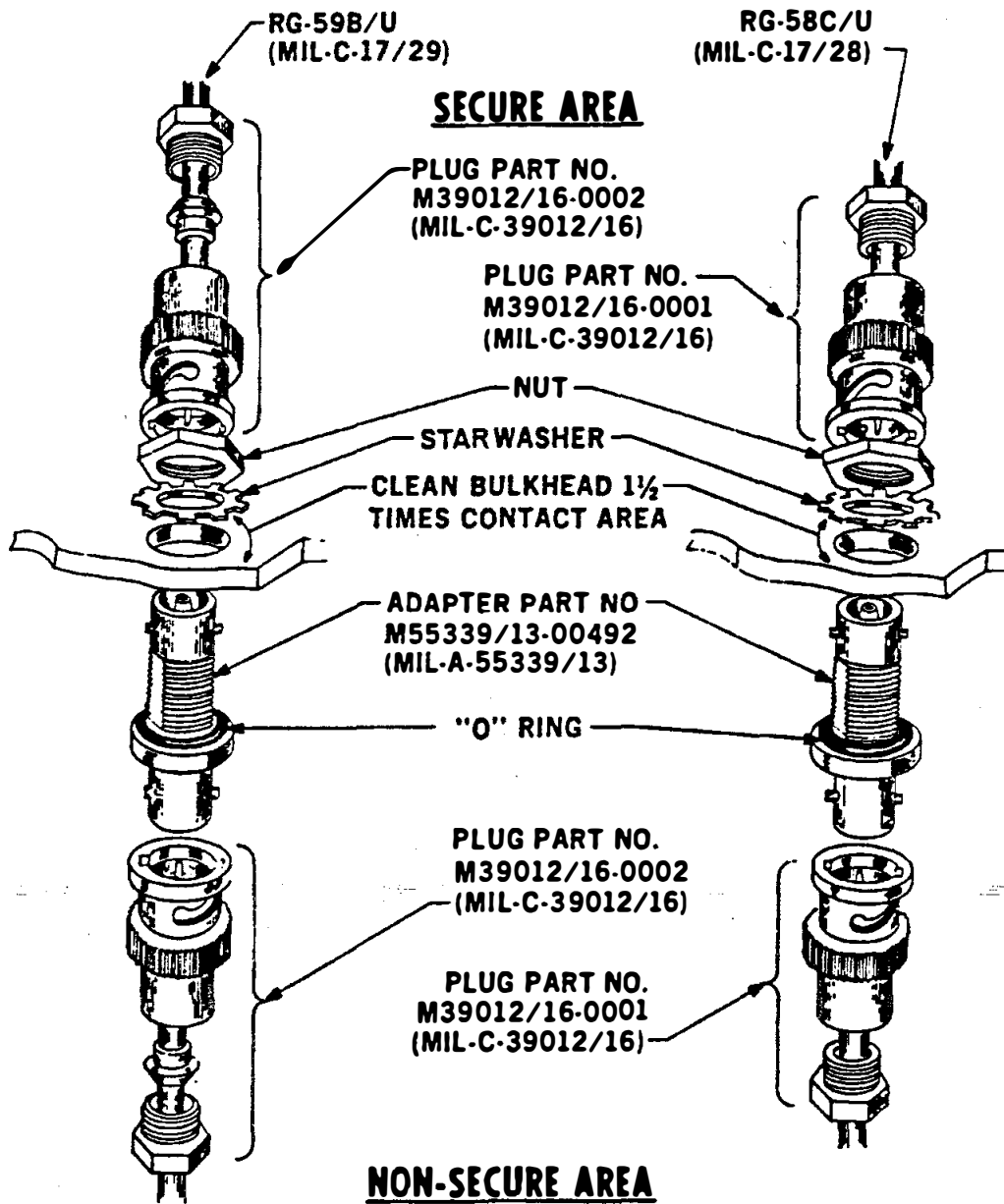

(U) FIGURE 15. Bulkhead penetration adapter.

UNCLASSIFIED

MIL-STD-1680C(SH)
17 March 1993

APPENDIX I

ILLUSTRATIONS

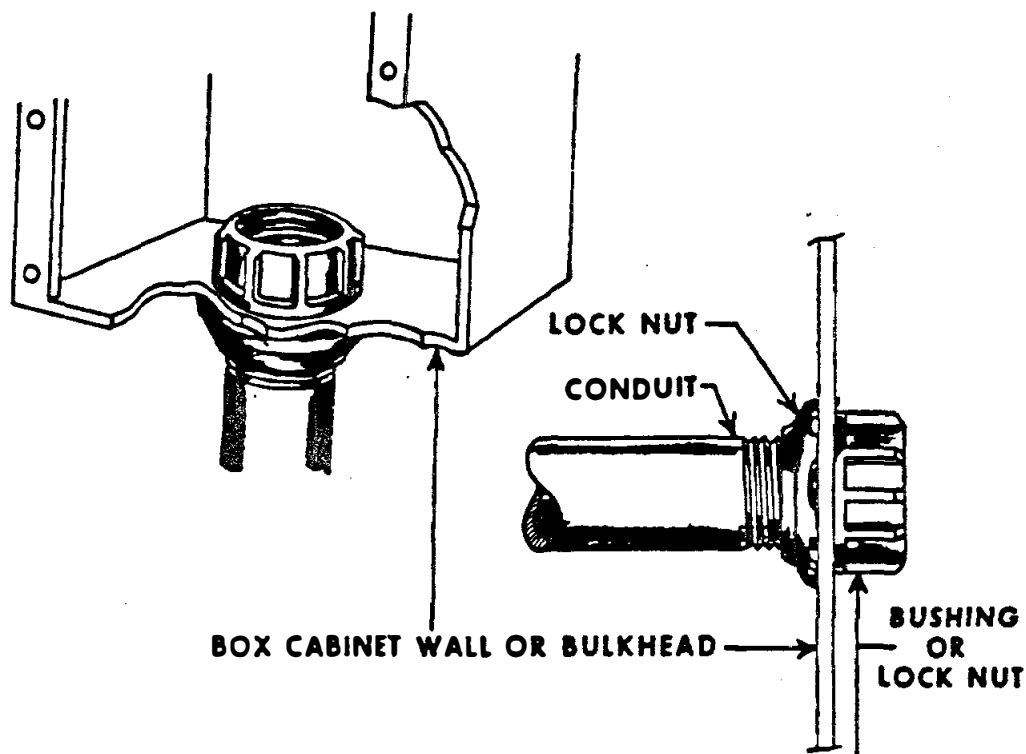

NOTE: A SECOND LOCK NUT MAY BE USED IF BUSHING NOT AVAILABLE. BUT CABLE SHALL BE PROTECTED AGAINST CHAFING BY USE OF ARMOR OR PLASTIC INSERT.

(U) FIGURE 16. Bonding of conduit via connectors.

UNCLASSIFIED

MIL-STD-1680C(SH)
17 March 1993

APPENDIX I ILLUSTRATIONS

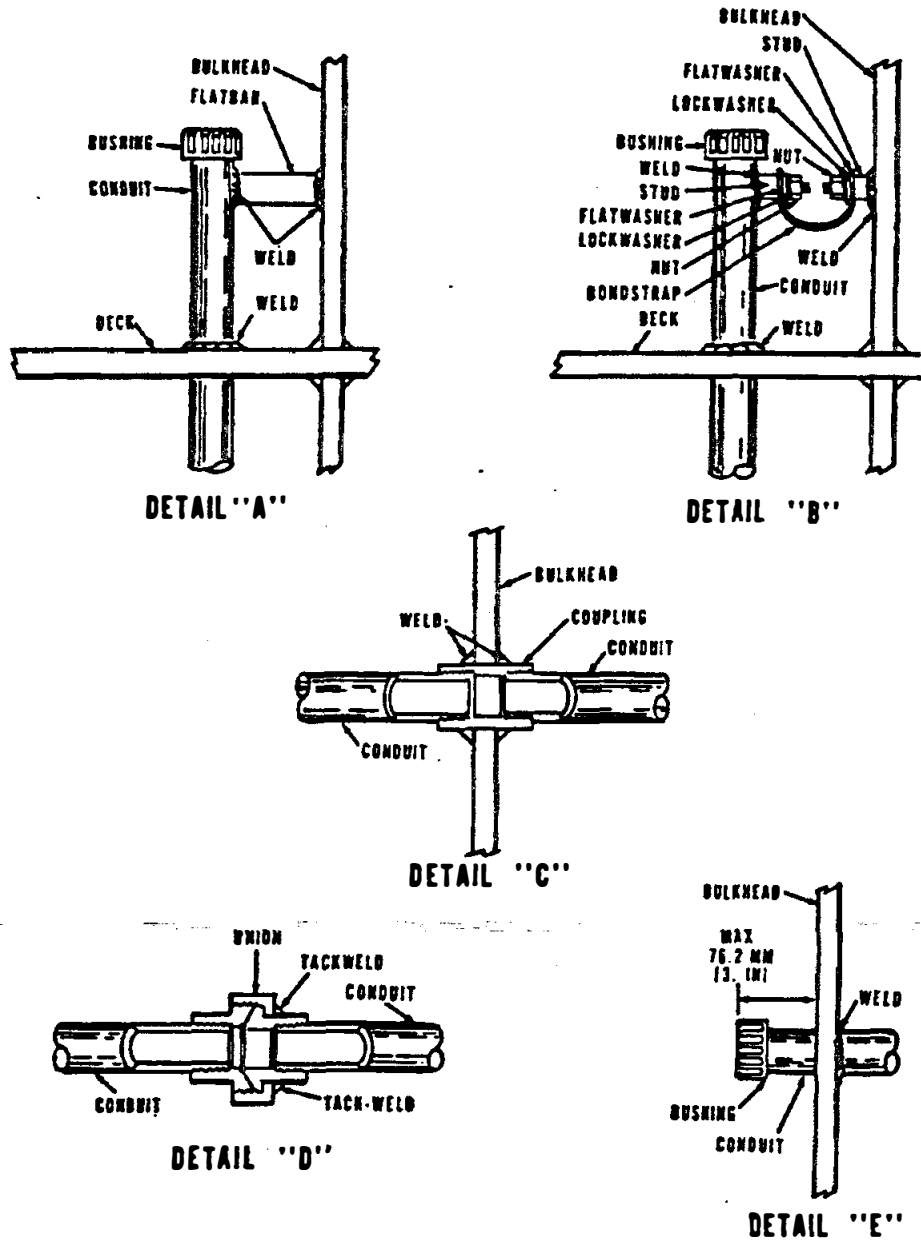

(U) FIGURE 17. Bonding of conduit via straps and weld.

UNCLASSIFIED

MIL-STD-1680C(SH)
17 March 1993

APPENDIX I ILLUSTRATIONS

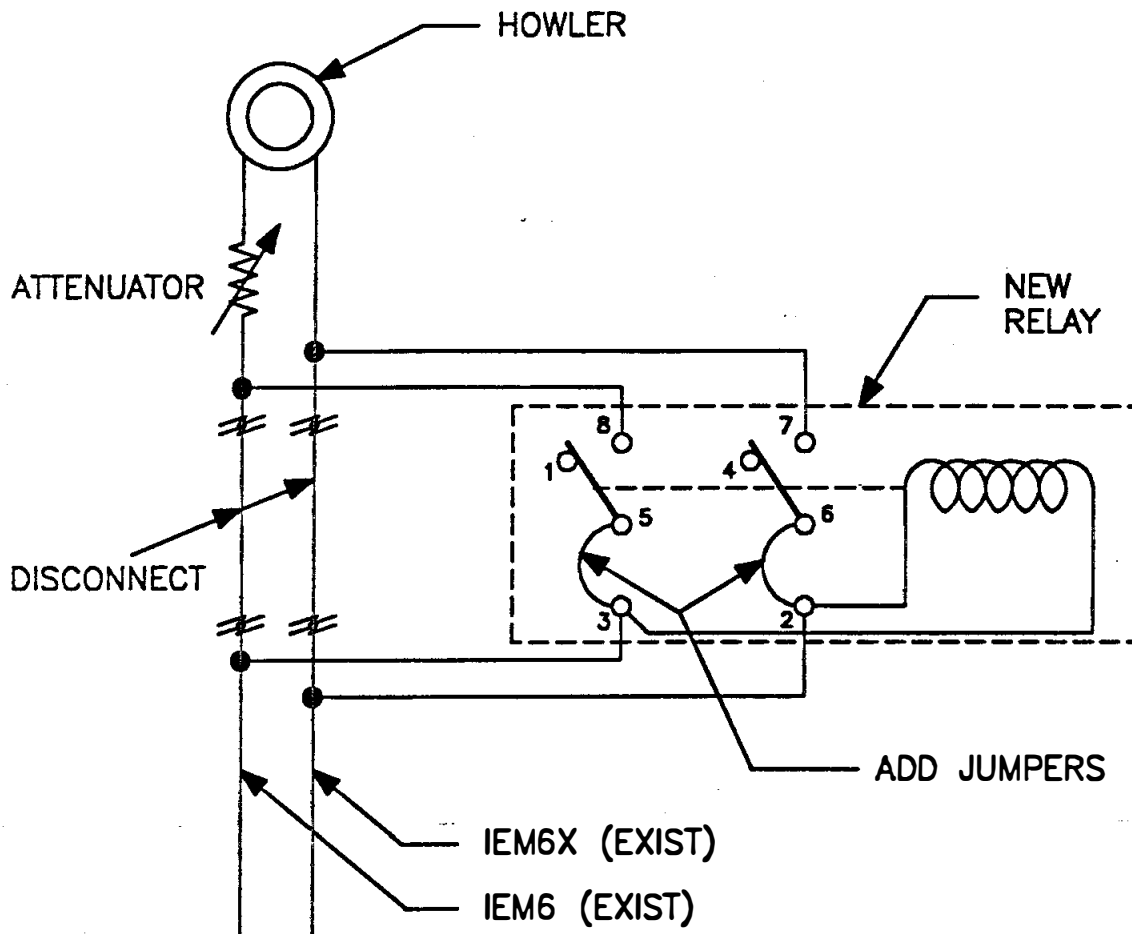

(U) FIGURE 18. Modification of call signal station, type IC/D.

UNCLASSIFIED

MIL-STD-1680C(SH)
17 March 1993

APPENDIX I

ILLUSTRATIONS

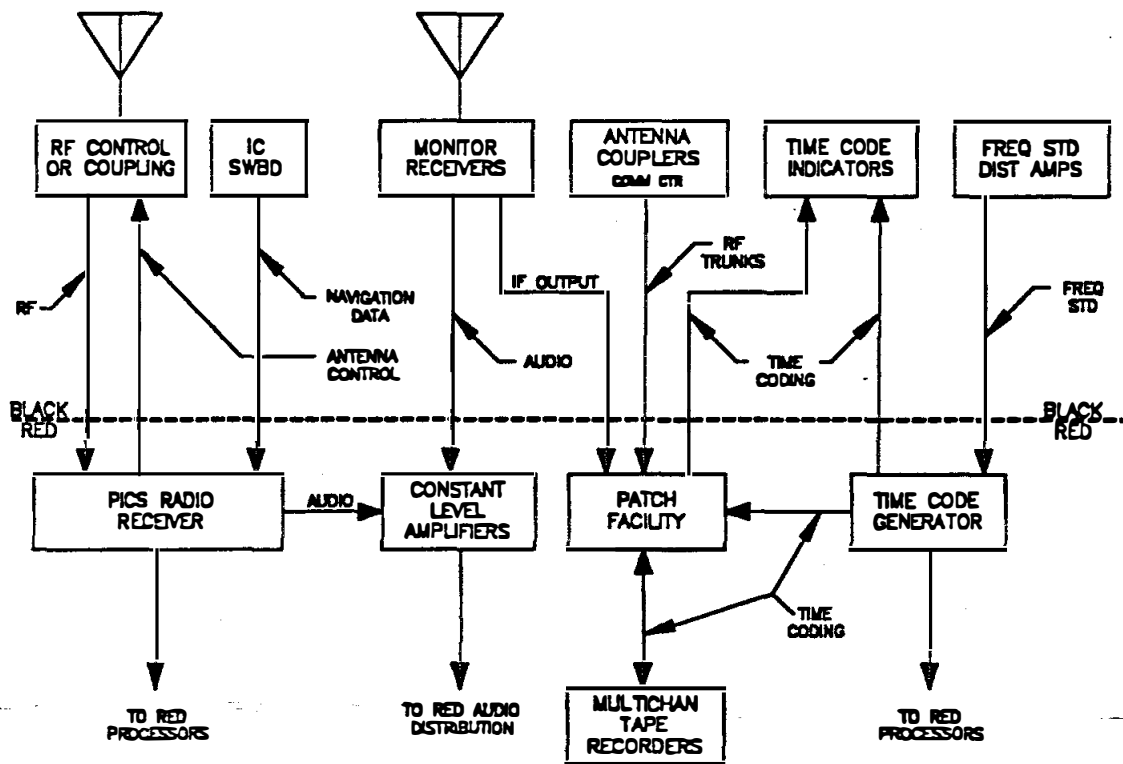

(U) FIGURE 19. PICS RED/BLACK signal interface.

UNCLASSIFIED

MIL-STD-1680C(SH)
17 March 1993

APPENDIX I

ILLUSTRATIONS

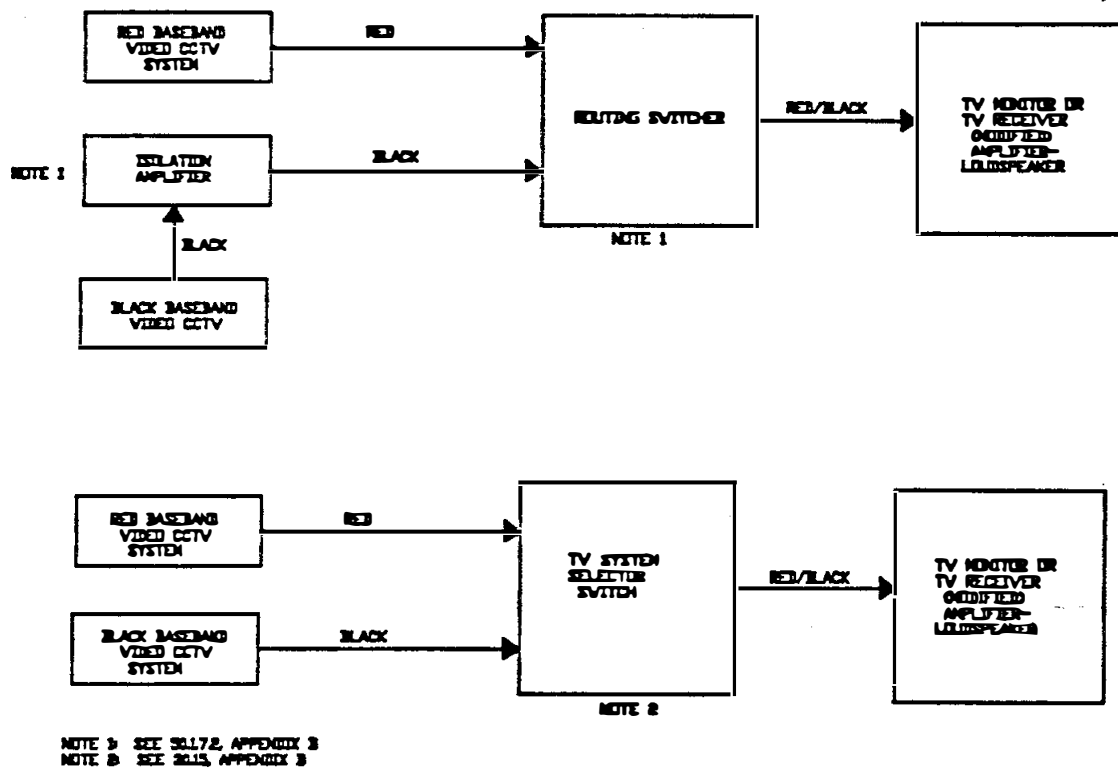

(U) Figure 21. RED and BLACK CCTV electrical signal distribution system interface.

UNCLASSIFIED

MIL-STD-1680C(SH)
17 March 1993

APPENDIX I

ILLUSTRATIONS

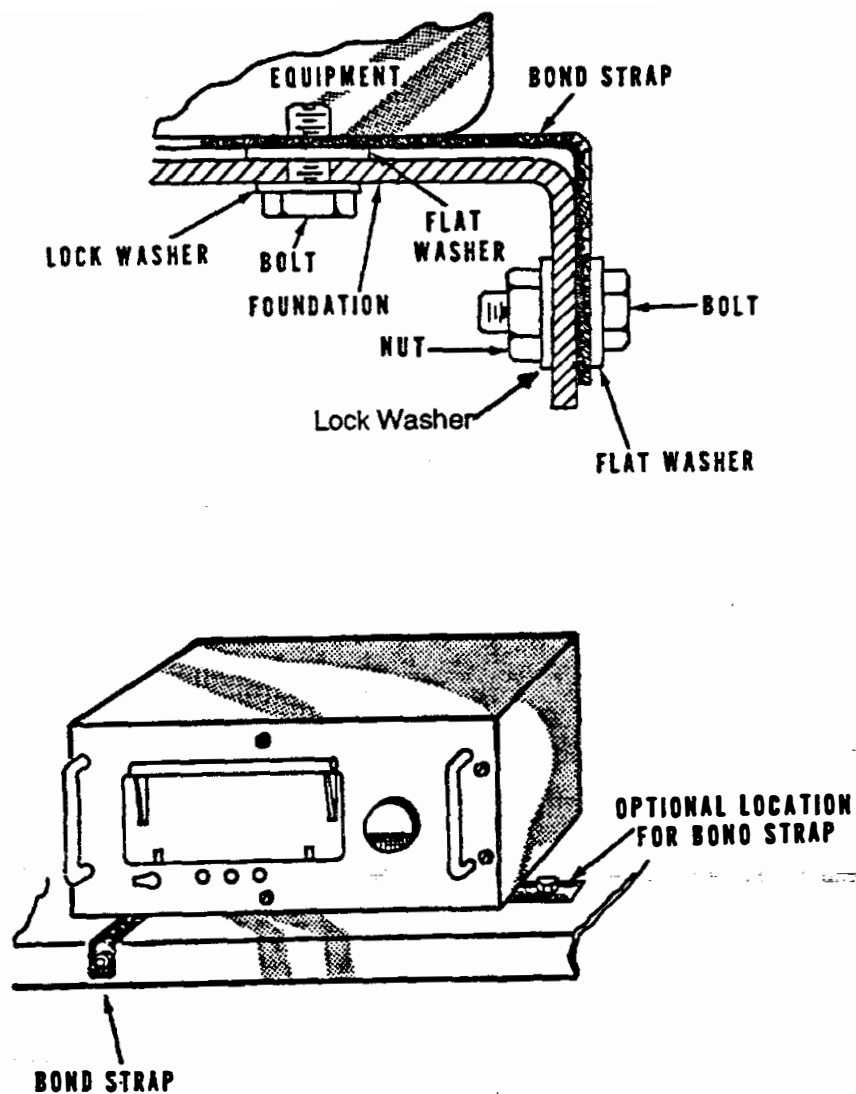

(U) FIGURE 22. Bonding of TSEC/KG-30 Family.

UNCLASSIFIED

MIL-STD-1680C(SH)
17 March 1993

APPENDIX J

MICRO/MINI COMPUTER SYSTEM

- * (U) 10. SCOPE
- * (U) 10.1 Scope. The following is the complete criteria to be applied to desk top and stand alone micro/mini computer systems that process classified information in ships.
- * (U) 20. APPLICABLE DOCUMENTS
- * (U) 20.1 Not applicable.
- * (U) 30. DEFINITIONS
- * (U) 30.1 Not applicable.
- * (U) 40. GENERAL REQUIREMENTS
- (U) 40.1 Purpose and coverage. Prior TEMPEST or NAVSEA approval is not required for use of any micro/mini computer system in metallic hull surface ships or submarines. Only desk top and stand alone micro/mini computer systems listed in paragraphs 50.1 or 50.2 of Appendix D or Endorsed TEMPEST Products List (ETPL) may be installed in non-metallic hull ships.
- * (U) 50. DETAILED REQUIREMENTS
- * (U) 50.1 General. The requirements of TEMPEST-related installation criteria and physical security installation criteria (see 50.2) are separately grouped.
- * (U) 50.1.1 Primary power. If the computer system is not listed in Appendix D, 50.1, 50.2 or 50.3 it shall be installed on RED primary power if RED power is available within the space. If not, the system may be installed on BLACK power, however the computer system shall not be powered from the same circuit breaker panel that powers BLACK modems or R.F. transmitters. This requirement is not applicable to non metallic hull ships.
- * (U) 50.1.2 Shielded cables. Locally fabricated RED shielded cables shall be in accordance with 5.2.11. Cables interconnecting the computer components which are provided by the manufacturer should be shielded if available; otherwise, the unshielded cables may be used without modification.

UNCLASSIFIED

MIL-STD-1680C(SH)
17 March 1993

APPENDIX J

MICRO/MINI COMPUTER SYSTEM

- * (U) 50.1.3 Grounding. The power cable shall have a third wire or safety ground. No other ground is required for the system unless the equipment has provisions for installation of a bond strap, in which case a bond strap shall be installed.
- * (U) 50.1.4 Cable grounding. Locally fabricated RED shielded cable shall be bonded to ground in accordance with paragraph 5.2.14.19.
- * (U) 50.1.5 Interconnection. Computer systems interconnected to other CLIPS shall be in accordance with this standard. (See 5.1.1 and 5.3.5.1.1)
- * (U) 50.1.6 Electrical Perimeter Barrier. The compartment in which the computer system is installed shall comprise an electrical perimeter barrier as defined in 3.14. When processing classified information, there shall be a sign stating "DOOR NOT TO BE LEFT OPEN WHEN PROCESSING CLASSIFIED INFORMATION" visibly posted on the inside of the space adjacent to the door. This requirement does not apply to non metallic hull ships.
- * (U) 50.1.7 Separation. The computer system shall be installed a minimum of 3 feet from BLACK signal processors such as the following:
 - a. Radio transmitters and transceivers.
 - b. BLACK Modems and other modulating devices, such as AN/UCC-1(V) and CV-2460/SGC.
 - c. P/C radiotelephones with unfiltered transmit audio lines (see 5.1.11.5).
 - d. Transfer switchboards having a direct connection to radio transmitters or transceivers, such as transmitter transfer, receiver transfer, frequency selection transfer, data transfer and FSK/RFCFS.
 - e. A BLACK teletypewriter equipment with a send capability.
 - f. Control units used with radio transmitters or transceivers, such as C-1004()/SG and C-9351/WSC-3(V).

UNCLASSIFIED

MIL-STD-1680C(SH)
17 March 1993

APPENDIX J

MICRO/MINI COMPUTER SYSTEM

* (U) 50.2 Physical security. Storage shall be provided for classified discs and tapes used with the system. If classified information is resident in the computer when the compartment is unmanned, the compartment shall be designated a secure remote area and meet the physical security requirements for that type space.