

# **RECEIVERS**

## **FUNDAMENTALS AND SERVICING**

### **COURSE 601**

**NAVAL RADIO MATERIEL TRAINING PROGRAM**

1. The first part of the document discusses the importance of maintaining accurate records of all transactions and activities. It emphasizes that this is essential for ensuring transparency and accountability in the organization's operations.

2. The second part of the document outlines the various methods and tools used to collect and analyze data. It highlights the need for consistent and reliable data collection processes to ensure the validity of the results.

3. The final part of the document provides a summary of the key findings and conclusions. It reiterates the importance of ongoing monitoring and evaluation to ensure the organization remains effective and efficient.

**RESTRICTED**

**RECEIVERS**  
**(FUNDAMENTALS AND SERVICING)**  
**COURSE 601**

**NAVAL TRAINING SCHOOL**  
**(RADIO MATERIEL)**  
**TREASURE ISLAND**  
**SAN FRANCISCO, CALIFORNIA**

**December 1945**



A **MODULATED** wave is one in which the amplitude, frequency or phase of a periodic wave carrier is varied in accordance with a modulating signal.

**MODULATION** is the process by which the variation is accomplished.

**DEMODULATION** or **DETECTION** is the process by which the original modulating signal is recovered from the modulated carrier wave. Any **NON-LINEAR** impedance may be used for detection.

An amplitude modulated wave contains the following frequencies:

- (1) The carrier frequency.
- (2) The upper sideband frequency. (carrier plus modulating frequency)
- (3) The lower sideband frequency. (carrier minus modulating frequency)

The RF and IF stages preceding the detector must be able to pass the carrier and both sideband frequencies without attenuation.

## DETECTOR CHARACTERISTICS

1. **SENSITIVITY:** The ratio of the peak to peak audio swing to the amplitude variation of the modulation envelope. It is a measure of detector gain.
2. **SELECTIVITY:** A measure of the ability of the circuit to pass desired signals and reject undesired signals.
3. **FIDELITY:** A measure of the ability of the detector to reproduce the **EXACT** form of the modulation in the audio frequency output.
4. **NORMAL SIGNAL STRENGTH:** The input signal strength with which the detector is normally used.

Typical diode detector circuits are shown below:

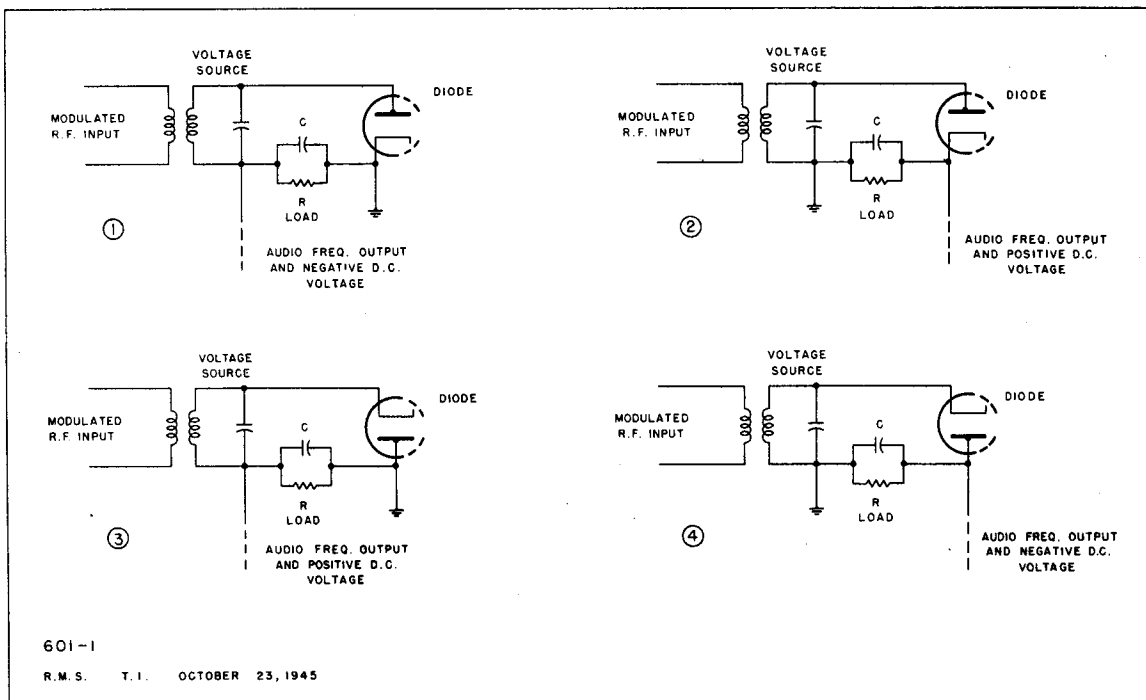

## RECEIVERS

Arrangement #1 is generally used because it offers all the following advantages:

1. A negative DC voltage is available for use as an automatic volume control.
2. The cathode is at ground potential reducing hum pickup caused by leakage between cathode and filament.
3. The circuit is easily adapted to the use of multi-purpose tubes as detectors and audi amplifiers.

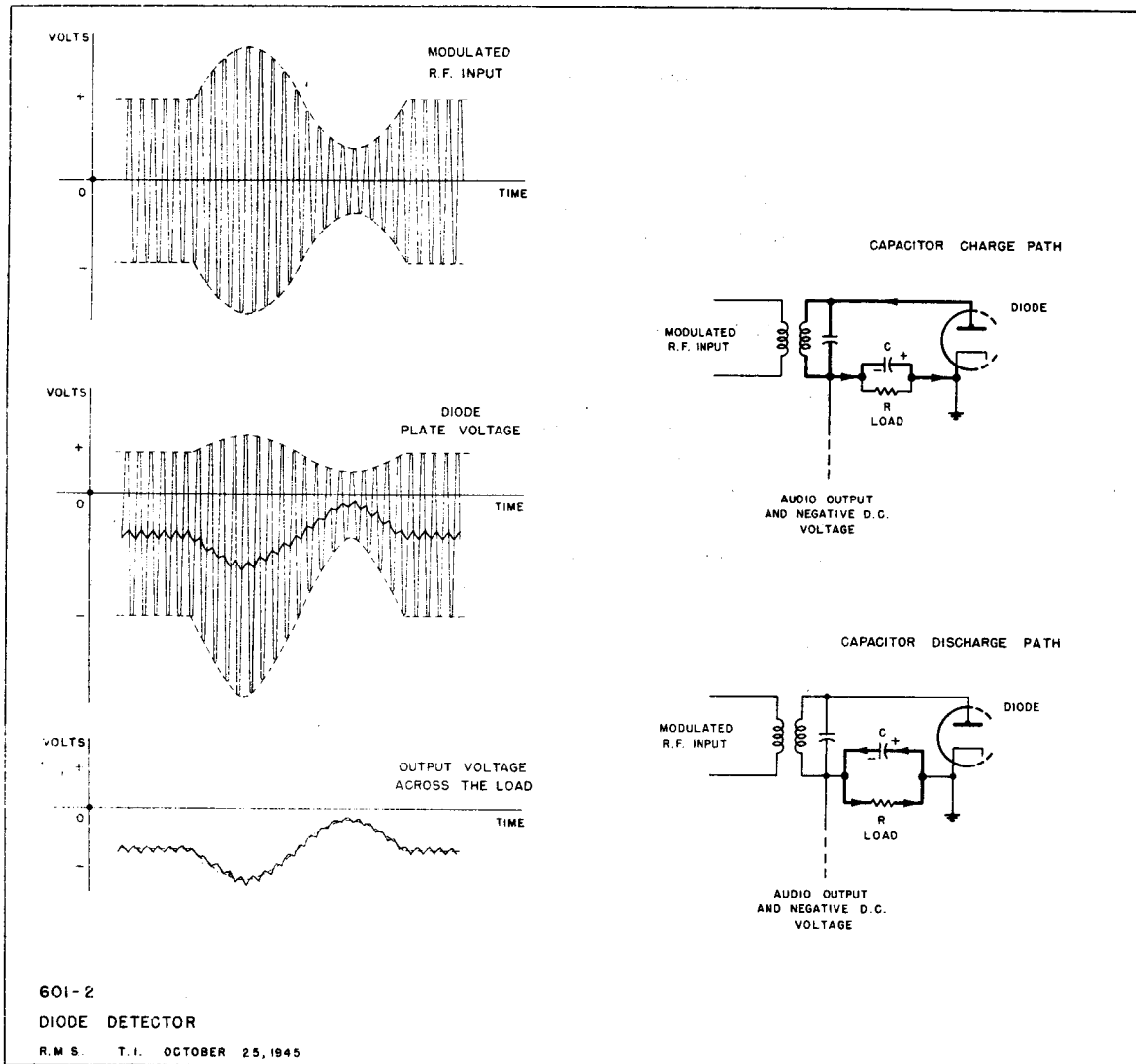

## DIODE DETECTOR CHARACTERISTICS

1. **SENSITIVITY:** Poor. Detector gain is less than one.
2. **SELECTIVITY:** Poor. Diode conduction current loads the tuned circuit.
3. **FIDELITY:** Good. Distortion may be kept very low by the use of large signal amplitude and by careful choice of circuit component values.
4. **NORMAL SIGNAL STRENGTH:** Strong. The diode is able to stand large voltages.

On the positive RF signal swing, C charges through the diode and the tank circuit. The sum of these two impedances is less than the value of R (Fig. 601-2). When the RF signal drops from the peak value, C discharges slightly through the large resistance, R. A negative voltage is thus maintained on the diode plate until nearly the peak of the next RF cycle. When the positive RF swing overcomes the voltage across C, the diode will conduct recharging C. The charge across C must leak off sufficiently before the next RF pulse in order that the bias voltage will follow the carrier envelope at its maximum slope. These relationships are illustrated in Fig. 601-2.

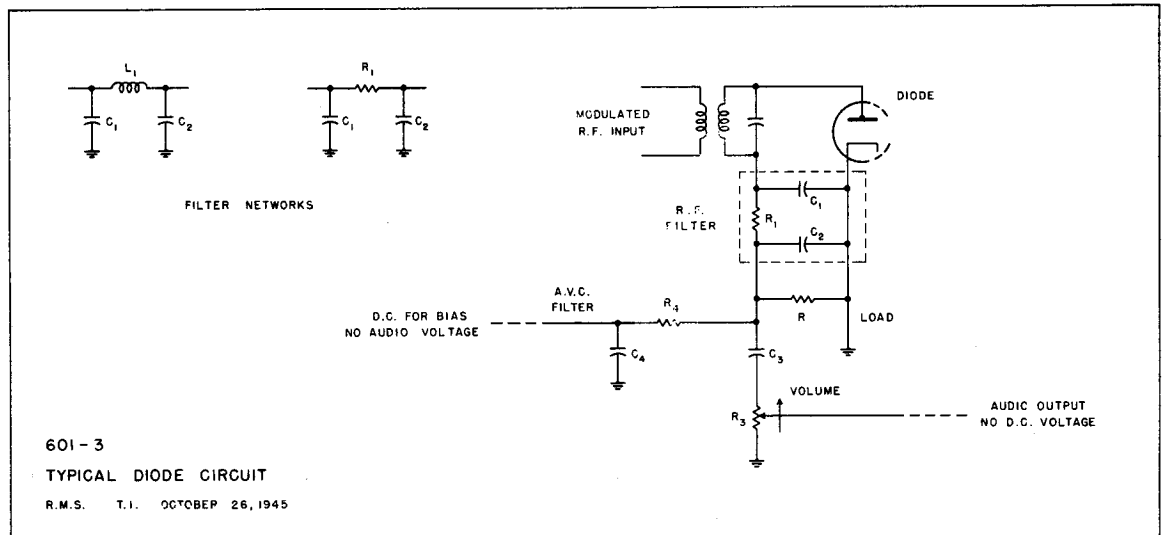

The RF ripple present in the output of the Diode Detector might be coupled to other stages resulting in undesired oscillations. Such oscillations may be prevented by the use of shielding and an RF filter network such as illustrated in Fig. 601-3. A low pass filter will allow the modulation frequency to pass and will shunt the RF to ground. The Capacitors, C1 and C2, should have low reactance at radio frequencies and high reactance at the modulation frequencies. The series RF choke or resistor should have much higher impedance at the RF than C1 or C2. The maximum size of the resistor is limited by the amount of audio frequency loss that may be sacrificed for the purpose of filtering out the RF.

Fig. 601-3 shows the diode detector with the addition of an RF filter, and AVC filter and an audio output coupling network. Both C3 and C4 charge to the average negative voltage across the load resistor R. On the modulation trough C3 and C4 will attempt to discharge through R3 and R4 respectively. This discharge current would place a negative voltage on the diode plate preventing conduction for a number of RF cycles in the trough of the modulation envelope. This would result in clipping off the part of the audio cycle which corresponds to the trough or negative modulation peak. Such distortion is called **NEGATIVE PEAK CLIPPING**. In order to minimize the magnitude of this effect, the resistors R3 and R4 are made many times larger than the value of the load resistor R.

## RECEIVERS

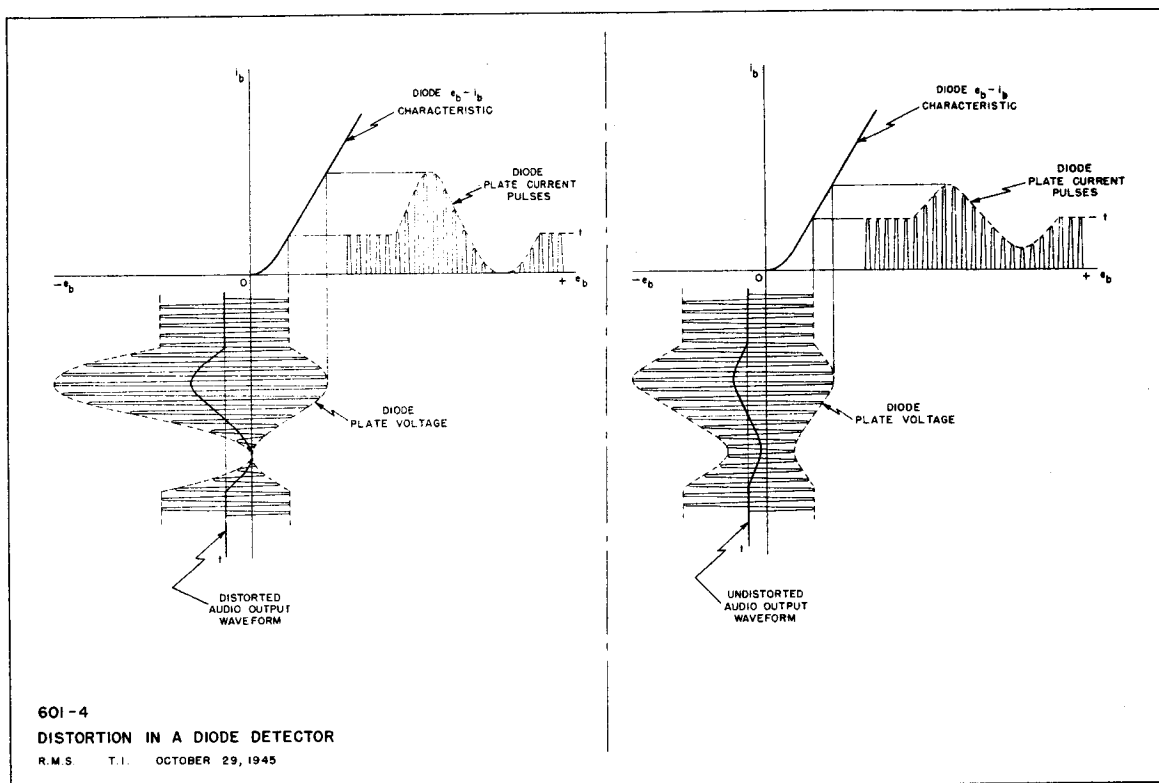

The diode plate voltage plate current characteristic is essentially linear over a considerable portion of its extent. However, there is a marked curvature of the characteristic for very low plate currents. This curvature of the characteristic causes distortion of the audio output. When the carrier amplitude is small, as with weak signal reception, this distortion is very marked for all percentages of modulation. Increasing the amplification of the signal ahead of the diode detector will then reduce the percent distortion produced in the system.

Distortion will always be encountered if the modulation factor approaches one, as under this condition the trough of the modulation cycle always reaches the curved portion of the diode characteristic.

Distortion resulting from curvature of the diode characteristic may be practically eliminated by the use of large signal amplitude and modulation factors of eight tenths or less.

The diode plate resistance, in the conduction region, varies appreciably, but its magnitude is never very large. The use of a large resistance for the diode load will then make the percentage variation of the TOTAL resistance fairly small. For this reason, increasing the size of the diode load resistor is effective in reducing the distortion resulting from the curved diode plate voltage plate current characteristic.



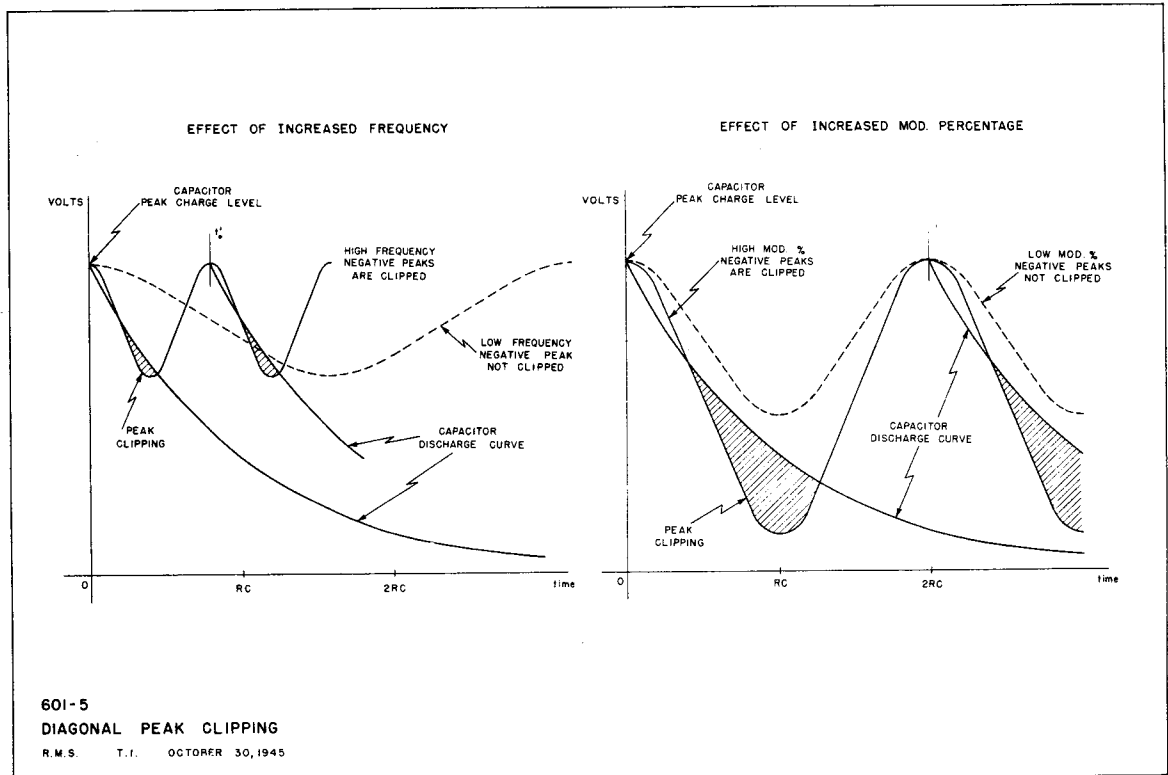

### DIAGONAL PEAK CLIPPING

It is necessary that the diode load resistor be bypassed for the RF signal. Also in order to increase the efficiency of detection it is desirable to make the diode load resistor as large as possible. There are practical limits imposed upon the size of both resistor and capacitor which are a compromise between increased efficiency of detection and increased distortion. The bypass capacitor should be of the same size as the capacitor resonating the secondary of the transformer driving the diode. When this condition is met there is a maximum transfer of energy from the transformer to the diode and its load. With the size of the capacitor determined in this manner, increasing the value of the diode load resistor will increase the time constant of the capacitor discharge circuit until this rate of discharge may not be great enough to follow the modulation envelope at its steepest rate of change. If this condition is encountered, diagonal peak clipping will result and the audio output will be distorted.

The rate of discharge is determined by the time constant of the load resistor and its bypass condenser. The rate of change of the modulation envelope increases with increasing modulation frequency and modulation index. Therefore the effects of diagonal peak clipping are most pronounced for high percentages of modulation and for high frequencies. These considerations impose an upper limit on the value of the diode load resistor. Its value should be so chosen that no diagonal peak clipping results when the highest modulation frequency to be handled by the system has a modulation index of about eight tenths.

## RECEIVERS

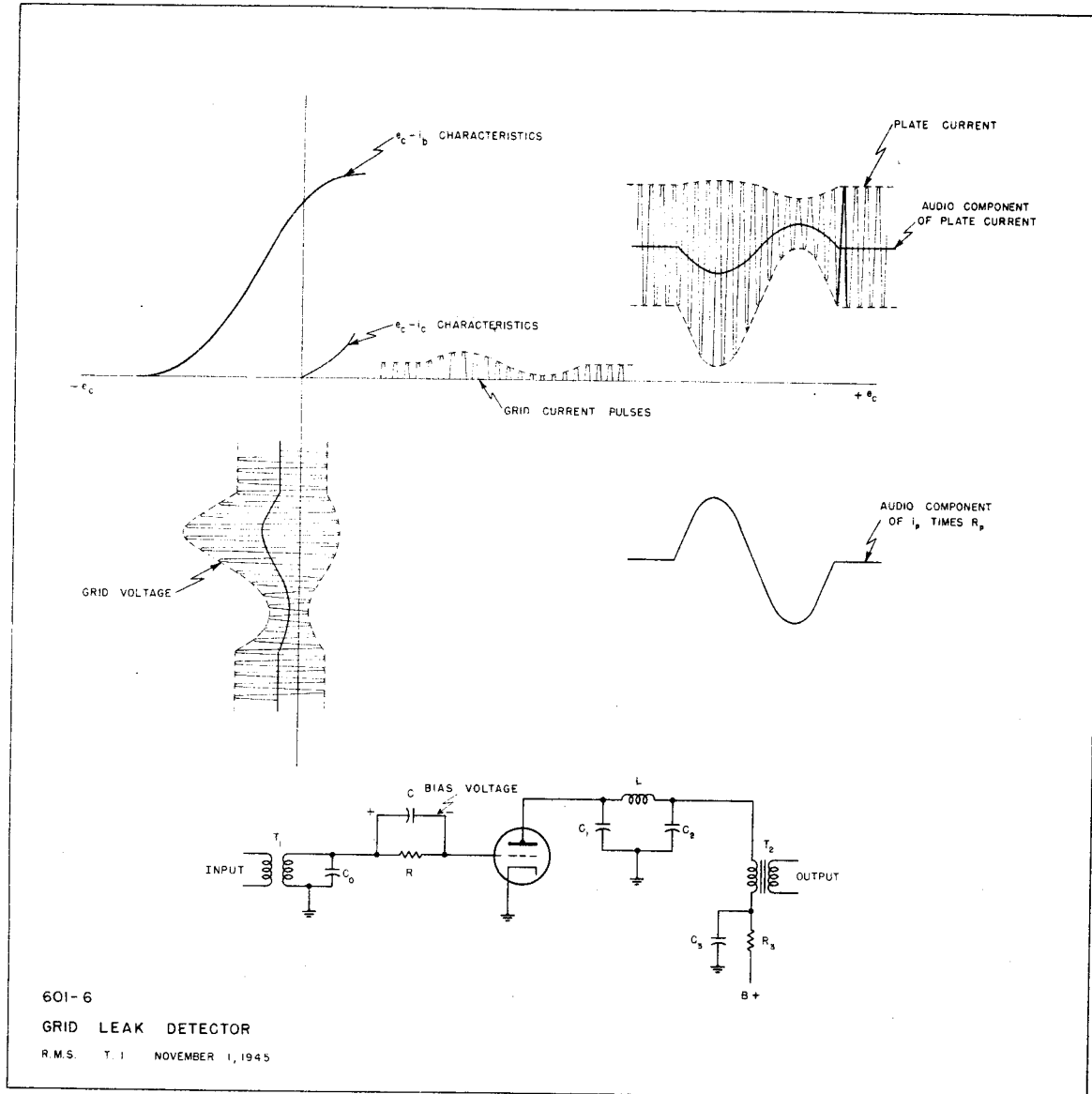

## GRID LEAK DETECTOR

1. **SENSITIVITY:** Very good. Amplification after detection may be very high.
2. **SELECTIVITY:** Fair. Grid current flow produces some loading of the grid tank.
3. **FIDELITY:** Poor. Considerable distortion results from detection on the curved grid voltage grid current characteristic and amplification on the curved portion of the grid voltage plate current characteristic. The circuit is also subject to diagonal peak clipping and to blocking on strong signals.
4. **NORMAL SIGNAL STRENGTH:** Weak. This detector is easily overdriven, producing severe distortion.

**OPERATION:**

The circuit elements in the grid circuit of the grid leak detector act in substantially the same manner and are determined by the same factors as are the corresponding circuit elements in the diode detector. The GRID CIRCUIT of the grid leak detector acts as a DIODE DETECTOR. The non-linear grid voltage grid current characteristic is quite pronounced and considerable distortion results from detection in the grid circuit. The signal which has been detected in the grid circuit is then amplified in the plate circuit. The bias on the grid is only that resulting from the rectification in the grid circuit and is generally small. This places the operating point of the tube on a curved portion of the grid voltage plate current characteristic and distortion is thus produced in the amplification process. If the RF signal strength is great enough, the negative peaks of the instantaneous grid voltage swing will extend into the lower curved portion of the tubes grid voltage plate current characteristic. When this happens, partial plate detection results. This reduces the audio output voltage and aggravates the distortion.

**LIMITATIONS:**

In the absence of a signal, the grid current is zero. The detector is then operating with zero bias. For this reason the plate voltage in the case of a triode or the screen voltage in the case of a pentode must be kept low. This limits the useful plate swing. The range may be extended by operating the detector from a high voltage supply and using resistance coupling or by using transformer coupling and inserting a resistor in series with the load and bypassing it for audio frequencies. This is the function performed by C3 and R3 of Fig. 601-6. The carrier frequency components of the plate current are filtered out by the action of the RF filter, L, C1 and C2.

**DISTORTION FACTORS:**

The grid leak detector is particularly subject to distortion. Since the grid circuit is the same as a diode circuit it suffers from the same inherent faults. The grid leak detector is subject to diagonal peak clipping, and to distortion due to operation over the curved portion of the grid voltage grid current characteristic. Also strong signals, by increasing the average bias, will block the tube over a portion of the modulation cycle, causing severe distortion. The grid leak detector is essentially a weak signal detector. This means that the bias rectified in the grid circuit will be small and the operating point of the tube will be at the upper curved portion of the grid voltage plate current characteristic. Further distortion is then introduced in the amplification process. Signals strong enough to swing the grid to the lower curved portion of the grid voltage plate current characteristic will also cause partial plate detection reducing the output and increasing the distortion.

## RECEIVERS

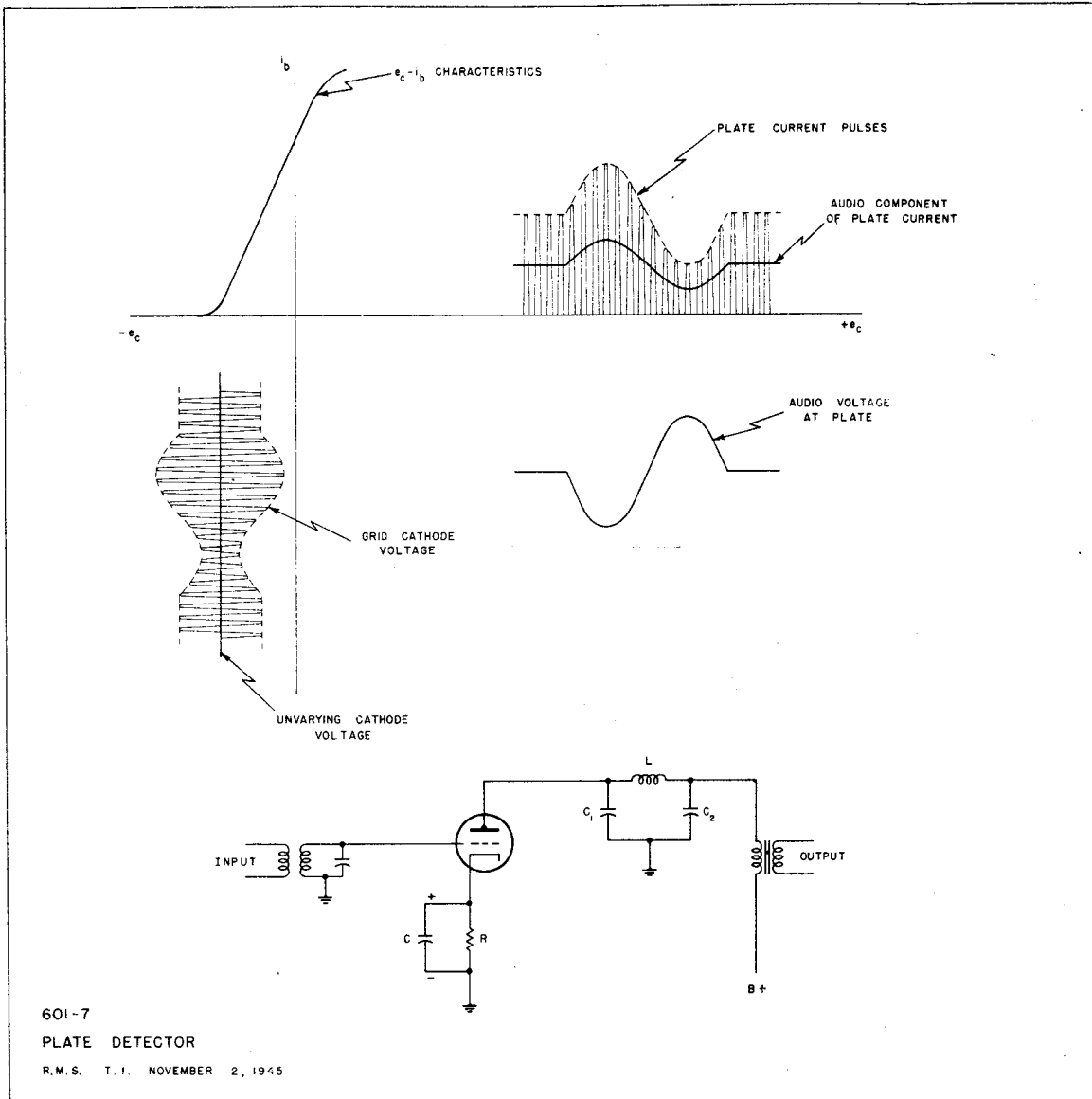

## PLATE DETECTOR

1. **SENSITIVITY:** Fair. Some amplification, but not as much as in the grid leak detector.
2. **SELECTIVITY:** Good. Very little loading of the tuned circuit.
3. **FIDELITY:** Fair. Not as good as the diode, but considerably better than the grid leak detector.
4. **NORMAL SIGNAL STRENGTH:** Medium. Signal should be strong enough so that the region of operation is not confined to the lower bend of the grid voltage plate current characteristic, but not so strong as to exceed the grid bias on modulation peaks.

**OPERATION:**

The plate detector employs a sharp cutoff tube which is biased nearly to cut off. A sharp cutoff tube is essential in order to avoid excessive distortion, resulting from detection on the lower curved portion of the grid voltage plate current characteristic. Bias is ordinarily obtained from the use of a large cathode resistor, which is bypassed for the lowest modulation frequency to be handled by the system. A modulated RF signal applied to the grid will then produce pulses of plate current which are approximately half sine waves. The tube is cut off during the negative half cycles of the RF grid voltage. The average values of these RF pulses increase and decrease as the magnitude of the RF envelope increases and decreases under modulation. The averaging of these RF pulses produces the audio voltage in the load. The RF components of the plate current are filtered out by the action of L, C1 and C2.

**LIMITATIONS:**

The values of signal strength which can be handled by this detector without objectionable distortion are severely limited. If the signal strength is weak detection will take place on the lower curved section of the grid voltage plate current characteristic. This produces a large amount of distortion. Even strong signals with a high index of modulation are distorted from this cause, as operation on the trough of the modulation cycle will be over the lower bend of the characteristic curve. Very strong signals will drive the grid into the positive grid region on the peaks of the modulation cycle. This also results in severe distortion. Satisfactory operation will be obtained with signals of medium strength and with modulation indices of eight tenths or less. If the signal strength is low enough so that the grid is never swung positive, the power drawn from the tuned circuit will be negligible and the selectivity will not be adversely affected.

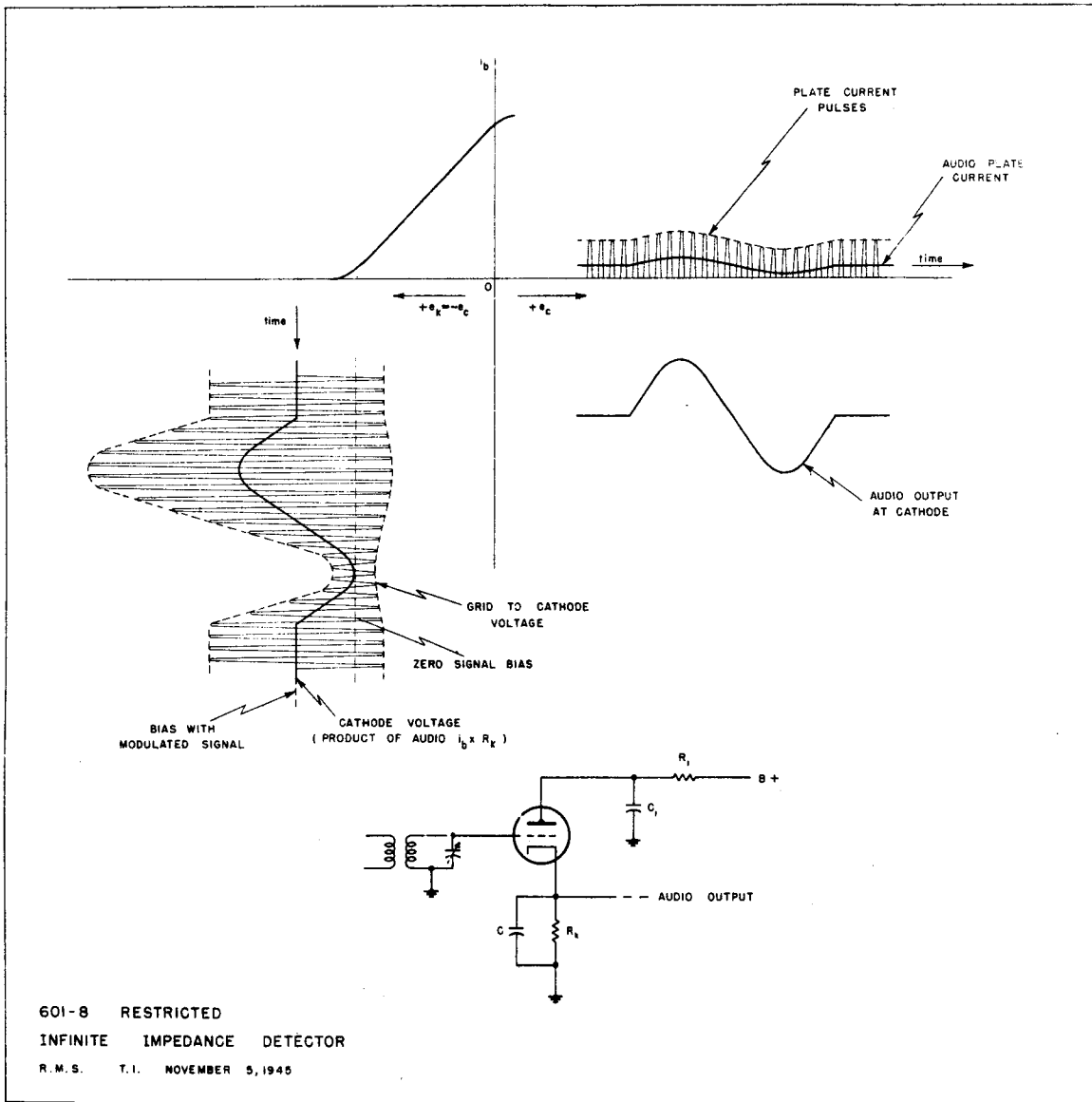

### INFINITE IMPEDANCE DETECTOR

1. **SENSITIVITY:** Poor. No amplification. About the same as for the diode.
2. **SELECTIVITY:** Good. No grid current flow for signal voltages up to a peak to peak value almost equal to the DC supply voltage.
3. **FIDELITY:** Excellent. A proper choice of R and C permits full modulation without peak clipping.
4. **NORMAL SIGNAL STRENGTH:** Strong. The signal amplitude that can be handled is limited only by the plate supply voltage available.

**OPERATION:**

The infinite impedance detector consists of a sharp cutoff tube biased close to cut-off by a very large cathode resistor. The cathode resistor is bypassed for the radio frequency but not for the audio frequencies. A modulated RF signal applied to the grid will cause pulses of plate current to flow on each positive grid swing. The tube is non-conducting on the negative grid swings. The rectified plate current increases the bias voltage developed in the cathode circuit, moving the operating point of the tube back as the amplitude of the modulation envelope increases. Since the cathode resistance is very large, a relatively small change in average plate current will produce a large variation in cathode voltage. The result of these factors is to limit the grid swings to the lower portion of the tube's grid voltage plate current characteristic, and to produce an audio output voltage in the cathode circuit which is practically equal in amplitude to the envelope of the modulated RF signal on the grid. If the amplitude of the RF voltage applied to the grid of the detector is kept large the effect of the curvature of the grid voltage plate current characteristic at the point of operation may be made small in comparison to the amplitude of the audio voltage produced and the distortion produced in the stage will be small. The plate and cathode of this detector are both at RF ground. The impedance presented by the tube to the driving circuit under this condition is the sum of the grid to plate and the grid to cathode capacities. The tube is then a reactive or non-dissipative load on the signal source. The same statement may be made for the plate detector. An advantage of the infinite impedance detector is that large signal swings may be handled before grid current flows.

**LIMITATIONS:**

Weak signals will be somewhat distorted as the curvature of the grid voltage plate current characteristic is appreciable at the low static currents employed in this type of detector. As the signal strength is increased the effect of this non-linearity becomes smaller, and at large signal strengths the distortion is very small. One of the main disadvantages of the infinite impedance detector is the fact that AVC voltage is not obtainable. Improper choice of constants for the cathode circuit will result in diagonal and negative peak clipping, but a proper choice of values with regard to the static DC plate current will allow the infinite impedance detector to follow the modulation envelope for any modulation index up to nine-tenths.

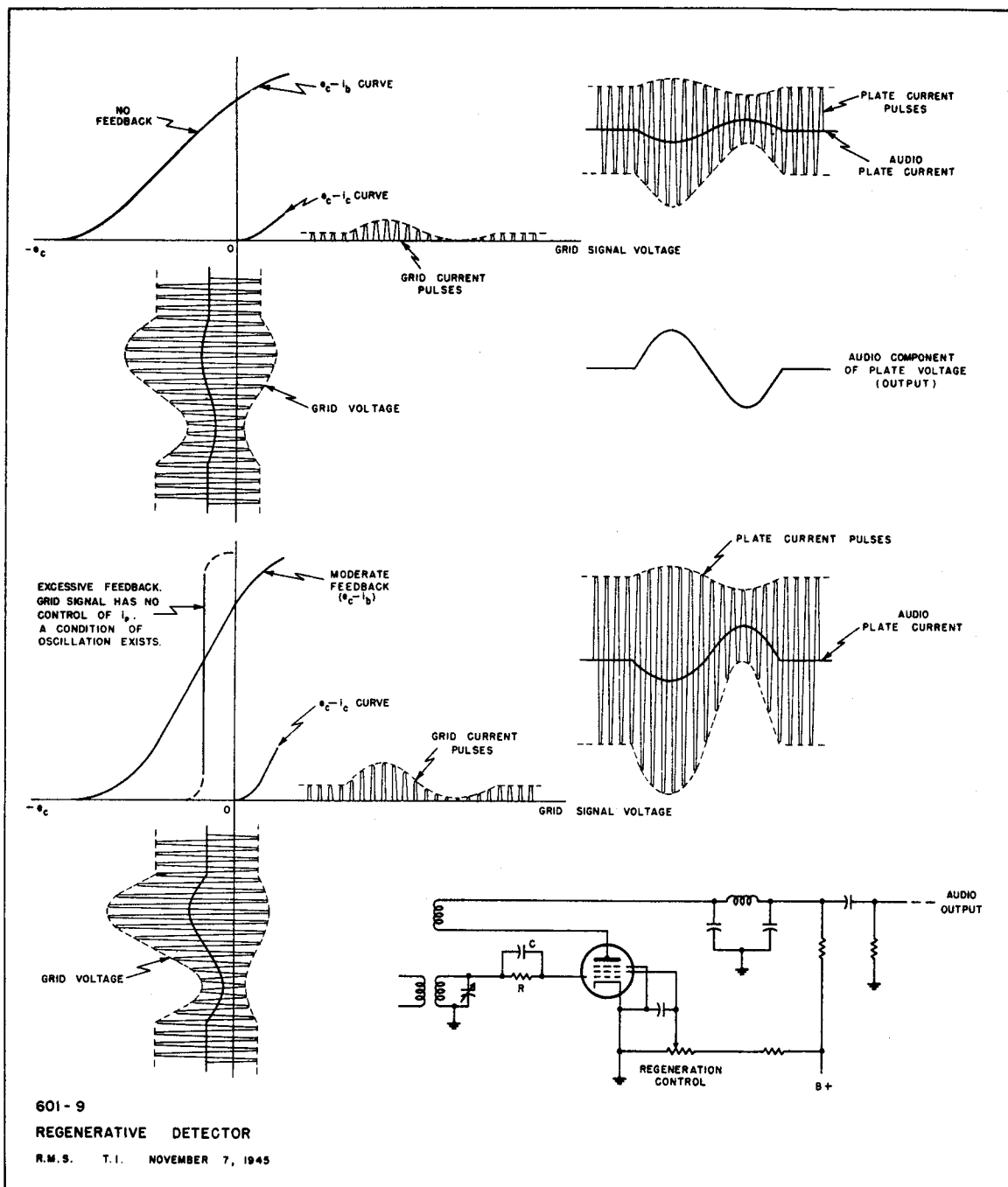

### REGENERATIVE DETECTOR

1. **SENSITIVITY:** Excellent. Largely due to effects of regeneration.
2. **SELECTIVITY:** Excellent. Largely due to the effects of regeneration.
3. **FIDELITY:** Very poor.
4. **NORMAL SIGNAL STRENGTH:** Weak.



The isoperiodic grid leak detector in which a portion of the plate circuit is fed back to the grid circuit in such a phase as to reinforce the original signal voltage variation. When amplitude is to be received, the amount of regenerative feedback is kept just below the point where sustained oscillations do not occur. One way of representing the circuit is to consider the grid signal voltage as the unvarying input voltage. As done, the effect of the feedback voltage to the grid is shown as a change in the plate current for a given grid signal voltage. The result is an increase in the slope of the grid voltage plate current characteristic. An increase in the slope of the grid voltage plate current characteristic back to the point where oscillations occur, is represented by a change in the transfer characteristic. That is, the grid signal voltage no longer varies linearly with the plate current. The effect of the feedback voltage is also shown as a decrease in the slope of the grid voltage grid current characteristic. The effect of feedback is then seen as an increase in amplitude of the signal in the grid circuit and as an increase in the amplification of that signal in the plate circuit. The conditions of no feedback, moderate feedback and over feedback are illustrated in Fig. 601-9. Regeneration greatly increases the selectivity of the detector.

The effect of increasing the "Q" of the tuned input circuit by increasing the apparent resistance of this circuit. That is, the greater the "Q" the more the resistance of the input circuit will be reduced and the selectivity will be increased. This produces an increase in the amplitude of the signal in the grid circuit which in turn is amplified thru the tube, increasing the selectivity. This build up effect continues until the natural resistance of the circuit prevents further increase. However, with too much regeneration the effective resistance may be controlled by the amount of amplification thru the tube or the feedback voltage to the input circuit, the effective resistance may be increased or decreased. This produces a regenerative effect resulting in sustained oscillations. The regenerative detector will have high selectivity and sensitivity due to the improved "Q" of the input circuit produced by feedback.

The regenerative detector is used for the reception of continuous wave telegraph signals. The detector is adjusted until sustained oscillations are produced. The audio frequency signal and the local generated oscillations is detected and amplified. Interruption of the C.W. signals by keying will result in the interruption of the audio output allowing an intelligent interpretation of the signals.

# RECEIVERS

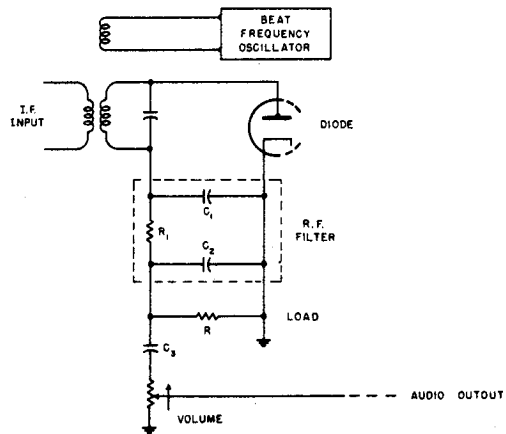
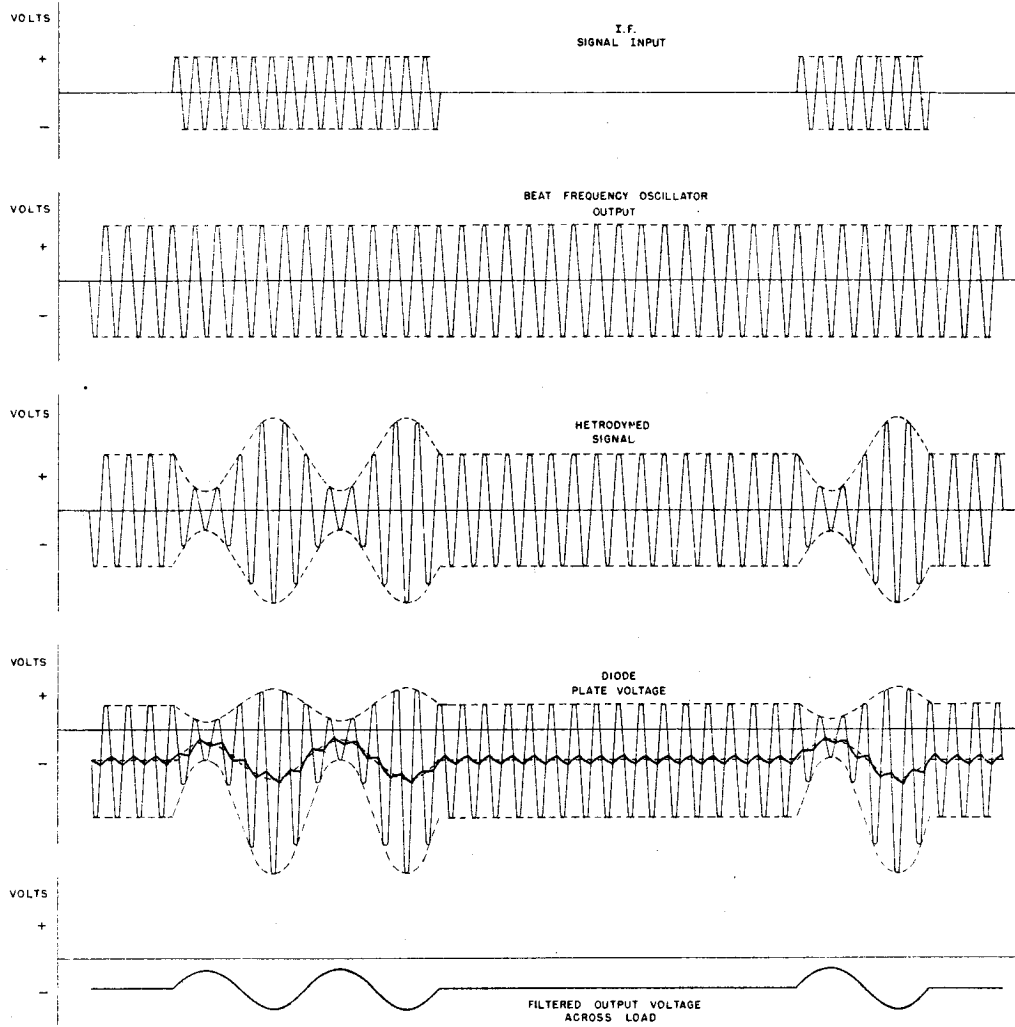

Essentially the same classes of non-linear devices are used for frequency conversion and detection of amplitude modulated waves. In each process the waves to be combined or resolved are applied to circuit elements which have non-linear voltage current characteristics. These circuit elements may simply be rectifiers such as a diode or copper oxide rectifier, or they may be multi-element tubes operated on a curved portion of the characteristic curve. The output circuit of a modulator is arranged to transmit the carrier and its side bands. The output circuit of a frequency converter passes the difference frequency (IF) and its side bands. The output circuit of a detector is designed to respond to current components at the frequency of the original signal. In each case the current components at frequencies other than those desired are eliminated by filtering in the output circuit.

HETERODYNE DETECTION is a means of detecting modulated or unmodulated signals by mixing the incoming signal with a locally generated signal and then applying the resultant to a non-linear impedance.

In Fig. 601-10 the two original signals, one of which is periodically interrupted, are shown added together point by point. This composite wave is then applied to a detector. The current components at the RF and at the modulation or beat frequency can readily be distinguished in the diode plate voltage diagram. The undesired RF variations are eliminated by filtering and only the audio voltage variation, which occurs at the difference frequency between the two original signals, is present in the output.

# RECEIVERS

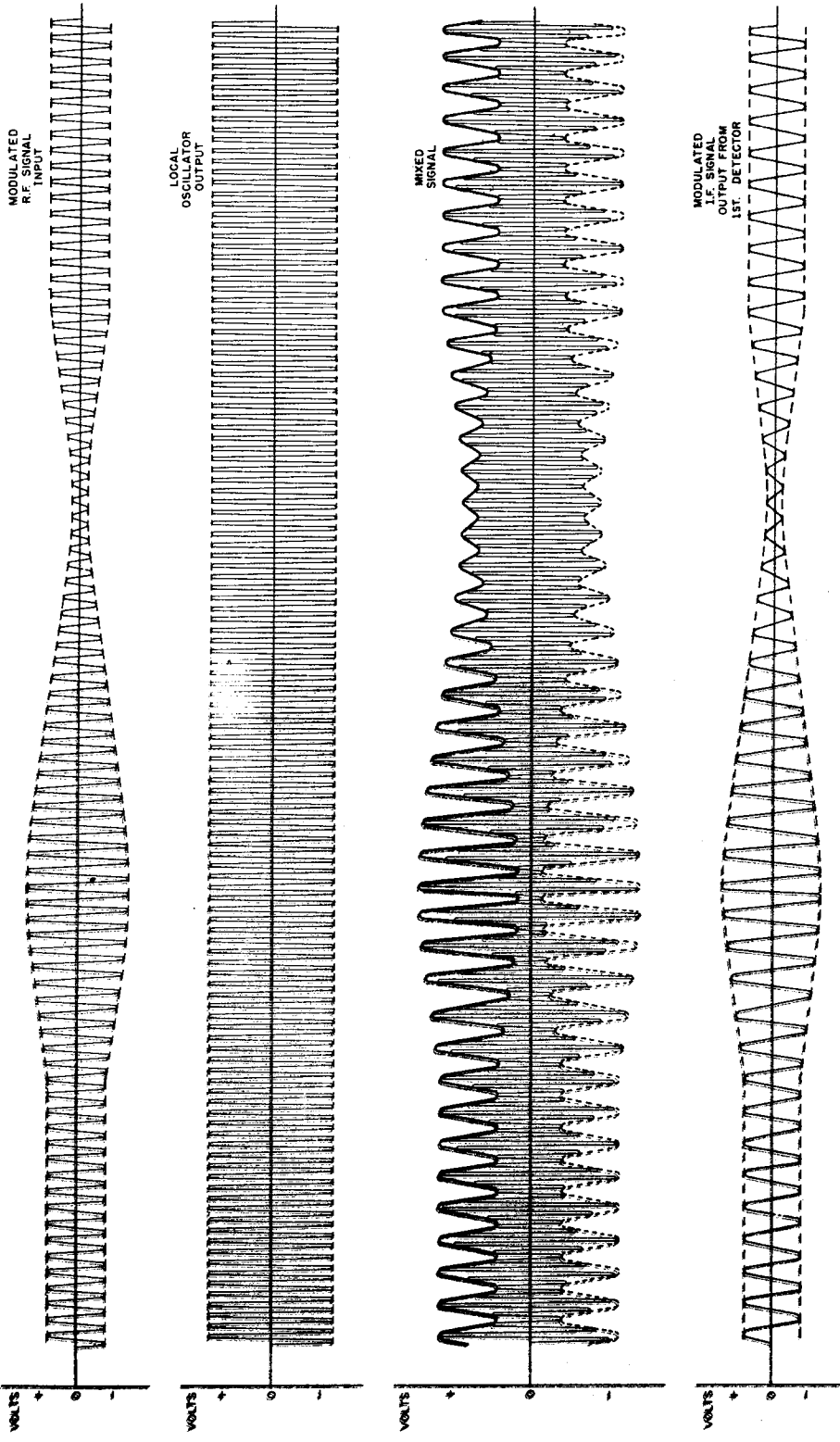

60-11 RESTRICTED  
MIXER ACTION  
R.M.S. T.I. NOV. 2, 1945

The first detector employs the principle of heterodyne action to convert the frequency of the incoming signal to the intermediate frequency. The Modulation of the incoming signal is retained as an identical modulation of the intermediate frequency wave.

The manner in which this is accomplished is illustrated in Fig. 601-11. The original incoming modulated wave is shown first. Below it is shown the output of the local oscillator. These two signals are added point by point and the resultant signal shows the beat frequency between the two original signals, modulated in amplitude in the same manner as the modulation envelope of the original incoming signal. Detection, and filtering in the plate circuit, will produce this amplitude modulated beat frequency in the output as shown in the last line of the Figure. A second detection applied to this wave will recover the original modulating frequencies.

The functions performed by the first detector are:

1. To mix the incoming signal and the locally generated oscillation.
2. To detect the resultant combined signal.
3. To separate the desired modulated intermediate frequency component from the undesired signal components.

A first detector in which the local oscillator is a separate tube is called a MIXER. The name CONVERTER is applied to a circuit in which one tube performs the functions of both oscillator and detector.

RECEIVERS

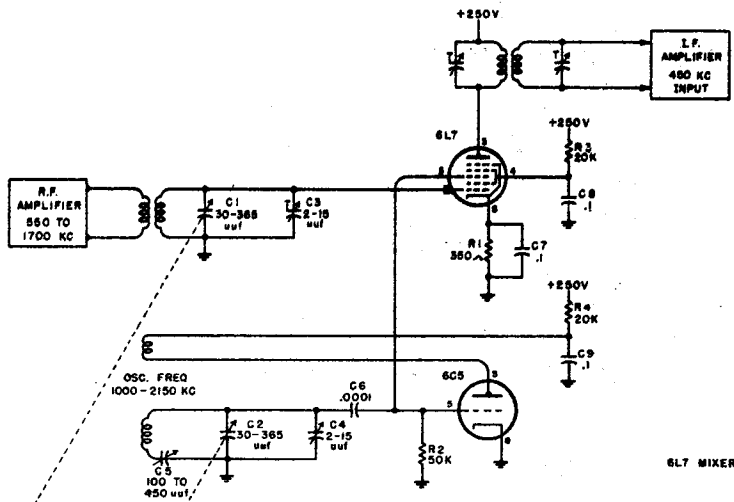

6L7 MIXER

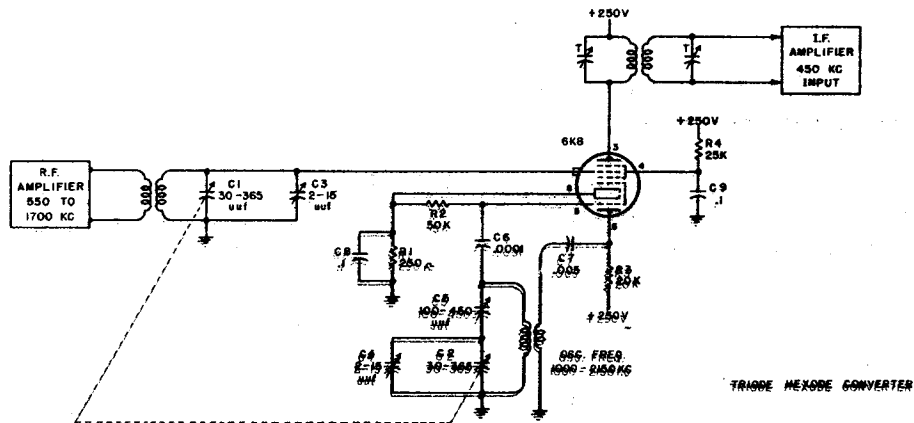

TRIODE HEXODE CONVERTER

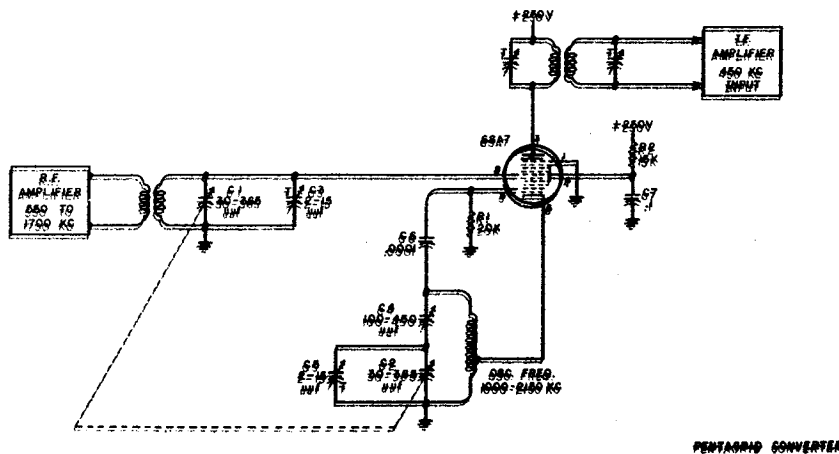

PENTAGRID CONVERTER

**THE 6L7 MIXER:**

Referring to Fig. 601-12, the 6C5 is an Armstrong oscillator. The local oscillator signal, present on the grid of the 6C5, causes grid current to flow, producing grid leak bias which is also present on grid #3 of the 6L7. The local oscillator signal is injected on grid #3 of the mixer tube, and the incoming signal is applied to grid #1 of the mixer. Mixing takes place in the 6L7 due to the double modulation of the electron stream by the incoming signal and the local oscillator signal. The bias developed across the cathode resistor is sufficient to prevent the incoming signal from overdriving grid #1. The total bias for the tube holds the 6L7 at projected cutoff, and the combined signal is detected in the plate circuit. The difference frequency which is the desired modulated IF signal is separated from the other signal components by the tuned transformer in the plate circuit.

**THE 6K8 TRIODE HEXODE CONVERTER:**

The triode section is a shunt fed Armstrong oscillator. The oscillator signal and the bias on the oscillator grid will also be present on grid #1 of the hexode mixer section, because of the internal connection to the oscillator grid. The incoming signal is introduced on grid #3 of the hexode mixer section. Mixing takes place due to the double modulation of the electron stream by the incoming signal and the local oscillator signal. The total bias places the tube operating point at projected cutoff, and the mixed signals are detected. Separation of the IF signal from the other signal components takes place in the plate circuit.

**THE 6SA7 PENTAGRID CONVERTER:**

Grid #2 is the anode of a grounded anode Hartley oscillator. Grid #1 is the oscillator grid. The incoming signal is applied to grid #3. Mixing is due to the double modulation of the electron stream by the incoming signal and the oscillator signal. The total bias is sufficient to place the operating point at or beyond cutoff and detection results. On the positive swing of the oscillator tank voltage, grid #1 is driven positive causing the tube to conduct. The cathode is connected to a tap on the oscillator tank, and is driven slightly positive by the same positive swing of the oscillator tank voltage. While the tube is conducting, the positive voltage on the cathode supplies bias for grid #3, preventing the signal voltage from causing grid current to flow. Separation of the IF signal from the other signal components takes place in the plate circuit.

## OSCILLATOR TRACKING

Most modern superhetrodyne receivers are tuned by means of a single control. This requires special provisions to be made to obtain proper tracking. That is, a constant frequency difference (IF) between the local oscillator and the RF circuits must be maintained as the tuning control is varied.

Perfect tracking is illustrated in Fig. 601-13. Here an example of a typical broadcast receiver is illustrated. The exact frequency difference can not be obtained for all positions of the tuning control. This is illustrated by the dotted curve of Fig. 601-13 below.

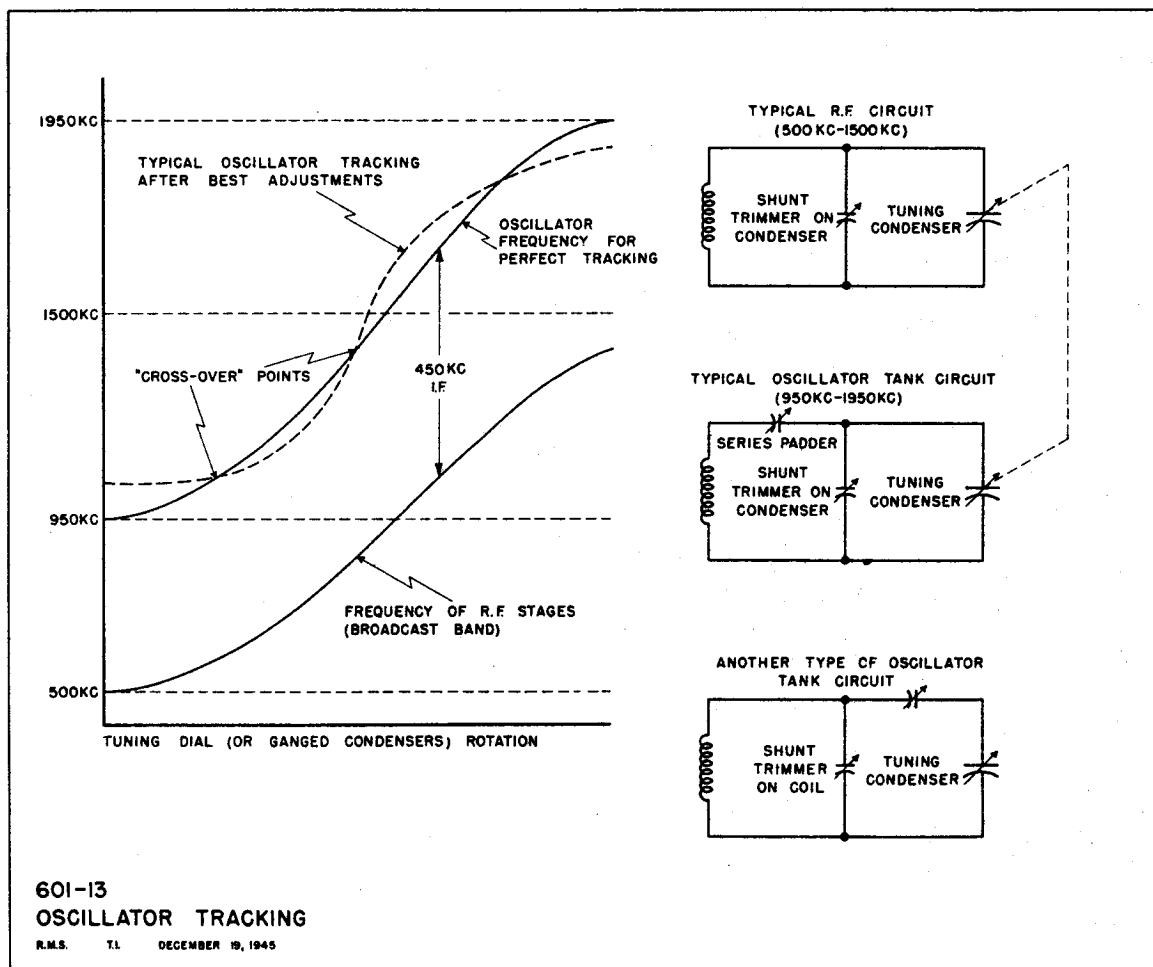

The components used as tuning elements vary with different receivers depending on the IF chosen and whether the local oscillator frequency is made above or below the carrier frequency. For example, in most broadcast sets and short wave receivers the local oscillator frequency is chosen above the carrier frequency. This permits the use of a reasonable size tuning capacitor and coil design. As can be seen from the curves of Fig. 601-13 the frequency ratio between maximum and minimum values is



different for the RF range and the local oscillator range. This means that the capacity change from maximum to minimum will be different for the two circuits. To obtain the proper over-all capacity range in the local oscillator circuit, using a normal size tuning capacitor, a 'padder' is added in series with the main tuning capacitor. Then in addition small capacitors called 'trimmers', in parallel with the RF and local oscillator main tuning capacitors are used to improve the tracking between the two circuits. Trimmers and padders are illustrated in Fig. 601-13.

Hence a padder in series with the tuning capacitor and a trimmer shunted across the tuning capacitor are both needed to assure proper tracking of the oscillator circuit. Shunt trimmers are needed to assure tracking of the RF circuits. The oscillator and RF trimmers are adjusted at the high frequency end of the band for proper alignment. The oscillator padder is adjusted at the low frequency end of the band.

As can be seen from the curves in Fig. 601-13 it is not possible to get perfect tracking over the entire band. The amount of imperfection is dependent to a large extent upon proper coil design. However, with proper design and adjustment of trimmers and padders it is usually possible to obtain the proper IF at three different points in the band. Tracking in a single band receiver may sometimes be improved by bending the end plates of the RF tuning capacitor.

Adjusting of multi-band receivers is similar to that of a single band receiver. Usually in multi-band receivers each RF and local oscillator coil will have individual trimmers or padders, making it possible to adjust each band separately.

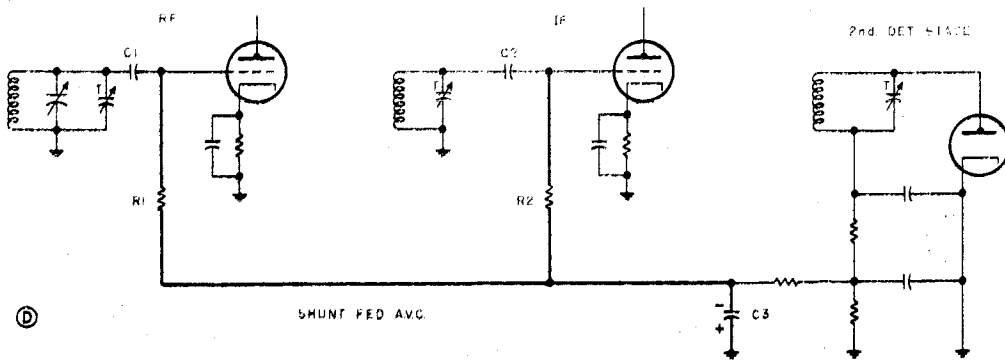
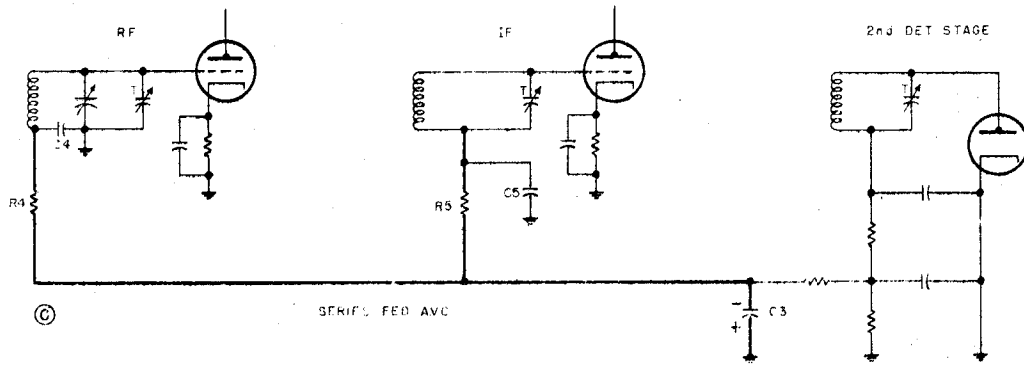
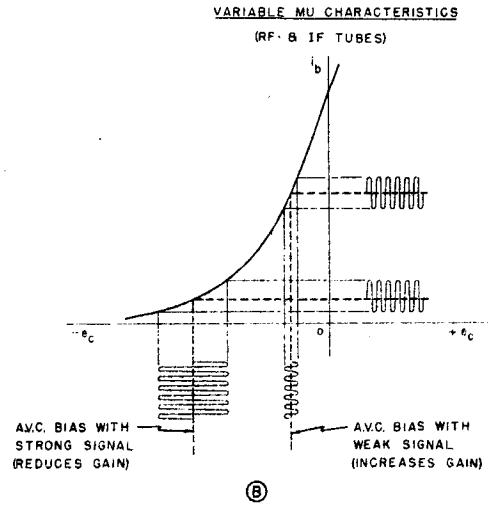
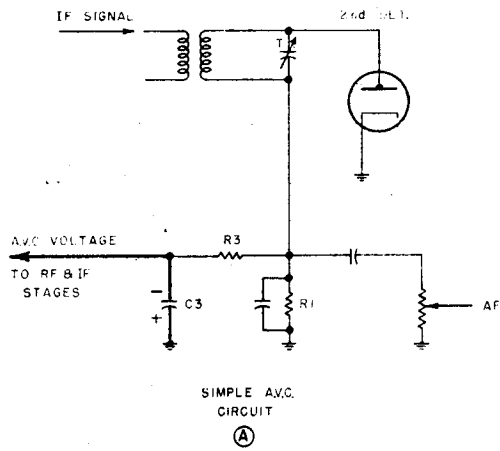

Automatic volume control is used to compensate for variations in signal strength such as are caused by fading. It is accomplished by automatically varying the bias of the RF and IF amplifiers in such a way as to compensate for the variations in signal strength.

The diode detector in Figure 601-14A is an example of one method of obtaining AVC bias voltage. A detected signal produces a voltage drop across  $R_1$  which is varying at audio frequencies but whose average makes the top of  $R_1$  negative with respect to ground. The audio filter  $R_3C_3$  prevents the AVC voltage from varying at audio frequency. Hence  $C_3$  charges to the average value of the negative voltage across  $R_1$ .  $C_3$  can charge and discharge at a slow rate to follow ordinary fading but will not vary its charge with the relatively fast variations of the modulated carrier. The time constant  $R_3C_3$  determines the speed with which the AVC voltage responds. This is often made faster for high frequency receivers than for ordinary broadcast sets where good fidelity is more important. In all cases an increase in carrier strength results in more negative AVC bias and a decreased carrier strength produces a less negative AVC bias.

The AVC bias is applied to RF and IF amplifiers which use variable-mu tubes. As shown in Fig. 601-14B weaker signals are amplified to a greater degree than are stronger signals due to the tube characteristics.

The simple AVC system shown in Fig. 601-14A has the following disadvantages:

- (a) AVC reduces the receiver sensitivity.
- (b) "Between stations" or with no incoming signal considerable back-ground noise will be heard.
- (c) The AVC coupling network causes distortion (negative peak clipping) of the audio output from the detector.
- (d) A diode is the only type of second detector that can be used.

It is possible to eliminate the last two disadvantages by using a separate diode to provide AVC voltage.

Two methods of AVC feed, series and shunt, are shown in Fig. 601-14. In Fig. C,  $R_4C_4$  and  $R_5C_5$  form decoupling networks. In Fig. D,  $R_1$  and  $R_2$  prevent an RF short to ground for the tuned circuits, and the condensers act as DC blocking capacitors for the AVC voltage.

The use of full AVC in the last IF stage of a high gain receiver and in the first detector is not recommended, though sometimes used. The application of full AVC to the first detector causes oscillator frequency instability and using AVC on last IF stage of a high gain receiver results in distortion. Partial or fractional AVC reduces these troubles. By using part of the voltage developed across  $R_1$  (in Fig. 601-14A) fractional AVC can be obtained.

The sensitivity of receivers which employ a beat frequency oscillator for the reception of ICW signals is reduced by AVC action because of the large AVC bias built up by the BFO signal. Also the intelligence of ICW signals may become distorted by AVC action. Most receivers of this type are provided with a means of removing the AVC during the reception of ICW signals.

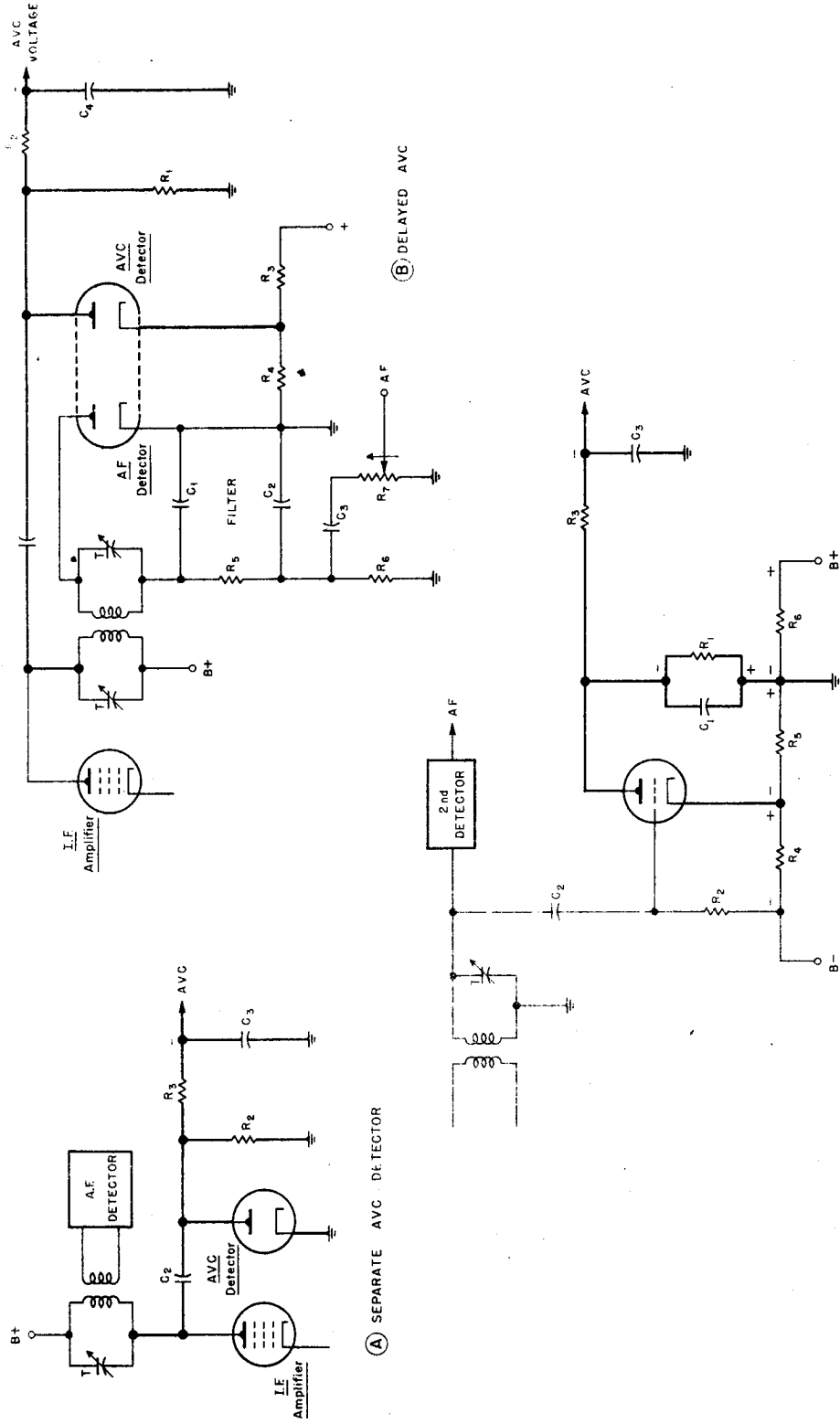

Fig. 601-15A illustrates the use of a separate diode as an AVC detector which has the advantage of reducing distortion in the audio signals due to AVC action. In this circuit the capacitor C charges during the positive half of the IF signals through the diode. During the negative half of each cycle C discharges through the resistor R. This produces a negative voltage across R that varies at the audio frequency variations of the IF modulated signals.  $R_3$  and  $C_3$  form an audio filter with a time constant that results in  $C_3$  charging to a DC voltage which is the average of the audio voltage across R. This is used for AVC bias.

Because of reduced receiver sensitivity due to AVC bias action it is sometimes desirable to prevent its action during weak signals but still have it function to reduce the gain for strong signals. Delayed AVC is used in this type of design. With DAVC the manual receiver gain can be set at maximum value for weak signals and the AVC will not function. However, when the carrier voltage reaches a certain strength sufficient to overcome the "delay" voltage on the AVC detector the AVC begins to function to reduce the receiver gain. Fig. 601-15B illustrates this type of circuit. The positive bias voltage in the cathode circuit of the second diode section is known as the delay voltage. The diode is cut off until a signal strength which is greater than this delay voltage exists. When this signal voltage is great enough the diode functions as in any other AVC circuit.

Amplification of the AVC bias voltage will result in improved AVC action. As shown in Fig. 601-15C, a plate detector is used to produce an AVC bias voltage. A plate detector circuit may be used to an advantage as an AVC detector due to its inherent amplification characteristics. The AVC detector plate is grounded through  $R_1$ . The cathode is negative with respect to ground. The grid is more negative than the cathode and sufficient to cut off the tube. This bias beyond cut-off causes a delaying action for the AVC. The IF signal is coupled to the AVC detector through C. A signal strong enough to overcome the negative bias on the grid will cause the plate detector to conduct and will produce a negative voltage across  $R_1$ .  $R_3$  and  $C_3$  form the audio filter and  $C_3$  charges up to the average negative voltage across  $R_1$ . This charge on  $C_3$  is used as the AVC bias voltage.

RECEIVERS  
GENERAL NOTES

## RECEIVERS - GENERAL REVIEW

The receivers covered in this course are communication type, for receiving CW, MCW and PHONE signals. Waveforms of these three types of signals are shown in Fig. 16.

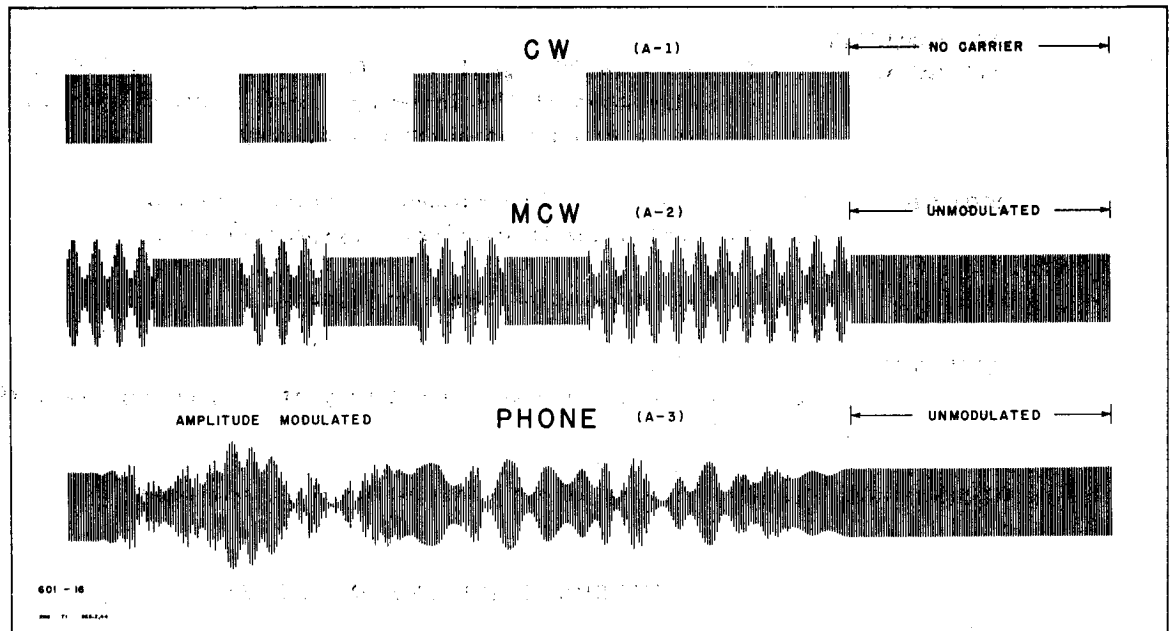

Fig. 16 Waveforms of three types of emission.

## RECEIVER CHARACTERISTICS

1. **SENSITIVITY:** Ability of receiver to pick up weak signals and deliver a useable output.
  - (a) Determined by signal-to-noise ratio.
  - (b) 10 microvolts is the minimum sensitivity for Navy receivers.
    - (1) Standard sensitivity is determined by internal noise only.
    - (2) Overall sensitivity is determined also by external noises and by the width of the receiver band-pass.
2. **SELECTIVITY:** Ability of receiver to discriminate against undesired signals.
  - (a) Exceptionally good selectivity required in communication receivers.
3. **FIDELITY:** Ability of receiver to reproduce incoming signal without distortion.
  - (a) Fidelity is sacrificed in communication receivers to improve the sensitivity and selectivity.
4. **STURDINESS:** Ability of receiver to withstand shock and to give reliable service under difficult operating conditions.
  - (a) Sturdiness is essential in military receivers.

# COMPARISON OF TRF AND SUPERHETERODYNE

## TUNED RADIO FREQUENCY RECEIVER

- RF STAGES:**
1. Amplify the desired signal. (Pentode tubes).
  2. Amplification should be linear. (Class A operation).
  3. Reject undesired signals. (Tuned circuits).
- BEAT FREQUENCY OSCILLATOR:**
1. Produces an RF signal at a frequency about 1,000 cycles above or below that of the incoming signal. Mixes with the incoming signal to produce an audible frequency.
- DETECTOR:**
1. Removes the audio component. (Demodulation).
  2. Eliminates the RF carrier. (By-pass filter).
- AF STAGES:**
1. Amplify the audio frequency signal.
- ADVANTAGES:**
1. Simplicity.
  2. Good sensitivity and selectivity at frequencies lower than about 800 kcs.
- DISADVANTAGE:**
1. Sensitivity is not constant over any one band.

## SUPERHETERODYNE RECEIVER

- RF STAGES:**
1. Same as in TRF.
- LOCAL OSC.:**
1. Generates a sine wave which when mixed with the incoming signal will produce a difference frequency which is the receiver intermediate frequency.
- 1st DETECTOR: (MIXER)**
1. Produces the IF by mixing the incoming RF signal and the local oscillator signal.
- IF STAGES:**
1. Amplify the IF signal. (Pentode tubes).
  2. Amplification should be linear. (Class A operation).
  3. Reject undesired signals. (Fixed tuned circuits).
- BFO:**
1. Produces a signal at a frequency about 1,000 cycles above or below the IF which mixes with the IF to produce an audible frequency.
- 2nd DETECTOR:**
1. Same as detector in TRF.
- AF STAGES:**
1. Same as in TRF.
- ADVANTAGES:**
1. Better sensitivity and selectivity over entire frequency range.
  2. Constant sensitivity and selectivity over the entire frequency range.
- DISADVANTAGE:**
1. Image response.



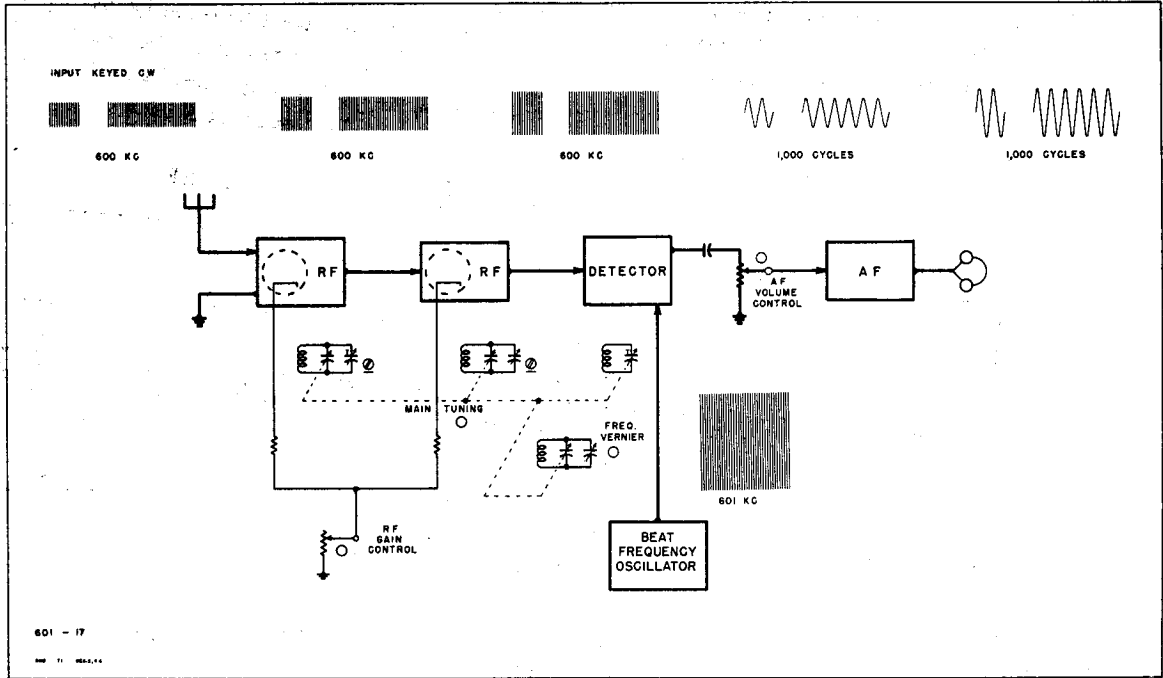

Fig. 17 TRF block diagram.

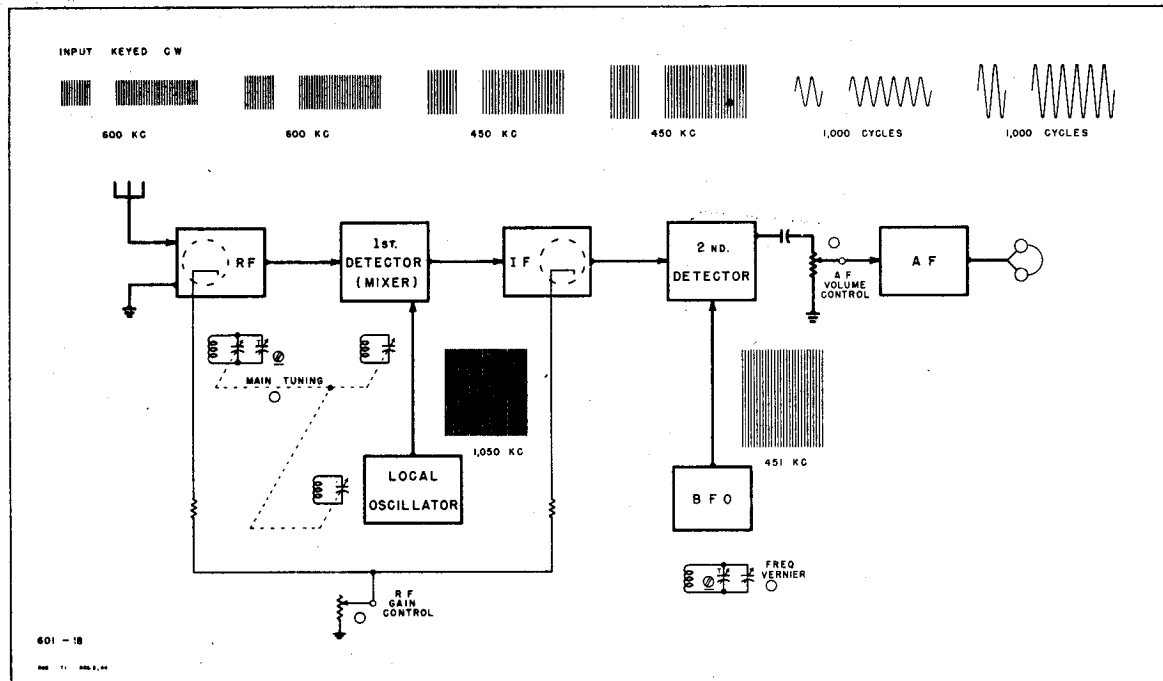

Fig. 18 Superheterodyne block diagram.

## RECEIVER ALIGNMENT

**PURPOSE:** To cause all tuned circuits to operate simultaneously at corresponding frequencies. Alignment is NOT a trouble-shooting procedure. Never try to align a receiver unless it definitely needs aligning. Follow any special alignment procedure given in the manufacturer's instruction book for each receiver.

### ALIGNING TRF, GENERAL PROCEDURE

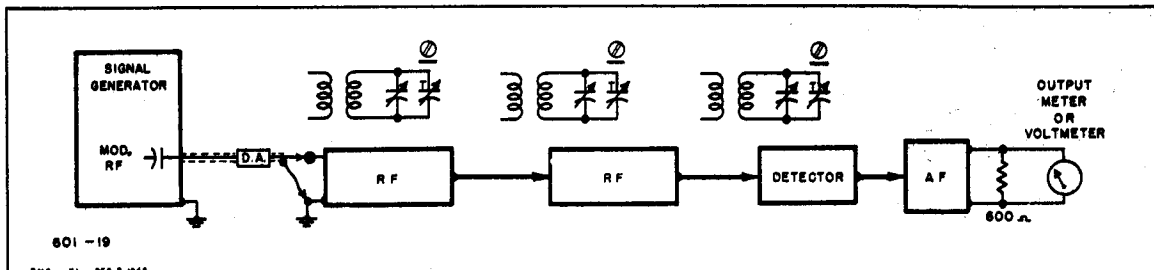

Fig. 19 Aligning TRF

1. Connect the equipment as in Fig. 19.
2. Turn off all special circuits (noise limiter, output limiter, etc.)
3. Set the receiver gain control at maximum.
4. Tune the receiver to a frequency near the high end of the band.
5. Set the signal generator to the same frequency reading as the receiver.
6. Adjust sig. gen. attenuator control until output meter reads about  $\frac{1}{2}$  scale.
7. Adjust the trimmers in all RF stages and in the DETECTOR for maximum output. Reduce input signal as necessary to keep output meter reading on the scale.

### ALIGNING SUPERHET, GENERAL PROCEDURE

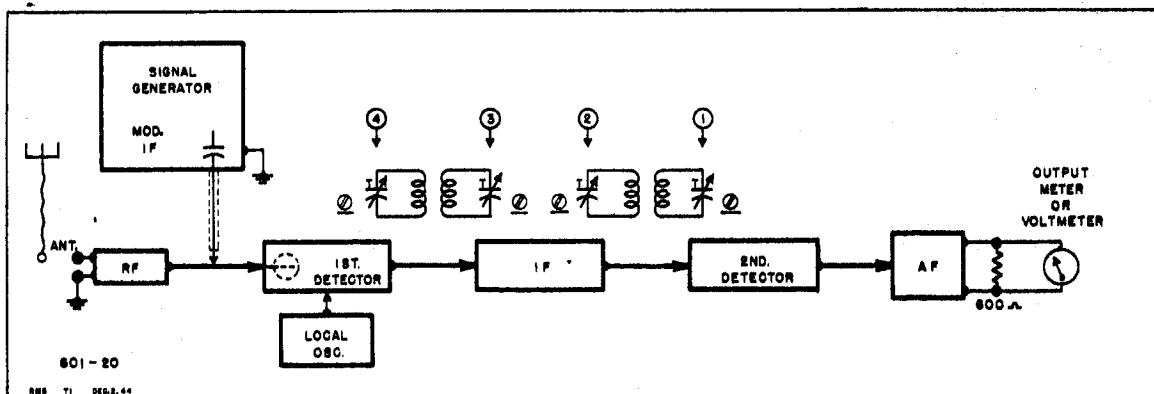

Fig. 20 Aligning IF transformers.

1. Connect the equipment as in Fig. 20.
2. Turn off all special circuits (AVC, noise limiter, output limiter, etc.).
3. Set the receiver gain control at maximum.
4. Set the signal generator to the receiver IF. (See instruction book).
5. Adjust sig. gen. attenuator control until output meter reads about  $\frac{1}{2}$  scale.
6. Adjust the IF trimmers for maximum output, in the order shown in Fig. 20. Reduce input signal as necessary to keep output meter reading on the scale.

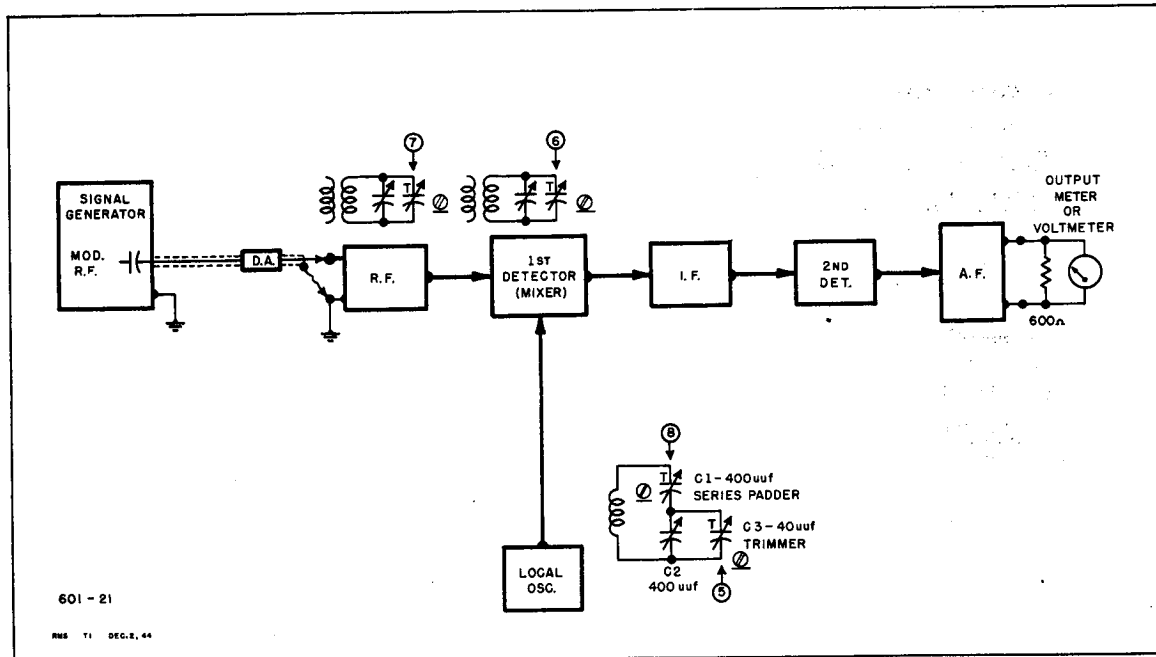

Fig. 21 Aligning tuner unit.

7. Connect the equipment as in Fig. 12.
8. Tune the receiver to a frequency near the high end of the dial.
9. Set the signal generator to the same frequency reading as the receiver.
10. Adjust sig. gen. attenuator control until output meter reads about 1/2 scale.
11. Adjust trimmers (5), (6) and (7) for maximum output.
12. Set the receiver dial to a frequency near the low end of the band.
13. Repeat steps 9 and 10.
14. Adjust the series padder (8) for maximum output.
15. Repeat steps 8, 9, and 10.
16. Adjust trimmer (5) for maximum output.

VISUAL ALIGNMENT

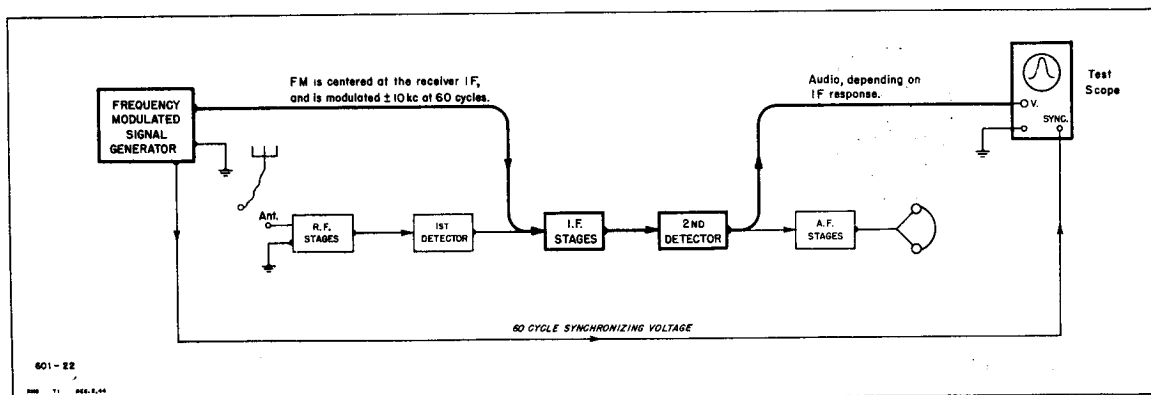
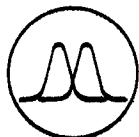
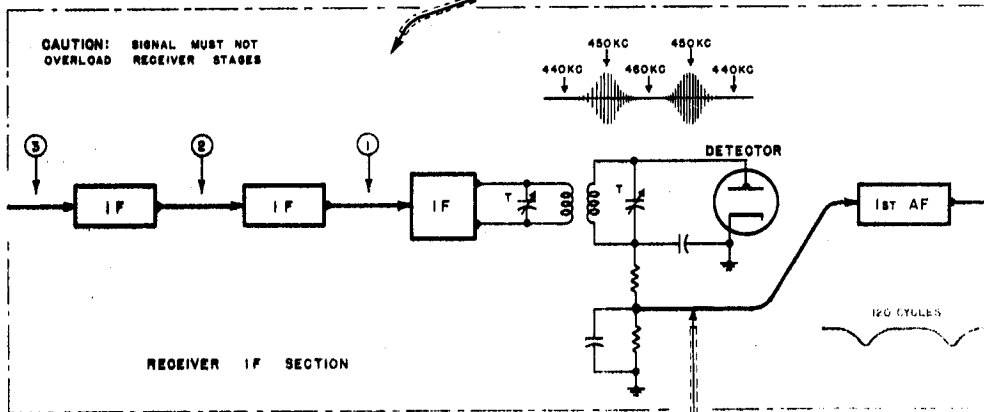
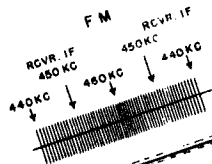
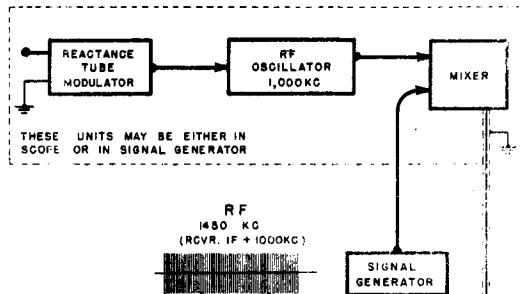
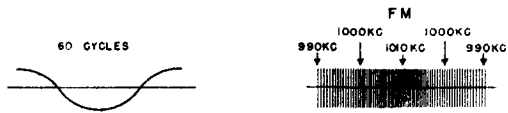
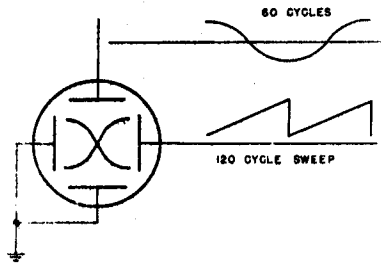

Fig. 22 Typical ho kup f r visual alignment.

# VISUAL ALIGNMENT

## PRELIMINARY STEPS

1. MAKE RECEIVER LOCAL OSCILLATOR INOPERATIVE
2. APPLY 60 CYCLE SIGNAL TO SCOPE VDP (BY PLACING FINGER ON VDP CONNECTION); ADJUST SWEEP VERNER AND SYNCHRONIZING CONTROLS FOR CROSSOVER AT CENTER OF SCREEN AS SHOWN BELOW.



INCORRECT ALIGNMENT



REGENERATION DUE TO CAUSES OTHER THAN MISALIGNMENT, BUT SHOULD BE ELIMINATED.

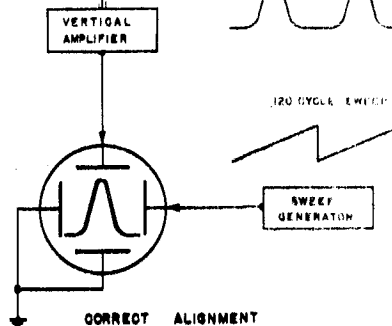

CORRECT ALIGNMENT ADJUST TRIMMERS UNTIL BOTH TRACES GOING SIDE AND ARE MAXIMUM HEIGHT.

Fig. 23 Visual alignment.

## SENSITIVITY MEASUREMENTS

**PURPOSE:** To compare the receiver sensitivity with a normal rating. Sensitivity is rated as the minimum number of microvolts of signal input capable of causing a desired value of signal output. The rating differs with various equipments, and in each case it is necessary to consult the instruction book. For example, test conditions for a typical Navy receiver, the Model RHB, are:

## 1. SET NOISE REFERENCE LEVEL.

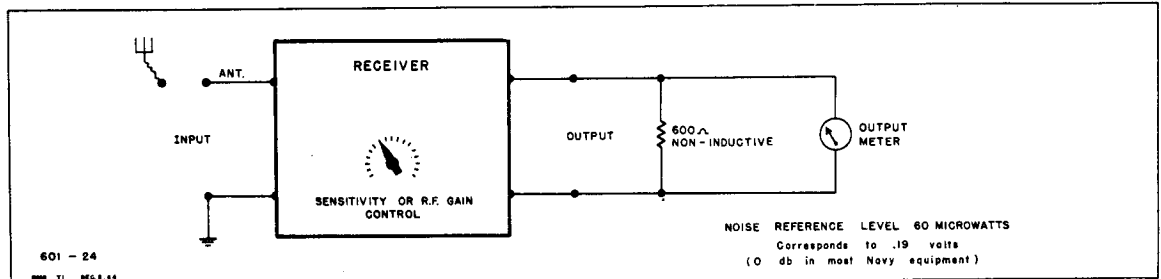

Fig. 24 Hookup for setting noise reference level.

- Disconnect the antenna from the receiver antenna post.
- Turn off all special circuits (noise limiter, output limiter, silencer).
- Adjust the sensitivity (RF gain) control so the receiver noise level is equivalent to 60 microwatts on the output meter. If the internal noise is less than 60 microwatts, set the RF gain at maximum.

## 2. MAKE SENSITIVITY MEASUREMENT.

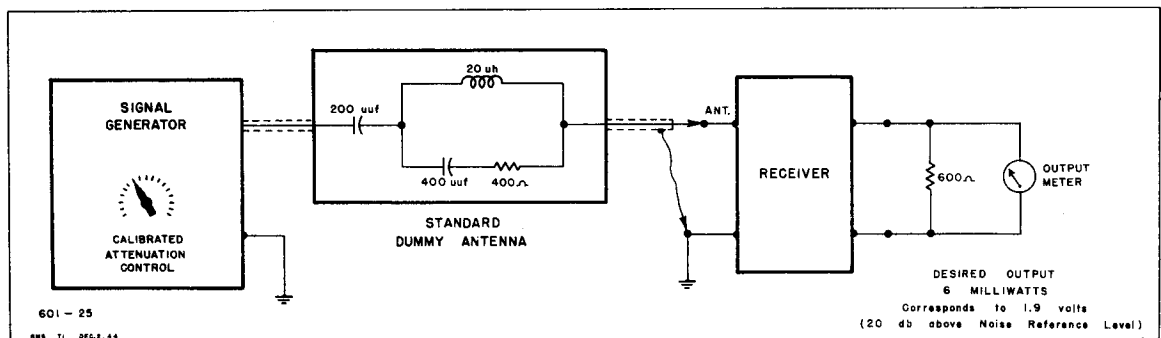

Fig. 25 Hookup for making sensitivity measurement.

- Without changing the setting of the receiver sensitivity control, connect the equipment as in Fig. 25. If no standard dummy antenna is available, substitute a 200 uF capacitor instead.
- Adjust the receiver and the signal generator to the specified frequency, and modulate the RF signal 30% at 1000 cycles.
- Adjust the signal generator attenuator control until the receiver output is equivalent to 6 milliwatts on the output meter.
- The reading of the signal generator attenuator control (which is calibrated in microvolts) is the sensitivity of the receiver.

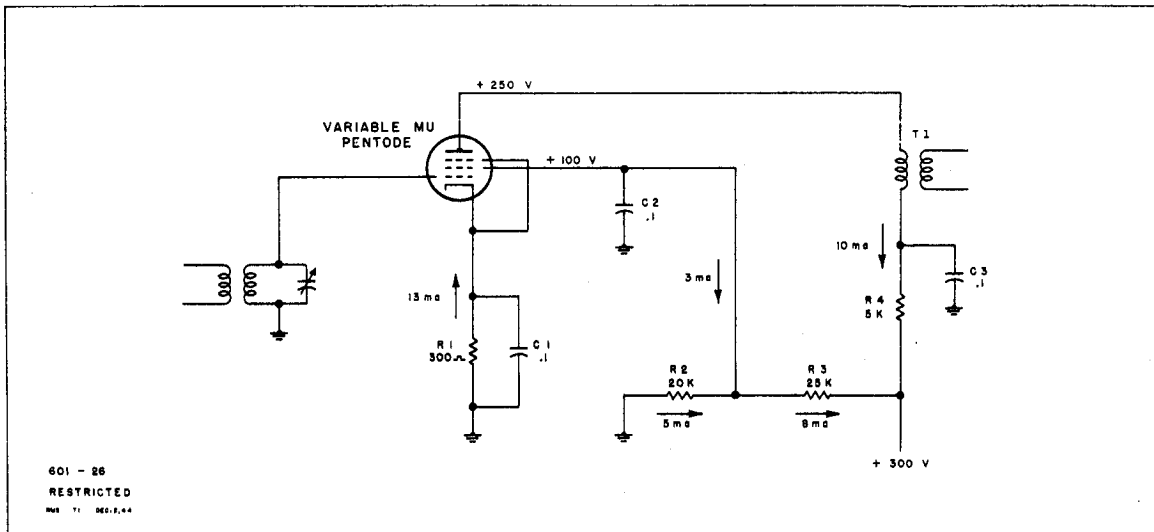

Fig. 26 Typical RF amplifier.

#### STATIC CONDITIONS (NO INCOMING SIGNAL)

1. **PLATE CIRCUIT:** 10 ma of plate current flowing through the 5,000-ohm decoupling resistor R-4 causes a 50-volt drop which subtracts from the 300-volt supply, leaving 250 volts on the plate with respect to ground.
2. **SCREEN GRID CIRCUIT:**
  - (a) Bleeder resistor R-2 is 20,000 ohms and passes 5 ma of current.
  - (b) Screen dropping resistor R-3 is 25,000 ohms and passes a total current of 8 ma (5 ma bleeder current and 3 ma screen current), causing a drop of 200 volts, leaving 100 volts on the screen.
3. **CATHODE CIRCUIT:** The cathode (or minimum bias) resistor R-1 is 300 ohms. The total tube current of 13 ma through R-1 causes a drop of 3.9 volts, which is bias between the control grid and cathode. (The grid is at DC ground).

#### TROUBLE SHOOTING ANALYSIS

1. **PLATE CIRCUIT:**
  - (a) If either R-4 or the primary of T-1 opens:
    - (1) Plate voltage and plate current both will be zero.
    - (2) Screen current will increase slightly.
    - (3) No voltage drop across R-4.
    - (4) Less total tube current causes less voltage drop across R-1.
    - (5) The gain of the stage will be zero. Signals may be transferred through the stage due to tube capacity.
  - (b) If C-3 shorts:
    - (1) Plate voltage and plate current both will be zero.
    - (2) The voltage drop across R-4 will increase to the total B+ voltage, and current flow through R-4 will increase.

- (3) Screen current will increase slightly.
- (4) Less total tube current causes less voltage drop across R-1.
- (5) The gain of the stage will be zero.

## 2. SCREEN GRID CIRCUIT:

- (a) If R-3 opens:
  - (1) Screen voltage, screen current, and the voltage drop across R-2 and R-3 all will be zero.
  - (2) Plate current and total tube current through R-1 will decrease. Plate voltage will increase.
  - (3) The gain of the stage will decrease.
- (b) If C-2 shorts:
  - (1) Screen voltage, screen current, and the drop across R-2 all will be zero.
  - (2) The drop across R-3 will be the total  $E^+$  voltage.
  - (3) Plate current and total tube current through R-1 will decrease. Plate voltage will increase.
  - (4) The gain of the stage will decrease.
- (c) If R-2 opens:
  - (1) Current flow through R-3 will decrease and the voltage drop across R-3 will decrease.
  - (2) Screen voltage and screen current both will increase.

## 3. CATHODE CIRCUIT:

- (a) If R-1 opens:
  - (1) Tube current will cease.
  - (2) Plate voltage will be 300 volts.
  - (3) Screen voltage will be less than 300 volts by the drop across R-3 due to bleeder current continuing to flow.
  - (4) The gain of the stage will be zero.
- (b) If C-1 shorts:
  - (1) Bias on the tube will be zero.
  - (2) Plate and screen currents will increase.
  - (3) Plate and screen voltages will decrease.
  - (4) The control grid will draw current, causing distortion which will be more noticeable on strong signals than on weak ones.
- (c) If C-1 opens:
  - (1) The cathode voltage across R-1 will swing with changes in the incoming signal, because changes in plate current which previously flowed through the low reactance path provided by C-1 now flow through R-1.
  - (2) This causes degeneration because the cathode swings positive at the same time the control grid swings positive resulting in decreased output from this stage.

# RECEIVER SERVICING

## VISUAL CHECKS

1. **PURPOSE:** To isolate the source of trouble to a defective stage.
2. **PROCEDURE:**
  - (a) Obtain information on the trouble symptoms. Ask the operator some questions. For example: Is the receiver dead, or how does it act? Did the trouble develop suddenly or gradually? Was the receiver smoking, smelling hot, or showing other obvious signs of trouble? **IF ANY INDICATION SUGGESTS A SHORT OR EXCESSIVE CURRENT DRAIN ON THE POWER SUPPLY, LEAVE POWER OFF AND TAKE RESISTANCE MEASUREMENTS.**
  - (b) Operate the receiver yourself. See if all meters, indicators, and controls are operating normally and are properly adjusted.
  - (c) Check all external connections (antenna, ground, power, plugs, etc.).
  - (d) Remove the chassis and look for obvious troubles (broken tubes, loose or broken leads, burnt or charred resistors, leaking wax, mechanical defects, faulty insulation, etc.).

## SIGNAL INJECTION

1. **PURPOSE:** To isolate the defective stage, if visual checks fail.

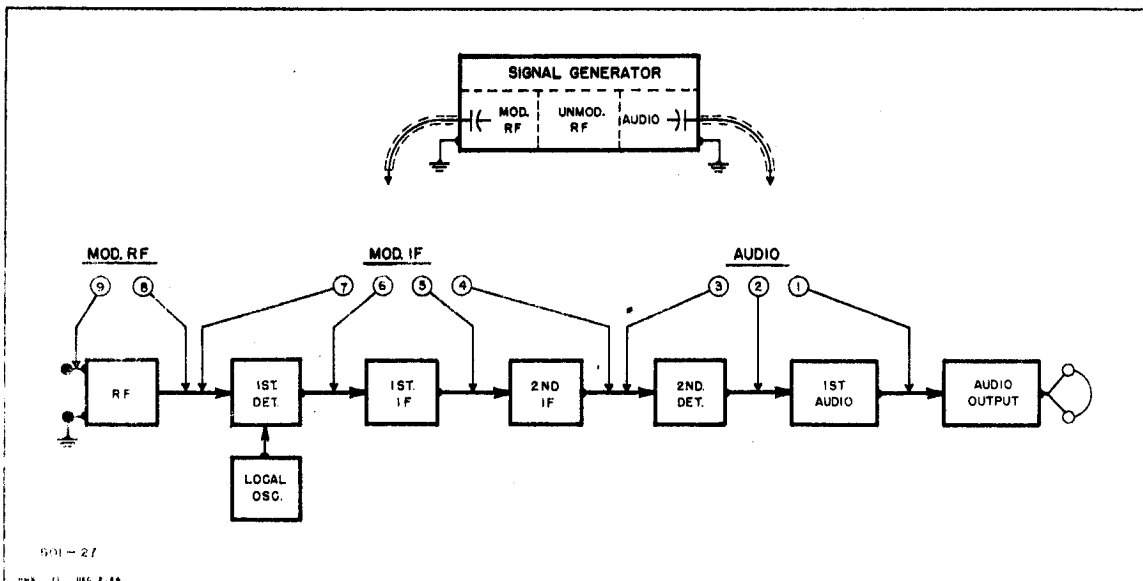

Fig. 27 Signal injection.

2. **PROCEDURE:**
  - (a) Be sure there is a ground connection between the receiver and the signal generator.
  - (b) Apply signal to test points in the order shown, being sure that the signal applied at any point is of proper frequency, and of amplitude comparable to normal signal at that point. Too strong a signal may be forced through dead or defective stages.



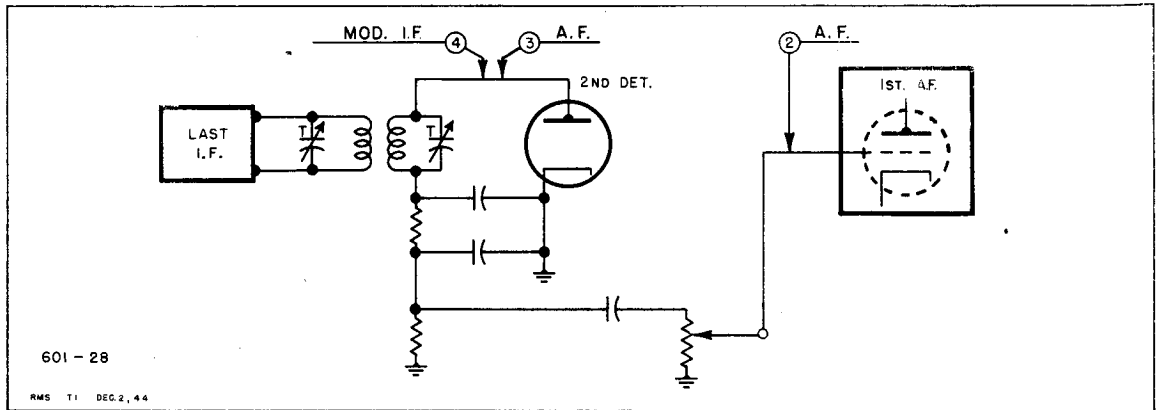

Fig. 28 Signal injection in 2nd detector.

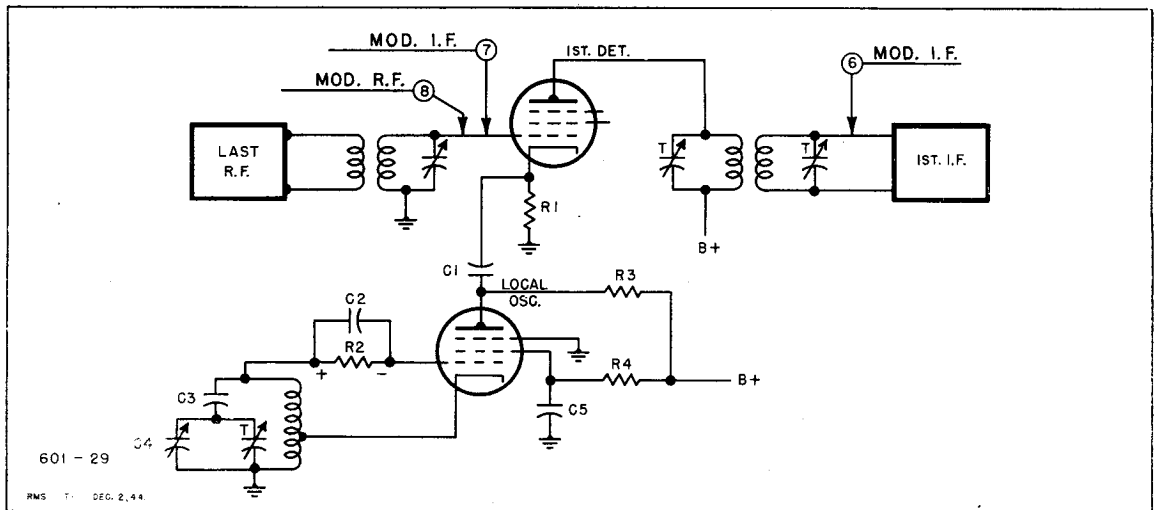

Fig. 29 Signal injection in 1st detector and local oscillator.

VOLTAGE AND RESISTANCE MEASUREMENTS

1. PURPOSE: To find the faulty PART in a defective stage.
  - (a) To be used only after isolating the defective unit or stage.
  - (b) REMOVE ALL POWER before taking resistance measurements.
  - (c) Compare readings with those previously taken when the equipment was OK, or with those in the instruction book (not with tube manual data).
    - (1) Allow for the shunting effect of the meter unless using the same type as listed in the instruction book.
    - (2) Normal tolerance of most readings is  $\pm 20\%$ , even when the line voltage is correct.
  - (d) Use the wiring diagram as well as the schematic in taking point-to-point continuity checks.

# RECEIVER SERVICING

## INSTRUCTION BOOKS

Two instruction books should accompany each equipment. If not packed with the equipment, the instruction books may be mailed to the Commanding Officer. Ask for them through the Communications Officer. Study the instruction books and the equipment. Learn all the important points, and know where to find additional details. While the equipment is in good operating condition, take readings with the ship's own test equipment and compare with those listed in the instruction books. Record all discrepancies, and make additional tests if necessary to obtain complete test data for future trouble shooting. From the instruction books and the actual installation, make your own functional block diagrams, simplified schematics, etc., so all technicians in the crew can thoroughly understand the equipment and especially the installation aboard ship.

## UPKEEP ROUTINE

Establish and follow a detailed routine, carefully prepared to fit each unit of equipment, from basic requirements determined by:

- (a) BuShips Manual (Manual of Engineering Instructions), Chapter 31.
- (b) Manufacturer's maintenance specifications.
- (c) Individual installation. Provide for any special care made necessary

by unusual exposure to weather or shock, limitations of space, poor ventilation; weaknesses discovered in actual use or from equipment history, service bulletins, et cetera.

Record in an appropriate log or equipment history file all inspections, unusual performance, casualties, replacement of parts, adjustments, and any other data of possible future reference value. Following is a skeleton outline of the very minimum general inspections and tests to be made and logged:

(a) **DAILY.** Test all idle receiving equipment for operation. Make a visual check of the antenna system for obvious defects.

(b) **WEEKLY.** Check frequency meters for accuracy against Bureau of Standards transmissions as per current instructions from Bu Ships. Check all access door safety devices.

(c) **MONTHLY.** Install a complete set of tested vacuum tubes in one half of all receiving equipment. Test replaced tubes and retain satisfactory ones for future use. Check radio direction finder calibration curves on at least 5 points and at least 3 frequencies, using transmissions from stations on visible or accurately known bearings. Measure receiver noise level in each band as per current instructions from BuShips. Lubricate all sliding mechanical contacts with vaseline or non-fluid mineral oil. Follow the manufacturer's recommendations for lubricating all rotating machinery.

(d) **QUARTERLY.** Make sensitivity measurements of all receivers as per current instructions of BuShips. Record in the Receiver Log all results of tests before and after any corrective action. Check the operation of volume limiter, audio tuning, and all other special controls. Infrequently used switches and controls may oxidize enough to fail, especially in weak signal circuits. Check the

# RECEIVER MAINTENANCE

calibration of each receiver for the frequency in use, or for which the receiver is standing by. Check inventory of tubes and spare parts, and requisition the necessary parts to fill the allowance for each equipment.

(e) **ALTERATIONS.** Permission from your Commanding Officer must be obtained before making any alterations to either the inside or outside of any equipment.

(f) **SPARE PARTS BOXES.** Those furnished with each equipment contain only parts that are most likely to fail. Complete or "tender" spares are furnished with each 4, 10, or 20 equipments, and usually are kept on a tender or at a supply base. Keep spare parts boxes filled to full quota -- an empty or depleted spare parts box may mean a Court Martial for the technician. When any part is removed, order a replacement immediately. List all parts removed, and leave the list in the top of the box until all parts are replaced.

## SUPPLY WORK

**COMMUNICATION EQUIPMENT INDEX.** A record of each unit of equipment must be kept on file in the appropriate station aboard. The required data is shown on the sample form in Fig. 30. A new book form of equipment log is being issued by BuShips, but if the log book is not available cards similar to this sample may be obtained from the nearest Radio Materiel Officer (RMO) or Navy Yard.

Typical form,  
half size.

Model <i>RBB-1</i>	Name of Equipment <i>RADIO RECEIVER AND RECTIFIER POWER UNIT</i>	Serial No. <i>738</i>	Custody Card No. <i>145</i>
<b>COMMUNICATION EQUIPMENT INDEX (RESTRICTED)</b>		U.S.S. <i>RMS, T.I.</i>	
<small>THE COMMUNICATION EQUIPMENT INDEX AND EQUIPMENT HISTORY MUST BE TRANSFERRED WITH THE EQUIPMENT.</small>			
Contractor <i>RCA MFG. CO., INC.</i>		Contract No. <i>91265</i>	
Date of acceptance by I.N.M. <i>8-25-43</i>		Date placed in service <i>6-26-44</i>	
Guaranteed for: <i>2</i> years from acceptance;		<i>1</i> Years of service	
Installed by <i>Joe Blank, RT 1/2</i>		at <i>RMS, T.I.</i>	
Installation supervised by (Ship's Representative) <i>R. B. Jones Lt(jg)</i>		Approved by (Ship's Head of Dept. or Comm'n. Officer) <i>A. R. Smith Lieut</i>	
Name Plate Data of Assemblage and Component Parts. (Give location. Use additional blank cards as necessary.)			
<i>RADIO RECEIVER</i> TYPE <i>CRV 46147</i> FREQ. RANGE <i>0.5 TO 4 MC.</i>  INPUT <i>6.3V-60W, 17V-60W, 105V-DC, 200V-DC</i> <i>5.0 A. .6 A. .005A. .078A.</i>  WT. <i>82 POUNDS</i>		<i>RECTIFIER POWER UNIT</i> TYPE <i>CRV 20130</i> SERIAL <i>156</i>  INPUT <i>110/115/120V-60W, 100 WATTS</i>  OUTPUT <i>6.3V-60W, 17V-60W, 105V-DC, 200V-DC</i> <i>5. A. .6A. .005A. .078A.</i>  WT. <i>52 POUNDS</i>	

Front

Typical form,  
half size.

<small>P.S.N.Y. 8-21-44 15M</small>		<b>Spare Parts Boxes</b>
Box No.	General Contents	Location
<i>1</i>	<i>RESISTORS AND CAPACITORS</i>	<i>STOREROOM C-401-A</i>
<i>2</i>	<i>TUBES AND TRANSFORMERS</i>	<i>STOREROOM C-406-A</i>
Index of Correspondence, Bulletin of Engineering Information Articles, Circular Letters, etc., pertaining to this equipment:— <i>COMMUNICATION EQUIPMENT MAINTENANCE BULLETIN, FILE C, ISSUE 4</i>		

Back

Fig. 30 Typical Communication Equipment Index Card.

# RECEIVER SERVICING

**EQUIPMENT HISTORY:** This is a continuation of the equipment index record, and may be kept conveniently on cards like the sample in Fig. 31, on blank cards, or in the equipment log book. The complete index and history record must accompany the equipment when it is transferred. The history should include a record of the original installation, normal readings, maintenance routine, repairs, adjustments, tests, inspections, and especially peculiarities of value to other technicians.

EQUIPMENT <b>RBB-1</b> SER. 738		SUMMARY OF PART CONCERNED <b>IF-AF UNIT, 3RD IF STAGE</b>		DATE <b>27 Nov. 1944</b> U. S. S. <b>RMS, T.I.</b>
P.A.N.Y. 4-31-44 11M COMMUNICATION EQUIPMENT HISTORY REPORT No. <b>5</b>				
Casualty, Defect, or Symptoms of Trouble: <b>RECEIVER SMOKING - NO OUTPUT</b>				
Work Done: <b>C-335 FOUND SHORTED, CAUSING R-319 TO BURN OUT. REPLACED BOTH FROM SPARES. RECEIVER SENSITIVITY FOUND POOR ON ALL BANDS. REPLACED WEAK TUBE V-302 AND PEAKED UP ALIGNMENT ADJUSTMENTS IN IF CHANNEL. SENSITIVITY MEASURES OK.</b>				
References:				
Check Form(s) Available - Insert Serial No. and Date Submitted	PERSONNEL ON JOB (NAME AND RATE)		MAN HOURS	IN CHARGE AT JOB
✓ Form N 808 888 11-27-44	<b>John Doe, RTc</b>		4	<b>C.E. Bloom</b> CRT RTc
✓ S & A Form 308 43 11-27-44				<b>R.T.B.</b>

Typical form, half size.

Fig. 31 Typical Communication Equipment History Card.

**GUARANTEES:** Receiver vacuum tubes are usually guaranteed by their individual manufacturers for from 90 days to 1 year, whether in storage or in actual service. Some are guaranteed for a certain number of hours of actual service. Receiving equipment other than tubes is usually guaranteed for 1 year of service within 2 years after acceptance by the Inspector of Naval Materiel, or for 2 years of service within 5 years after acceptance. Guarantees may expire before the equipment is installed.

**PARTS FAILURE:** The new simplified failure report card shown in Fig. 32 is to be filled out and mailed to BuShips according to the instructions on the back of the card for every failure of parts other than tubes, regardless of guarantees.

Front Official Forms NBS 383, about one-third size Back

<b>FAILURE REPORT—ELECTRONIC EQUIPMENT</b> NAME OF COMMAND OR STATION: <b>A.M.S. TREASURE ISLAND, CALIF.</b> NAME OF PERSON MAKING REPORT: <b>JOHN DOE, RTc</b> DATE: <b>10-15-45</b>		NOTICE: Read a line or section only. Add, delete, or change the contents of this report only in the margin. THIS REPORT IS TO BE FILED IN THE OFFICE OF THE INSPECTOR OF NAVAL MATERIEL, WASHINGTON, D. C.	
EQUIPMENT INVOLVED: <b>RBB-1</b> SERIAL NO. OF EQUIPMENT: <b>738</b> MANUFACTURER: <b>RCA MFG. CO.</b> DATE OF MANUFACTURE: <b>9-26-45</b>		ITEM WHICH FAILED: <b>RESISTOR R-319</b> PART NO. OF EQUIPMENT: <b>43360</b> DATE OF FAILURE: <b>6-26-44</b>	
THIS FAILURE OCCURRED: <input checked="" type="checkbox"/> WHILE IN USE <input type="checkbox"/> WHILE IN STORAGE <input type="checkbox"/> WHILE IN TRANSPORT			
CAUSE OF FAILURE: <b>R-319 FAILED BECAUSE OF OVERLOAD AFTER C-335 SHORTED.</b>			
LIFE OF EQUIPMENT: <b>LIFE 10 1/2 MONTHS, SAME FAILURE OCCURRED ONCE BEFORE ON 11-27-44.</b>			
(Do not delay submitting this form—insert in envelope—Post-Box)			
DISPOSITION OF MATERIAL: <b>ALL components of tubes found should be discarded as to use of tubes with operating Salvage and Security Base Station. (No more used for training or other purposes.) In the case of apparent failure of any component, the report action will be taken by the Bureau for collection and return of samples for an analysis.</b>		REMARKS (Continued)	

Fig. 32 New Official Parts Failure Reports, NBS 383. (Rev. 3-45)

**REQUISITION FOR REPLACEMENT PARTS.** Immediately after making a replacement from the spare parts box, requisition a duplicate part from the ship's Supply Officer. If the parts are carried in stock by the ship's supply department, they may be obtained immediately with a stub requisition, S and A Form 307 (See Fig. 35). If the parts are not carried by the ship, the technician must fill out S and A Form 303 shown in Fig. 33, or at least must furnish the Supply Officer with the equivalent technical information. From this, the Supply Officer makes out an official requisition. The surest way of getting the parts is for the technician to take the approved requisition personally to the nearest tender, supply pool, or Navy Yard, and bring the parts back with him. Otherwise the Supply Officer will send for them. Only enough parts to fill the ship's quota will be supplied for any one equipment. List parts for each equipment separately. Any part ordered for unofficial equipment will cause the entire requisition to be canceled. File in your Communication Equipment History a record of requisition similar to the sample shown in Fig. 34.

Official Form S and A 303, half size.

S. and A. Form 303 (Revised June 1943) MEMORANDUM REQUEST FOR REQUISITION AND STUB REQUISITION OR MEMORANDUM REQUEST FOR SURVEY

From: COMMUNICATIONS Dept. (or office). Date 27 Nov. 1944  
 To: Supply Officer. Stub No. \_\_\_\_\_

It is requested that a Requisition/Stub be prepared for the following article or services:

Standard Stock Catalog No. or Class No.	Quantity Required or to be Surveyed	Unit	DESCRIPTION IF REQUISITION—Give detailed specifications for each item and reason if requesting non-standard material. IF SURVEY—Give reason therefor, and Custody Card No. and location.	Value
<u>16-R-63360</u>	<u>1</u>	<u>No.</u>	<u>RESISTOR, FIXED, CARBON, 4700 OHMS ± 10% ½ WATT, INSULATED, TYPE BT½ ITEM No. 65, RCA DWG. PART No. K-850781-70, SCHEM. SYMBOL R-319</u>	

If for spare parts: Installation RBB-1 RADIO RECEIVER, SERIAL 738

Spare part box No. 1 Manufactured by: Name RCA MFG. CO., INC.  
 J. O. No. \_\_\_\_\_ Title D-K-F. Address CAMDEN, N. J.

Replacement is  desired.

Name plate data: HP \_\_\_\_\_ RPM \_\_\_\_\_ Serial No. \_\_\_\_\_  
 Mfg. type No. \_\_\_\_\_ Mfg. dwg. No. \_\_\_\_\_ Part No. \_\_\_\_\_  
 Voltage \_\_\_\_\_ AC-DC amps. \_\_\_\_\_ Mach. index No. \_\_\_\_\_

If Requisition: No. \_\_\_\_\_ dated \_\_\_\_\_ If Stub: Issued by A. K. Smith  
 If Survey: No. \_\_\_\_\_ dated \_\_\_\_\_ Received by \_\_\_\_\_

U. S. GOVERNMENT PRINTING OFFICE 16-1067

Fig. 33 Official Request for Requisition for replacement parts.

Typical form, half size.

(Tear off this part, except for tab, before filing.) INCOMPLETE REQUISITION

P.S.N.Y. 5-21-44 15M RECORD OF REQUISITION FOR COMMUNICATION MATERIAL (RESTRICTED) U. S. S. RMS, T. I.

Attach this form to related Equipment History Sheet. DATE 27 Nov. 1944  
 TAB to be removed only after this form is completed.

Requested Material is for use with:	Specifications and Ordering Information Obtained by:	Completed Forms Submitted to Supply Office	Material to be Ordered From:	Authority for Ordering:
<u>RBB-1 SER. 738</u>	<u>JOHN DOE, RT2</u>	By: <u>LT. A. K. SMITH</u> Date: <u>27 Nov. 1944</u>	Navy Yard at <u>MARE IS.</u> Direct from Factory _____ Open Purchase _____	<u>A. K. S.</u>

DESCRIPTION: (This Description should be a Carbon Copy of Description given on S. and A. Form No. 303.)

16-R-63360 1 No. RESISTOR, FIXED, CARBON, 4700 OHMS ± 10%  
½ WATT, INSULATED, TYPE BT½  
ITEM No. 65, RCA DWG. PART No.  
K-850781-70, SCHEM. SYMBOL R-319  
RBB-1 RADIO RECEIVER, SERIAL 738  
RCA MFG. CO., INC.  
CAMDEN, N. J.

RECEIVED ON BOARD AND INSPECTED			TITLE	Installed or stowed in:	Checked
By: _____	Date: _____	Condition: _____	B _____ C _____ F _____	By: _____ Date: _____	Approved _____

Fig. 34 Typical record of requisition.

## RECEIVER SERVICING

**VACUUM TUBE FAILURE:** Receiver and general purpose tubes costing less than \$5.00 may be replaced from spares without special report. Replacements should be requisitioned immediately from the ship's Supply Officer on S and A Form 303 (Fig. 33).

**WORK REQUESTS:** When radio or other equipment needs repair or servicing beyond the scope of the ship's own facilities, a work request signed by the head of the department and approved by the Commanding Officer must be submitted to the tender or Navy Yard. Unless the tender or yard furnishes blank forms, this work request may be in the form of an official letter, and must contain the following information:

- (a) The ship from which it comes.
- (b) The dates between which the ship will be available, and its location.
- (c) The bureau having cognizance (BuShips for all electronic equipment).
- (d) Whether the work is urgent repairs, desirable repairs or alterations.
- (e) A complete and easily understandable description of the work required. Usually the work must be done by men who are unfamiliar with the ship or the complete installation on which the repairs are to be made. Therefore, it is very important that all necessary information be given in sufficient detail. Drawings, blueprints, sketches and other references should be included wherever they will aid in the explanation.
  - (1) If a defective unit or part is to be repaired separately, it is best to take the unit and the approved work request personally to the tender or yard so that any additional information the repair shop may need can be given promptly.
- (f) What assistance the ship's force will provide, and who will be available for consultation or supervision.
- (g) A statement that the work is beyond the scope of the ship's force.
- (h) The signatures of the head of the department and of the Commanding Officer.

Whenever possible, the tender or Navy Yard should be notified well in advance of the date actual repairs are requested, especially if the ship must be docked during repair.

The responsibility of the technician in preparing work requests will vary with the size of the repair job and of the ship. In any case, the technician must furnish a clear and exact description of the technical requirements of the job, written in a manner that workmen in other trades can understand.

MISCELLANEOUS SUPPLIES. Any supplies or parts carried in stock by the ship's general store room (GSK) may be drawn with a Stub Requisition, S and A Form 307, signed by the head of the department requesting the supplies. Regular equipment spare parts usually are turned over to the radio department and are stored near the equipment, but GSK may carry some of them, or may have equivalent stock parts.

Official Form  
S and A 307,  
half size.

U. S. S. <u>RMS, T. I.</u>		Stub Requisition No. _____			
To SUPPLY OFFICER: Request following stores be delivered to bearer for use in the Department.		29 Nov. 1944			
		<i>A. R. Smith</i> By authority of Head of Department.			
STANDARD STOCK OR GSK No. or Class No.	DESCRIPTION OF ARTICLE	QUANTITY REQUIRED	UNIT OF QUANTITY	UNIT PRICE	EXTENSION
	SCREWS BRASS 8-32 1 INCH	1	GROSS		
	NUTS BRASS 8-32 HEX	1	GROSS		
	PLIERS LINEMAN 6 INCH	1	NO.		
Received the above material.				TOTAL	
ISSUED BY: _____			Charged on Ledger, _____		
_____ Store Room Keeper.			_____ U. S. N. Allotment charged, _____		

Fig. 35 Official Stub Requisition for Miscellaneous Supplies.

OBSCURE TROUBLES IN RECEIVERS

These are troubles which cannot readily be detected by abnormal current, voltage, or resistance readings. Important symptoms and causes are:

1. LACK OF SENSITIVITY, due to:

- (a) Defective coupling (open coil or coupling capacitor).
- (b) Misalignment.
- (c) Faulty connections (high resistance joints or corroded joints).
- (d) Defective tubes which check good on tube checker.
- (e) Defective parts, especially intermittent defects.

2. OSCILLATION:

- (a) The combination of an incoming signal and an undesired oscillation in the receiver IF stages may produce an audible beat note. As the receiver is tuned nearer to the incoming frequency, the pitch of the beat note will decrease.
- (b) Interference between two stations also may cause an audible beat note in the receiver output, but in this case the pitch of the note will not change as the receiver is tuned.
- (c) The removal of the antenna, or insufficient antenna, may decrease the receiver input loading enough that the energy fed back from following stages may cause oscillation.
- (d) Interstage coupling between plate and screen circuits, or unintended feedback in any circuit may cause oscillation.
- (e) Excessive plate or screen voltage may cause some stages to oscillate.

## RECEIVER SERVICING

3. **IMAGE RECEPTION (SUPERHETS ONLY):** The frequency of the interfering signal differs from that of the desired signal by twice the IF of the receiver. When mixed with the output of the local oscillator, both incoming signals produce the receiver IF, and both are reproduced. Causes are:
  - (a) Insufficient selectivity in the RF stages.
  - (b) Poor shielding.
  - (c) Excessively strong interfering signal.
  
4. **INTERMITTENT RECEPTION:** This usually is due to momentary shorts or opens in transformers, resistors or capacitors; leaky capacitors, high resistance contacts or joints, etc. May be caused by:
  - (a) Voltage breakdown of insulation.
  - (b) Expansion of parts from heat.
  - (c) Mechanical failures such as broken leads, poor connections, loose shielding, bent capacitor plates, etc.

When checking for obscure troubles or intermittent operation, take nothing for granted. Check everything thoroughly and systematically.

### NOISE

1. **TESTS TO DISTINGUISH BETWEEN INTERNAL AND EXTERNAL NOISE:**
  - (a) Disconnect the antenna lead-in, and short the receiver antenna and ground terminals. A reduction in noise indicates that external noise is picked up by the antenna.
  - (b) If the noise remains, remove the ground lead to eliminate the possibility that the ground lead is feeding in noise.
  - (c) If the noise still remains, it is either entering through the power supply or is being generated within the receiver.
    - (1) Internal noise may be isolated by removing and replacing tubes one at a time.
  
2. **INTERNAL NOISE:** May be caused by:
  - (a) Thermal agitation, mainly in carbon resistors.
  - (b) Shot effect due to uneven or irregular space current in vacuum tubes.
  - (c) Microphonic effects, mainly from mechanical vibration of tube elements.

The amount of internal noise in the first RF stage determines almost entirely what the standard sensitivity of the receiver will be.
  
3. **EXTERNAL NOISE:**
  - (a) Natural, due to atmospheric conditions such as electrical storms or "static".
    - (1) No practical method of eliminating natural static has been discovered.
  - (b) Man-made, due to buzzers, blinkers, switches, relay contacts, medical apparatus, motors, generators, etc.
  
4. **METHODS OF ELIMINATING NOISE:**
  - (a) The most effective method of tracking down the noise source is to



station one man at the receiver to note any change in noise, while another man starts and stops each piece of equipment and checks any other possible source.

- (b) After the noise source has been found, check the offending equipment to make sure it is operating properly and does not require adjustment or overhauling.
  - (1) If noise persists when the offending equipment is in good condition, a filter will be necessary.
  - (2) Filters should be placed as close to the noise source as possible.

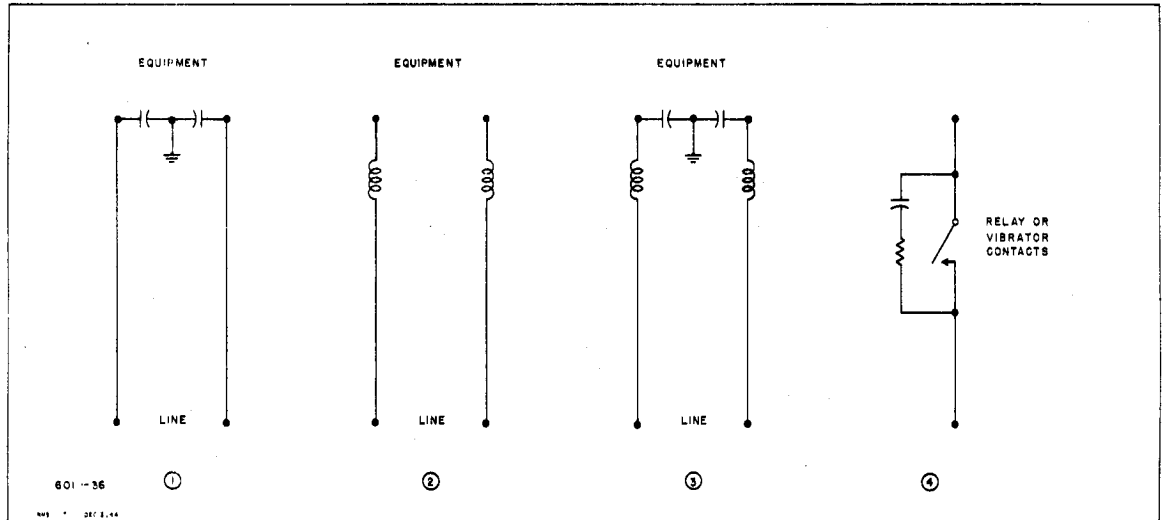

Fig. 36 Typical noise filters.

**TYPE 1:** Capacitors alone are easy to install, and usually are sufficient for small equipment where the noise is not of high amplitude. Common sizes of capacitors for all four types of filter are from .1 to 2  $\mu\text{f}$ , with voltage rating at least twice the operating voltage.

**TYPE 2:** Inductances alone are much less effective, but can be improvised easily, and may help considerably if no suitable capacitors are available. The inductances must have sufficient current-carrying capacity and insulation, should have high impedance to noise frequencies but low impedance to the line frequency.

**TYPE 3:** Combined series inductance and shunt capacity is by far the most effective line filter. This type may be made resonant to eliminate even high amplitude interference at any one frequency. More sections may be added if necessary.

**TYPE 4:** This resistance-capacity combination is very effective for suppressing arcs at contacts such as relay, buzzer, vibrator, etc. The resistor must have ample wattage rating, and approximately one ohm per volt. Less resistance suppresses the noise better, but causes the contacts to burn.

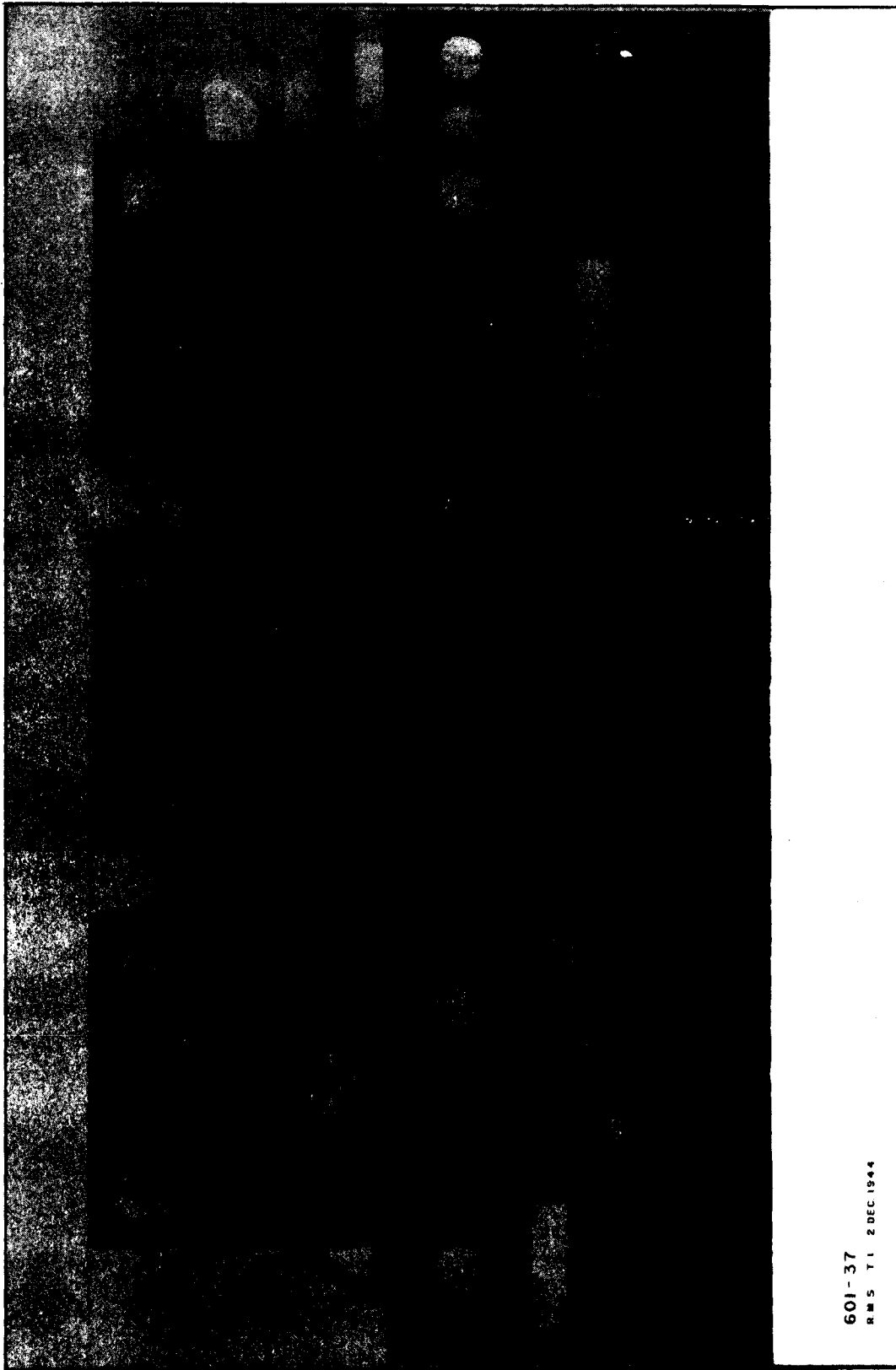

601-37  
RMS T I 2 DEC 1944

Fig. 37 Typical Navy complete receiving equipment: RBA, RBB and RBC receivers and power supplies.

<p><b>RBA</b> Frequency range 15 kcs to 600 kcs TRF Average standard sensitivity 4 <math>\mu</math>v</p>	<p><b>RBB</b> Frequency range 500 kcs to 4 mcs Superhet - IF 400 kcs Average standard sensitivity 4 <math>\mu</math>v</p>	<p><b>RBC</b> Frequency range 4 mcs to 27 mcs Superhet - IF 400 kcs Average standard sensitivity 7 <math>\mu</math>v</p>
<p>IF - AF units of RBB and RBC are identical.</p> <p>An analyzer such as an OAE is necessary for taking voltage measurements from tube sockets in the preselector unit under operating conditions.</p>		
<p>All three receivers may be operated from the same antenna by following the procedure listed in the instruction book.</p>		

**POWER SUPPLY UNITS**

The rectifier power supply units are interchangeable. Two outlet plugs are provided on each unit so that in an emergency any two receivers can be operated from the same power unit.

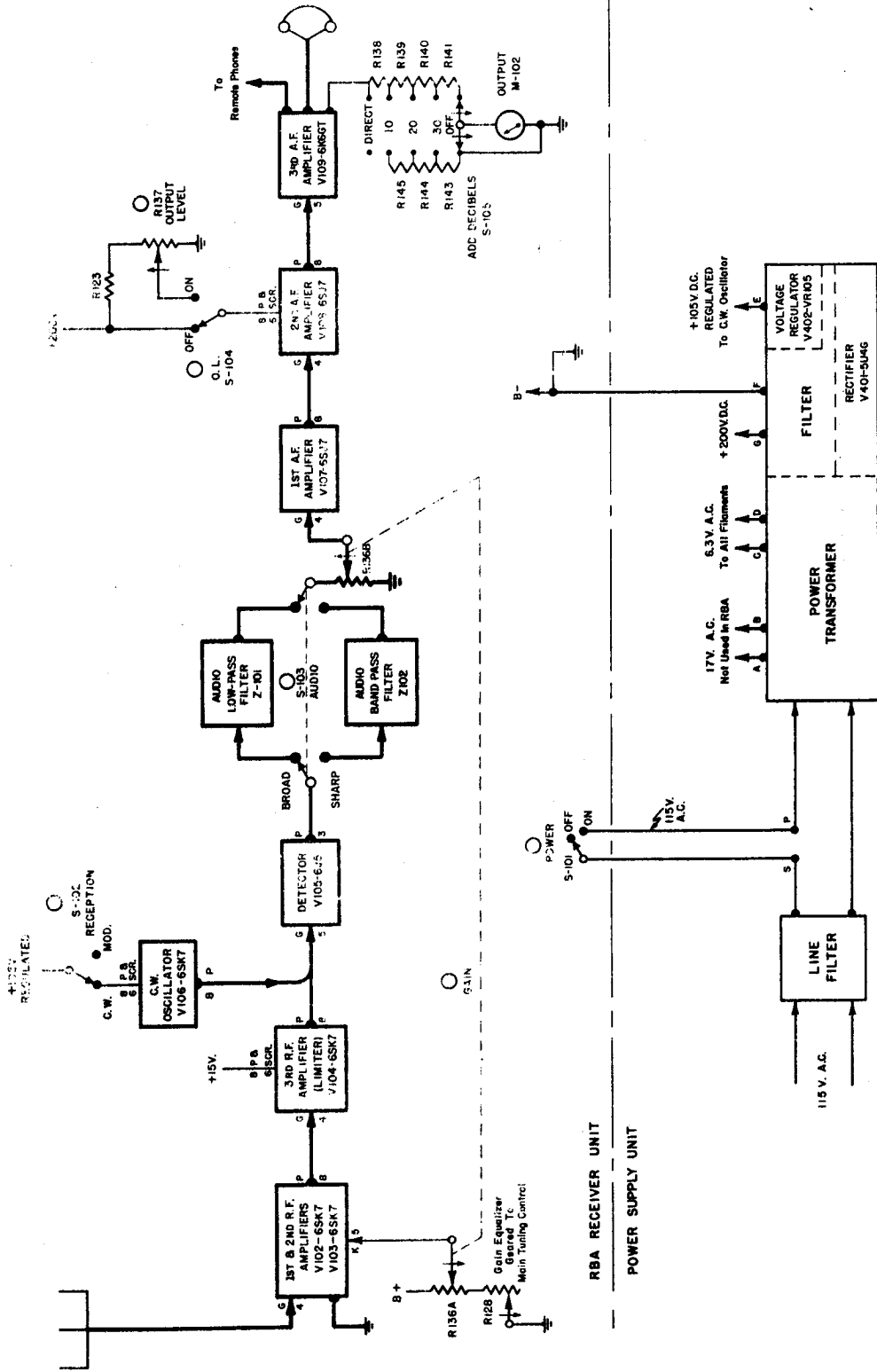

601-38  
 AND T. M. C. 111

Fig. 38 RBA Receiver and power supply, block diagram.

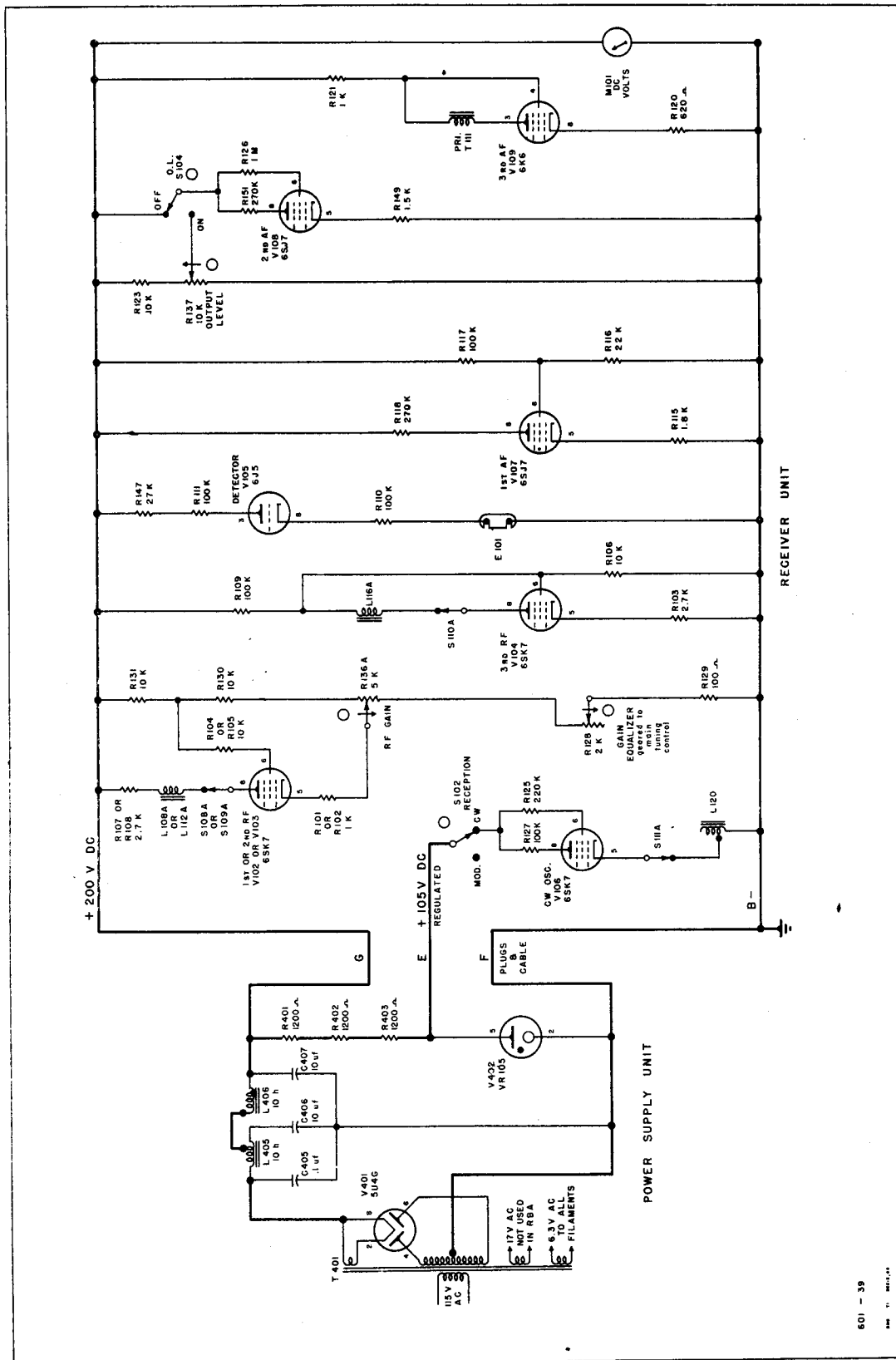

Fig. 39 DC power distribution of RBA Receiver.

# RECEIVER SERVICING

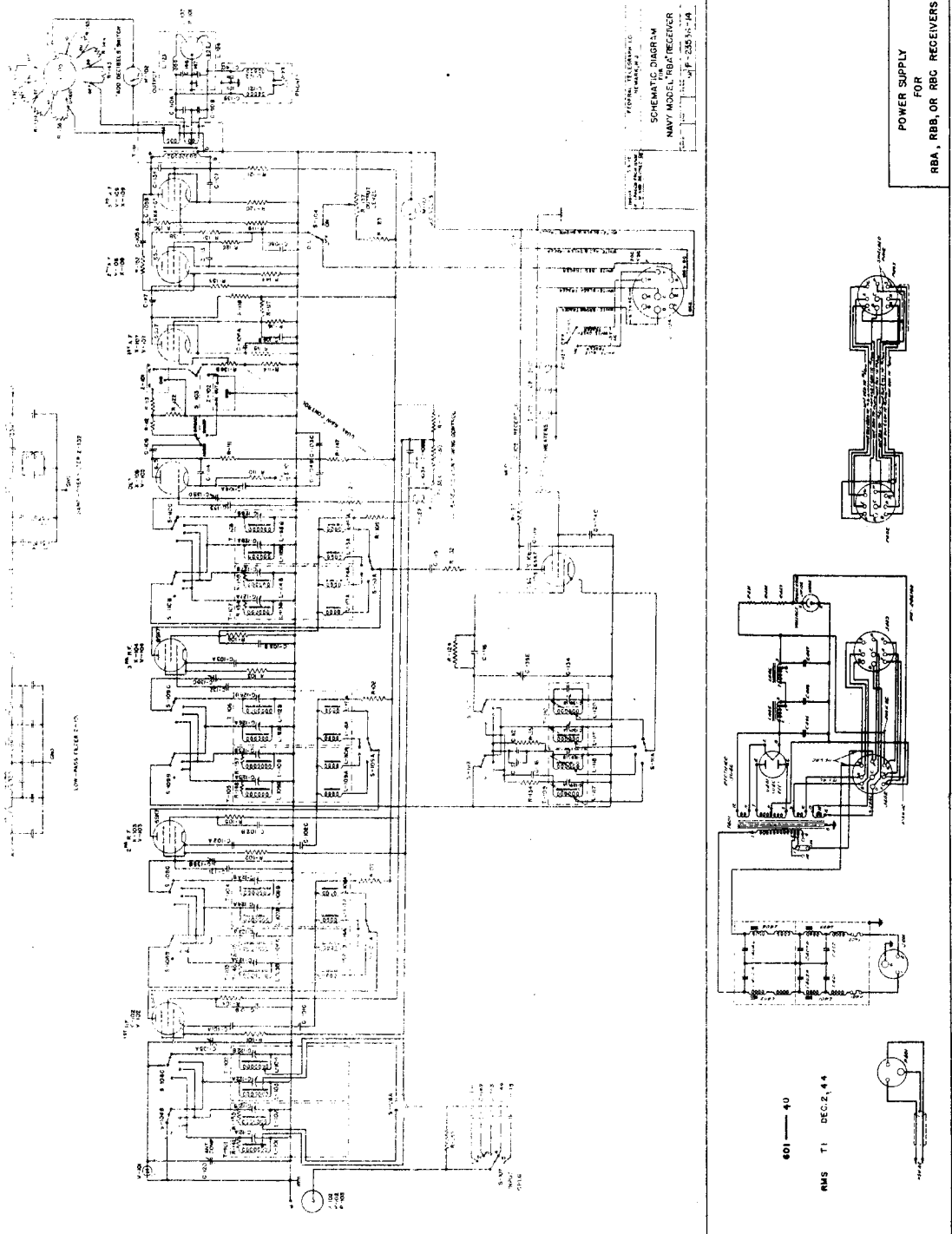

Fig. 40 RBA Receiver and power supply, manufacturer's schematic diagram.

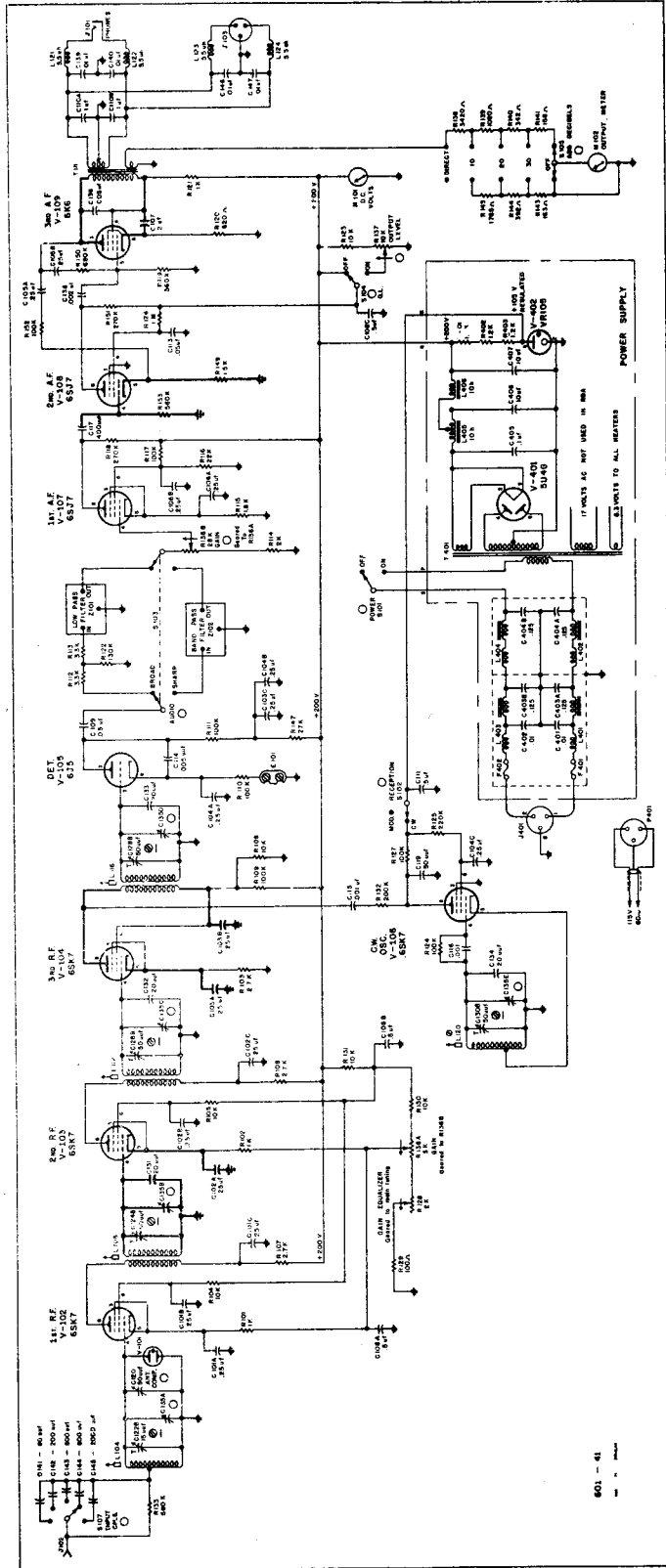

Fig. 41 RBA Receiver, simplified schematic, drawn in Band 4 position.

ANTENNA INPUT

S-107 provides an approximate impedance match in the input system for different antennas.

C-120 is a fine adjustment of the impedance controlled by S-107.

V-101 neon bulb will fire at about 87 volts to protect the receiver input against higher voltages.

R-133 is a static discharge resistor.

R-136A, RF GAIN or sensitivity control, varies the cathode voltage (bias) of these two stages.

1st and 2nd RF

Screen and plate of V-104 are operated at only 15 volts to prevent overloading the detector input.

3rd RF

Link E-101 is for inserting a microammeter for alignment or sensitivity measurements.

DETECTOR

1st AF

R-136B, audio volume control, is mechanically ganged with the GAIN control.

2nd AF

Operates as an output limiter when O.L. switch S-104 is ON. Degeneration is the same as in 3rd AF.

3rd AF

Degeneration allows impedance mismatch (1 to 20 sets of phones) with little change in volume.

CW OSCILLATOR

Electron coupled circuit, output tracking 1,000 cycles above the incoming signal.

## RECEIVER SERVICING

**VARIABLE-MU TUBES FOR GAIN CONTROL:** Used in RF amplifiers so the gain or sensitivity may be varied by changing the bias, either manually or with AVC.

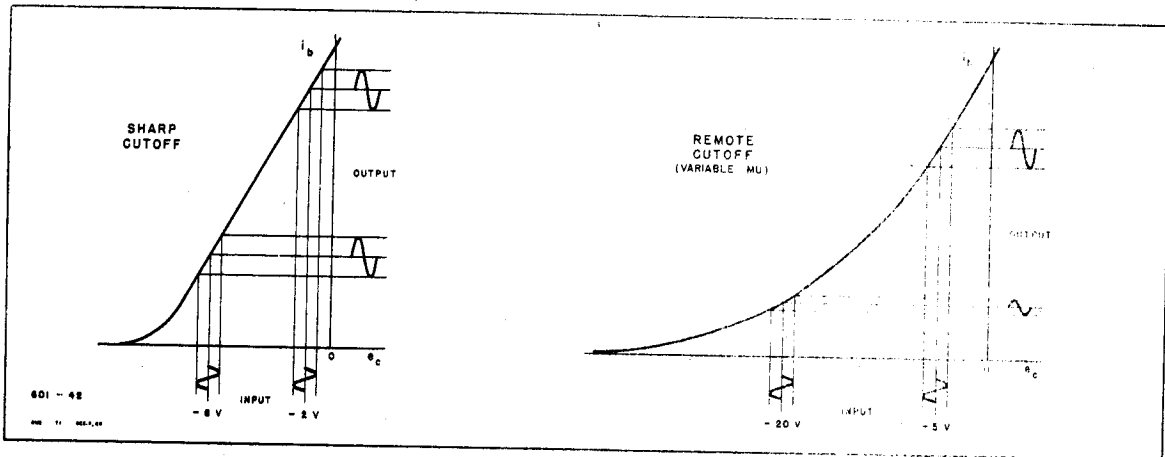

Fig. 42 Comparison of the characteristics of remote and sharp cutoff pentodes.

**REGENERATION:** Decoupling networks are necessary to prevent voltage surges or signal potentials from coupling from one stage to another through the common impedance of the power supply. The ratio of the reactance of C to R at the lowest signal frequency should be approximately 1 to 10.

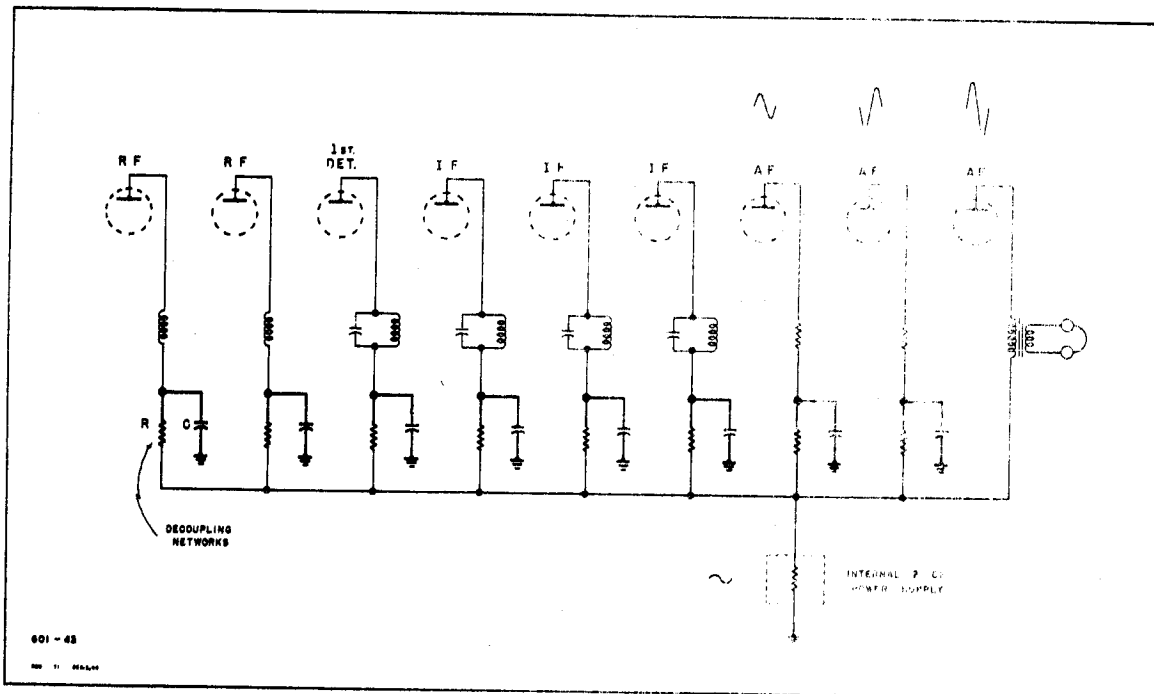
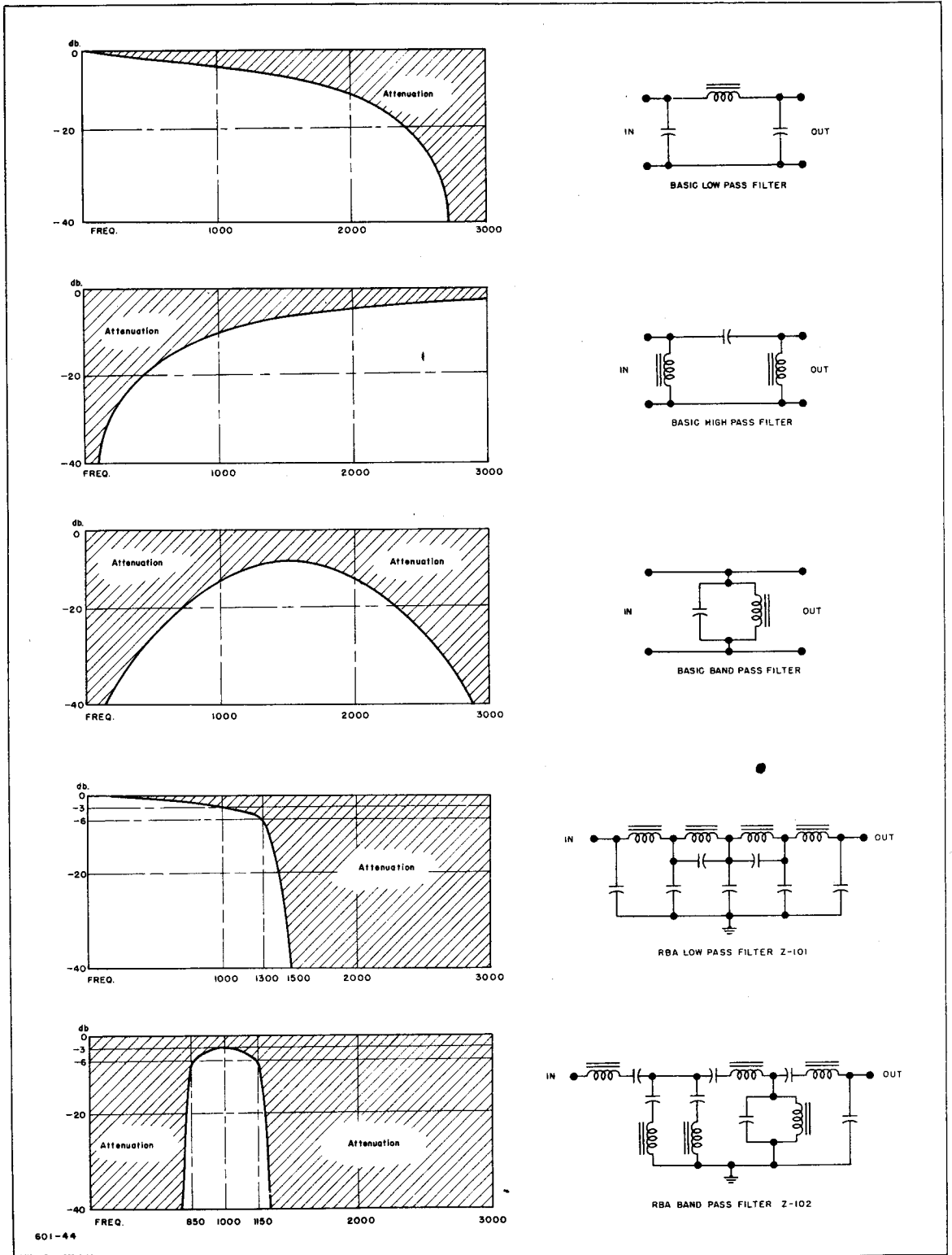

Fig. 43 Decoupling filters to minimize feedback through the power supply.



**PURPOSE:** To improve the overall sensitivity and selectivity of the receiver.



**Fig. 44 Basic and RBA audio filters.**

The purpose of a noise limiter in a radio receiver is to suppress strong noise impulses of a short duration such as those caused by sparking contacts and atmospheric static. A good noise limiter will enable the operator to obtain intelligence from the signal under adverse conditions.

SHUNT TYPE NOISE LIMITER:

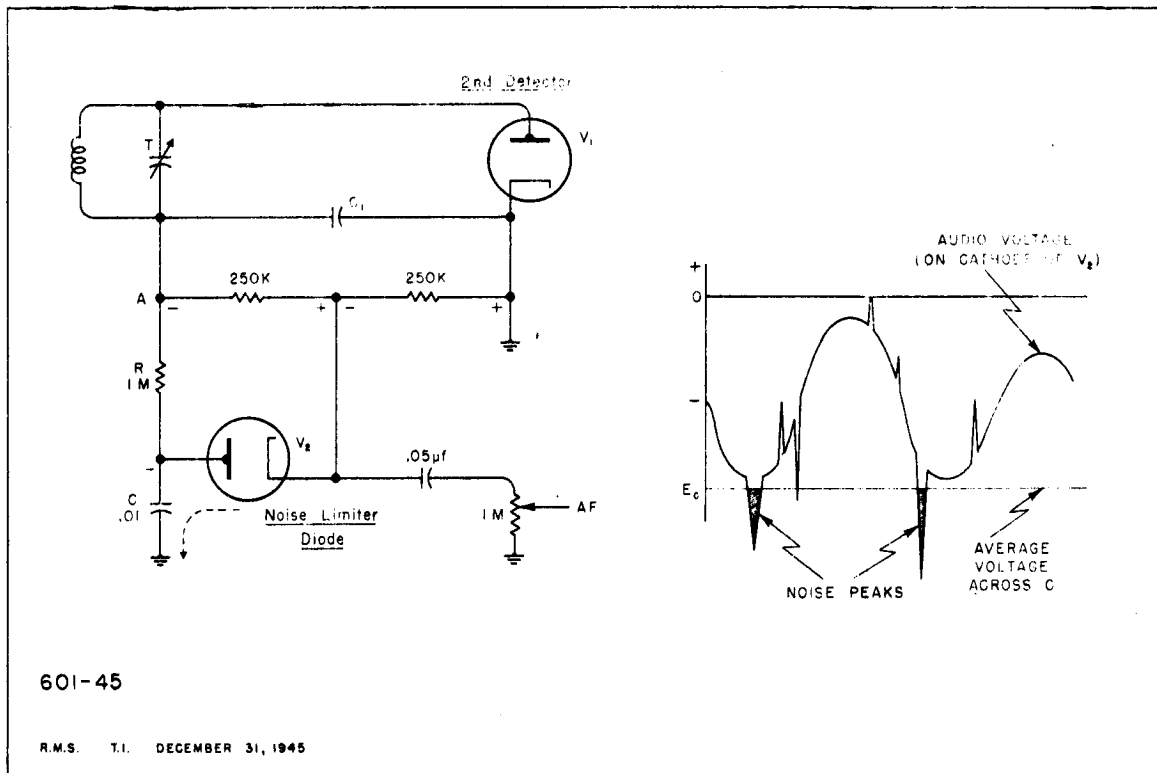

Fig. 45 Shunt type noise limiter.

1. GENERAL CIRCUIT CONDITIONS:

- (a)  $V_1$  is the second detector.
- (b)  $V_2$  is the noise limiter diode.
- (c) With a signal present  $C$  will charge up to the average negative voltage at point  $A$ . The voltage charge on  $C$  is applied to the plate of  $V_2$ . The plate voltage on  $V_2$  will not vary with modulation.
- (d) The cathode voltage of  $V_2$  will vary with modulation as shown above but  $V_2$  will not conduct as long as the cathode voltage is less negative than the plate voltage.

2. OPERATION:

- (a) Under normal conditions, no noise present, the noise limiter diode,  $V_2$ , will not conduct and the audio signal is coupled to the next stage.
- (b) A noise pulse strong enough to drive the cathode negative in respect to the plate (the plate voltage is fixed to the charge on  $C$ ) will cause  $V_2$  to conduct.
- (c) When  $V_2$  conducts the noise pulse will be shunted through the diode and  $C$  to ground.
- (d) The noise voltage pulse applied to the output will be limited to a value that causes the diode to conduct.

3. RESULT: The limiting of strong noise pulses will improve reception.

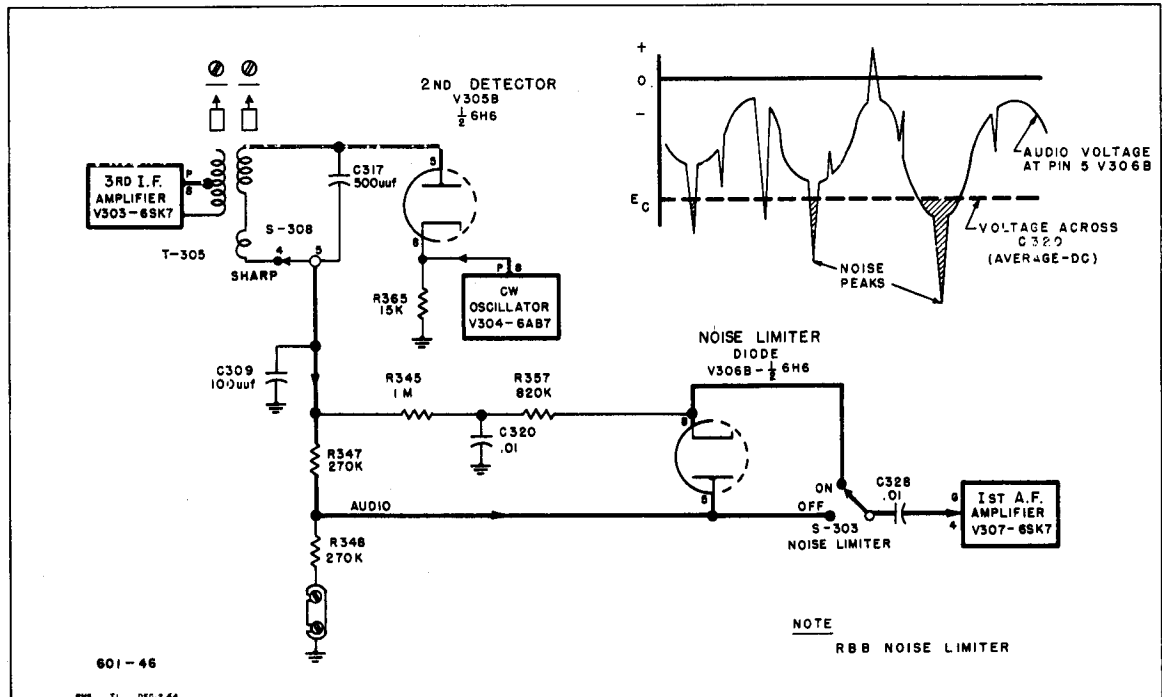

Fig. 46 Series type noise limiter.

1. **GENERAL CIRCUIT CONDITIONS:** V-306B (pins 5 and 8) is used as a series type noise limiter, so named because the diode is in series with the audio path and must be conducting for the audio signal to pass.
2. **OPERATION:**

Normal signal, no noise peaks:

  - (a) The voltage drop across the 2nd detector load resistors R-347 and R-348 causes the plate of V-306B to be positive with respect to its cathode.
  - (b) V-306B will conduct and will remain conducting under normal signal conditions.

Signal with high noise peaks:

  - (a) The voltage drop across the 2nd detector load resistors R-347 and R-348 increases sharply during noise peaks.
  - (b) R-345 and C-320 form a filter network to prevent the voltage on the cathode of V-306B from changing instantaneously.
  - (c) The voltage on the plate of V-306B follows the instantaneous changes in voltage across R-348, and swings sharply negative with respect to the cathode so V-306B will not conduct during the noise surge.
  - (d) With V-306B not conducting, the audio line is open for the duration of the noise surge.
3. **RESULTS:** The receiver output is turned off during the brief noise periods and in some cases during part of the modulation cycle which causes some distortion.

## RBL RECEIVER OUTPUT LIMITER

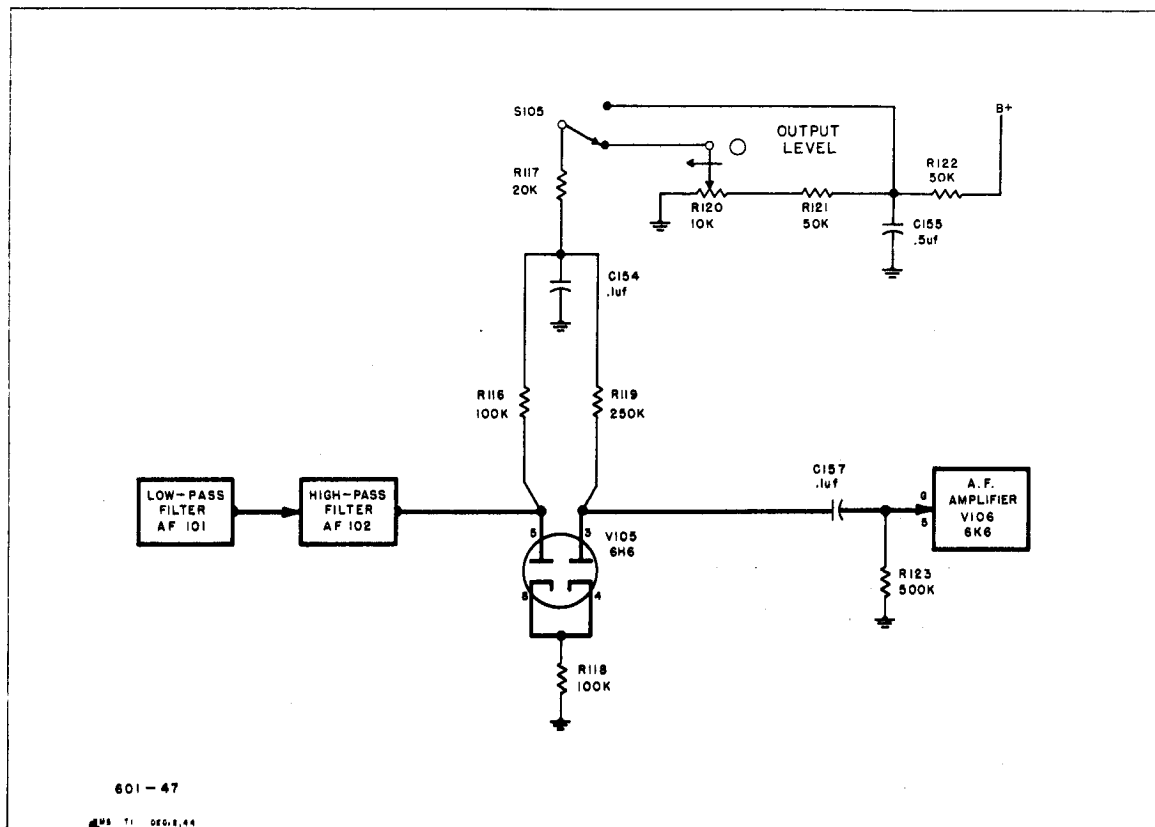

Fig. 47 RBL Receiver output limiter.

1. **PURPOSE:** To limit all audio peaks to a definite maximum value determined by the setting of the **OUTPUT LEVEL** control R-120.
2. **OPERATION:** Normal signal condition (no limiting action):
  - (a) R-120 is so adjusted that both halves of the 6H6 limiter tube V-105 are conducting all the time, thus allowing the audio signal to pass.

**OPERATION with limiting action:**

  - (a) A positive swing in signal on the plate (pin 5) of V-105 increases current flow through R-118. The cathode (pin 4) of the other half of the tube now will be positive with respect to its plate (pin 3), causing this half of the tube to be non-conducting and to open the audio line for the remainder of the positive peak of signal.
  - (b) A negative swing in signal causes the plate (pin 5) to become negative with respect to its cathode (pin 8), causing this half of the tube to be non-conducting and to open the audio line for the remainder of the negative peak of signal.
3. **RESULTS:** Both the positive and negative signal peaks are limited by the push-pull action of the double diode, thus maintaining a practically constant output for signal inputs exceeding normal strength. This circuit is very effective in limiting high instantaneous peaks of noise.

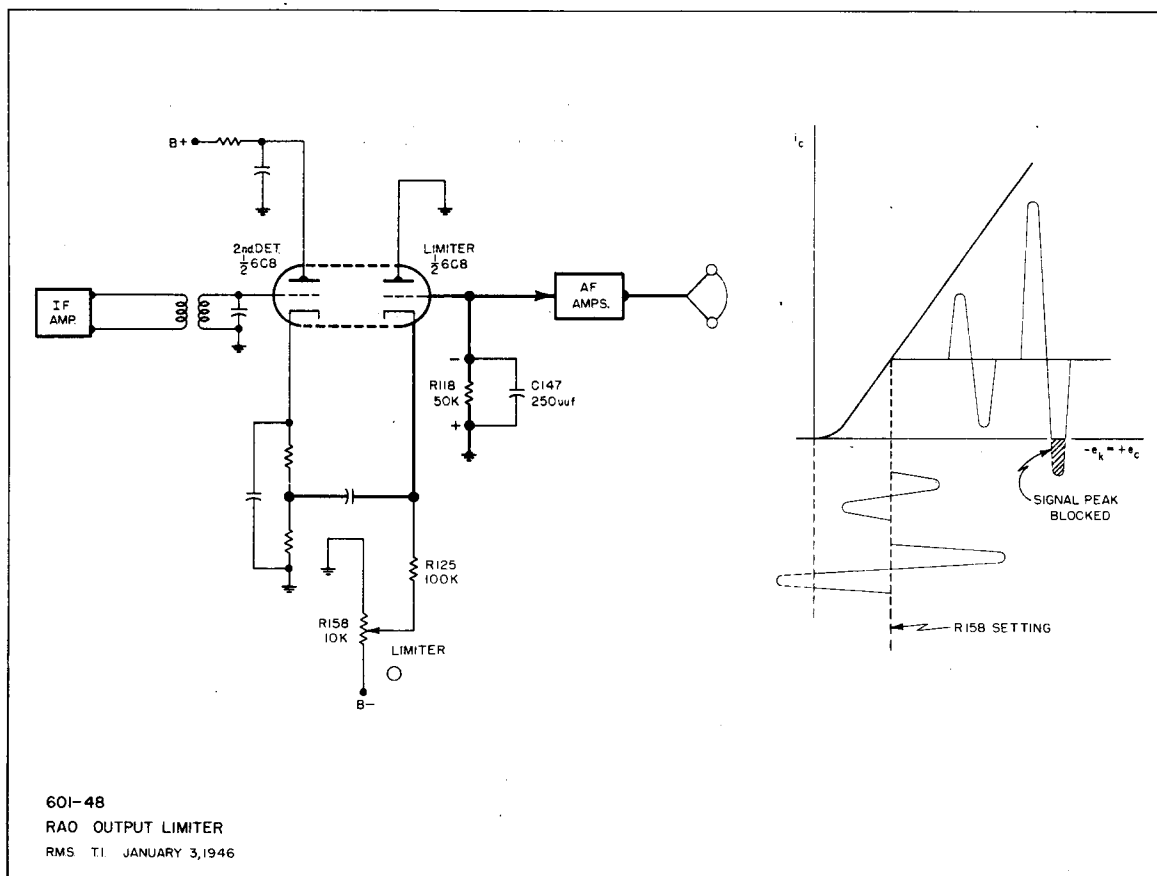

Fig. 48 RAO output limiter

1. **PURPOSE:** To limit peaks of audio signal and noise above a value determined by the setting of Limiter control R-158.
2. **OPERATION:**
  - (a) The limiter tube must be conducting at all times to pass audio variations. Audio variations of the current flowing from cathode to grid of the limiter and down through the grid resistor produce an audio voltage across R-118 which is applied to the audio-frequency amplifier.
  - (b) The setting of R-158 determines the amplitude of negative voltage on the limiter cathode.
  - (c) Positive signal swings which exceed the value of negative voltage on the limiter cathode will cause the limiter tube to stop conducting, thus opening the audio line during high positive peaks of signal or noise.
3. **RESULTS:** Since this type of limiter affects only the positive peaks of signal, the action will not be as great as in a limiter which functions on both halves of the audio cycle. However, this circuit is effective in limiting high instantaneous peaks of noise.

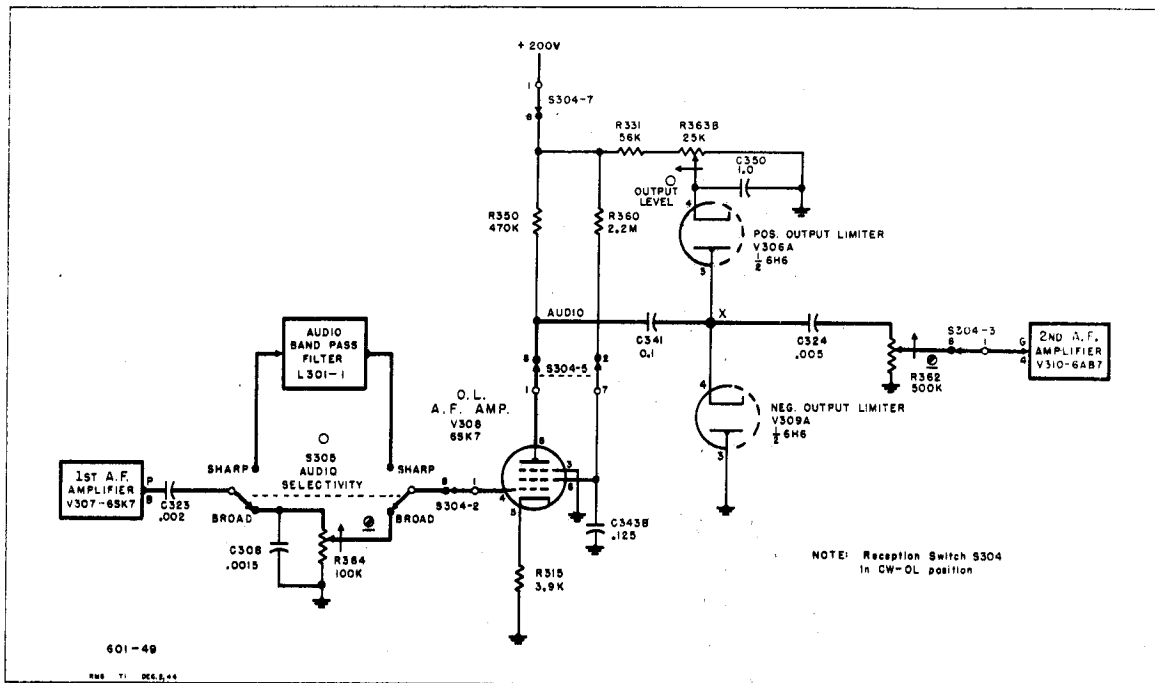
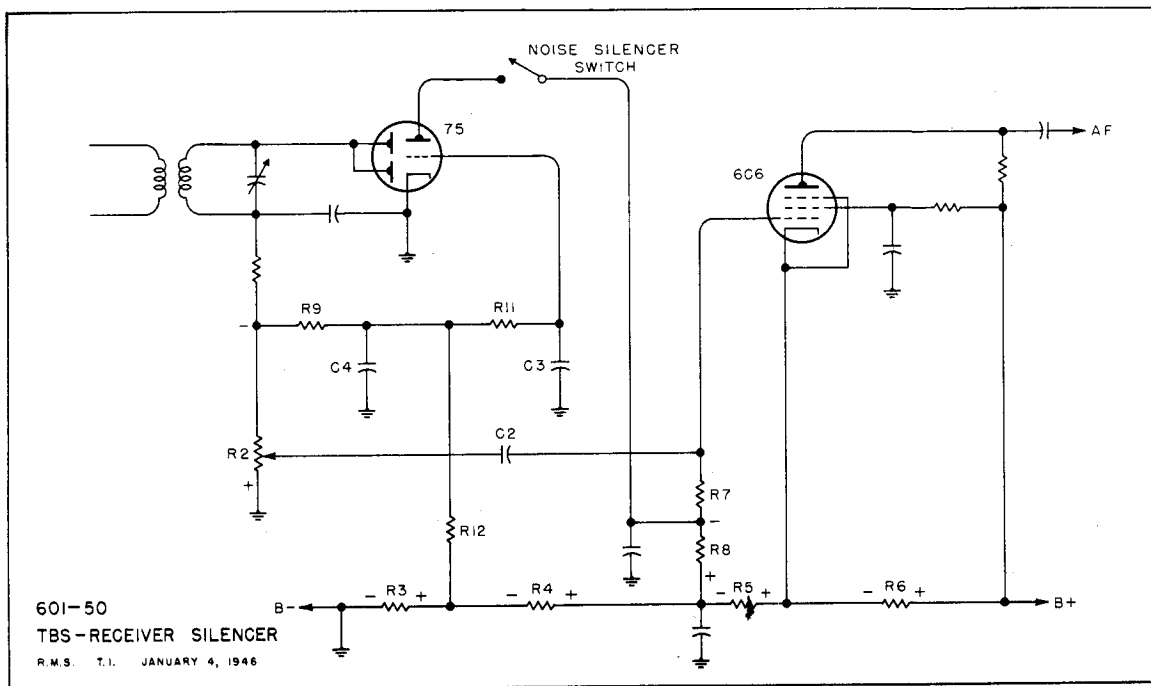

Fig. 49 RBB output limiter.

1. **PURPOSE:** To limit the output of the receiver to a level determined by the setting of the **OUTPUT LEVEL** control. (Reception switch in CW-OL position).
2. **GENERAL CIRCUIT CONDITIONS:** Two diodes operating as a full wave rectifier are shunted across R-350, the plate load resistor of V-308. V-306A limits the positive peaks, and V-309A limits the negative peaks.
3. **OPERATION:**
  - (a) The **OUTPUT LEVEL** control R-363B varies the cathode potential of V-306A from 0 to approximately +65 volts.
  - (b) V-306A and V-309A are connected in series between ground and the positive voltage determined by the setting of R-363B.
  - (c) The average voltage at point X will be approximately half the voltage applied to the cathode of V-306A.
  - (d) Since point X is in the audio path, any changes in audio voltage greater than the average voltage at point X will cause V-306A to conduct on positive peaks, and V-309A to conduct on negative peaks.
  - (e) The limiting action comes from the shunting effect the diodes have on the plate load resistor R-350 of V-308. The more the diodes conduct, the lower their plate to cathode impedance, and the greater the shunting effect on R-350.
4. **RESULTS:** The receiver output is held constant for wide variations of input, and instantaneous noise impulses are limited.

GENERAL NOTES

## RECEIVER SILENCER CIRCUITS



- PURPOSE:** To eliminate background noise from the receiver while awaiting the transmission of a signal. To make the receiver audio section inoperative when no signal is present at the antenna while the receiver is turned on.
- GENERAL CIRCUIT CONDITIONS:** Noise silencer switch open.

**OPERATION:** With no incoming signal the AVC action increases the amplification of electrical interference noises. Noise voltages are developed across R2 and are coupled to the grid of the 6C6 through C2. Class A bias for the 1st AF stage is developed across R5. The noise will be amplified and heard in the receiver output. An incoming signal also will be heard in the receiver output.
- GENERAL CIRCUIT CONDITIONS:** Noise silencer switch closed.

**OPERATION:** (Noise present, no signal): C4 and C3 charge to part of the positive voltage across R3 and make the grid of the 75 tube slightly positive. The 75 tube plate current flows down through R8 and increases the 6C6 bias. The 6C6 plate current cuts off thus preventing the noise from getting through to the receiver output.

**OPERATION (Strong signal tuned in):** A large negative voltage produced across R2 by the signal causes C4 and C3 to discharge and recharge to the opposite polarity. The negative charge on C3 cuts off the 75 plate current flow reducing the bias on the 6C6. The 6C6 is unblocked and the audio signal is amplified in a normal manner.
- NOTE:** The noise silencer should not be used while tuning for signals (in variable tuning receivers) because: (1) weak signals will not get through the receiver and (2) the operator may tune past the station before the receiver has had time to unblock. The noise silencer should not be used during the reception of CW signals.



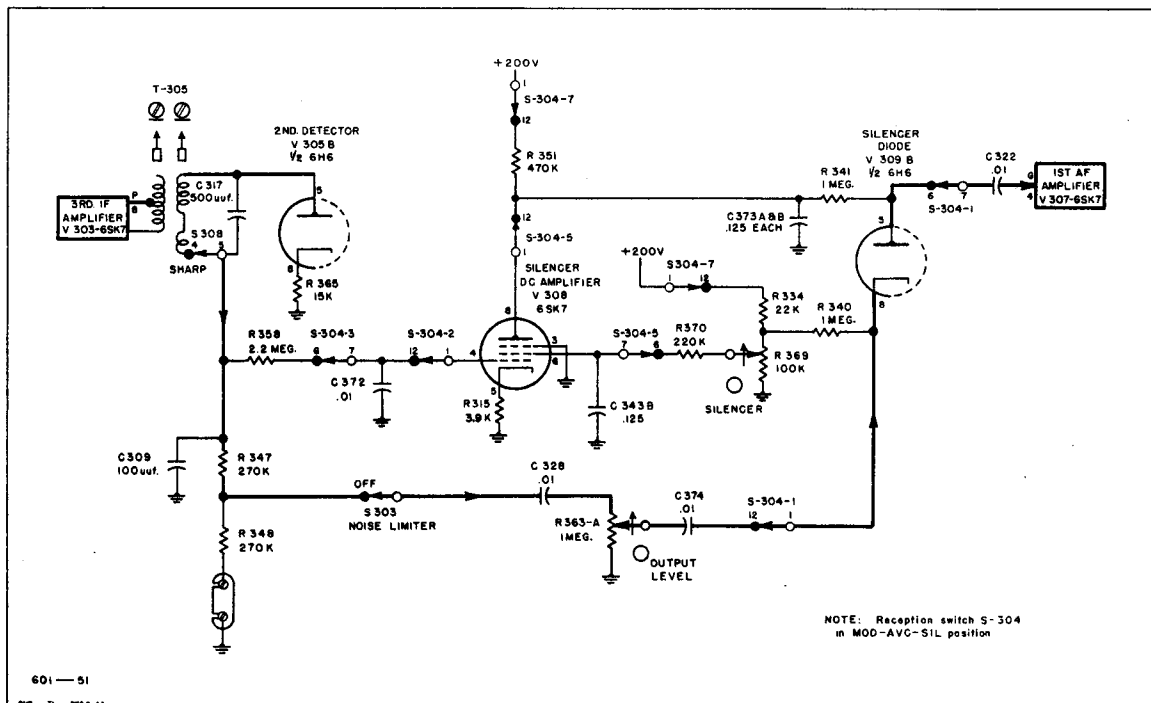
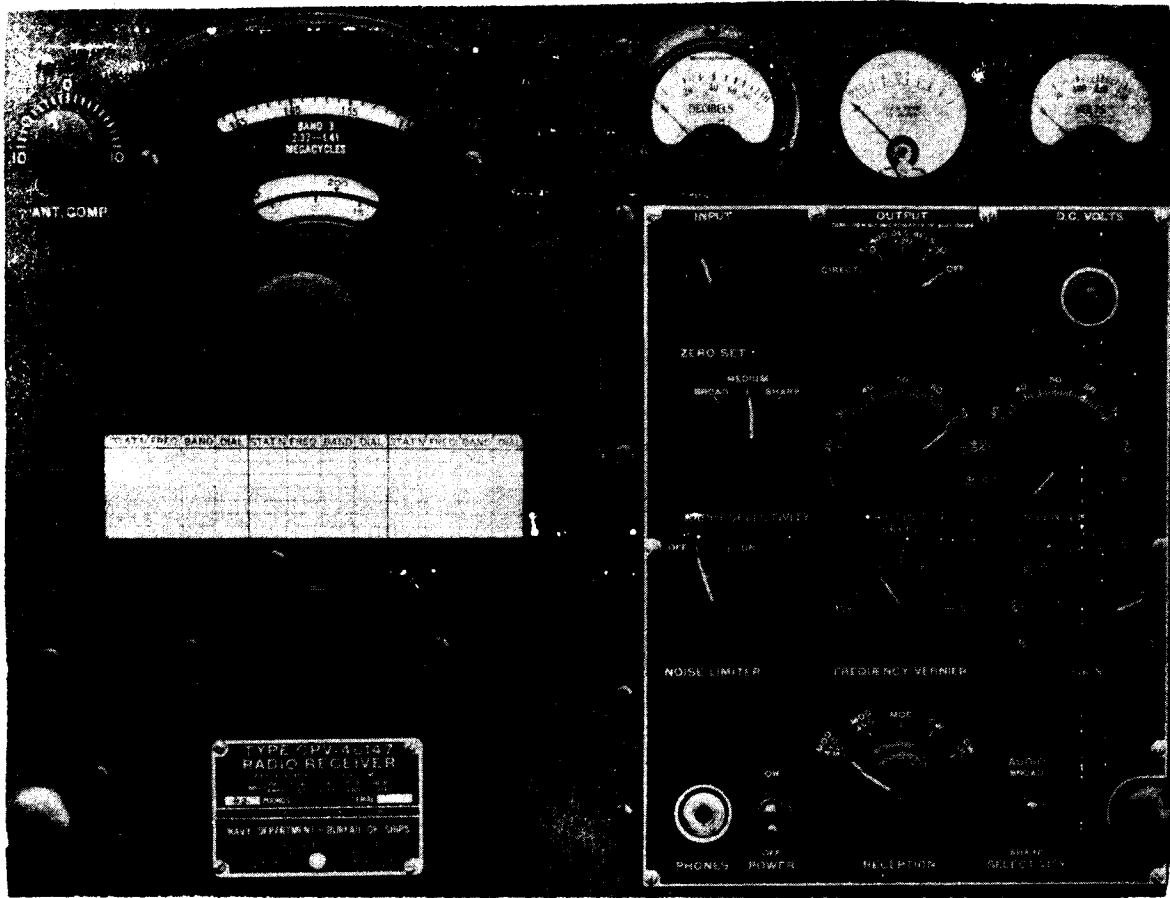

Fig. 51 RBB silencer circuit.

1. **PURPOSE:** To render the audio section of the receiver inoperative when no signal is present at the antenna.
2. **GENERAL CIRCUIT CONDITIONS:** V-308 is a DC amplifier used as a control tube for the silencer diode V-309B (pins 5 and 8). V-309B serves as a switch in series with the audio line. When conducting, V-309B allows the audio signal to pass. When V-309B is not conducting, the audio line is open.
3. **OPERATION:** No-signal condition: V-308 conducting maximum. V-309B not conducting, so the audio line now is open.
  - (a) A high positive voltage is applied to the cathode of V-309B.
  - (b) The setting of the SILENCER control R-369 is such that V-308 conducts.
  - (c) V-308 plate current through R-351 causes sufficient drop across R-351 to keep the plate of V-309B negative with respect to its cathode.

**SIGNAL CONDITION:** V-308 not conducting. V-309B conducting.

  - (a) The negative signal voltage developed across the detector load resistors R-347 and R-348 drives the control grid of V-308 to cutoff.
  - (b) No current through R-351 allows the voltage on the plate of V-309B to become positive with respect to the cathode.
  - (c) V-309B now is conducting and the audio line is closed.
  - (d) R-358 and C-372 form an audio filter to prevent the negative bias on the control grid of V-308 from varying at the audio rate.
4. **RESULTS:** The silencer circuit prevents noises from being heard between messages when the receiver is tuned to a station that transmits only intermittently.



CONTROL	OPERATIVE IN POSITION SHOWN			
ZERO SET	R321			
OUTPUT LEVEL	R363A			R363B
SILENCER	R369			
FREQ. VERNIER				C301
GAIN				R361A AND B

all other controls are operative in all positions of the RECEPTION switch.

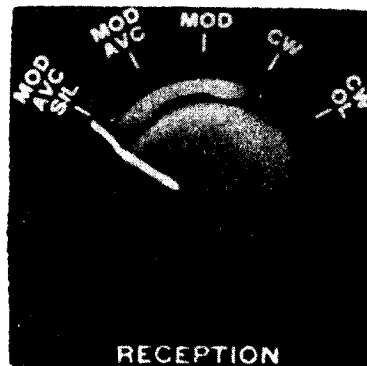

601-52  
R.M.S. T.I. 2 DEC 1944

Fig. 52 REB front panel controls.

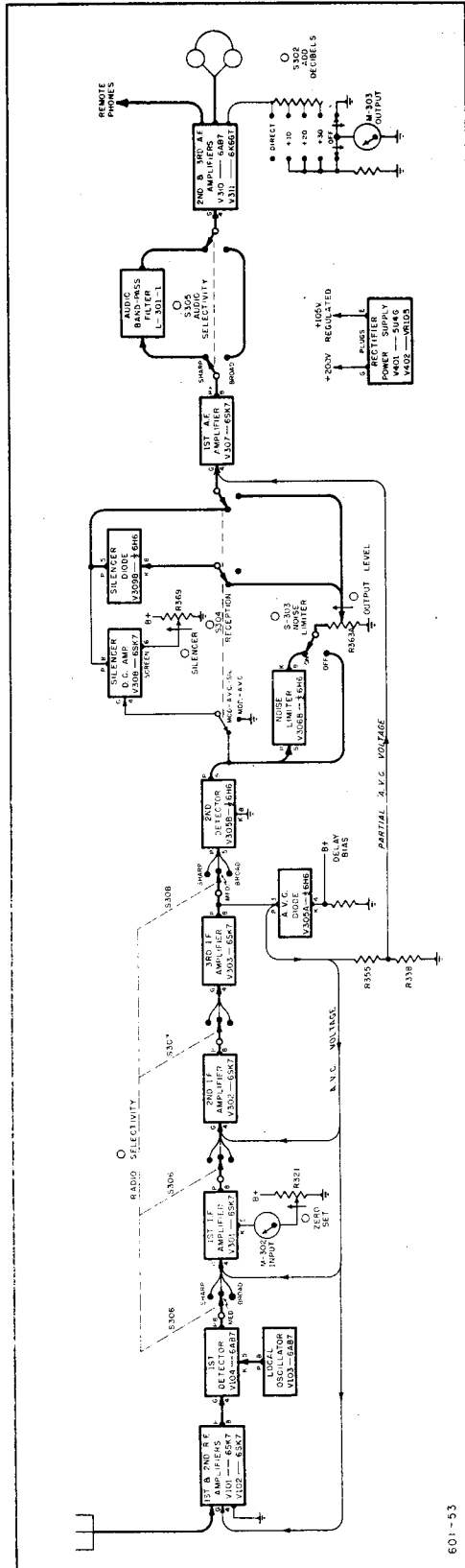

601-53

Fig. 53 RBB Receiver with RECEPTION switch in either MOD-AVC-SIL or MOD-AVC position.

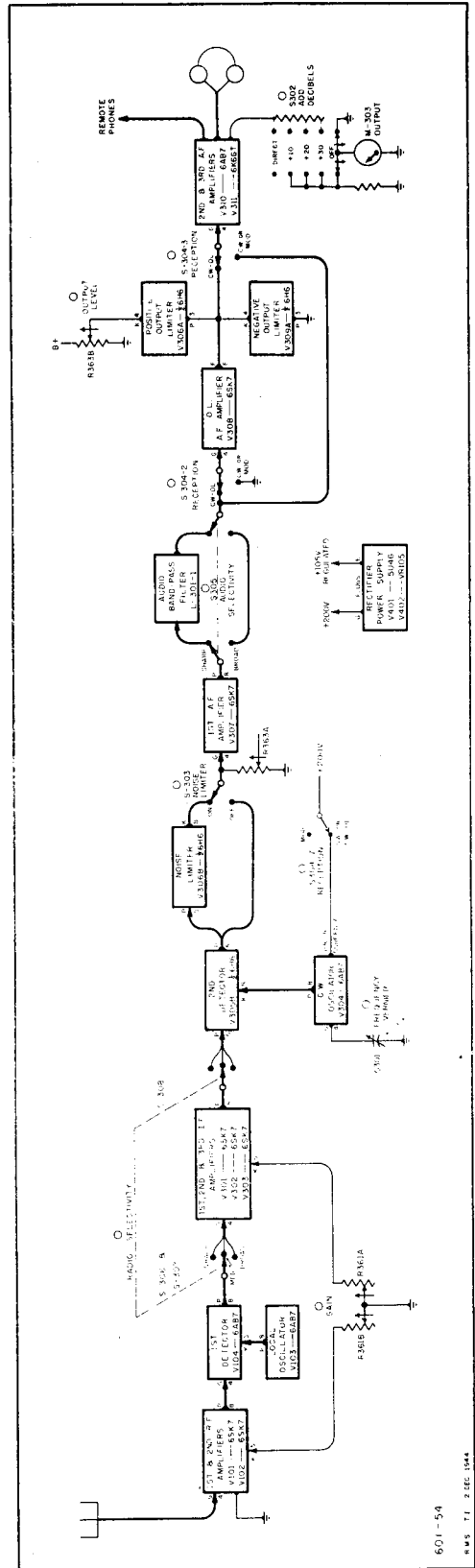

601-54

Fig. 54 RBB Receiver with RECEPTION switch in any one of three positions MOD, CW or CW-CL.



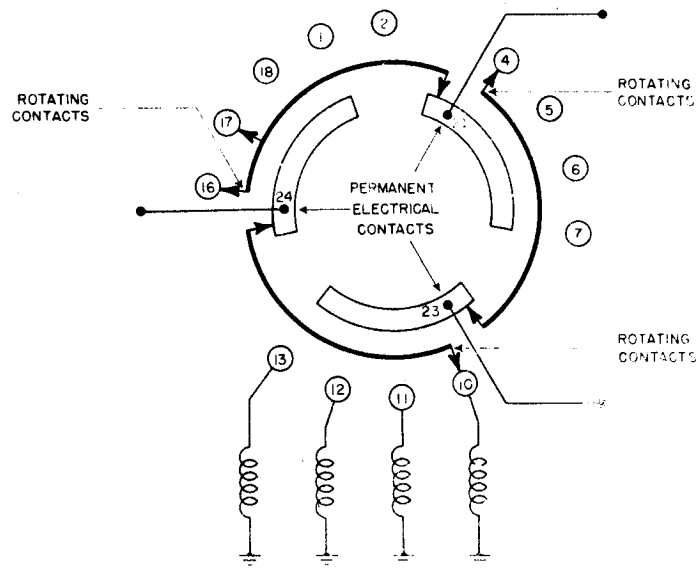

BAND SWITCH

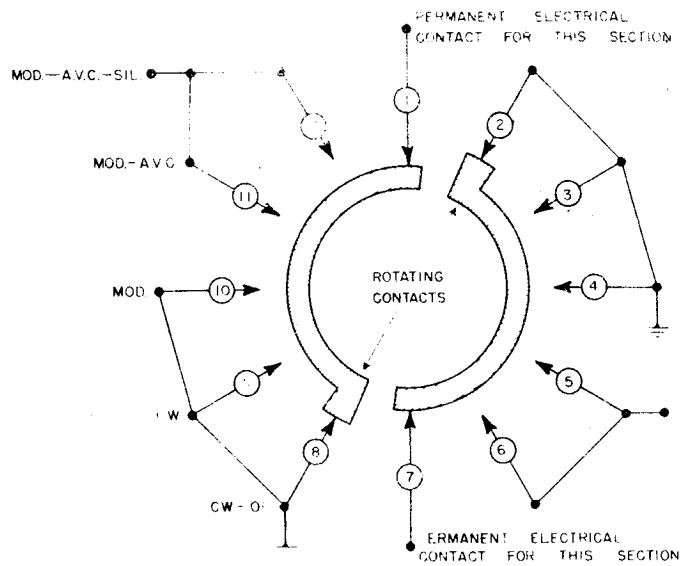

RECEPTION SWITCH

601-56

RMS 71 000 7.44

Fig. 56 Details of multiple contact switches.

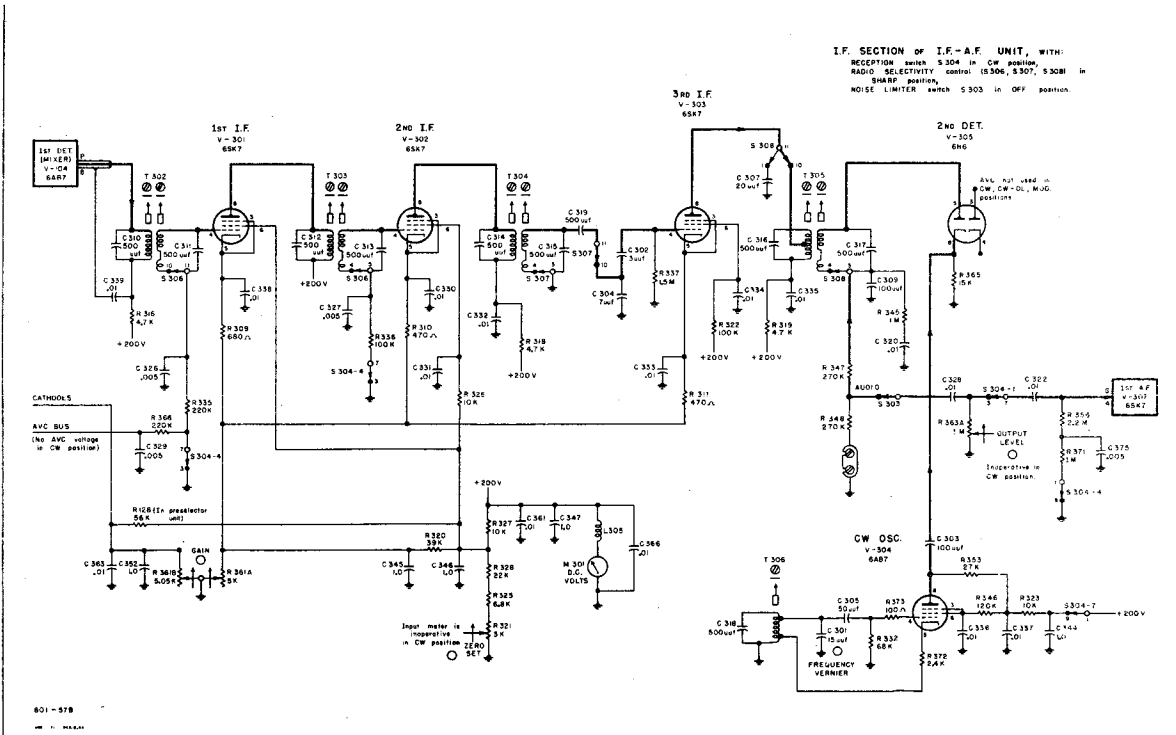
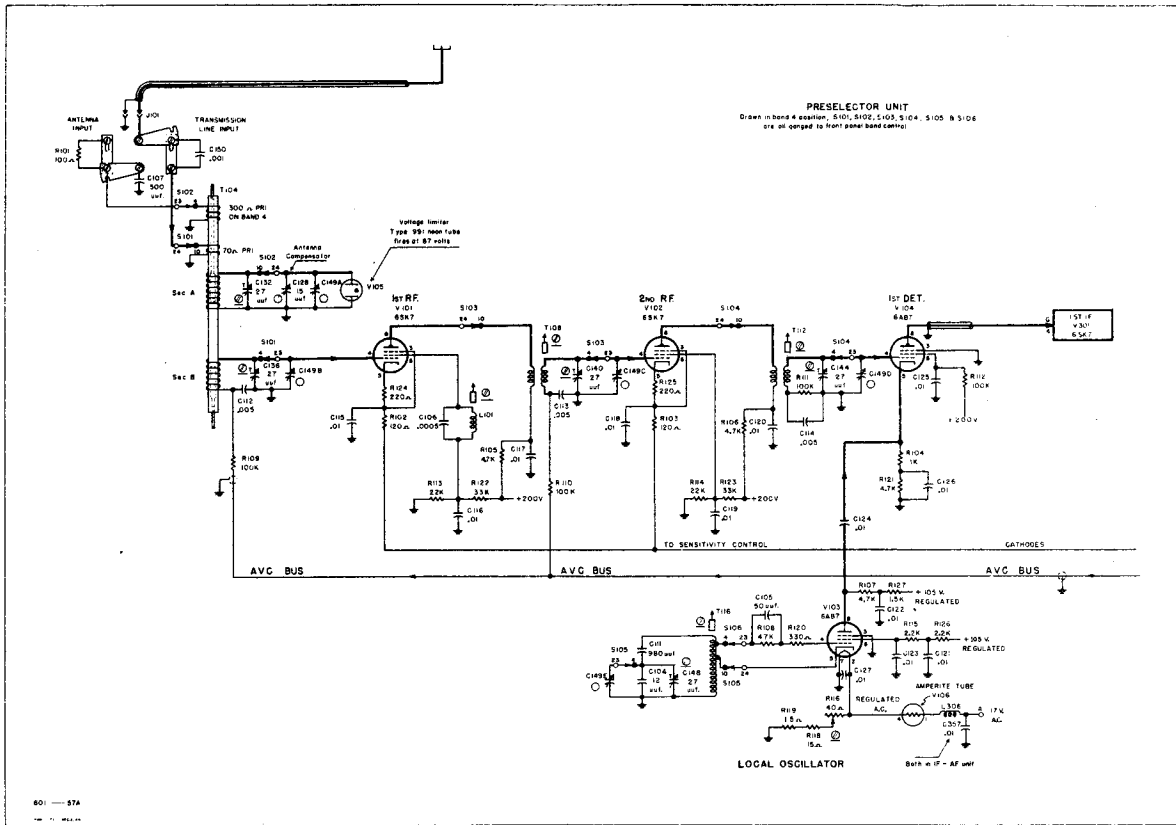
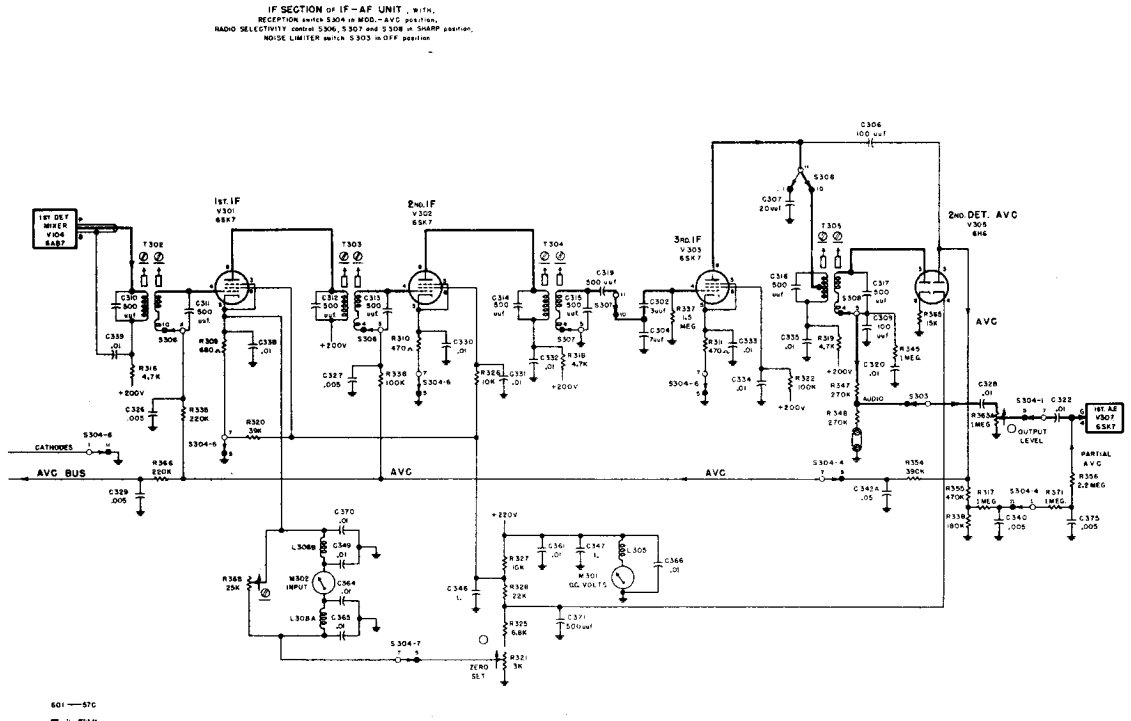
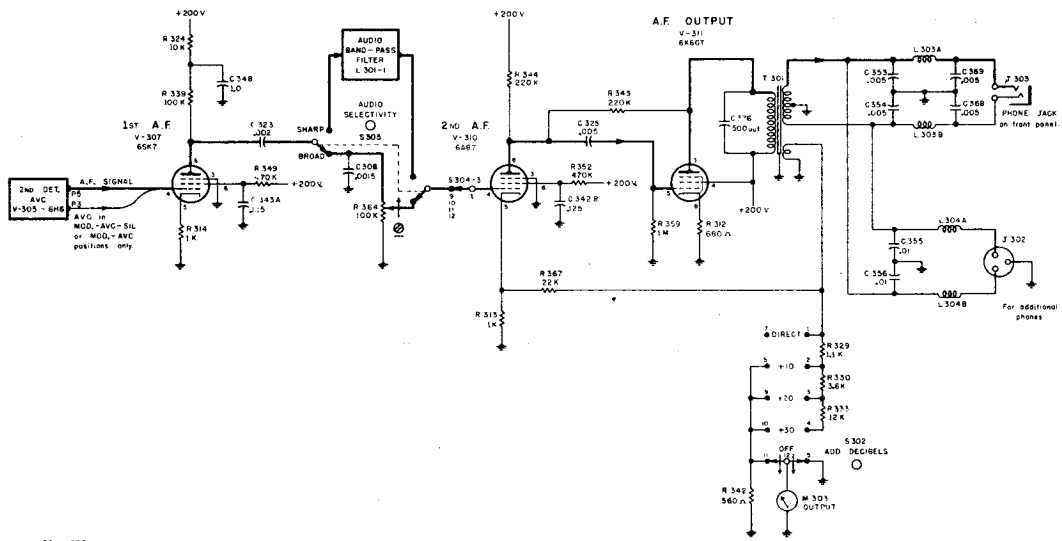

Fig. 57 RBB Receiver, simplified schematic, with IF Section drawn in



AUDIO SECTION OF I.F. - A.F. UNIT, WITH:  
 RECEPTION switch S304 in any position except CW-OL.



each of two positions of RECEPTION switch (CW and MOD-AVC positions).

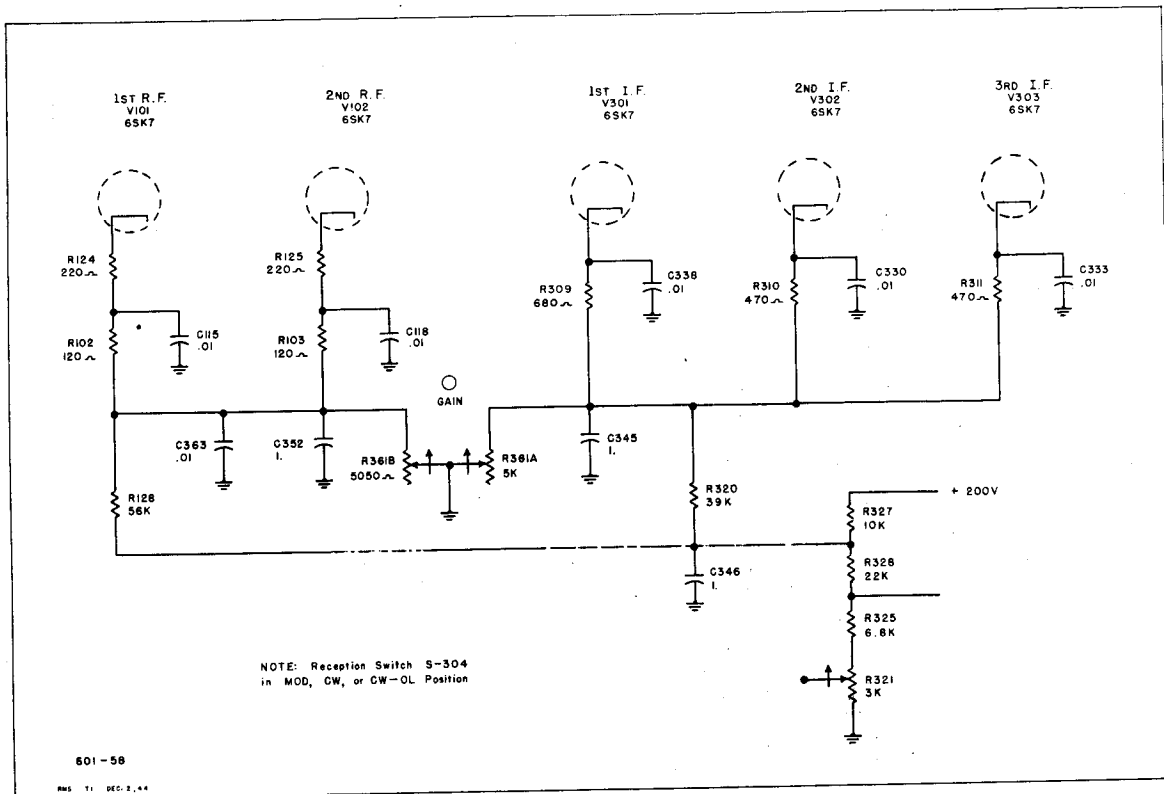
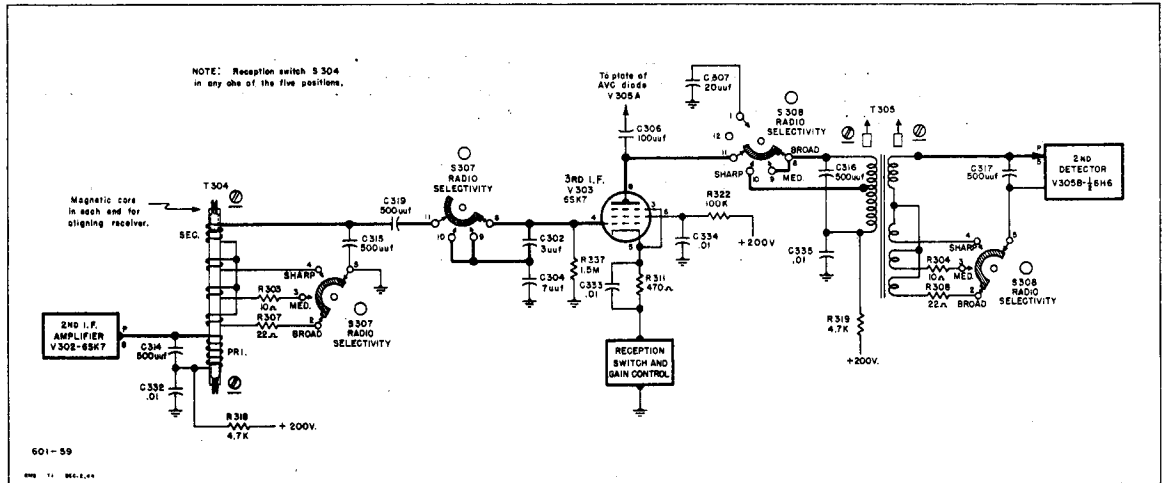

Fig. 58 REB GAIN control.

1. **PURPOSE:** To provide for manual control of the receiver gain to avoid overloading the RF and IF stages with strong incoming signals.
2. **GENERAL CIRCUIT CONDITIONS:** The gain of the RF and IF amplifiers is controlled by varying the cathode potentials, and consequently the bias.
3. **OPERATION:**
  - (a) R-361A and B are part of a bleeder network between ground and B+.
  - (1) Rotating R-361 so the potentials on the cathodes are more positive applies more fixed bias and causes a decrease in sensitivity.
4. **RESULTS:** The GAIN control permits the operator to adjust the receiver sensitivity to compensate for unusual values of signal strength and background noise. This provides better reception over a wider range of signal strength than would be possible with only automatic control.







- (3) This negative voltage is applied, through the filter R-354 and C-342A, to the control grids of the 1st and 2nd RF and the 1st and 2nd IF amplifiers.
- (4) The smaller negative voltage across only R-338 is applied to the control grid of the 1st AF amplifier as partial AVC.
- (5) The AVC voltage increases in amplitude with an increase in signal strength.

(c) Delay action:

- (1) The positive voltage across R-325 and R-321 is applied to the cathode of V-305A as delay bias, to prevent AVC action until the signal exceeds a predetermined level.

4. RESULTS:

- (a) AVC automatically regulates the output of the receiver according to the strength of the incoming signal. This helps to overcome the effects of fading, and prevents strong signals from blasting in while the receiver is being tuned.
- (b) The delay action permits the receiver to operate with maximum sensitivity for the reception of weak signals.

#### INPUT METER

1. PURPOSE: To provide a visual indication of the input signal strength to aid in tuning the receiver.
2. GENERAL CIRCUIT CONDITIONS: The input meter M-302 operates in the cathode circuit of the 1st IF stage, will deflect only when AVC action is taking place, and is calibrated in db above 1 microvolt.
3. OPERATION:
  - (a) Tune the receiver approximately to the desired signal.
  - (b) Detune from the signal to remove AVC action.
  - (c) Rotate ZERO SET control R-321 until the input meter reads zero. In this condition, the potential across the meter is balanced; the drop across R-309 equals the drop across the lower part of R-321.
  - (d) Retune to the signal. AVC voltage applied to the control grid of V-301 will allow less current to flow through V-301 and R-309.
  - (e) Less voltage drop across R-309 unbalances the voltage across the input meter, causing deflection. The stronger the incoming signal, the greater the deflection of the meter.
4. RESULTS: Maximum deflection of the input meter indicates that the receiver is tuned correctly to the incoming signal. The meter is more accurate than the ear.

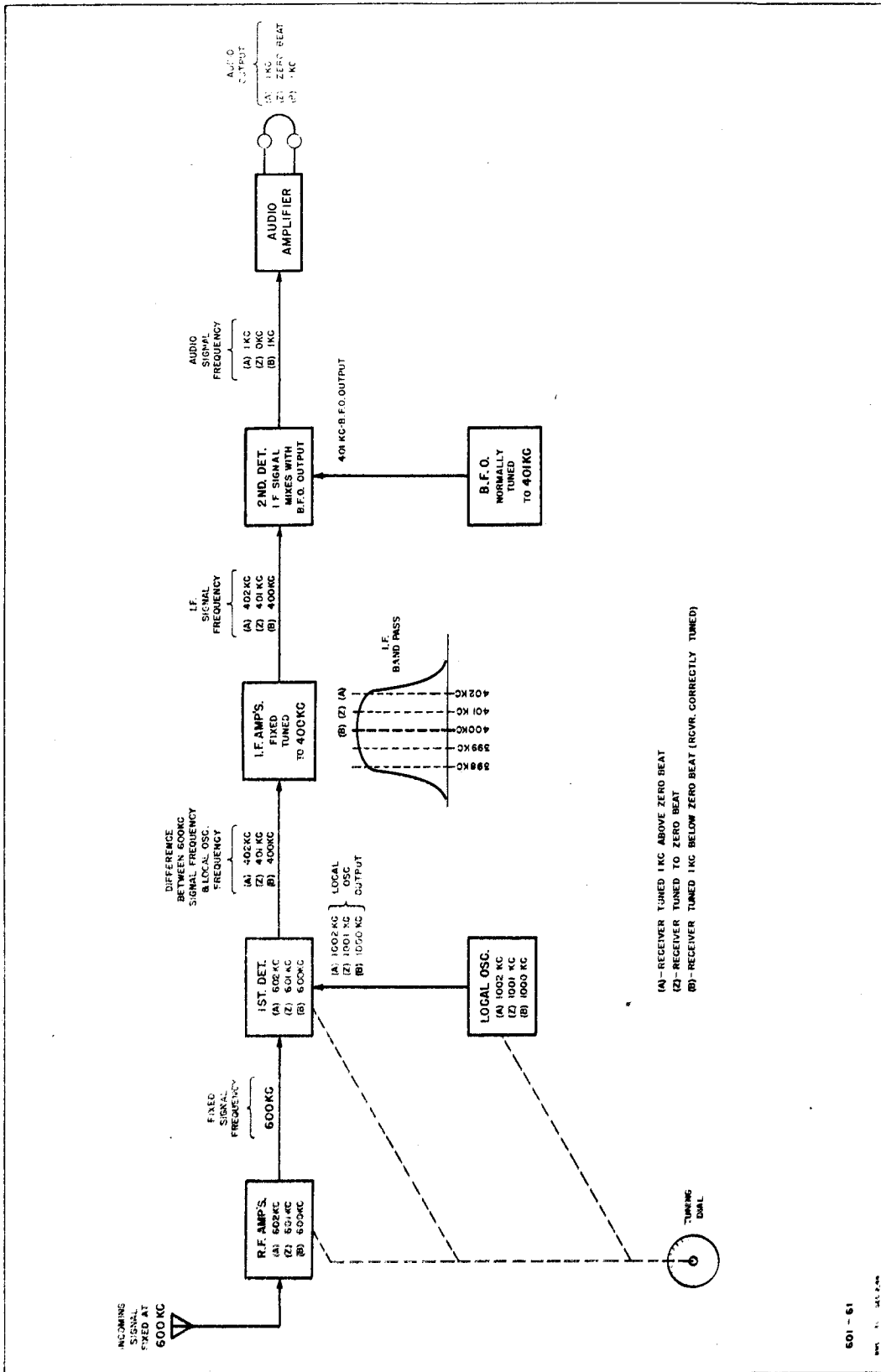

Fig. 61 B.F.O. or CW oscillator operation in RBB Receiver.

RECEIVERS  
GENERAL NOTES



## DC POWER DISTRIBUTION

### 1. GENERAL CIRCUIT CONDITIONS:

- (a) B- is operated below ground potential so amplified AVC may be used in this receiver.
- (b) The DC for all stages in the receiver with the exception of the AF output tube flows through R-158, R-147, R-148 and R-149.
- (c) The negative drop across R-148 and R-149 is applied to the cathode of the AVC tube.
- (d) The negative drop across part of R-158 is applied to the cathode of the output limiter tube.

### AMPLIFIED AVC (DELAYED)

1. **PURPOSE:** To hold the receiver output more nearly constant than is possible with simple AVC.

### 2. OPERATION:

- (a) The AVC tube must be biased at least to cutoff so it will act as a detector.
  - (1) The drop across R-147 provides the delay action by biasing the AVC tube beyond cutoff.
- (b) RF signal voltage is fed to the grid of the AVC tube through C-145.
- (c) Signal variations on the AVC grid cause variations in plate current through R-135, developing a negative voltage across it.
- (d) R-134, C-185 and C-170 filter the variations and allow a steady DC potential to be applied to the RF and 1st and 2nd IF stages as amplified AVC.

### OUTPUT LIMITER

1. **PURPOSE:** To limit peaks of audio signal and noise above a value determined by the setting of Limiter control R-158.

### 2. OPERATION:

- (a) The limiter tube must be conducting at all times to pass audio variations.
- (b) The setting of R-158 determines the amplitude of negative voltage on the cathode of the limiter.
- (c) Positive signal swings which exceed the value of negative voltage on the limiter cathode will cause the limiter tube to stop conducting, thus opening the audio line during high positive peaks of signal or noise.

3. **RESULTS:** Since this type of limiter affects only the positive peaks of signal, the action will not be as great as in a limiter which functions on both halves of the audio cycle. However, this circuit is effective in limiting high instantaneous peaks of noise.

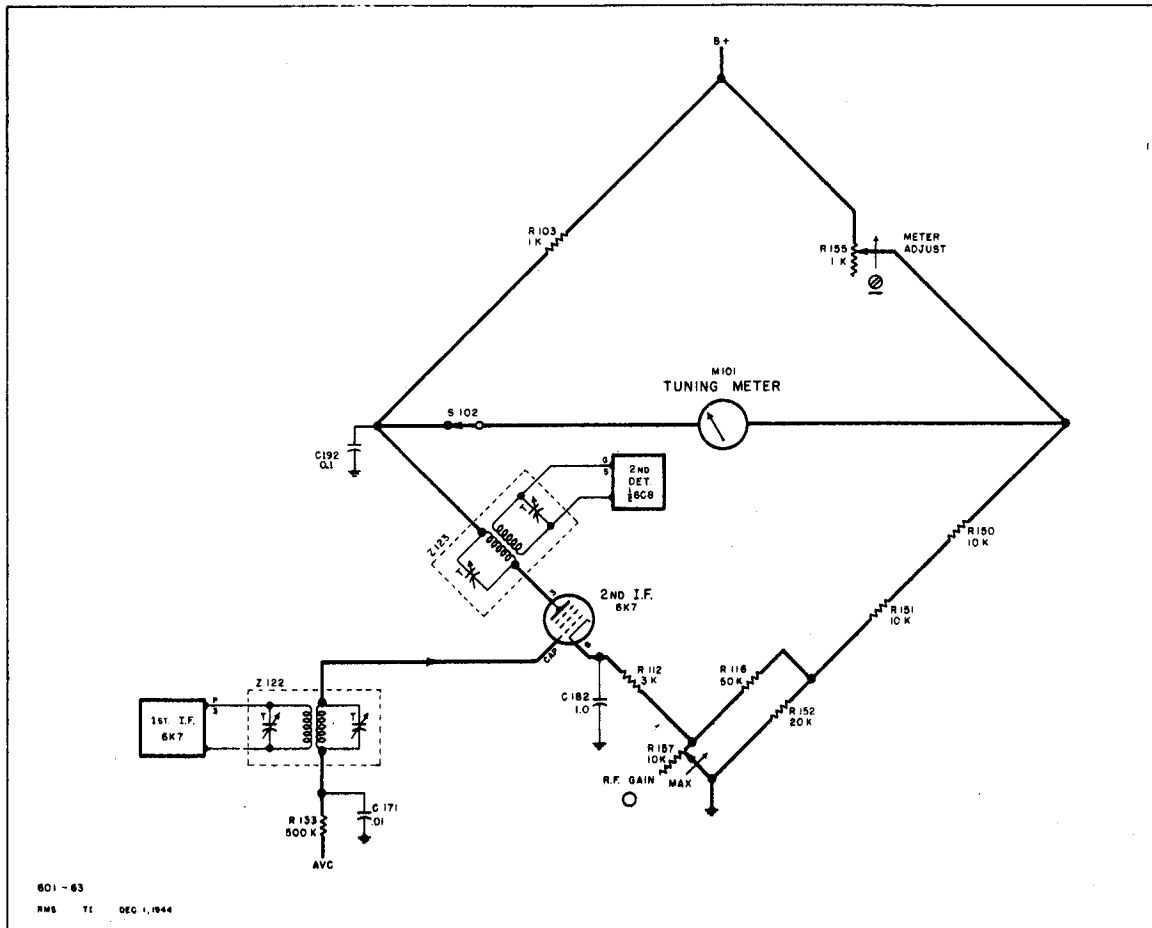
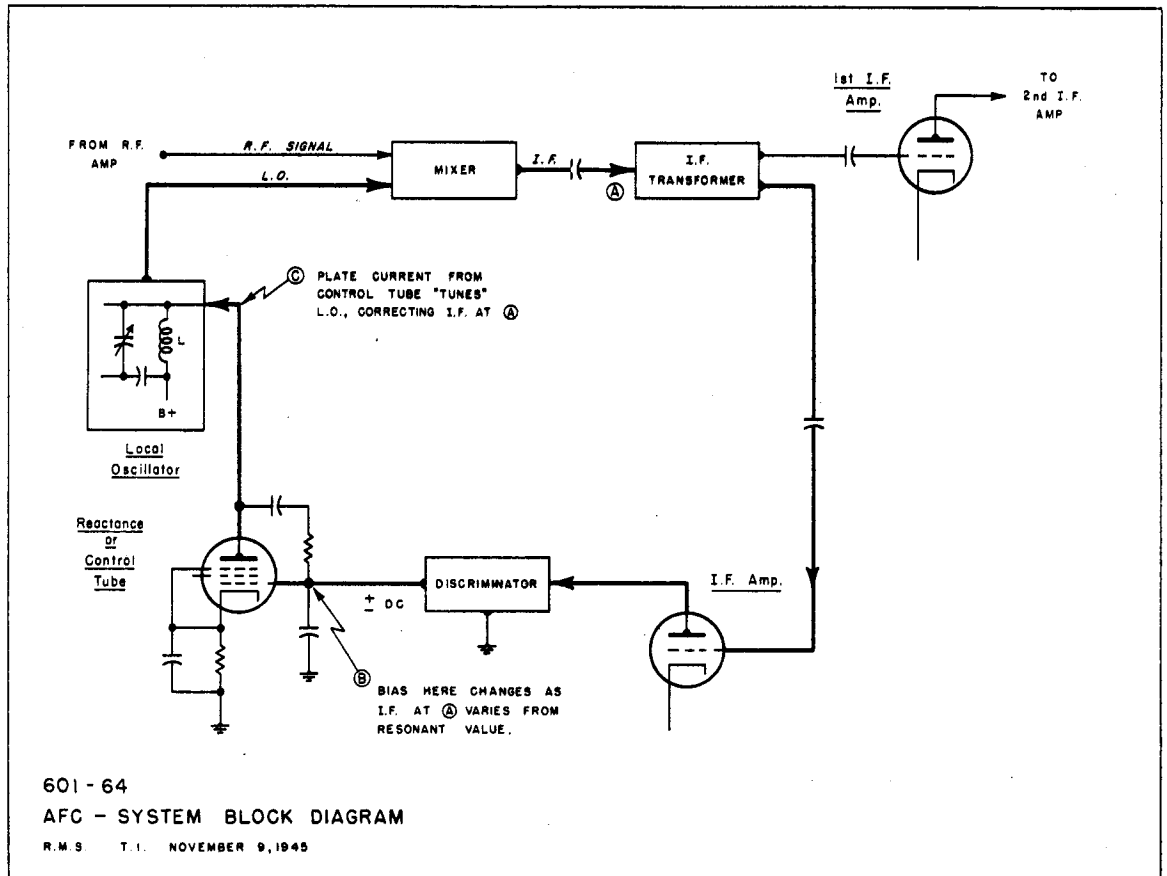

Fig. 63 RAO Receiver tuning meter.

1. **PURPOSE:** To provide a visual indication to aid in tuning the receiver.
2. **GENERAL CIRCUIT CONDITIONS:** AVC action must be operative, and the manual RF gain control rotated to the extreme clockwise position (maximum gain).
3. **OPERATION:**
  - (a) With the antenna connected, but the receiver not tuned to a signal, the screwdriver adjustment of R-155 is initially set so the potential across the bridge is balanced and the meter reading is zero.
  - (b) As the receiver is tuned to a signal, AVC action causes a reduction in current through the 2nd IF tube. The plate voltage of this stage increases, unbalancing the potential across the meter and causing it to deflect.
  - (c) The more nearly the receiver is tuned to the incoming signal, the greater the deflection of the tuning meter.
4. **RESULTS:** Maximum deflection of the tuning meter indicates that the receiver is tuned correctly. This method is more accurate than tuning by ear.



1. **PURPOSE:** In most selective superhetrodyne receivers, especially those employing AVC, it is quite difficult for the operator to tune the receiver to exactly the frequency of the incoming signal. Even with the receiver properly tuned there is apt to be a certain amount of drift of the local oscillator frequency due to line voltage fluctuations or temperature and humidity effects. The latter case is especially true at high frequencies. An automatic frequency control (AFC) system is used to correct these defects in tuning.
  
2. **COMPONENTS NECESSARY:** An AFC system must include a device capable of determining how much the IF varies above or below its proper value. This is called a discriminator. This device will produce a DC voltage output whose magnitude and polarity varies in accordance with the deviation of the IF signal from the resonant frequency of the IF stages. The DC voltage developed by the discriminator is used to vary the frequency of the local oscillator. This is done by using the DC voltage to vary the bias on the grid of a vacuum tube called a control or reactance tube. This reactance tube is connected into the local oscillator circuit such that when its plate current varies it will change the apparent inductance of the LC resonant circuit of the local oscillator. The amount that the apparent inductance of this circuit is varied is proportional to the magnitude and polarity of the DC voltage fed to the grid of the reactance tube. By this method it is possible to tune the local oscillator automatically in the direction which will correct the IF to its proper value. The block diagram below shows a typical AFC system.



## AUTOMATIC FREQUENCY CONTROL

**THE DISCRIMINATOR:** Below is shown a discriminator circuit which is commonly used in modern receiving sets employing AFC:

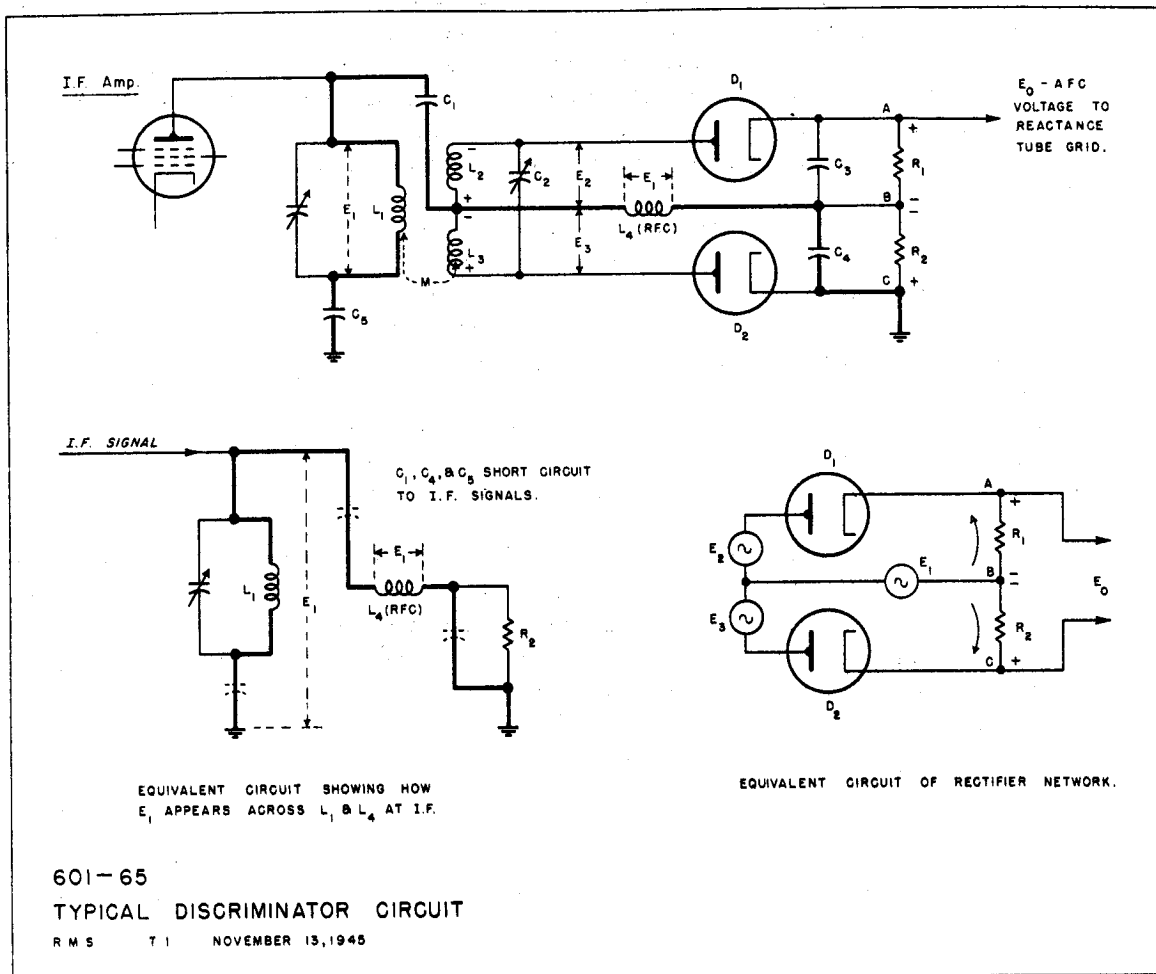

Consider first the transformer whose primary and secondary are tuned to the proper IF. The capacitors  $C_1$ ,  $C_4$  and  $C_5$  are large enough to offer a very low reactance path to IF signals. Therefore, the primary voltage,  $E_1$ , across  $L_1$ , is also present across the radio frequency choke,  $L_4$ . This is shown in the equivalent circuit above.

As a result of the mutual or inductive coupling between the primary and secondary, a voltage will be induced in the secondary coil  $L_2 + L_3$ . This will be designated as  $E_{ind}$ . The phase relation of this voltage with respect to the primary voltage  $E_1$ , will be essentially independent of the frequency.  $E_{ind}$  will cause a current  $I_s$ , to flow through the tuned circuit comprised of  $L_2 + L_3$ ,  $C_2$ , and the resistance present in the circuit. The secondary will appear as a resistive, inductive, or capacitive load to  $E_{ind}$  depending on the frequency of the voltage impressed across the primary.  $E_2$  and  $E_3$  will be 180 degrees out of phase with respect to the center tap of the transformer, and 90 degrees out of phase with the current  $I_s$ .

The rectifier network section will produce, through diode action, a positive DC voltage at A and C with respect to the center tap between  $R_1$  and  $R_2$ . This is shown in the equivalent circuit of the rectifier network.

$E_1$  and  $E_2$  will add together vectorily across the diode  $D_1$ , resulting in a DC voltage,  $E_{AB}$ , across  $R_1$ . In like manner  $E_1$  and  $E_3$  will add together vectorily and produce a DC voltage  $E_{CB}$  across  $R_2$ . The resultant of these two voltages will produce  $E_0$ , the DC output voltage of the discriminator.  $E_0$  is applied as a bias voltage to the grid of the reactance tube.

### ACTION OF DISCRIMINATOR AT RESONANT FREQUENCY:

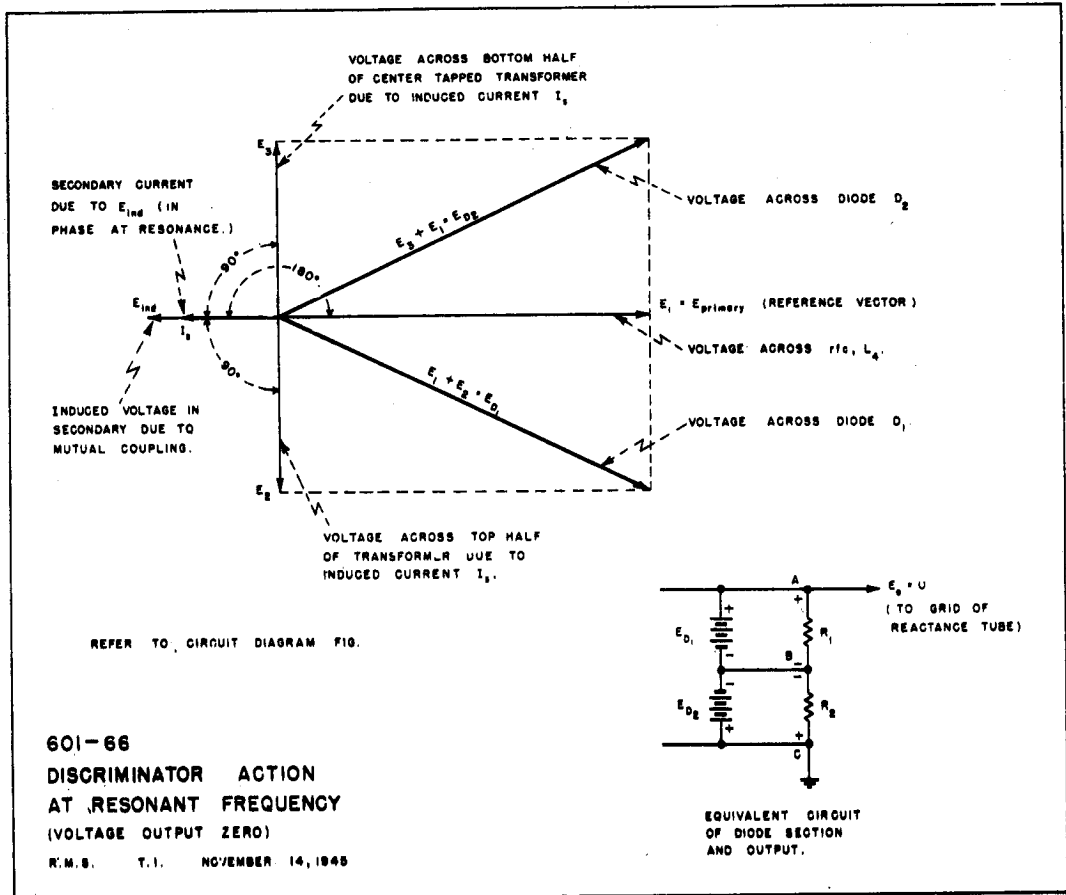

1. In all the vector diagrams in this discussion the resistive components (or vectors) have not been shown. The resistance in the circuit is a function of the 'Q' of the transformer as well as the effect of the rectifier network load. These factors control the amount  $I_s$  lags or leads  $E_{ind}$ . For this discussion some arbitrary value has been assumed in constructing the vector diagrams.

2. It will be assumed that there is a 180 degrees phase shift through the transformer.

3.  $E_1$ , the voltage across the primary or the RFC,  $L_4$ , will in all cases be used as the reference vector. The length of the vectors are arbitrary.

4. A study of the vector diagram above and the circuit diagram of Fig. 601-65 will reveal that the vector sum of  $E_1 + E_2$  is equal to  $E_1 + E_3$  in magnitude. Therefore DC voltage developed across  $R_1$  and  $R_2$  will be equal and opposite. The resultant AFC voltage,  $E_0$ , will be zero.

## AUTOMATIC FREQUENCY CONTROL

## ACTION OF THE DISCRIMINATOR ABOVE RESONANT FREQUENCY:

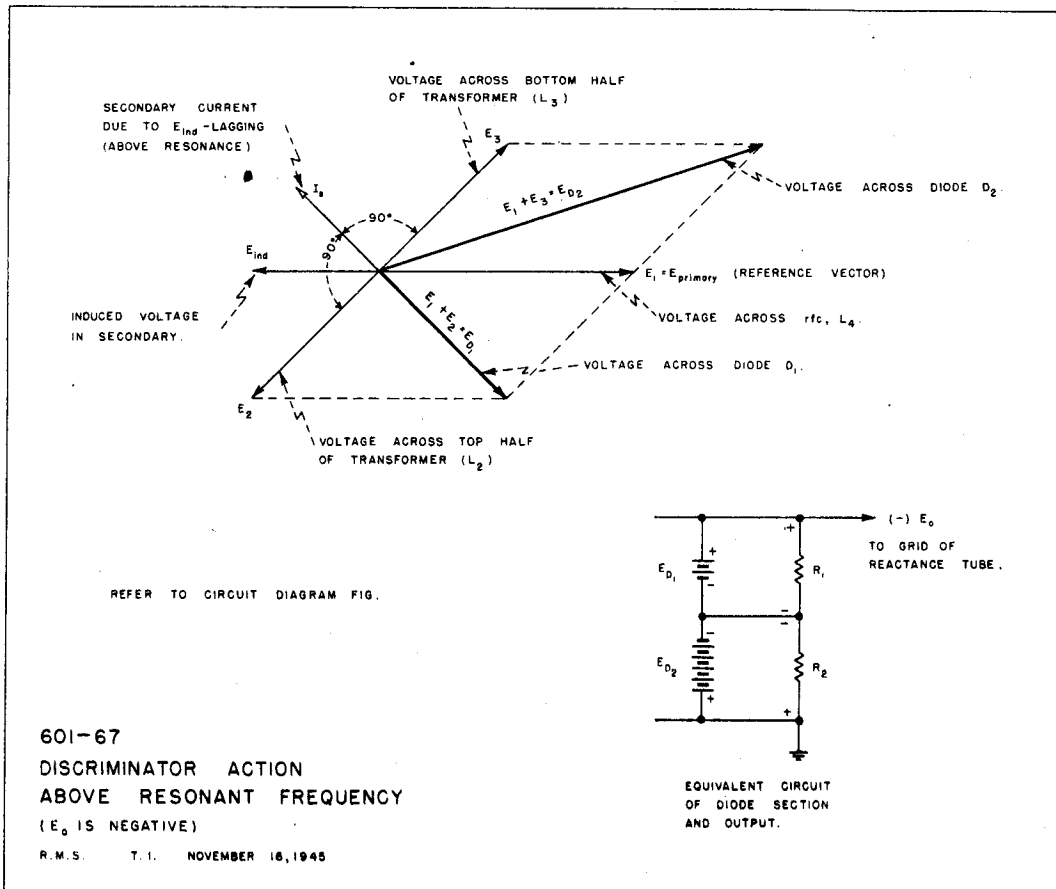

1. Comparing this diagram with Fig. 601-66 the change in the relative magnitudes of the vectors with change in frequency has not been shown. The primary purpose being to illustrate the phase shift of  $E_2$  and  $E_3$  with respect to  $E_1$ . Actually the more the IF differs from the resonant frequency the greater the output of the discriminator. The output varies from zero at resonant frequency to a maximum at the limits of the band pass characteristics of the circuit. Beyond these limits the output decreases very sharply and the AFC ceases to function. The range over which this system will function is also governed by the band pass characteristics of the stages preceding the discriminator. If more than one signal is present within the limits mentioned, the discriminator will select that signal which will produce the greatest output. This is dependent on the strength of the signal and the amount its frequency varies from the resonant frequency. The band pass characteristics of this circuit is primarily a function of the transformer design, and the reflected load of the rectifier network into the primary.

2. Above resonance the secondary of the transformer appears as an inductive load causing  $I_s$  to lag  $E_{ind}$ . The amount  $I_s$  lags depends upon the amount the IF differs from the resonant frequency. The voltage developed across the bottom diode  $E_{D2}$ , is greater than  $E_{D1}$ , the voltage across the top diode. Therefore, the DC voltage across  $R_2$  will exceed that across  $R_1$  and the resultant AFC voltage out will be negative with respect to ground.

## ACTION OF THE DISCRIMINATOR BELOW RESONANT FREQUENCY:

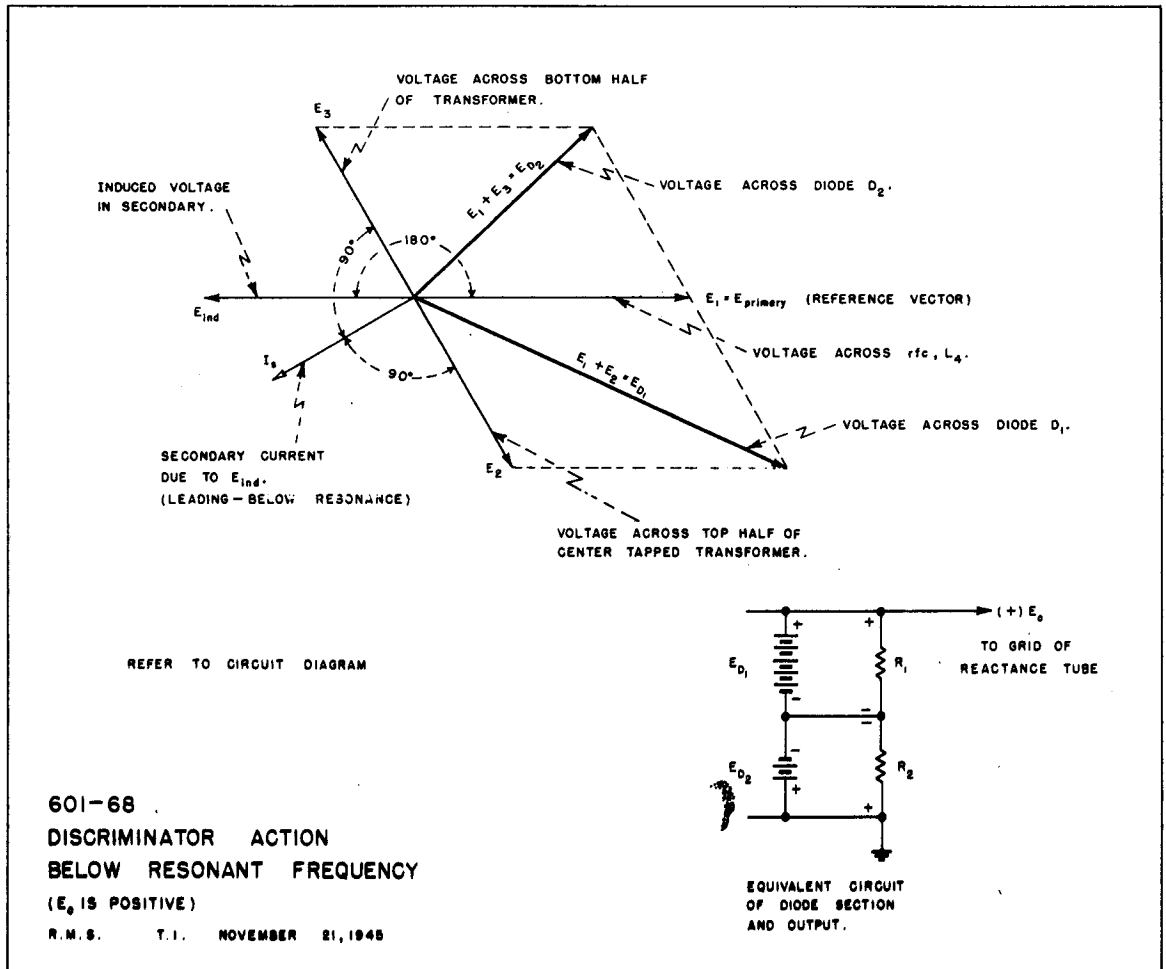

1. Below resonance the secondary of the transformer appears as a capacitive load causing  $I_s$  to lead  $E_{ind}$ . The amount which  $I_s$  leads  $E_{ind}$  depends upon the amount the IF is below the resonant value.
2. A study of the vector diagram will reveal that the summation of the voltages across the top diode is of greater magnitude than the summation of the voltages across the bottom diode.
3. Therefore, the voltage drop across  $R_1$  will be greater than across  $R_2$ , and the resultant AFC voltage  $E_o$  will be positive with respect to ground.

# AUTOMATIC FREQUENCY CONTROL

**REACTANCE TUBE:** Below is shown a circuit diagram of a typical reactance tube. The equivalent diagram shows only those elements which are important to the discussion of the action of the circuit.

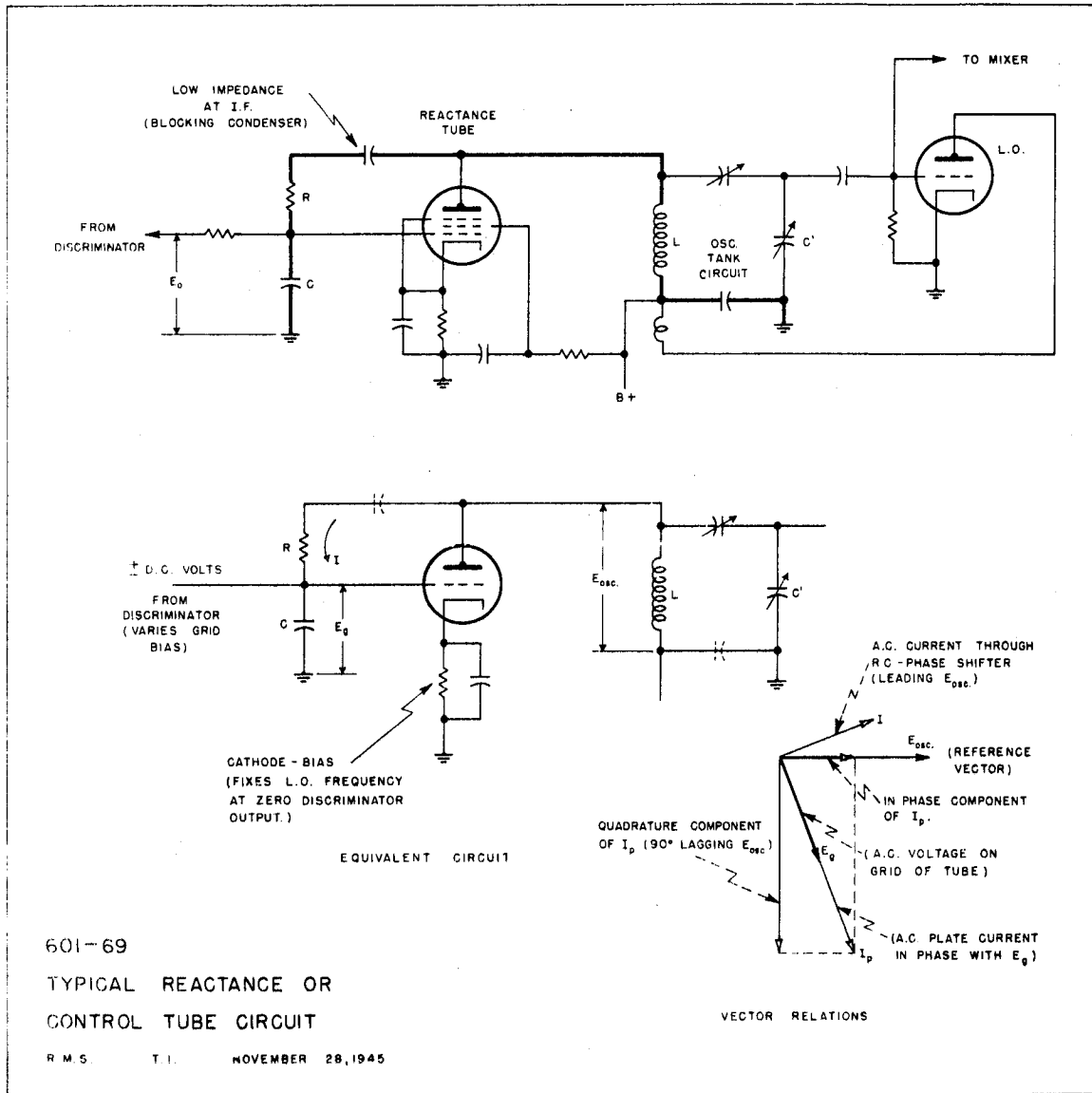

1. The frequency of the local oscillator is controlled primarily by the LC combination in its grid circuit. Neglecting other small factors which influence the resonant frequency, the formula that shows the relationship between  $L$ ,  $C$ , and the resonant frequency  $f_r$  is

$$f_r = 1/2\pi \sqrt{LC}$$

2. Any variation in the inductance,  $L$ , will change the resonant frequency. Based on the fact that the current through an inductance lags the voltage across the inductance, it is possible to produce the effect of changing the inductance of the coil by passing a lagging current through it.

3. In the oscillating state an AC voltage  $E_{osc}$ , is built up across the oscillator tank circuit as indicated in the equivalent circuit of Fig. 601-69. Referring to the vector diagram,  $E_{osc}$  will be used as the reference vector.
4.  $E_{osc}$  causes a current  $I$  to flow through the branch including  $R$  and  $C$ .  $R$  is made large compared to the capacitive reactance composed of  $C$  and the grid to cathode capacitance,  $C_{gk}$ , of the tube. Therefore,  $I$  will lead  $E_{osc}$  by a few degrees as indicated in the vector diagram.
5. The AC voltage,  $E_g$ , developed across  $C$  by  $I$ , will lag  $I$  by 90 degrees.
6. This AC voltage from grid to cathode will cause an AC plate current to flow which is in phase with this grid voltage  $E_g$  and is represented by the vector  $I_p$ .
7. This plate current can be split into two components, one in phase with  $E_{osc}$ , and the other 90 degrees lagging  $E_{osc}$ . The magnitude of this plate current is governed by the mutual conductance of the tube and will vary with the grid bias on the tube. This requires the proper self-biasing of the tube to operate on the lower curved portion of the  $e_c-i_b$  characteristic curve. Hence, the in-phase component and the quadrature component will also vary with the grid bias voltage.
8. This plate current flows through the inductance of the oscillator circuit and therefore the tube may be considered in parallel with the oscillator tank circuit.
9. The in-phase component of  $I_p$  is equivalent to a resistor across the inductance of the tank circuit of the oscillator. That is, a resistor placed across the coil would draw the same type (in-phase) of current through the coil. Therefore, the reactance tube tends to load the oscillator circuit and the load will vary with the grid bias on the tube.
10. The 90 degree lagging component draws the same type of current through the coil of the oscillator as a pure inductance would draw if placed across the coil. Hence, the reactance tube can be considered also as an inductance in parallel with the oscillator coil. The value of this apparent parallel inductance will vary with the bias voltage on the grid of the tube.
11. By connecting the output of the discriminator to the grid of this reactance tube, the grid bias will vary in accordance with the DC AFC voltage output of the discriminator. The magnitude of the plate current,  $I_p$ , will vary accordingly. Hence, the value of the apparent inductance in the oscillator tank circuit will change with the change in the discriminator output. This change will be in such a direction as to correct the local oscillator frequency to the proper value.
12. The reactance tube is always present across the tank coil so that a certain value of inductance is present as determined by the cathode bias when the AFC voltage is zero. Then when an AFC voltage is developed, the apparent inductance increases or decreases above or below this zero-voltage-value depending upon the magnitude and polarity of the AFC voltage.

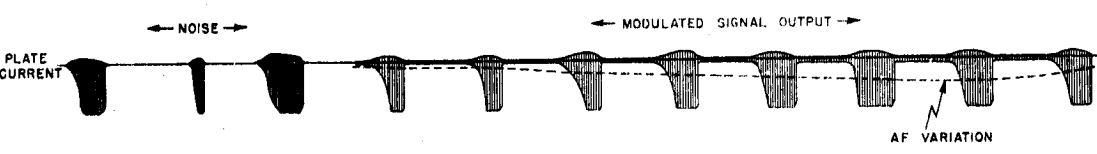
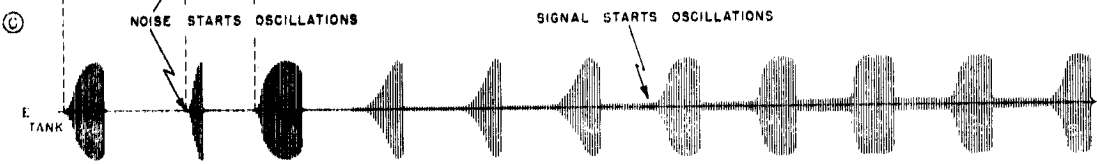
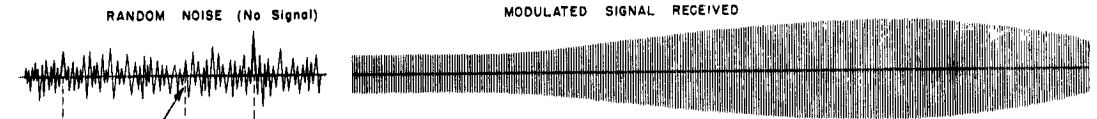
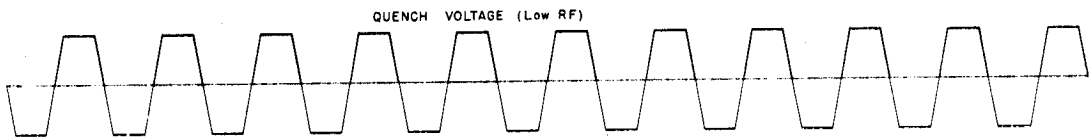
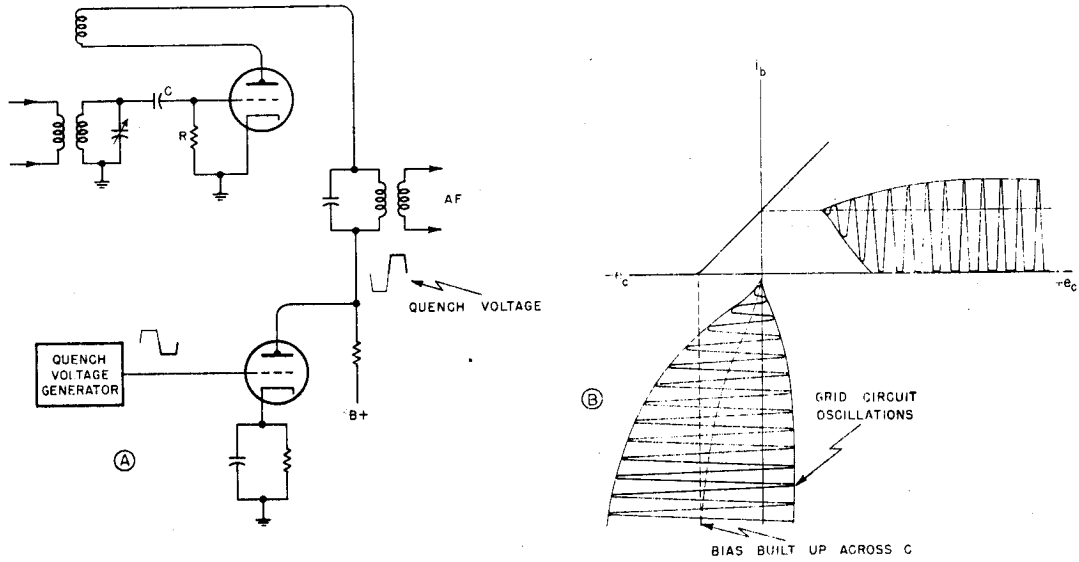

601-70  
**SUPER-REGENERATIVE DETECTOR**  
 R.M.S. T. JANUARY 15, 1946



**PURPOSE:** A detector which has extremely high gain characteristics for the reception of MODULATED RF signals usually in the VHF range.

**SENSITIVITY:** Extremely high.

**SELECTIVITY:** Poor, due to the large number of side-band frequency components present.

**FIDELITY:** Poor. Due to the 'quenching' action and the non-linear detecting characteristics, there is considerable audio distortion in addition to the amplification of background noise. This type of detector is limited primarily to speech modulated signals.

**OPERATION:**

(1) In a super-regenerative detector the regenerative coupling between the plate and the grid circuits of the tube is great enough so that self-sustained oscillations can be produced. However, these oscillations are periodically quenched by applying to the circuit an alternating voltage having a frequency much lower than that of the oscillations. A sine wave or square wave can be used for this quenching voltage or by the proper choice of circuit elements it is possible to produce a self-quenching circuit. In all cases the circuit must be properly adjusted for optimum quench frequency and quench voltage in order to obtain the high gain possible from a regenerative circuit. The build-up of oscillations are initiated by any signal present in the grid circuit. The rate at which oscillations build up is a function of the amplitude of the initiating signal. By utilizing this property it is possible to reproduce in the output of the detector a voltage which will vary approximately in accordance with the amplitude of the modulations of the received signal. The three important methods of operation are: one, allowing the oscillations to build up to a maximum before quenching; two, quenching before maximum is reached; and three, self-quenching.

(2) In Fig. 601-70(A) a typical super-regenerative detector circuit is shown in which a square wave voltage varies the plate supply above and below the critical oscillation point which starts and stops the oscillations periodically at a low RF rate, such as 25KC. An example of how oscillations might build up in the grid circuit during the positive cycle of the quench voltage is illustrated in Fig. 601-70(B). Oscillations will start only during the positive half of each quench voltage cycle and then only from some initiating pulse or signal present in the grid circuit.

(3) No Signal Present: During the condition when no RF carrier signal is being received, the build up of oscillations is started by any thermal agitation, shot effect, or random noise voltage present in the circuit. As illustrated in the wave forms of Fig. 601-70(C), oscillations start at irregular times during the positive cycles of the quench voltage. The size of the initiating voltage (noise voltage in this case) and the time during the positive half cycle at which it occurs, determines how fast and at what value oscillations build up in the grid tank circuit. As these voltages occur at random, the amount of plate current will vary in rough proportion resulting in a hissing noise in the output of the receiver. This random effect is illustrated in Fig. 601-70(C). It can be seen that the average plate current which is a function of the area beneath the envelope of the RF current oscillations, will vary at random when oscillations are initiated by noise pulses.

## SUPER-REGENERATIVE DETECTOR

(4) **Modulated RF Signal Present:** When the RF signal has a greater amplitude than the random noise signal, it then becomes the initiating pulse and the noise or hiss present is suppressed to some extent. The starting of the oscillation and the rate at which they build up is a function of the amplitude of the initiating pulse or in this case the amplitude of the modulated signal present. Referring to the curves drawn in Fig. 601-70(C), the area beneath the envelope of the oscillating plate current during each positive pulse of the quench voltage is roughly proportional to the amplitude of the modulated RF signal at that instant. Hence the AF developed is roughly a reproduction of the modulations of the original RF signal.

**MISCELLANEOUS DATA AND LIMITATIONS:**

(1) The use of a separate oscillator for quenching purposes may be eliminated if the grid leak resistor is increased to a size that will result in intermittent oscillations. The size of the grid resistor should be such that the quench frequency will be far above the audible frequency range. Such a detector is called a self-quenched super-regenerative detector. The theory of operation for this detector is slightly different than that for a separately quenched super-regenerative detector in that the strength of the received carrier helps to determine the quench frequency, and the variation in this frequency caused by the modulation changes in carrier strength, results in an audio output from the detector.

(2) All super-regenerative circuits are characterized by higher sensitivity for weak signals than for strong ones. The ever present hiss in the output makes its use impractical for broadcast use, but this type of detector has a tendency to suppress external noise peaks. Also the circuit coupled to an antenna will radiate, causing undesired interference. It is useful for the amplification of VHF where ordinary methods of amplification cannot be employed.