

# SECTION V

## SIGNAL CONTROL PANELS

### CRV-50099, 50120, and 50157

#### TECHNICAL SUMMARY

##### ELECTRICAL CHARACTERISTICS—

###### Meters:

Receiver Output Current (d-c) .....	0 to 1.5 ma
Line Level (1 milliwatt in 600 ohms) .....	-20 db to +6 db

###### AGC Time Constant (seconds):

	Fast	Medium	Slow
Telegraph (using Tone Keyer) .....	0.01	0.1	1.0
Telephone (using Audio-Frequency Amplifier) .....	0.02	0.2	—

##### MECHANICAL SPECIFICATIONS—

###### Dimensions:

Panel Size .....	19 inches (width) x 10 <sup>1</sup> / <sub>2</sub> inches (height)
Unit Depth .....	5 <sup>7</sup> / <sub>8</sub> inches
Weight (net) .....	17 pounds

#### DESCRIPTION

The signal control panel of the diversity receiving system is the unit common to all three receivers where the respective output signals are combined and the resulting output switched to a tone keyer or audio-frequency amplifier unit as required. The design of this panel is such as to permit switching and monitoring of the three receivers either singly or in diversity combination on either telegraph or telephone service.

In a dual group equipment there are slight differences in the internal connections of the respective signal control panels. In such an equipment the signal control panel in receiver bay number two is wired to permit the output from any or all receivers in the left-hand group to be switched to the tone keyer for that group (Keyer "A") or to the auxiliary tone keyer (Keyer "C"). The signal control panel in receiver bay number five is wired to permit the output from any or all receivers in the right-hand group to be switched to the tone keyer for that group (Keyer "B") or to the auxiliary tone keyer (Keyer "C"). The cross switching thus provided enables the output from any receiver or receivers in either or both groups to be connected to the auxiliary tone keyer (Keyer "C").

The diode output of each associated receiver passes through a milliammeter and then to switches which are used to transfer the rectified output of that receiver to any one of from one to four auxiliary units, such as tone keyer or audio-frequency amplifier units. These switches at the same time feed the AGC bias supply from the selected tone keyer or audio-frequency amplifier unit to the controlled radio-frequency am-

plifier stages of the receiver. Separate time-constant switches are provided on the panel for the AGC supply voltages used.

A multiplicity of switches and jacks permits the monitoring of any audio-frequency amplifier output, tone keyer output, or intermediate-frequency amplifier (diode) output signal. The monitoring switches are electrically interlocked to prevent interconnection of two output circuits either accidentally or by improper manipulation.

The combined rectified output of two or three receivers being used in diversity combination may be observed on the fourth milliammeter, which may be switched into the input circuit of whichever tone keyer or audio-frequency amplifier unit is in use. An output meter also is provided on the panel to indicate the level of the outgoing signal.

In a dual group equipment the level of the signal at the output terminals of keyers "A" or "C" may be checked on the volume indicating meter which is mounted on the signal control panel located in receiver bay number two; that for keyers "B" and "C" may be checked at the signal control panel located in receiver bay number five.

Output jacks for all tone keyer output, audio-frequency amplifier output, and intermediate-frequency monitor signals are provided. There are also jacks for outgoing lines, pilot or signaling lights, and switches. The arrangement and electrical connections of these jacks, lights, and switches is generally determined by local requirements.

## OPERATION

The arrangement of the signal control panel depends upon the type of transmission being received and upon the number of receivers actively employed. General instructions for the diversity arrangement of receivers are included in Section I which describes the operation of the system as a whole. The various alternative forms of operation permitted by this panel are described in the following paragraphs.

It will be observed that the major portion of the panel, starting at the left, is arranged in four vertical rows, each containing a milliammeter and two key switches. The first three rows correspond to the three individual receivers, while the fourth is employed for the diversity combination of any two or all three. Individual and combined outputs are indicated by the milliammeters and each pair of key switches enables selection of the desired tone keyer or audio-frequency amplifier unit.

When the receivers are to be used singly, the switches in the fourth or "COMBINED" row must be left in the central (open) position. Conversely, for diversity combination, these switches must correspond in position with those of the preceding rows affected. Thus, with the two tone keyer units and one audio-frequency amplifier unit in a single group assembly it is possible to obtain the following conditions of operation:

(a) Three receivers in diversity on a telephone or telegraph signal.

(b) Any two receivers in diversity on one telephone or telegraph signal and the third receiver singly on a different telephone or telegraph signal.

In a dual group equipment which contains three tone keyer units and two audio-frequency amplifier units it is possible to obtain the following arrangements of receivers in diversity:

(a) Two groups of three receivers, each group on a different telephone or telegraph signal.

(b) Three groups of two receivers, each group on a different telegraph signal.

(c) Two groups of two receivers, each group on a different telephone or telegraph signal and one group of two receivers on a telegraph or telephone signal.

Between the third and fourth rows of key switches is an additional row of four rotary switches for adjustment of the AGC time constant. Each switch has three positions which afford the selection of speeds shown in the "Technical Summary". Proper use of these speeds is indicated in Section I.

The output meter at the extreme right-hand side of the panel is calibrated in decibels (db) over a range which extends from -20 db to +6 db. This meter is designed for connection across a 600 ohm line and is adjusted to indicate zero when a potential of 1.9 volts r. m. s. (sine wave) is connected across its terminals. The reference level of zero db is based upon a power of 2.5 milliwatts in a 600 ohm line. This instrument therefore indicates line levels (in decibels) above or below the established reference level. Actual level indications required for use over the lines which connect this equipment to other equipments are the determining factor in correct operation.

## SERVICE

In general, little or no trouble is to be expected during the service life of the signal control panel. The only troubles that can develop are damaged meters, faulty contacts in switches or jacks and leakage in the AGC time-constant capacitors or associated wiring switches. Ordinarily, the fault is easily located. Where trouble develops in the AGC system, the fault can generally be located by a process of elimination, trying various combinations obtainable with the switches below the milliammeters. Leakage resistance of capacitors may be checked with a megger and should be at least 100 megohms for a 1-mfd. unit and at least 1,000 megohms for a 0.1-mfd. unit.

Complete loss of AGC action on any one receiver of a diversity group is generally due to defective switch contacts on the signal control panel or to a ground in the bias circuit of the r-f amplifier unit. In the former case, the receiver in trouble will receive no AGC bias, but will not affect other receivers with which it may be switched to the diversity combination. In the second case, switching the defective receiver in the diversity combination with another that is functioning normally will spoil the AGC action of both.

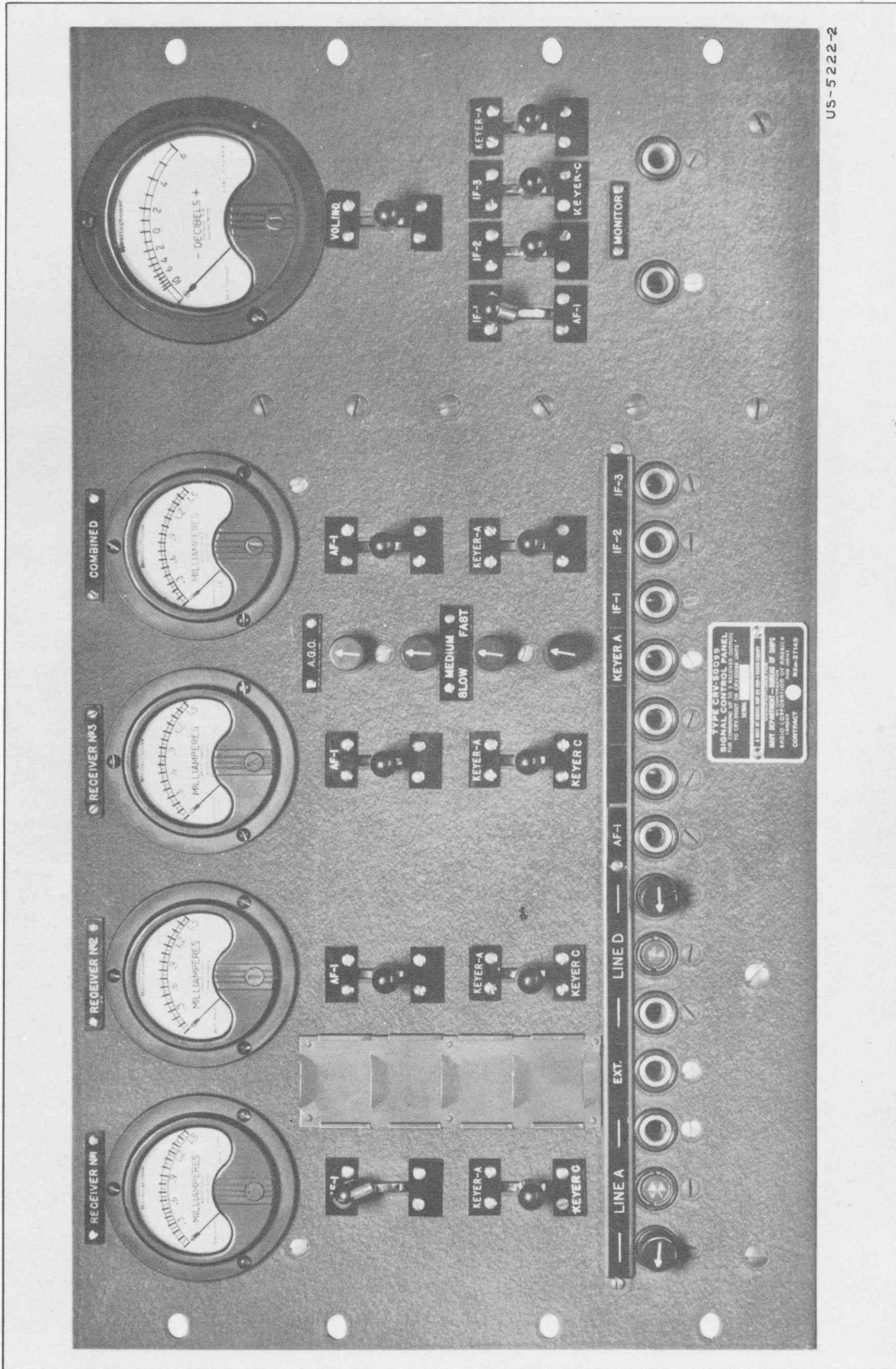

US-5222-2

Figure 1—Type CRV-50099 Signal Control Panel (Front View)

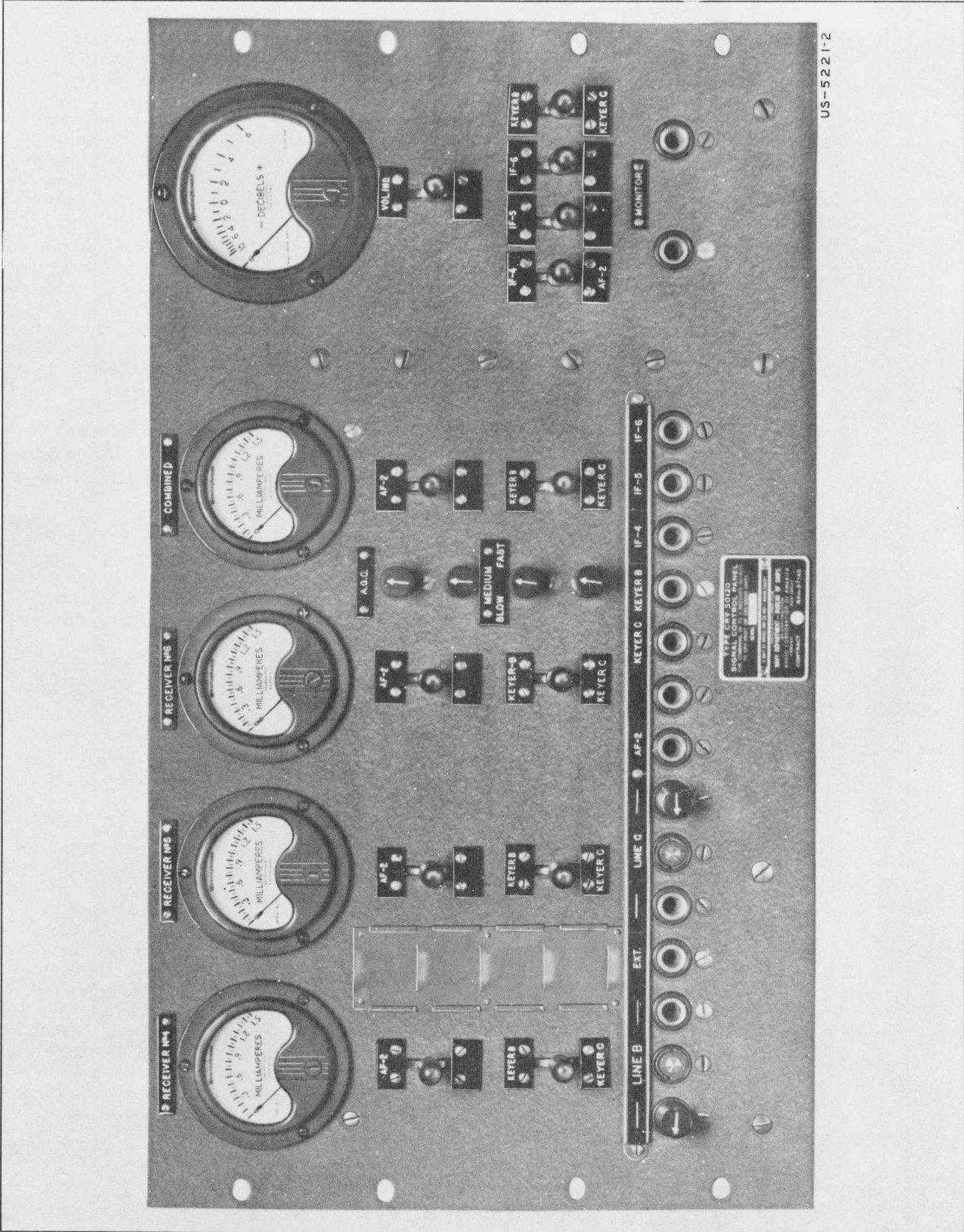

US-5221-2

Figure 2—Type CRV-50120 Signal Control Panel (Front View)



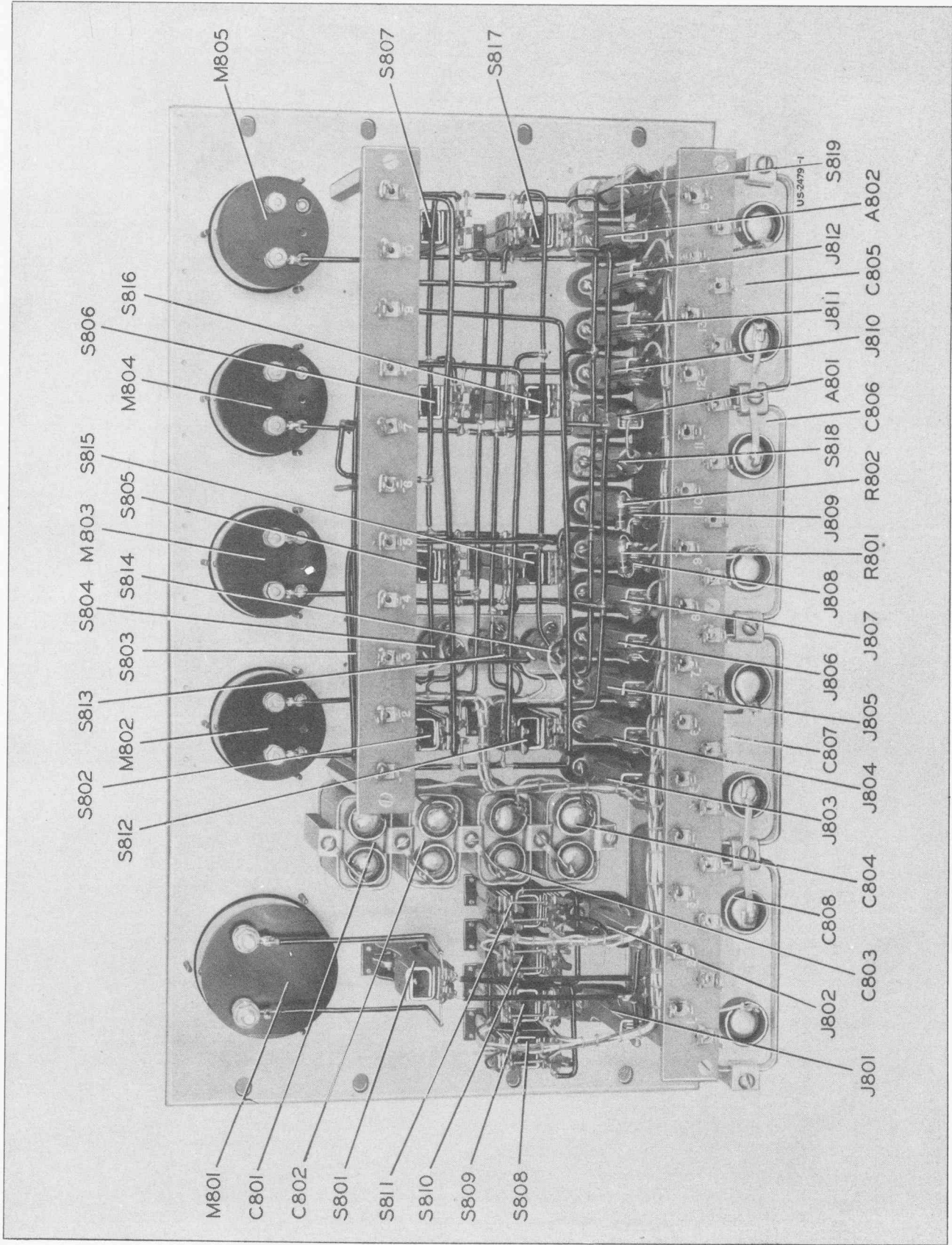

Figure 4—Signal Control Panel (Rear View)

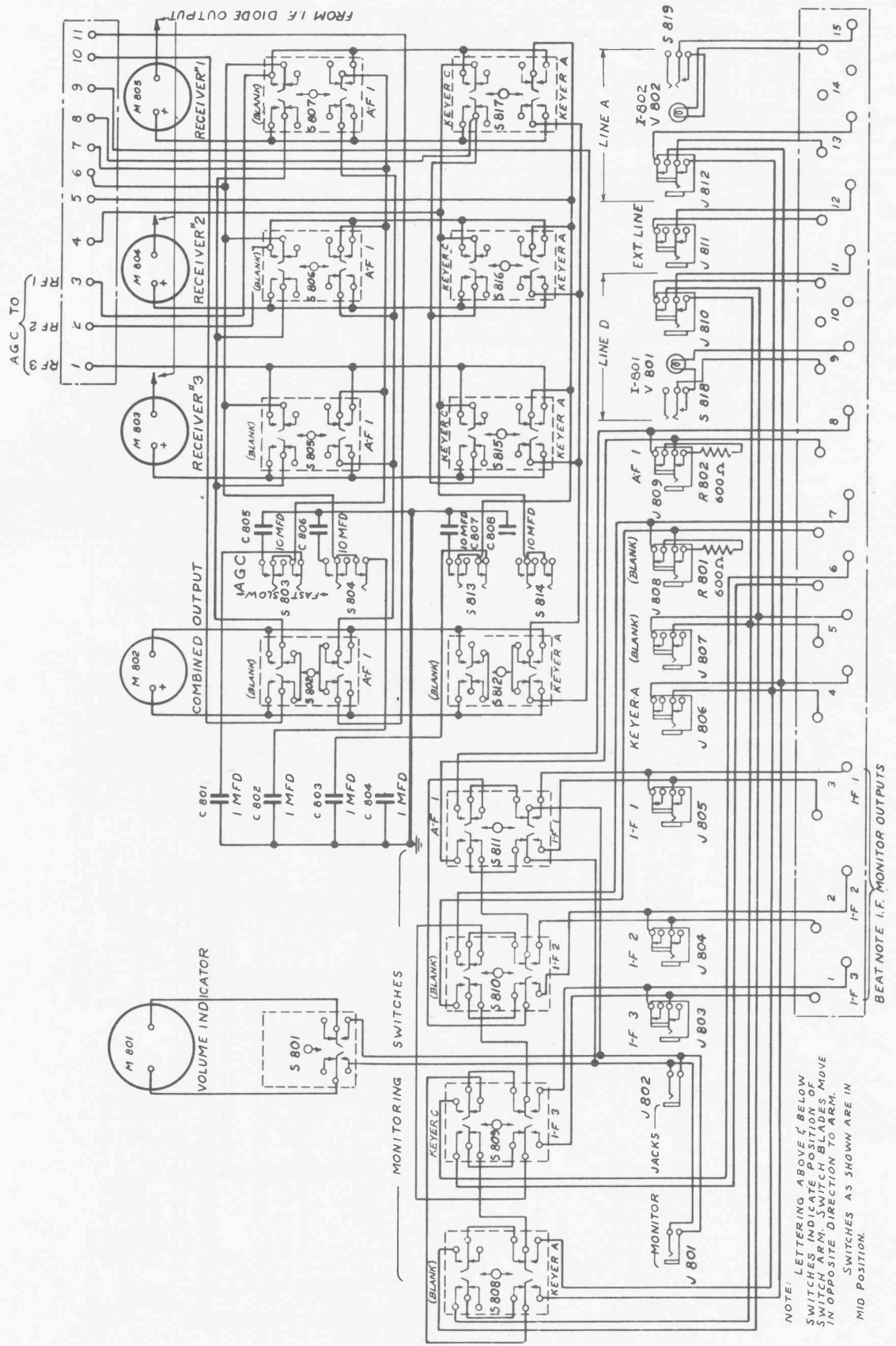

Figure 5—Type CRV-50099 Signal Control Panel Schematic (P-721905—Sub. 2)

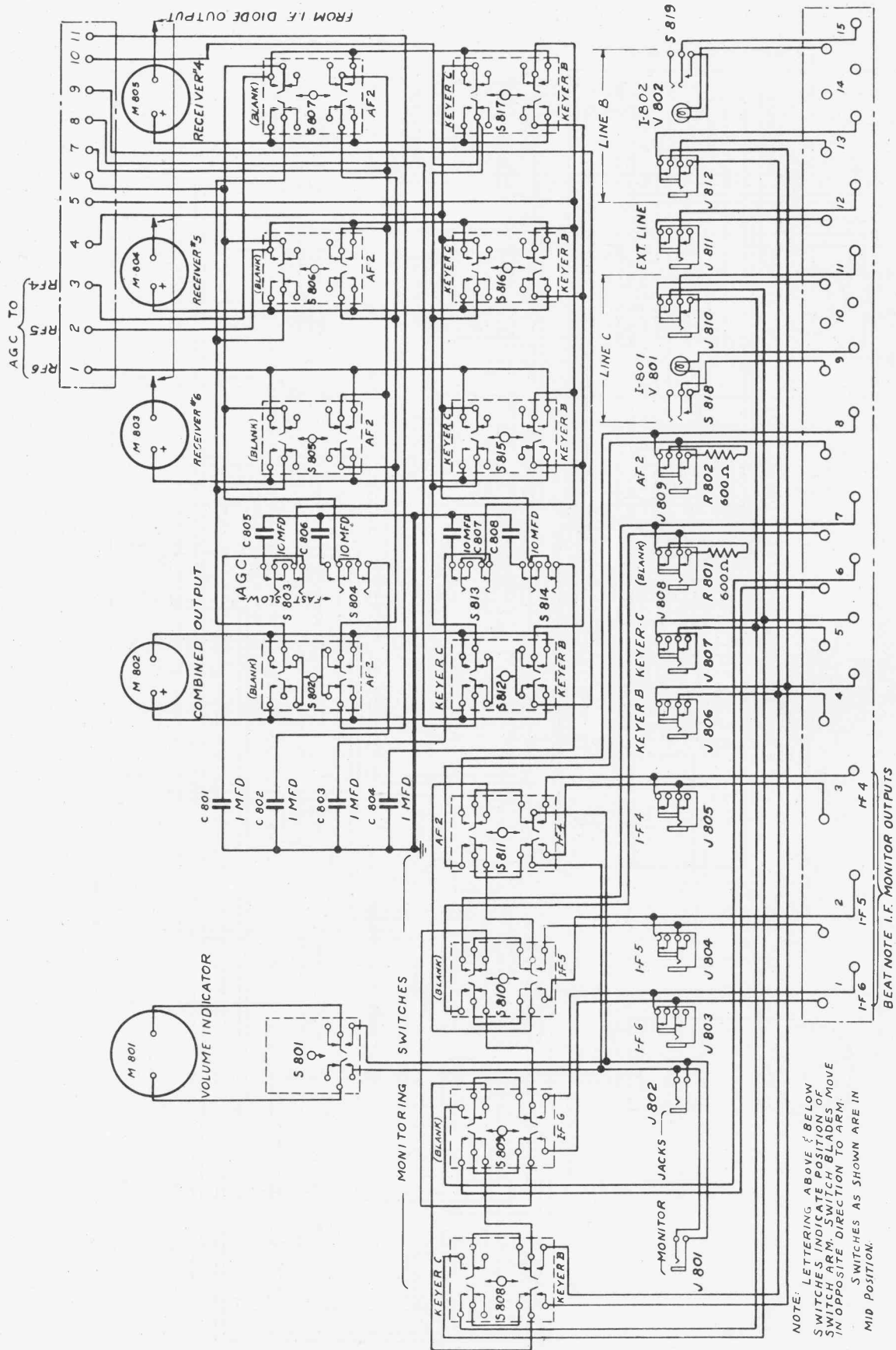

Figure 6—Type CRV-50120 Signal Control Panel Schematic (P-721906—Sub. 3)



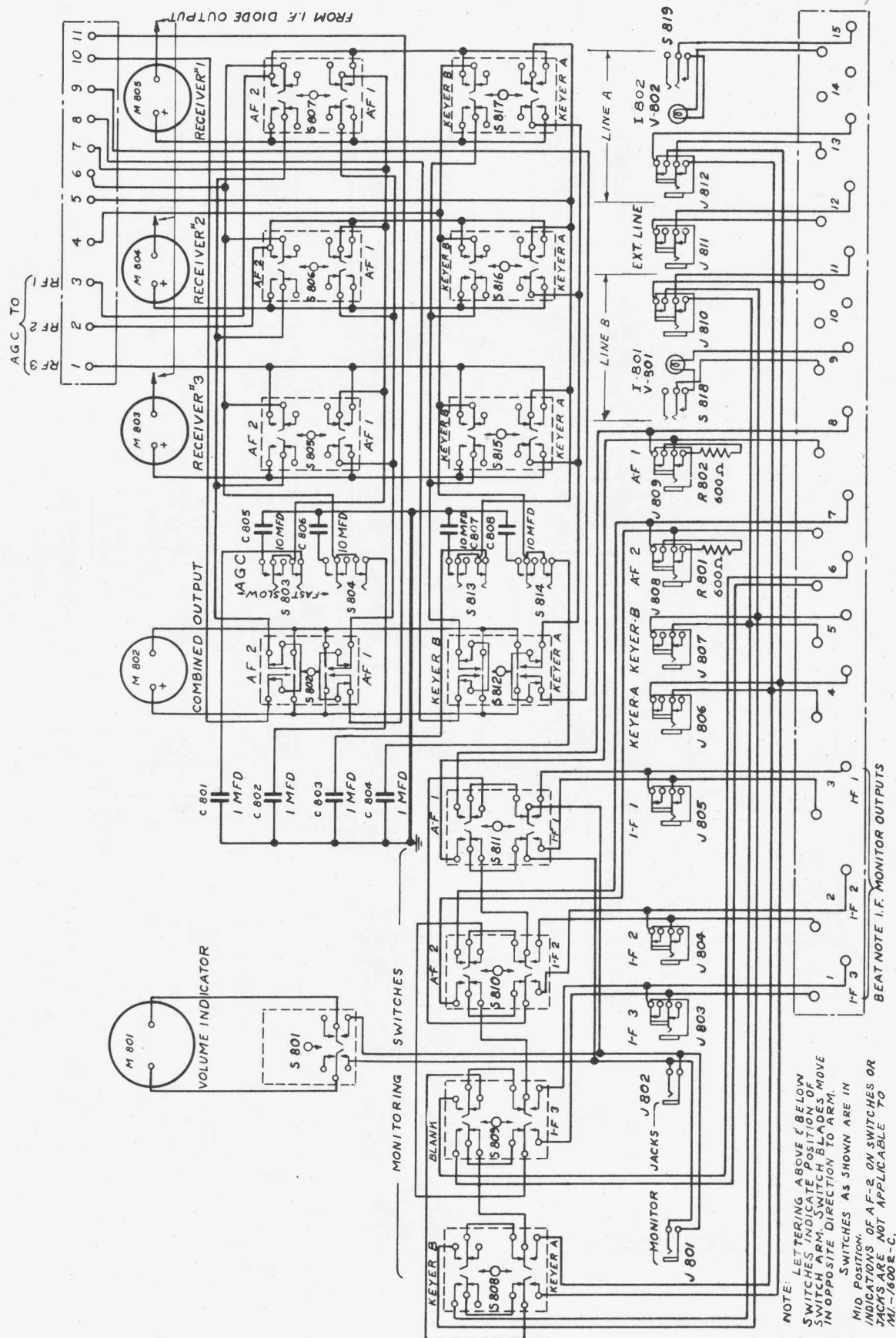
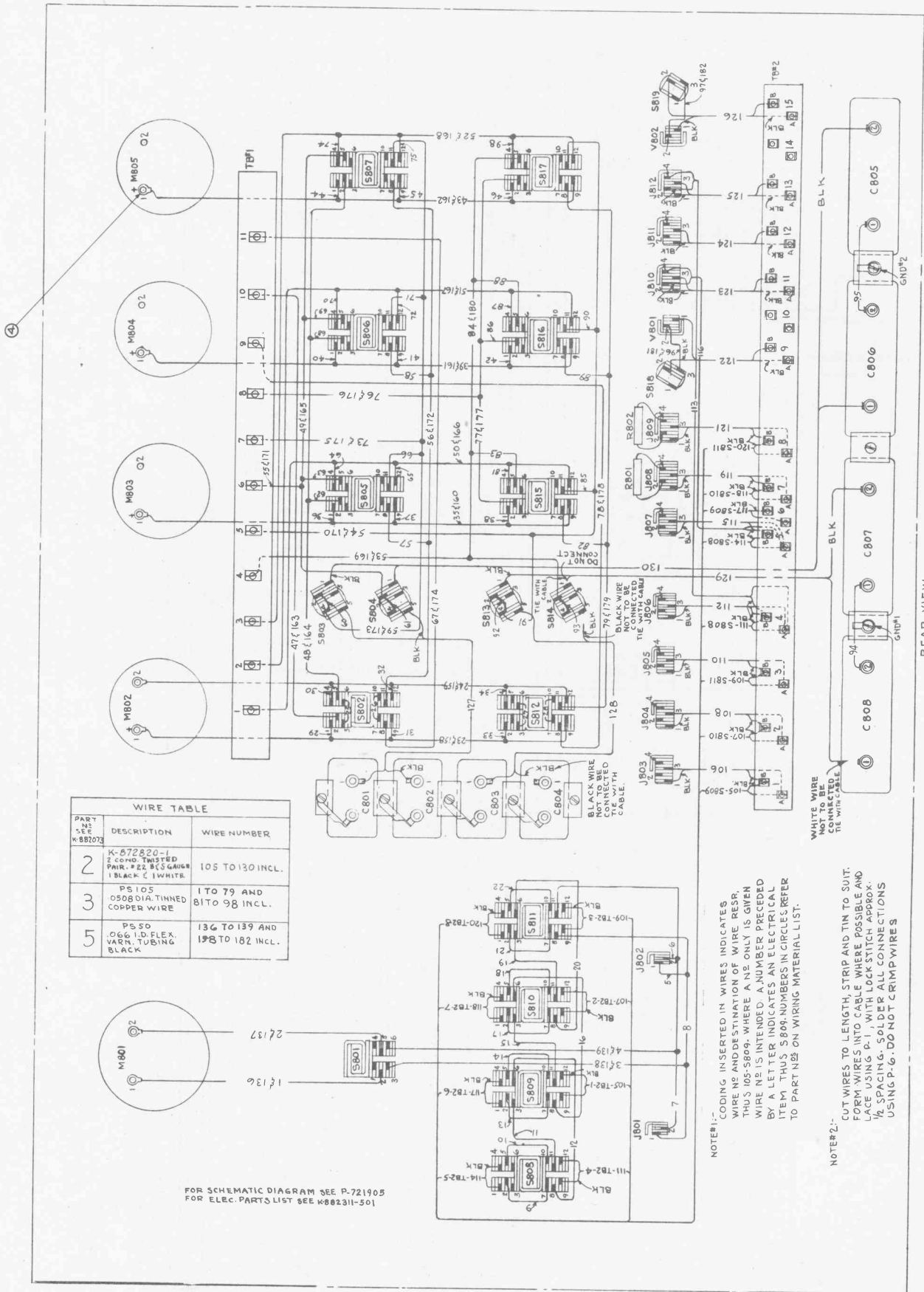

Figure 7—Type CRV-50157 Signal Control Panel Schematic (P-721907—Sub. 2)

NOTE: LETTERING ABOVE & BELOW SWITCHES INDICATE POSITION OF SWITCH ARM. SWITCH BLADES MOVE IN OPPOSITE DIRECTION TO ARM. SWITCHES AS SHOWN ARE IN MID POSITION. INDICATIONS OF AF-2 ON SWITCHES OR JACKS ARE NOT APPLICABLE TO 'M1-1600B-C'.



WIRE TABLE		
PART NO. SEE W-880703	DESCRIPTION	WIRE NUMBER
2	K-872820-1 2 COND. TWISTED PAIR, #22 B.S. GAUGE 1 BLACK & 1 WHITE	105 TO 130 INCL.
3	PS 105 OSB DIA. TINNED COPPER WIRE	110 TO 79 AND 81 TO 98 INCL.
5	PS 50 .066 I.D. FLEX. VARN. TUBING BLACK	136 TO 139 AND 178 TO 182 INCL.

NOTE1:-  
CODING INSERTED IN WIRES INDICATES WIRE NO. AND DESTINATION OF WIRE. RESP. THIS 105-8809. WHERE A NE ONLY IS GIVEN WIRE NO. IS INTENDED. A NUMBER PRECEDED BY A LETTER INDICATES AN ELECTRICAL ITEM. THIS S809 NUMBERS IN CIRCLES REFER TO PART NOS. ON WIRING MATERIAL LIST.

NOTE2:-  
CUT WIRES TO LENGTH, STRIP AND TIN TO SUIT. FORM WIRES INTO CABLE WHERE POSSIBLE AND LACE USING P-1, WITH LOCK STITCH APPROX. 1/8" SPACING. SOLDER ALL CONNECTIONS USING P-6. DO NOT CRIMP WIRES

FOR SCHEMATIC DIAGRAM SEE P-721905  
FOR ELEC. PARTS LIST SEE W-882311-501

Figure 8—Type CRV-50099 Signal Control Panel Connections (T-621135—Sub. 1)

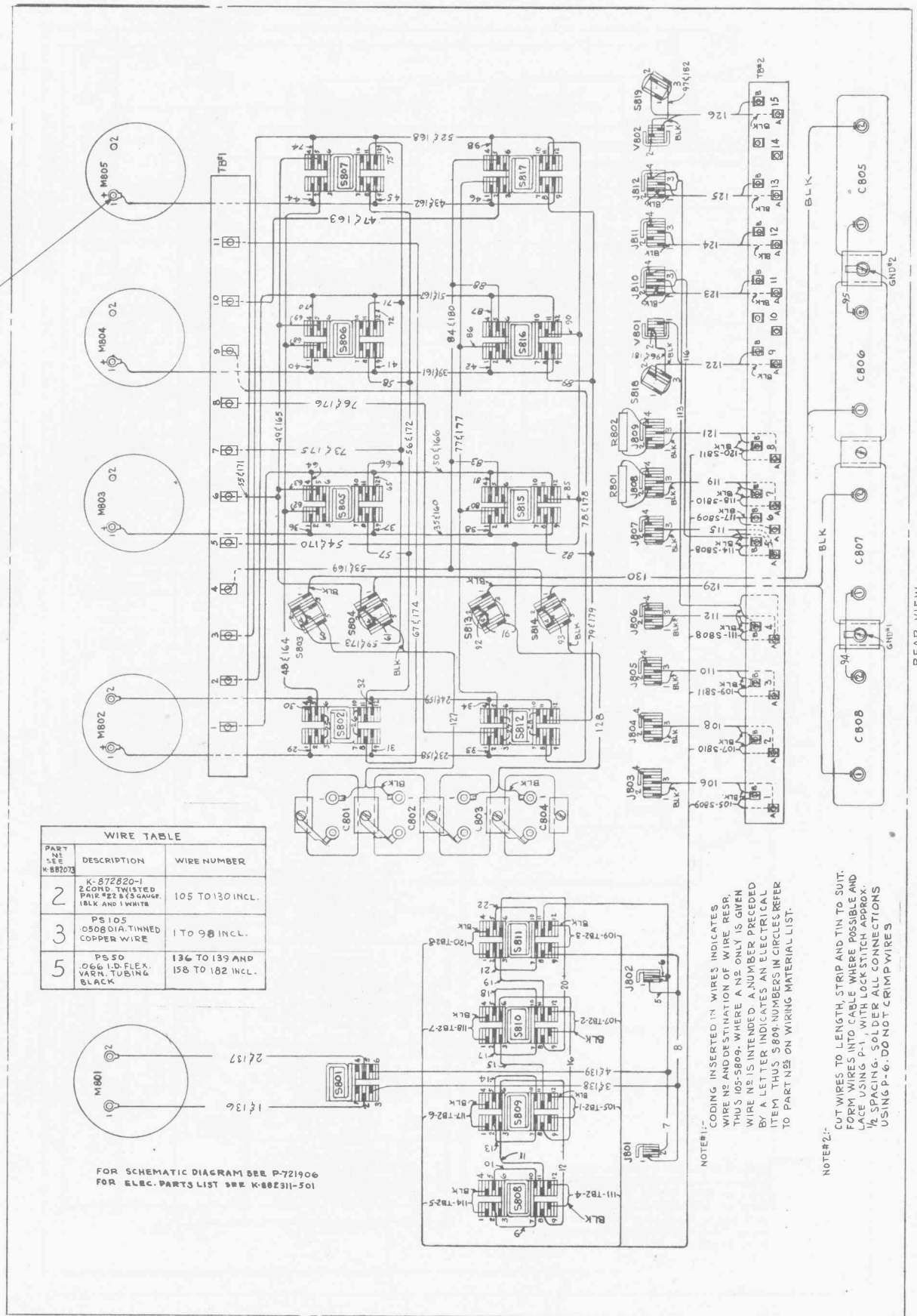

WIRE TABLE		
PART NO SEE K-88702	DESCRIPTION	WIRE NUMBER
2	K-872820-1 2 COND TWISTED PAIR #22 B (5 GAUGE, BLK AND WHITE)	105 TO 130 INCL.
3	PS 105 0508 DIA THINNED COPPER WIRE	1 TO 98 INCL.
5	PS 50 066 I.D. FLEX. VARN TUBING BLACK	136 TO 139 AND 158 TO 182 INCL.

NOTE#1:-  
CODING INSERTED IN WIRES INDICATES  
WIRE NO. AND POSITION OF WIRE. RES.  
THIS 105-5809, WHERE A 'N' ONLY IS GIVEN  
WIRE NO. IS INTENDED A NUMBER PRECEDED  
BY A LETTER INDICATES AN ELECTRICAL  
ITEM. THIS 'S809' NUMBERS IN CIRCLES REFER  
TO PART NO. ON WIRING MATERIAL LIST.

NOTE#2:-  
CUT WIRES TO LENGTH, STRIP AND TIN TO SUIT.  
FORM WIRES INTO CABLE WHERE POSSIBLE AND  
FACE USING P-1, WITH LOCK STITCH APPROX.  
1/8" SPACING. SOLDER ALL CONNECTIONS  
USING P-6. DO NOT CRIMP WIRES

FOR SCHEMATIC DIAGRAM SEE P-721906  
FOR ELEC. PARTS LIST SEE K-802311-501

Figure 9—Type CRV-50120 Signal Control Panel Connections (T-621136—Sub. 3)

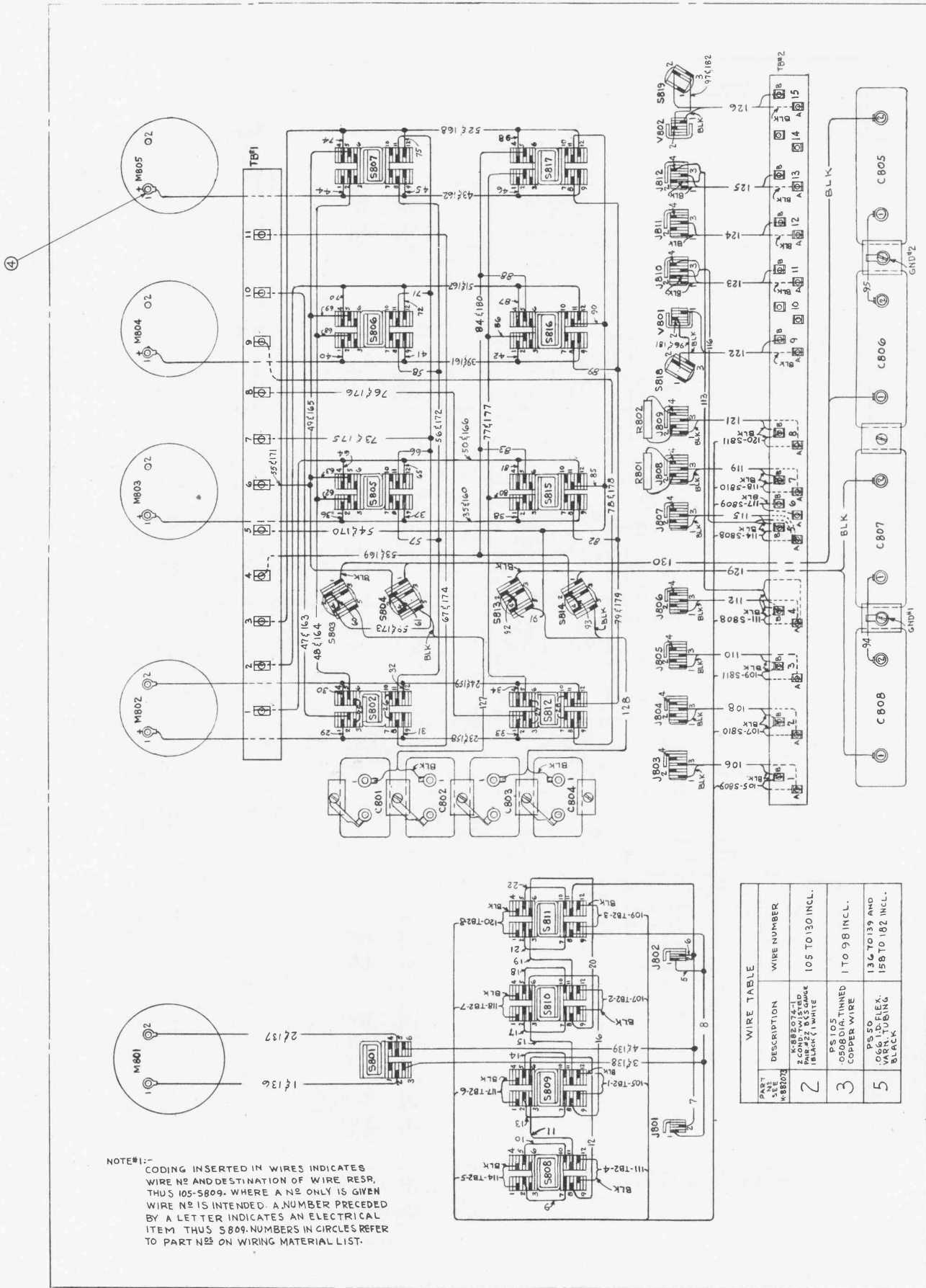

Figure 10—Type CRV-50157 Signal Control Panel Connections (T-621137—Sub. 0)