

**Restricted**

**Serial N<sup>o</sup> 233**

**MODEL RAL- 6  
RADIO RECEIVING EQUIPMENT**

**CLASS IIA, A-C OPERATED**

**Range: 0.3--23 Megacycles**

**INSTRUCTIONS**

USNR TRAINING CENTER  
WYTHE ROAD  
LYNCHBURG VIRGINIA

Manufactured for  
**NAVY DEPARTMENT— BUREAU OF SHIPS**

by

**RCA Manufacturing Company, Inc., Camden, N. J., U. S. A.**

Contract NOs-95022      Dated: 29 Dec., 1941

Contract NOs-95022      Dated: 30 June, 1942 (Sup.)



**RESTRICTED**

**SERIAL NO. 233**

**INSTRUCTIONS**  
*for*  
**MODEL RAL-6**  
**RADIO RECEIVING EQUIPMENT**  
**CLASS IIA, A-C OPERATED**  
**Range: 10.3--23 Megacycles**

The RCA Manufacturing Company, Inc., guarantees all parts and spare parts used in this equipment (with the exception of vacuum tubes) and specifically agrees to replace, at its own expense and without delay, all items found to be defective in design, material, workmanship or manufacture, within the service period of one year. This guarantee shall not obligate the manufacturer as to the replacement of defective items for more than two years, after delivery to the Government, of the items so failing, and further provided that

THIS PERIOD OF TWO YEARS AND THE SERVICE PERIOD OF ONE YEAR SHALL NOT INCLUDE ANY PORTION OF THE TIME THAT THE EQUIPMENT FAILS TO GIVE SATISFACTORY PERFORMANCE DUE TO DEFECTIVE ITEMS AND THE NECESSITY FOR REPLACEMENT THEREOF, PROVIDED ALSO THAT ANY REPLACEMENT PARTS SHALL BE GUARANTEED TO GIVE ONE YEAR OF SERVICE.

Report of failure of any part of this equipment during its service life shall be made to the Bureau of Engineering in accordance with current instructions. The report shall cover all details of the failure and shall give the date of installation of the equipment. For report of failures during the specified guarantee period, see Bureau of Engineering Circular Letter No. 40, dated 26 March, 1936, or any subsequent revision thereof.

**Manufactured for**

**NAVY DEPARTMENT — BUREAU OF SHIPS**

**by**

**RCA Manufacturing Company, Inc., Camden, N. J., U. S. A.**

**Contract NOs-95022**

**Dated: 29 Dec., 1941**

**IB-38151**

# INDEX

<i>Subject</i>	<i>Page</i>
Title Page.....	1
Index.....	2
Frontispiece.....	4
I. Introduction.....	5
II. Equipment.....	5
III. Tube Complement.....	6
IV. Power Requirements.....	6
4.1 Normal Operation.....	6
4.2 Emergency Battery Operation.....	6
V. Antenna Requirements.....	6
VI. Installation.....	7
6.1 Receiver Mounting.....	7
6.2 Power Unit Mounting.....	7
6.3 Control Unit Mounting.....	7
6.4 Wiring.....	8
VII. Tube Locations.....	9
7.1 Power Unit CRV-20131.....	9
7.2 Receiver Unit CRV-46156.....	9
VIII. Construction.....	9
8.1 Dimensions and Weight.....	9
8.2 Receiver Unit CRV-46156.....	10
8.3 Power Unit CRV-20131.....	10
8.4 Control Unit CRV-23073.....	11
IX. Circuit Description.....	11
9.1 Circuit Arrangement.....	11
9.2 Antenna Coupling.....	11
9.3 Sensitivity and Selectivity.....	11
9.4 Audio System.....	12
9.5 Power Unit.....	13
9.6 Control Unit.....	15
9.7 Interference Reduction.....	15
X. Operation.....	15
10.1 Controls of Receiver Unit CRV-46156.....	15
10.2 Controls of Power Unit CRV-20131.....	17
10.3 Controls of Control Unit CRV-23073.....	17
10.4 CW Reception.....	17
10.5 ICW or Modulated Signal Reception.....	18
XI. Performance.....	23
11.1 Sensitivity.....	23
11.2 Maximum Noise.....	23
11.3 Selectivity and Overload Selectivity.....	23
11.4 Calibration.....	24
XII. Maintenance—Trouble Location and Remedy.....	24
12.1 General.....	24
12.2 Equipment.....	24
12.3 Dead Receiver.....	24
12.4 Weak Signals with Receiver Noise Level Normal.....	26
12.5 Weak Signals with Detector Failing to Oscillate on All Bands.....	26
12.6 Weak Signals with Detector Oscillating Normally.....	26

## INDEX—(Continued)

<i>Subject</i>	<i>Page</i>
12.7 Failure of Detector to Oscillate on Some Bands; Other Bands Normal. . . .	26
12.8 Weak Signals on Some Bands; Other Bands Normal—Detector Oscillating Normally on All Bands. . . . .	26
12.9 Panel Trimmer Controls. . . . .	26
12.10 Power Supply. . . . .	27
12.11 Audio Amplifier. . . . .	28
12.12 R-F Amplifier. . . . .	28
12.13 Tube Characteristics. . . . .	28
12.14 Tube Socket Voltages. . . . .	29
12.15 Circuit Continuity. . . . .	30
12.16 Frequency Band Switch. . . . .	33
12.17 Receiver Alignment. . . . .	33
12.18 Lubrication . . . . .	34
12.19 Cleaning . . . . .	34
XIII. Parts Lists. . . . .	36
13.1 Parts List by Symbol Designations (Table No. 12) . . . . .	36
13.2 Parts List by Navy Type Numbers (Table No. 13) . . . . .	47
13.3 Spare Parts List by Navy Type Designations (Table No. 14) . . . . .	49

### Illustrations

<i>Figure</i>	<i>Page</i>
Frontispiece—Model RAL Equipment mounted with a Model RAK Equipment . . . . .	4
1—Power Unit CRV-20131 (Top View of Chassis) . . . . .	8
2—Receiver Unit CRV-46156 (Top View of Chassis) . . . . .	9
3—Receiver Unit CRV-46156 (Top View of Chassis—Covers Removed) . . . . .	10
4—Power Unit CRV-20131 (Top View of Chassis—Covers Removed) . . . . .	11
5—Control Unit CRV-23073 (Rear View of Panel) . . . . .	12
6—Receiver Unit CRV-46156 (Bottom View of Chassis—Covers Removed) . . . . .	14
7—Power Unit CRV-20131 (Bottom View of Chassis) . . . . .	14
8—Sensitivity Curve. . . . .	19
9—Maximum Noise Curve. . . . .	19
10—Average Selectivity and Overload Selectivity Bands 1 2 3. . . . .	20
11—Average Selectivity and Overload Selectivity Bands 4 5 6. . . . .	21
12—Average Selectivity and Overload Selectivity Bands 7 8 9. . . . .	22
13—Average Frequency Calibration Curves. . . . .	25
14—Receiver Unit CRV-46156 (Bottom View of Chassis) . . . . .	31

### Drawings

<i>Figure</i>	<i>Dwg. No.</i>
15—Outline and Installation. . . . .	P-720164
16—External Cable Connection Diagram. . . . .	P-721267
17—Schematic Diagram, Receiver Unit CRV-46156. . . . .	T-620490
18—Schematic Diagram, Power Unit CRV-20131. . . . .	M-422922
19—Schematic Diagram, Control Unit CRV-23073. . . . .	M-407021
20—Connection Diagram, Receiver Unit CRV-46156. . . . .	W-305684
21—Connection Diagram, Power Unit CRV-20131. . . . .	T-620092
22—Connection Diagram, Control Unit CRV-23073. . . . .	P-714101
23—Tube Socket Connections. . . . .	K-850992

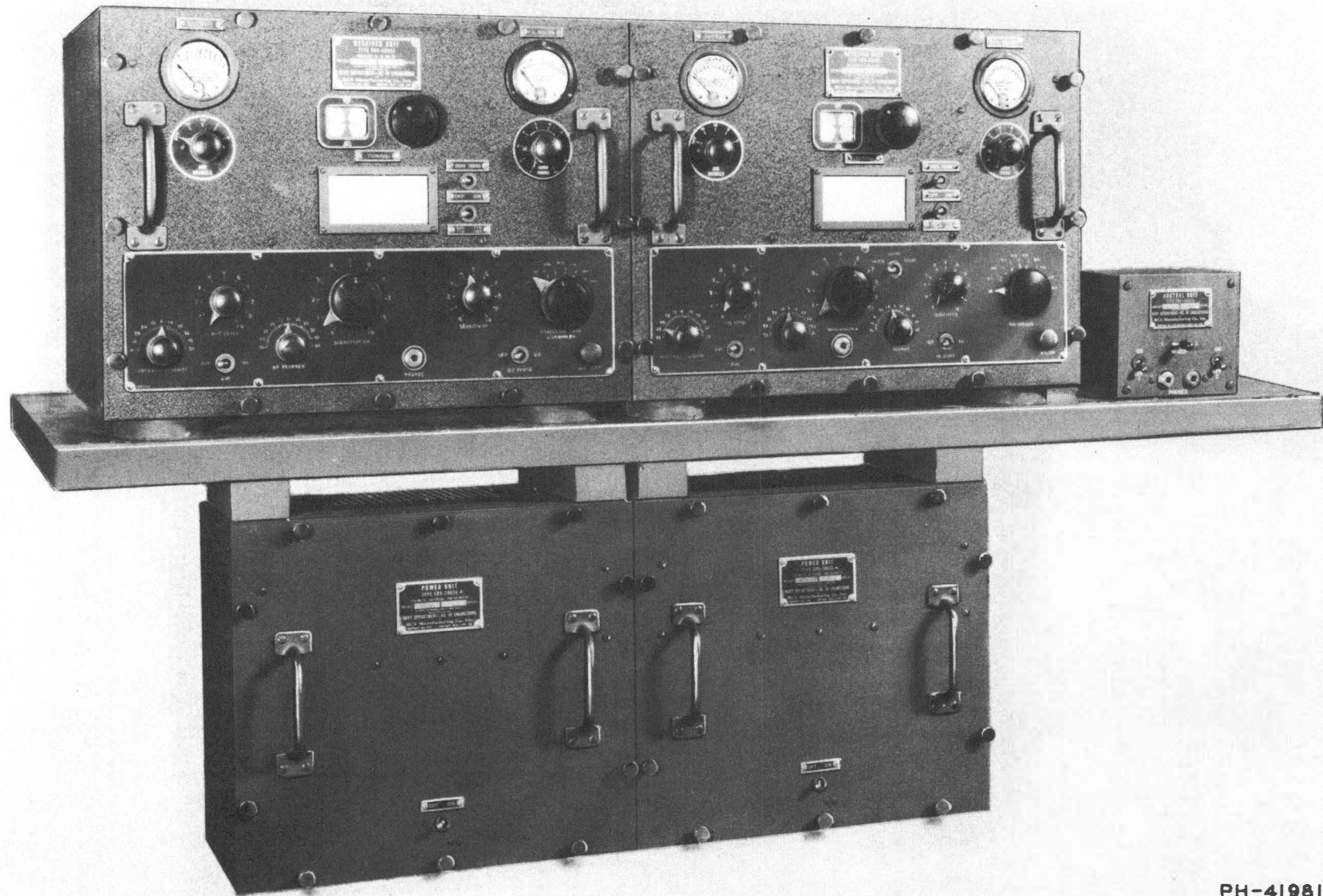

PH-41981

*Frontispiece—Model RAL Equipment mounted with a Model RAK Equipment*

# RESTRICTED

This Instruction Book is furnished for the information of commissioned, warranted, enlisted and civilian personnel of the Navy whose duties involve design, instruction, operation and installation of radio and sound equipment. The word "RESTRICTED" as applied to this Instruction Book, signifies that this Instruction Book is to be read only by the above personnel, and that the contents of it should not be made known to persons not connected with the Navy.

## I

### INTRODUCTION

- 1.1 THESE INSTRUCTIONS SHOULD BE READ AND STUDIED WITH GREAT CARE BEFORE THE INSTALLATION OR OPERATION OF THIS EQUIPMENT IS ATTEMPTED IN ORDER THAT OPTIMUM PERFORMANCE MAY BE OBTAINED.
- 1.2 These instructions cover the installation, operation, and servicing of the Model RAL-6 Radio Receiving Equipment. This receiving equipment is designed for a-c operation, being equipped with a power unit for supplying all operating voltages required from an a-c source of 110, 115, or 120 volts, 60 cycles.
- 1.3 This equipment covers the frequency range of 0.3 - 23.0 megacycles and is designed for optimum performance for the reception of pure, modulated or interrupted CW, damped radio telegraph signals, or voice modulated CW. The output circuit is designed for use with one pair of 600-ohm phones.
- 1.4 The RAL Series equipment is designed for independent operation but is so designed with respect to size, shape and mechanical arrangement as to permit installation adjacent to an RAK Series equipment forming a complete two-channel equipment suitable for guarding two frequencies simultaneously by one operator. A separate control unit, Type CRV-23073, may be used for this installation to provide greatest flexibility of operation. This unit is described in a subsequent section of this instruction book.

## II

### EQUIPMENT

- 2.1 Each equipment consists of the following major component units:
  - (a) Receiver Unit, Type CRV-46156.
  - (b) Power Unit, Type CRV-20131.
  - (c) Control Unit, Type CRV-23073. (Not furnished with Model RAK Series Equipment.)
- 2.2 In addition to the major units, each complete equipment includes the following items:
  - (a) Spare parts box, containing spares for major units.
  - (b) Cables, as follows:

<i>Item</i>	<i>Quan.</i>	<i>Description</i>	<i>Dwg. No.</i>
W-101	1	Cable, output, 2-conductor, shielded	P-701688-505
W-102	1	Cable, output of filter to receiver	K-871377-501
W-201	1	Cable, power, 4-conductor, shielded	P-701688-504
W-301	2	Cable, a-c supply, 2-conductor	P-701688-503

- (c) Shock absorbers, as follows:

<i>Item</i>	<i>Quan.</i>	<i>Description</i>	<i>Dwg. No.</i>
SA-101 {A	4	Shock absorber, upper portion, 1 1/8" thick	K-806699-5
{B	4	Shock absorber, lower portion, 1/2" thick	K-806699-4

(d) Miscellaneous mounting hardware, as follows:

Item	Quan.	Description	Dwg. No.
H-101	4	Bolt, 1/2"-13, 3 1/2" long, hex. head	K-806306-3
H-102	4	Washer, flat, 2" O.D., 9/16" I.D., 0.1285" thick	K-806304-1
H-103	8	Nut, 1/2"-13, hexagonal	K-59149-33

**Note:** All necessary hardware for interlocking the receiver and power units of the Models RAK and RAL Equipments are furnished only with the Model RAK.

### III

#### TUBE COMPLEMENT

3.1 The following Navy standard vacuum tubes are required for each equipment:

- |   |                                |
|---|--------------------------------|
| 4—Type -6D6 R-F Amplifiers, Detector and Audio. | 1—Type -5Z3 Rectifier.         |
| 2—Type -41 Output and AVC.                      | 1—Type -874 Voltage Regulator. |
|   | 1—Type -876 Current Regulator. |

### IV

#### POWER REQUIREMENTS

4.1 Normal Operation.

4.1-1 The receiver is designed to operate from a 110-, 115-, or 120-volt, 60-cycle, single-phase, a-c supply with a fast and slow voltage variation not exceeding  $\pm 10\%$ .

4.1-2 The total power consumption of the RAL Series equipment is approximately 200 watts.

**NOTE:** THE RAL EQUIPMENT SHOULD NOT BE OPERATED UNDER ANY CONDITION WITHOUT THE CURRENT-REGULATOR TUBE IN THE POWER UNIT BEING USED.

4.2 Emergency Battery Operation.

4.2-1 The filament supply may be obtained from a 6-volt storage battery. The current drain is approximately 2 amperes.

4.2-2 A single "B" potential of 180 volts is required. This supply may be either a storage battery or a suitable combination of dry cell batteries. The current drain is approximately 45 milliamperes. No "C" batteries are required.

### V

#### ANTENNA REQUIREMENTS

5.1 This equipment is designed primarily for operation with a separate antenna not used for other equipment. However, the Model RAL Equipment may be operated on an antenna common with the Model RAK Equipment as an emergency measure. The antennas should be spaced at least 6 feet from any parallel stay, mast or stack, must be well insulated and erected as high as possible. The length of antenna should be approximately 50 feet in the clear. The antenna lead connecting to the receiver should be flexible insulated cable to prevent shorting to the receiver chassis.

**NOTE:** NO OTHER RECEIVER SHOULD BE USED ON THE SAME ANTENNA WITH THIS EQUIPMENT EXCEPT AS AN EMERGENCY MEASURE.

5.2 When it is necessary to operate this equipment from an antenna common to an RAK equipment as an emergency measure, the antenna should be connected to the binding post marked "COMMON."

5.3 When using the "COMMON" antenna connection, a 1/2-megohm static drain resistor should be installed between antenna and ground.

5.4 The ground connection should be made to some grounded metal portion of the ship as specified under "Wiring" (paragraph 6.4-2) and should be soldered, if practicable, to prevent variable- or high-resistance contact due to corrosion.

5.5 The use of bonded stays is equally as desirable with this equipment as with other Navy receivers to eliminate noises arising from variable contacts or grounds on such stays.



## VI

### INSTALLATION

#### 6.1 Receiver Unit Mounting.

- 6.1-1 It is essential that the receiver unit be secured to its table by means of the rubber shock absorber mounting provided. Figure 15 illustrates in detail the manner in which these receivers are to be installed, including dimensions for drilling the operating table or desk. In planning this installation, care should be exercised to provide for clearance of at least three inches or more from the back of the receivers to the bulkhead or nearest obstruction in order to permit movement of cables when withdrawing the chassis from the cabinets for servicing. Should these receivers be operated in pairs, the cabinets must be bolted together and in place after the chassis have been removed. To remove the receiver chassis, it is necessary to loosen the thumb screws holding the front panel to the cabinet. These thumb screws do not come clear of the panel. If the equipment has been previously set up, it will be necessary to disconnect the cables to the auxiliary equipment. Using the handles provided on the front panel, remove the chassis completely from the cabinet. **CARE SHOULD BE TAKEN TO SET THE CHASSIS ON A FLAT SURFACE FREE FROM ANY OBJECTS WHICH MIGHT DAMAGE THE SHIELDING.**
- 6.1-2 The several cables of this equipment should be fed through the holes in the rear of the cabinet and connected as shown in Figure 16. The large shielded cable (W-201) connects the receiver unit to the power unit. A smaller shielded cable (W-101) connects the control unit (its use being optional) to the receiver unit while another cable (W-301) connects the power unit to the control unit. Should only one receiver unit and no control unit be used, refer to Figure 16 for the power cord connections.
- 6.1-3 Using a one-inch drill, pierce the top of the desk in accordance with the dimensions given in Figure 15. Place one rubber shock absorber (SA-101A) in each of these holes. Locate the cabinets in their proper positions on the desk top so that their mounting holes coincide with the holes in the shock absorbers and insert the mounting bolts. Next, place the bottom shock absorber (SA-101B), a metal washer, nut and locknut on each bolt as shown in Figure 15 but do not tighten the nuts. In case two receivers are used together, bolt the adjacent sides by means of the short bolts provided. Place these bolts in the holes inside the cabinets. Place washers under the heads and washers, lockwashers and nuts on the opposite end of the bolt. Before tightening these nuts, carefully align the cabinets both horizontally and vertically. When the cabinets have been secured to each other, tighten the mounting bolts just sufficiently to slightly compress the rubber shock absorbers.

#### 6.2 Power Unit Mounting.

- 6.2-1 The power unit cabinet should be mounted beneath the operating table by means of four bolts, washers and lockwashers (not supplied). It should be spaced a minimum of  $1\frac{1}{2}$  inches from the bottom of the table by cleats or other means so as to allow ample ventilation. The details of the installation and the drilling plan for these mounting bolts are also shown in Figure 15. Remove the power unit from the cabinet by first loosening the panel thumb screws and then withdraw by means of the two handles provided on the panel. If the equipment has been previously set up, it will be necessary to remove the cable connections from the terminal board at the right-hand side of the power unit, just in back of the panel. For further details, see Figure 16.

#### 6.3 Control Unit Mounting.

- 6.3-1 The control unit cabinet should be mounted at any convenient place on the operating table by means of two bolts through two holes provided in the bottom of the cabinet and fastened securely with lockwashers and nuts. To remove the chassis, unloosen the four screws in the panel. Use of the control unit is optional with this equipment, its operation being described in paragraph 9.6.

## 6.4 Wiring.

- 6.4-1 The wiring between units is shown in Figure 16. At installation, the supply voltage should be measured or otherwise ascertained and the primary taps of the power transformer (T-201) shifted if necessary to comply with the nominal line rating. These taps are connected at the factory for 115 volts as indicated by the marking "115" adjacent to the terminals to which the red wires from toggle switch S-202 is connected (see Figures 1, 4 and 21.) If the supply voltage is nearer 110 or 120 volts than 115 volts, shift these red wires to one of the two other pairs of terminals (marked "110" and "120," respectively) as required. To eliminate as much a-c hum and other electrical interference as possible, the 110-, 115-, or 120-volt, a-c supply should be connected to the power unit by a shielded twisted pair of wires (No. 14 or larger), or run in grounded conduit as far as the bulkhead adjacent to the power unit and terminated in a junction box. In no case should transformers or other a-c equipment be located in close proximity to the receiver.
- 6.4-2 Grounds should be made to some grounded metal portion of the ship. Contact surfaces must be scraped free from paint. Pipes should be avoided since they are a questionable ground aboard ship.  
**NOTE: THE IMPORTANCE OF SECURING A GOOD GROUND WITH A SHORT, DIRECT, LOW RESISTANCE GROUND LEAD CANNOT BE OVER-EMPHASIZED. THIS IS OF PARTICULAR IMPORTANCE IN MINIMIZING PICKUP AND INTERFERENCE FROM NEARBY TRANSMITTERS.**
- 6.4-3 Sufficient slack should be left in sections of cables external to cabinets to permit withdrawal of chassis from cabinets for service checking with voltages applied.
- 6.4-4 Emergency Battery Operation.  
Referring to Figure 16, Cable W-101 is used to connect the receiver output to the output line or to the control unit if used. In an emergency, should it be desired to operate the receiver on batteries, Cable W-201 connects the receiver unit to a battery terminal block (not supplied). The battery terminal block must be arranged to supply screw terminals for connection to the spade terminals of Cable W-201. Wiring from the batteries to the terminal block should be run in grounded conduit and the filament wiring should be of sufficient size to offer negligible voltage drop (each receiver draws approximately 2 amperes filament current).

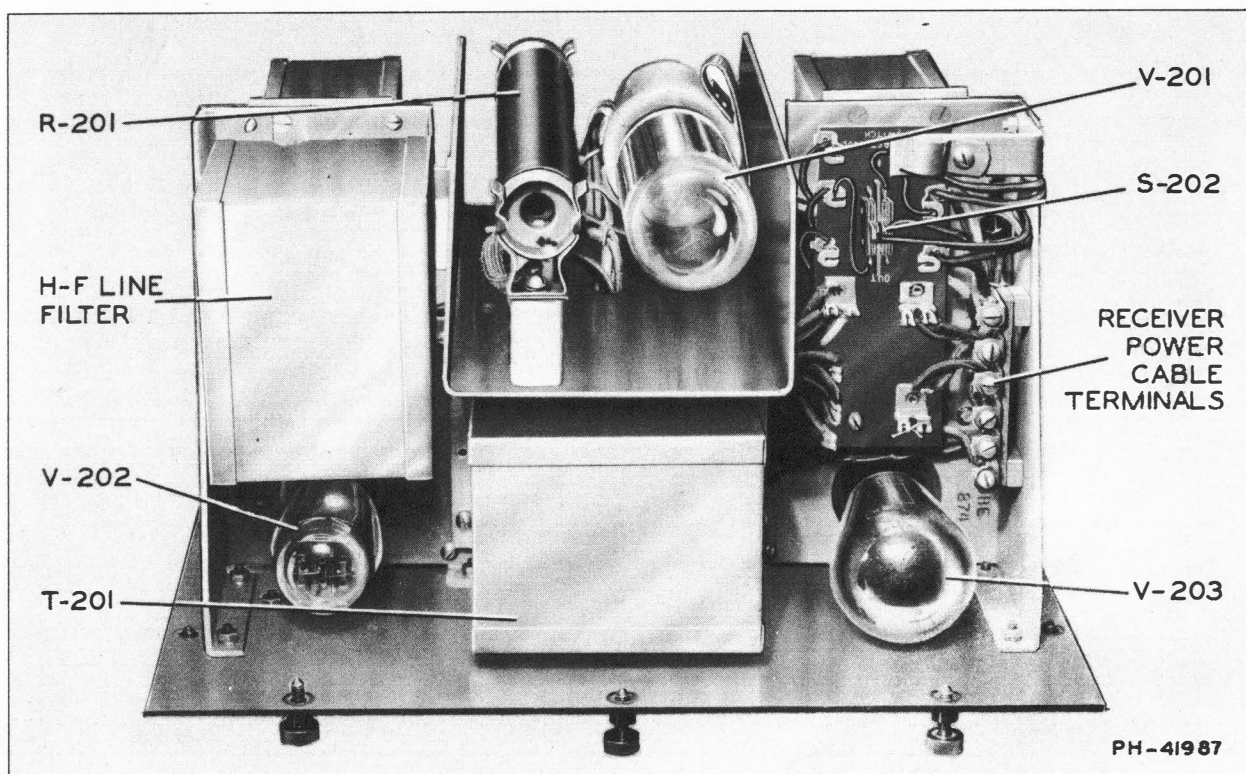

Figure 1—Power Unit CRV-20131 (Top View of Chassis)

## VII TUBE LOCATIONS

### 7.1 Power Unit CRV-20131.

7.1-1 The tube locations are shown in Figures 1 and 16.

- (a) Type -5Z3 rectifier, left front of chassis.
- (b) Type -874 voltage regulator, right front of chassis.
- (c) Type -876 current regulator, center rear.

### 7.2 Receiver Unit CRV-46156.

7.2-1 The tube locations are shown in Figures 2 and 16.

- (a) Type -6D6 first r-f, rear left of chassis.
- (b) Type -6D6 2nd r-f, rear center of chassis.
- (c) Type -6D6 detector, rear right of chassis.
- (d) Type -41 output limiter (AVC), left front of chassis.
- (e) Type -41 audio output, center front of chassis.
- (f) Type -6D6 first audio, right front of chassis.

## VIII CONSTRUCTION

### 8.1 Dimensions and Weights.

8.1-1 Figure 15 illustrates the overall dimensions of the RAL and RAK equipments as arranged for installation. The weights of the units are as follows:

- (a) Type CRV-46156 Receiver Unit. . . . . 69 lbs.
- (b) Type CRV-20131 Power Unit. . . . . 41 lbs.
- (c) Type CRV-23073 Control Unit. . . . . 2 lbs.

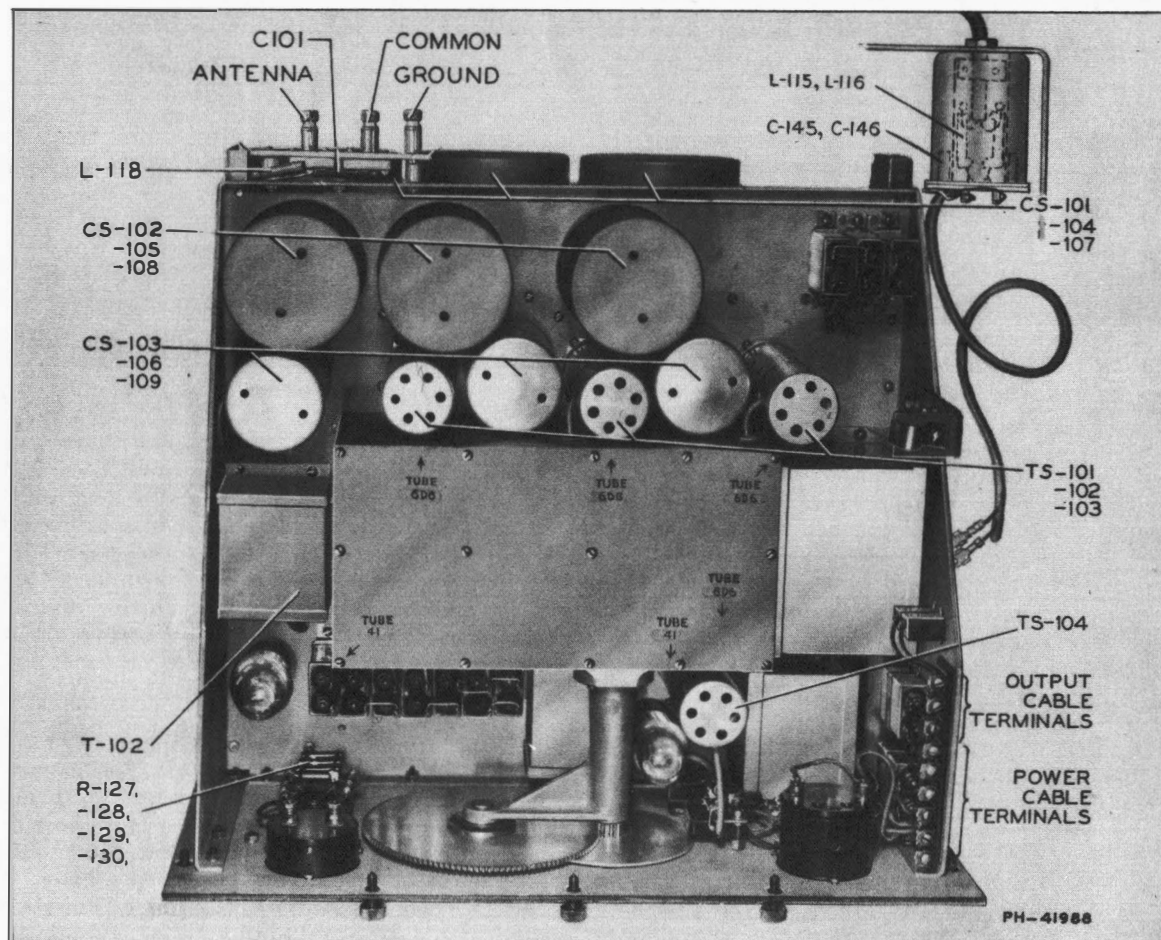

Figure 2—Receiver Unit CRV-46156 (Top View of Chassis)

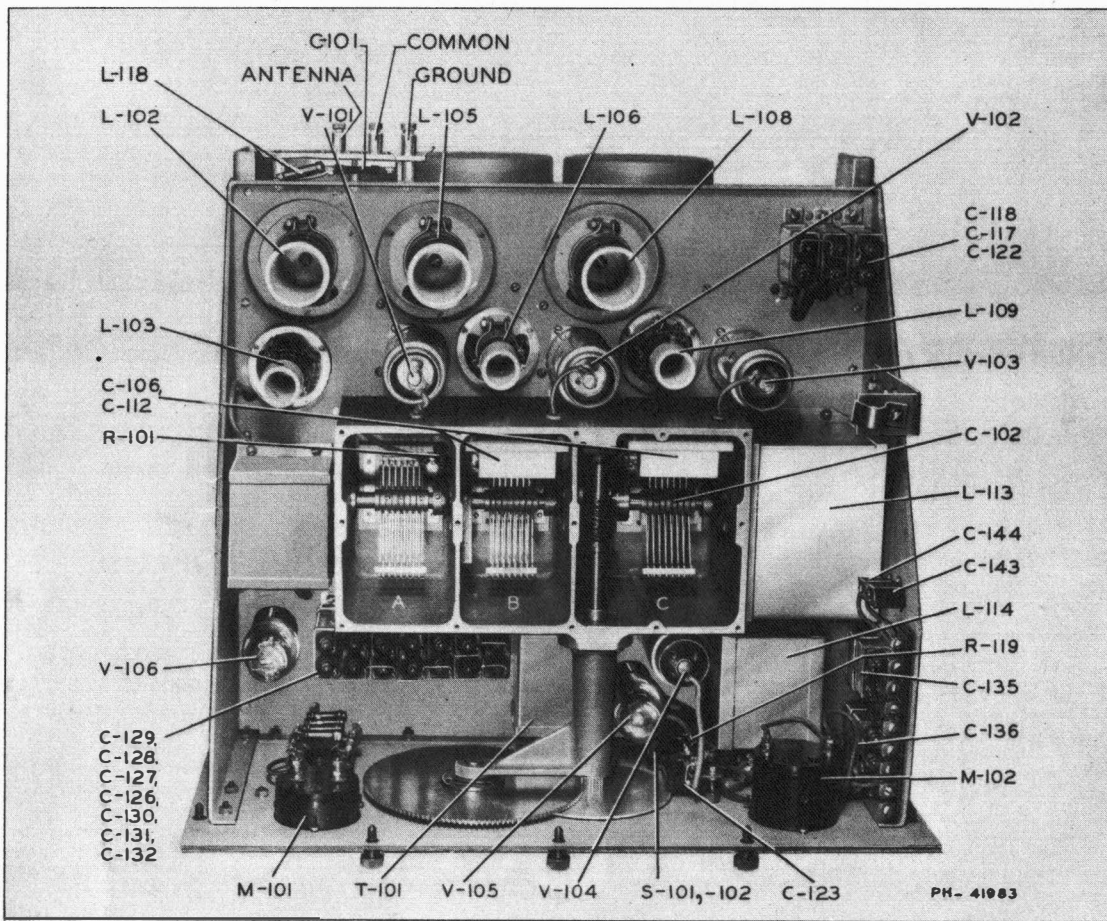

Figure 3—Receiver Unit CRV-46156 (Top View of Chassis—Covers Removed)

## 8.2 Receiver Unit CRV-46156.

8.2-1 As indicated in Figure 15, the receiver unit is designed for table mounting. The cabinet may be permanently fastened to the table and the chassis is removable for access to tubes, for servicing, and for cable connections. All components are mounted on the chassis or panel forming a single assembly. (See Figures 2, 3 and 6.) Audio and AVC components are mounted directly behind the panel with filter and audio tuning units at the right, the first audio and output tubes in the center, and the AVC circuit at the left. Audio wiring, resistors, etc., are located beneath the chassis. The tuning condenser assembly is located just back of the audio components. The top plate on the condenser assembly is removable for inspection. At the rear of the chassis are located the r-f and detector tubes and the r-f coils, which are protected and shielded by screw cans. The power terminals are located at the right of the chassis and the antenna and ground terminals at the left. The band switch, r-f components and wiring are located beneath the chassis in a fabricated shield box. The large cover plate on the bottom of the receiver is removable for inspection and access to these parts.

## 8.3 Power Unit CRV-20131.

8.3-1 The power unit is designed for mounting underneath a table (see Figure 15). The cabinet may be permanently mounted, the chassis being removable for access to tubes, for servicing, and for cable connections. All components are mounted on the chassis or panel forming a single assembly. (See Figures 1, 4 and 7.) On the top of the chassis from left to right are located the rectifier tube, h-f line filter shield, power transformer, voltage regulator tube, resistor board and power terminals. The line filter shield at the left rear is removable for access to the line input terminals and fuses. In the center at the rear is located the current-regulator tube. Beneath the chassis from left to right are located the l-f line filter, ripple filter reactors, and ripple filter capacitor pack.



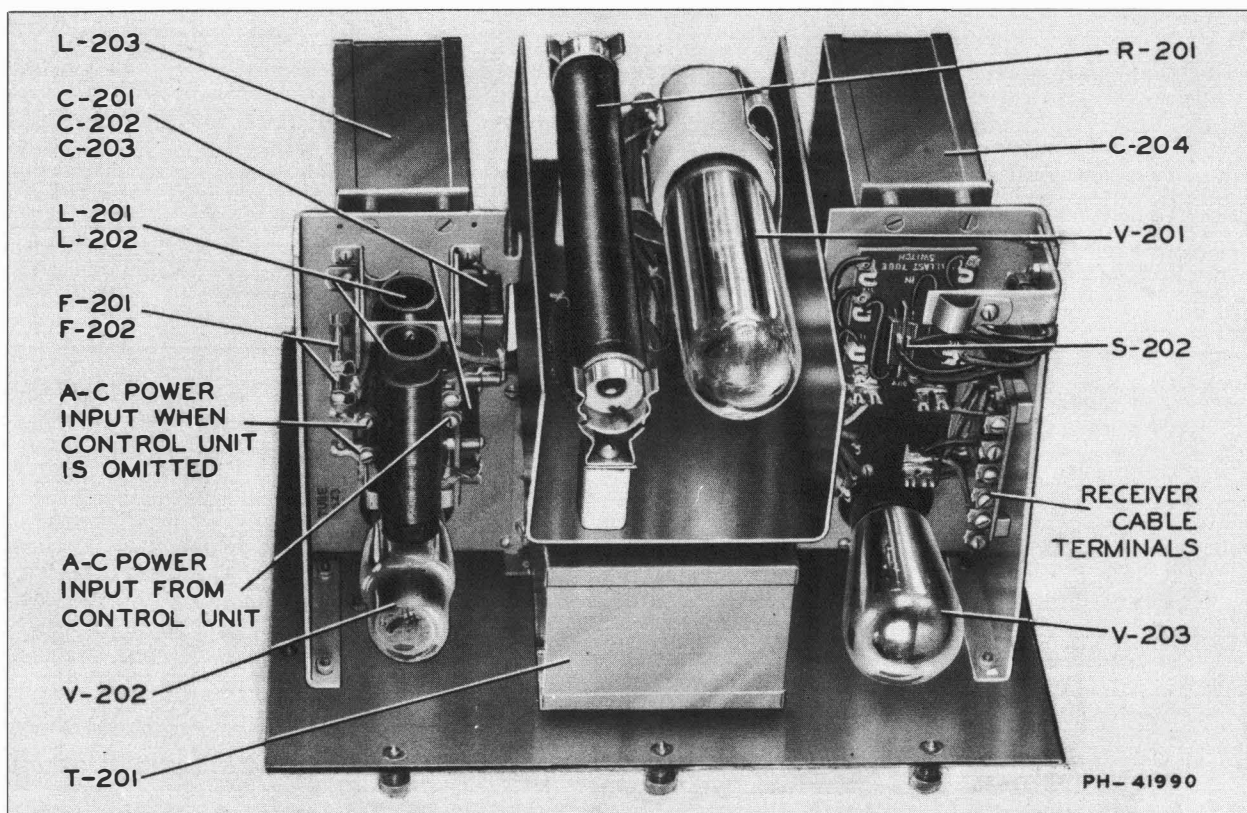

Figure 4—Power Unit CRV-20131 (Top View of Chassis—Covers Removed)

#### 8.4 Control Unit CRV-23073.

- 8.4-1 The control unit contains output jacks, mixer switch and power switches mounted on the panel. (See Figure 5.) Fuses and terminal boards are mounted on a bracket secured to the panel. The case may be permanently mounted to any flat surface (see Figure 15).

## IX

### CIRCUIT DESCRIPTION

- 9.1 The schematic diagram of the receiver unit (Figure 17) shows the arrangement of the radio- and audio-frequency circuits.
- 9.2 The antenna is inductively coupled to the first tuned circuit, the coupling being designed to give optimum energy transfer in order to secure the best possible signal-to-noise ratio. When it is necessary to operate this receiver on the same antenna with an RAK equipment, looser coupling is desirable. The antenna binding posts, therefore, have been so arranged that a capacitor is placed in series with the antenna coupling coil when connection is made to the binding post marked "Common".
- 9.3 The requisite sensitivity and selectivity at the signal frequency is obtained by the use of two r-f stages and a regenerative detector stage. Uni-control is accomplished by means of a 3-gang variable capacitor, tuning the two r-f stages and the detector.

- 9.3-1 The frequency range of 0.3 to 23 megacycles is covered in nine bands by means of

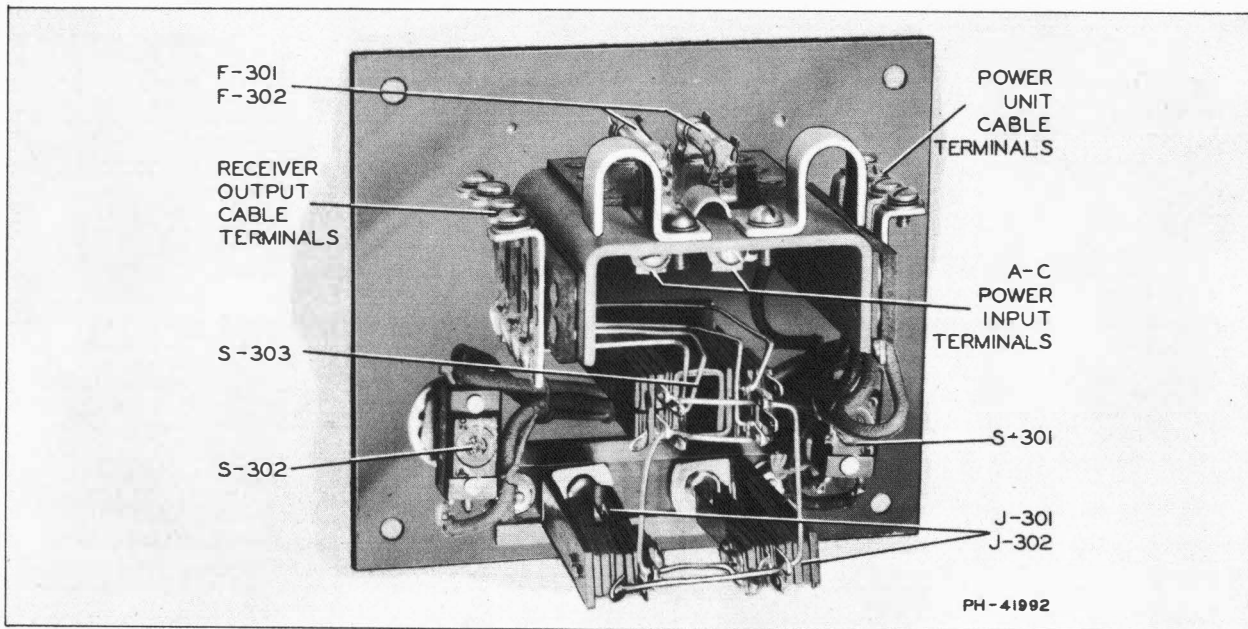

Figure 5—Control Unit CRV-23073 (Rear View of Panel)

coil switching as shown on the schematic diagram. The necessary inductances are wound on three sets of coil bodies. Unused portions of the coils are grounded or short circuited where they would otherwise cause undesirable losses in the tuned circuit.

- 9.3-2 Two Type -6D6 tubes are used as r-f amplifiers and a third Type -6D6 is used, as a regenerative detector.
- 9.3-3 In order to hold the sensitivity of the receiver essentially constant over the wide frequency range employed and to improve selectivity, the plate circuit of the first r-f amplifier stage is tapped down on its tuning impedance for bands 4 to 9 and transformer coupling is used for bands 1 to 3. Transformer coupling also is employed between the plate of the second r-f stage and the grid of the detector.
- 9.3-4 CW reception and improved sensitivity and selectivity is accomplished by the use of a specially designed autodyne detector circuit. This detector employs the familiar electron coupling with the resultant minimizing of reaction in all circuit switching in the audio system. A very high degree of frequency stability is inherent in this type of circuit. The particular design obviates the necessity for frequent adjustment of the "Regeneration" control and renders it possible to obtain the desired performance characteristics of this detector without critical adjustments of the control.
- 9.3-5 Sensitivity is controlled by varying the cathode potential of the two r-f stages with respect to the grid potential of those stages.
- 9.3-6 In order to obtain optimum performance of the equipment under all service conditions, small trimmer capacitors adjustable from the front panel are provided on the first and second r-f tuned circuits.
- 9.3-7 To permit greater ease in searching and following drifting signals, a very small trimmer capacitor (frequency vernier) controllable from the front panel has been provided. This adjustment makes possible the variation of the autodyne oscillator frequency by an amount between .35% and .05% of its frequency. The greater range of adjustment is obtained at the high-frequency ends of the various bands.
- 9.3-8 The unit is completely shielded both internally and externally to minimize cross talk between receivers. All power leads are filtered with resistance-capacity filters. Inter-stage shielding is provided to increase selectivity and stability and to minimize reaction.
- 9.4 The audio system includes two stages of amplification and an output limiter. Filters are provided which increase the effective CW selectivity and improve the signal-to-noise ratio.
  - 9.4-1 A low-pass filter immediately follows the detector circuit and may be disconnected from the circuit by means of a switch on the front panel. This filter provides attenuation of less than 6 db at 1200 cycles and more than 40 db at frequencies above 1600 cycles.

- 9.4-2 A variable audio-frequency attenuator which may be switched in or out of the circuit by means of a panel control follows the low-pass filter. This attenuator operates over the range of 450-1300 cycles (this indicates "acceptance" of the frequency to which the attenuator is adjusted and "attenuation" of other frequencies). A choice of resonant frequency is afforded by means of a 10-position switch and a 2-position range switch. Schematically, this attenuator is a tuned circuit inserted in parallel with the grid of the first audio stage.
- 9.4-3 A Type -6D6 tube is used in the first audio-frequency amplifier stage.
- 9.4-4 The first audio stage is resistance coupled to a Type -41 output stage which, in turn, is transformer coupled for use with an output impedance of approximately 600 ohms. The output transformer employs an electrostatic shield and a center-tapped output winding to obtain a balanced output circuit.
- 9.4-5 A switch operated from the front panel permits an audio limiter tube (Type -41) to operate on the plate circuit of the output stage. The switch connects the output limiter transformer in parallel with the primary of the output transformer. The output limiter transformer has a high voltage step-up ratio and feeds the Type -41 tube which is connected as a biased rectifier. When the receiver output reaches a certain level (determined by an adjustable bias on the rectifier), the rectifier starts drawing grid current and the rectifier grid resistance decreases. This resistance reflected through the high-ratio transformer results in a low effective impedance load in the receiver output stage plate circuit, and thus limits the output voltage to a certain value. Since the AVC is operated by audio output only, it is not affected by strong CW signals which do not produce an audio beat note. The output level to which the signal is limited may be varied by adjustment of the rectifier bias from the control on the front panel.
- NOTE:** THIS CONTROL IS NOT INTENDED FOR USE ON VOICE MODULATED SIGNALS SINCE IT INTRODUCES HARMONICS OF THE AUDIBLE NOTE AND PRODUCES PROHIBITIVE DISTORTION.
- 9.4-6 A rectifier type DB output meter and range switch are provided on the front panel. This meter indicates the audio level delivered to the headphones.
- 9.4-7 A voltmeter which indicates filament voltage is provided on the front panel.
- 9.4-8 Normally, the a-c power is controlled either from the control unit or the power unit. In addition, a d-c power "On-Off" switch is provided on the receiver panel for use only in the event the receiver in an emergency is operated on batteries. *If this switch is opened when the receiver is normally operated on a.c., the load is removed from the power unit and overloading and damage of certain of its parts may result.* For this reason, shorting links are provided behind the panel (see Figure 6) which permanently close this switch circuit. If it is desired in an emergency to operate the receiver on batteries, these links should be opened.
- 9.5 Power Unit CRV-20131, shown schematically in Figure 18, has been very carefully designed in order to maintain an accurate calibration of the receiver and a high degree of frequency stability. Several special features are embodied in the design in order to afford very constant voltage on all of the tubes used in the receiver unit and particularly on the screen grid of the autodyne detector which is the element principally affected by power supply voltage variation. The power supply circuit consists essentially of r-f filters on the a-c supply line, a Type -876 current regulator, an electrostatically shielded power transformer, a Type -5Z3 rectifier tube, a specially developed two-stage filter, a Type -874 voltage regulator and a protective bleeder.
- 9.5-1 The r-f filter unit has been very carefully designed to substantially eliminate cross talk between several equipments operating from one power supply system and to reduce interference which may be present on the a-c line.
- 9.5-2 The power transformer has been designed for operation from a 110-, 115-, or 120-volt, 60-cycle supply, and taps are provided on the primary to accommodate any of these nominal voltages. The total power consumption of this transformer under normal operation (with the current regulator tube in use) is approximately 200 watts. Filament supply is obtained from a center-tapped winding on this transformer and is, therefore, regulated by the current-regulator tube.
- 9.5-3 The Type -5Z3 rectifier tube and bleeder provide a plate source of good regulation.
- 9.5-4 The screen voltage of the autodyne detector is stabilized by means of a Type -874 regulator tube.

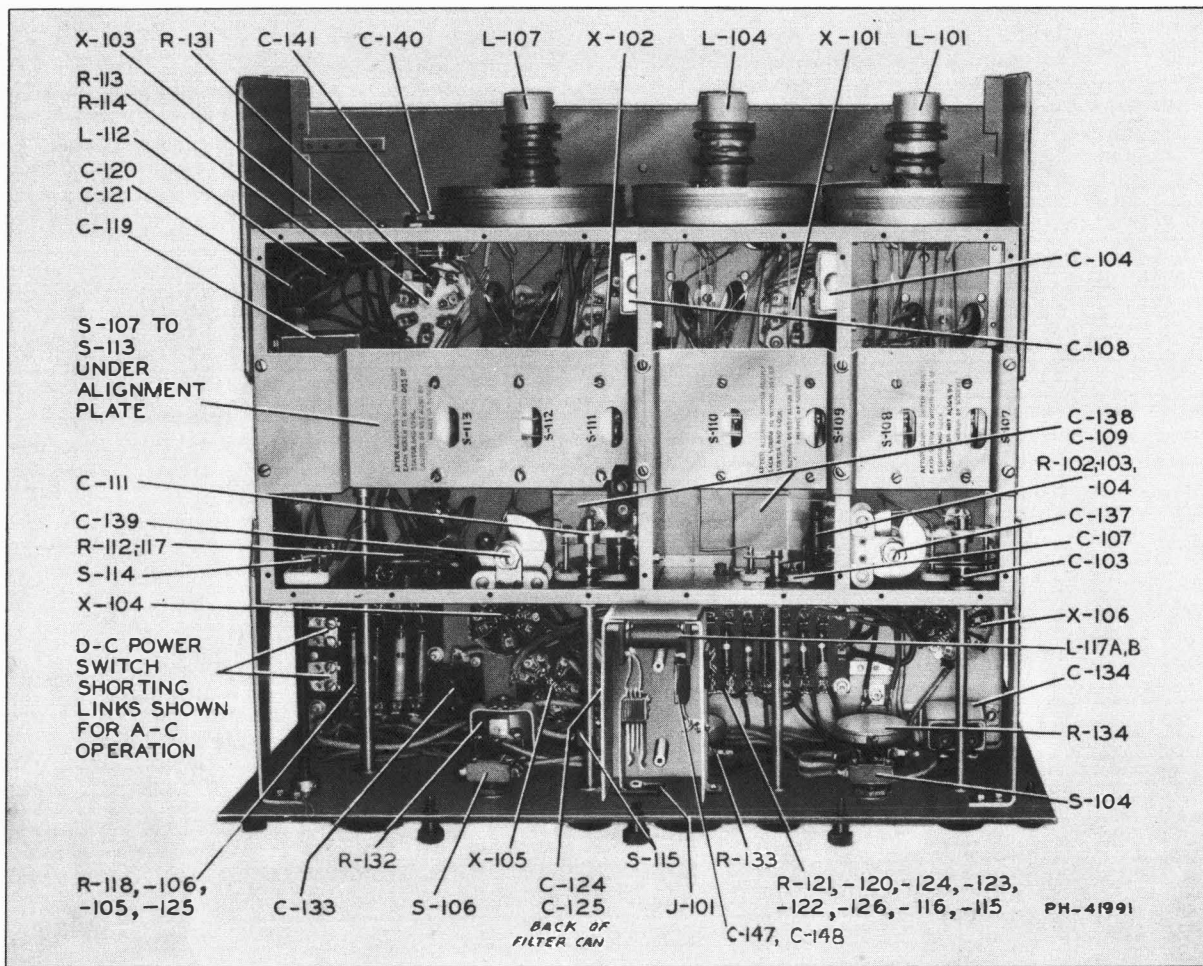

Figure 6—Receiver Unit CRV-46156 (Bottom View of Chassis—Covers Removed)

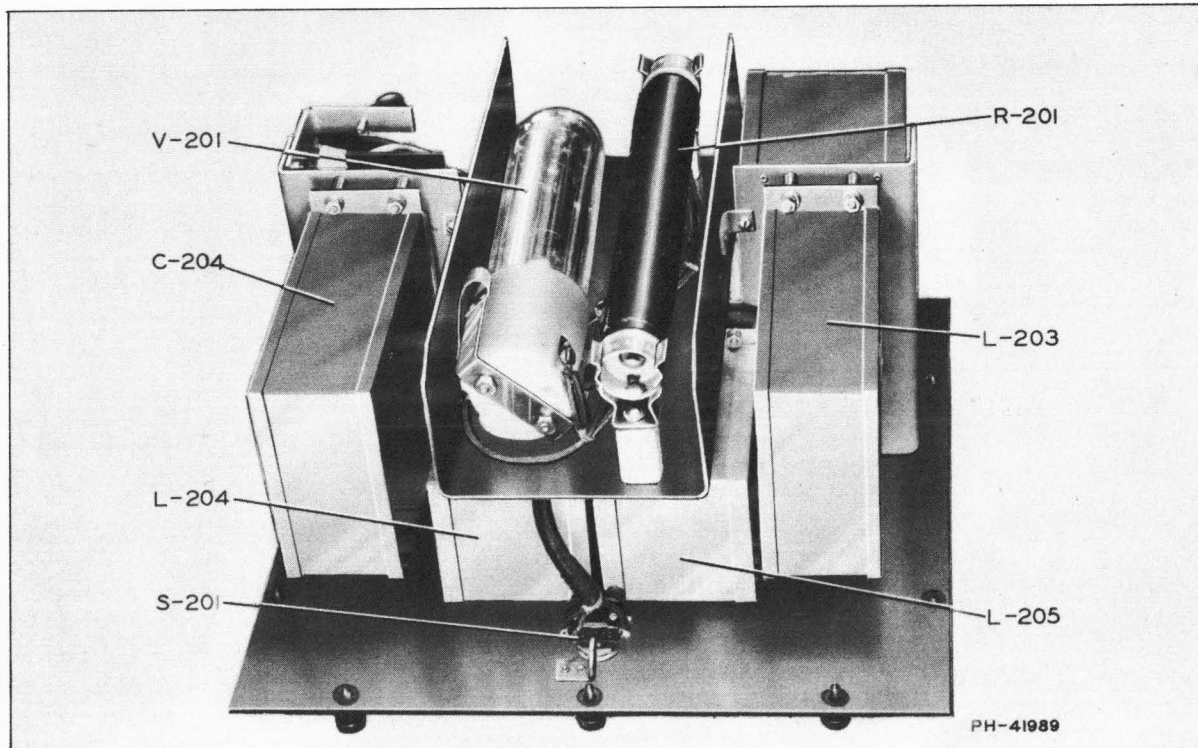

Figure 7—Power Unit CRV-20131 (Bottom View of Chassis)



- 9.5-5 A power switch is provided on the front panel of this unit for turning the equipment on and off when no control unit is employed.
- 9.5-6 In order to make this power unit interchangeable with the one used in the RAK Series equipment, provision is made for the elimination of the current-regulator tube (Type -876) from the circuit when the power unit is used with the RAK equipment. Since the latter receiver operates at relatively low frequencies, the additional freedom from effect of line voltage variation obtained from the current-regulator tube is not needed if the line regulation is within  $\pm 10$  per cent. In the interest of conserving primary supply current, its use with the RAK Series equipment is not recommended under normal circumstances. It must, however, be used with the RAL Series equipment. A switch, therefore, is provided inside the unit to permit operation with or without this tube. (See Figures 1 and 4.) This switch connects the current-regulator tube and switches the power transformer primary for operation in series with the current-regulator tube or directly connected to the line filter. (See paragraph 10.2-3.)
- 9.5-7 Referring to Figure 16, it will be observed that four terminals are provided for connecting the 110-, 115-, or 120-volt, 60-cycle supply to the power unit. When this equipment is used with the control unit, the power connection from the control unit to the power unit is made to the two right-hand terminals. When no control unit is employed, the connection is made to the left-hand terminals. Connecting to the two right-hand terminals removes the power switch on the panel from the circuit. (See Figure 4.)
- 9.6 Control Unit CRV-23073 (see Figure 5) is shown schematically in Figure 19. The use of this control unit makes possible the guarding of two channels simultaneously. The output of each receiver feeds into the control unit where a 3-position switch is provided which makes available, in the two headphone jacks, signals from either or both of the receivers. Two power switches also are provided on the control unit panel for controlling the power to each receiver independently. The a-c power supply feeds into the control unit and each side of the line is fused. The two supply cables connect to suitable terminals on the power units, which terminals are arranged to omit from the circuit the switch and the fuses in the power unit.
- 9.7 In order to reduce interference from neighboring transmitters several filter circuits have been introduced as follows:
- 9.7-1 For reduction of U.H.F. interference, a choke coil (L118) is connected between the antenna terminal and a terminating ceramic spacer. Normally, this choke coil is shunted by a bus; this bus should be cut if interference is reduced by temporarily disconnecting the antenna.
- 9.7-2 A filter assembly connected to the output jack J101 and consisting of coils L117A and L117B and by-pass capacitors C147 and C148 eliminates signal pick-up on the phone leads. The shield around the phone jack prevents direct radiation from the jack itself. See Figure 6.
- 9.7-3 An output cable filter assembly consisting of series coils L115 and L116 and by-pass capacitors C145 and C146 prevents signal pick-up on the phone leads and output cable connecting the control box to the receiver. It is mounted in a shielding can which prevents any direct radiation when assembled inside the receiver cabinet. This filter unit is mounted in the cabinet and is illustrated in Figure 2.
- 9.7-4 A grounding wiper is provided for the main tuning shaft to reduce radiation inside of the receiver.
- 9.7-5 Grounding clamps are provided on the receiver and power supply cases for grounding the braided shielding of the output and power supply cables. (W101 and W201.)

## X

### OPERATION

#### 10.1 Controls of Receiver Unit CRV-46156.

- 10.1-1 "Antenna," "Common" and "Ground" Binding Posts: The antenna should normally be connected to the post marked "Antenna" except when it is necessary to operate this receiving equipment on an antenna in common with an RAK Series Receiving Equipment. In the latter case, the antenna should be connected to the binding post marked "Common." See "ANTENNA REQUIREMENTS," Section V.

- 10.1-2 "FREQUENCY BAND" Selector Control: This control serves as a means for changing the required inductance for the various radio-frequency bands. The switch pointer should be set on the band number falling between the frequencies which establish the desired frequency range. Frequencies are marked in megacycles.
- 10.1-3 "TUNING" Control: The tuning control varies the setting of the three-gang variable tuning condenser. The scale increases with frequency.
- 10.1-4 "ANTENNA TRIMMER" Control: This controls a variable trimmer capacitor for the antenna tuning stage (1st r-f grid circuit). In general, it is adjusted once for each band, preferably at the high-frequency end.
- 10.1-5 "RF TRIMMER" Control: This controls a variable trimmer capacitor for the second r-f tuned grid circuit. In general, it is adjusted once for each band, preferably at the high-frequency end.
- 10.1-6 "FREQ. VERNIER" Control: This control is a very small trimmer capacitor connected in the autodyne detector tuned circuit to obtain small variations in audio beat-note. The panel scale is zero at the center. Calibration and tuning are normally accomplished with the "Freq. Vernier" set at zero.
- 10.1-7 "FIL. VOLTS" Meter: The filament voltmeter indicates when the power is turned "On" and should read approximately 6 volts when the equipment is operating properly.
- 10.1-8 "AVC OFF-ON" Switch: This switch when in the "On" position, places the automatic volume control in operation; when in the "Off" position, it disconnects the automatic volume control. The automatic volume control is *not* intended for use on voice modulated signals.
- 10.1-9 "AVC LEVEL" Control: This control varies the bias on the AVC tube and thereby sets the volume level when the "AVC Off-On" switch is in the "On" position.
- 10.1-10 "REGENERATION" Control: This control varies the screen-grid potential of the autodyne detector, thus regulating the degree of feedback required for oscillation.
- 10.1-11 "SENSITIVITY" Control: This control varies the cathode potential of the two r-f tubes with respect to their grid potentials.
- 10.1-12 "AUDIO TUNING" Control: This 10-position switch selects the proper inductance in the audio-frequency variable attenuator circuit to permit this circuit to pass frequencies in the range of 450 to 770 or 770 to 1300 cycles depending upon the position of the audio tuning range switch (see 10.1-14). The switch positions are numbered to increase with respect to frequency.
- 10.1-13 Audio Tuning "OFF-ON" Switch: This switch places the audio-frequency variable attenuator in or out of the circuit.
- 10.1-14 Audio Tuning "450-770" or "770-1300" Switch: This switch selects the range of frequency in cycles in which the 10-position "Audio Tuning" control is operable.
- 10.1-15 "AUDIO BROAD-SHARP" Switch: This control places a low-pass filter in the audio circuit directly following the detector when the switch is placed in the "Sharp" position and removes the filter from the circuit when the switch is placed in the "Broad" position.
- 10.1-16 "OUTPUT" Meter: This rectifier type a-c meter indicates the audio-frequency output level delivered to the headphones. It is calibrated in decibels above and below zero level, which is 6 milliwatts of audio output.
- 10.1-17 "ADD DECIBELS" Switch: This range switch is used to read "Add Decibels" (algebraically) in connection with the "Output" meter. Five positions are provided: "Off," "15," "10," "5," and "0" in a clockwise direction.
- 10.1-18 "OSC. TEST" Button: This push button is connected from the detector cathode to ground. When it is depressed, it stops the detector from oscillating and produces a definite double click in the headphones. In many cases, the detector enters and leaves oscillation so gradually that it is necessary to use this button in order to determine whether or not the detector is oscillating.

- 10.1-19 "DC POWER OFF-ON" Switch: This switch is not used in the normal operation of this equipment and is accordingly wired out of the circuit by short-circuiting links located under the chassis (see Figure 6).
- NOTE:** HOWEVER, SHOULD OCCASION ARISE, THIS EQUIPMENT MAY BE OPERATED FROM A BATTERY SUPPLY CONSISTING OF SUITABLE FILAMENT AND PLATE BATTERIES. THIS METHOD OF OPERATION WILL REQUIRE OPENING OF THE SHORT CIRCUITING LINKS (SEE FIGURES 6 AND 20), AND CONNECTION OF CABLE W-201 AS INDICATED BY THE DOTTED LINES IN FIGURE 16. OPERATION OF THE RECEIVER WILL THEN BE CONTROLLED BY THE "DC POWER" SWITCH ON THE FRONT PANEL.
- 10.1-20 "PHONES" Jack: This jack provides termination for a pair of low-impedance (600-ohm) headphones.
- 10.2 Controls of Power Unit CRV-20131.
- 10.2-1 "OFF-ON" Switch: This switch located on the front panel controls all power to the power unit when not used in conjunction with a control unit.
- 10.2-2 Reference to Figure 16 shows that when the power unit is used in conjunction with the control unit, connection is made to the right-hand input terminals of the power unit. With this connection, the panel switch and the power unit fuses are disconnected from the circuit.
- 10.2-3 Current Regulator Switch: This switch is located under a terminal board at the right rear top of the chassis (see Figures 1 and 4) and should be thrown to the "In" position for this equipment. In this position, the proper primary connections to the transformer are made for operation with current regulation.
- 10.3 Controls of Control Unit CRV-23073.
- 10.3-1 For operation of Receiver No. 1, place the switch "On-Off 1" in the "On" position, the "1"- "mixed"- "2" switch in the "1" position and the "On-Off 2" switch in the "Off" position. The headphones should be plugged into one of the phone jacks on the control unit.
- 10.3-2 For operation of Receiver No. 2, proceed as in 10.3-1 above except that all switches should be thrown to the "2" position.
- 10.3-3 For simultaneous monitoring of the output from two receivers, both No. 1 and No. 2 "On-Off" switches should be placed in the "On" position and the "1"- "mixed"- "2" switch should be placed in the "mixed" position. The headphones should be plugged into one of the jacks on the Control Unit. The phone jacks on the receiver units are not controlled by the "1"- "mixed"- "2" switch. Two phone jacks are provided to permit simultaneous monitoring or operation by two operators.
- 10.4 CW Reception
- 10.4-1 To apply power to the equipment, the proper "Off-On" switch should be thrown to the "On" position. The filament voltmeter should indicate approximately 6 volts. Allow sufficient time for the tube heaters to reach their operating temperature. This time will probably be not less than 30 seconds.
- (a) When using a single RAL Series equipment, the "Off-On" switch on the power unit controls the power to the receiver.
- (b) When using this equipment in combination with an RAK Series equipment, the proper "On-Off" switch on the control unit controls the power to the desired receiver.
- 10.4-2 To receive a signal whose frequency is known, throw the Audio Tuning and AVC "Off-On" switches to the "Off" position and the "Audio Broad-Sharp" switch to the "Broad" position and set the "Freq. Vernier" on zero.
- 10.4-3 Set the "Frequency Band" switch to the band number corresponding to the frequency range which includes the frequency of the station desired.
- 10.4-4 The "Tuning" control should be set to the desired frequency by reference to the calibration chart and the "Sensitivity" control should be advanced until a perceptible noise level is obtained. The "Antenna Trimmer" and the "R-F Trimmer" should be adjusted for *maximum* noise output.

**CAUTION: KEEP "SENSITIVITY" CONTROL RETARDED.** Due to the high degree of sensitivity incorporated in the equipment, the "Sensitivity" control can only be used near maximum under ideal conditions of low external noise level. For ordinary operating conditions, it is necessary to retard the "Sensitivity" control in order to avoid OVERLOADING THE RECEIVER WITH NOISE and masking the desired signal.

- 10.4-5 The "Regeneration" control should be set so that the detector is oscillating as evidenced by a double click heard in the headphones when the "Osc. Test" button is pressed and released.
- 10.4-6 The "Tuning" control should now be adjusted until the desired signal is heard and finally set to produce as near a 1000-cycle beat note as possible. Finally, adjust the "Antenna Trimmer" and "R-F Trimmer" for maximum signal.
- 10.4-7 Fine adjustment of beat note may now be obtained by the use of the "Freq. Vernier" control and this control may be used to follow transmitter or receiver drift.
- 10.4-8 In cases where the frequency of the signal is not known (such as when searching), excellent advantage may be taken of the uni-control feature, exercising care to keep the "Sensitivity" control at such a point as not to overload the receiver with noise.
- 10.4-9 The "AVC Level" control will maintain a substantially constant output signal level for wide fluctuation in the field intensity of the received signal. It materially assists in copying signals through heavy static because the static peaks are held to such a low value that the operator's attention is not distracted from copying the signals. To utilize this control, advance the "Sensitivity" control until the noise level is perceptible (not in excess of -10 db), then throw the "AVC Off-On" switch to the "On" position and adjust the "AVC Level" control until a copyable signal is obtained.  
**NOTE: TO USE THE "AVC LEVEL" CONTROL TO BEST ADVANTAGE, THE SIGNAL SHOULD BE HELD TO AS LOW A VALUE AS WILL PERMIT GOOD COPY.**
- 10.4-10 Throwing the Audio Tuning "Off-On" switch to the "On" position will result in increased selectivity and reduced noise level permitting of improved reception. The desired signal may be tuned to produce any beat note within the range of 450 to 1300 cycles and audio tuning adjusted to produce a maximum response at this beat frequency. It will often be found easier to set the Audio Tuning to a desired frequency, such as 1000 cycles, and to adjust the CW beat note to this frequency by the Frequency Vernier, rather than to adjust the Audio Tuning to the beat frequency. The following table shows an approximate calibration of the audio tuning:

**TABLE No. 1—AUDIO TUNING**

<i>Audio Tuning Switch 450-770</i>			<i>Audio Tuning Switch 770-1300</i>		
Tap	1—	450 cycles	Tap	1—	800 cycles
"	2—	475 "	"	2—	845 "
"	3—	500 "	"	3—	890 "
"	4—	530 "	"	4—	940 "
"	5—	565 "	"	5—	990 "
"	6—	600 "	"	6—	1040 "
"	7—	640 "	"	7—	1100 "
"	8—	680 "	"	8—	1160 "
"	9—	725 "	"	9—	1225 "
"	10—	770 "	"	10—	1300 "

- 10.4-11 Throwing the "Audio Broad-Sharp" switch to the "Sharp" position will result in increased selectivity and an improved signal-to-noise ratio. This filter accepts signals up to 1200 cycles and rejects signals above 1600 cycles.

**10.5 ICW or Modulated Signal Reception:**

- 10.5-1 The procedure is the same as outlined above with the exception that the "Regeneration" control should be maintained slightly below the setting which produces oscillation. There should not be a pronounced double click as the "Osc. Test" button is pressed.
- 10.5-2 Particularly on the higher frequencies, a considerable improvement in both sensitivity and selectivity results when the "Regeneration" control is set reasonably near but below the condition of oscillation.

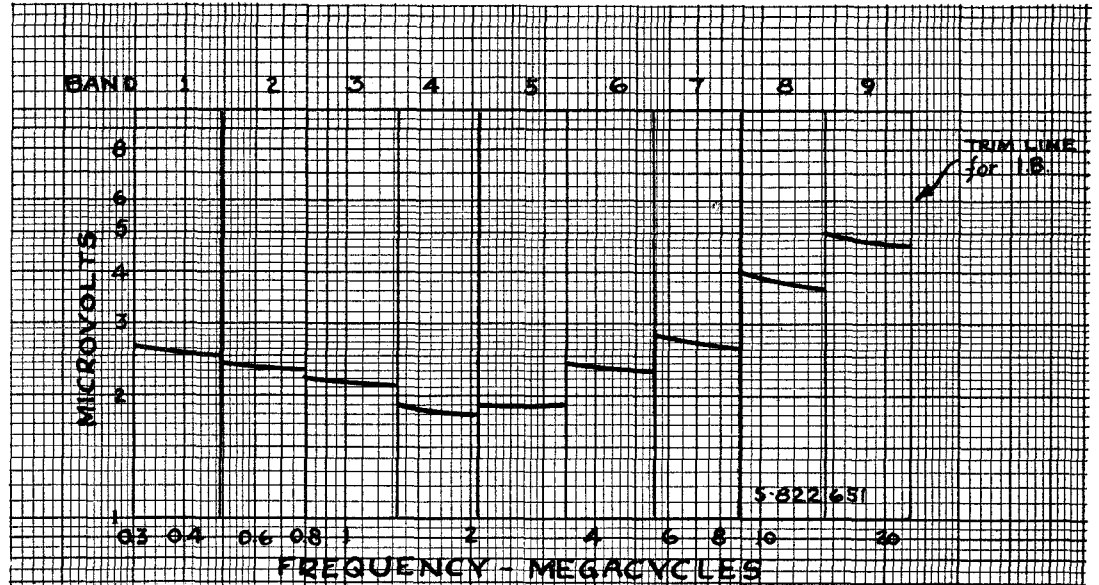

Figure 8—Sensitivity (microvolts for 6/05 M.W. Signal/Noise Ratio)

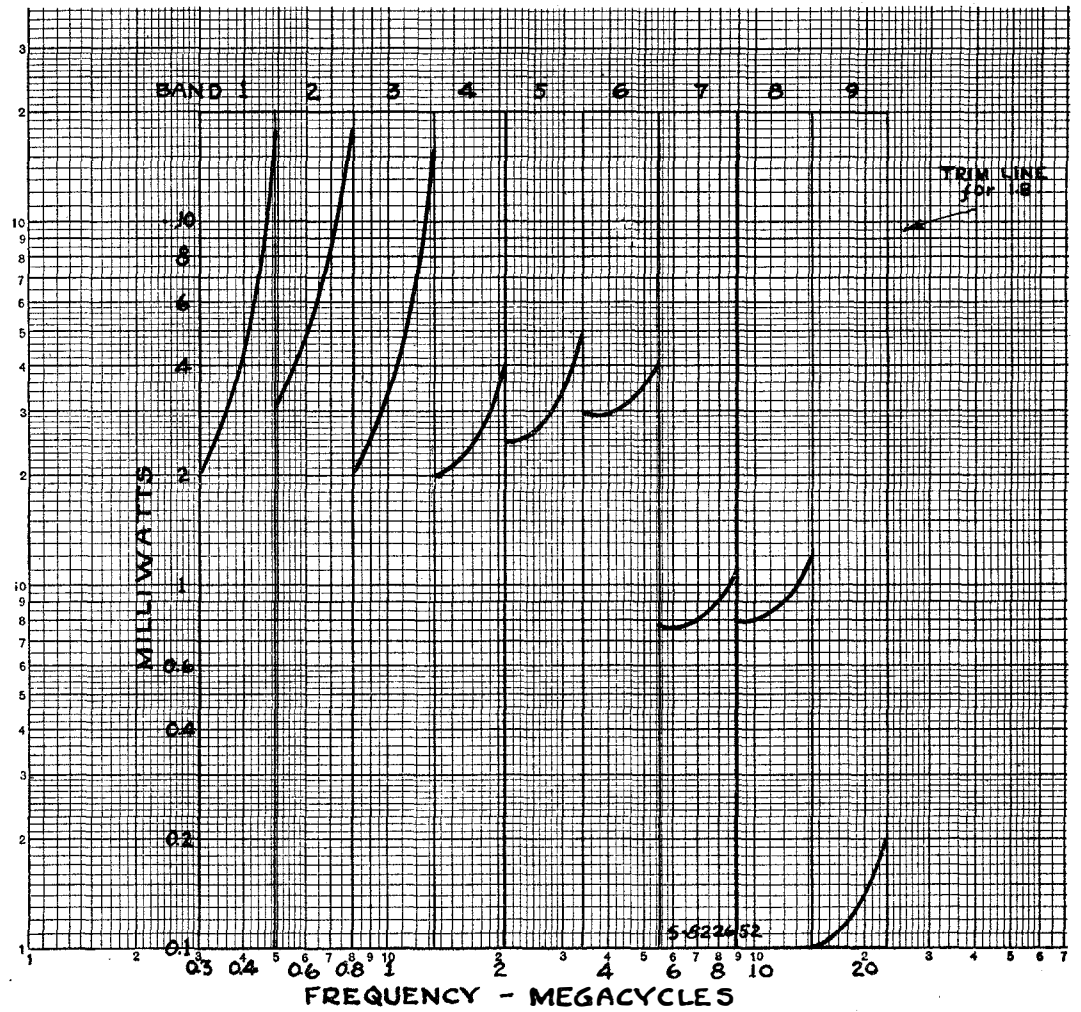

Figure 9—Maximum Noise

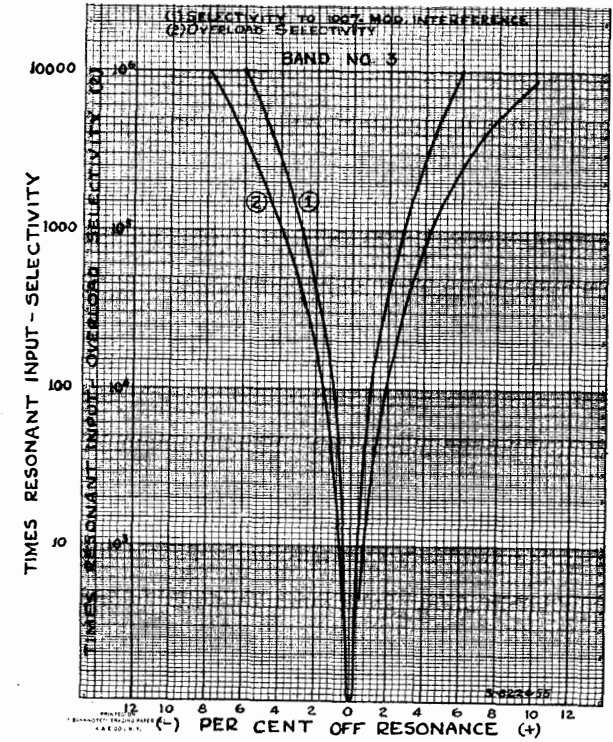
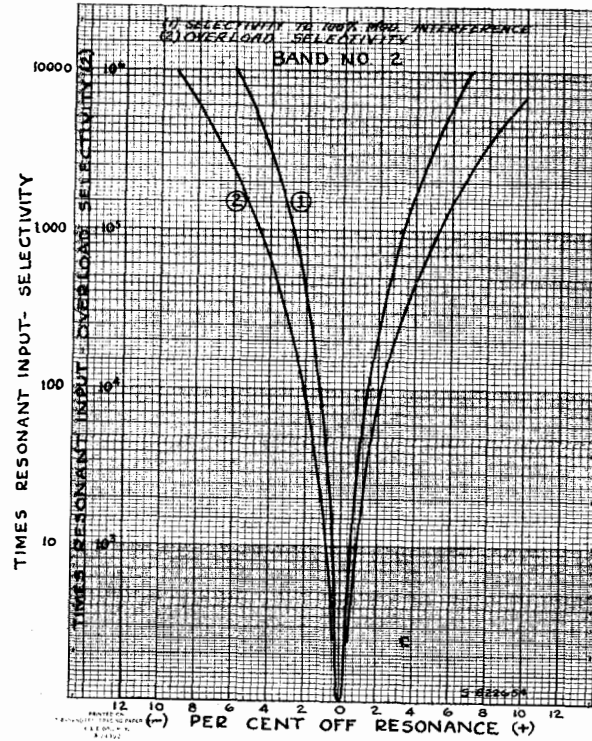
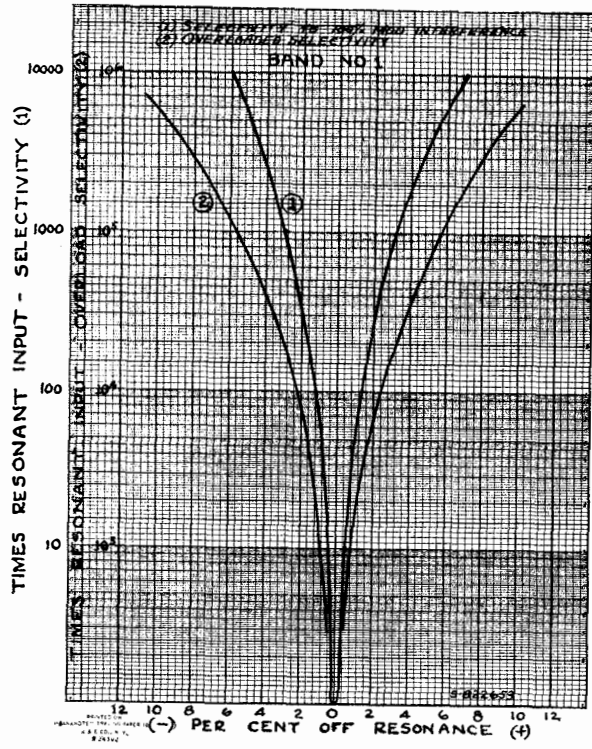

Figure 10—Average Selectivity and Overload Selectivity—Bands 1, 2 and 3

(1) Selectivity to 100% Mod. Interference; (2) Overload Selectivity



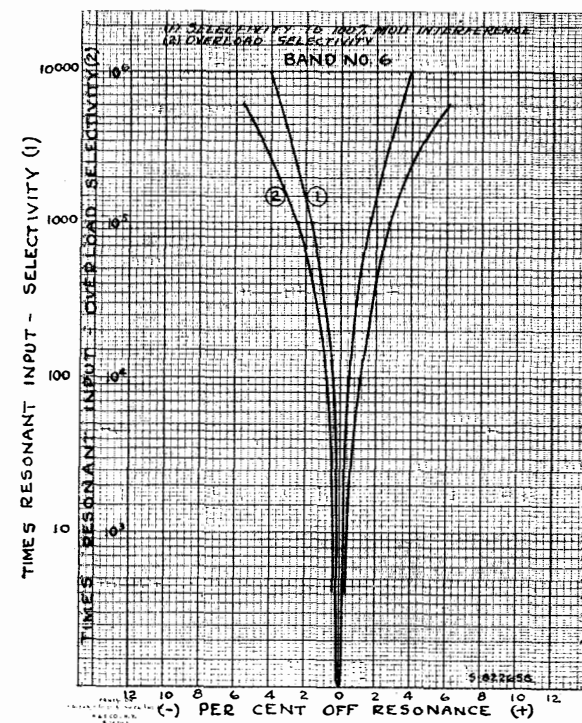
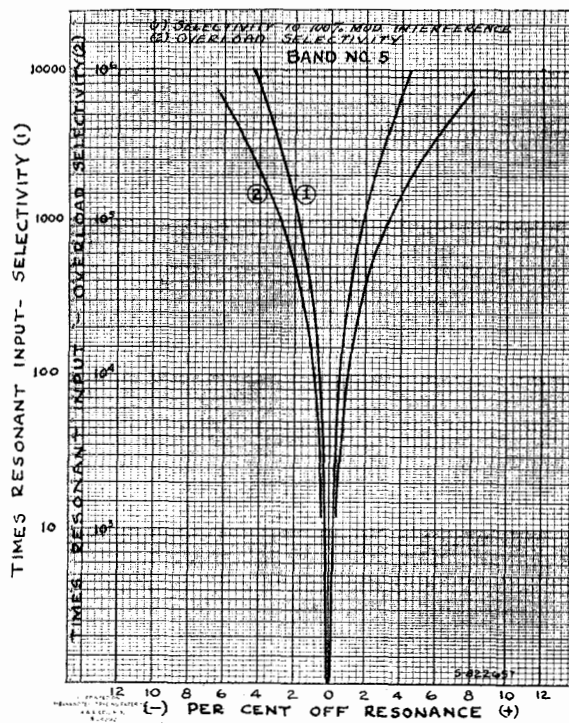
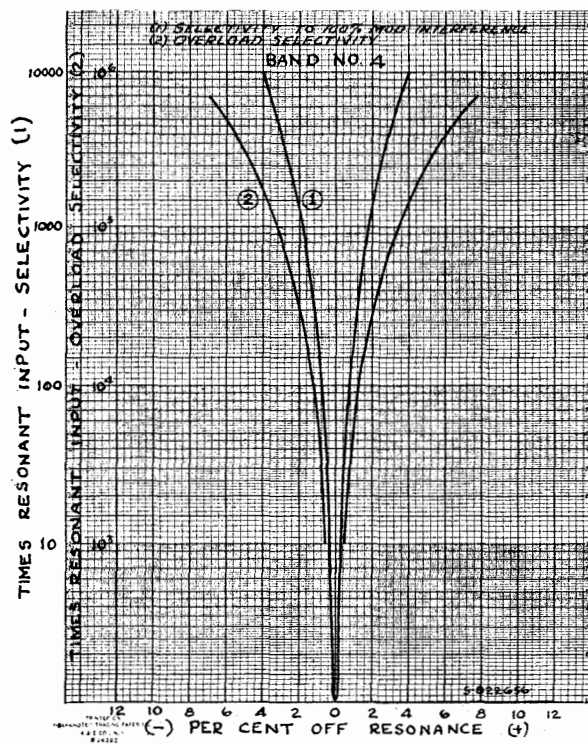

Figure 11—Average Selectivity and Overload Selectivity—Bands 4, 5 and 6  
(1) Selectivity to 100% Mod. Interference; (2) Overload Selectivity

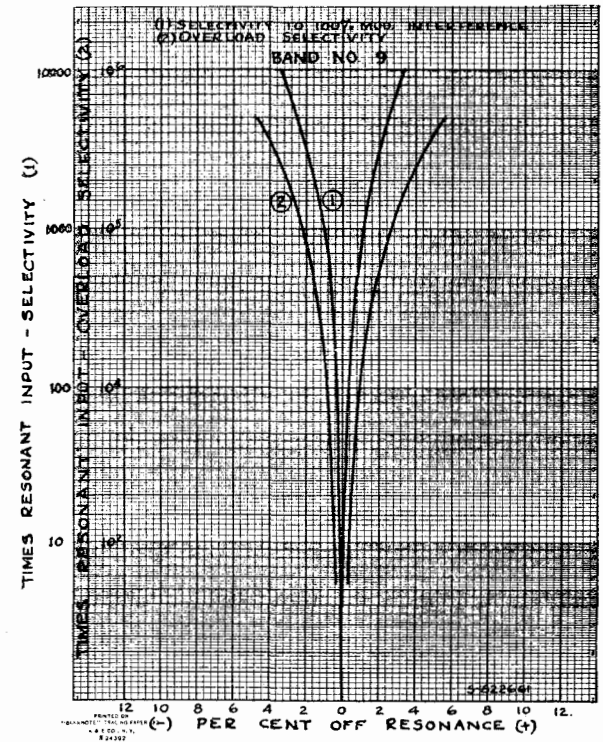
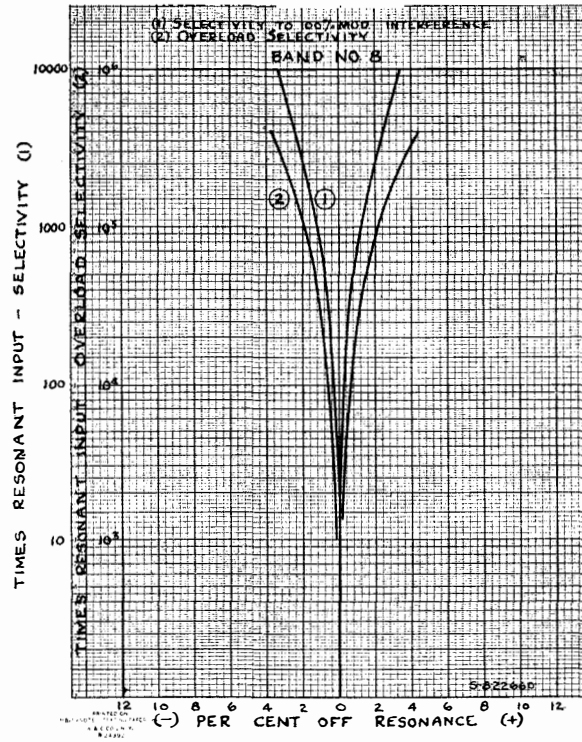
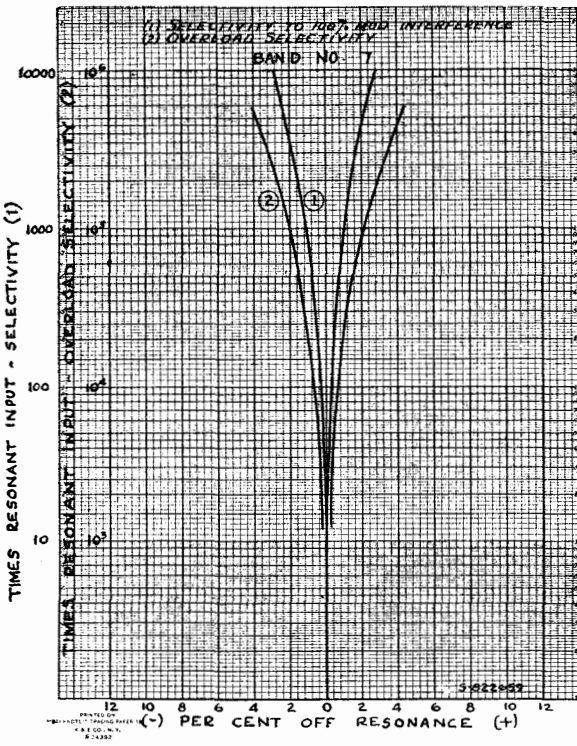

Figure 12—Average Selectivity and Overload Selectivity—Bands 7, 8 and 9  
 (1) Selectivity to 100% Mod. Interference; (2) Overload Selectivity



- 10.5-3 The low-pass filter does not respond to frequencies appreciably higher than 1200 cycles which is inadequate for the proper reproduction of speech. The frequency characteristic of the "Audio Tuning" circuits is such as to be inadequate for the proper reception of speech.
- 10.5-4 When receiving ICW, the "Audio Tuning" may be used for the reception of a 450 to 1300-cycle modulated signal and the Audio Tuning "Off-On" switch should be thrown to the "Off" position except for this condition.
- 10.5-5 When receiving ICW, the "Audio-Sharp" condition may be used provided the frequency of modulation lies in the range of 250 to 1200 cycles.

## XI

### PERFORMANCE

#### 11.1 Sensitivity

11.1-1 Figure 8 gives approximate normal sensitivities for the various bands. The procedure and conditions of measurement are as follows: With "AVC-Off", "Audio-Broad", "Audio Tuning-Off", and with a 600-ohm non-inductive resistance at receiver output terminals, pure CW is applied from a signal generator to the receiver input through a 300-ohm non-inductive dummy antenna resistance. The output beat note is held at 1000 cycles (receiver tuned 1 kilocycle higher than signal). The regeneration control is set at standard oscillation (increased beyond critical oscillation to the point where the output drops 3 db or from 2.68 V. in 600 ohms at critical oscillation to 1.9 V. at standard oscillation). The "Sensitivity" control is set for 50 micro-watts (0.173 V. in 600 ohms) noise output with no signal input. The microvolts input then required to produce 6 mw output (1.9 V. in 600 ohms) is measured.

**NOTE:** THE CRITICAL OSCILLATION POINT IS THAT ADJUSTMENT OF THE "REGENERATION" CONTROL PRODUCING THE MOST FEEBLE OSCILLATIONS, RESULTING IN MAXIMUM OUTPUT. THIS CONDITION IS USUALLY TOO CRITICAL TO EMPLOY AS AN OPERATING ADJUSTMENT BUT IS A REFERENCE SETTING FOR STANDARD AND MEASUREMENT COMPARISON.

11.1-2 It is to be expected that the sensitivity will vary from time to time due to atmospheric conditions, tube characteristics, external noise conditions, etc., so that unless the sensitivity is definitely low (as indicated by high input microvolts) no attempt should be made to improve performance.

#### 11.2 Maximum Noise

11.2-1 Figure 9 shows approximate values of maximum receiver noise level for the various bands. This data will be found useful for a rough check on sensitivity. The method of measurement is to adjust the receiver as for sensitivity (see 11.1), switch off signal generator, increase "Sensitivity" control to maximum and measure output noise voltage. The measured values of noise may be expected to vary considerably due to atmospheric conditions, tube characteristics, external noise conditions, etc., so that unless the noise output is definitely low, no attempt should be made to improve performance and, in any case, the sensitivity should first be accurately checked as explained in Section 11.1.

11.2-2 If measuring equipment is not available, an approximate measurement may be made by adjusting the "Regeneration" control to critical oscillation and all other controls for maximum noise output. The antenna terminal should be connected to ground through a 300-ohm resistor preferably inside the receiver cabinet (to eliminate external noise pickup). In this case, the noise output should be approximately 3 db higher than the values shown in Figure 9. (This is twice the value of milliwatts shown therein.)

#### 11.3 Selectivity and Overload Selectivity

11.3-1 Figures 10, 11 and 12 show Selectivity and Overload ratios for each band. Curves (1) show the selectivity to 100% modulated interference when the receiver is operated for CW reception. They correspond closely with actual conditions at the middle of the band and represent an average for the band. These data are taken by first adjusting the receiver as for sensitivity measurement (par. 11.1) with 6 mw output at resonance. The signal is then modulated 30% and the frequency varied. The ratios of inputs off resonance (required to produce 6 mw output) to the normal (resonant) input are noted and the data corrected by multiplying by 3.33 to simulate 100% modulated interference.

11.3-2 Curves (2) of Figures 10, 11, and 12 show the overload selectivity characteristics for each band. These curves correspond closely with actual conditions at the middle of the band and represent an average for the band. This data is taken by first adjusting the receiver as for sensitivity measurement (par. 11.1). With the resonant signal being received, a CW interfering signal is applied at various frequencies off resonance and the ratios of inputs off resonance (required to reduce the resonant signal output by 3 db) to the normal (resonant) input are noted.

#### 11.4 Calibration

11.4-1 Figure 13 shows average frequency calibration curves and band coverage of this equipment. Table No. 2 gives the nominal frequency range of each band.

**TABLE No. 2**

<i>Band</i>	<i>Frequency Range (Megacycles)</i>
1	0.3 — 0.49
2	0.49 — 0.8
3	0.8 — 1.33
4	1.33 — 2.08
5	2.08 — 3.4
6	3.4 — 5.5
7	5.5 — 8.8
8	8.8 — 14.3
9	14.3 — 23.0

## XII

### MAINTENANCE—TROUBLE LOCATION AND REMEDY

#### 12.1 General

12.1-1 This equipment has been carefully adjusted at the factory for optimum performance and is designed to maintain this adjustment for long periods of time. If any major adjustments or repairs become necessary, it is recommended that such adjustments and repairs be made in a well equipped laboratory where the proper tools and measuring equipment are available. Before making any changes in receiver adjustment, it should be definitely ascertained that the difficulty being experienced is not the result of external or normal deteriorating influences such as worn out vacuum tubes, improper operating voltages, blown fuses, external noises, etc.

**IN TESTING OR INSPECTING CIRCUITS IN THIS EQUIPMENT, CARE MUST BE EXERCISED NOT TO DISARRANGE R-F WIRING.**

#### 12.2 Equipment

12.2-1 Where standard laboratory equipment is not available, the following equipment is recommended for use in locating troubles.

12.2-2 Radio Receiver Analyzing Equipment, Model OE (or equivalent), consisting of one Type 22193 DC Voltmeter/Milliammeter/Ohmmeter; one Type 22194 AC Voltmeter/Capacity Meter; one Type 60001 Vacuum Tube Circuit Selector Unit.

12.2-3 Calibrated Test Oscillator, Model LN (or equivalent) — frequency range 0.3 to 23 megacycles.

#### 12.3 Dead Receiver.

12.3-1 With "AVC-Off," "Audio Tuning-Off," "Audio-Broad" and "Sensitivity" control at maximum, increase the "Regeneration" control setting from minimum to maximum, depressing the "Osc. Test" button at intervals. If no clicks or noise outputs are heard in the phones on any band, the following procedure may be followed for location of trouble.

12.3-2 Check the vacuum tubes, particularly the detector tube.

12.3-3 Check the power supply (see 12.10).

12.3-4 Test the headphones and the output circuit wiring for short- or open-circuits.

12.3-5 Test the audio amplifier (see 12.11).

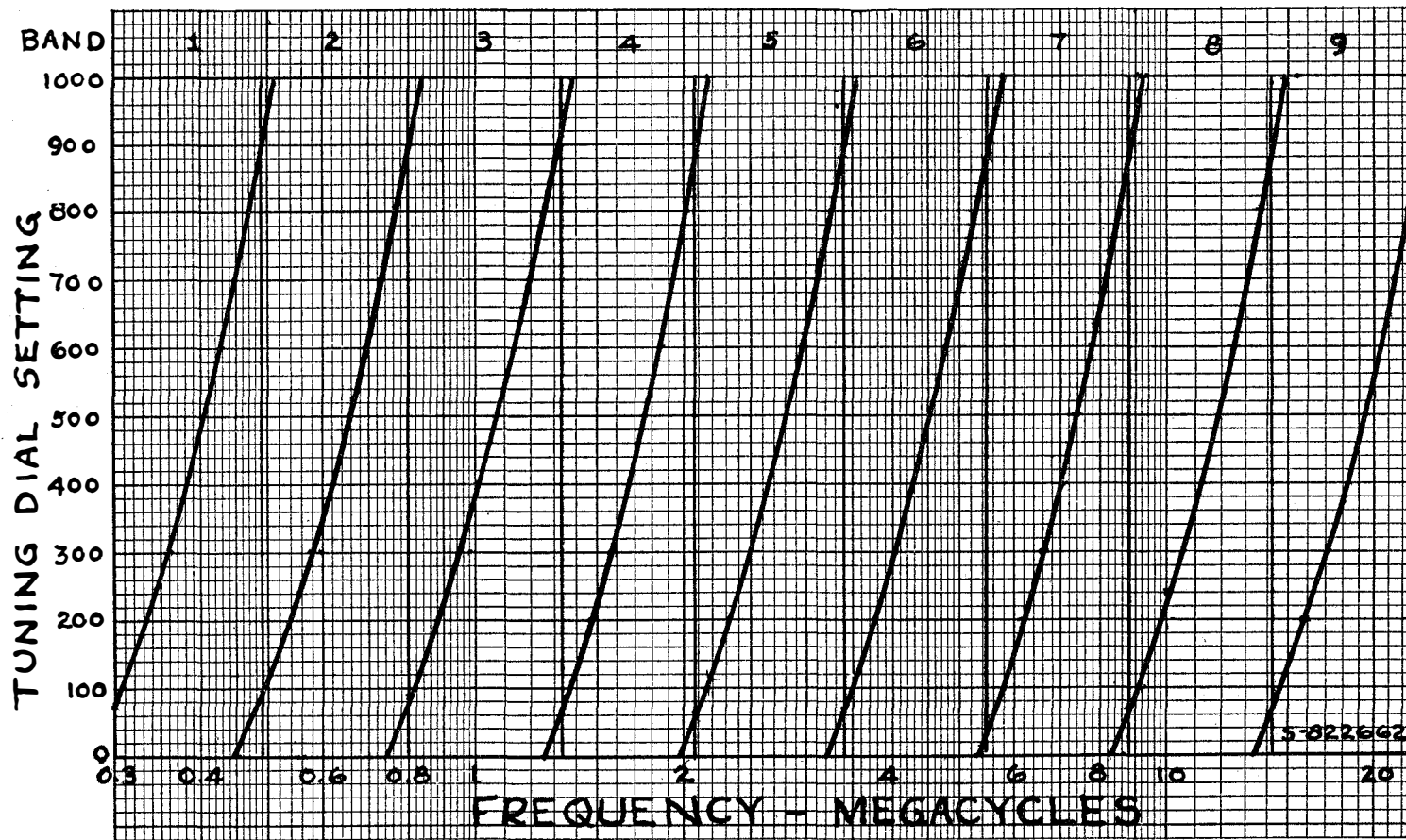

Figure 13—Average Frequency Calibration Curves

- 12.4 Weak Signals with Receiver Noise Level Normal.
- 12.4-1 If the receiver operates in a normal manner as indicated by the characteristic noise output (see 11.2) and no signals are in evidence, inspect the external antenna circuit.
  - 12.4-2 Withdraw the receiver partially from the cabinet and inspect the antenna connections.
- 12.5 Weak Signals with Detector Failing to Oscillate on All Bands.
- 12.5-1 With "AVC-Off," "Audio Tuning-Off" and "Audio-Broad," set the "Sensitivity" control at maximum, advance the "Regeneration" control and depress the "Osc. Test" button, noting whether the detector oscillates. If the detector fails to oscillate or oscillates with the "Regeneration" control near maximum on all bands, the following procedure should be followed:
    - 12.5-2 Check the power supply (see 12.10).
    - 12.5-3 Test the detector tube (see 12.13).
    - 12.5-4 Test the detector tube socket voltages (see 12.14).
    - 12.5-5 Test the detector circuit wiring (see 12.15).
    - 12.5-6 Test the switch contacts (see 12.16).
- 12.6 Weak Signals with Detector Oscillating Normally.
- 12.6-1 Test the power supply (see 12.10).
  - 12.6-2 Test the tubes (see 12.13).
  - 12.6-3 If the power supply and the tubes are satisfactory and the receiver noise level is definitely low (see 11.2), the trouble may be located in the output circuit, audio amplifier or r-f amplifier.
  - 12.6-4 Test the output circuit and the headphones for short- and open-circuits. If one side of the output circuit is grounded, the output will be reduced.
  - 12.6-5 Test the audio amplifier (see 12.11).
  - 12.6-6 Test the r-f amplifier (see 12.12).
- 12.7 Failure of Detector to Oscillate on some Bands; Other Bands Normal.
- 12.7-1 If the detector oscillates normally on some of the bands, it may be assumed that the power supply and the tubes are satisfactory and that the trouble is due to faulty band switch contacts or failure in the wiring between the band switch and portion of circuits used in the inoperative bands.
  - 12.7-2 Test the r-f (plate) and detector tube socket voltages, switching the "Frequency Band" switch on and off of the inoperative band (see 12.14).
  - 12.7-3 Test the detector circuit wiring on the inoperative bands (see 12.15).
- 12.8 Weak Signals on Some Bands; Other Bands Normal—Detector Oscillating Normally on All Bands.
- 12.8-1 If normal operation is obtained on part of the bands as indicated by normal receiver noise level (see 11.2), and if the detector oscillates normally on all bands, the trouble is localized in the portion of r-f circuits connecting to the band switch in the weak signal bands.
  - 12.8-2 Test the r-f tube socket voltages, switching the "Frequency Band" switch on and off of the weak signal bands (see 12.14).
  - 12.8-3 Test the r-f circuit wiring on the weak signal bands (see 12.15).
- 12.9 Panel Trimmer Controls.
- 12.9-1 Operation of these controls may be used as an indication of proper functioning of the associated tuned circuits.

- 12.9-2 In general, the setting for maximum response will vary for different bands and, in the case of the "Antenna Trimmer," for different antenna constants. These controls are designed to take care of normal minor variations in receiver alignment which occur over a period of time. A few divisions variation will normally occur over a given band due to slight mismatch of the inductances.
- 12.9-3 Failure of these controls to resonate the circuits, as indicated by maximum response on a signal or maximum noise output on all bands, indicates a defect in the respective circuits. Test the associated tube (see 12.13), tube socket voltages (see 12.14), and circuit continuity (see 12.15).
- 12.9-4 Failure of these controls to resonate the circuits on a particular band (other bands operating normally) indicates defects in the portion of the respective circuits connecting to the band switch on the particular band. Test tube socket voltages (see 12.14), switching the "Frequency Band" switch on and off of the inoperative band. If the voltages and circuit continuity are correct, the receiver alignment should be investigated (see 12.17).
- 12.9-5 An abnormally large change in either trimmer setting over a given band or failure to resonate at only one end of a band indicates that the tuning condenser section or the inductance used in the particular circuit and band has been damaged. If both trimmer settings change in the same direction over a band, this may indicate that the detector tuning condenser or inductance is at fault. (Refer to paragraph 12.17).

#### 12.10 Power Supply.

- 12.10-1 If trouble is traced to the power supply, the following procedure may be followed:
- 12.10-2 Note the receiver panel voltmeter reading. This meter should read approximately 6 V. for normal operation and indicates the filament voltage which is obtained from a winding on the power transformer in the power unit. This also indicates that power is being supplied to the power unit and thus serves as a "power on" indicator.
- 12.10-3 If no voltage is indicated (assuming that the meter is not defective), test the a-c line voltage and fuses in the a-c line, control unit and power unit. Refer to Figure 16.
- 12.10-4 Partially remove the receiver from the cabinet and check the voltage at the power terminal board. Refer to Figure 16. The terminals are numbered from 1 to 9, No. 1 being nearest the panel. These voltages should measure approximately as follows:

**TABLE No. 3—RECEIVER TERMINAL VOLTAGES**

<i>Terminal</i>	<i>Voltage</i>
1 or 9 to 6	180 V. DC
1 or 9 to 5	90 V. DC
2 to 3	5.9 V. AC

- 12.10-5 If the above voltages fail to check, test the a-c power supply voltage. Partially remove the power unit from its case and measure the power unit terminal voltages. Refer to Figure 16. The power unit terminals are numbered from 1 to 6, No. 1 being nearest the panel. These voltages should measure approximately as follows:

**TABLE No. 4**

**POWER UNIT TERMINAL VOLTAGES**

<i>Terminal</i>	<i>Voltage</i>
1 to 5	180 V. DC
1 to 4	90 V. DC
2 to 3	5.9 V. AC

- 12.10-6 If the above voltages fail to check and the line input voltage and fuses are operative, test the power unit tubes (see 12.13).
- 12.10-7 Test the power unit circuits for continuity (see 12.15).

## 12.11 Audio Amplifier.

- 12.11-1 To determine if the audio amplifier is operating, partially withdraw the receiver from the cabinet and touch the grids of the detector and first a-f tubes. Pronounced clicks should be heard in the phones.
- 12.11-2 If the above test indicates a defect in the amplifier circuit with satisfactory power supply (see 12.10) and output circuit connections (see 12.3-3), the audio tubes should be checked (see 12.13) and the audio circuits tested (see 12.15).
- 12.11-3 If in the test of 12.11-1, a pronounced click is obtained when the first audio grid is touched, but touching the detector grid gives no indication, the trouble is located in the portion of the circuit between these two points.
- 12.11-4 If measuring equipment is available, the audio gain may be checked by application of 1000-cycle input to the first audio grid. The input required for zero level (6 milliwatts) output should be approximately 0.015 volt.

## 12.12 R-F Amplifier.

- 12.12-1 A defective r-f amplifier may be detected by abnormal operation of the trimmer controls (see 12.9), "Sensitivity" control, or by first ascertaining that the remainder of the circuit is operative.
- 12.12-2 With the "Sensitivity" control at minimum, a barely audible hum should be noted and it should be possible to hear the detector go into oscillation if the "Regeneration" control is advanced rapidly. With the detector oscillating, the characteristic double click should be heard when the "Osc. Test" button is depressed. Further tests indicating normal operation of detector output and audio amplifier circuits are noted under 12.11.
- 12.12-3 If a fault is located in the r-f amplifier by the above methods with normal power supply (see 12.10) and antenna connections (see 12.4-2), it should be determined whether the trouble exists on all bands or on only one or more particular bands.
- 12.12-4 If the trimmer operation is not normal, refer to paragraph 12.9.
- 12.12-5 If the trimmer operation is normal and low sensitivity as indicated by the tests outlined in paragraph 11.1 is obtained on all bands, test the r-f amplifier tubes (see 12.13), socket voltages (see 12.14) and circuit continuity (see 12.15).
- 12.12-6 If trouble is located on a particular band or bands with other bands operating normally, check the socket voltages (see 12.14) and circuit continuity (see 12.15), switching the "Frequency Band" switch on and off of the inoperative band. Check the "Frequency Band" switch (see 12.16).
- 12.12-7 Before making extensive circuit tests, an attempt should be made to localize the trouble in the first or second amplifier stage. This may be done by applying input from a test oscillator to the respective grids.

## 12.13 Tube Characteristics.

- 12.13-1 If trouble is traced to tubes in a portion of the circuit, the trouble may be quickly checked by replacing the doubtful tube with a tube of known characteristics and re-checking the performance of the equipment.
- 12.13-2 Tubes may be tested for open heaters or shorts between elements by use of a continuity meter or click test with the precaution that the rated voltage of the filament is not exceeded.
- 12.13-3 Tubes will be found to deteriorate gradually with use, resulting in a gradual reduction in performance of the equipment. It is therefore advisable to replace tubes after 1000 hours of service or to measure them at regular intervals to determine if the limit of serviceability has been reached. Table No. 5 gives standard characteristics for the tubes used in this equipment and low limits of "emission" and "transconductance." A test of "emission" is usually sufficient to indicate the condition of a tube, but a better correlation between test results and actual conditions is obtained by measurement of "transconductance." Actual operating voltages on the tubes as used in this equipment are appreciably lower than the ratings shown in the table so that extended tube life is assured.

**TABLE No. 5—TUBE CHARACTERISTICS**

Tube Type	Fil. Volts	Fil. Current (Amps.)	Plate Volts	Screen Volts	Grid Bias Volts	Plate Current (MA.)	*Emission Current (MA.)	Screen Current (MA.)	AC Plate Resistance (Ohms)	Ampl. Factor	Average Transcond. (Micromhos)
-6D6	6.3	0.3	250	100	- 3	8.2	100	2.0	800,000	1280	1600
-41	6.3	0.4	250	250	-18	32	200	5.5	68,000	150	2200
-874	..	..	90	..	..	30	..	(striking voltage 125 V.)			*
-876	50	1.7	..	..	..	..	..	..	.....	.....	.....
-5Z3	5.	3.0	..	..	..	..	240	..	.....	.....	.....
-5Z3	(AC voltage per plate 500 RMS—Max. DC Output Current 250 M.A.)										

Tube Type	Low Limits	
	*Emission (MA.)	Transconductance (Micromhos)
-6D6	50	1200
-41	70	1300
-874	..	....
-5Z3	..	....
-5Z3	190	....

\*For "emission" tests, all grids are connected to the plate and are 50 volts positive with respect to the cathode or filament, except the Type -5Z3 tube on which a potential of 40 volts is used with both plates connected together.

12.13-4 Measurement of "emission" and "transconductance" is not always an absolute indication of the condition of tubes for their various applications, particularly in the case of detector tubes and AVC tubes. An unsatisfactory detector tube is best indicated by its oscillating properties. A tube which does not function properly in the detector stage may often be used in an amplifier stage without loss in performance. A low output tube may often be utilized in the AVC position.

**12.14 Tube Socket Voltages.**

12.14-1 Measurement of socket voltages may be used as a check on power supply and receiver circuit connections.

12.14-2 The following table gives average tube socket voltages for this equipment. These voltages are not operating voltages and will vary considerably with different types of voltmeters. The values stated below apply for the Model OE Radio Receiver Analyzing Equipment.

**TABLE No. 6—TUBE SOCKET VOLTAGES**

Due to change in load when one tube is removed, the voltages measured at the tube sockets are somewhat higher than the corresponding voltages of Tables 3 and 4.

*Sensitivity 10  
AVC Off  
Regeneration 10  
Audio Tuning Off  
Audio Broad*

Tube Type	Function	Plate	Screen	Supp.	Cath.	Grid	Heater
-6D6	1st RF	190	90	0	0	0	6
-6D6	2nd RF	175	90	0	0	0	6
-6D6	Detector	150	45	0	0	0	6
-6D6	Audio	185	170	0	0	0	6
-41	Output	200	200	..	0	0	6
-41	AVC	0	0	..	185	0	6

In making the above measurements the receiver should be operated at normal supply voltage and allowed to warm up for approximately 10 minutes before taking readings. Readings are taken by removing one tube at a time and measuring voltages between the socket terminals and ground. Set "AVC Level-10," "AVC-Off," "Regeneration-10" "Sensitivity-10," "Audio Tuning-Off," "Audio Broad." Figure 14 shows socket terminal arrangements.

**TABLE No. 6a—TUBE OPERATING VOLTAGES AND CURRENTS**

Tube	Function	Plate	Plate	Screen	Screen	Cathode	Supp.	Heater	Note	
		E	MA.	E	MA.	E	E	E		
-6D6	1st RF	140	4.5	72	1.2	3-40	3-40	5.8 (AC)	1	
-6D6	2nd RF	80	4.5	72	1.1	3-40	3-40	5.8 (AC)	1	
-6D6	Detector	50-140	0.0-2.5	17-30	0.0-0.4	0	17-30	5.8 (AC)	2	
-6D6	Audio	50	1.2	27	0.3	1.5	1.5	5.8 (AC)		
-41	Output	115	11.0	120	1.75	7.5	—	5.8 (AC)		
-41	AVC	0	0	0	0	180	—	5.8 (AC)	3	
-5Z3	Rectifier	230 AC—from each plate to ground							4.9 (AC)	

The above are average operating voltage and current values as obtained by measurement with a Model OE Radio Receiver Analyzing Equipment. Readings were taken under the following test conditions: Receiving Equipment in normal operative condition, antenna disconnected, line voltage 115, current-regulator tube 1N, "AVC-Off," "Sensitivity" control on 10 (see Note 1), "Regeneration" control on 5 (see Note 2), "Frequency Band" switch on "1," and "Tuning" control on 0-0. DC voltages measured to heater (ground).

Note 1. Cathode to heater voltage varies with position of "Sensitivity" control. Average limits are shown.

Note 2. Detector voltages and currents vary with position of "Regeneration" control. Average limits are shown.

Note 3. Cathode to heater voltage measured with "AVC Level" control at maximum.

For the above measurements with the Model OE Radio Receiver Analyzing Equipment, the lowest possible voltmeter scale should be used, as follows:

Voltages	Meter	Resistance	Voltages	Meter	Resistance
0/1	0/1	20,000	10/25	0/25	500,000
1/2.5	0/2.5	50,000	25/50	0/50	1,000,000
2.5/5	0/5	100,000	50/100	0/100	2,000,000
5/10	0/10	200,000	100/250	0/250	5,000,000

The color code used for bus wiring between the "Frequency Band" switch and coils is shown in the following table:

**TABLE No. 7  
BUS WIRING COLOR CODE**

Ant. and plate leads.....	Red		
Tuned circuit "high".....	White		
Tuned circuit "low" (taps).....	Green		
Det. cathode circuit.....	Blue		
Bands 1	4	7.....	1 dot
2	5	8.....	2 dots
3	6	9.....	3 dots

In cases where a single lead is used for more than one band, the number of dots correspond with the lowest frequency band for which the lead is used.

12.14-3 If trouble exists on a particular band, the tube socket voltages should be measured on both the inoperative band and on an operative band to indicate which portion of the circuit is at fault.

12.14-4 If a source of trouble is localized in a particular portion of the circuit by the above analysis, this portion of the circuit should be tested for continuity and inspected (see 12.15).

**12.15 Circuit Continuity.**

12.15-1 After tracing a fault to a particular portion of the circuit by the foregoing tests, the circuit should be systematically inspected, tested for continuity, short circuits, ground or failure of component parts, with power off. Refer to following drawings:

Diagram	Figure
Receiver Unit Schematic.....	17
Receiver Unit Connection.....	20
Power Unit Schematic.....	18
Power Unit Connection.....	21



12.15-2 If an ohmmeter is available, point-to-point resistance measurements will be useful in locating faults. The following tables indicate the approximate resistances in this equipment.

**TABLE No. 8**  
**RECEIVER UNIT POINT-TO-POINT RESISTANCES**

<i>Points</i>	<i>Resistance</i>	<i>Condition</i>
Terminal No. 6 to 1st RF plate.....	10,000 ohms	
" " 2nd RF plate.....	20,000 ohms	
" " Detector plate.....	30,000 ohms	
" " Audio plate.....	120,000 ohms	
" " Output plate.....	5,125 ohms	"AVC-Off"
" " Output plate.....	4,800 ohms	"AVC-On"
" " AVC cathode.....	0	"AVC Level — 10"
" " AVC cathode.....	9,740	"AVC Level — 0"
" " 1st RF screen.....	18,000 ohms	
" " 2nd RF screen.....	18,000 ohms	
" " 1st AF screen.....	500,000 ohms	
" " Ground.....	9,740 ohms	
Terminal No. 5 to Detector screen.....	28,800 ohms	"Regeneration — 10"

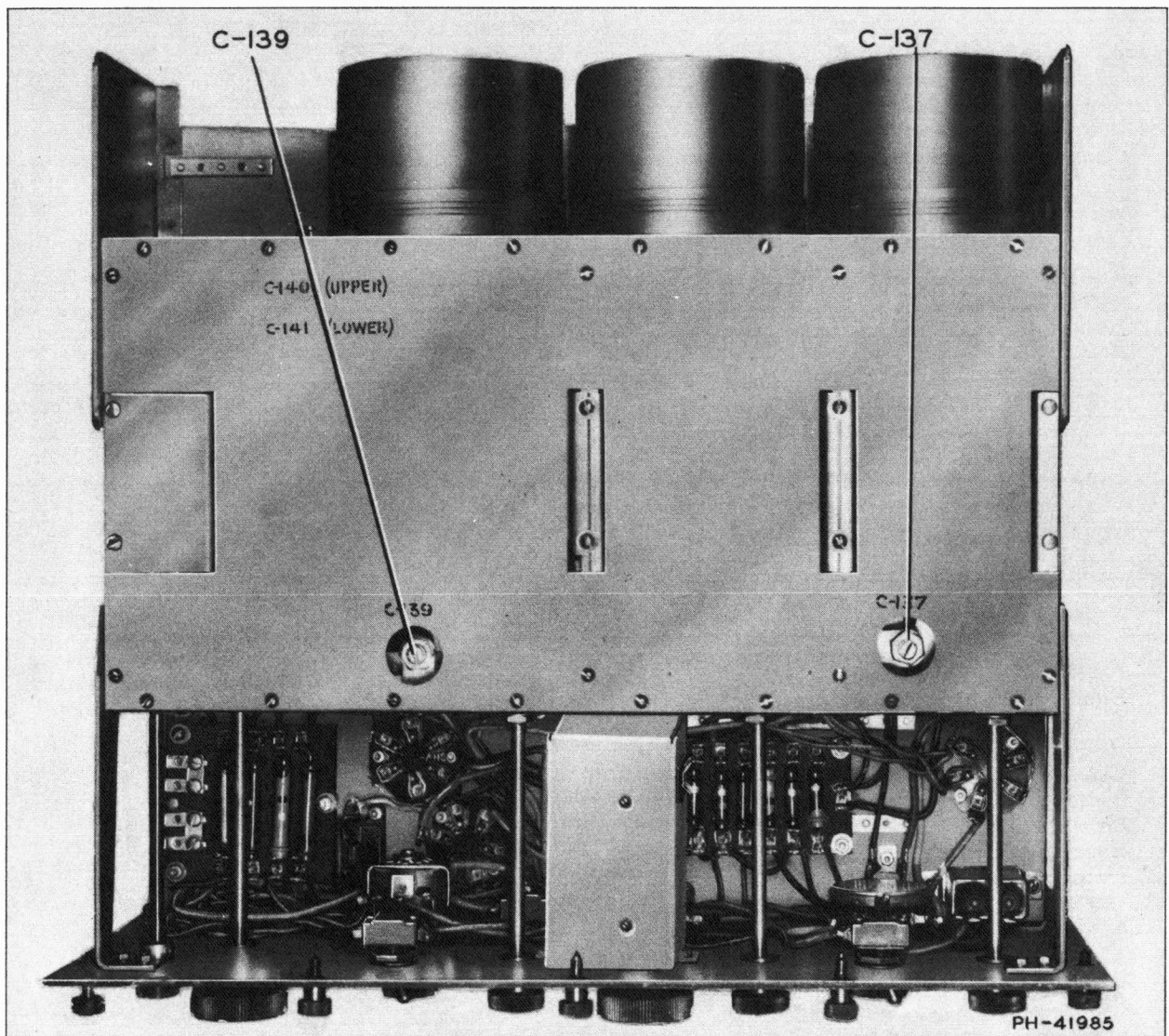

Figure 14—Receiver Unit CRV-46156 (Bottom View of Chassis)

Points	Resistance	Condition
Ground to	Detector screen . . . . . 10,000 ohms	"Regeneration — 0"
" "	1st RF grid . . . . . 110.5	"Frequency Band — 1"
" "	2nd RF grid . . . . . 1.0 megohms	
" "	Detector grid . . . . . 2.2 megohms	
" "	Audio grid . . . . . 100,000 ohms	
" "	Output grid . . . . . 1.0 megohms	
" "	AVC-screen grid plate. 3,500 ohms	
Terminal No. 7 to No. 8 . . . . .	40 ohms	"Add Decibels Off"
Ground to No. 7 . . . . .	20 ohms	"Add Decibels Off"
" " " 8 . . . . .	20 ohms	"Add Decibels Off"

The above values apply for the receiver unit alone—external cables disconnected, all tubes out of sockets, and receiver set on "Frequency Band—1," and "Tuning—0."

12.15-3 Power unit point-to-point resistances are approximately as noted in the following table:

**TABLE No. 9**  
**POWER UNIT POINT-TO-POINT RESISTANCES**

Points	Resistance	Condition
Terminal No. 2 to No. 3 . . . . .	1.0 ohms	
Terminal No. 1 to No. 5 . . . . .	20,000 ohms	
Terminal No. 1 to No. 4 . . . . .	23,000 ohms	
-5Z3 socket (fil. to fil.) . . . . .	0.15 ohms	
-5Z3 socket (plate to plate) . . . . .	250 ohms	
R-H power line terminals . . . . .	Infinite	"On-Off Switch—Off"
R-H power line terminals . . . . .	7.0 ohms	"On-Off Switch—On"
Power terminals to ground . . . . .	Infinite	

Above values apply for the power unit alone (external cables and wiring disconnected) with all tubes in sockets and with current-regulator tube "In" (the condition of operation of the power unit with this equipment).

12.15-4 Component parts may be identified by cross reference from the item numbers in Figures 17 and 18.

12.15-5 Carbon resistors may be identified by color code as follows:

**TABLE No. 10**  
**RMA COLOR CODE FOR RESISTORS**

Color	A 1st Digit	B 2nd Digit	C Ciphers		
Black	.	0	.0		Original Color Arrangement for Axial Leads
Brown	1	1	0		
Red	2	2	00		New Color Arrangement for Axial Leads
Orange	3	3	000		
Yellow	4	4	0000		Standard Color Arrangement for Radial Leads
Green	5	5	00000		
Blue	6	6	000000		
Purple	7	7	0000000		
Grey	8	8	00000000		
White	9	9	.....		

D—Tolerance Code  
 Gold: 5%  
 Silver: 10%  
 Omit: 20%

## 12.16 "Frequency Band" Switch.

- 12.16-1 To inspect the "Frequency Band" switch and circuit connections, the large plate on the bottom of the chassis may be removed. This switch has been carefully aligned at the factory, the four contacts on each section being accurately adjusted for equalized pressure and maximum contact area. Readjustment of the switch should rarely be found necessary.

IF ANY MAJOR REPAIRS ON THE SWITCH ASSEMBLY BE FOUND NECESSARY, SUCH REPAIRS SHOULD BE MADE IN A WELL EQUIPPED LABORATORY SINCE SERIOUS MECHANICAL MISALIGNMENT OF THE CONTACTS OR MISALIGNMENT OF HIGH-FREQUENCY INDUCTANCES DUE TO DERANGEMENT OF R-F WIRING MAY RESULT.

In order to readjust or replace switch parts and for access to switch wiring, it will be necessary to remove the switch retaining brackets mounted inside the switch compartments at the bottom of the chassis. After removal of the large plate on the bottom of the chassis, the switch retaining bracket for a particular compartment may be removed without removing the brackets for other compartments. The brackets are mounted by means of screws at the partition shields.

When the switch retaining bracket is replaced, the switch stator sections must be first accurately positioned so that the movable contacts exactly center on the fixed contacts when the switch is set to positions determined by the detent. The retaining bracket is then mounted in position with the adjusting screws backed off. Finally, the adjusting screws must be screwed in to just touch the stators, then backed off to leave a very slight clearance (approximately .005 in.), then locked by means of the lock nuts. UNDER NO CONDITION SHOULD SCREWS EXERT FORCE AGAINST THE STATORS AS THIS WILL CAUSE BENDING, WITH CONSEQUENT BINDING OF THE SWITCH SHAFT.

**CAUTION: DO NOT ALIGN BY MEANS OF SCREWS.**

- 12.16-2 Switch contacts may be tested by pressing the movable contact down on its fixed contact with a tool of insulating material. Associated circuits should be checked for loose contacts before disturbing the switch assembly.
- 12.16-3 The switch is self-cleaning and should wipe itself clean if rotated back and forth over the questionable contact several times. Should further cleaning become necessary, the rotating member may be pressed down against the fixed member far enough to permit disengaging the "C" washer from its slot in the rotating hub at the back of the fixed member. If the "C" washer is removed, the rotating member may be slid along the shaft away from the fixed member permitting access to the contacts. Care must be taken not to compress the springs farther than necessary or they will require readjustment.
- 12.16-4 Should necessity of replacing a switch section arise, the switch shaft must be removed, the switch section connections unsoldered at the switch plate, the new section inserted, connections soldered, and switch shaft replaced. Receiver alignment should then be checked (see 12.17). To remove switch shaft, remove taper pin fastening the bevel gear to the switch shaft. Remove the bearing bushing at the end of the shaft opposite the drive and slide the shaft out, taking care that none of the switch sections are binding on the shaft. When replacing the shaft, see that the bevel gears are properly meshed to provide alignment between switch position and position indicated by the panel control before pinning.

## 12.17 Receiver Alignment.

- 12.17-1 Receiver alignment may be readily checked by observing operation of the panel trimmers (see paragraph 12.9 and Figure 6). These trimmers should resonate the respective tuned circuits at any point in their range. A rough indication may be obtained by noting the increase in receiver noise level as the trimmers are tuned through resonance. For accurate alignment check, the receiver must be adjusted as for sensitivity measurements (see 11.1). This adjustment may be approximated with sufficient accuracy for most purposes by setting the "Sensitivity" control at "9" and the "Regeneration" control at approximately  $\frac{1}{2}$  division above critical oscillation.

- 12.17-2 Bands 1-2-3. Adjust trimmer C-141 to bring the panel "RF Trimmer" settings for the high-frequency ends of bands 1, 2 and 3 as near zero as possible.
- 12.17-3 Bands 4-5-6. Adjust trimmer C-140 to bring the panel "RF Trimmer" settings for the high-frequency ends of bands 4, 5 and 6 as near zero as possible.
- 12.17-4 Bands 7-8-9. Adjust trimmer C-139 to bring the panel "RF Trimmer" settings for the high-frequency ends of bands 7, 8 and 9 as near zero as possible. Set trimmer C-137 to bring panel "Antenna Trimmer" settings for the high-frequency ends of bands 7, 8 and 9 as near zero as possible.
- 12.17-5 The following table gives nominal frequencies and approximate dial settings which should be used in aligning the receiver.

**TABLE No. 11**  
**ALIGNING FREQUENCIES**

<i>Band</i>	<i>Nominal Frequency (KC)</i>	<i>Dial Setting (Approx.)</i>
1	300- 490	79-892
2	490- 800	89-896
3	800- 1,330	85-898
4	1,330- 2,080	64-847
5	2,080- 3,400	57-885
6	3,400- 5,500	69-880
7	5,500- 8,800	58-910
8	8,800-14,300	73-912
9	14,300-23,000	83-858

- 12.17-6 As noted in paragraph 12.9-5, an abnormal change in either trimmer setting over a given band, or failure to resonate at only one end of a band indicates that the tuning condenser section or the inductance used in the particular circuit and band has been damaged. If both trimmer settings change in the same direction over a band, this may indicate that the detector tuning condenser or inductance is at fault. Such conditions on the higher frequency bands may result if the wiring between the band switch and tuned circuit inductances is disarranged.

UNLESS THESE CONDITIONS SERIOUSLY IMPAIR OPERATION, NO ATTEMPT SHOULD BE MADE TO REPAIR INDUCTANCE OR TUNING CAPACITOR ALIGNMENT OR REPLACE COILS. THESE OPERATIONS SHOULD VERY RARELY BECOME NECESSARY AND SHOULD BE DONE ONLY IN A WELL EQUIPPED LABORATORY.

**12.18 Lubrication.**

- 12.18-1 Mechanical moving parts such as tuning condenser drive mechanism, band switch drive mechanism, and bearings should be periodically inspected and, if necessary, lightly greased with a non-fluid mineral oil or light grease such as Grade A of Navy Department Specification 14G 1. Lubrication of electrical contacting surfaces is not advisable unless tendency for cutting appears; when required, a light grease such as vaseline should be used very sparingly, all surplus grease being removed.

**12.19 Cleaning.**

- 12.19-1 ABRASIVE SUBSTANCES SUCH AS EMERY CLOTH, STEEL WOOL, ETC., SHOULD NEVER BE USED FOR CLEANING IN OR ABOUT ANY PART OF THIS EQUIPMENT.

**PARTS AND  
SPARE PARTS  
LIST**

### XIII PARTS LISTS

NAVY TYPE NUMBER	NAME OF MAJOR UNIT	PART DESIGNATION GROUP
CRV-46156 CRV-20131 CRV-23073	Receiver Unit for Model RAL-6 Equipment Power Unit for Model RAL-6 Equipment Control Unit for optional use with Models RAK-6 and RAL-6	101-199 201-299 301-399

**13.1 TABLE No. 12**  
**PARTS LIST BY SYMBOL DESIGNATIONS**  
Receiver Unit CRV-46156

Symbol	Function	Description	Navy Type No.	Navy Spec. or Dwg.	Manufacturer	Mfg. No.	RCA Mfg. Co. Dwg. No.
				<b>CAPACITORS</b>			
*C-101	Antenna series cap. used with "COMMON" antenna connection	Mica cap., molded, 400 mmf. $\pm 10\%$ , 450 V. DC (working) brown phenolic case	CAW-48559		Aerovox Wireless Corp.	1461	K-30088-6
C-102A	Main tuning on 1st RF stage	Var. air cap., 3-gang, 25.3 $\pm 1$ to 207 $\pm 5$ mmfd. per section			Hammarlund Mfg. Co. Inc.		T-601410-2
B	Main tuning on 2nd RF stage						
C	Main tuning on detector stage						
C-103	"ANTENNA TRIMMER" on 1st RF stage	Variable air trimmer, 5.3 to 27 mmfd. $\pm 5\%$ , 4 plates	CHC-48575		Hammarlund Mfg. Co. Inc.		K-815736-2
*C-104A	Cathode RF filter by-pass on 1st RF tube	Paper, oil filled cap., 2 section, 0.125/0.125 mfd. +10% - 3%, 500 V. max. DC, 250 V. peak AC, 500 V. DC (working)	CRV-48555	RE-13A-488C	RCA Mfg. Co., Inc.		P-721074-6
C-105B	Screen RF filter by-pass on 1st RF tube "R-F TRIMMER" on 2nd RF stage	Var. air trimmer, 2 mmfd. (approx.) to 12 mmfd. $\pm 5\%$ (max)	CHC-48573		Hammarlund Mfg. Co. Inc.		K-815737-1
*C-106	Grid coupling between 1st and 2nd RF stages	Mica, toothpick-type cap., 250 mmf. $\pm 10\%$ , 5010 volts DC (working). Sealed in a square steatite container	CRV-48561		RCA Mfg. Co., Inc.	77055-6	K-77055-6
§C-106	Grid coupling between 1st and 2nd RF stages	Capacitor, molded mica, 500 mmfd. $\pm 10\%$ , 500 V. DC (working)	‡48691-D10		†		P-720473-8
*C-107	Plate supply by-pass on 1st RF tube	Mica cap., molded, 0.01 mfd. $\pm 10\%$ , 500 V. DC (working) brown phenolic case	CAW-48341		Aerovox Wireless Corp.	1455 (modified)	K-30090-3
*C-108A	Cathode RF filter by-pass on 2nd RF tube	Same as C-104	CRV-48555				
B	Screen RF filter by-pass on 2nd RF tube Filter by-pass on screen of 2nd RF tube						
*C-109	Filter by-pass on screen of 2nd RF tube	Mica cap., 0.01 mfd. $\pm 10\%$ , 500 V. DC (working)	CRV-48231	RE-48AA-126C Style IV	RCA Mfg. Co., Inc.	T	P-32170-511
*C-110	Plate supply by-pass on 2nd RF tube	Paper, oil-filled cap., 0.1 mfd. +10% - 3%, 500 V. max. DC, 250 V. peak AC, 500 V. DC (working)	CRV-48552	RE-13A-488C	RCA Mfg. Co., Inc.		P-712074-1
C-111	"FREQ. VERNIER" on det. circuit	Var. air trimmer	CHC-48574		Hammarlund Mfg. Co. Inc.		K-815737-2
*C-112	Grid coupling between 2nd RF and detector stages	Same as C-106	CRV-48561				
§C-112	Grid coupling between 2nd RF and detector stages	Same as C-106§	48691-D10				
*C-113	Heater RF filter by-pass on detector tube	Same as C-109	CRV-48231				
*C-114	Heater RF filter by-pass on detector tube	Same as C-109	CRV-48231				
*C-115	Heater RF filter by-pass on detector tube	Same as C-109	CRV-48231				
*C-116	Heater RF filter by-pass on detector tube	Same as C-109	CRV-48231				
*C-117	Filter by-pass on screen and suppressor of detector tube	Paper, oil-filled cap., 1.0 mfd. +10% - 3%, 400 V. max. DC, 125 V. peak AC, 250 V. DC (working)	CRV-48553	RE-13A-488C	RCA Mfg. Co., Inc.		P-721074-2

\*Spare parts furnished for all items preceded by an asterisk.

§Used on receivers for Contract Number 95022, dated December 29, 1941 beginning with serial number 1261.

\*Used on receivers for Contract Number 95022, dated December 29, 1941, serial numbers 1 to 1260 inclusive.

†Aerovox, Micamold, Cornell-Dubilier or Solar.

‡CAW, CMR, CD, CSL.

Symbol Desig.	Function	Description	Navy Type No.	Navy Spec. or Dwg.	Manufacturer	Mfg. No.	RCA Mfg. Co. Dwg. No.
*C-118	Filter by-pass on screen and suppressor of detector tube	Same as C-117	CRV-48553				
*C-119	Used in parallel with C-117 as a screen-suppressor or filter by-pass on detector tube	Same as C-110	CRV-48552				
*C-120	Det. plate circuit RF filter by-pass	Mica cap., 50 mmf. $\pm 5\%$ , 500 V. DC (working)	CRV-48550	RE-48AA-126C Style IV	RCA Mfg. Co., Inc.	T	P-32170-519
*C-121	Det. plate circuit RF filter by-pass	Same as C-120	CRV-48550				
*C-122	Det. plate filter by-pass	Same as C-117	CRV-48553				
*C-123	Coupling cap. between detector plate circuit and 1st audio grid	Same as C-107	CAW-48341				
*C-124	Plate by-pass on 1st audio tube	Mica cap., molded, 0.001 mfd. $\pm 10\%$ , 500 V. DC (working) brown phenolic case	CAW-48557		Aerovox Wireless Corp.	1455 (modified)	K-30090-10
*C-125	Coupling cap. between 1st audio and output tubes	Same as C-124	CAW-48557				
*C-126	Cathode by-pass on 1st audio tube	Same as C-117	CRV-48553				
*C-127	Screen by-pass on 1st audio tube	Same as C-117	CRV-48553				
*C-128	Screen and plate by-pass on output tube	Same as C-117	CRV-48553				
*C-129	Plate filter by-pass on 1st audio tube	Same as C-117	CRV-48553				
*C-130	Cathode by-pass on output tube	Same as C-117	CRV-48553				
*C-131	Cathode by-pass on output tube	Same as C-117	CRV-48553				
*C-132	Cathode by-pass on output tube	Same as C-117	CRV-48553				
*C-133	Plate by-pass on output tube	Same as C-107	CAW-48341				
*C-134	Cathode by-pass on AVC tube	Same as C-117	CRV-48553				
*C-135A	Input filter by-pass on 90-volt "B" supply	Same as C-104	CRV-48555				
B	Input filter by-pass on 180-volt "B" supply						
*C-136A	Input filter by-pass on 6-v. positive supply	Same as C-104	CRV-48555				
B	Input filter by-pass on 6-v. negative supply						
C-137	HF alignment on bands 7, 8 and 9 of antenna 1st RF stage	Var. air trimmer, 5.5 to 35 mmf. $\pm 10\%$	CHC-48576		Hammarlund Mfg. Co. Inc.		K-815736-3
*C-138	Aux. plate filter by-pass in parallel with C-107 on 1st RF tube on LF bands 1, 2 and 3 only	Same as C-110	CRV-48552				
C-139	Used for alignment of bands 7, 8 and 9 of detector	Same as C-137	CHC-48576				
C-140	Used for alignment of bands 4, 5 and 6 of detector	Var. air trimmer, 10 mmf. max. cap., 4-plate, single-bearing, screw-driver adjustment	48582		Oak Mfg. Co.		K-875420-2
C-141	Used for alignment of bands 1, 2 and 3 detector	Same as C-140	48582				
*C-142	Detuning cap. on Pri. winding of LF det. coil when band 7 is being used	Mica, toothpick-type cap., 500 mmf. $\pm 10\%$ , 500 V. DC (working), solid wire leads impregnated and covered with compound	CRV-48571		RCA Mfg. Co., Inc.	H	M-86016-506
*C-143	Series tuning cap. used with var. attenuator L-114	Paper cap., oil-filled, 0.025 mfd. $+10\% - 3\%$ , 500 V. DC (working)	CRV-48806	RE-13A-488C	RCA Mfg. Co., Inc.		P-721074-4
*C-144	Series tuning cap. used with var. attenuator L-114	Paper cap., oil-filled, 0.075 mfd. $+10\% - 3\%$ , 500 V. DC (working)	CRV-48807	RE-13A-488C	RCA Mfg. Co., Inc.		P-721074-5
*C-145	Output cable filter by-pass	Capacitor, molded mica, 0.01 mfd. $\pm 10\%$ , 300 V. DC (working)	†---48938-10		†		P-720473-15
*C-146	Output cable filter by-pass	Same as C-145	†---48938-10				
*C-147	Output jack filter by-pass	Same as C-145	†---48938-10				
*C-148	Output jack filter by-pass	Same as C-145	†---48938-10				
				COIL SHIELDS			
CS-101	Shield for L-101	Coil shield, copper, threaded, 4" dia., 3" long			RCA Mfg. Co., Inc.	401466-3	M-401466-3
CS-102	Shield for L-102	Coil shield, copper, threaded, 3" dia., 4½" long			RCA Mfg. Co., Inc.	401466-5	M-401466-5
CS-103	Shield for L-103	Coil shield, copper, threaded, 2¼" dia., 4½" long			RCA Mfg. Co., Inc.	815824-1	K-815824-1

\*Spare parts furnished for all items preceded by an asterisk.

†Aerovox, Micamold, Cornell-Dubilier, Solar.

‡CAW, CMR, CD, CSL.

**13.1 TABLE No. 12 (Continued)**  
**PARTS LIST BY SYMBOL DESIGNATIONS**  
Receiver Unit CRV-46156

Symbol Desig. S U R	Function	Description	Navy Type No.	Navy Spec. or Dwg.	Manufacturer	Mfg. No.	RCA Mfg. Co. Dwg. No.
CS-104 CS-105 CS-106 CS-107 CS-108 CS-109	Shield for L-104 Shield for L-105 Shield for L-106 Shield for L-107 Shield for L-108 Shield for L-109	Same as CS-101 Same as CS-102 Same as CS-103 Same as CS-101 Same as CS-102 Same as CS-103					
<b>JACKS</b>							
J-101	Headphone connection	Telephone jack, 4-spring, 2-circuit	CYM-49021	RE-13A-481D	Yaxley Mfg. Co.	B-113667	K-833982-1
<b>INDUCTANCES</b>							
L-101	Ant. coupling coil and 1st RF tuned circuit inductance for bands 1, 2 and 3	Coil, r-f, comprising 4 windings on steatite ceramic tube 1" dia. x $2\frac{5}{8}$ " long with 5 terminals. 1st, 3rd and 4th sections universal wound with litz (10/A.W.G. No. 41 E.) D.S.C. wire using 4 crosses per turn and $\frac{1}{8}$ " wire traverse; 2nd section single-layer close wound with A.W.G. No. 30 E.S.S.C. wire. Spacing $1\frac{3}{16}$ " from terminal end of tube to 1st section, $\frac{1}{32}$ " between 1st and 2nd sections, $\frac{3}{8}$ " between 1st and 3rd sections, and $\frac{1}{16}$ " between 3rd and 4th sections 1st Section: 70 turns 2nd Section: 5 turns 3rd and 4th Sections: 90 turns each			RCA Mfg. Co., Inc.	701642-501	P-701642-501
L-102	Ant. coupling coil and 1st RF tuned circuit inductance for bands 4, 5 and 6	Coil, r-f, comprising 4 single-layer windings on steatite ceramic threaded (32/inch) tube $1\frac{1}{2}$ " dia. x 4" long with 5 terminals. 1st, 2nd and 3rd sections wound in thread with A.W.G. No. 26 E. wire; 4th section wound in groove with A.W.G. No. 30 E. wire 1st Section: 15 turns, started $1\frac{5}{32}$ " from terminal end and wound toward opposite end skipping 4 threads upon completing $4\frac{3}{4}$ turns 2nd Section: 16 turns, started $1\frac{27}{32}$ " from terminal end and wound toward opposite end skipping 4 threads upon completing $11\frac{3}{4}$ turns 3rd Section: 31 turns, started $2\frac{9}{16}$ " from terminal end and wound toward opposite end skipping 4 threads upon completing 28 turns 4th Section: 5 turns in groove 0.063" deep and located approx. $1\frac{25}{32}$ " from terminal end			RCA Mfg. Co., Inc.	701654-501	P-701654-501



Symbol	Function	Description	Navy Type No.	Navy Spec. or Dwg.	Manufacturer	Mfg. No.	RCA Mfg. Co. Dwg. No.
L-103	Ant. coupling coil and 1st RF tuned circuit inductance for bands 7, 8 and 9	Coil, r-f, comprising 2 single-layer windings on steatite ceramic threaded (16/inch) tube 1" dia. x 3¼" long with 6 terminals. 1st section wound in thread with A.W.G. No. 17 E. wire; 2nd section wound in groove with A.W.G. No. 30 E.S.S.C. wire			RCA Mfg. Co., Inc.	701660-501	P-701660-501
	Ant. coupling coil and 1st RF tuned circuit inductance for bands 7, 8 and 9	1st Section: 15 turns, started 13⁄8" from terminal end and wound toward opposite end with taps at 8th and 12th turns 2nd Section: 2-6/7 turns in groove 0.060" deep and located 1 9⁄16" from terminal end					
L-104	Pri. and 2nd RF tuned circuit inductance for bands 1, 2 and 3	Coil, r-f, same as L-101 except 2nd section universal wound and spaced 1⁄8" from 1st section. 2nd section consists of 20 turns A.W.G. No. 30 E.S.S.C. wire with 4 crosses per turn and 1⁄8" wire traverse			RCA Mfg. Co., Inc.	701642-502	P-701642-502
L-105	2nd RF tuned circuit inductance for bands 4, 5 and 6	Coil, r-f, comprising 3 single-layer windings on steatite ceramic threaded (32/inch) tube 1½" dia. x 4" long with 5 terminals. Sections same as in L-102 except as noted below 1st Section: Same as 1st section of L-102 except with 4-thread skip in winding at 3¾ turns and tap brought out at end of next 9 turns 2nd Section: Same as 2nd section of L-102 except with 4-thread skip in winding at 12¼ turns 3rd Section: Same as 3rd section of L-102 except 32 turns and 3-thread skip in winding upon completing 27¼ turns			RCA Mfg. Co., Inc.	701655-501	P-701655-501
L-106	2nd RF tuned circuit inductance for bands 7, 8 and 9	Coil, r-f, single-layer winding on steatite ceramic threaded (16/inch) tube 1" dia. x 3¼" long with 4 terminals. Winding same as 1st section of L-103			RCA Mfg. Co., Inc.	407195-501	M-407195-501
L-107	Pri. detector tuned circuit inductance and "regeneration" windings for bands 1, 2 and 3	Coil, r-f, comprising 7 windings on steatite ceramic tube 1" dia. x 2 5⁄8" long with 8 terminals. 1st, 4th and 7th sections single-layer close wound with A.W.G. No. 30 E.S.S.C. wire; 2nd, 3rd, 5th and 6th sections same as L-104 except as noted below. Spacing 3⁄2" between 1st and 2nd, 4th and 5th, and 6th and 7th sections respectively 1st Section: 4¼ turns 2nd Section: Same as 1st section of L-104 3rd Section: Same as 2nd section of L-104 except 28 turns 4th Section: 3 turns 5th and 6th Sections: Same as 3rd and 4th sections of L-104 respectively 7th Section: 3 turns			RCA Mfg. Co., Inc.	701642-503	P-701642-503

**13.1 TABLE No. 12 (Continued)**  
**PARTS LIST BY SYMBOL DESIGNATIONS**  
Receiver Unit CRV-46156

Symbol Desig.	Function	Description	Navy Type No.	Navy Spec. or Dwg.	Manufacturer	Mfg. No.	RCA Mfg. Co. Dwg. No.
L-108	Pri. detector tuned circuit inductance and "regeneration" windings for bands 4, 5 and 6	Coil, r-f, comprising 5 single-layer windings on steatite ceramic threaded (32/inch) tube $1\frac{1}{2}$ " dia. x 4" long with 7 terminals. 1st, 2nd, 3rd and 4th sections same as L-102 except as noted below; 5th section wound in thread with A.W.G. No. 30 E. wire 1st Section: Same as 1st section of L-102 except with 4-thread skip in winding at 11 turns 2nd Section: Same as 2nd section of L-102 except with 4-thread skip in winding at 4 turns 3rd Section: Same as 3rd section of L-102 4th Section: Same as 4th section of L-102 except groove located approx. $1\frac{1}{8}$ " from terminal end 5th Section: 2 turns, started $2\frac{1}{2}$ " from terminal end and wound toward opposite end $\frac{3}{8}$ turn, then returned to a point $1\frac{1}{8}$ " from terminal end and wound toward opposite end $1\frac{1}{8}$ turns			RCA Mfg. Co., Inc.	701656-501	P-701656-501
L-109	Detector tuned circuit inductance for bands 7, 8 and 9	Coil, r-f, comprising 3 single-layer windings on steatite ceramic threaded (16/inch) tube 1" dia. x $3\frac{1}{4}$ " long with 9 terminals. 1st and 2nd sections wound in thread and 3rd section in groove. 1st and 3rd sections same as L-103 except as noted below. 2nd section wound with A.W.G. No. 30 E.S. S.C. wire 1st Section: Same as 1st section of L-103 except tapped at 3, 7 and 14 turns 2nd Section: 2-1/7 turns, started $1\frac{5}{8}$ " from terminal end and wound toward opposite end 3rd Section: Same as 2nd section of L-103 except 1-1/7 turns and groove 0.045" deep			RCA Mfg. Co., Inc.	701661-501	P-701661-501
L-110	RF choke used as filter in heater lead of detector tube	Coil, r-f, 30 turns A.W.G. No. 20 E. wire, single-layer close wound on fibre tube $\frac{1}{2}$ " dia. x $1\frac{3}{4}$ " long			RCA Mfg. Co., Inc.	815800-501	K-815800-501
L-111	RF choke used as filter in heater lead of detector tube	Same as L-110					

Symbol Desig.	Function	Description	Navy Type No.	Navy Spec. or Dwg.	Manufacturer	Mfg. No.	RCA Mfg. Co. Dwg. No.
L-112	RF choke used as part of plate filter on detector	Coil, r-f choke, 475 turns A.W.G. No. 36 E.S.S.C. wire, universal wound with 4 crosses per turn and $\frac{1}{8}$ " wire traverse on wood bobbin $\frac{1}{2}$ " dia. x $\frac{5}{8}$ " long, entirely enclosed and sealed in phenolic shell. Inductance $0.005 \text{ h} \pm 10\%$ at 175 kc. DC resistance 44 ohms	CRV-47094		RCA Mfg. Co., Inc.	815819-501	K-815819-501
L-113	Low-pass filter between detector plate and 1st audio grid to attenuate audio-frequency response above 1200 cycles	Filter, impregnated and sealed in can with six leads. Consists of two parts: (1) A single reactor of 40 henries, and (2) a network of three reactors in series and six capacitors, four of which form the legs. From input to output side, the reactors are 22.8 h, 13.2 h, and 13.2 h respectively. The four capacitors forming the legs are, from input to output side, 2000 mmfd, 1800 mmfd, 1300 mmfd, and 1500 mmfd. One 650-mmfd capacitor is connected across each of the 13.2-h reactors. Voltage rating of each capacitor is 500 volts DC (working)	CRV-53032		RCA Mfg. Co., Inc.	RT-363	P-72402-502
*L-114	Var. attenuator used optionally across grid circuit of 1st audio stage for audio tuning	Reactor, impregnated and sealed in can. Consists of 2500 turns A.W.G. No. 29 E. wire with taps located as follows from input to output side: 1360, 1460, 1560, 1670, 1780, 1910, 2040, 2180, and 2340 turns. Coil traverse $\frac{1}{4}$ ", DC resistance, 86 ohms	CRV-30343		RCA Mfg. Co., Inc.	RT-528	P-72397-502
*L-115	Output cable filter	RF choke, single layer wound on steatite core, 1000 MA rating. Inductance 5.5 microhenries, 0.85 ohms DC resistance					K-871304-1
*L-116	Output cable filter	Same as L-115					
L-117A	Output jack filter	Dual RF choke, comprising 2 single layer, right-hand, close wound windings of 30 turns each. Wound together in bifilar on laminated phenolic form, $\frac{1}{2}$ " dia. x $\frac{1}{8}$ " long. Coil mounted between $2\frac{1}{16}$ " thick laminated phenolic terminal boards 1" wide x $1\frac{1}{4}$ " long each having 2 brass, open terminals			RCA Mfg. Co., Inc.		K-865413-501
*L-118	Output jack filter Antenna series choke for u-h-f signal pick-up suppression	Same as L-115					
METERS							
*M-101	Connected across output	Output meter, zero center, -10 to +5 db $\pm 5\%$ , 5000 ohms $\pm 5\%$ DC resistance, $2\frac{1}{2}$ " dia. flush type. Reference output impedance 600 ohms; zero power level 6 milliwatts	CAY-22152	17-I-12a	Westinghouse Elec. and Mfg. Co.	MC (rectifier type)	M-420279-5
*M-102	Connected across heater leads	Voltmeter, AC-DC, 0 to 10 V. $\pm 2\%$ (15-100 cycles and 5 to 7 V. DC) $2\frac{1}{2}$ " dia. flush type	CAY-22246	17-I-12a	Westinghouse Elec. and Mfg. Co.	MA	M-420279-6

\*Spare parts furnished for all items preceded by an asterisk.

•Ohmite Mfg. Co., Hardwick & Hinkle.

**13.1 TABLE No. 12 (Continued)**  
**PARTS LIST BY SYMBOL DESIGNATIONS**  
Receiver Unit CRV-46156

Symbol Desig.	Function	Description	Navy Type No.	Navy Spec. or Dwg.	Manufacturer	Mfg. No.	RCA Mfg. Co. Dwg. No.
				<b>RESISTORS</b>			
*R-101	Parasitic suppressor in grid circuit of 1st RF tube	100 ohms $\pm 10\%$ , 1/2-watt, wire wound, pigtail			†		K-857034-11
*R-102	Cathode bias and filter resistor on 1st RF tube	510 ohms $\pm 5\%$ , 1/2 watt, composition, pigtail	† --- 63355	RE-13A-372G	†		K-850981-152
*R-103	Screen filter on 1st RF tube	10,000 ohms $\pm 10\%$ , 1/2 watt, composition, pigtail	† --- 63360	RE-13A-372G	†		K-850981-74
*R-104	Plate filter on 1st RF tube	Same as R-103	† --- 63360				
*R-105	Part of RF screen voltage divider	7500 ohms $\pm 5\%$ , 1 watt, composition, pigtail	† --- 63291	RE-13A-372G	†		K-844314-180
*R-106	Part of RF screen voltage divider	11,000 ohms $\pm 5\%$ , 1 watt, composition, pigtail	† --- 63291	RE-13A-372G	†		K-844314-184
*R-107	Grid resistor on 2nd RF tube	1 megohm $\pm 10\%$ , 1/2 watt, composition, pigtail	† --- 63360	RE-13A-372G	†		K-850981-98
*R-108	Cathode bias resistor on 2nd RF tube	Same as R-102	† --- 63355				
*R-109	Screen filter on 2nd RF tube	Same as R-103	† --- 63360				
*R-110	Plate filter on 2nd RF tube	Same as R-103	† --- 63360				
*R-111	Grid leak on detector tube	2.2 megohms $\pm 10\%$ , 1/2 watt, composition, pigtail	† --- 63360	RE-13A-372G	†		K-850981-102
*R-112	Screen suppressor filter on detector tube	Same as R-103	† --- 63360				
*R-113	Used as part of RF filter in plate circuit of detector tube	Same as R-103	† --- 63360				
*R-114	Plate load on detector tube	100,000 ohms $\pm 10\%$ , 1/2 watt, composition, pigtail	† --- 63360	RE-13A-372G	†		K-850981-86
*R-115	Part of detector screen voltage divider	24,000 ohms $\pm 5\%$ , 1/2 watt, composition, pigtail	† --- 63355	RE-13A-372G	†		K-850981-192
*R-116	Part of detector screen voltage divider	51,000 ohms $\pm 5\%$ , 1/2 watt, composition, pigtail	† --- 63355	RE-13A-372G	†		K-850981-200
*R-117	Plate filter on detector tube	Same as R-103	† --- 63360				
*R-118	Plate filter on 2nd RF and detector tubes	10,000 ohms $\pm 10\%$ , 1 watt, composition, pigtail	† --- 63288	RE-13A-372G	†		K-844314-74
*R-119	Grid resistor on 1st audio tube	Same as R-114	† --- 63360				
*R-120	Plate load on 1st audio tube	Same as R-114	† --- 63360				
*R-121	Grid resistor on output tube	Same as R-107	† --- 63360				
*R-122	Cathode bias resistor on 1st audio tube	1000 ohms $\pm 10\%$ , 1/2 watt, composition, pigtail	† --- 63360	RE-13A-372G	†		K-850981-62
*R-123	Screen filter on 1st audio tube	510,000 ohms $\pm 5\%$ , 1/2 watt, composition, pigtail	† --- 63355	RE-13A-372G	†		K-850981-224
*R-124	Plate filter on 1st audio tube	20,000 ohms $\pm 5\%$ , 1/2 watt, composition, pigtail	† --- 63355	RE-13A-372G	†		K-850981-190
*R-125	Screen and plate filter on output tube	4700 ohms $\pm 10\%$ , 1 watt, composition, pigtail	† --- 63288	RE-13A-372G	†		K-844314-70
*R-126	Cathode bias resistor on output tube	620 ohms $\pm 5\%$ , 1/2 watt, composition, pigtail	† --- 63355	RE-13A-372G	†		K-850981-154
*R-127	Part of output meter multiplier	12,000 ohms $\pm 5\%$ , 1/2 watt, composition, pigtail	† --- 63355	RE-13A-372G	†		K-850981-185
*R-128	Part of output meter multiplier	11,000 ohms $\pm 5\%$ , 1/2 watt, composition, pigtail	† --- 63355	RE-13A-372G	†		K-850981-184
*R-129	Part of output meter multiplier	Same as R-128	† --- 63355				
*R-130	Part of output meter multiplier	3900 ohms $\pm 5\%$ , 1/2 watt, composition, pigtail	† --- 63355	RE-13A-372G	†		K-850981-173

\*Spare parts furnished for all items preceded by an asterisk.

†International, Erie or Allen Bradley.

‡CIR, CER or CBZ.

Symbol	Function	Description	Navy Type No.	Navy Spec. or Dwg.	Manufacturer	Mfg. No.	RCA Mfg. Co. Dwg. No.
*R-131	Impedance limiting resistor across LF det. Sec. winding on bands 1, 2 and 3	Same as R-114	‡ --- 63360				
*R-132A	Grid bias control on 2nd RF tube ("SENSITIVITY")	Potentiometer (dual-unit)—each section 10,000 ohms $\pm 5\%$ , 4 watts—wire wound, linear Potentiometer, 25,000 ohms $\pm 15\%$ , $1\frac{1}{2}$ watts, wire wound, no taper Potentiometer, 20,000 ohms $\pm 10\%$ , $1\frac{1}{2}$ watts, wire wound with 1st quarter—turn clockwise 1000 ohms	CTC-63428	RE-13A-492B	Chicago Telephone Supply Co.	CTS Spec. 583	P-72325-2
*R-133B	Grid bias control on 1st RF tube		CWC-63247	RE-13A-492B	Wirt Company	2650	K-806741-2
*R-134	Screen voltage control on detector tube ("REGENERATION")		CWC-63429	RE-13A-492B	Wirt Company	2651	K-806741-7
			SWITCHES				
*S-101	Connects "AUDIO TUNING" var. attenuator (L-114) across grid circuit of 1st audio tube	Toggle switch, SPST, 1 amp. at 250 V, 3 amp. at 125 V	CHH-24000	RE-24AA-118A	Arrow-Hart & Hegeman Elec. Co.	20994-ET	M-420278-1
*S-102	Connects either high or low freq. "AUDIO TUNING" var. attenuator across grid-circuit of 1st audio tube	Toggle switch, DPDT, 1 amp. at 250 V, 3 amp. at 125 V	CHH-24003	RE-24AA-118A	Arrow-Hart & Hegeman Elec. Co.	20905-EP	M-420278-4
S-103	Used to change taps on var. attenuator	Rotary switch, single wafer, 11-point, stop adjusted for 10 positions	CYM-24029		Yaxley Mfg. Company	1211 (modified)	K-850187-1
*S-104	Connects AVC trans. (T-102) across plate circuit of output tube	Same as S-101	CHH-24000				
S-105	Used to change resistance in series with output "db" meter	Same as S-103 except stop adjusted for 5 positions	CYM-24029				
*S-106	Breaks +A and +B supply on battery-operated equipment	Toggle switch, DPST, 1 amp. at 250 V, 3 amp. at 125 V	CHH-24001	RE-24AA-118A	Arrow-Hart & Hegeman Elec. Co.	20902-CZ	M-420278-3
S-107	1st RF circuit band sw. section	Switch section, 18 silver contacts on Isolantite plates			RCA Mfg. Co., Inc.	601408-501	T-601408-501
S-108	1st RF circuit band sw. section	Same as S-107 except for contact wiring			RCA Mfg. Co., Inc.	601408-502	T-601408-502
S-109	2nd RF circuit band sw. section	Same as S-107 except for contact wiring			RCA Mfg. Co., Inc.	601408-503	T-601408-503
S-110	2nd RF circuit band sw. section	Same as S-107 except for contact wiring			RCA Mfg. Co., Inc.	601408-504	T-601408-504
S-111	Detector circuit band sw. section	Same as S-107 except for contact wiring			RCA Mfg. Co., Inc.	601408-505	T-601408-505
S-112	Detector circuit band sw. section	Same as S-107 except for contact wiring			RCA Mfg. Co., Inc.	601408-506	T-601408-506
S-113	Detector circuit band sw. section	Same as S-107 except for contact wiring			RCA Mfg. Co., Inc.	601408-507	T-601408-507
S-114	Connects detector cathode to ground to stop oscillation ("OSC. TEST")	Push-button, 3-spring contact, steatite base			RCA Mfg. Co., Inc.	815769-501	K-815769-501
*S-115	Connects low-pass audio filter (L-113) in series with detector output circuit	Same as S-102	CHH-24003				
			TRANSFORMERS				
*T-101	Couples plate circuit of output tube to telephone jack; secondary mid-tapped to ground; 600 ohms output impedance	Output transformer; Ratio 3.94 to 1. 427 ohms Pri., 41.7 ohms Sec. DC resistance. Impregnated and sealed in a can	CRV-30242A		RCA Mfg. Co., Inc.	RT-354	M-80158-501
*T-102	Used optionally across plate circuit of output tube to feed grid of AVC tube	AVC transformer: Ratio 1 to 12.5. 57 ohms Pri., 3540 ohms Sec. DC resistance. Impregnated and sealed in a can	CRV-30244		RCA Mfg. Co., Inc.	RT-355	M-80159-501
			TUBE SHIELDS				
TS-101A	Shield for V-101	Tube shield body, aluminum, chimney type, $1\frac{3}{4}$ " dia., $3\frac{3}{4}$ " long Tube shield cap, aluminum, $1\frac{5}{8}$ " dia., $2\frac{1}{16}$ " long			Aluminum Goods Mfg. Co.	Special	K-850358-1
TS-101B						Aluminum Goods Mfg. Co.	S-618
TS-102	Shield for V-102	Same as TS-101					
TS-103	Shield for V-103	Same as TS-101					
TS-104	Shield for V-104	Same as TS-101					

\*Spare parts furnished for all items preceded by an asterisk.

**13.1 TABLE No. 12 (Continued)**  
**PARTS LIST BY SYMBOL DESIGNATIONS**  
Receiver Unit CRV-46156

Symbol Desig.	Function	Description	Navy Type No.	Navy Spec. or Dwg.	Manufacturer	Mfg. No.	RCA Mfg. Co. Dwg. No.
VACUUM TUBES							
*V-101	1st RF ampl.	Triple-grid, supercontrol amplifier tube	-6D6	RE-13A-600A	RCA (Radiotron)	6D6	
*V-102	2nd RF ampl.	Same as V-101	-6D6				
*V-103	Detector	Same as V-101	-6D6				
*V-104	1st audio ampl.	Same as V-101	-6D6				
*V-105	2nd audio ampl.	P. A. pentode tube	-41	RE-13A-600A	RCA (Radiotron)	41	
*V-106	AVC	Same as V-105	-41				
SOCKETS							
*X-101	Receptacle for 1st RF tube	6-prong, wafer-type, ceramic base, 1 $\frac{3}{32}$ " hole centers	CHC-49318	RE-38AA-136A	Hammarlund Mfg. Co., Inc.	S-6 (modified)	K-856996-3
*X-102	Receptacle for 2nd RF tube	Same as X-101	CHC-49318				
*X-103	Receptacle for detector tube	Same as X-101	CHC-49318				
*X-104	Receptacle for 1st audio tube	6-prong, wafer-type, phenolic base	CRV-49308	RE-38AA-140A	RCA Mfg. Co., Inc.	401806-503	M-401806-503
*X-105	Receptacle for 2nd audio tube	Same as X-104	CRV-49308				
*X-106	Receptacle for AVC tube	Same as X-104	CRV-49308				

**Power Unit CRV-20131**

CAPACITORS							
*C-201	RF by-pass on AC input power leads	Same as C-107	CAW-48341				
*C-202	RF by-pass on AC input power leads	Same as C-107	CAW-48341				
*C-203	RF by-pass on AC input power leads	Same as C-107	CAW-48341				
*C-204	Main voltage filter	Capacitor pack paper containing 3/3/3 mfd. $\pm 10\%$ , oil filled, 400 V. max. DC, 200 V. peak AC, 400 V. DC (working)	CRV-48540A	RE-48AA-137A	RCA Mfg. Co., Inc.	72014-507	P-72014-507
FUSES							
*F-201	Used in AC input line	Fuse, glass cartridge type, 3 amp., 250 volts		17-F-2f	Littelfuse Inc.	1043	K-811485-12
*F-202	Used in AC input line	Same as F-201					
INDUCTANCES							
L-201	Used in series with AC input	RF choke, 69 turns A.W.G. No. 18 enameled copper wire wound on 1" dia. phenolic tube			RCA Mfg. Co., Inc.	407170-501	M-407170-501
L-202	Used in series with AC input	Same as L-201					
L-203	Line filter on AC input	RF filter, 2 iron core reactors and 2 paper capacitors, impregnated and sealed in a can. Reactors .073 and .084 ohms resistance, approx., 2 to 12 milli-henries inductance. Capacitors 1.0 mfd. $\pm 10\%$ , 300 V. DC (working) each	CRV-30248		RCA Mfg. Co., Inc.	RT-347	P-705254-503
L-204	Used as 1st section of main filter on DC output; end section in series with middle filter capacitor acts as a tuned low impedance to ripple frequency	Filter reactor, tapped, iron-core, impregnated and sealed, 210 ohms $\pm 7.5\%$ DC resistance, 5200 ohms at 3 V. 60 cycles, .08 amp. DC, 3 leads	CRV-30247		RCA Mfg. Co., Inc.	RT-350	M-406261-504
L-205	Used as 2nd section of main filter on DC output	Same as L-204 except 2 leads	CRV-30246		RCA Mfg. Co., Inc.	RT-349	M-406261-503

\*Spare parts furnished for all items preceded by an asterisk.

Symbol Desig. S U B	Function	Description	Navy Type No.	Navy Spec. or Dwg.	Manufacturer	Mfg. No.	RCA Mfg. Co. Dwg. No.
RESISTORS							
*R-201	Drop resistor in series with current regulator lamp across AC input	80 ohms $\pm 10\%$ , 200 watts, vitreous enamel, ferrule type, $9\frac{5}{8}$ " long	CAO-63184	RE-13A-372G	Ward-Leonard Elec. Co.	8 $\frac{7}{8}$ " D80 Vitrohm with type 307 ferrule	K-806810-2
*R-202	Bleeder across HV output	20,000 ohms $\pm 5\%$ , 2 watts, composition, pigtail	‡ --- 63426	RE-13A-372G	†		K-78724-190
*R-203	Voltage divider in series with voltage regulator tube across HV output to supply 90 volts DC	6200 ohms $\pm 5\%$ , 2 watts, composition, pigtail	‡ --- 63426	RE-13A-372G	†		K-78724-178
*R-204	Used in parallel with R-203	Same as R-203	‡ --- 63426				
SWITCHES							
*S-201	Used to break both sides of AC input	Same as S-106	CHH-24001				
*S-202	Used to disconnect current regulated AC supply from power transformer Pri. tap and to connect AC supply directly across full Pri. windings. This switch to be thrown only with current-regulator tube (V-201) removed	Same as S-102	CHH-24003				
TRANSFORMERS							
T-201	Main high and low voltage AC supply	Power transformer—impregnated and sealed in can—15 leads. Pri. No. 1—62, 65, 68 V; DC res. 2 ohms. Pri. No. 2—110, 115, 120 V; DC res. 5.03 ohms. Plate winding—500 V (mid-tapped); DC res. 250 ohms. Rect. fil. 5.57 V. Ampl. fil. 7.16 V (mid-tapped). All voltages no load at 60 cycles. Pri. No. 1 for use with current regulator tube only	CRV-30444		RCA Mfg. Co., Inc.	XT-2986	K-900536-501
VACUUM TUBES							
*V-201	Current regulator	Current-regulator tube	-876	RE-13A-600A	RCA (Radiotron)	876	
*V-202	Rectifier	Full-wave rectifier tube	-523	RE-13A-600A	RCA (Radiotron)	523	
*V-203	Voltage regulator	Voltage-regulator tube	-874	RE-13A-600A	RCA (Radiotron)	874	
SOCKETS							
X-201	Receptacle for current-regulator tube	Mogul size, encased in porcelain			Bryant Elec. Co.	4062	K-850876-1
*X-202	Receptacle for rectifier tube	4-prong, wafer-type, phenolic base with shock mounting end supports	CRV-49311A		RCA Mfg. Co., Inc.	401485-502	M-401485-502
*X-203	Receptacle for voltage-regulator tube	Same as X-202	CRV-49311A				

\*Spare parts furnished for all items preceded by an asterisk.



**13.1 TABLE No. 12 (Continued)  
PARTS LIST BY SYMBOL DESIGNATIONS**

**Control Unit CRV-23073**

Symbol Desig.	S U B	Function	Description	Navy Type No.	Navy Spec. or Dwg.	Manufacturer	Mfg. No.	RCA Mfg. Co. Dwg. No.
*F-301 *F-302		Used in input line Used in input line	Fuse, glass cartridge type, 5 amp., 250 volts Same as F-301		FUSES 17-F-2f	Littlefuse, Inc.	1358	K-55544-36
J-301 J-302		Output jack Output jack	Same as J-101 Same as J-101	CMS-49021 CMS-49021	JACKS			
*S-301 *S-302 S-303		Power switch Power switch Used to connect output of either receiver unit or of both to telephone jacks	Same as S-106 Same as S-106 Mixer switch, low capacity, 4-pole, 3-position	CHH-24001 CHH-24001	SWITCHES	Stromberg-Carlson Telephone Mfg. Co.	172A (modified)	K-855530-2

**13.2 TABLE No. 13**  
**PARTS LIST BY NAVY TYPE NUMBERS**  
(The quantities listed do not include the spare parts)  
CRV-46156 Receiver Unit for Model RAL-6  
CRV-20131 Power Unit for Model RAL-6  
CRV-23073 Control Unit for Optional Use with Models RAL-6 and RAK-6

Quantity	Navy Type No.	Symbol Designations	Description
<b>MISCELLANEOUS (CLASS 10)</b>			
3		CS-101, CS-106, CS-109	Coil shield, copper, 2¼" dia., 4½" long
3		CS-102, CS-105, CS-108	Coil shield, copper, 3" dia., 4½" long
3		CS-103, CS-104, CS-107	Coil shield, copper, 4" dia., 3" long
5		TS-101, TS-102, TS-103, TS-104, TS-105	Tube shield and cap, aluminum
<b>INDICATING INSTRUMENTS (CLASS 22)</b>			
1	- 22152	M-101	
1	- 22246	M-102	
<b>SWITCHES (CLASS 24)</b>			
2	- 24000	S-101, S-104	Switch segment, 18 contacts
4	- 24001	S-106, S-201, S-301, S-302	Switch segment, 18 contacts
3	- 24003	S-102, S-115, S-202	Switch segment, 18 contacts
2	- 24029	S-103, S-105	Switch segment, 18 contacts
1		S-107	Switch segment, 18 contacts
1		S-108	Switch segment, 18 contacts
1		S-109	Switch segment, 18 contacts
1		S-110	Switch segment, 18 contacts
1		S-111	Switch segment, 18 contacts
1		S-112	Switch segment, 18 contacts
1		S-113	Switch segment, 18 contacts
1		S-114	Push-button, 3 contacts
1		S-303	Low-capacity, 4-pole, 3-pos. switch
<b>FUSES, PROTECTIVE DEVICES, ETC. (CLASS 28)</b>			
2		F-201, F-202	Fuse, 3 amps., 250 volts
2		F-301, F-302	Fuse, 5 amps., 250 volts
<b>A-F TRANSFORMERS AND REACTORS (CLASS 30)</b>			
1	- 30242A	T-101	
1	- 30244	T-102	
1	- 30246	L-205	
1	- 30247	L-204	
1	- 30248	L-203	
1	- 30343	L-114	
1	- 30444	T-201	
<b>VACUUM TUBES AND V. T. SOCKETS (CLASS 38)</b>			
2	- 41	V-105, V-106	
1	- 874	V-203	
1	- 876	V-201	
3	- 49308	X-104, X-105, X-106	
2	- 49311A	X-202, X-203	
3	- 49318	X-101, X-102, X-103	
1	- 523	V-202	
4	- 6D6	V-101, V-102, V-103, V-104	
1		X-201	Mogul size ceramic socket
<b>R-F INDUCTANCES (CLASS 47)</b>			
1		L-101	Antenna coil
1		L-102	Antenna coil
1		L-103	Antenna coil
1		L-104	RF coil
1		L-105	RF coil
1		L-106	RF coil
1		L-107	Detector coil
1		L-108	Detector coil
1		L-109	Detector coil
1		L-110	RF choke
1		L-111	RF choke
1		L-112	
3	- 47094	L-115, 116, 118	RF choke
1		L-117A & B	RF choke
2		L-201, L-202	RF choke
<b>CAPACITORS (CLASS 48)</b>			
5	- 48231	C-109, C-113, C-114, C-115, C-116	
6	- 48341	C-107, C-123, C-133, C-201, C-202, C-203	
1	- 48540A	C-204	

**13.2 TABLE No. 13 (Continued)**  
**PARTS LIST BY NAVY TYPE NUMBERS**

Quantity	Navy Type No.	Symbol Designations	Description
CAPACITORS (CLASS 48)—Continued			
2	- 48550	C-120, C-121	
3	- 48552	C-110, C-119, C-138	
11	- 48553	C-117, C-118, C-122, C-126, C-127, C-128, C-129, C-130, C-131, C-132, C-134	
4	- 48555	C-104, C-108, C-135, C-136	
2	- 48557	C-124, C-125	
1	- 48559	C-101	
+2	- 48561	C-106, C-112	
1	- 48571	C-142	
1	- 48573	C-105	
1	- 48574	C-111	
1	- 48575	C-103	
2	- 48576	C-137, C-139	
2	- 48582	C-140, C-141	
§2	- 48691	C-106, C-112	
1	- 48806	C-143	
1	- 48807	C-144	
4	- 48938-10	C-145, C-146, C-147, C-148	
1		C-102	Variable air capacitor, 3-gang, 25.3 ±1 to 207 mmf. ±5 %
JACKS, PLUGS, PHONES, ETC. (CLASS 49)			
3	- 49021	J-101, J-301, J-302	
FILTERS (CLASS 53)			
1	- 53032	L-113	
RESISTORS, POTENTIOMETERS, ETC. (CLASS 63)			
1	- 63184	R-201	
1	- 63247	R-133	
1	- 63288	R-125	4,700 ohms
1	- 63288	R-118	10,000 ohms
1	- 63291	R-105	7,500 ohms
1	- 63291	R-106	11,000 ohms
2	- 63355	R-102, R-108	510 ohms
1	- 63355	R-126	620 ohms
1	- 63355	R-130	3,900 ohms
2	- 63355	R-128, R-129	11,000 ohms
1	- 63355	R-127	12,000 ohms
1	- 63355	R-124	20,000 ohms
1	- 63355	R-115	24,000 ohms
1	- 63355	R-116	51,000 ohms
1	- 63355	R-123	510,000 ohms
1	- 63360	R-122	1,000 ohms
7	- 63360	R-103, R-104, R-109, R-110, R-112, R-113, R-117	10,000 ohms
4	- 63360	R-114, R-119, R-120, R-131	100,000 ohms
2	- 63360	R-107, R-121	1 megohm
1	- 63360	R-111	2.2 megohms
2	- 63426	R-203, R-204	6,200 ohms
1	- 63426	R-202	20,000 ohms
1	- 63428	R-132	
1	- 63429	R-134	
1		R-101	100 ohms

\*Used on receivers serial numbers 1 to 1260 inclusive.  
§Used on receivers serial numbers 1261 and up.

13.3 TABLE No. 14

SPARE PARTS LIST BY NAVY TYPE DESIGNATIONS

CRV-46156 Receiver Unit for Model RAL-6

CRV-20131 Power Unit for Model RAL-6

CRV-23073 Control Unit for Optional Use with RAL-6 and RAK-6

Contract NOs-95022—Dated: 29 Dec., 1941

Quan.	Navy Type No.	Symbol Designations	Description	RCA Mfg. Co. Dwg. No.
			CRV-46156 RECEIVER	
1	CRV-10012		Spanner wrench	K-815970-501
1	CAY-22152	M-101	Output meter, -10 to +5 db.	M-420279-5
1	CAY-22246	M-102	AC/DC voltmeter, 0 to 10 volts	M-420279-6
1	CHH-24000	S-101, S-104	Toggle switch (SPST)	M-420278-1
1	CHH-24001	S-106, S-201, S-301, S-302	Toggle switch (DPST)	M-420278-3
1	CHH-24003	S-102, S-115, S-202	Toggle switch (DPDT)	M-420278-4
1	CRV-30242A	T-101	Output transformer; DC res. Pri. 427, Sec. 41.7 ohms	M-80158-501
1	CRV-30244	T-102	AVC transformer; DC res. Pri. 57, Sec. 3540 ohms	M-80159-501
1	CRV-30343	L-114	Var. AF attenuator, DC res. 86 ohms	P-72397-502
2		L-115, 116, 118	RF choke	K-871304-1
2	*41	V-105, V-106	P. A. pentode tube	
2	CRV-49308	X-104, X-105, X-106	Tube socket, 6-prong, wafer-type, phenolic base	M-401806-503
2	CHC-49318	X-101, X-102, X-103	Tube socket, 6-prong, wafer-type, ceramic base	K-856996-3
4	*6D6	V-101, V-102, V-103, V-104	Triple-grid super-control amplifier tube	
3	CRV-48231	C-109, C-113, C-114, C-115, C-116	Capacitor, mica, Faradon Model "T", 0.01 mfd. ±10%, 500 V. DC (working)	P-32170-511
2	CAW-48341	C-107, C-123, C-133, C-201, C-202, C-203	Capacitor, moulded mica, 0.01 mfd. ±10%, 500 V. DC (working)	K-30090-3
1	CRV-48550	C-120, C-121	Capacitor, mica, Faradon Model "T", 50 mmf. ±5%, 500 V. DC (working)	P-32170-519
2	CRV-48552	C-110, C-119, C-138	Capacitor, paper, oil-filled, 0.1 mfd. +10% -3%, 500 V. DC (working)	P-721074-1
6	CRV-48553	C-117, C-118, C-122, C-126, C-127, C-128, C-129, C-130, C-131, C-132, C-134	Capacitor, paper, oil-filled, 1 mfd. +10% -3%, 250 V. DC (working)	P-721074-2
2	CRV-48555	C-104, C-108, C-135, C-136	Capacitor, paper, oil-filled, 0.125/0.125 mfd. +10% -3%, 500 V. DC (working)	P-721074-6
1	CAW-48557	C-124, C-125	Capacitor, moulded mica, 0.001 mfd. ±10%, 500 V. DC (working)	K-30090-10
1	CAW-48559	C-101	Capacitor, moulded mica, 400 mmf. ±10%, 450 V. DC (working)	K-30088-6
*1	CRV-48561	C-106, C-112	Capacitor, mica, toothpick, 250 mmf. ±10%, 500 V. DC (working)	K-77055-6
1	CRV-48571	C-142	Capacitor, mica, toothpick, 500 mmf. ±10%, 500 V. DC (working)	M-86016-506
§1	†48691-D10	C-106, 112	Capacitor, molded mica, 500 mmf. ±10%, 500 V. DC (working)	P-720473-8
1	CRV-48806	C-143	Capacitor, paper, oil-filled, 0.025 mfd. +10% -3%, 600 V. DC (working)	P-721074-4
1	CRV-48807	C-144	Capacitor, paper, oil-filled, 0.075 mfd. +10% -3%, 600 V. DC (working)	P-721074-5
2	†48938-10	C-145, 146, 147, 148	Capacitor, molded mica, 0.01 mfd. ±10%, 300 V. DC (working)	P-720473-15
1	CWC-63247	R-133	25,000-ohm ±15%, 1½-watt, potentiometer	K-806741-2
1	†63288	R-125	4,700-ohm ±10%, 1-watt, composition resistor	K-844314-70
1	†63288	R-118	10,000-ohm ±10%, 1-watt, composition resistor	K-844314-74
1	†63291	R-105	7,500-ohm ±5%, 1-watt, composition resistor	K-844314-180
1	†63291	R-106	11,000-ohm ±5%, 1-watt, composition resistor	K-844314-184
1	†63355	R-102, R-108	510-ohm ±5%, ½-watt, composition resistor	K-850981-152
1	†63355	R-126	620-ohm ±5%, ½-watt, composition resistor	K-850981-154
1	†63355	R-130	3,900-ohm ±5%, ½-watt, composition resistor	K-850981-173
1	†63355	R-128, R-129	11,000-ohm ±5%, ½-watt, composition resistor	K-850981-184
1	†63355	R-127	12,000-ohm ±5%, ½-watt, composition resistor	K-850981-185
1	†63355	R-124	20,000-ohm ±5%, ½-watt, composition resistor	K-850981-190
1	†63355	R-115	24,000-ohm ±5%, ½-watt, composition resistor	K-850981-192
1	†63355	R-116	51,000-ohm ±5%, ½-watt, composition resistor	K-850981-200
1	†63355	R-123	510,000-ohm ±5%, ½-watt, composition resistor	K-850981-224
1	†63360	R-122	1,000-ohm ±10%, ½-watt, composition resistor	K-850981-62
4	†63360	R-103, R-104, R-109, R-110, R-112, R-113, R-117	10,000-ohm ±10%, ½-watt, composition resistor	K-850981-74
2	†63360	R-114, R-119, R-120, R-131	100,000-ohm ±10%, ½-watt, composition resistor	K-850981-86
1	†63360	R-107, R-121	1-megohm ±10%, ½-watt, composition resistor	K-850981-98
1	†63360	R-111	2.2-megohm ±10%, ½-watt, composition resistor	K-850981-102
1	CTC-63428	R-132	Dual-unit potentiometer each section 10,000-ohms ±5%, 4 watts	P-72325-2
1	CWC-63429	R-134	20,000-ohm ±10%, 1½-watt potentiometer (1000 ohms at 1st quarter-turn clockwise)	K-806741-7
1		R-101	100-ohm ±10%, ½-watt, wire wound resistor	K-857034-11
1			Spare parts box	T-620059-504

\*Spare tubes are packed in separate carton.

†CIR, CER, or CBZ.

‡CMR, CD, CSC or CAW.

§Used on receivers for Contract No. 95022, dated December 29, 1941 beginning with serial number 1261.

\*Used on receivers for Contract No. 95022, dated December 29, 1941, serial numbers 1 to 1260 inclusive.

13.3 TABLE No. 14 (Continued)

SPARE PARTS LIST BY NAVY TYPE DESIGNATIONS

CRV-46156 Receiver Unit for Model RAL-6

CRV-20131 Power Unit for Model RAL-6

CRV-23073 Control Unit for Optional Use with RAL-6 and RA5

Contract NOs-95022—Dated: 29 Dec., 1941

Quan.	Navy Type No.	Symbol Designations	Description	RCA Mfg. Co. Dwg. No.
CRV-20131 POWER UNIT				
1	CHH-24001	S-106, S-201, S-301, S-302	Toggle switch (DPST)	M-420278-3
1	CHH-24003	S-102, S-115, S-202	Toggle switch (DPDT)	M-420278-4
1		F-201, F-202	Fuse, 3 amps., 250 volts	K-811485-12
1		F-301, F-302	Fuse, 5 amps., 250 volts	K-55544-36
1	*-874	V-203	Voltage regulator tube	
1	*-876	V-201	Current regulator tube	
1	CRV-49311A	X-202, X-203	Tube socket, 4-prong, wafer-type, phenolic base	M-401485-502
1	<del>6Z3-52</del>	V-202	Full-wave rectifier tube	
2	CAW-48341	C-107, C-123, C-133, C-201, C-202, C-203	Capacitor, moulded mica, 0.01 mfd. $\pm 10\%$ , 500 V. DC (working)	K-30090-3
1	CRV-48540A	C-204	Capacitor pack, paper 3/3/3 mfd. $\pm 10\%$ , 400 V. DC (working)	P-72014-507
1	CAO-63184	R-201	80-ohm $\pm 10\%$ , 200-watt, vitreous enamel resistor	K-806810-2
1	†63426	R-203, R-204	6,200-ohm $\pm 5\%$ , 2-watt composition pigtail resistor	K-78724-178
1	†63426	R-202	20,000-ohm $\pm 5\%$ , 2-watt composition pigtail resistor	K-78724-190

\* Spare Tubes are packed in separate carton.

Figure 15—Outline and Installation  
(P-720164)

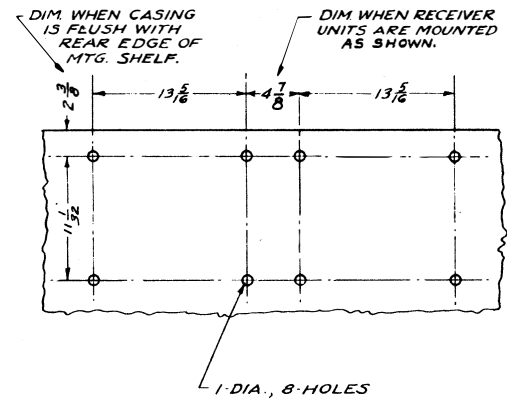
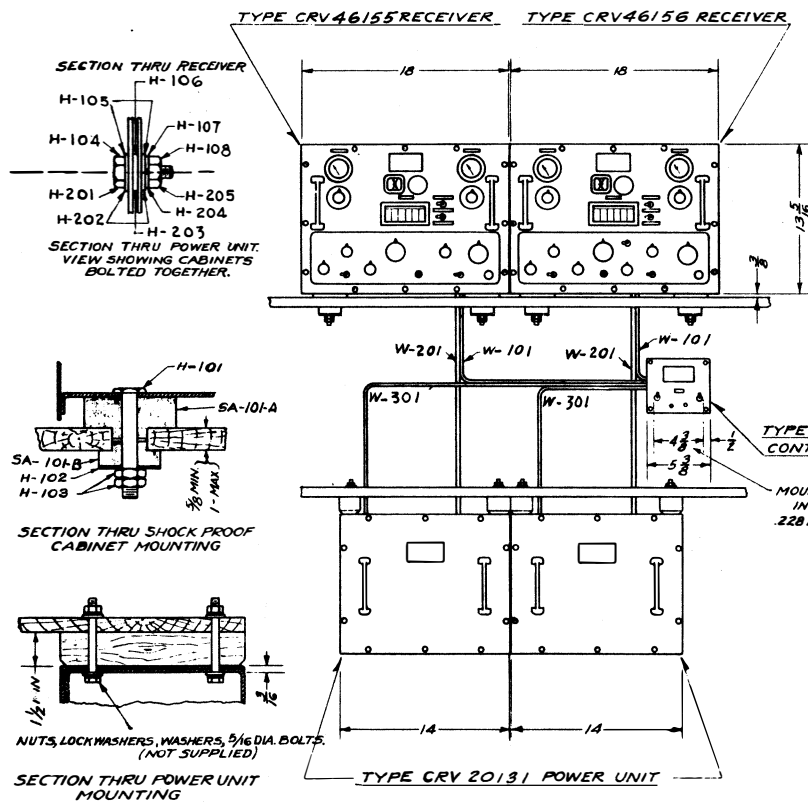

DRILLING PLAN FOR RECEIVER UNITS

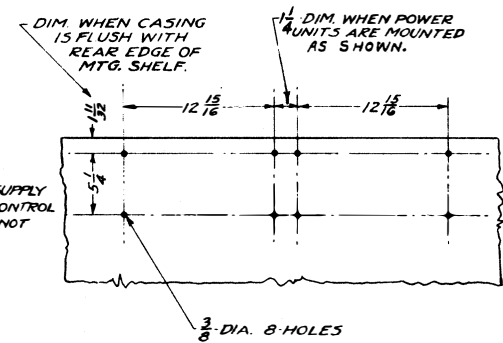

DRILLING PLAN FOR POWER UNITS

WEIGHTS  
CRV-46155 RECEIVER—74 LBS.  
CRV-46156 RECEIVER—69 LBS.  
CRV-20131 POWER UNIT—42 LBS.  
CRV-23073 CONTROL UNIT—2 LBS.

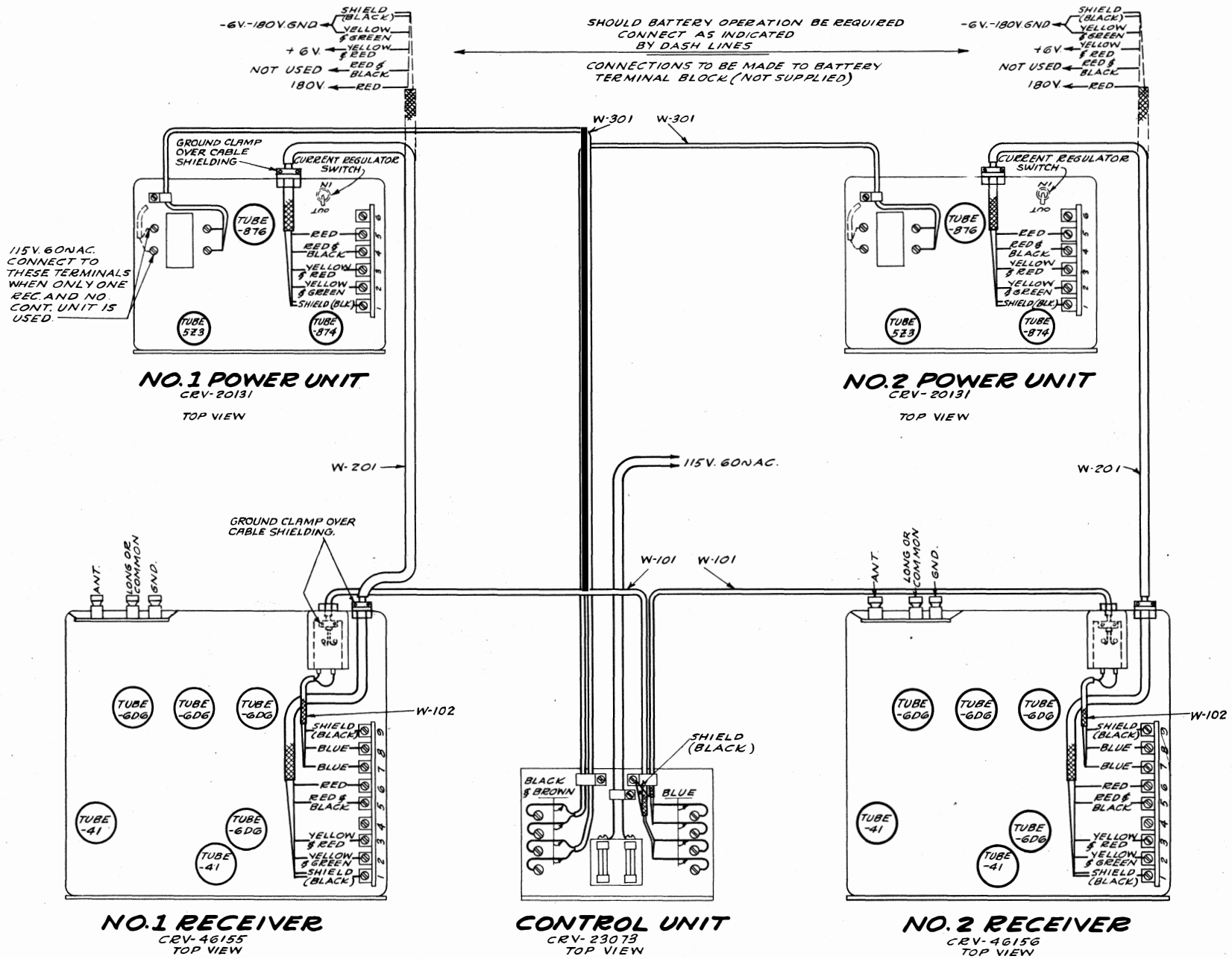

Figure 16—External Cable Connection Diagram  
(P-721267)



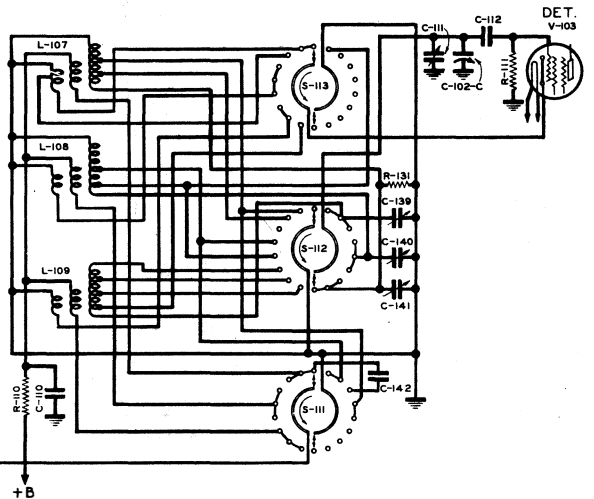
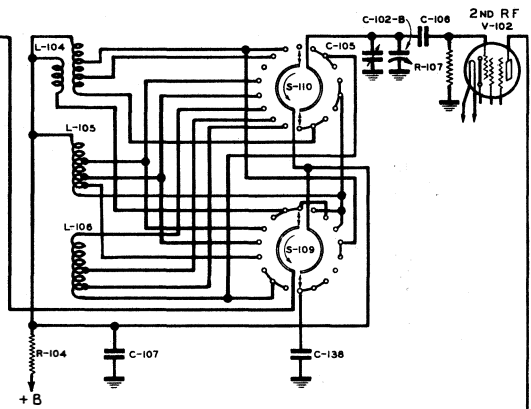
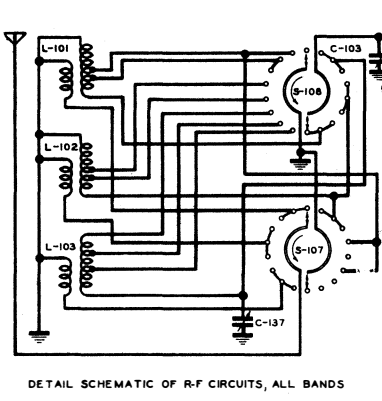
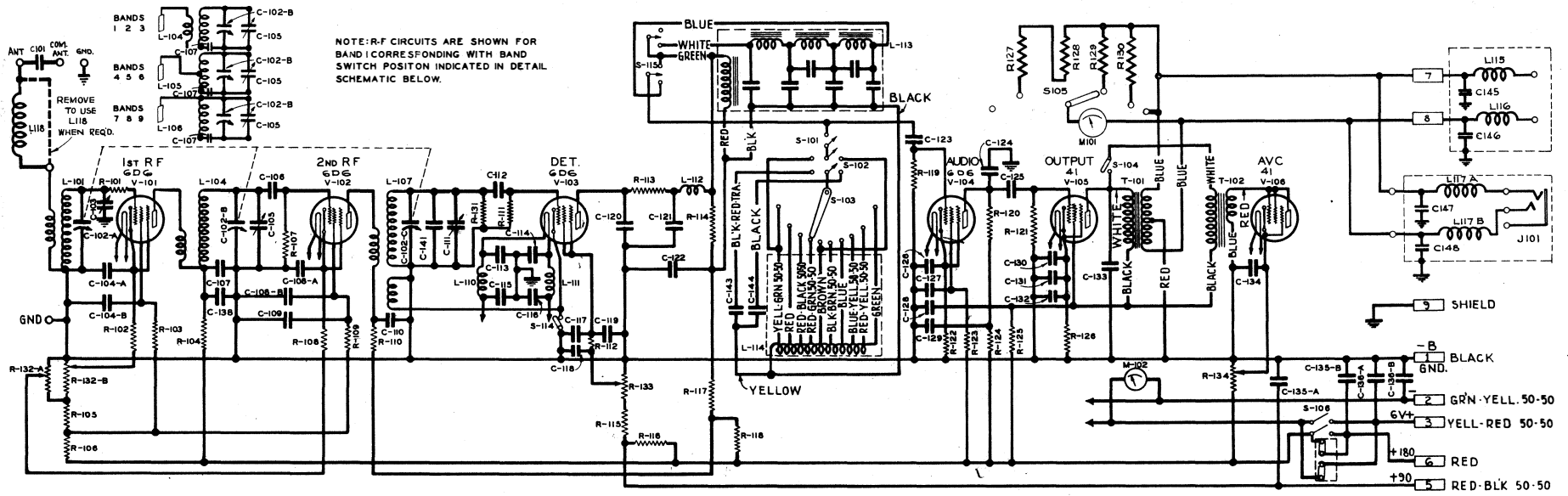

Figure 17—Schematic Diagram, Receiver Unit CRV-46156 (T-620490)



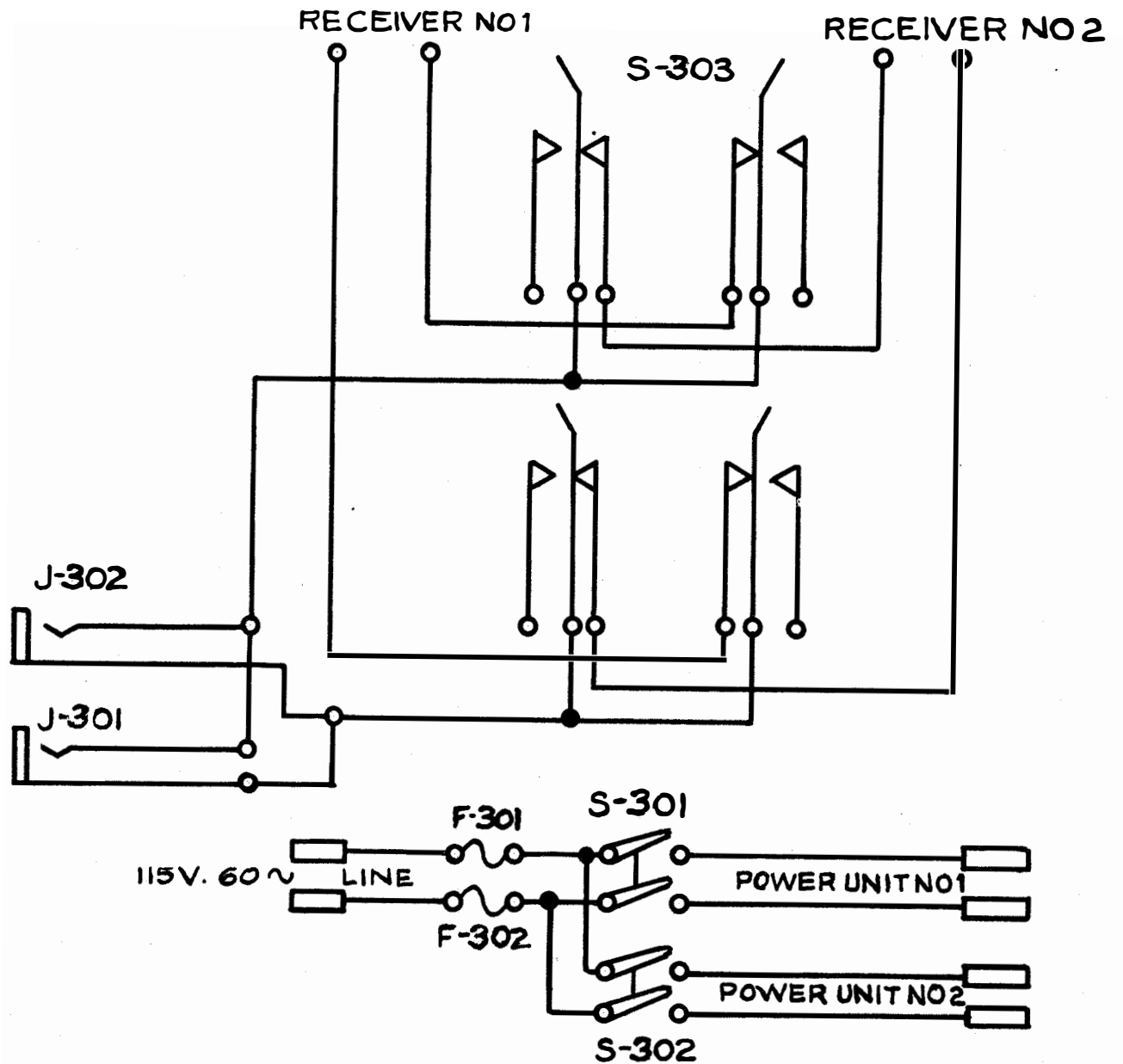

Figure 19—Schematic Diagram,  
Control Unit CRV-23073 (M-407021)

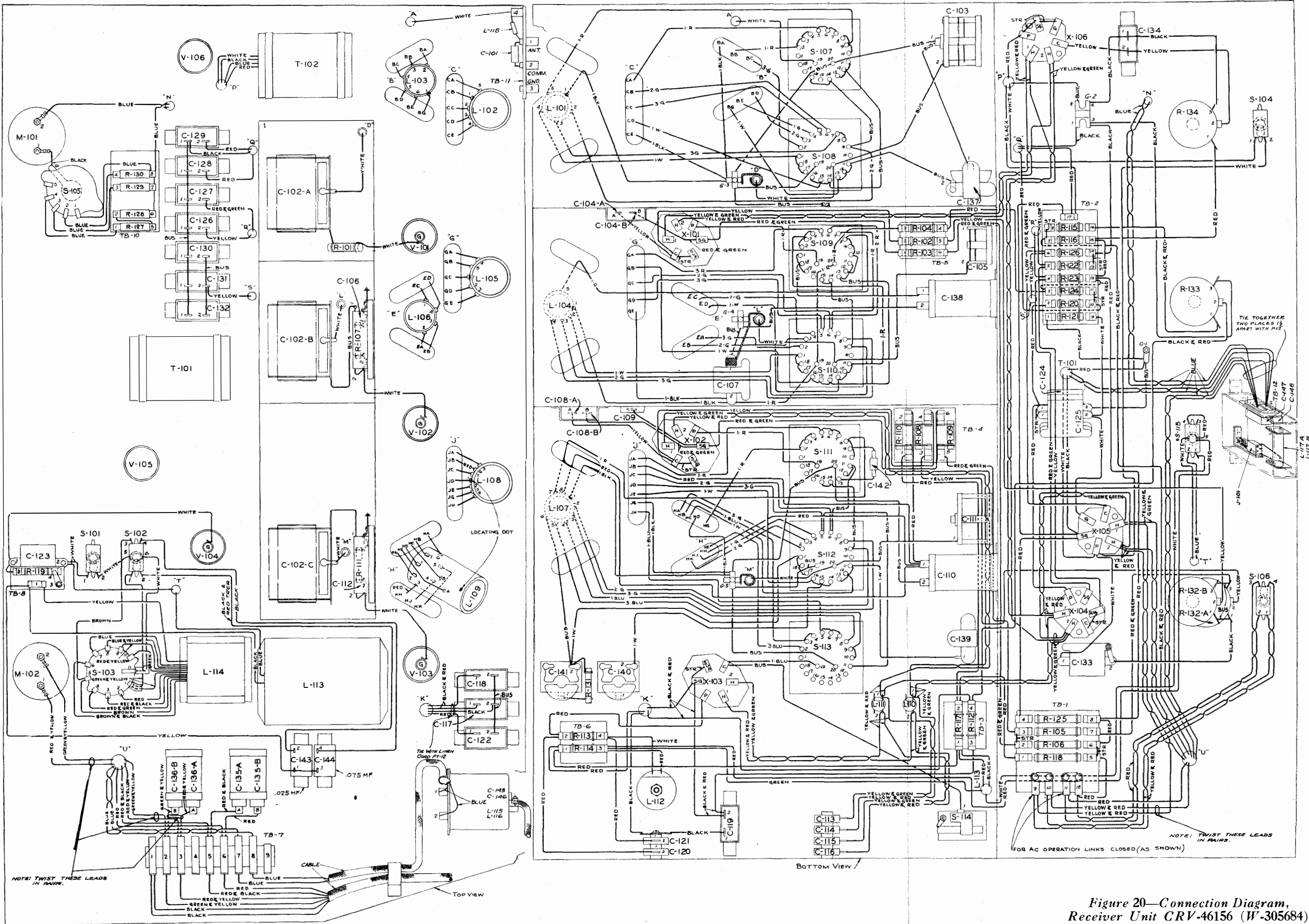

Figure 20—Connection Diagram, Receiver Unit CRV-46156 (W-305684)

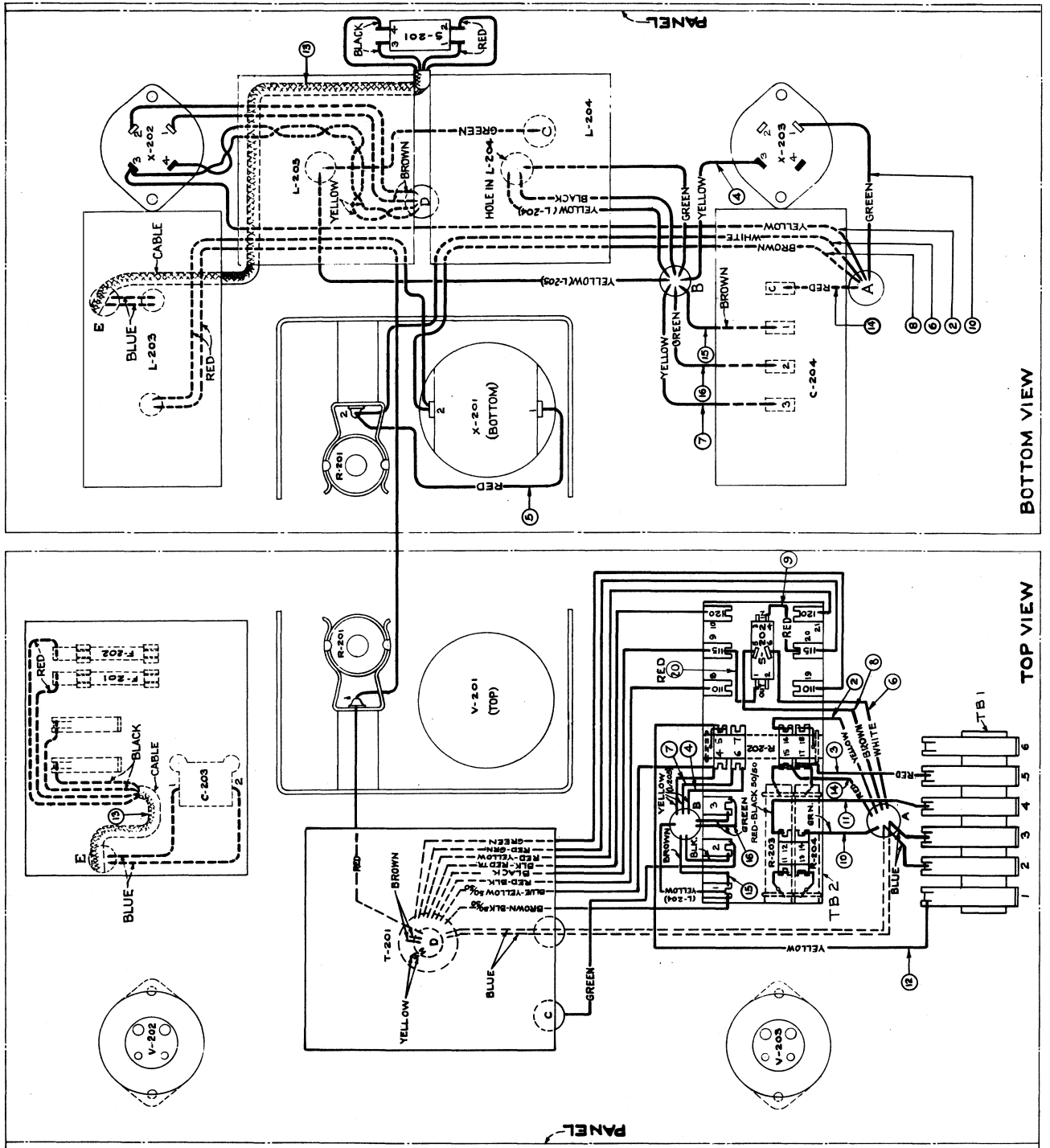

Figure 21—Connection Diagram,  
Power Unit CRV-20131 (T-620092)

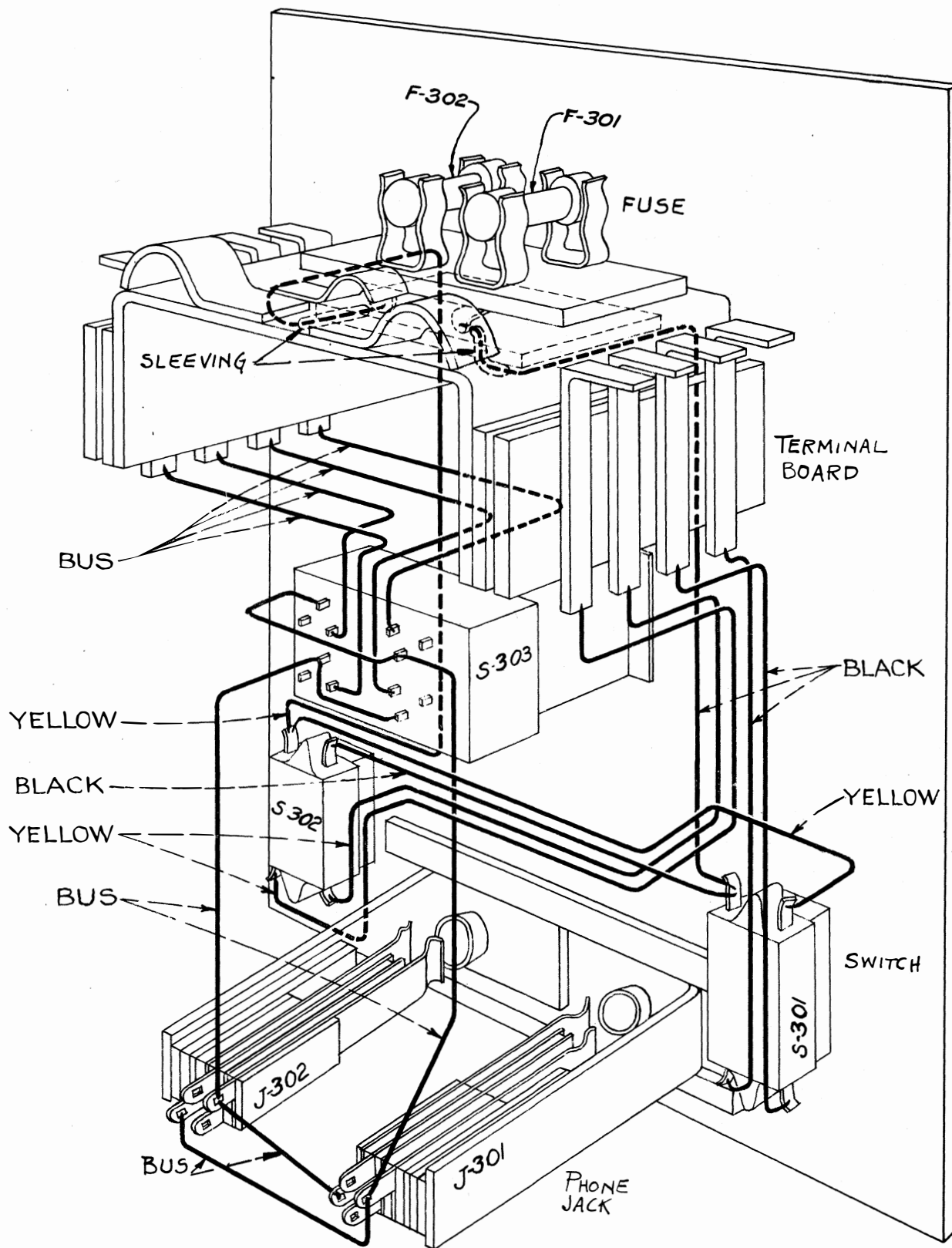

Figure 22—Connection Diagram,  
Control Unit CRV-23073 (P-714101)

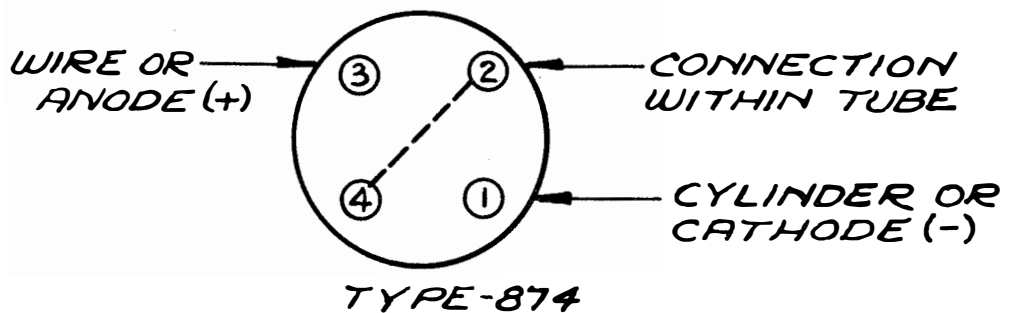
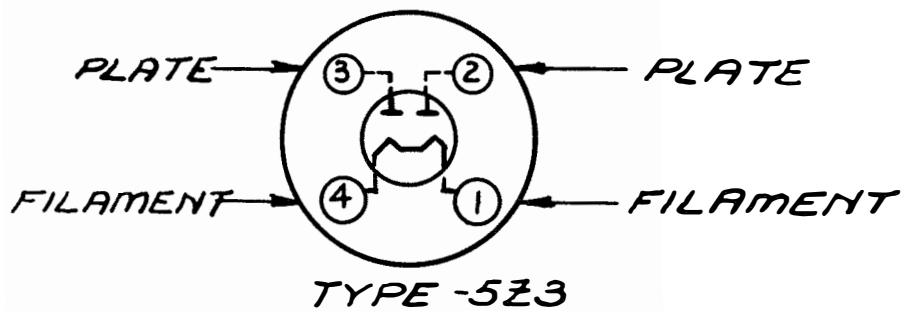
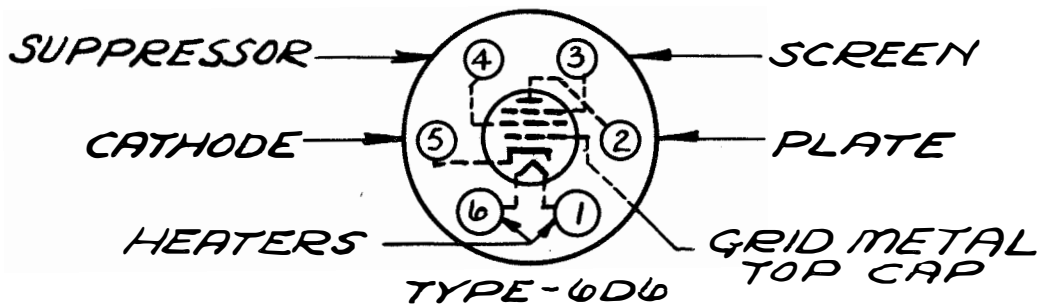
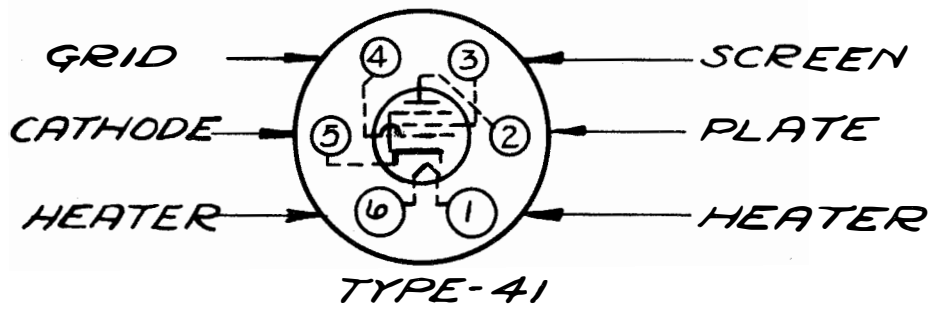

Figure 23—Tube Socket Connections  
 (K-850992)



