

NAVAL TECHNICAL TRAINING CENTER
PENSACOLA, FLORIDA
CRYPTOLOGIC TECHNICIAN CLASS "A"
CRYPTOLOGIC MAINTENANCE COURSE
(A-102-0109)

JOB SHEET 2.1.4A

TIME: 60

PHYSICAL LOCATION OF PARTS WITHIN THE RECEIVER & SIGNAL FLOW ANALYSIS

Note from the schematics, block diagrams, etc., that each part in the R-390A is designated by a 3 digit number (C-202, T-501, V-604, etc.). The R-390A is divided into several subchassis. Refer to the location chart on Page 17.

1. The front panel and mainframe of the R-390A is the 100 series subchassis. Any part, which has a part number beginning with "1" will be located on this subchassis (TB-102, K101, etc.).
2. The RF and Tunable IF section is the 200 series subchassis.
3. The 300 series subchassis is not used in this receiver.
4. The 2nd Crystal Oscillator is the 400 series subchassis.
5. The IF section is the 500 series subchassis.
6. The audio section is the 600 series subchassis.
7. The VFO is the 700 series subchassis.
8. The power supply is the 800 subchassis.

MATING OF PLUGS AND JACKS

Locate J-518 on the R-390A. Normally, you would expect P-518 to connect to this jack. What is the number of the plug connected to J-518? _____

1. Note that the last two digits match ... J-518/P-218.
2. The first digit of the jack, "5", tells you that the jack is physically located on the 500 series, IF, subchassis.
3. The first digit of the plug, "2", tells you that the signal on that cable comes from the 200 series, RF, subchassis.

LOCATING A PART ON THE SCHEMATIC DIAGRAM

Open your technical manual to the 4 page schematic diagram, pages 5-35 thru 5-46. Note that there is a "Zoning" list before each page of the schematic. Assume that you are looking for V-206.

1. Look in the zoning charts for a V-206 listing. You will find this on page 5-37. What are the zoning co-ordinates?

2. Look along the top, bottom and side borders of the schematic diagram.
- The number of the location co-ordinates will locate a vertical column, within which V-206 should be located.
 - The letter of the location co-ordinates will locate the tube vertically within the column. This procedure is identical to map reading.

NOTE: The filaments of the tubes are not drawn on the tube portion of the schematic. Check the zoning lists on each page of the schematic to see if V-206 is listed anywhere else. In most vacuum tube circuits, all filaments will be drawn in the power supply section of the schematic for the sake of simplicity.

After you have read the theory of operation, let's take a close look at the signal flow diagram located on pages 5-31 thru 5-34. We will take a signal at the antenna, and follow it completely thru the receiver. The knowledge gained from this brief analysis will aid you greatly in your troubleshooting, because you will know what frequencies to expect at the various stages.

For the purpose of our analysis, we will assume that our receiver is tuned to a signal at 5.237 MHz, using the unbalanced antenna. Open the technical manual to the signal flow diagram and trace along with us.

RF SECTION

- The 5.237 MHz signal from the antenna will pass thru antenna relay, K-101B and J-105/P-205 to contact #9 of switch S-205.

NOTE: Observe the dashed line connecting S-205, S-204, S-201, S-203, S-207, S-401, and S-402. These switches all change position when the MEGACYCLE CHANGE knob is turned. All switches will automatically be in the proper positions for processing a signal in the 5 MHz band.

- The RF signal will pass from contact #9 to contact #6 of S-205, be filtered thru the secondary of T-204, and be routed to S-204, contact #5.
- The signal, will pass to contact #8 of S-204, and be applied to the grid (pin 1) of RF amplifier tube V-201.
- The amplified 5.237 MHz signal at the plate (pin 5) of V-201 is routed thru S-206 (contacts #9 and #6) to filter circuits Z-204-1 and Z-204-2.
- From Z-204-2, the signal passes thru S-207 (contacts #6 and #9) to the grid (pin 6) of the first mixer, V-202. The frequency of the RF signal is still 5.237 MHz at this point.

6. V-202 is a sum mixer. It accepts the RF signal (5.237 MHz) at the grid and a 17 MHz signal from V-207 is applied to the cathode (pin 7). The signals at the plate (pin 1) are the two input signals, plus the sum and difference frequencies (11.763 MHz and 22.237 MHz respectively).
7. Z-213 will be tuned to pass the 22.237 MHz sum frequency, and reject all others. From Z-213, the 22.237 MHz signal passes thru S-208 (front) to the grid (pin 6) of the second mixer, V-203.
8. V-203 is a difference mixer. It accepts the 22.237 MHz signal at the grid, and a signal from the 2nd crystal oscillator at the cathode (pin 7).
9. To find the 2nd crystal oscillator frequency, notice that V-401 is tuned by S-401. Look up S-401 on page 5-41/5-42 of the schematic diagram. Note the numbers at the outside contacts of S-401. These numbers correspond to the band to which the receiver is tuned. We are tuned to a 5.237 MHz signal, so the switch will be making at contact #5 (between #4 and #6). Trace the wire back from contact #5 to Y-406, which is a 12.5 crystal. Therefore, our second crystal oscillator will be operating at 12.5 MHz, or a harmonic of this frequency. Return to the signal flow diagram.
10. If 22.237 MHz is mixed with 12.5 MHz at V-203, the resulting difference frequency will be 9.737 MHz. Note that Z-216 (at the output of V-203) will only tune from 3 to 2 MHz. Therefore, the 12.5 MHz fundamental frequency will not work.
11. If the second harmonic of the crystal is used, V-203 will mix the 22.237 MHz signal with a 25 MHz signal yielding a 2.763 MHz difference signal. Z-216 will pass this signal, and block the sum and the two original signals.
12. The 2.763 MHz output of Z-216 is applied to the grid (pin 6) of the third mixer, V-204. V-204 is a difference mixer, which mixes the incoming RF signal with a signal from the VFO, V-701. The VFO is tuned by the KILOCYCLE CHANGE control. To find the VFO frequency, proceed as follows:
 - a. Note that when the kilocycle portion of the frequency readout dial reads 000, the VFO is set at a frequency of 3.455 MHz.
 - b. As the KILOCYCLE CHANGE control is advanced each kilohertz, the VFO frequency decreases 1 kHz. When the frequency readout dial reads +000, the VFO output is 2.455 MHz.
 - c. Since our receiver is tuned to an RF signal at 5.237 MHz, the VFO output will be 3.218 MHz (3.455 MHz - .237 MHz).
13. The output of the third mixer, V-204 is the difference between our 3.218 MHz VFO signal at the cathode, and the 2.763 MHz RF signal at the grid. The 455 kHz difference frequency is passed by T-208, and the two original frequencies and the sum frequency is blocked from entering the IF circuits.

NOTE: No matter what frequency the receiver is tuned to, the output of the RF circuits must be 455 kHz for the signal to be heard.

Let's tune up a signal at a frequency of 3.854 MHz and see what develops.

What frequencies would you expect to find at the following test points?

Grid (pin 6) of V-202_____

Cathode (pin 7) of V-202_____

Grid (pin 6) of V-203_____

Cathode (pin 7) of V-203_____

Grid (pin 6) of V-204_____

Cathode (pin 7) of V-204_____

T-208 output _____

Take a well-earned break before analyzing the IF and audio circuits.

IF/AUDIO SECTION

If you have followed our circuit analysis so far, you should have little difficulty following our signal thru to the end of the receiver. The difficult task of finding oscillator frequencies is over. All of the IF circuits are fix-tuned to 455 kHz. Turn to the second sheet of the signal flow diagram (pages 5-33/5-34).

1. The balanced signal from T-208 arrives at the IF section at J-513 and J-518. Z-501 further filters the 455 KHz signal, preventing the VFO signal from being applied to the IF stages.
2. V-501 amplifies the 455 KHz IF signal and feeds its output to S-502, the bandwidth switch.
3. S-502 and S-503 determine which mechanical filter the 455 KHz signal must pass thru, thus determining the overall bandwidth of the receiver.
4. From S-503, the signal is:
 - a. Amplified by V-502
 - b. Filtered by T-501
 - c. Amplified again by V-503
 - d. Filtered by T-502
5. The output of T-502 splits into two lines
 - a. To V-504 for further amplification, for ultimate use as local audio and line audio.

- b. To V-509B for generation of AGC. We will consider the AGC circuits first. Then we will return to T-502 and follow the other path.
6. V-509B provides amplification and isolation of the 455 KHz signal. From V-509B, the signal is:
 - a. Routed to J-116 on the back panel of the receiver to provide an IF output for test purposes.
 - b. Applied to V-508.
 7. V-508 amplifies the IF signal. Its output is filtered by Z-503 and applied to V-509A.
 8. V-509A rectifies the IF signal, and provides a DC output that is proportional to the strength of the incoming RF signal. The output of V-509A is applied to V-506A.
 9. V-506A is used to determine the attack time and decay time of the AGC voltage. From V-506A, the AGC voltage is used to:
 - a. Control the gain of several RF and IF stages.
 - b. Drive the carrier meter to indicate the received signal strength.

NOTE: Attack time is the amount of time lag between the reception of a strong signal, and the time the AGC voltage reduces the gain of the receiver.

Decay time is the time lag between the disappearance of a strong signal, and the time the AGC voltage returns to its nominal value.

10. The second output of T-502 is amplified by V-504 and filtered by T-503.
 11. The output of T-503 is rectified by the detector, V-506B. The output of the detector stage is an audio signal, not IF.
- NOTE: The detector operates in the same manner as the AGC rectifier. When the BFO is on, it applies a 455 KHz (+ or - 3 KHz) signal into the detector. This signal will mix with the incoming 455 KHz IF signal, producing an audio tone as a difference frequency. This is how a zero beat is produced.
12. The audio output of the detector is routed thru the diode load jumper (on the back panel of the receiver) to V-507. The limiter normally operates as an amplifier, but it can be used to clip off (limit) excessive noise peaks.
 13. The audio signal is further amplified by V-601A. The audio then either passes directly to V-601B, or thru an 800 Hz bandpass filter.
 14. V-601B amplifies and isolates the audio signal. Its output is applied to the LOCAL GAIN and LINE GAIN controls.

NOTE The local audio channel and the line audio channel are functionally identical. Only the local channel will be covered.

15. The audio gain is determined by R-105. From R-105, the audio signal is amplified by V-602A and V-603.
16. The output of V-603 is coupled across audio transformer T-601. The audio output is simultaneously available at:
 - a. The headphone jack on the front panel of the receiver.
 - b. Terminals 6 and 8 of TB-102 on the back panel of the receiver.

This has been a superficial analysis of the signal flow diagram. For a more thorough analysis of any circuit, consult the appropriate section of the technical manual. Your instructor will explain any points that are unclear to you.

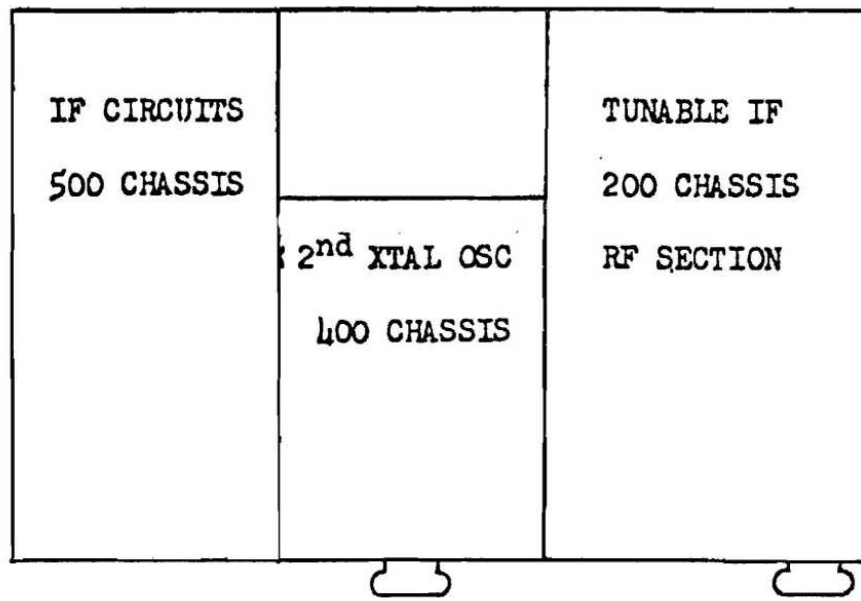

FRONT PANEL AND
MAINFRAME

100 CHASSIS

TOP VIEW

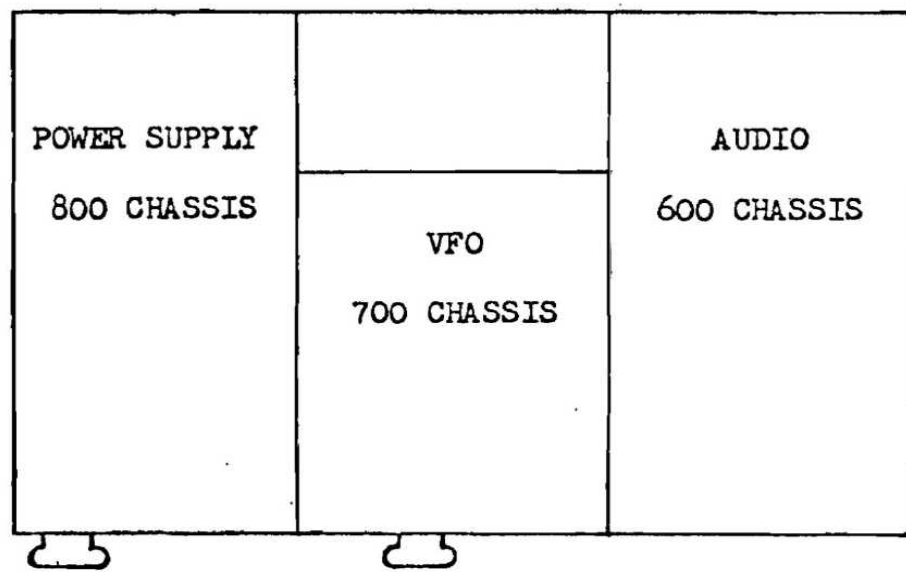

BOTTOM VIEW

NAME _____

CRYPTOLOGIC MAINTENANCE COURSE
CT'M' CLASS 'A' SCHOOL

WORK SHEET 2.1.4

R-390A/URR RADIO RECEIVER

The R-390A/URR is the standard HF receiver used throughout Security Group and has been proven to be a very reliable and extremely flexible piece of equipment. Since each station has several of these receivers, it would be inconceivable to think that you would not spend several hundred hours in the maintenance of this receiver. Learn it well now and save yourself a lot of time in the field.

BASIC COMMUNICATIONS RECEIVERS

Now that you have been acquainted with the theory of operation of the R-390A/URR, let's stop for a moment and see if the R-390A/URR theory corresponds with the basic receiver theory you received at ET'A' School. If you cannot correlate the two ideas, the alignment and troubleshooting of the R-390A/URR will prove meaningless.

General Terms

SENSITIVITY The ability of a receiver to amplify and detect a weak RF signal and produce a usable output. Actually, a receiver may appear to have good sensitivity because of an audible output, but the key actually is usable output which means it must be capable of driving external equipment. Normally, the sensitivity of a receiver is measured in the number of microvolts of input signal needed to raise the receiver output level 10 dB over the predetermined minimum noise level.

SELECTIVITY The ability of a receiver to differentiate between adjacent signals. A receiver with good selectivity may be able to receive a signal even with other signals close by in the frequency spectrum. In other words, it selects one narrow band of frequencies and rejects, or 'blocks out', all unwanted signals.

SUPERHETERODYNE
RECEIVER

This type of receiver converts the incoming RF signal to a lower intermediate frequency (IF), without losing any of the signal's intelligence. Matmen often mistakenly think of a superheterodyne as meaning a high gain receiver. Actually, the receiver does possess high gain (as do all types of good receivers), but the term implies that we have changed the incoming RF signal from, say, 20 MHz to a lower IF of, say, 455 KHz. In other words, we have to 'heterodyne' (mix) the incoming RF signal with local oscillator signals to convert the frequency down to a lower IF. The number of times a signal is heterodyned determines the number of 'conversion stages'. The R-390A/URR uses two stages of mixing for some frequency ranges (double conversion) and three stages of mixing for others (triple conversion).

Basic Block Diagram

Although the R-390A/URR (or any other receiver, for that matter) may seem somewhat 'fancy', it still has the basic sections shown in Figure 1.

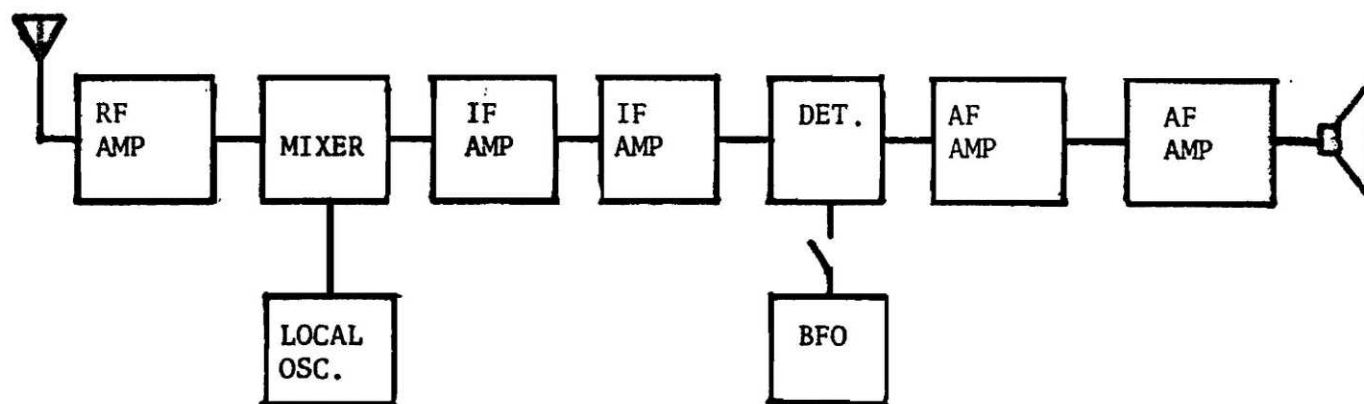

Figure 1

TYPICAL SUPERHETERODYNE RECEIVER

Notice that the incoming RF signal has been taken and reduced to an IF (and eventually audio) by using the mixer's difference frequency.

We could have used the sum frequency by employing filters designed for those frequencies, but this is seldom done because of the difficulties in designing stable, tunable circuits at higher frequencies.

One very important point needs to be brought out at this time - the fact that the selectivity of the receiver improves as the signal progresses through the receiver. In other words, the IF section ultimately determines the selectivity of the receiver.

On the receiving antenna, we have signals of just about every frequency present. After the signals pass through the RF section, we may have increased the selectivity to about 100 KHz for any given center frequency. We will continue to narrow this bandpass by using filters, usually located after the mixer stages. Eventually the signal will progress to a final filter in the IF section which may be 8 KHz wide, for example. This would be the final bandwidth, having been reduced from roughly 100 kHz in the RF stages to 8 KHz in the IF.

Uses

As stated previously, a receiver takes an incoming RF signal and converts it to an audio signal. We can use this audio signal for headset listening or for driving external equipment. The "external" equipment will frequently be a frequency shift converter that, basically, takes the receiver's output and converts it into a stream of DC pulses that would be used to drive (operate) a teletype or similar circuit. A typical system is illustrated in Figure 2.

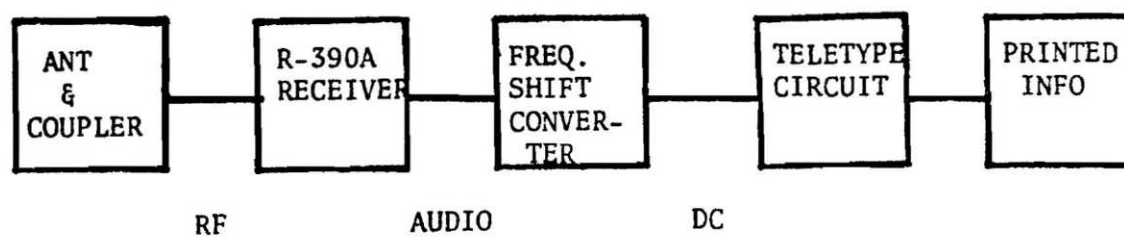

Figure 2

You may note that in place of the teletype (TTY) circuit, we could have substituted an entire computer system. It doesn't matter what the following systems are - without our basic receiver 'picking up' the incoming signals, our TTY and computer would be useless. We might as well pack up and leave without our receivers working!!!

R-390A/URR LABORATORY PROCEDURES

An instructor will assist you in the operation of any equipment required which you have not studied.

Read each step in its entirety before commencing the procedures outlined.

Observe all appropriate safety precautions at all times. If in doubt, consult an instructor prior to proceeding.

STEP 1 TEST CALIBRATE AND TUNE

NOTE: Perform Information Sheet 2.1.4 before proceeding.

- a. Have your instructor provide you with an R-390A/URR receiver and a tool box.
- b. Obtain the materials/equipments listed on MRC 2.1.4A. Your instructor will aid you if necessary.
- c. Carry out the procedures listed on the MRC while observing all proper safety precautions.

NOTE: Be sure to make note of any discrepancies. Any time the receiver fails to properly fulfill any of the procedures listed on the MRC, corrective action is indicated. Refer any discrepancies or difficulties to your instructor.

- d. Have your instructor check your work prior to proceeding.

Instructor Signature

STEP 2 PREVENTIVE MAINTENANCE

In this step you will perform a preliminary sensitivity check. It is designed to tell you a number of things about the overall operation of the receiver, especially when coupled with the results you garnered in Step 1. For example, if the sensitivity of the receiver is acceptable below 8 MHz but not acceptable above that frequency, you should be able to determine from the block diagram and schematic approximately where your area of difficulty lies. If for example the

calibrate procedure shows that the carrier signal cannot be tuned in any of the particular bandwidth positions, you may well have problems in one of the mechanical filters or the bandwidth switch. Whenever the receiver fails to perform any given function properly, trouble is indicated. Don't ignore little indicators of this kind.

CAUTION: Always observe safety precautions when making connections to equipment. Prior to applying power to equipment, set all controls in accordance with directions contained in the equipment technical manual. Allow adequate warm-up time prior to proceeding.

- a. Obtain the equipment/materials listed on MRC 2.1.4B and MRC 2.1.4C.
Your instructor will aid you if necessary.
- b. Carry out the procedures listed on the MRC's while observing all proper safety precautions.
- c. Record your results for MRC 2.1.4C below. Also make note of any difficulties or discrepancies encountered.

NOTE: Antenna Simulator SM-35 should be used when taking sense checks. Good RF bands should give readings of 3 uv or better per 10 dB change.

SENSITIVITY

1.1 MHz _____ uv	7.6 MHz _____ uv
1.9 MHz _____ uv	8.8 MHz _____ uv
2.2 MHz _____ uv	15.2 MHz _____ uv
3.8 MHz _____ uv	17.0 MHz _____ uv
4.4 MHz _____ uv	29.0 MHz _____ uv

- d. Have your instructor check your results.

Instructor Signature

STEP 3 CORRECTIVE MAINTENANCE

Before commencing corrective maintenance (CM), you should recall a few basic definitions and alignment principles. Previous to this step, we have performed only checks or preventive maintenance. Now we will commence with corrective maintenance - that maintenance requiring part replacement or alignment, or both, to restore the equipment to normal operating conditions. Even though your MRC checks may have been within specifications, you will perform CM for the experience needed in aligning other equipments.

As you will recall from your receiver training at Great Lakes, the correct procedure for aligning a receiver is to commence at the last stage and work towards the front of the receiver, finishing with the alignment of the RF amplifiers. The reason for this method is that the alignment meters and monitor jacks are usually located in the IF or audio stages. If there were a defect in the receiver between the RF stages and the IF/audio stages, we could not align the RF stages - the alignment points/meters would not operate properly. By going backward one stage at a time, we can align each stage, and be sure of getting a proper output from the receiver. If a proper output is not obtained, we would have to stop and troubleshoot that stage.

Mechanical Alignment

To ensure that all electrical alignment procedures will come out properly, it is best to first ensure that the mechanical train is in proper alignment. Do not skip any of the mechanical alignment steps!!! If the R-390A/URR is not properly mechanically aligned, then it can never be properly electrically aligned. You should have observed by now that the RF coil slugs are varied by the physical position of the mechanical cams. Remember - improper mechanical alignment will result in improper or no output. This should be the first step in any corrective maintenance action taken, particularly when the receiver will not calibrate below 8 MHz.

- a. Using the same receiver that you used in Steps 1 and 2 of this Worksheet, perform the alignment procedures as outlined in the following paragraphs of the R-390A/URR technical manual:

- (1) 6.2.1
- (2) 6.2.2
- (3) 6.2.3
- (4) 6.2.4
- (5) 6.2.5 (subparagraphs .3 and .5)

NOTE: Ensure the upper range of the KILOCYCLE dial counter reads '7+032'. If it does not, reset manually this time.

IF Alignment

To be sure that the receiver will adequately amplify and couple the desired signal, and have the proper bandpass, it must be aligned using specifically known frequencies. If you expect to receive specific frequencies accurately, the IF must be precisely tuned. At the same time, you must adjust the receiver for the desired bandwidths (that is, 455 KHz \pm 8 KHz, not 455 KHz, +6 KHz and -10 KHz).

c. Equipment/materials required

- (1) HF Signal Generator
- (2) Frequency Counter
- (3) Multimeter
- (4) dB Meter
- (5) Insulated hex adjustment tool
- (6) Phillips screwdriver
- (7) Alignment tool GC-5000 or equivalent
- (8) Adaptor, UG-636/U
- (9) Impedance adaptor (MX-1487 or equivalent)
- (10) Flat blade screwdriver
- (11) Headset

d. Set receiver controls as follows:

- (1) BFO switch - OFF
- (2) FUNCTION - MGC
- (3) AUDIO RESPONSE - WIDE
- (4) LINE METER - OFF
- (5) LIMITER - OFF
- (6) BANDWIDTH KC - 4 KC
- (7) RF GAIN - 10
- (8) LINE GAIN - 0
- (9) LOCAL GAIN - Midrange
- (10) Connect Headset

e. Procedure

- (1) Connect appropriate power cords to AC source.

NOTE: Dangerous voltages exist on the rear terminal strap of the R-390A/URR when the receiver is energized. Ensure the R-390A/URR is turned OFF when connecting test equipment.

- (2) Energize all equipments and allow adequate warm-up time.
- (3) Connect the dB meter to the receiver's LOCAL AUDIO output terminals on the rear panel (terminals 6 & 7) and set the meter to its highest range.
- (4) Connect the multimeter between the DIODE LOAD strap on the rear panel and ground. Set the meter controls to measure -DC.
- (5) Disconnect P-114 from J-514, P-213 from J-513 and P-218 from J-518.
- (6) Connect P-114 to J-513. (see your advisor for a special connector if your receiver does not have J-114).
- (7) Using a frequency counter, tune the signal generator to EXACTLY 455 KHz. Connect the signal generator output to J-116 on the rear panel of the receiver through the impedance adaptor.
- (8) Set the signal generator output for 150 uv., modulation OFF. DO NOT CHANGE THE SIGNAL GENERATOR OUTPUT FREQUENCY!!
- (9) Place the BANDWIDTH KC switch to the 2 KHz position.
- (10) Using the insulated hex alignment tool, adjust the cores of T-501, T-502, T-503, and Z-503 for a peak indication on the multimeter. Start at the back of the receiver's IF section and work towards the front. Use extreme caution when tuning the cores of these transformers. The slugs are made of powdered iron and damage very easily.
- (11) Remove the metal cover housing the mechanical filters on the left center of the IF subchassis. This will expose filter output trimmers C-568, C-569, C-570 and C-571. The filter input trimmers are available on the side of the receiver chassis. Refer to Figure 3 for component location.

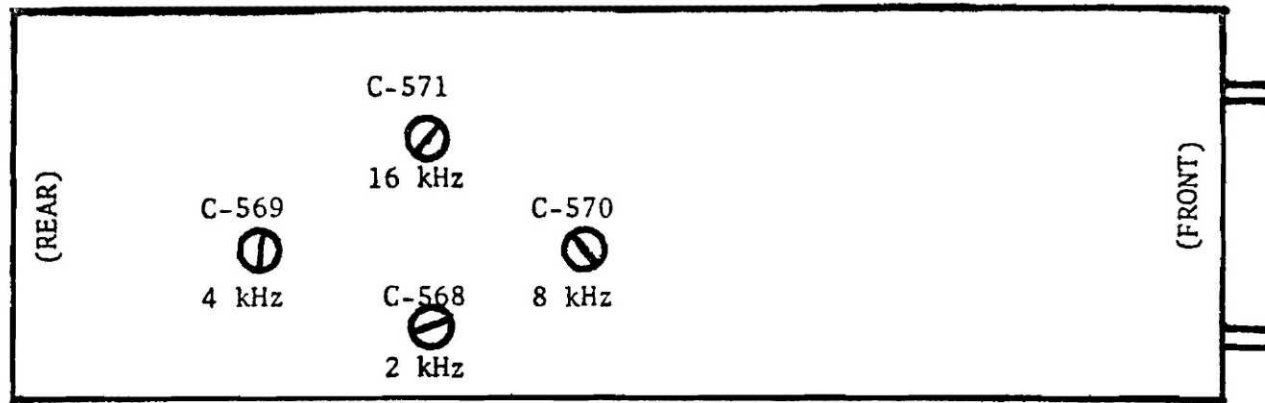

TOP VIEW OF THE IF CHASSIS

Figure 3

- (12) Place the BANDWIDTH KC switch to the 2 KHz position and tune C-568 for a peak indication on the multimeter. Set the BANDWIDTH KC switch to the 4 KHz position and tune C-569 for a peak indication on the multimeter. Repeat this for the 8 KHz and 16 KHz positions with C-570 and C-571, respectively.
- (13) Return the BANDWIDTH KC switch to the 2 KHz position and tune C-567 on the side of the IF chassis for a peak indication on the multimeter. Set the BANDWIDTH KC switch to the 4 KHz position and tune C-566 for a peak indication on the multimeter.
- Repeat the procedure for C-565 and C-564 on the 8 KHz and 16 KHz positions, respectively. Refer to Figure 4 for component location.
- (14) Return the BANDWIDTH KC switch to the 4 KHz position and set the IF GAIN adjustment, R-519, for a -7 VDC reading on the meter.
- (15) Leave the setup as is for the BFO calibration step.

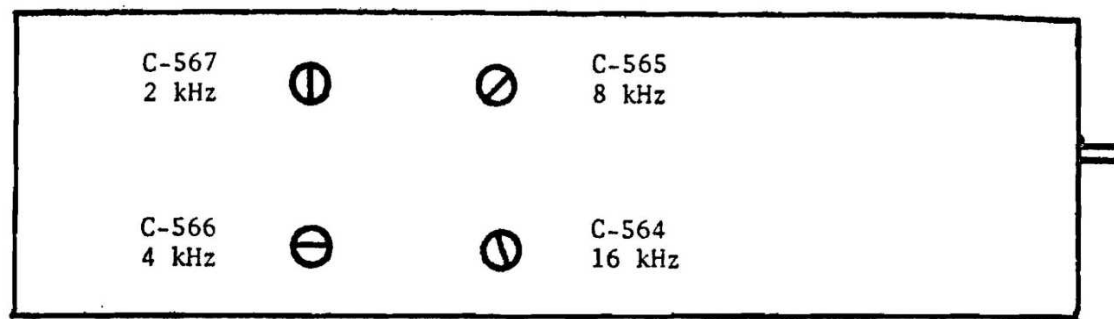

SIDE VIEW OF THE IF CHASSIS

Figure 4

BFO Calibration

Now that the IF has been correctly aligned to an exact 455 KHz, it would be a convenient time to adjust the BFO to an exact 455 KHz center frequency. In many applications of the R-390A/URR, the standard BFO knob is replaced with a calibrated indicator called a microdial. When this modification is used the BFO frequency is critical because the operator will depend on the microdial reading as being accurate to within a few cycles. The only way that can be true is for you to set the BFO frequency exactly during maintenance procedures.

f. Procedure

- (1) Turn BFO switch to ON.
- (2) Insert the headset into the PHONES jack. You should be able to hear a beat tone.
- (3) Tune the BFO PITCH to a zero beat. Place the LINE METER switch to its highest range. Using the BFO PITCH control tune for a null indication on the meter. Decrease the meter range and retune for a null. Repeat the procedure on the lowest meter range.
- (4) Loosen the BFO PITCH knob and adjust it so that the indicator points to \emptyset . Tighten the knob.
- (5) Disconnect the signal generator from the IF OUTPUT jack and disconnect P-114 from J-513.
- (6) Connect P-114 to J-514, P-213 to J-513 and P-218 to J-518.

- (7) Have your instructor check your results for this and the preceding steps. Notify him of any discrepancies.

Instructor Signature

Variable Frequency Oscillator Alignment

Now that the IF is accurately aligned to 455 KHz, it would be nice to know that you will be putting an accurate 455 KHz into the IF. A receiver's calibration can be only as accurate as the oscillator frequencies employed. If you expect to set the front panel controls to 6.235 MHz and receive that frequency with the utmost accuracy and efficiency, all internal circuits must be properly aligned to do so. Let's do it.

g. VFO Alignment

- (1) Deenergize the receiver.
- (2) Check V-701 in a tube tester for good GM. Reinsert the tube.
- (3) Remove VFO connector P-717 from J-217.
- (4) Disconnect P-116 from J-116 (IF OUTPUT jack).
- (5) Connect P-717 to J-116 then connect this output to a frequency counter.
- (6) Set the receiver at 7+000 MHz. There is a red separator that appears between the 7 and the KHz reading when reaching this frequency.
- (7) Tighten the ZERO ADJ knob, and center the KILOCYCLE CHANGE control at the midpoint between the two extremes of its movement.
- (8) Turn the receiver FUNCTION switch to MGC and check the VFO frequency. It should read 2.455 MHz \pm 1 KHz. If it does, proceed to step (12). If it does not, proceed to step (9).
- (9) On the Oldham coupler (located underneath the receiver on the VFO tuning shaft), loosen the clamp nearest the front panel.

- (10) Turn the section of the Oldham coupler still connected to the VFO until the frequency counter indicates 2.455 MHz.
- (11) Once the frequency is correct, retighten the front clamp on the Oldham coupler. Do not change the VFO setting while tightening this clamp!!!
- (12) Loosen the ZERO ADJ knob and tune the receiver to 7.000 MHz. The VFO output frequency should now read 3.455 MHz \pm 3 KHz. If not, contact your instructor.

NOTE: In most actual applications, the limits of error on the VFO frequencies would be much smaller than those listed above; however, the time consumed here to get the VFO exact is excessive in relation to the additional knowledge you would gain. Suffice it to say that the procedure is simple, as you have seen, but usually must be repeated many times before both ends of the VFO tuning range are within the exacting working tolerances required.

- (13) Turn the receiver OFF.
- (14) Reconnect P-717 to J-217 and P-116 to J-116.

Crystal Calibrator Alignment

Again, the only way to insure that the signal you are listening to is the correct one is to be sure that all oscillators in the receiver are accurate. The following procedure will see to that. The remaining procedures will employ the calibrate oscillator as a standard, and that standard must be accurate.

h. C-310 Adjustment

- (1) Set the FUNCTION switch to AGC with the RF GAIN control full CCW.
- (2) Adjust the CARR METER ADJ pot on the IF subchassis for a zero reading on the CARRIER LEVEL meter on the front panel.

NOTE: The adjustment of the carrier meter is important in the maintenance of the receiver because it is used in some of the more critical alignment procedures. You may also remember that the operator's tuning procedure (listed in paragraph 2.3.2.1) employs the carrier meter as one of the prime tuning indicators. Be sure that the preceding adjustment is very carefully done.

- (3) Connect the receiver to the STD FREQ OR SCALE OUT connector of an AN/USM-207A frequency counter. Adjust the counter for a 10 MHz output frequency.
- (4) Turn the RF GAIN control fully CW. Tune the receiver to 20 MHz and tighten the ZERO ADJ to keep the KC counter at exactly 20 MHz. Adjust the receiver for a peak indication using the KC CHANGE and ANT TRIM controls, while gradually reducing the BANDWIDTH KC to .1 KHz.
- (5) Set the BFO switch to ON and tune for a zero beat. Turn the LINE LEVEL meter switch to -10 and the LINE GAIN to about 5.
- (6) Using the BFO PITCH control, tune for a null indication on the LINE LEVEL meter. The receiver is now tuned to within a few cycles of 20 MHz.
- (7) Set the FUNCTION switch to CAL.
- (8) Use a screwdriver to adjust the CAL ADJ capacitor, C-310, through the rear panel access hole for exact zero beat, a null indication on the LINE LEVEL meter.

Crystal Oscillator Alignment

Now that the Cal Oscillator is finished, you can go back, to pick up where you left off earlier, around the crystal oscillator and variable IF.

i. Alignment Procedure

- (1) Recheck the synchronization of the crystal oscillator band switch.
- (2) Set the FUNCTION switch to STANDBY. Connect a multimeter to E-210 and set the controls to measure -DC voltage.
- (3) Turn the MEGACYCLE CHANGE control to 08 and adjust the corresponding trimmer for a peak indication on the multimeter.
- (4) Turn the MEGACYCLE CHANGE control to each band from 08 thru 31 and repeat the above procedure, trimming all appropriate capacitors for a peak indication on the multimeter.

NOTE: This procedure applies only to those frequencies above 08 MHz. There are no specific adjustments of the crystals for frequencies below 08 MHz since these bands use the same trimmers as the 17-24 MHz bands.

Second Variable IF Alignment

Now that the Crystal Oscillator has been properly aligned, it is safe to go into the IF that it feeds. Again, be sure that the frequencies you use are accurate.

j. Alignment Procedure

Refer to paragraph 6.2.10, page 6-11 of the R-390A/URR Technical Manual and perform the procedures described in paragraphs 6.2.10.1 and 6.2.10.2.

NOTE: Always tune the receiver to the signal generator output once the signal generator has been calibrated using a frequency counter. Tune the receiver to obtain a peak output on the multimeter connected to its diode load. Remember that you have already calibrated the oscillators and should receive a peak output at the proper point in terms of frequency.

First Variable IF Alignment

You may wonder why you are skipping any alignment procedure for the 17 MHz oscillator. Well that is primarily because there isn't any procedure to perform. If you check back to the schematic, you will note that there isn't any trimmer for that crystal so you can assume that it is correct if you are getting an output. It is a go-no-go type circuit. Therefore, you may proceed directly to the IF alignment procedure.

k. Alignment procedure

Refer to paragraph 6.2.11, page 6-12 of the R-390A/URR Technical Manual and perform the procedures described in paragraphs 6.2.11.1 and 6.2.11.2.

NOTE: When performing the alignment of the variable IF strips and the RF section you would do well to remember that the slugs are merely soft powdered iron pressed onto the brass shaft. Turning the slugs all the way in or out can cause you to torque the slug off the shaft. If you have a situation where the slug causes a peak indication when is turned all the way in or out, it usually indicates that the capacitor for the opposite end of the band is the probable cause. The slugs should show a peak indication while somewhere around the mid-point of their travel up or down the appropriate coil. If the slug tuning is causing a peak at the end of its travel, align the other end of the band first then return to the inductively tuned end of the band and readjust for peak indications. This will also insure flat response on that band rather than peaky response on one end of the band.

RF Coil Alignment

This is the next to last step in the overall alignment procedure of the receiver. As was noted above, avoid turning the RF coil slugs all the way in or out.

1. Alignment Procedure

Refer to paragraph 6.2.12, page 6-14 of the R-390A/URR Technical Manual and perform the procedures described in paragraphs 6.2.12.1 and 6.2.12.2.

Final Sensitivity Check

Now that all of the alignment procedures have been completed, it would be good for you to recheck the sensitivity to be sure that the alignment procedures were done properly. The sensitivity check is only a relative measurement by itself. You will be able to compare the sense of the high and low ends of each band to ensure that your alignment has not peaked one end of a band at the expense of the other. Figure 5 below indicates some of the conditions that can result from improper alignment along with a presentation of the proper response curve.

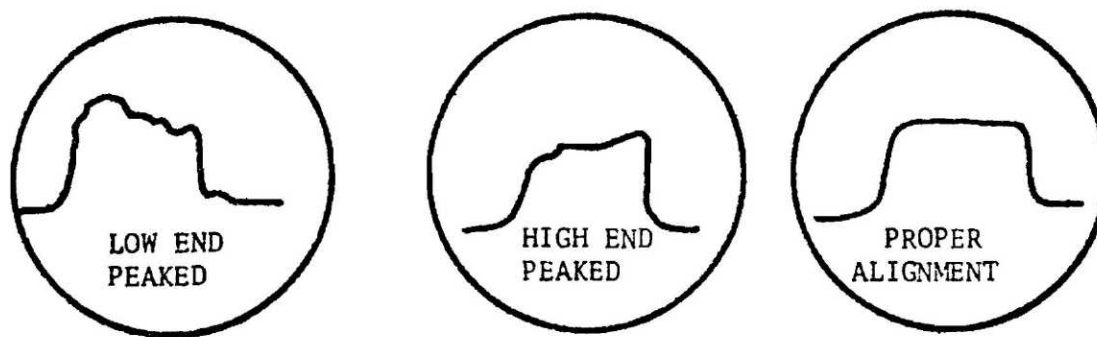

Figure 5

m. Procedure

- (1) Obtain the equipment/materials listed on MRC 2.1.4C. Your instructor will assist you if necessary.
- (2) Carry out the procedures listed on the MRC while observing all proper safety precautions.
- (3) Record your results for MRC 2.1.4C below. Be sure to note any discrepancies. They could indicate improper band alignment or malfunction.
- (4) Since sensitivity is a measure of how well a receiver detects and amplifies an RF signal, it is unnecessary to use a frequency counter to measure the frequency being fed into the receiver. Merely set the receiver to the frequencies listed below and tune the signal generator to the receiver. With the AN/PSM-4 Multimeter connected to the receiver's Diode Load, the meter will peak when both the receiver and generator are tuned to the same frequency. Fine tune to get the maximum peak from the multimeter by tuning the receiver's KILOCYCLE and ANTENNA TRIM Controls.

1.1 MHz _____ uv	7.6 MHz _____ uv
1.9 MHz _____ uv	8.8 MHz _____ uv
2.2 MHz _____ uv	15.2 MHz _____ uv
3.8 MHz _____ uv	17.0 MHz _____ uv
4.4 MHz _____ uv	29.0 MHz _____ uv

- (5) Have your instructor check your results.

Instructor Signature

STEP 4 SIGNAL OBSERVATION

You should now begin observing the R-390A/URR waveforms with a signal applied. This will help you in your troubleshooting and knowledge of the receiver. Read the following information carefully before proceeding to the procedure.

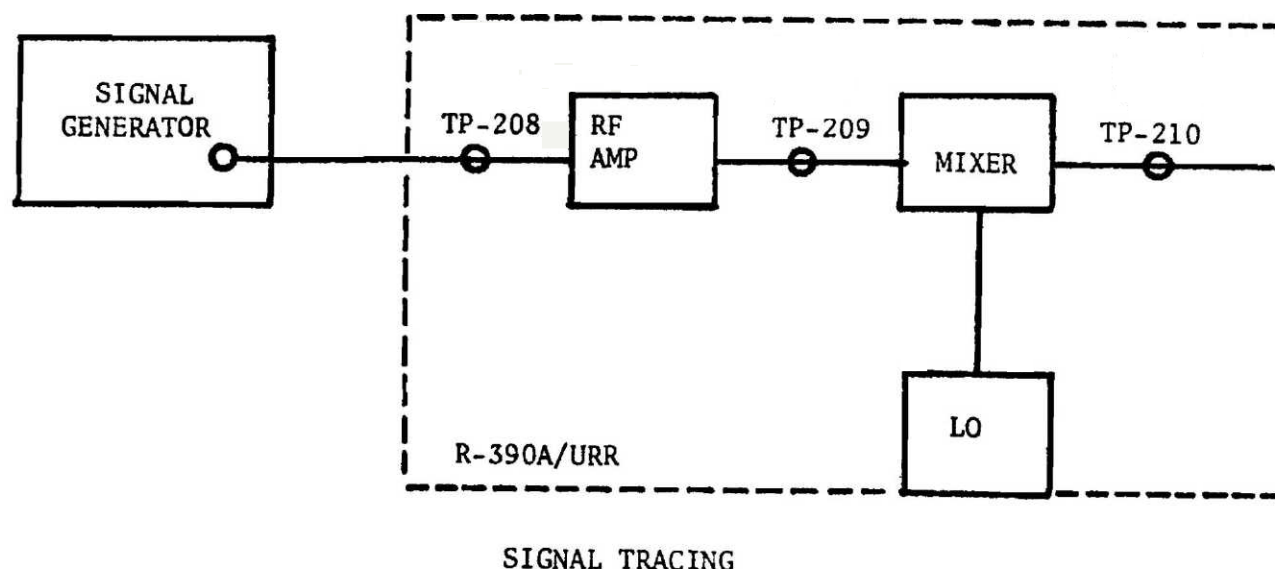

Figure 6

You will use the 'signal tracing' method of troubleshooting. It is the simplest of the established methods since the receiver does all frequency conversions once the signal within its operating range is applied.

Notice in Figure 6 that removing the signal generator from the receiver input causes the signal to disappear, or change, at TP-208. This means everything is working properly up to this particular test point. Reapplying the signal generator to the R-390A/URR brings the RF presentation back to the oscilloscope. You would have to continue on to find your problem, assuming one exists. The idea of placing the oscilloscope probe at TP-209, removing the signal generator input and checking for a waveform change continues throughout the receiver. Using this procedure, you can always isolate the problem between two known test points. For example, suppose you have the signal change at TP-209 when removing the signal generator but have no change at TP-210. Where is the trouble source? Right!! Either the mixer or the local oscillator input is bad. Using the signal tracing method, you have isolated the problem between TP-209 and TP-210.

Keep in mind we have been using the term 'signal change' when referring to the observed oscilloscope presentation. Often there will be oscillator

signals present in addition to the applied test signal at a given test point. Removing the signal generator input does not eradicate the oscillator signal. Students who observe the test points without removing the test signal often observe an oscillator signal and erringly assume they have the input test signal. Therefore, always disconnect the jack located between the oscillator and the test point under observation. Don't forget to reconnect it after observation and before proceeding to the next test point.

One further point on signal tracing: You will be applying much greater signal amplitude to the receiver than you would receive off the air. The receiver is designed to receive three microvolts or better but obviously, you could not see this with an oscilloscope. If a component is defective in a receiver, there will be weak or no signals present. For signal tracing, you must apply on the order of 40,000 microvolts (.04 volts) to actually observe the test signal on an oscilloscope. You probably will be able to hear this signal but only because you are greatly overdriving the receiver. It does not mean your receiver is good all of a sudden!! As a matter of fact, you may have to decrease the signal generator output at times when working with the IF stages and audio section because the great gain in these sections will often pass too large a test signal through a defective stage.

- a. For scoping the receiver, set the signal generator to 5 MHz with 1,000 Hz modulation at 30%, and tune the receiver for maximum out.
- b. Using an oscilloscope, observe the waveform at test point E-208 (refer to the signal flow diagram, figure 5-12, page 5-31/32 of the R-390A/URR Technical Manual).
- c. Increase the signal generator output for displayed amplitude of 0.04 volts on the oscilloscope.
- d. Record the signal generator output amplitude.

_____ V

This is the output voltage level you should use for the remainder of this procedure.

- e. Continue with the procedure, observing the waveforms at the listed test points or tube pins.

WARNING: ENSURE THAT THE POWER IS TURNED OFF BEFORE INSERTING OR REMOVING THE TUBE EXTENDER.

FREQUENCY ESTIMATION

Measuring a particular frequency on an oscilloscope is an easy procedure if you can remember that frequency is the inverse of time. In other words -

$$f = \frac{1}{t}$$

For example, if you are in the .1 microsecond/division time base on an oscilloscope and you have one complete cycle per time division, then you can find the frequency by utilizing the equation -

$$\begin{aligned} f &= \frac{1}{t} \\ &= \frac{1}{.1 \times 10^{-6}} \\ &= 10 \times 10^6 \\ &= 10 \text{ MHz} \end{aligned}$$

Usually, a rough estimate of frequency of an observed waveform will be sufficient. Normally, the more cycles that are under observation, the more accurate the determination of the unknown frequency will be. Also, the less interpolation, the more accurate the frequency will be.

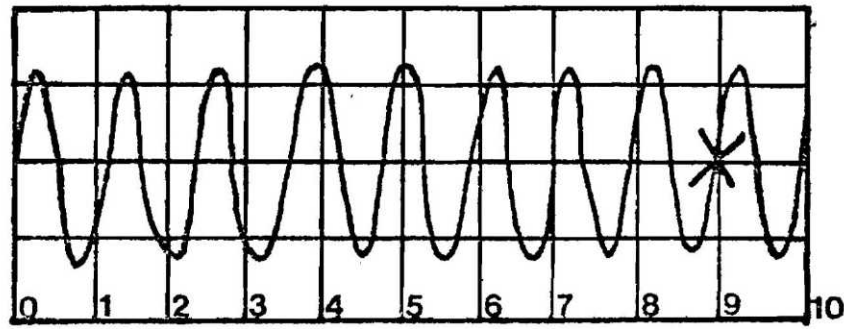

Figure 7

For example, with the oscilloscope time base in the 2 microsecond/division position, you can see in Figure 7 that there is not quite one

complete cycle per division of the test signal. You can make an approximation of this frequency with the equation now.

$$f = \frac{1}{t} = \frac{\text{number of whole cycles}}{\text{number of CM} \times \text{time/cm'}}$$

Given the example in Figure 7, the last whole cycle of the presentation crosses the X axis at the 9 CM mark, thus,

$$\begin{aligned} f &= \frac{8}{9 \times 2 \times 10^{-6}} \\ &= \frac{8}{18 \times 10^{-6}} \\ &= .444 \times 10^6 \\ &= 444 \text{ KHz} \end{aligned}$$

With this approximation of the frequency, you may conclude that this is the 455 KHz IF frequency signals. Notice again, you were close enough to the actual frequency to assume that it is the IF signal without having to use a frequency counter.

NOTE: At E-209 (V-202, pin 6) you may notice a signal even when the signal generator is disconnected. Often, the local oscillator signal from V-207, applied to the cathode (pin 7) of V-202, will capacitively couple across the tube elements of V-202 to the grid. To observe the RF signal alone, remove the oscillator tube from its socket while viewing the signal at the grid of the mixer. The same situation may occur at the second mixer (E-210/V-203) and the third mixer (E-211/V-204).

NOTE: You will not be using tube extenders in this application because the constant wear to the tube sockets causes the spring contacts and extender pins to break. However, in the field, where the receivers are not put to the abnormal wear and tear of a school environment, you would use tube extenders; in fact, you will use them here in the troubleshooting phase of this topic.

TEST POINT	WITH SIG GEN CONNECTED		WITH SIG GEN DISCONNECTED	
	FREQUENCY	AMPLITUDE	FREQUENCY	AMPLITUDE
E-209	_____	_____	_____	_____
J-221	_____	_____	_____	_____
E-210	_____	_____	_____	_____
J-415	_____	_____	_____	_____
E-211	_____	_____	_____	_____
P-717	_____	_____	_____	_____
P-213	_____	_____	_____	_____
DIODE LOAD	_____	_____	_____	_____

This list of test points will serve as a guide to you during troubleshooting. Since you know what the signals at these points look like when they are good, it should be easier to tell when they are NOT good. Proceed with the troubleshooting section below Good Luck!!!

STEP 5 TROUBLESHOOTING

- a. Re-read paragraph 5.2, Maintenance Turn-on Procedure, page 5-2 of the R-390A/URR Technical Manual. The information contained therein will prove helpful in your troubleshooting.
- b. Tell your instructor that you are ready to begin your troubleshooting. He will provide you with various problems in your R-390A/URR.
- c. You should utilize your Six Step Troubleshooting Procedure sheets for each of the problems. Step 1 of the procedure, SYMPTOMS, is probably the most important step. OBTAIN A COMPLETE SET OF SYMPTOMS. Don't just find one symptom and elaborate on that particular one, check for proper operation in all functions, bands and bandwidths.

The systematic way to troubleshoot the R-390A/URR is to use the overall block diagram, Figure 3-1, pages 3-3,4 of the Technical Manual. Using this block diagram, you should be able to initially localize the problem by observing the symptoms. Here's how.

No Audio Present in Headset. The problem will be located near the 'end' of the receiver (IF or audio sections). Also the associated power supply circuits or connections could be faulty.

Audio Present But No Calibrate Tone. This obviously means that something is defective in the RF section, VFO section and associated circuits, or the local oscillators. Keep in mind also that the mechanical alignment could be off.

Following the two procedures above, you should have a general idea in which area of the receiver the problem is located. Now look at the calibration oscillator in Figure 3-1. This calibration oscillator is the same as having a built-in test oscillator in the receiver for symptom recognition. Use it!!! Notice that it checks out the entire receiver except for the antenna relay and RF transformers. If the receiver calibrates, something obviously is defective prior to that stage.

You should also ask yourself the following questions:

- a. Does it calibrate below 8 MHz? Above 8 MHz?
- b. Is just one frequency defective?
- c. Is a whole band (for example 4-8 MHz) defective?
- d. Can it receive a signal from the signal generator, but it doesn't calibrate? Something in the calibrator oscillator could be bad in this case.
- e. Can I calibrate the receiver, but it doesn't receive a signal? You could have a bad antenna patch.

REMEMBER: Tubes are not the only items that might fail in a receiver. If you need to have access to under-chassis wiring, refer to the appropriate section of the Technical Manual for instructions on removing the individual subassemblies.

Using the preceding suggestions and your 'scoping sheet', commence your troubleshooting. Once again -- GOOD LUCK!!

The grading for R-390A/URR troubleshooting is 60% time and 40% for procedure. The problem time is based on an average time of the preceding students who have worked on that particular problem. Some of the problems are quickly found (25 mins) and some run for several hours. Don't ever give up. Your advisor will contact you when you have 'timed out' on a problem, so keep working until he stops you.

Fill your Six Step Troubleshooting sheet as you work on the problem. Not only does it assist your troubleshooting procedure, but counts 40% as mentioned before. After completing three problems, there is a five point penalty for an incorrect guess. There will be only defective components, unsoldered wires, loose clamps, etc., in your troubleshooting, so don't worry about any misalignment problems. It could very well happen in the field but we don't do it here.

Upon completion of your last problem, check your receiver to insure that it has no troubles, either intentional or accidental, left in it. Now you are ready to proceed with a sweep observation of your receiver.

STEP 6 SWEEP OBSERVATION

NOTE: If at any time you do not understand why you are performing a certain step, contact your Instructor.

- a. Obtain the following equipments/materials for the observation procedure:
 - (1) CAQI-8690B with CAQI-8698B plug-in unit
 - (2) Oscilloscope
 - (3) P-6006 probe w/clip-on tip and alligator ground clip
 - (4) Kay Model 30-0 attenuator pad
 - (5) Frequency counter
 - (6) Four BNC-BNC coaxial cables
 - (7) BNC-Alligator cable
 - (8) BNC 'T' connector/adaptor
 - (9) RF detector
 - (10) BNC-Banana connector/adaptor (if CBTv-545B scope is used)

Purpose of Sweep Observation

Sensitivity is only one measurement of receiver quality. Proper selectivity is another major consideration often overlooked in making receiver checks. If the bandpass of a receiver is too narrow (too selective), the operator will not be able to receive the signal he desires. If the bandpass of a receiver is too wide (not selective enough), unnecessary interfering signals will be received along with the desired signal.

Most selectivity and sensitivity in superheterodyne receivers is obtained in the IF section. The following procedures will be used to check the selectivity of the R-390A/URR receiver through the RF and IF stages.

NOTE: Certain malfunctions in the RF section of a receiver could adversely affect selectivity. A thorough check of any receiver necessitates a sweep check on every band. This work sheet will only cover sweeping in one band (4-8 MHz). Procedures for other bands would be identical.

b. Initial Set-up

- (1) Use a proper operating technique to calibrate the R-390A/URR to a frequency in the 4-8 MHz band. 5.1 MHz will be used in this work sheet. The actual frequency choice is optional.
- (2) Peak the calibrator signal with the ANTENNA TRIM control.
- (3) Set the R-390A/URR front panel controls as follows:
 - (a) FUNCTION - MGC
 - (b) RF GAIN - Full CW
 - (c) BANDWIDTH - 16 KHz
 - (d) BFO - OFF
 - (e) LIMITER - OFF
- (4) Do not alter the KHz or MHz tuning controls after the receiver has been calibrated.

NOTE: Refer to the diagram below, Figure 8, for clarification of the following steps.

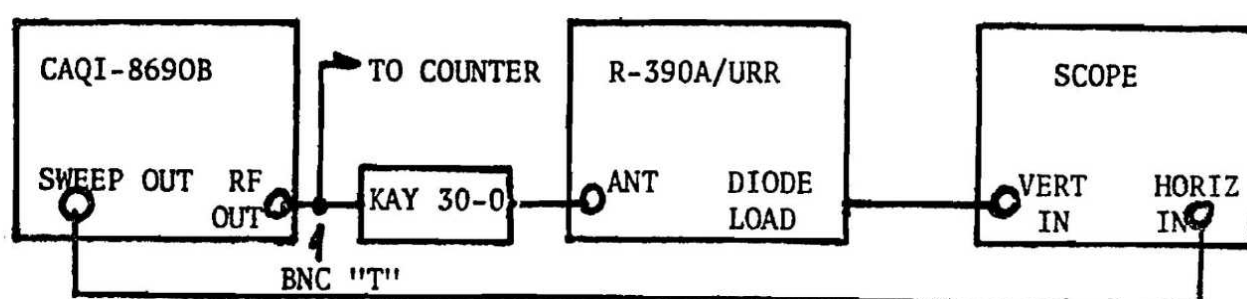

Figure 8

- (5) Since the CAQI-8690B outputs a swept RF signal from its OUTPUT jack, it would seem logical to connect the OUTPUT jack of the CAQI-8690B to the antenna input jack (balanced or unbalanced) of the R-390A/URR. The Kay Model 30-0 attenuator is inserted in the RF line to prevent overloading of the receiver.
- (6) As discussed in Topic 1.3.12, connect the SWEEP OUTPUT of the CAQI-8690B to the external horizontal input of the oscilloscope. Set the oscilloscope controls as necessary for use of external DC input.
- (7) The R-390A/URR employs an internal diode detector circuit. Therefore, no external detector is required for oscilloscope viewing. Using the P-6006 probe and accessories, connect the DIODE LOAD (on the rear panel of the receiver) to the vertical input of the oscilloscope. Set the oscilloscope vertical channel to DC input.

c. Sweep procedures

With the R-390A/URR controls set as in the previous steps, the bandwidth of the receiver should be 16 KHz. This means that the receiver should receive signals up to 8 KHz away (both above and below) from the center frequency. With a center frequency of 5 MHz, this would make the lower frequency bandpass (-3dB) point _____ and the upper frequency bandpass point _____. A properly aligned receiver will not only have the proper bandwidth, but will have one which is symmetrical about the center frequency.

- (1) Since the R-390A/URR is set to 5.000 MHz, set the CAQI-8690B controls as necessary to sweep automatically from just below 5 MHz to just above 5 MHz. Set controls as follows:

Function - START/STOP
 Power Level - +13
 Power Level Scale - X.1
 Sweep Selector - AUTO
 Sweep Time - .1 - .01
 Start/CW - approximately 4.9 MHz
 Stop/AF - approximately 5.1 MHz

- (2) Set the oscilloscope controls as follows:

Horizontal Display - approximately .5 External
 Vernier Sensitivity - approximately 20
 Horizontal Input Switch - DC
 Vertical Polarity - -UP
 Vertical Gain - As necessary to keep the presentation on the CRT

- (3) The presentation on the CRT should resemble that shown in Figure 9. If necessary, invert the oscilloscope vertical channel to obtain an upright presentation.

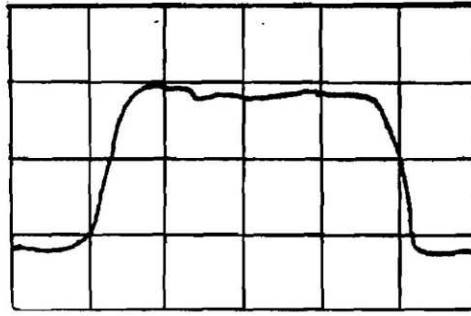

Figure 9

- (4) Increase the attenuation on the Model 30-0 attenuator pad. Note that the noise on the CRT presentation will decrease. Continue increasing the attenuation until a 3 dB change in attenuation is clearly visible on the oscilloscope (60dB or more of attenuation may be necessary).
- (5) Adjust the CAQI-8690B SWEEP TIME controls for a .01 sec sweep time (Range .1-.01, vernier control CW). Note the shape of the bandpass curve on the CRT.
- (6) Decrease the sweep time range switch to the 1 - .1 sec range (without moving the vernier control). Did the shape of the bandpass curve change? If so, why?
-
-
-
- (7) Leave the SWEEP TIME range switch in the 1 - .1 range for all future steps.
- (8) Insert 3 dB of attenuation on the Model 30-0 pad.

(9) Using the oscilloscope VERTICAL POSITION controls, place the highest peak of the displayed bandpass curve on the center horizontal graticule of the CRT.

(10) Remove the 3dB of attenuation.

(11) As described in Topic 1.3.12, since the peak of the bandpass curve moved upward 3dB from the center graticule of the CRT, the points where the bandpass curve now cross the horizontal center graticule are now 3dB below the peak. Now all that remains is to measure the frequencies of the two -3dB points.

NOTE: In Topic 1.3.12, you measured the bandwidth of the frequency markers of the CAQI-8690B, and found them to be approximately 10 KHz wide. Can these markers be used to measure the displayed receiver bandwidth? Why? Why not?

(12) Use the manual sweep techniques, outlined in Topic 1.3.12, to measure the upper and lower -3dB points of the bandpass curve.

NOTE: Be sure to disconnect the cable going to the counter while viewing the bandpass curve. Record your results below.

Upper -3 dB Point _____ MHz

Lower -3 dB Point _____ MHz

Bandpass _____ KHz

(13) Repeat the manual sweep procedures for the remaining bandwidth positions (8, 4, 2, and 1 KHz) on the receiver. Record your results below.

	8 KHz	4 KHz	2 KHz	1 KHz
Upper -3 dB Point	_____	_____	_____	_____
Lower -3 dB Point	_____	_____	_____	_____
Bandpass	_____	_____	_____	_____

STEP 7 CRYSTAL CHECK USING SWEEP GENERATOR

You are finished with your R-390A/URR, but let's try one more thing before you turn your toolbox back in. Almost any crystal can be checked by using a sweep generator and an oscilloscope. This could benefit you if you suspect that your receiver has a bad crystal, and you don't have another crystal to substitute.

Set up the test equipment as shown in Figure 10.

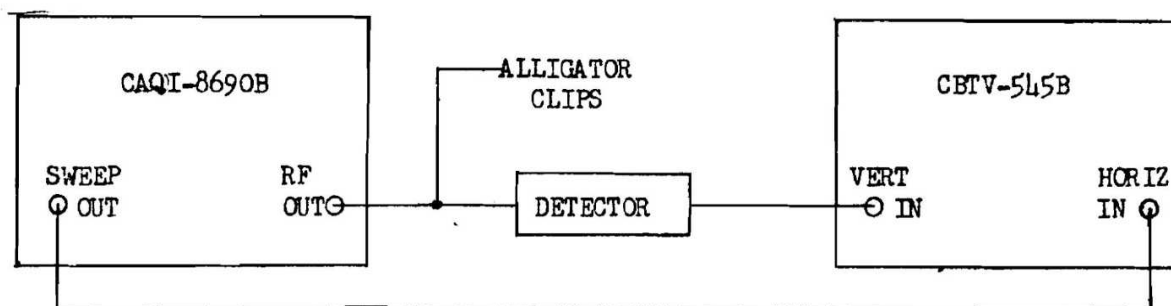

Figure 10

- a. Remove crystal Y-201 from the R-390A/URR and connect it across the alligator clips.
- b. Set the CAQI-8690B controls as necessary to sweep through the crystal frequency.
- c. If the crystal is good, it will act as a low impedance 'short' at its resonant frequency. This will cause a dip in the displayed waveform, as shown in Figure 11.

- d. What might be the cause of the 'ringing' in the displayed waveform?

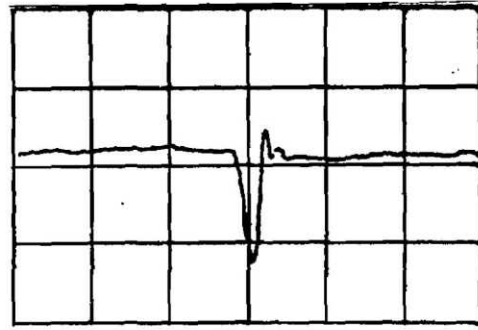

Figure 11

- e. Have your instructor check your results.

Instructor Signature

When you have completed all steps of this Worksheet, recheck the sensitivity of the receiver. If the sense is normal, place a tag (from Locker 2) with the receiver serial number, your name and the words 'Good Spare' on the receiver. Disconnect all cables and adaptors, secure all equipments and return all materials/equipments to their proper storage areas. Return your tool box.

Refer to Lesson Guide 2.1.4 and carry out any remaining directions.

R-390A CORRECTIVE MAINTENANCE FLOW CHART

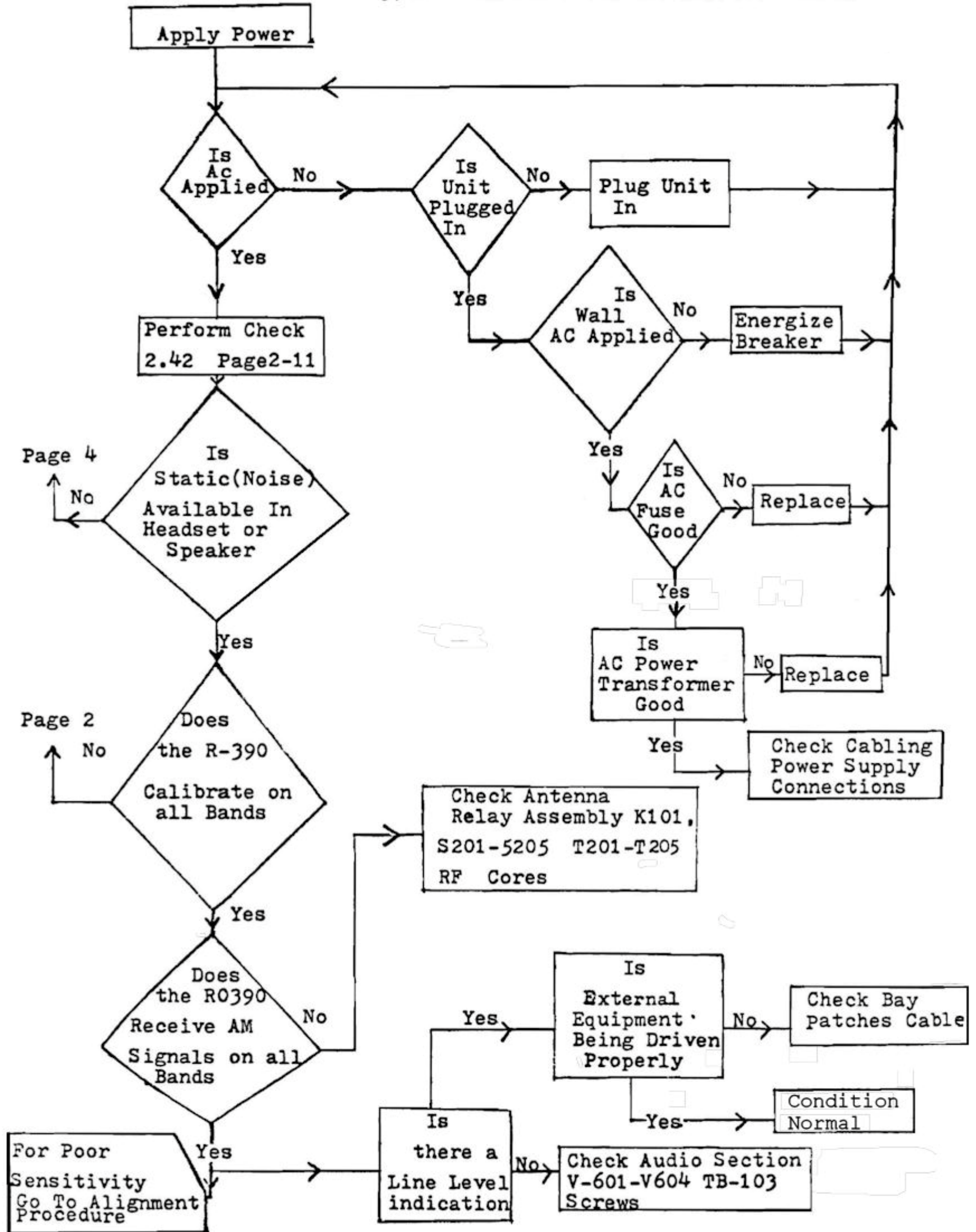

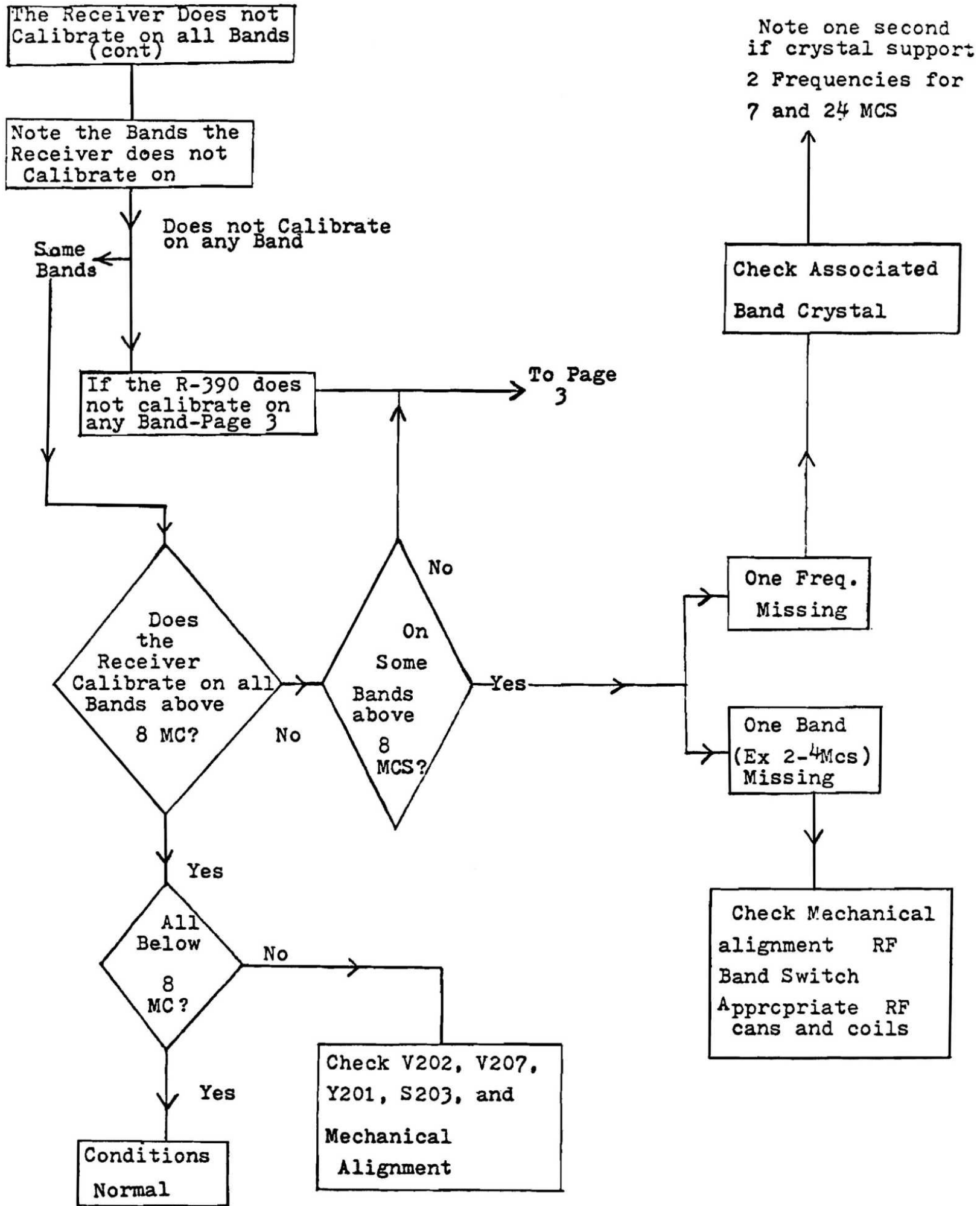

The R390 Does not Calibrate on any Band.

" The R390 A does not Calibrate on any Band."

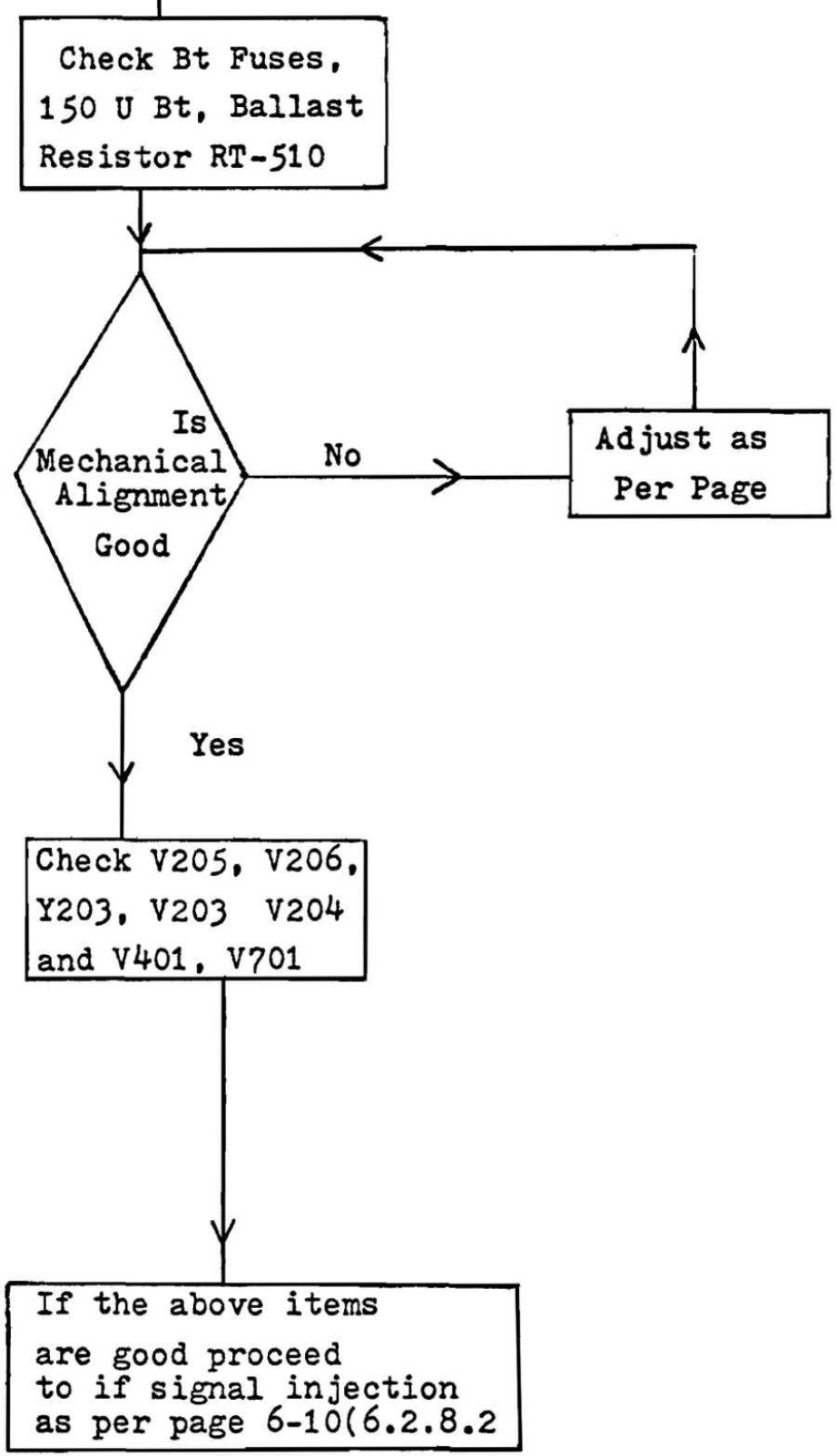

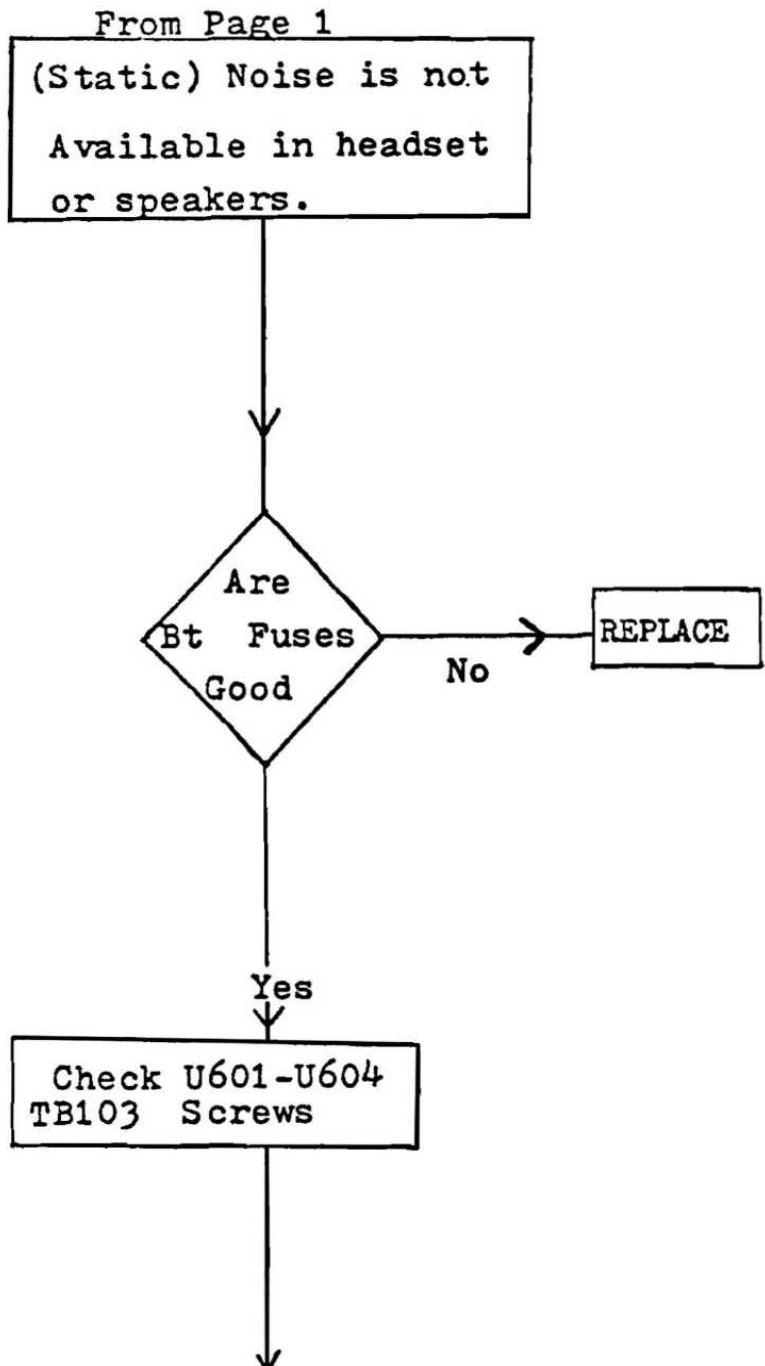

Note: If Static or noise

Level is not obtained:

- (1) The if Section (Step 6.2.8.2 Page 6-10) must be performed or
- (2) An audio section visual checkout Page 6-37 step 6.3.14 and signal injection must be performed.

Band (MC)	Position of switch S201 and range of antenna and ff coils (MC)	Position of switch S401	1st variable if range (MC)	2nd xtal-osc crystal freq. (MC)	2nd xtal-osc output freq. (MC)
0.5-1	0.5-1	0.	17.5-18	10.0	20.0
1-2	1-2	1	18-19	10.5	21.0
2-3	2-4	2	19-20	11.0	22.0
3-4	2-4	3	20-21	11.5	23.0
4-5	4-8	4	21-22	12.0	24.0
5-6	4-8	5	22-23	12.5	25.0
6-7	4-8	6	23-24	13.0	26.0
7-8	4-8	7	24-25	9.0	27.0
8-9	8-16	8	Not used	11.0	11.0
9-10	8-16	9	Not used	12.0	12.0
10-11	8-16	10	Not used	13.0	13.0
11-12	8-16	11	Not used	14.0	14.0
12-13	8-16	12	Not used	15.0	15.0
13-14	8-16	13	Not used	16.0	16.0
14-15	8-16	14	Not used	17.0	17.0
15-16	8-16	15	Not used	9.0	18.0
16-17	16-32	16	Not used	9.5	19.0
17-18	16-32	17	Not used	10.1	20.0
18-19	16-32	18	Not used	10.5	21.0
19-20	16-32	19	Not used	11.0	22.0
20-21	16-32	20	Not used	11.5	23.0
21-22	16-32	21	Not used	12.0	24.0
22-23	16-32	22	Not used	12.5	25.0
23-24	16-32	23	Not used	13.0	26.0
24-25	16-32	24	Not used	9.0	27.0
25-26	16-32	25	Not used	14.0	28.0
26-27	16-32	26	Not used	14.5	29.0
27-28	16-32	27	Not used	15.0	30.0
28-29	16-32	28	Not used	15.5	31.0
29-30	16-32	29	Not used	16.0	32.0
30-31	16-32	30	Not used	11.0	33.0
31-32	16-32	31	Not used	17.0	34.0

FIGURE 1

Modification of R-390A Receivers for SSB
Reception Without External
SSB Converter

By

Captain P. H. Lee, USN
NAVSEC - SEC 6171G
(W3JHR/N0AAB)

As originally designed, the R-390A HF receiver is usable to a certain extent for SSB reception without an external SSB converter, but it performs very poorly because the AM diode detector contributes considerable distortion. The relative levels of signal vs BFO injection voltage are not correct for proper SSB detection. The levels can be made more optimum by reduction of the R.F. gain, but then the AGC action is lost and weak signals are reduced so much that they are overlooked or unheard. The R-390A was designed to feed, an I.F. signal to an external SSB converter. However, by a simple and inexpensive modification of the internal BFO stage to a product detector, the R-390A can be made to perform as an excellent SSB receiver by itself, with no external converter being required for SSB. (For ISB, however, an external converter required, in the form of 2 CV-591s or 1 CV-157.) The modification is very simple, inexpensive, and does not require any contract procurement action, nor does it involve any proprietary designs. The modification requires less than 2 hours work by one man.

The parts required for the conversion are few and simple, and cost less than ten dollars [in the 1960s when this was written]. They are;

- 1 - 6BE6 tube.
- 1 - 2700 ohm 1 watt resistor.
- 1 - 11000 ohm ½ watt resistor.
- 1 - 56000 ohm ½ watt resistor.
- 1 - 5 MMFD 1000 VDC ceramic disc capacitor.
- 1 - 0.02 MFD 1000 VDC ceramic disc capacitor.
- 1 - 200 MMFD 600 VDC mica capacitor.
- 1 - 500 MMFD 600 VDC mica capacitor.
- 1 - 1.0 MFD 600 VDC paper capacitor.
- 1 - 4" length of insulating sleeve ("spaghetti"), about 1/8" I.D.

- 1 - Centralab® PA-2003 miniature ceramic rotary switch, 2 poles, 1 section, 2-6 positions. (For S101).
- 2 - Small soldering lugs.
- 1 - 72" length of shielded single conductor microphone cable, Alpha Wire No. 1703 or equal. (About 1/8" O.D.)

The conversion is performed as follows!

1. Remove the BFO B+ wires from the BFO ON-OFF switch S101. Remove and discard S101, but retain the knob.
2. Cut three 20" lengths of the shielded microphone cable. From one end of each of these three pieces, remove the outer plastic jacket and carefully unravel 1" of the shield braid and make a 1" pigtail lead of it. Twist the 3 pigtails together and solder them together, being careful not to melt the plastic insulation on the inner conductor of each piece of wire.
3. Take the new switch (only 2 of the 6 positions are used) for S101 in hand, and connect these three shielded leads to it to form the audio changeover circuit. See the schematic diagram. Under the head of the machine screw holding one side of the switch wafer to the switch frame install a small soldering lug. Solder the pigtail to it, to ground (at this end only) the individual shield braids of the 3 audio wires.
4. Insert the free ends of the 3 wires through the opening at the edge of the I.F. shelf, pull them upward above the I.F. chassis, and mount the new switch in the vacant S101 hole in the front panel. Replace the knob. Connect the BFO B+ wires to the other pole of the switch. The BFO B+ is to be ON in the BFO ON position, which will become the SSB position of S101. See the schematic diagram.
5. Unplug all plugs from the I.F. subchassis, mechanically disconnect the 2 control shafts, and remove the I.F. subchassis from the receiver.
6. Carefully remove the cable clamp and cover from multi-conductor plug P112, slipping it back out of the way. There is one spare pin, P112-1. Remove the wire from pin P112-7 and leave it hanging.
7. Twist the 3 shielded wires installed in step 2 into a 3-conductor cable, above the chassis. Wrap with plastic tape at 4" intervals. Cut this cable to the required length to reach plug P112, leaving sufficient slack for clearance over the I.F. chassis, and tubes. Strip back 1" of outer plastic jacket and, shield braid on each of the 3 wires. Run the 3 wires through the cable clamp and plug cover.

8. Connect the shielded wire from the SSB (BFO ON) audio terminal of S101 to pin P112-1. Use an insulating sleeve for protection, as is done on the other wires on the plug.

1. Connect the shielded wire from the AM (BFO OFF) audio terminal of S101 to pin P112-7. Use an insulating sleeve as in step 8.

1. Slip an insulating sleeve over the free end of the remaining wire, which should be the one connected to the rotary "arm" of S101. This is the "audio input" lead. Solder it to the free end of the wire left hanging in step 6. Slip the insulating sleeve down over the bare connection. Carefully replace the cover and cable clamp on P112. Tape these 3 wires to the existing cable just outside the clamp.

2. Turning the I.F. chassis over, carefully remove the bellows coupling on the BFO PITCH control shaft. Remove the shaft by loosening the panel bearing. This step clears some working space around the socket of V505 BFO tube.

1. Remove and discard the V505 6BA6 BFO tube.

3. Remove the ground (and all wires) from pin 2 of V505. This may involve shifting several ground leads to other ground tie points on the chassis.

4. Move the existing lead from V505 pin 7 to pin 2. (This is the cathode tap on the BFO coil Z502.)

5. In the following steps, be sure to leave room for replacing the bellows shaft coupling.

6. Connect the 11000 ohm 1/2 watt resistor from V505 pin 7 to ground.

17. Remove and discard C535.

18. Connect the 2700 ohm 1 watt resistor in parallel with the existing screen dropping resistor R529.

19. Connect the 5 MMFD capacitor between V505 pin 7 and V506B pin 6. This is the I.F. coupling into the injection grid of the 6BE6 product detector.

20. With a pair of small metal shears cut a 1/4" V-shaped notch in the lower edge of the interstage partition near the rear of the BFO coil Z502. Cover the edges of this slot with short pieces of plastic tape.

21. Mount the 200 MMFD and 500 MMFD capacitors on the grounded center post of the V506 socket, by merely letting them be supported in space by their own ground leads (about 1/4" long).

17. Connect the 56000 ohm 1/2 watt resistor between the free ends of the 200 and 500 MMFD capacitors.

22. Connect the 0.02 MFD capacitor from V505 pin 5 to the 500 MMFD end of the 56000 ohm resistor.

23. Use the remaining 12" of the shielded microphone cable for the SSB audio lead. Remove 1" of the plastic jacket from one end, and make a 1" braid pigtail on this end. Slip a 7/8" insulating sleeve over the pigtail and ground the pigtail to the center ground post of V506 socket. Connect the center conductor to the 200 MMFD end of the 56000 ohm resistor.

24. Lay the shielded wire in the V-shaped slot in the interstage partition, and tape it in position with a 2" length of plastic tape. Cut the wire to length to reach pin J512-1 of the rear cable socket. This is the unused pin. It mates with Pin P112-1 of the cable plug. Strip back 1/2" of the plastic jacket and braid from this end of the shielded wire. Connect the wire to pin J512-1, using an insulating sleeve over it for protection.

25. Carefully replace the BFO shaft and bellows coupling removed in step 11. Make sure the coupling does not accidentally ground any components or wiring.

26. Replace the I.F. subchassis in the receiver. Plug in all the plugs removed in step 5. Reconnect the 2 control shafts. Replace their front panel knobs. Make sure the BANDWIDTH knob is properly positioned on the shaft.

27. Plug in the 6BE6 tube in socket V505. Turn on the receiver. Leave the antenna disconnected.

28. With the BFO switch S101 in the ON (SSB) position, a hissing sound will be heard in the loudspeaker. With the bandwidth switch in the 1 KC position, rotate the BFO PITCH knob. The pitch of the hissing sound will vary from high to low and back to high again, as oscillator portion of the 6BE6 is tuned thru the center of the receiver I. F. bandpass. Set the BFO PITCH control for the lowest pitch of the hiss. Without rotating the shaft, loosen the knob set screw, and set the knob pointer to "0." The pitch of the hiss should now rise equally at the -1 and +1 positions of the control.

17. Set the BANDWIDTH knob at 2 KC, and at 4 KC. In each case, the pitch of the hiss will be lowest at the "0" position of the BFO PITCH control, rising an equal amount on each side (-1, +1 or -2, +2).

17. The original AGC action is not satisfactory for SSB voice reception. It is too fast in the FAST position and produces a "pumping" action. In the MED position it is a bit too slow for fast voice break-in operation. From the unused terminal 10 of AGC switch S107 (FAST position) connect the 1.0 MFD capacitor to ground. This may be done most conveniently by soldering one capacitor lead directly to the switch lug behind the front panel, and connecting the other lead to a ground lug placed under the R.F. section top cover screw just back of the center of the front panel. This places 1.0 MFD in series to ground with capacitor C551 (2.0 MFD) in the FAST position, making a total of 0.66 MFD across C548 in the grid circuit of V506A, the AGC time constant tube. The resulting time constant has been found by experimental use to be quite satisfactory, producing SSB voice signals which are pleasing to the ear to copy. For multiplex or composite waveforms of essentially constant amplitude, the MED or SLOW AGC may also be used, as desired.

32. The receiver is now ready to operate. Connect the antenna. With the AGC switch set at FAST, and BFO ON, tune in a SSB signal in the 14MC amateur band, with the BFO PITCH control set at -2, and the BANDWIDTH control at 4KC. It should sound very pure, clean, and undistorted (assuming the station's emission is clean and undistorted). The BANDWIDTH control may be set at 2KC for interference reduction, with the BFO PITCH set at -1 in this case.

33. Shift frequency to the 7 or 3.9MC amateur bands. Tune in signals here in the same way, but with the BFO PITCH set on the opposite (+) side of "0."

34. Most 14MC amateur emissions are upper sideband, whereas those on 3.9 and 7MC are usually lower sideband. Note that the BFO PITCH must be set to the opposite side of the carrier ("0") for reception of the desired sideband (- for USB, + for LSB). When you do this, you are in effect placing the locally injected carrier from the oscillator portion of the 6BE6 in the proper position for demodulation of the SSB signal and for positioning the signal correctly within the receiver passband.

CW may also be received with the BFO switch ON (SSB position), using BFO PITCH and BANDWIDTH controls as desired. For AM, the BFO switch is OFF, unless AM reception in the SSB mode is desired in which case it is ON.

The conversion is now completed, and the R-390A may now be used for SSB with no external converter.

This detailed information applies only to the R-390A. A similar conversion can be worked out for the R-390 or any other good superheterodyne receiver. It has been used with success in several Collins R-388 (51J) receivers and AR-88 receivers by the writer. In the R-388, the oscillator portion of the 6BE6 has been crystal controlled, with 3 crystals (1 for USB, one for exact I.F., and 1 for LSB) selected by a switch in place of the BFO PITCH control. Crystal control is not so practical in the R-390A because of the selectable I.F. bandpass. A multiplicity of crystals would be required.

NAVAL TECHNICAL TRAINING CENTER
PENSACOLA, FLORIDA
CLASS "A" COMMUNICATIONS TECHNICIAN
CRYPTOLOGIC MAINTENANCE COURSE
(A-102-0109)

NUMBER 2.1.4

TIME: 3,600 mins

I TOPIC: HIGH FREQUENCY (HF) RADIO RECEIVER, R-390A/URR

II OBJECTIVES: When you complete this topic you will be able to:

- A. State the purpose and use of the R-390A/URR
- B. Identify and describe the external controls, indicators and connectors of the R-390A, stating the function and operational effect of each
- C. State the functional block diagram analysis of the R-390A
- D. State the signal flow analysis of the R-390A
- E. State the functional description of the mechanical tuning system used in the R-390A
- F. Demonstrate the ability to manipulate the external controls of the R-390 for reception of any given frequency (signal)
- G. Demonstrate the ability to perform preventive maintenance on the R-390 in accordance with the Maintenance Requirement Card (MRC)
- H. Demonstrate the ability to perform corrective maintenance on the R-390 in accordance with worksheet WS-2.1.4

III INSTRUCTIONAL MATERIALS/AIDS and MEDIA

- A. MATERIALS--This lesson package contains the following materials
 - 1. Lesson guide number 2.1.4
 - 2. TECHNICAL MANUAL FOR OPERATION, MAINTENANCE AND INSTALLATION INSTRUCTIONS WITH PARTS LIST, RADIO RECEIVER R-390A/URR, NAVSHIPS 0967-063-2010
 - 3. Worksheet WS-2.1.4
 - 4. Maintenance Requirement Cards 2.1.4A, B, C
 - 5. Allowance Parts List #81039001

B. REFERENCE--

1. TECHNICAL MANUAL FOR OPERATION, MAINTENANCE AND INSTALLATION INSTRUCTIONS WITH PARTS LIST, RADIO RECEIVER R-390A/URR, NAVSHIPS 0967-063-2010

C. MEDIA--Self-study

- IV RELATED INSTRUCTOR ACTIVITY--The instructor will be available at all times while you are studying this topic. Any questions you have or any areas of the material which are not clear to you should be brought to his attention immediately.
- V RELATED STUDENT ACTIVITY--The student will cover the material contained in this lesson at his own pace and will be tested on the subject matter when he is satisfied that he can meet the requirements of the objectives.

INTRODUCTION

The R-390A/URR is one of the most commonly used HF receivers throughout the Navy, especially in the NAVSECGRU. You will be required to maintain this receiver at one time or another regardless of where you are assigned.

The R-390 is a superhetrodyne type receiver utilizing multiple frequency conversion to cover a frequency range of 0.5 to 32 MHz. Triple conversion is used from 0.5 MHz to 8 MHz and double conversion from 8 MHz to 32 MHz. Linear tuning provides constant frequency spread throughout the entire range and is accomplished by positioning powdered-iron cores in the RF and IF coils, at a rate controlled by a mechanical arrangement of gears, shafts and cams. A 455 kHz output is taken from the third IF stage for use with a sideband converter. There are also two audio outputs: LOCAL AUDIO with either 500mw to a 600 ohm load or 1 mw for a headset and LINE AUDIO with 10 mw to a balanced 600 ohm line.

Since the R-390A is so widely used it is extremely important that you thoroughly understand this topic. In addition, this is the first equipment in the course that you are required to troubleshoot, align and repair.

The Technical Manual for Radio Receiver R-390A/URR is the text for this lesson and you should preview its contents prior to continuing with the lesson.

A. PURPOSE AND USE

The purpose of the R-390A/URR is to provide reception of continuous-wave (CW), modulated-continuous-wave (MCW), frequency-shift-keyed (FSK), and single-sideband (SSB) signals.

It is used as a general purpose receiver in both shore-based and ship-board installations.

B. EXTERNAL CONTROLS, SWITCHES, INDICATORS

AND CONNECTORS OF THE R-390

Refer to chapter 2 of the R-390A Technical Manual, figures 2-1 and 2-2, pages 2-2 and 2-3, while reading the below description.

1. LINE LEVEL meter (M101)

Function--To indicate the audio output level of the balanced-line.

Operational effect--None.

2. LINE METER switch (S105)

Function--To select 1 of 4 operating ranges for the line meter.

OFF--Disconnects the meter from the balanced-line output circuit.

+10--Adds 10 VU to the VU indication on the line level meter.

0--Indicates a direct reading on the line level meter.

-10--Subtracts 10 VU from the VU indication on the line level meter.

Operational effect--Arranges the R-390's line level meter circuit to indicate a reading corresponding to the range selected.

3. FUNCTION switch

Function--To select 1 of 5 operating functions of the R-390.

OFF--Turns off receiver power.

STANDBY--The receiver is inoperative, and filament voltage is applied to the tubes.

AGC--The receiver is operative, and the gain of the receiver is controlled automatically.

MGC--The receiver is operative, and the gain of the receiver is controlled by the RF gain or some external control.

CAL--The receiver and the internal 100 kHz oscillator are operative for calibration checks.

Operational effect--Arranges internal circuitry of the R-390 to perform the function indicated by the switch.

4. BREAK IN switch (S103)

Function--To permit break-in operation when the proper connections are made on the rear terminal board.

Operational effect--Completes the energizing path for the break-in relay.

5. LINE GAIN control (R104)

Function--To control the level of signal applied to the balanced line audio output terminals.

Operational effect--Adjusts the gain of the line AF amplifier.

6. AUDIO RESPONSE switch (S104)

Function--To allow a selection of either a sharp or wide audio response.

SHARP--Output of the first AF amplifier goes through the 800 Hz band pass filter.

WIDE--Output of the first AF amplifier bypasses the 800 Hz band pass filter.

Operational effect--Arranges the internal circuitry of the R-390 to produce the audio response selected by the switch.

NOTE: The SHARP position of the AUDIO RESPONSE switch is primarily used in CW applications and the WIDE position is used in most other applications.

7. BANDWIDTH KC switch (S501)

Function--To provide the ability to change the bandpass centered on the carrier frequency to the width selected. The six bandwidths are:

.1 kHz	4 kHz
1 kHz	8 kHz
2 kHz	16 kHz

Operational effect--Arranges the internal circuitry of the R-390 to provide the bandpass selected by the switch.

8. BFO PITCH control (L508)

Function--To control the pitch (tone) of the audio output signal when receiving CW and to aid in zero beating (tuning) a signal.

Operational effect--Adjusts the frequency of the tank in the BFO circuit.

9. BFO switch (S101)

Function--To energize/de-energize the BFO.

Operational effect--Applies plate and screen grid voltages to the BFO circuits.

10. PHONES jack (J102)

Function--To allow connection of a headset to the audio output of the R-390.

Operational effect--None.

11. DIODE LOAD jack (J904)

Function--To allow connection of external monitoring equipment to the diode load.

Operational effect--None.

12. LOCAL GAIN control (R105)

Function--To control the audio output to the phones or local speaker.

Operational effect--Adjusts the gain of the local AF amplifier.

13. KILOCYCLE CHANGE control

Function--To provide the capability to tune the various RF circuits to any frequency within a 1 MHz band; also, to change the last 3 digits of the frequency counter.

Operational effect--Arranges the internal circuitry of the R-390 to produce an output signal of the frequency Indicated by the frequency counter.

14. Frequency indicator (counter)

Function--To indicate the frequency that the R-390 is tuned to.

Operational effect--None.

15. ZERO ADJUST control

Function--To provide the capability of calibrating the frequency counter to a known frequency.

Operational effect--Locks the frequency counter so that the KC change control can be tuned to arrange the internal circuitry of the R-390 to correspond with the indication on the frequency counter at a known frequency.

NOTE: The zero adjust control allows 15 kHz of calibration of the frequency counter to the KC change control.

16. RF GAIN control (R103)

Function--To control the output signal level of the first IF amplifier.

Operational effect--Adjusts the cathode bias of the first IF amplifier.

17. MEGACYCLE CHANGE control

Function--To select any frequency band from 1 to 32 MHz in 1 MHz steps; also, to change the first 2 digits of the frequency counter.

Operational effect--Arranges the internal circuitry to produce an output signal at the frequency indicated by the frequency counter.

18. CARRIER LEVEL meter (M102)

Function--To indicate the relative strength of the received RF signal.

Operational effect--None.

19. LIMITER switch and control (R120)

Function--To control static and noise interference.

Operational effect--Adjusts cathode bias of the limiter stage.

20. AGC switch (S107)

Function--To control the rate of change in receiver gain when the signal strength changes. The three positions are: slow, medium, and fast.

Operational effect--Arranges the internal circuitry of the R-390 to apply AGC voltage at the rate of change (attack time) indicated by the switch.

21. ANT TRIM control (C225)

Function--To control peaking of the input RF signal.

Operational effect--Varies the impedance of the input tuned circuit.

22. BALANCED ANTENNA connector (J104)

Function--To provide the capability of connecting the antenna input of the R-390 to a doublet antenna.

Operational effect--None.

23. UNBALANCED ANTENNA connector (J103)

Function--To provide the capability of connecting the antenna input of the R-390 to a whip or long wire antenna.

Operational effect--None.

24. switch (S106)

Function--To control power to the crystal oven.

Operational effect--Applies or secures power to the crystal oven.

C. FUNCTIONAL BLOCK DIAGRAM ANALYSIS OF THE R-390

Turn to chapter 3 of the R-390A Technical Manual and read paragraphs 3.1 through 3.1.5 (page 3-1).

D. SIGNAL FLOW ANALYSIS OF THE R-390A

Turn to chapter 3 of the R-390A Technical Manual and read paragraphs 3.2 through 3.2.19.2, pages 3-1 through 3-14; pay particular attention to the signal flow diagram, figure 5-12, sheets 1 through 2 of 2, pages 5-31/5-32 through 5-33/5-34 and the schematic diagram figure 5-13, sheets 1 through 4 of 4, pages 5-37/5-38 through 5-47/5-48, while studying this material.

E. MECHANICAL TUNING SYSTEM USED IN THE R-390A

Turn to chapter 3 of the R-390A Technical Manual and read paragraphs 3.3 through 3.3.2.3, pages 3-14 through 3-18.

F. MANIPULATING EXTERNAL CONTROLS OF THE R-390A

Turn to chapter 2 of the R-390A Technical Manual and read paragraphs 2.3 through 2.4.2, pages 2-7 through 2-12; pay close attention to table 2-2. Perform step 1 of worksheet WS-2.1.4.

G. PREVENTIVE MAINTENANCE FOR THE R-390A

Turn to chapter 4 of the R-390A Technical Manual and read paragraphs 4.1 through 4.3.5, pages 4-1 through 4-5/4-6; pay close attention to all tables and make notes of the steps in the procedure that give abnormal indications. Perform step 2 of worksheet WS-2.1.4,

H. CORRECTIVE MAINTENANCE FOR THE R-390A

Perform step 3 of worksheet WS-2.1.4.

When you have completed the written portion of this topic, performed all steps of the worksheet, reviewed the material and are confident that you thoroughly understand all aspects of the lesson, proceed to the 'M' Branch classroom to be tested.

After successfully completing the written material, worksheets and test for this topic, contact your learning supervisor and continue with another topic.

CRYPTOLOGIC MAINTENANCE COURSE

CT 'M' BRANCH

INFORMATION SHEET 2.1.4

R-390A/URR RADIO RECEIVER

Now that you have acquired your R-390A receiver and have read thru the technical manual, there are a few additional points that should be mentioned to aid you on working on your receiver.

PHYSICAL LOCATION OF PARTS WITHIN THE RECEIVER

Note from the schematics, block diagrams, etc., that each part in the R-390A is designated by a 3 digit number (C-202, T-501, V-604, etc.). The R-390A is divided into several subchassis. Refer to the location chart on page 7 of this information sheet.

1. The front panel and mainframe of the R-390A is the 100 series sub-chassis. Any part, which has a part number beginning with "1" will be located on this subchassis (TB-102, K-101, etc.).
2. The RE and Tunable IF section is the 200 series subchassis.
3. The 300 series subchassis are not used in this receiver.
4. The 2nd Crystal Oscillator is the 400 series subchassis.
5. The IF section is the 500 series subchassis.
6. The audio section is the 600 series subchassis.
7. The VFO is the 700 series subchassis.
8. The power supply is the 800 subchassis.

MATING OF PLUGS AND JACKS

Locate J-518 on the R-390A. Normally, you would expect P-518 to connect to this jack. What is the number of the plug connected to J-518? _____

1. Note that the last two digits match ... J-518/P-218.
2. The first digit of the jack, "5", tells you that the jack is physically located on the 500 series, IF, subchassis.
3. The first digit of the plug, "2", tells you that the signal on that cable comes from the 200 series, RF, subchassis.

LOCATING A PART ON THE SCHEMATIC DIAGRAM

Open your technical manual to the 4 page schematic diagram, pages 5-35 thru 5-46. Note that there is a "Zoning" list before each page of the schematic. Assume that you are looking for V-206.

1. Look in the zoning charts for a V-206 listing. You will find this on page 5-37. What are the zoning location co-ordinates?

2. Look along the top, bottom and side borders of the schematic diagram.
 - a. The number of the location co-ordinates will locate a vertical column, within which V-206 should be located,
 - b. The letter of the location co-ordinates will locate the tube vertically within the column. This procedure is identical to map reading.

NOTE: The filaments of the tubes are not drawn on the tube portion of the schematic. Check the zoning lists on each page of the schematic to see if V-206 is listed anywhere else. In most vacuum tube circuits, all filaments will be drawn in the power supply section of the schematic for the sake of simplicity.

After you have read the theory of operation, let's take a close look at the signal flow diagram located on pages 5-31 thru 5-34. We will take a signal at the antenna, and follow it completely thru the receiver. The knowledge gained from this brief analysis will aid you greatly in your troubleshooting, because you will know what frequencies to expect at the various stages.

For the purpose of our analysis, we will assume that our receiver is tuned to a signal at 5.237 MHz, using the unbalanced antenna. Open the technical manual to the signal flow diagram and trace along with us.

RF SECTION

1. The 5.237 MHz signal from the antenna will pass thru antenna relay, K-101B and J-105/P-205 to contact #9 of switch S-205.

NOTE: Observe the dashed line connecting S-205, S-204, S-201, S-203, S-207, S-401, and S-402. These switches all change position when the MEGACYCLE CHANGE knob is turned. All switches will automatically be in the proper positions for processing a signal in the 5 MHz band.

2. The RF signal will pass from contact #9 to contact #6 of S-205, be filtered thru the secondary of T-204, and be routed to S-204, contact #5.
3. The signal will pass to contact #8 of S-204, and be applied to the grid (pin 1) of RF amplifier tube V-201.
4. The amplified 5.237 MHz signal at the plate (pin 5) of V-201 is routed thru S-206 (contacts #9 and #6) to filter circuits Z-204-1 and Z-204-2.
5. From Z-204-2, the signal passes thru S-207 (contacts #6 and #9) to the grid (pin 6) of the first mixer, V-202. The frequency of the RF_signal is still 5.237 MHz at this, point.

6. V-202 is a sum mixer. It accepts the RF signal (5.237 MHz) at the grid and a 17 MHz signal from V-207 is applied to the cathode (pin 7). The signals at the plate (pin 1) are the two input signals, plus the sum and difference frequencies (11.763 MHz and 22.237 MHz respectively).
7. Z-213 will be tuned to pass the 22.237 MHz sum frequency, and reject all others. From Z-213, the 22.237 MHz signal passes thru S-208 (front) to the grid (pin 6) of the second mixer, V-203.
8. V-203 is a difference mixer. It accepts the 22.237 MHz signal at the grid, and a signal from the 2nd crystal oscillator at the cathode (pin 7).
9. To find the 2nd crystal oscillator frequency, notice that V-401 is tuned by S-401. Look up S-401 on page 5-41/5-42 of the schematic diagram. Note the numbers at the outside contacts of S-401. These numbers correspond to the MHz band to which the receiver is tuned. We are tuned to a 5.237 MHz signal, so the switch will be making at contact #5 (between #4 and #6). Trace the wire back from contact #5 to Y-406, which is a 12.5 MHz crystal. Therefore, our second crystal oscillator will be operating at 12.5 MHz, or a harmonic of this frequency. Return to the signal flow diagram.
10. If 22.237 MHz are mixed with 12.5 MHz at V-203, the resulting difference frequency will be 9.737 MHz. Note that Z-216 (at the output of V-203) will only tune from 3 to 2 MHz. Therefore, the 12.5 MHz fundamental frequency will not work.
11. If the second harmonic of the crystal is used, V-203 will mix the 22.237 MHz signal with a 25 MHz signal yielding a 2.763 MHz difference signal. Z-216 will pass this signal, and block the sum and the two original signals.
12. The 2.763 MHz output of Z-216 is applied to the grid (pin 6) of the third mixer, V-204. V-204 is a difference mixer, which mixes the incoming RF signal with a signal from the VFO, V-701. The VFO is tuned by the KILOCYCLE CHANGE control. To find the VFO frequency, proceed as follows:
 - a. Note that when the kilocycle portion of the frequency readout dial reads 000, the VFO is set at a frequency of 3.455 MHz.
 - b. As the KILOCYCLE CHANGES control is advanced each kilohertz, the VFO frequency decreases 1 KHz. When the frequency readout dial reads +000, the VFO output is 2.455 MHz.
 - c. Since our receiver is tuned to an RF signal at 5.237 MHz, the VFO output will be 3.218 MHz (3.455 MHz - .237 MHz).
13. The output of the third mixer, V-204 is the difference between our 3.218 MHz VFO signal at the cathode, and the 2.763 MHz RF signal at the grid. The 455 kHz difference frequency is passed by T-208, and the two original frequencies and the sum frequency is blocked from entering the IF circuits.

NOTE: No matter what frequency the receiver is tuned to, the output of the RF circuits must be 455 kHz for the signal to be heard.

Let's tune up a signal at a frequency of 3.854 MHz and see what develops.

What frequencies would you expect to find at the following test points?

Grid (pin 6) of V-202	<u>3.854</u>
Cathode (pin 7) of V-202	<u>17</u>
Grid (pin 6) of V-203	<u>20.854</u>
Cathode (pin 7) of V203	<u>23</u>
Grid (pin 6) of V-204	<u>2.146</u>
Cathode (pin 7) of V-204	<u>2.601</u>
T-20B output	<u>455 kHz</u>

Take a well-earned break before analyzing the IF and audio circuits.

IF/AUDIO SECTION

If you have followed our circuit analysis so far, you should have little difficulty following our signal thru to the end of the receiver. The difficult task of finding oscillator frequencies is over. All of the IF circuits are fix-tuned to 455 kHz. Turn to the second sheet of the signal flow diagram (pages 5-33/5-34).

1. The balanced signal from T-208 arrives at the IF section at J-513 and J-518. Z-501 further filters the 455 kHz signal, preventing the VFO signal from being applied to the IF stages.
2. V-501 amplifies the 455 kHz IF signal and feeds its output to S-502, the bandwidth switch.
3. S-502 and S-503 determine which mechanical filter the 455 kHz signal must pass thru, thus determining the overall bandwidth of the receiver.
4. From S-503, the signal is:
 - a. Amplified by V-502
 - b. Filtered by T-501
 - c. Amplified again by V-503
 - d. Filtered by T-502
5. The output of T-502 splits into two lines
 - a. To V-504 for further amplification, for ultimate use as local audio and line audio.
 - b. To V-509B for generation of AGC. We will consider the AGC circuits first. Then we will return to T-502 and follow the other path.

6. V-509B provides amplification and isolation of the 455 kHz signal. From V-509B, the signal is:
 - a. Routed to J-116 on the back panel of the receiver to provide an IF output for test purposes.
 - b. Applied to V-508.
7. V-508 amplifies the IF signal. Its output is filtered by Z-503 and applied to V-509A.
8. V-509A rectifies the IF signal, and provides a DC output that is proportional to the strength of the incoming RF signal. The output of V-509A is applied to V-506A.
9. V-506A is used to determine the attack time and decay time of the AGC voltage. From V-506A, the AGC voltage is used to:
 - a. Control the gain of several RF and IF stages.
 - b. Drive the carrier, meter to indicate the received signal strength.

NOTE: Attack time is the amount of time lag between the reception of a strong signal, and the time the AGC voltage reduces the gain of the receiver.

Decay time is the time lag between the disappearance of a strong signal, and the time the AGC voltage returns to its nominal value.

10. The second output of T-502 is amplified by V-504 and filtered by T-503.
11. The output of T-503 is rectified by the detector, V-506B. The output of the detector stage is an audio signal, not IF,

NOTE: The detector operates in the same manner as the AGC rectifier. When the BFO is on, it applies a 455 kHz (+ or - 3 kHz) signal into the detector. This signal will mix with the incoming 455 kHz IF signal, producing an audio tone as a difference frequency. This is how a zero beat is produced.
12. The audio output of the detector is routed thru the diode load jumper (on the back panel of the receiver) to V-507. The limiter normally operates as an amplifier, but it can be used to clip off (limit) excessive noise peaks,
13. The audio signal is further amplified by V-601A. The audio then either passes directly to V-601B, or thru an 800 Hz bandpass filter.
14. V-601B amplifies and isolates the audio signal. Its output is applied to the LOCAL GAIN and LINE GAIN controls.

NOTE: The local audio channel and the line audio channel are functionally identical. Only the local channel will be covered.

15. The audio gain is determined by R-105. From R-105, the audio signal is amplified by V-602A and V-603.
16. The output of V-603 is coupled across audio transformer T-601. The audio output is simultaneously available at:
 - a. The headphone jack on the front panel of the receiver.
 - b. Terminals 6 and 8 of TB-102 on the back panel of the receiver.

This has been a superficial analysis of the signal flow diagram. For a more thorough analysis of any circuit, consult the appropriate section of the technical manual. Your instructor will explain any points that are unclear to you.

Armed with this working knowledge of the R-390A, each step of the alignment procedure should be more meaningful to you. As you perform each alignment, refer to the signal flow diagram to see how it affects the overall operation of the receiver. GOOD LUCK!

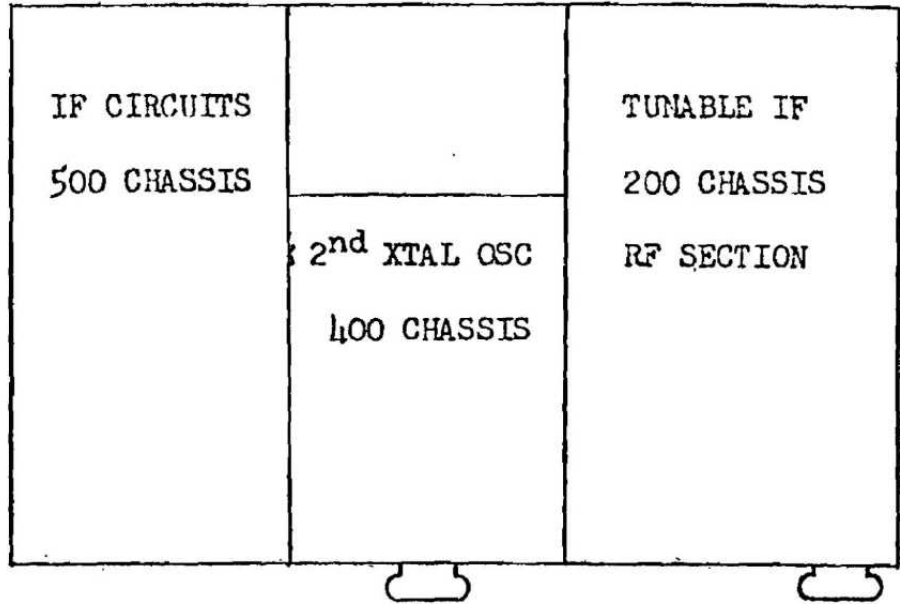

FRONT PANEL AND
MAINFRAME
100 CHASSIS

TOP VIEW

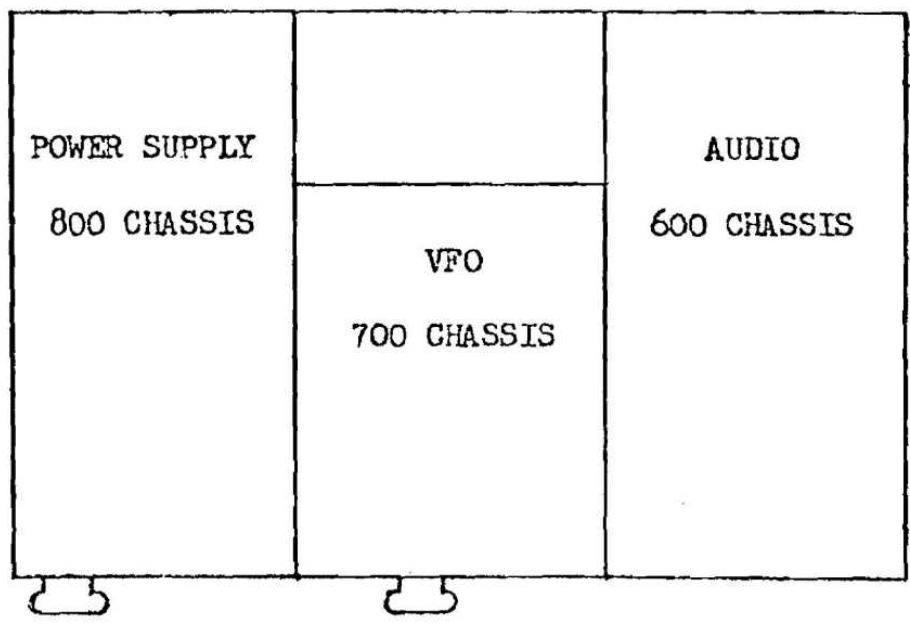

BOTTOM VIEW

NAME _____

CRYPTOLOGIC MAINTENANCE COURSE
CT'M'CLASS 'A' SCHOOL

WORK SHEET 2.1.4B

R-390A/URR RADIO RECEIVER

The R-390A/URR is the standard HF receiver used throughout Security Group and has been proven to be a very reliable and extremely flexible piece of equipment. Since each station has several of these receivers, it would be inconceivable to think that you would not spend several hundred hours in the maintenance of this receiver. Learn it well now and save yourself a lot of time in the field.

BASIC COMMUNICATIONS RECEIVERS

Let us review some terms relating to basic receivers.

SENSITIVITY

The ability of a receiver to amplify and detect a weak RF signal and produce a usable output. Actually, a receiver may appear to have good sensitivity because of an audible output, but the key actually is usable output which means it must be capable of driving external equipment. Normally, the sensitivity of a receiver is measured in the number of microvolts of input signal needed to raise the receiver output level 10 db over the pre-determined minimum noise level.

SELECTIVITY

The ability of a receiver to differentiate between adjacent signals. A receiver with good selectivity may be able to receive a signal even with other signals close by in the frequency spectrum. In other words, it selects one narrow band of frequencies and rejects, or 'blocks out', all unwanted signals.

SUPERHETERODYNE
RECEIVER

This type of receiver converts the incoming RF signal to a lower intermediate frequency (IF), without losing any of the signal's intelligence. Matmen often mistakenly think of a superheterodyne as meaning a high gain receiver. Actually, the receiver does possess high gain (as do all types of good receivers), but the term implies that we have changed the incoming RF signal from, say, 20 MHz to a lower IF of, say, 455 KHz. In other words, we have to 'heterodyne' (mix) the incoming RF signal with local oscillator signals to convert the frequency down to a lower IF. The R-390A/URR uses two stages of mixing for some frequency ranges (double conversion) and three stages of mixing for others (triple conversion).

0.5 - 32 MHz

Basic Block Diagram

Although the R-390A/URR (or any other receiver, for that matter) may seem somewhat 'fancy', it still has the basic sections shown in Figure 1.

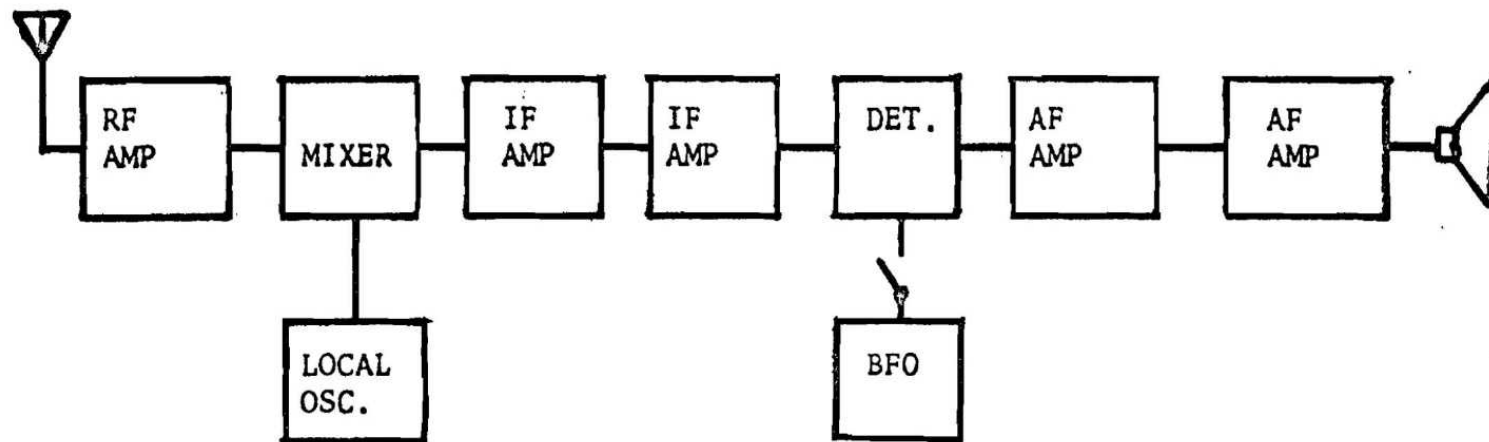

Figure 1

TYPICAL SUPERHETERODYNE RECEIVER

Notice that the incoming RF signal has been taken and reduced to an IF (and eventually audio) by using the mixer's difference frequency. We could have used the sum frequency by employing filters designed for those frequencies, but this is seldom done because of the difficulties in designing stable, tunable circuits at higher frequencies.

One very important point needs to be brought out at this time - the fact that the selectivity of the receiver improves as the signal progresses through the receiver. In other words, the IF section ultimately determines the selectivity of the receiver.

On the receiving antenna, we have signals of just about every frequency present. After the signals pass through the RF section, we may have increased the selectivity to about 100 KHz for any given center frequency. We will continue to narrow this bandpass by using filters, usually located after the mixer stages. Eventually the signal will progress to a final filter in the IF section which may be 8 KHz wide, for example. This would be the final bandwidth, having been reduced from roughly 100 KHz in the RF stages to 8 KHz in the IF.

Uses

As stated previously, a receiver takes an incoming RF signal and converts it to an audio signal. We can use this audio signal for headset listening or for driving external equipment. The 'external' equipment will frequently be a frequency shift converter that, basically, takes the receiver's output and converts it into a stream of DC pulses that would be used to drive (operate) a teletype or similar circuit. A typical system is illustrated in Figure 2.

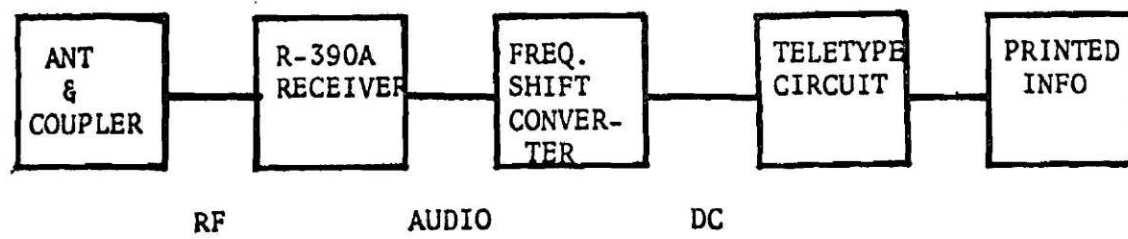

Figure 2

You may note that in place of the teletype (TTY) circuit, we could have substituted an entire computer system. It doesn't matter what the following systems are - without our basic receiver 'picking up' the incoming signals, our TTY and computer would be useless. We might as well pack up and leave without our receivers working!!!

R-390 SHOP PROCEDURE

GENERAL CONDITION CHECK

1. Check all front panel controls for operation and condition.
2. Clean front panel, of all marks and labels, except inventory or modification labels, and clean dial glass.
3. Replace all burnt out lamps (328 lamp).
4. Check for the following field changes:
 - MOD #1: Audio section, V603, pins #2 & #7 shorted together.
 - MOD #2: TB-101 (above the dial glass) pins (#4 & #5) and (#6 & #8) shorted together, respectfully.
 - MOD #3: Aluminum back with Amphenol connector (MS3102R103R-42) and BNC connector, (UG-625 B/U) for both audio and line outputs. Three wire power cable. (Center conductor for Amphenol connector should be on pin #A)
 - MOD #4: Diode load testjack on front panel.
 - MOD #5: Dummy antenna on balanced input and swap leads P 205 & P 206 on N-101 (on the other side of the input jacks).
 - MOD #6: Silicone diode 1N561 in place of 26Z5W in power supply tube sockets V801 & V802. Replace old tube shields (silver spring held) with new type (black pressure held).
5. Turn receiver upside down and clean VFO shaft of all grease and dirt with alcohol and cotton swab.
6. Test all tubes in tube tester.

RT-510 CHECK

Insert a 7 pin adapter into V305 and check AC voltage at pin #3 to ground. If it falls below 6.3 vac. replace 3TF7 or TJ311N01.

5+ VOLTAGE CHECK

1. Connect a PSM-4 to Z-607 (left side of receiver). It should read +150 VDC \pm 3 vdc with function switch in standby.
2. Turn function switch to AGC and B+ voltage should not change by more than \pm 2 volts (if wrong, check V605).

CAM SHAFT ALIGNMENT

Tune receiver to +7000 Mhz. and check to see that the apex of each cam is aligned with its corresponding mark on the receiver chassis.

VFO ALIGNMENT

1. Bottom Adj set KC between 963-972.
2. Set MHz at 00, it should turn a little below 00 MHz

1. Set function switch to AGC.
2. Disconnect P-717 from J-217 and reconnect to frequency counter.
3. Set KHz. knob to 000 and lock down zero adjust knob.

4. Adjust knob for a 3.455 MHz reading on the counter.
5. Loosen zero adjust knob and turn the Khz knob to read +000. The counter should now read 2.455 MHz (± 500 cps). (± 300 cps with VFO out of set)
6. If desired readings are not obtained, first check V701. If that doesn't work then loosen the oldham coupling on the VFO shaft and adjust the shaft until requirements are met. Note: Take care not to turn the shaft past its stop as permanent damage to the VFO will result.
(Remove counter?)

BFO NEUTRALIZATION SECTION MARKED OUT IN NOTES

1. Function switch to CAL.
2. Tune receiver to maximum "carrier level" meter indication at any 100 Khz calibration point.
3. BFO on, BFO pitch to 1, bandwidth to 2.
4. Turn function switch to AGC and connect PSM-4 to diode load (-D.C).
5. Disconnect P-213 from J-513 and ground J-513.
6. Adjust BFO neutralizing capacitor C-525 (on left side of receiver) for minimum reflection on PSM-4 (about -7vdc).

T-208 ALIGNMENT

1. Function switch to MGC, bandwidth to 2.
2. Inject 455 Khz at 30% modulation to test point E-211 at amplitude sufficient to give you between -3vdc and -5vdc at the diode load test jack.
3. Peak T-208.

Z-501 ALIGNMENT

1. Function switch to MGC, bandwidth to 8.
2. Disconnect P-213 from J-513 and P-218 from J518.
3. Connect signal generator to J-518.
4. Inject 455 Khz at 30% modulation at 100 uv.
5. Peak Z-501 (go back and forth between capacitor and inductor for optimum peak indication).

IF GAIN ADJUST

1. Function switch to MGC, Bandwidth to 8.
2. Disconnect P-213 from J-513 and P-218 from J-518.
3. Connect signal generator to J-513.
4. Inject 455 Khz at 30% modulation and 150 uv.
4. Adjust R-519 for -7vdc at the diode load test jack. Anytime work is done on the IF section, this procedure should be redone. (Reconnect P-213 & P-218)

CARRIER METER ADJUST

1. Function switch to AGC, RF gain to zero (fully CCW).
2. Adjust R-523 for 0db on carrier level meter.

CRYSTAL CALIBRATOR ADJUST

1. Tune the receiver to 10 Mhz. (Use 15000 MHz WWV for ? Alignment)
2. Inject 10 Mhz into antenna input (10 Mhz standard from back of frequency counter is convenient for this).
3. BFO to on, BFO pitch centered, function switch to AGC, bandwidth to 8.
4. Lock down zero adjust knob and tune Khz to zero beat with the incoming frequency.
5. Switch function to CAL and adjust "crystal sync. adjust" (C-310 on the rear panel of the receiver) until a null is heard in the speaker. (Null should now be heard in both AGC and CAL).

SECOND CRYSTAL OSCILATOR ADJUST

1. Check to see that the number on the black wheel on the crystal oscillator sub-chassis corresponds to the megahertz dial reading on the front panel.
2. If necessary, loosen the coupling on the oscillator shaft and adjust rear panel "crystal sync, control" so that crystal oscillator is aligned with the corresponding Mhz dial reading.
3. Function switch to CAL, RF gain fully CW.
4. Tune Mhz to 31 and Khz to any 100 Khz calibration point (it should be about -15vdc at the diode load).
5. Peak T-401 and then trimmer #31 for maximum -vdc at diode load. Turn Mhz to 30 and peak trimmer #30 (Etc. on down to 8mhz and trimmer #8).
6. Tune to 7 Mhz and peak T-207.

SECOND VARIABLE IF ALIGNMENT

1. Tune and calibrate receiver to 1.9 Mhz.
2. Function switch to MGC, bandwidth to 8, antenna trim to 0.
3. Inject exactly (count it) 2.1 Mhz at test point E-210 at a level sufficient to give you between -3vdc and -5vdc at the diode load.
4. Peak slugs of Z216-1, Z216-2, and Z216-3 for maximum gain at the diode load.
5. Tune and calibrate receiver to 1.1 Mhz.
6. Inject exactly (count it) 2.9 Mhz at E-210 and adjust trimmers of Z216 in the same order as above.
7. Repeat procedure until no further gain is obtained.

FIRST VARIABLE IF ALIGNMENT

1. Tune receiver to 1.250 Mhz. (Gen 18.250 Mhz)
2. Function switch to MGC, bandwidth to 8, antenna trim to zero.
3. Inject exactly (count it) 18.250 Mhz at test point E-209 at a level sufficient to give you between -3vdc and -5vdc at the diode load.
4. Peak slugs Z213-1, Z233-2 and Z213-3 for maximum gain at the diode load.
5. Tune receiver to 7.250 Mhz. (Gen 24.250)
6. Inject exactly 24.250 Mhz (count it) at E-209.
7. Peak trimmers of Z213 in the same order as above.

- Repeat procedure until no further gain is obtained.

RF ALIGNMENT

- Tune receiver and signal generator to frequencies listed below and adjust appropriate slugs and trimmers accordingly.
- Function switch to MGC, bandwidth to 8 and antenna trimmer to 0.
- Signal is injected into unbalanced antenna input and output is taken from diode load (tweak for maximum -vdc at diode load).
- Again you should go back and forth between slugs and trimmers until no further gain is obtained by PSM-4 at the diode load.

SENSITIVITY CHECKS

- Check for a 10db gain, signal to noise ratio, in the audio output with an audio db meter.
- A sensitivity of 3uv is acceptable, but most receivers will be under 1uv and a sensitivity of .5uv is not uncommon.

<u>RF ALIGNMENT TABLE</u>				<u>SENSE CHECK FREQUENCIES</u>	
1	00.550	L213 L224-1 L224-2			
	00.950		C201-B C230-1 C230-2	00.750	
2	01.100	L215 L225-1 L225-2		01.500	
	01.900		C205-B C233-1 C233-2	03.250	
3	02.200	L217 L226-1 L227-2		04.250	
	03.800		C213-B C236-1 C236-2	06.250	
4	04.400	L219 L227-1 L227-2		08.250	
	07.600		C213-B C239-1 C239-2	10.750	
5	08.800	L221 L228-1 L228-2		13.250	
	15.200		C217-B C242-1 C242-2	15.750	
6	17.600	L223 L229-1 L229-2		18.250	
	30.400		C221-B C245-1 C245-2	20.750	
				23.250	
				25.750	
				28.250	
				30.750	

R-390/URR SYSTEMIZED TROUBLE SHOOTING HINTS

SUBCHASSIS

All injections are at 30% modulation, function switch to MGC, and bandwidth to 8.

- E-209: Tune receiver to 1.250mhz, inject 18.250mhz at 50UV and you should get an audio tone out.
- P-221: Counter at 1V sensitivity should read 17mhz.
- E-210: Tune receiver to 1.9mhz, inject 2.1mhz at 100UV and you should get an audio tone out.
- E-211: Inject 455khz at 10UV and you should get an audio tone out.
- J-217: Tune receiver to +000khz, counter at .1V sensitivity. Counter should read 2.455khz at this point.
- J-415: Tune receiver to 31mhz and counter should read 34mhz. Tune receiver to 30mhz and counter should read 33mhz, continue respectfully.

IF SUBCHASSIS

All injections are at 30% modulation, function switch to MGC, bandwidth to 8.

- J-513: Inject 455khz at 150UV and you should get an audio tone out.
- V502: Inject 455khz at 100UV on pin #1 and you should get an audio tone out.
- V503: Inject 455khz at .001V on pin #1 and you should get an audio tone out.
- V507: Inject 800hz at .15V on pin #8 and you should get an audio tone out.

AF SUBCHASSIS

All injections are at 30% modulation, function switch to MGC, bandwidth to 8.

- V601: Inject 800hz at .04V on pin #2 and you should get an audio tone out.
- V601: Inject 800hz at .6V on pin #7 and you should get line tone out.
- V602: Inject 800hz at .15V on pin #2 and you should get an audio tone out.
- V602: Inject 800hz at .6V on pin #7 and you should get line tone out.
- V603: Inject 800hz at 1.1V on pin #1 and you should get an audio tone out.
- V604: Inject 800hz at 5V on pin #1 and you should get line tone out.

noise check

1. Tune Rec & Gen to selected Freq.
2. Gen set to 1, CW, microvolts 10 10
3. Peak voltmeter with sig. Gen.
4. Microvolts Full CCW
5. Adj. Limiter for noise 10 (selector 0)
6. modulate
7. increase microvolts to 70 VU
8. Go Back to CW - Reading should be less than 3uv.

? Check

1. Tune Rec & Gen to selected Freq.
2. Gen ?, CW, microvolts 10 10
3. Peak voltmeter with sig. Gen.
4. Microvolts Full CCW
5. Adj. ? for ? 10 (? 0)
6. Modulate
7. Increase microvolts 70 VU
8. Go Back to CW - Reading should be less than 3uv

2.1.4 SELF TEST

R-390A/URR General Description and Operation:

1. List the frequency range of the R-390A/URR. **.5 - 32 MHz**
2. List six types of signals received by the R-390A/URR.
3. List the six IF bandwidths of the R-390A/URR and describe the method used to obtain each bandwidth. **.1, 1, 2, 4, 8, 16**
4. List the three audio outputs available from the R-390A/URR. **Line, level, Front panel**
5. List the seven assemblies or subassemblies of the R-390A/URR and the component series number associated with each. **100 Chassis, If, ckts 500 chassis, 2nd cryst. oscill 400 chas, Tunable IF chass. 200, Pwr sup. 800 chass, VFO 700 chas,**
6. List the five positions of the R-390A/URR function switch and describe the function in each position. **Off, standby, AG, MGC, Calibrate (every 100 khz)**
7. Explain the purpose of the breakin switch. **Used in conjunction with xmitter - using same Ant. to send & receive**

Block Diagram Analysis

1. What is the purpose of J-103? **Whips, longwires, random length Ant, single wire Ant. (anything not 125 ohm)**
2. When will K-101 be energized? **Standby position, calibrate & break in**
3. Which front panel control selects antenna transformers T-201 through T-206? **Megacycle knob (change control)**
4. In which frequency bands is V-202 bypassed? **8-32 MHz**
5. Why does the insertion of a ferrite slug into the core of a coil or transformer alter the frequency response of the coil or transformer? **Changes flux density and reactance**
6. What does V-505 do and what is its output? **BFO - beats with IF detector**
7. Which Front Panel Control selects Z-501 and in which position is it bypassed? **IF Bandwidth switch, bypassed in the 2,4,8,16 positions**

Power Supply

1. What is R-619 used for and why is it sometimes shorted out? **Load for VR V605 in standby - taken out in other positions.**
2. What is the purpose of R-124? **Limit current to dial light bulbs**
3. What is the purpose of the breakin circuit? **grounds Ant. see Q7, section I**
4. Why is current regulator RT-510 used in the power supply? **reg. current to V505 (IF subchassis BFO) and V701 (VFO subchassis)**

RF SECTION

1. What is the purpose of I-103 and R-121? **Protects front end (1st RF input) > 80-90 volts**
2. What are the purposes of C-225A and C-225B and when is each used? **Ant. trim**
3. What do S-201 through S-208 have in common? **gang switched on on Mega Cycle change control**

IF SECTION

1. Which two IF bandwidths are provided by Z-501? **.1 & 1**
2. Which three IF bandwidths are provided by or applied through FL-502?
3. Which positions of the function switch allow the proper use of V-505? **MGC, AGC, CAL**
4. For what types of signals would each of the three AGC time constants be used? Why? **To keep noise level from rising between signals (receiver gain constant) slow - max AGC time (i.e. CW) med - i.e. voice, fast i.e. TTY**
5. What is the frequency output of V-504? **(4th IF Amp) 445kHz**

AUDIO SECTION

1. When is FL-601 used? **Bandpass filter for CW**
2. For what purposes are R-105 and R-104 used? **R-105 Line gain & R-104 local gain**
3. What is formed by C-601 and R-602, when and why is it used? **Neg. Feedback path in wide position (degenerative) reduces gain by 5db**
4. What type of circuit is formed by R-111 through R-115? **H-pad -14db prevents mismatch for line audio output**
5. If a 600 ohm load were connected to terminals 10 and 13 of TB-103, what impedance would T-602 see? **600 ohm**
6. What is the purpose of S-104? **Audio response - sharp & wide**
7. Draw three circuits depicting the configuration of the LINE LEVEL meter in each position of S-105.