

INSTRUCTIONS
FOR THE
OPERATION, CARE, AND REPAIR
OF
RADIO PLANTS

(Reprint of Chapter 31 of the Manual of Engineering Instructions)

NAVY DEPARTMENT
BUREAU OF ENGINEERING



WASHINGTON
GOVERNMENT PRINTING OFFICE
1922

NAVY DEPARTMENT,
BUREAU OF ENGINEERING,

24 April, 1922.

The following chapter (Chapter 31, Radio Plants) of the Manual of Engineering Instructions is for official use only. These instructions will become effective upon their receipt, and shall not be made known to persons not connected with the United States Navy. Anything contained in the Manual of Engineering Instructions in conflict with these changes is modified accordingly.

J. K. ROBISON,

Engineer in Chief, United States Navy, Chief of Bureau.

CHAPTER 31.

RADIO PLANTS.

Section I. General instructions—Articles 31-1 to 31-85, inclusive.

Part 1. Organization—Articles 31-1 to 31-26, inclusive.

Part 2. Shore communication stations—Articles 31-27 to 31-68, inclusive.

Part 3. Reports—Articles 31-69 to 31-85, inclusive.

Section II. Spark transmitters—Articles 31-100 to 31-228, inclusive.

Part 1. General—Articles 31-100 to 31-102, inclusive.

(A) The 500-cycle quenched-spark transmitter—Articles 31-103 to 31-149, inclusive.

Part 1. Theory—Articles 31-103 to 31-108, inclusive.

Part 2. Description—Articles 31-112 to 31-125, inclusive.

Part 3. Operation—Articles 31-129 to 31-133, inclusive.

Part 4. Installation—Article 31-136.

Part 5. Care and upkeep—Articles 31-138 to 31-149, inclusive.

(B) Auxiliary spark transmitters—Articles 31-150 to 31-186, inclusive.

Part 1. General—Articles 31-150 to 31-151, inclusive.

Part 2. Theory—Articles 31-152 to 31-155, inclusive.

Part 3. Description—Articles 31-160 to 31-175, inclusive.

Part 4. Operation—Articles 31-177 to 31-181, inclusive.

Part 5. Faults and remedies—Articles 31-185 to 31-186, inclusive.

(C) Motor buzzer transmitters—Articles 31-200 to 31-228, inclusive.

Part 1. General—Articles 31-200 to 31-202, inclusive.

Part 2. Theory—Articles 31-203 to 31-208, inclusive.

Part 3. Description—Articles 31-209 to 31-215, inclusive.

Part 4. Operation—Articles 31-217 to 31-221, inclusive.

Part 5. Faults and remedies—Articles 31-223 to 31-228, inclusive.

Section III. Arc transmitters—Articles 31-250 to 31-297, inclusive.

Part 1. General—Articles 31-250 to 31-253, inclusive.

Part 2. Theory—Articles 31-254 to 31-263, inclusive.

Part 3. Description—Articles 31-264 to 31-273, inclusive.

Part 4. Operation—Articles 31-274 to 31-294, inclusive.

Part 5. Faults and remedies—Articles 31-295 to 31-296, inclusive.

Part 6. Care and upkeep—Article 31-297.

- Section IV. Vacuum tube transmitters—Articles 31-325 to 31-371, inclusive.**
- (A) The vacuum tube used as a transmitter—Articles 31-325 to 31-338, inclusive.
 - Part 1. General—Articles 31-325 to 31-326, inclusive.
 - Part 2. Theory—Articles 31-327 to 31-338, inclusive.
 - (B) Model TB radio telephone equipment—Articles 31-339 to 31-348, inclusive.
 - Part 1. General—Article 31-339.
 - Part 2. Description—Articles 31-340 to 31-343, inclusive.
 - Part 3. Vacuum tubes—Articles 31-344 to 31-347, inclusive.
 - Part 4. Faults and remedies—Article 31-348.
 - (C) The model TC radio equipment—Articles 31-349 to 31-369, inclusive.
 - Part 1. General—Article 31-349.
 - Part 2.—Theory—Articles 31-350 to 31-358, inclusive.
 - Part 3. Description—Articles 31-359 to 31-362, inclusive.
 - Part 4. Operation—Articles 31-363 to 31-364, inclusive.
 - Part 5. Faults and remedies—Articles 31-365 to 31-369, inclusive.
 - (D) Transmitting vacuum tubes—Articles 31-370 to 31-371, inclusive.
- Section V. Aircraft radio equipment—Articles 31-400 to 31-435, inclusive.**
- Part 1. General—Articles 31-400 to 31-406, inclusive.
 - (A) Radio transmitters—Articles 31-407 to 31-417, inclusive.
 - Part 1. Synchronous spark type—Articles 31-407 to 31-408, inclusive.
 - Part 2. Quenched-spark and Chaffee gap types—Articles 31-409 to 31-412, inclusive.
 - Part 3. Vacuum tube type—Articles 31-413 to 31-417, inclusive.
 - (B) Receiving equipment—Articles 31-418 to 31-430, inclusive.
 - Part 1. General—Articles 31-418 to 31-423, inclusive.
 - Part 2. Radio compass—Articles 31-424 to 31-426, inclusive.
 - Part 3. Interphones—Articles 31-427 to 31-430, inclusive.
 - (C) Emergency communication—Articles 31-431 to 31-435, inclusive.
- Section VI. Receiving equipment—Articles 31-450 to 31-503, inclusive.**
- Part 1. General—Articles 31-450 to 31-451, inclusive.
 - (A) Receivers—Articles 31-452 to 31-500, inclusive.
 - Part 1. General—Articles 31-452 to 31-455, inclusive.
 - Part 2. Description—Articles 31-456 to 470, inclusive.
 - Part 3. Operation—Articles 31-471 to 31-490, inclusive.
 - Part 4. Installation—Articles 31-491 to 31-493, inclusive.

Section VI. Receiving equipment—Continued.

Part 5. Care—Article 31-494.

Part 6. Repair—Articles 31-495 to 31-496, inclusive.

Part 7. Faults and remedies—Articles 31-497 to 31-500, inclusive.

(B) Amplifiers—Articles 31-525 to 31-538, inclusive.

Part 1. General—Articles 31-525 to 31-526, inclusive.

Part 2. The audio-frequency amplifier—Articles 31-527 to 31-531, inclusive.

Part 3. The radio-audio-frequency amplifier—Articles 31-532 to 31-538, inclusive.

(C) Vacuum tube detectors—Articles 31-550 to 31-566, inclusive.

Part 1. General—Articles 31-550 to 31-551, inclusive.

Part 2. Description—Articles 31-552 to 31-559, inclusive.

Part 3. Operation—Articles 31-560 to 31-564, inclusive.

Part 4. Faults and remedies—Articles 31-565 to 31-566, inclusive.

(D) Radio-frequency drivers—Articles 31-575 to 31-594, inclusive.

Part 1. General—Articles 31-575 to 31-578, inclusive.

Part 2. Theory—Articles 31-579 to 31-581, inclusive.

Part 3. Description—Articles 31-582 to 31-589, inclusive.

Part 4. Operation—Articles 31-590 to 31-592, inclusive.

Part 5. Faults and remedies—Articles 31-593 to 31-594, inclusive.

(E) Special equipment for increasing selectivity—Articles 31-625 to 31-737, inclusive.

(1) The Acceptor-rejector circuit—Articles 31-625 to 31-663, inclusive.

Part 1. General—Articles 31-625 to 31-626, inclusive.

Part 2. Theory—Articles 31-627 to 31-633, inclusive.

Part 3. Description—Articles 31-634 to 31-650, inclusive.

Part 4. Operation—Articles 31-652 to 31-657, inclusive.

Part 5. Faults and remedies—Articles 31-658 to 31-663, inclusive.

(2) The model RE receiving equipment—Articles 31-675 to 31-698, inclusive.

Part 1. General—Articles 31-675 to 31-677, inclusive.

Part 2. Theory—Articles 31-678 to 31-681, inclusive.

Part 3. Description—Articles 31-682 to 31-691, inclusive.

Section VI. Receiving equipment—Continued.

Part 4. Operation—Articles 31-692 to 31-693, inclusive.

Part 5. Faults and remedies—Articles 31-694 to 31-698, inclusive.

(3) The tuned telephone—Articles 31-725 to 31-737, inclusive.

Part 1. General—Articles 31-725 to 31-726, inclusive.

Part 2. Theory—Article 31-727.

Part 3. Description—Articles 31-728 to 31-732, inclusive.

Part 4. Operation—Articles 31-733 to 31-734, inclusive.

Part 5. Faults and remedies—Articles 31-735 to 31-737, inclusive.

(F) Wavemeters—Articles 31-750 to 31-772, inclusive.

Part 1. General—Articles 31-750 to 31-757, inclusive.

Part 2. Description—Articles 31-759 to 31-762, inclusive.

Part 3. Operation—Articles 31-763 to 31-766, inclusive.

Part 4. Faults and remedies—Articles 31-767 to 31-772, inclusive.

(G) Miscellaneous apparatus—Articles 31-800 to 31-823, inclusive.

Part 1. Telephones—Articles 31-800 to 31-805, inclusive.

Part 2. Crystal detectors—Articles 31-806 to 31-810, inclusive.

Part 3. Vacuum tubes—Articles 31-811 to 31-815, inclusive.

Part 4. Condensers—Articles 31-816 to 31-820, inclusive.

Part 5. Inductances—Articles 31-821 to 31-823, inclusive.

Section VII. Batteries—Articles 31-850 to 31-864, inclusive.

Part 1. General—Article 31-850.

Part 2. The type SE 3535A dry battery—Articles 31-851 to 31-857, inclusive.

Part 3. The Edison "B" battery—Article 31-858.

Part 4. The Edison "A" battery—Articles 31-859 to 31-860, inclusive.

Part 5. Power storage batteries—Articles 31-861 to 31-864, inclusive.

Section VIII. Field sets—Articles 31-875 to 31-896, inclusive.

Part 1. General—Articles 31-875 to 31-877, inclusive.

Part 2. Description—Articles 31-878 to 31-883, inclusive.

Part 3. Operation—Articles 31-884 to 31-889, inclusive.

Part 4. Faults and remedies—Articles 31-890 to 31-896, inclusive.

Section IX. Radio compass equipment—Articles 31-900 to 31-998, inclusive.

Section IX. Radio compass equipment—Continued.

- Part 1. General—Articles 31-900 to 31-905, inclusive.**
Part 2. Theory—Articles 31-906 to 31-913, inclusive.
Part 3. Description—Articles 31-914 to 31-926, inclusive.
Part 4. Installation of radio compass equipment on U. S. naval vessels—Articles 31-927 to 31-928, inclusive.
Part 5. Installation of U. S. naval radio compass shore stations—Articles 31-929 to 31-948, inclusive.
Part 6. Calibration of ship radio compass installations—Articles 31-949 to 31-967, inclusive.
Part 7. Calibration of U. S. naval radio compass shore stations—Articles 31-968 to 31-980, inclusive.
Part 8. Operation—Articles 31-981 to 31-983, inclusive.
Part 9. Faults and remedies—Articles 31-984 to 31-986, inclusive.
Part 10. Testing of circuits and apparatus—Articles 31-987 to 31-998, inclusive.

SECTION I.—GENERAL INSTRUCTIONS.**PART 1.—ORGANIZATION.**

31-1. The Bureau of Engineering is responsible under the law for the maintenance, material supply, and construction of the Coast Signal Service, and funds are annually appropriated to it by Congress for this purpose. Maintenance and operation of Coast Signal Service.

31-2. The Coast Signal Service comprises all mediums of rapid signaling operated by the Navy for the exchange of communications between the Navy Department, the Naval Organization on shore, and the Atlantic, Pacific, and Asiatic Fleets and their auxiliaries, including aircraft. Coast Signal Service.

31-3. The functioning of the Coast Signal Service is effected through the Naval Communication Service. The administration of the Naval Communication Service is under the cognizance of two Bureaus, namely: Administration of Naval Communication Service.

(1) Bureau of Navigation, for personnel, and of the Office of Naval Operations (Director Naval Communications), for operation and traffic.

(2) Bureau of Engineering, for maintenance, material supply, and construction.¹

31-4. The instructions contained in this Manual will cover only maintenance, material supply, and construction under the cognizance of the Bureau of Engineering, which includes the establishment of new communication units and also matters pertaining to investigational, research, design, and development work, patents, requisitions for and manufacture of equipment, inspections, installation and testing, alterations and repairs, the preparation and distribution of technical instructions and data covering the care and operation of radio and sound apparatus and other communication facilities. Scope of Manual.

¹The Bureau of Yards and Docks assists in connection with architecture and construction contracts.

Communication activities.

31-5. The communication activities under the Bureau's cognizance as outlined in the preceding article can be grouped under four general heads, namely:

(1) Radio—Telegraph, telephone, compass, beacon.

(2) Sound.

(3) Homing pigeons.

(4) Land lines—Telegraph, telephone, control, comprising part of shore communication stations.

Communication facilities.

31-6. These communication facilities are depended upon by the Navy, either wholly or in part, in connection with all ship, shore, and aircraft activities.

Mission of Bureau of Engineering.

31-7. The mission of the Bureau of Engineering, with respect to these communication facilities, is:

(1) To prepare, provide, and maintain in condition for continuous efficient service these mediums of communication, so as to meet the requirements of the Fleets, in order that the latter may be *efficiently and economically managed in time of peace, and efficiently maneuvered in time of war.*

(2) To aid in the preservation of life and property at sea and in the air.

(3) To serve other governmental activities and the general public within the limitations imposed by Congress.

Radio Division.

31-8. The administration and functioning of the Naval Communication Service, with respect to maintenance, material supply, and construction, is effected through the Radio Division of the Bureau, the organization of which, and the personnel engaged, under normal conditions, being indicated in Figure 31-1.

Delegation of authority at isolated stations.

31-9. Many of the units comprising the Naval Communication Service are situated in widely separated and isolated localities. Complicated machinery and apparatus are installed at these stations, and they require the attention of skilled mechanics. To meet its responsibilities under these conditions certain material and maintenance activities are delegated to the commanding officers of ships directly, or through the commander in chief, and to commandants of designated navy yards for accomplishment by the radio material officers attached to the yards.

Assignment of radio material officers. Scope of yards.

31-10. Yards at which radio material officers have been assigned and the territory to be covered by these yards for communication maintenance, material supply, and construction activities are indicated below:

Radio material officer, navy yard, Boston: First naval district excepting the navy yard, Portsmouth.

Officer detailed by engineer officer, navy yard, Portsmouth: Within the limits of the Portsmouth yard.

Radio material officer, navy yard, New York: Third naval district and, in addition, the West Indies (assistant to Radio material officer, navy yard, New York; for West Indies, San Juan).

Radio material officer, navy yard, Philadelphia: Fourth naval district.

Radio material officer, navy yard, Norfolk: Fifth naval district, excepting activities along the Severn and Potomac Rivers.

Radio material officer, navy yard, Washington: Activities along the Severn and Potomac Rivers within the fifth naval district.

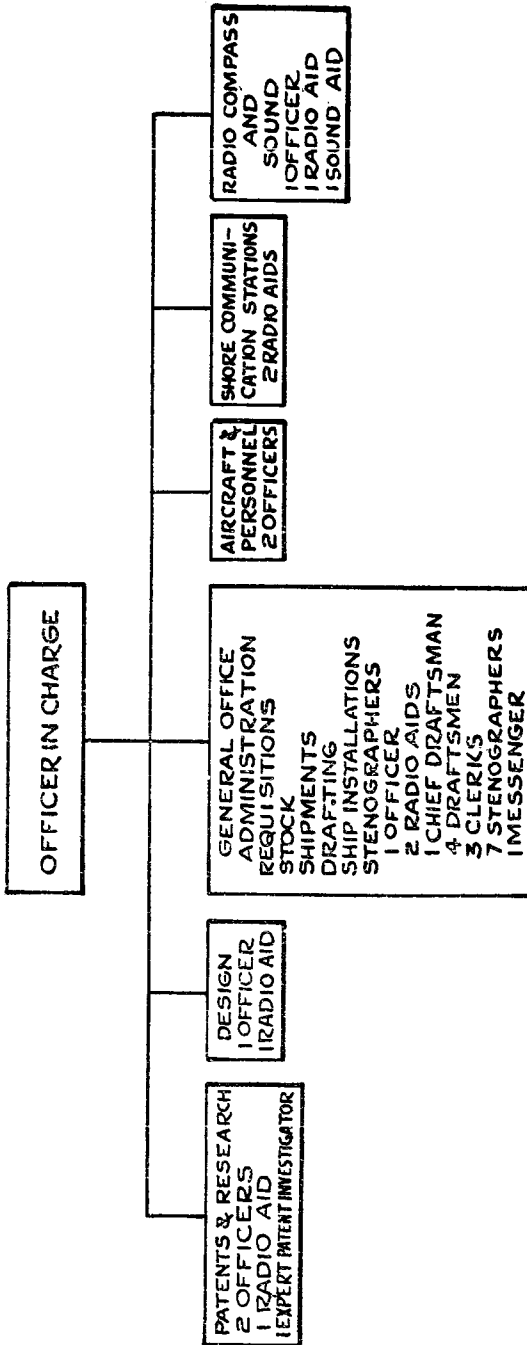

FIG. 31-1.—Organization of Radio Division, Bureau of Engineering.

Radio material officer, navy yard, Charleston: Sixth naval district.

Radio material officer, naval station, Key West: Seventh naval district.

Radio material officer, naval station, New Orleans: Eighth naval district.

Radio material officer, ninth naval district, Great Lakes: Ninth naval district.

Radio material officer, navy yard, Mare Island: Eleventh and twelfth naval districts.

Radio material officer, navy yard, Puget Sound: Thirteenth naval district.

Radio material officer, naval station, Pearl Harbor: Fourteenth naval district.

Radio material officer, fifteenth naval district, Canal Zone: Fifteenth naval district including naval radio stations in the Republic of Panama.

Radio material officer, naval station, Cavite: Sixteenth naval district, including the Peking and Vladivostok stations.

Officer detailed by engineer officer, naval station, Guam: Within the limits of the naval station, Guam.

Officer detailed by engineer officer, naval station, Tutuila: Within the limits of the naval station Tutuila.

Supervisor, Trans-Pacific high-power circuit, navy yard, Mare Island: All high-power stations within the eleventh, twelfth, fourteenth, and sixteenth naval districts comprising this circuit.

Correspondence.

31-11. Correspondence relating to communication maintenance, material supply, and construction will be direct between the Bureau and commandants of maintenance yards except in connection with vessels at sea. In the latter case, correspondence will be direct between the Bureau and the commanders in chief and commanding officers, copies being forwarded to the commandants of the vessels' home yards, and to the responsible unit commanders in the fleets.

Provisions made for operation.

31-12. The Bureau will cause to be maintained, under the industrial department, machinery division of these designated yards and stations, and at other points as may be necessary, adequate facilities for radio material officers to insure the provision, functioning, and coordination of the communication maintenance, material supply, and construction facilities of the Naval Communication Service.

Function of radio material officers.

31-13. The function of radio material officers is to supervise and coordinate all maintenance, material supply, and construction activities in connection with radio, sound, pigeon, and land line facilities relating to ship, shore, and aircraft communication service within the territory assigned by the Bureau to the yards to which they are detailed. It is the Bureau's desire that all personnel regularly engaged in communication maintenance, material supply, and construction work—that is, radio draftsmen, assistant radio inspectors, radio inspectors, radio laboratorians, radio aids, sound aids, pigeon experts, etc.—report directly to the radio material officer in connection with research, design, manufacturing, testing, installations, tuning; in general, all communication main-

tenance, material supply, and construction work for which the yard is made responsible by the Bureau. Manufacturing work carried on in shops by other than communication personnel should be subject to inspection and approval by the radio material officers prior to its acceptance for service.

31-14. The duties and responsibilities of radio material officers ^{Duties of radio} _{material officers.} are:

- (1) (a) To supervise and direct the activities of the radio laboratory and the work of the radio laboratory and field personnel.
- (b) To cooperate with other departments concerning the prosecution of work for, or affecting, the communication service, which may be carried on in other departments or by other than communication technical personnel.
- (2) To maintain the shore communication stations assigned to their yards in condition for continuous efficient operation, making necessary arrangements to utilize the station personnel for this purpose as far as practicable without interfering with their operation and traffic or other duties.
- (3) To perform minor items of repair work, tuning, etc., on vessels in port upon the request of the commanding officers, and major items of alterations, repairs, etc., as directed by the Bureau.
- (4) To supervise the initial installations on vessels and aircraft at builders' yards as directed by the Bureau.
- (5) To perform minor items of repair work, tuning, etc., on aircraft as requested by the commanding officers of air stations or other proper authority, and major items of alterations, repairs, etc., as directed by the Bureau.
- (6) To supervise inspections of shore communication stations over which they have jurisdiction. Radio material officers will make at least every alternate quarterly or periodical inspection except when authorized not to do so by the Bureau of Engineering. Two or more consecutive quarterly or periodical inspections of shore communication stations will not be made by the same yard representative, other than the radio material officer, unless authorized by the Bureau.
- (7) To make recommendations as deemed necessary to maintain these stations in condition for continuous efficient operation.
- (8) To furnish estimates covering expenditures in connection with: (a) The ordinary maintenance, material supply, and construction of shore communication stations, (b) repairs, (c) alterations, (d) the establishment of new stations, which come under the jurisdiction of the industrial department, machinery division.
- (9) To obtain estimates covering expenditures in connection with shore communication stations from other departments having cognizance of work contemplated.
- (10) To maintain close supervision of all expenditures made from funds of the Bureau of Engineering in connection with the Naval Communication Service within their territory to the end that the service may be maintained as economically as possible, consistent with efficiency, and that overexpenditures of allot-

ments do not occur. This will involve cooperating with the Accounting Officer and estimating costs where actual figures are not immediately available.

(11) To cooperate with the Supply Officer as regards the stock of communication material and equipment required and on hand, to the end that sufficient material and equipment may be available to meet the requirements without involving unnecessary purchases or carrying excessive quantities of material and equipment in stock, particularly that which may become obsolete, and preventing deterioration of equipment due to improper care while in storage.

(12) To cooperate closely with the district communication superintendents to insure continuous efficient service and economy of operation in matters other than personnel and traffic.

(13) To confine expenditures in connection with communication matters, over which they have supervision, to the projects authorized annually and to the authorized expenditures under the maintenance allotments as appropriated and authorized.

(14) To cause to be carried on such research, experimental, development, test and other work as may be assigned to their yards from time to time by the Bureau of Engineering.

(15) To direct the maintenance, material supply, and construction of shore communication stations, by correspondence or otherwise, through the officers in charge and the personnel of the stations, furnishing copies of any correspondence to the district communication superintendents having jurisdiction over the stations for operation and traffic.

(16) To prepare correspondence addressed to officers in charge of shore communication stations, and others, regarding other than routine matters for the approval and signature of their immediate superior.

(17) To assign competitive marks to shore communication stations based on the condition of the station as indicated by the service rendered, the economical operation of the station in matters of material and the general condition of all material at the stations as disclosed by the inspections.

(18) To pass on all requisitions and requests for supplies or services at shore communication stations which involve expenditures under the appropriation "Engineering" and to obviate unessential expenditures.

(19) To provide instruction for the personnel of shore communication stations with reference to maintenance, material supply, and construction subjects and also for the communication personnel of ships in port when so directed.

(20) To coordinate all communication maintenance, material supply, and construction work relative to radio, sound, and pigeon facilities utilized by the Naval Communication Service in connection with ship, shore, and aircraft activities, within the territory over which they have supervision.

(21) To arrange for survey of worn out or damaged material and equipment, and for its replacement where necessary and authorized.

(22) To inaugurate methods of procedure for carrying on the detail work as regards maintenance, material supply, and construction matters between shore communication stations and their maintenance yards. This will include routine correspondence and reports, establishment of allowances of expendable supplies for the various stations, shipments and deliveries of material and supplies, inventories, records, etc.

31-15. Activities in connection with communication maintenance, material supply, and construction matters involving action on the part of other Bureaus or agencies of the Department or other governmental agencies, will be handled in conjunction with or through the agencies (or their representatives) having jurisdiction. For example, the Bureau of Construction and Repair for ship structural work, the Bureau of Yards and Docks for public works, the Bureau of Aeronautics for aircraft installations, the Major General Commandant for Marine Corps communication activities, the Bureau of Lighthouses for light vessel installations, district commandants and commanding officers of outlying activities for administrative purposes, etc.

31-16. Communication maintenance, material supply, and construction matters in connection with ships are handled in the following manner: Activities with ships.

(1) Initial installations on new ships are made at the builders' yards under the supervision of radio material officers of designated yards prior to the commissioning of the vessels.

(2) Maintenance and repair work and tuning on ships in port will be accomplished by radio material officers upon request of the commanding officer. New installations, alterations, or extensive repairs will be approved by the Bureau of Engineering prior to undertaking the work.

(3) Work on ships at sea is accomplished by radio officers, or as directed by the commanding officers, the commanders in chief, or unit commanders through the commanding officers.

31-17. Communication maintenance, material supply, and construction matters in connection with communication units on shore are supervised by radio material officers of yards to which the units have been assigned for maintenance. Activities with shore units.

31-18. Communication maintenance, material supply, and construction matters in connection with aircraft activities based on shore are supervised by radio material officers of the yards to which the activities have been assigned by the Bureau. Radio material officers, in such cases, act as the liaison officer under the yard and district commandants and the commanding officer of the air stations. Activities with aircraft shore units.

31-19. Communication maintenance, material supply, and construction matters in connection with aircraft at sea with the fleet are supervised in a manner similar to that followed for ship stations as outlined in article 31-16. Activities with aircraft at sea.

31-20. All tests and experiments in connection with communication apparatus and facilities will be conducted as directed by the Bureau of Engineering, care being exercised always to avoid any interference with operation and traffic matters under the jurisdiction of the Director Naval Communications. Tests.

Activities afloat. 31-21. Communication maintenance and material activities afloat are under the jurisdiction of the commanders in chief, force commanders, squadron commanders, division commanders, and commanding officers in the order named, who, in turn, may delegate the detail work to the officers assigned to radio duties.

Coast Signal Service budget. 31-22. The administration of the maintenance, material supply, and construction work of the Coast Signal Service, as regards expenditures, is effected under a budget system. Recommendations, with estimates, are submitted to the Bureau, periodically, from which the funds required for the annual routine maintenance, material supply, and construction of individual communication units are determined as are those required for other than routine repairs, replacements, alterations, and the establishment of new units.

Program of expenditures. 31-23. The annual program of expenditures, which absolutely limits the expenditures for all communication maintenance, material supply, and construction activities for a fiscal year, is made up as follows:

(a) Recommendations for the annual Alaskan Radio Expedition covering other than routine repairs, replacements, alterations, and the establishment of new shore communication units in Alaska. These recommendations should be in the Bureau not later than December 1 of each year.

(b) Recommendations for the annual routine maintenance, material supply, and construction of individual shore communication units. These recommendations should be submitted by all maintenance yards so as to reach the Bureau not later than March 15 of each year.

(c) Recommendations covering other than routine repairs, replacements, alterations, and the establishment of new shore communication units to be submitted by maintenance yards for all shore communication units (other than the Alaskan stations). These recommendations should be submitted by all maintenance yards so as to reach the Bureau not later than March 15 of each year.

(d) Recommendations by commanding officers of ships covering allowances required for expendable communication supplies for their vessels, and also aircraft which may be attached thereto, and repairs, replacements, alterations, and new installations. These recommendations should be submitted through their immediate superiors for forwarding to the Bureau through the vessels' home yards so as to reach the Bureau not later than March 15 of each year.

(e) Recommendations by commanding officers of naval air stations covering allowances required for expendable communication supplies for aircraft assigned to their stations, and repairs, replacements, alterations and new installations. These recommendations should be submitted through the yard having jurisdiction over communication maintenance, material supply, and construction activities at the air station, so as to reach the Bureau not later than March 15 of each year.

Public works projects. 31-24. Funds for public works projects in connection with shore communication stations are allotted to the Bureau of Yards and Docks for accomplishment under contract or by utilizing labor and material of the stations' maintenance yard.

31-25. Ordinary repair and preservation work at shore communication stations which is under the jurisdiction of the public works department will be accomplished by that department under the stations' maintenance allotment when so directed by the commandant. Repairs.

31-26. It is the Bureau's desire that close cooperation exist between the public works department and the radio material officer in connection with all public works matters pertaining to shore communication stations and particularly as regards the plans for new work and expenditures authorized from this Bureau's appropriation. Co operation
between public
works and radio
material officer.

PART 2.—SHORE COMMUNICATION STATIONS.

31-27. Shore communication stations comprise all communication facilities established on shore and operated by the Naval Communication Service, including light vessels equipped with radio. Shore stations.

31-28. The Bureau of Engineering is responsible for all expenditures pertaining to the grounds, buildings, antenna supports, etc.; the improvements in connection with shore communication stations and the establishment of new units in the chain of stations of the Coast Signal Service. Bureau respon-
sibility.

31-29. Maintenance, material supply, and construction activities on shore are directed by the Bureau through navy yards and naval stations designated as maintenance yards for shore communication activities to which radio material officers have been assigned as assistants to the engineer officers under the commandants. Shore activi-
ties.

31-30. Shore radio and pigeon stations which are situated within maintenance yards will be administrated for maintenance, material supply, and construction matters in the usual manner by radio material officers under the authority of the engineer officer and commandant. Stations with-
in maintenance
yards.

31-31. Shore radio and pigeon stations which are situated within naval air stations will be administrated for maintenance, material supply, and construction matters by their maintenance yards. The radio material officers of the maintenance yards will act as joint liaison officers under the yard and district commandants and the commanding officer of the air station for communication material matters at these stations. Stations with-
in naval air sta-
tions.

31-32. Shore radio and pigeon stations which are situated outside of the limits of the yard to which they have been assigned for maintenance, and which are not within the limits of a naval air station, but are within the limits of a naval district, will be administrated for maintenance, material supply, and construction by their maintenance yards, the radio material officer acting as the radio material representative for the district commandant. Stations out-
side yard, but
within naval dis-
trict.

31-33. Shore radio and pigeon stations which are situated outside the limits of maintenance yards to which they are assigned for maintenance, and which are also outside the limits of air stations, naval districts, and Marine Corps detachment areas, will be administrated for maintenance, material supply, and construction by their maintenance yards, the radio material officers in such Stations out-
side naval dis-
trict.

cases acting as the radio material representative for the commandant or other officer having jurisdiction over the stations in question.

Stations part of Marine Corps detachment. 31-34. Shore radio and pigeon stations, other than strictly portable or field stations, which are established as part of the activities of a Marine Corps detachment, and which are designated as forming part of the chain of coastal communication stations of the Naval Communication Service, are assigned maintenance yards in the usual manner. These stations will be administrated for maintenance, material supply, and construction matters by their maintenance yards in a manner similar to that followed in connection with other stations of the chain of shore communication stations, the radio material officers in such cases acting as the radio material representative for the officer in command of the Marine Corps detachment.

Field sets of Marine Corps. 31-35. The Naval Communication Service is not directly concerned in the portable or strictly field communication stations owned, maintained and operated by the Marine Corps at marine camps or in the field, therefore the Bureau is not responsible for maintenance, material supply, and construction matters pertaining to such stations. Communication material and equipment, including homing pigeons, required by the Marine Corps for use at such field stations, however, will be supplied by the Bureau upon request; payment for such material and equipment, excepting homing pigeons, to be made by transfer of funds. Homing pigeons furnished the Marine Corps for use at field communication stations will remain the property of the Bureau, to be returned when their services are no longer required.

Light vessel radio stations. 31-36. Light vessel stations are assigned maintenance yards in the usual manner and will be administrated for maintenance material supply, and construction matters by their maintenance yards in a manner similar to that followed in connection with other stations of the chain of shore communication stations. Radio material officers will act as the radio material representative for the district commandants and cooperate with the Bureau of Lighthouses district superintendents having jurisdiction over the light vessels.

Repairs by shore station personnel. 31-37. Maintenance, material supply, and construction work at shore communication stations will, when required, be performed by station personnel in accordance with orders issued by the radio material officers and in accordance with the general approval of the commandants or other officers having jurisdiction over the station personnel.

Minor repairs. 31-38. Care will be exercised by radio material officers with a view to having minor items of work within the capacity of the station force performed by the station personnel at all stations, without interfering with their operation and traffic or other duties, rather than incurring the expense of sending working parties from the maintenance yards or awarding contracts to local firms.

Expenses of superintendents. 31-39. The expenses of the offices of district communication superintendents, Pacific coast communication superintendent and Philippine communication superintendent will be paid from the

maintenance allotments of the district center station. The expenses of communication offices at navy yards and stations will be paid from the maintenance allotments of the radio station at such navy yard or station.

31-40. The radio material officer attached to the industrial department, machinery division, of the navy yard, Mare Island, will perform additional duties under the commandant, navy yard, Mare Island, as "supervisor, trans-Pacific high-power circuit." This circuit will be designated for this purpose as consisting of all high-power radio stations (100-kilowatts and above and their controlling stations) in the eleventh, twelfth, fourteenth, and sixteenth naval districts. These additional duties will consist of acting in an advisory capacity to the Bureau of Engineering and the maintenance yards and stations concerned, with a view to coordinating all material matters in connection with the maintenance in condition for continuous efficient operation of, and improvements to, the circuit. The supervisor is not authorized to make expenditures.

31-41. Officers in charge of shore communication stations are responsible for the proper care and preservation of the property comprising their stations as well as the efficient functioning of the equipment. Every endeavor must be made to operate the stations as economically as possible consistent with efficient service, cleanliness and preservation of Government property.

31-42. An inventory will be kept available for inspection of all public property at each shore communication station, radio laboratory, and sound laboratory. The inventory will include descriptive data, means of identification, and cost or valuation, properly arranged by classes as land with roads and walks, fences, antenna supports, buildings and other structures, household and office furniture and furnishings, apparatus, tools, vehicles, etc. This inventory will not include expendable supplies, but a separate record of such supplies showing periodical receipts and expenditures will be kept at the stations for observation and checking.

31-43. The officer in charge of a communication station will be held accountable for all Government property belonging to his station or placed under his care by proper authority. He will receive for all articles invoiced to his station upon receiving and accepting the articles.

31-44. Upon assuming control of a radio station the officer in charge shall immediately report the fact to the maintenance yard in writing. He shall report any discrepancies between the items of public property on hand and those called for by the inventory, and shall call attention to any items in poor condition, the responsibility for which might be a subject of inquiry by an inspecting officer.

31-45. Upon being relieved, the officer in charge shall inspect the station with his successor, giving the latter complete details of the condition of all property at the station, including grounds, antenna supports, buildings and other structures, furniture and furnishings, machinery and equipment; furnish full information concerning the capabilities of the station, the method of obtaining

supplies, etc., and transfer the station to his successor. The latter shall acknowledge the receipt of same, noting any discrepancies over his signature in the inventory records, and assume control of the station.

Transfer of officers.

31-46. Whenever practicable, it is desired that transfer of officers in charge of shore communication stations be made when the radio material officer or his representative can be present, but without involving unnecessary travel, in order that the maintenance yard may have first-hand knowledge of the actual condition of the station at the time of transfer.

Appropriation for wire lines.

31-47. The differentiation between wire communication facilities provided for shore communication stations for payment out of the appropriation "Engineering" and that out of "Pay miscellaneous" will be as follows:

(1) All wire, telegraph, telephone, control signaling or special traffic facilities, provided at shore communication stations for the operation of the stations and all similar facilities provided for the actual handling, relay, receipt or delivery of the radio traffic incident to the operation of the stations, are properly chargeable to the appropriation "Engineering."

(2) All wire communication facilities provided at shore communication stations exclusively for the administration of the stations or the convenience of the personnel, are properly chargeable to the appropriation "Pay miscellaneous."

(3) Wire communication facilities which have been provided to operate the stations or handle the traffic incident to the operation of the stations and which are also authorized used in connection with the administration of the stations, or for the convenience of the personnel, will be charged to the appropriation "Engineering."

Inspection of stations.

31-48. (1) Inspections of shore communication stations as regards maintenance, material supply, and construction will be made by radio material officers having jurisdiction over the stations at quarterly or other authorized periodical intervals, and more frequently when found advisable. This report shall be called the Material Inspection Report of the U. S. Naval Radio Station (name).

(2) Inspections of shore communication stations by radio material officers, so far as they have to do with public works and public utilities, shall not conflict with the annual inspection of public works and public utilities required of public works officers by the Bureau of Yards and Docks.

Inspection reports of shore stations.

31-49. Inspection reports of shore communication stations will be submitted by the commandants to the Bureau in duplicate and copies furnished for information to the district communication superintendents, Atlantic coast communication superintendent, Pacific coast communication superintendent and Philippine communication superintendent having jurisdiction over the stations.

Inspection report of trans-Pacific high-power station.

31-50. Inspection reports of stations of the trans-Pacific high-power circuit will be submitted in quadruplicate and forwarded via the commandant, navy yard, Mare Island, for information of the supervisor, trans-Pacific high-power circuit. One copy of report will be retained in the files of the supervisor, one copy

will be furnished the Pacific coast communication superintendent, for information, and the original report and duplicate copy with endorsements will be forwarded to the Bureau of Engineering.

31-51. Material inspection reports shall cover the following Scope of material inspection.
points:

- (1) Condition of station grounds as regards the efficient functioning of the station.
- (2) Condition of antenna system, including antenna supports and accessories.
- (3) Ground system, in so far as it can be inspected.
- (4) Condition of buildings, tanks, and other structures other than antenna supports.
- (5) Condition of roads and walks.
- (6) Provision for preventing station going out of commission due to carrying away of antenna during storms, collection of sleet, etc., including provisions made for duplicate antenna, or antenna material, hoisting gear, etc.
- (7) Condition of power equipment on the station, including steam boilers, engines, engine-driven generators, power lines and transformers, storage batteries, etc.
- (8) Condition of transmitting equipment and accessories, including motor generators.
- (9) Condition of receiving equipment and accessories, including storage batteries.
- (10) Fire prevention facilities.
- (11) Result of check of station inventory with maintenance yard records.
- (12) Method, care, and preservation of records on station pertaining to station material.
- (13) Condition of plumbing and heating facilities.
- (14) Water supply.
- (15) Sanitation.
- (16) Neatness and cleanliness of property and material comprising the station.
- (17) Expenses in connection with maintenance, material supply, and construction of the station.
- (18) Condition of machine tools and small tools and facilities for making repairs locally.
- (19) General transportation facilities.
- (20) Condition of motor vehicles and other land transportation facilities.
- (21) Condition of motor boats and other water transportation facilities.
- (22) Surveys.
- (23) Maintenance, material supply, and construction, educational facilities and knowledge of station personnel regarding communication, technical matters, and their ability to make repairs.
- (24) Condition of control and communication land lines comprising part of the station.
- (25) Repairs, alterations, or improvements made by station personnel since last inspection.
- (26) Repairs, alterations, or improvements made by yard force since last inspection.

(27) Repairs, alterations, or improvements under way, or authorized to be made by station or yard force.

(28) Familiarity of station personnel with contents of Bureau's monthly radio report.

(29) Discrepancies, if any, in station's authorized transmitting wave lengths.

(30) Defects in material requiring immediate attention and not previously reported, and action taken or recommended.

(31) Defects in material not previously reported and which should be rectified as soon as possible with recommendations where necessary.

(32) Defects in material not previously reported and not urgent which will be given consideration in the annual recommendations.

(33) A list of outstanding recommendations which have been submitted to the Bureau and upon which no action has been taken, or upon which action by the Bureau is not complete, such as new apparatus due, etc.

(34) Condition of recreational facilities, including small arms and ammunition furnished for the protection of the station.

(35) General condition of the station as a whole as regards maintenance, material supply, and construction matters and whether or not the condition of the station appears to be due to the zeal and ability or the neglect and inefficiency of the officer in charge, giving name and rank or rating of the officer in charge.

Items reported on.

31-52. With the following exceptions, the inspection report as submitted need contain only such of the items enumerated in the preceding articles as the inspecting officer may desire to comment on. Reference to items which are found to be entirely satisfactory need not be made in the inspection report. The exceptions are subparagraphs (6), (16), (17), (23), (25), (26), (27), (28), (29), (30), (31), (32), (33), (34), and (35) of the preceding article.

Efficiency of plant to be noted.

31-53. All material inspection reports without exception, however, shall contain a paragraph stating whether the station is considered to be in condition for continuous efficient operation under all circumstances, and if not, what action is contemplated, underway, or recommended to insure its maintenance in condition for continuous efficient operation.

Identity of inspection reports.

31-54. Material inspection reports shall indicate which quarter of the fiscal year, or other authorized period, is covered, and by whom the inspection is made.

Report concerning other departments.

31-55. If material inspection reports contain comments or recommendations pertaining to activities coming under the jurisdiction of departments, other than the industrial department, machinery division, of the maintenance yards, full report of the action taken or contemplated by these departments, with estimates where necessary, shall be obtained prior to forwarding correspondence to the Bureau of Engineering.

Means to insure efficient operation.

31-56. Close cooperation shall be maintained with the district communication superintendents in connection with inspection reports, with a view to insuring the maintenance and operation of the station in an efficient and economical manner, within their allowances, and of insuring that the stations are satisfactory from an operation point of view. Maintenance and new constructional

work which might cause interruption to the Naval Communication Service will not be undertaken at any shore communication station without the approval of the district communication superintendent.

31-57. After an inspection of a shore communication station by a representative of the Department a copy of the report as furnished to the Bureau will be also furnished the radio material officer, via the commandant, for information. **Copy to material officer.**

31-58. Requests or requisitions by officers in charge of shore communication stations for material and supplies will be submitted to or through the radio material officer of their maintenance yards. If the radio material officer having supervision over a shore communication station is assigned to a yard or station other than the maintenance yard of the communication station, officers in charge shall submit requests or requisitions for material and supplies to their maintenance yard via the office of the radio material officer having supervision over the station. **Routing of requests and requisitions.**

31-59. Repairs, other than urgent, and alterations, are to be requested of commandants by radio material officers with recommendations. If necessary, commandants will obtain the approval of Bureau of Engineering before undertaking the work. **Request for repairs.**

31-60. Expenditures in connection with maintenance and upkeep for efficient operation of shore communication stations may be authorized by commandants of maintenance yards, under the stations' maintenance allotments, without previous reference to the Bureau of Engineering, provided the expenditures for any one project do not exceed \$200. If the expenditures for any one project are likely to exceed this figure, the approval of the Bureau of Engineering and the Department will be obtained before undertaking the work. In no case will a shore communication station's maintenance allotment be overdrawn without first obtaining the approval of the Bureau of Engineering. **Authority for expenditures.**

31-61. Correspondence which may be exchanged between officers in charge of shore communication stations and supply officers relating to bids, local contracts, open purchases, shipments, etc., should always be routed via the radio material officer having jurisdiction over matters of material at the station. **Routing bids, contracts, etc.**

31-62. Following is a list of the existing shore communication stations of the Naval Communication Service showing the names of stations, kind of service rendered, naval district in which located, if any, assigned maintenance yard, and the command having jurisdiction over the individual stations: **Shore communication stations.**

Station.	Kind.	District.	Maintenance yard.	Command.
Portsmouth.....	T-R.....	First.....	Portsmouth..	Commandant navy yard, Portsmouth.
Sea Wall.....	T-Tf.....	do.....	Boston.....	Commandant first naval district.
Bar Harbor.....	C.....	do.....	do.....	Do.
Do.....	R.....	do.....	do.....	Do.
Cape Elizabeth.....	C.....	do.....	do.....	Do.
Portland.....	T-R.....	do.....	do.....	Do.
Chelsea.....	T.....	do.....	do.....	Do.
Navy yard.....	R.....	do.....	do.....	Commandant navy yard, Boston.
Gloucester.....	C.....	do.....	do.....	Commandant first naval district.
Deer Island.....	C.....	do.....	do.....	Do.
Fourth Cliff.....	C.....	do.....	do.....	Do.
Radio Laboratory.....	Exp (R).....	do.....	do.....	Commandant navy yard, Boston.
North Truro.....	C (T) (R).....	do.....	do.....	Commandant first naval district.
Chatham.....	C.....	do.....	do.....	Do.
Do.....	T-Tf-R.....	do.....	do.....	Commanding officer naval air station, Chatham.
Surfside.....	C.....	do.....	do.....	Commandant first naval district.
Naval aviation.....	Pgn.....	do.....	do.....	Commanding officer naval air station, Chatham.
Prices Neck.....	C.....	do.....	do.....	Commandant first naval district.
Melville.....	T.....	do.....	do.....	Do.
C. Hbr. Island.....	R.....	do.....	do.....	Do.
Light Vessel No. 3.....	T-R.....	do.....	do.....	Do.
Light Vessel No. 5.....	T-R.....	do.....	do.....	Do.
Light Vessel No. 20.....	T-R.....	do.....	do.....	Do.
Light Vessel No. 41.....	T-R.....	do.....	do.....	Do.
Light Vessel No. 42.....	T-R.....	do.....	do.....	Do.
Light Vessel No. 47.....	T-R.....	do.....	do.....	Do.
Light Vessel No. 73.....	T-R.....	do.....	do.....	Do.
Light Vessel No. 54.....	T-R.....	do.....	do.....	Do.
Light Vessel No. 66.....	T-R.....	do.....	do.....	Do.
Light Vessel No. 74.....	T-R.....	do.....	do.....	Do.
Light Vessel No. 85.....	T-R.....	do.....	do.....	Do.
Light Vessel No. 86.....	T-R.....	do.....	do.....	Do.
Light Vessel No. 90.....	T-R.....	do.....	do.....	Do.
Light Vessel No. 4.....	T-R.....	do.....	do.....	Do.
Navy yard.....	T.....	Third.....	New York.....	Commandant navy yard, New York.
Sandy Hook.....	C.....	do.....	do.....	Commandant third naval district.
Fire Island.....	C (T) (R).....	do.....	do.....	Do.
Amagansett.....	C.....	do.....	do.....	Do.
Do.....	T (R).....	do.....	do.....	Do.
South Ferry Building.....	R.....	do.....	do.....	Do.
Radio Laboratory.....	Exp (R).....	do.....	do.....	Commandant navy yard, New York.
Sayville.....	T.....	do.....	do.....	Commandant third naval district.
Buffalo.....	T-R.....	do.....	do.....	Do.
Light Vessel No. 68.....	T-R.....	do.....	do.....	Do.
Light Vessel No. 87.....	T-R.....	do.....	do.....	Do.
Light Vessel No. 11.....	T-R.....	do.....	do.....	Do.
Light Vessel No. 48.....	T-R.....	do.....	do.....	Do.
Light Vessel No. 23.....	T-R.....	do.....	do.....	Do.
Light Vessel No. 39.....	T-R.....	do.....	do.....	Commandant third naval district.
Light Vessel No. 79.....	T-R.....	Fourth.....	do.....	Commandant fourth naval district.
Light Vessel No. 69.....	T-R.....	do.....	do.....	Do.
Light Vessel No. 44.....	T-R.....	do.....	do.....	Do.
Light Vessel No. 78.....	T-R.....	Third.....	do.....	Commandant third naval district.
Light Vessel No. 16.....	T-R.....	do.....	do.....	Do.
Cayey.....	T.....	do.....	do.....	Governor Virgin Islands.
San Juan.....	R.....	do.....	do.....	Do.
Guantanamo.....	T-Tf.....	do.....	do.....	Commandant naval station, Guantanamo.
Do.....	R.....	do.....	do.....	Do.
Navassa Island.....	T-R.....	do.....	do.....	Do.
Port au Prince.....	T.....	do.....	do.....	Commanding officer Marine detachment.
Do.....	R.....	do.....	do.....	Do.

Station.	Kind.	District.	Maintenance yard.	Command.
St. Thomas.....	T-R.....	New York.....	Governor Virgin Islands.
St. Croix.....	T-R.....	do.....	Do.
San Domingo.....	T-R.....	do.....	Military Governor San Domingo.
Marine land force.....	Pgn.....	do.....	Do.
Navy yard.....	T-R.....	Fourth.....	Philadelphia.....	Commandant navy yard, Philadelphia.
Radio laboratory.....	Exp. (R).....	do.....	Do.
Marine land force.....	Pgn.....	do.....	do.....	Commanding officer Marine detachment.
Cape May.....	T-Tf-R.....	do.....	do.....	Commandant fourth naval district.
Do.....	C.....	do.....	do.....	Do.
Bethany Beech.....	C.....	do.....	do.....	Do.
Cape Henlopen.....	C.....	do.....	do.....	Do.
Lakehurst.....	T-Tf-R.....	do.....	do.....	Commanding officer Naval air station, Lakehurst.
Do.....	C.....	do.....	do.....	Do.
Naval aviation.....	Pgn.....	do.....	do.....	Do.
Mantoloking.....	C.....	do.....	do.....	Commandant fourth naval district.
Annapolis.....	T.....	Naval Academy.....	Superintendent Naval Academy (R. M. O., Navy Yard, Washington).
Naval Academy.....	T-R.....	do.....	Superintendent Naval Academy.
Arlington.....	T.....	Washington.....	Department.
Navy yard.....	T-Tf.....	do.....	Commandant navy yard, Washington.
Navy Department.....	R.....	do.....	Department.
Radio laboratory.....	Exp. (R).....	do.....	Commandant navy yard, Washington.
Anacostia.....	C.....	do.....	Commanding officer naval air station, Anacostia.
Radio laboratory.....	Exp(T)(R).....	do.....	Do.
Naval aviation.....	Pgn-Edu.....	do.....	Do.
Quantico.....	T-R.....	do.....	Commanding officer Marine detachment.
Marine land force.....	Pgn.....	do.....	Do.
Dahlgren.....	Tf.....	Washington.....	Do.
Indian Head.....	T-R.....	do.....	Do.
Naval Proving Grounds.....	Do.
Navy yard.....	T.....	Fifth.....	Norfolk.....	Commandant navy yard, Norfolk.
Hampton Roads.....	R.....	do.....	do.....	Commandant Naval Base, Hampton Roads.
Virginia Beach.....	C.....	do.....	do.....	Commandant fifth naval district.
Do.....	T-TF(R).....	do.....	do.....	Do.
Hog Island.....	C.....	do.....	do.....	Do.
Poyners Hill.....	C.....	do.....	do.....	Do.
Naval Aviation.....	Pgn.....	do.....	do.....	Commandant Naval Base, Hampton Roads.
Radio Laboratory.....	Exp(R).....	do.....	do.....	Commandant navy yard, Norfolk.
Baltimore.....	T-R.....	do.....	do.....	Commandant fifth naval district.
Cape Hatteras.....	T-R.....	do.....	do.....	Do.
Do.....	C.....	do.....	do.....	Do.
Cape Lookout.....	C.....	do.....	do.....	Do.
Morehead City.....	T-R.....	do.....	do.....	Do.
Light Vessel No. 46.....	T-R.....	do.....	do.....	Do.
Light Vessel No. 52.....	T-R.....	do.....	do.....	Do.
Light Vessel No. 72.....	T-R.....	do.....	do.....	Do.
Light Vessel No. 80.....	T-R.....	do.....	do.....	Do.
Light Vessel No. 101.....	T-R.....	do.....	do.....	Do.
Light Vessel No. 91.....	T-R.....	do.....	do.....	Do.
Light Vessel No. 49.....	T-R.....	do.....	do.....	Do.
Navy yard.....	T.....	Sixth.....	Charleston.....	Commandant navy yard, Charleston.
Charleston.....	R.....	do.....	do.....	Commandant sixth naval district.
Radio Laboratory.....	Exp(R).....	do.....	do.....	Commandant navy yard, Charleston.
Folly Island.....	C(T)(R).....	do.....	do.....	Commandant sixth naval district.
North Island.....	C(T)(R).....	do.....	do.....	Do.
Tybee Island.....	C.....	do.....	do.....	Do.
Savannah.....	T-R.....	do.....	do.....	Do.

Station.	Kind.	District.	Maintenance yard.	Command.
Port Royal.....	T-R-Edu.	Sixth.....	Charleston.....	Commanding Officer, Marine detachment.
Light Vessel No. 84.	T-R	..do.....	..do.....	Commandant sixth naval district.
Light Vessel No. 94.	T-R	..do.....	..do.....	Do.
Light Vessel No. 1.	T-R	..do.....	..do.....	Do.
Light Vessel No. 34.	T-R	..do.....	..do.....	Do.
Light Vessel No. 53.	T-R	..do.....	..do.....	Do.
Naval Station.....	T-Tf	Seventh.....	Key West.....	Commandant naval station, Key West.
Key West.....	R	..do.....	..do.....	Do.
Jupiter Inlet.....	C	..do.....	..do.....	Do.
Jupiter.....	T-R	..do.....	..do.....	Do.
St. Augustine.....	T-R	..do.....	..do.....	Do.
Pensacola.....	C	Eighth.....	New Orleans.....	Commanding officer Naval air station, Pensacola.
Do.....	T-Tf-R	..do.....	..do.....	Do.
Naval Aviation.....	Pgn	..do.....	..do.....	Do.
Naval Station.....	T-R	..do.....	..do.....	Commandant naval station New Orleans.
Radio Laboratory.	Exp (R)	..do.....	..do.....	Do.
Pass a Loutré.....	T-R-C	..do.....	..do.....	Commandant eighth Naval district.
Grand Island.....	T-R-C	..do.....	..do.....	Do.
Burrwood.....	T-R	..do.....	..do.....	Do.
Do.....	C	..do.....	..do.....	Do.
Mobile.....	T-R	..do.....	..do.....	Do.
Sabine Pass.....	C	..do.....	..do.....	Do.
Port Arthur.....	T-R	..do.....	..do.....	Do.
Galveston.....	T-R	..do.....	..do.....	Do.
Point Isabel.....	T-R	..do.....	..do.....	Do.
Light Vessel No. 81.	T-R	..do.....	..do.....	Do.
Light Vessel No. 102.	T-R	..do.....	..do.....	Do.
Great Lakes.....	T-Tf	Ninth.....	Commandant ninth naval district.	Commandant ninth naval district.
Do.....	R	..do.....	..do.....	Do.
Air Mail Field.....	L	..do.....	..do.....	Do.
Chicago.....	T-R	..do.....	..do.....	Do.
Radio School.....	Edu	..do.....	..do.....	Commanding officer Great Lakes Radio School.
Naval Training.....	Pgn	..do.....	..do.....	Commandant ninth naval district.
Radio Laboratory.	Exp (R)	..do.....	..do.....	Do.
Milwaukee.....	T-R	..do.....	..do.....	Do.
Manistique.....	C	..do.....	..do.....	Do.
Do.....	T-R	..do.....	..do.....	Do.
Eagle Harbor.....	C	..do.....	..do.....	Do.
Do.....	T-R	..do.....	..do.....	Do.
Duluth.....	T-R	..do.....	..do.....	Do.
White Fish Point.....	T-R-C	..do.....	..do.....	Do.
Grand Marais.....	C	..do.....	..do.....	Do.
Detour Point.....	T-R-C	..do.....	..do.....	Do.
Mackinac Island.....	T-R	..do.....	..do.....	Do.
Alpena.....	T-R	..do.....	..do.....	Do.
Thunder Bay Island.	C	..do.....	..do.....	Do.
Detroit.....	T-R	..do.....	..do.....	Do.
Cleveland.....	T	..do.....	..do.....	Do.
Air Mail Field.....	R	..do.....	..do.....	Do.
Darien.....	T	Fifteenth	Commandant fifteenth naval district.	Commandant fifteenth naval district.
Balboa.....	R	..do.....	..do.....	Do.
Colon.....	T-R	..do.....	..do.....	Do.
Coco Solo.....	T-Tf-R	..do.....	..do.....	Commanding officer Coco Solo Naval Air Station.
Naval Aviation.....	Pgn	..do.....	..do.....	Do.
Cape Mala.....	T-R	..do.....	..do.....	Commandant fifteenth naval district.
Puerto Obaldia.....	T-R	..do.....	..do.....	Do.
La Palma.....	T-R	..do.....	..do.....	Do.
Managua.....	T-R	..do.....	..do.....	Commanding Officer Marine detachment.
Chollas Heights.....	T	Eleventh	Mare Island.....	Commandant eleventh naval district.
Point Loma.....	T-Tf	..do.....	..do.....	Do.
Do.....	C	..do.....	..do.....	Do.
North Island.....	R	..do.....	..do.....	Commanding Officer Naval Air Station North Island.

Station.	Kind.	District.	Maintenance yard.	Command.
Imperial Beach....	C.....	Eleventh.	Mare Island ..	Commandant eleventh naval district.
Naval Aviation...	Pgn.....	.do.....	.do.....	Commanding Officer Naval Air Station North Island.
Inglewood.....	T.....	.do.....	.do.....	Commandant eleventh naval district.
San Pedro.....	R.....	.do.....	.do.....	Commanding Officer Submarine Base San Pedro.
Point Fermin.....	C.....	.do.....	.do.....	Commandant eleventh naval district.
Point Hueneheme...	T-R-C...	.do.....	.do.....	Do.
Point Arguello....	C(T)(R) ..	.do.....	.do.....	Do.
Farallones.....	C(T)(R) ..	.do.....	.do.....	Commandant twelfth naval district.
Point Montara....	C(T)(R) ..	.do.....	.do.....	Do.
Bird Island.....	C(T)(R) ..	.do.....	.do.....	Do.
Point Reyes.....	C(T)(R) ..	.do.....	.do.....	Do.
Beach San Francisco.	T.....	.do.....	.do.....	Do.
South San Francisco.	T-Tf.....	.do.....	.do.....	Do.
Mare Island M. P.	T.....	.do.....	.do.....	Commandant navy yard Mare Island.
Mare Island H. P.	T.....	.do.....	.do.....	Do.
Yerba Buena.....	R.....	.do.....	.do.....	Commandant Naval Training Station, San Francisco.
Radio School.....	Edu.....	.do.....	.do.....	Do.
Radio Laboratory.	Exp (R) ..	.do.....	.do.....	Commandant navy yard Mare Island.
Eureka.....	C.....	.do.....	.do.....	Commandant twelfth naval district.
Do.....	T-R.....	.do.....	.do.....	Do.
Light Vessel No. 70.	T-R.....	.do.....	.do.....	Do.
Light Vessel No. 83.	T-R.....	.do.....	.do.....	Do.
Light Vessel No. 76.	T-R.....	.do.....	.do.....	Do.
Marshfield.....	T-R.....	Thirteenth	Puget Sound ..	Commandant thirteenth naval district.
Empire.....	C.....	.do.....	.do.....	Do.
North Head.....	T-R.....	.do.....	.do.....	Do.
Fort Stevens.....	C.....	.do.....	.do.....	Do.
Ocean Park.....	C.....	.do.....	.do.....	Do.
Astoria.....	T-R.....	.do.....	.do.....	Do.
Seattle.....	T-R.....	.do.....	.do.....	Do.
Keyport.....	T-Tf.....	.do.....	.do.....	Commandant Naval Torpedo Station.
Puget Sound.....	R.....	.do.....	.do.....	Commandant navy yard Puget Sound.
Radio Laboratory.	Exp (R) ..	.do.....	.do.....	Do.
Neau Bay.....	Tf.....	.do.....	.do.....	Commandant thirteenth naval district
Tatoosh.....	C.....	.do.....	.do.....	Do.
Do.....	T-R.....	.do.....	.do.....	Do.
New Dungeness....	C(T)(R) ..	.do.....	.do.....	Do.
Port Angeles.....	C.....	.do.....	.do.....	Do.
Cattle Point.....	C(T)(R) ..	.do.....	.do.....	Do.
Smiths Island.....	C(T)(R) ..	.do.....	.do.....	Do.
Light Vessel No. 67	T-R.....	.do.....	.do.....	Do.
Light Vessel No. 93	T-R.....	.do.....	.do.....	Do.
Light Vessel No. 88	T-R.....	.do.....	.do.....	Do.
Light Vessel No. 92	T-R.....	.do.....	.do.....	Do.
Sitka.....	T-R.....	.do.....	.do.....	Do.
Ketchikan.....	T-R.....	.do.....	.do.....	Do.
Juneau.....	T-R.....	.do.....	.do.....	Do.
Hanscom.....	T.....	.do.....	.do.....	Do.
Eyak.....	R.....	.do.....	.do.....	Do.
Seward.....	T-R.....	.do.....	.do.....	Do.
Soapstone Point...	T-R-C...	.do.....	.do.....	Do.
Hinchenbrook.....	T-R-C...	.do.....	.do.....	Do.
Kodiak.....	T-R.....	.do.....	.do.....	Do.
Dutch Harbor.....	T-R.....	.do.....	.do.....	Do.
Cape Barchef Light	Tf.....	.do.....	.do.....	Superintendent light-houses, Ketchikan.
Scotch Cap Light	Tf.....	.do.....	.do.....	Do.
St. George.....	T-R.....	.do.....	.do.....	Commandant thirteenth naval district.
St. Paul.....	T-R.....	.do.....	.do.....	Do.
Pearl Harbor.....	T.....	Fourteenth	Pearl Harbor..	Commandant Naval Station, Pearl Harbor.

Station.	Kind.	District.	Maintenance yard.	Command.
Air base.....	Tf.....	Fourteenth	Pearl Harbor	Commanding officer Naval Air Base, Pearl Harbor.
Heeia.....	T.....	do.....	do.....	Commandant fourteenth naval district.
Wailupe.....	R.....	do.....	do.....	Do.
Naval aviation.....	Pgn.....	do.....	do.....	Commanding officer Naval Air Base, Pearl Harbor.
Radio Laboratory.	Exp (R).....	do.....	do.....	Commandant Naval Station Pearl Harbor.
Ofu.....	T-R.....		Tutuila.....	Commandant Naval Station, Tutuila.
Tutuila.....	T-R.....		do.....	Do.
Guam.....	T.....		Guam.....	Commandant Naval Station, Guam.
Do.....	C.....		do.....	Do.
Merizo.....	R.....		do.....	Do.
Marine aviation.....	Pgn.....		do.....	Do.
Cavite.....	T.....		Cavite.....	Commandant sixteenth naval district.
Los Banos.....	R.....		do.....	Do.
Olongapo.....	T-R.....		do.....	Commandant Naval Station, Olongapo.
Vladivostok.....	T-R.....		do.....	Commander in chief Pacific Fleet.
Shanghai.....	R.....		do.....	Do.
Peking.....	C.....		do.....	Do.
Do.....	T-R.....		do.....	Do.

Kind of stations.

31-63. The key to the kind of stations is as follows:

B—Radio beacon service (no stations yet in commission).

C—Radio compass receiving stations.

Edu—Communication educational service.

Exp—Radio research and experimental station.

L—Land line communication station only.

Pgn—Homing pigeon station.

R—Receiving and control station (local or remote).

T—Radio telegraph transmitting station.

Tf—Radio telephone station.

Living quarters.

(T) (R)—Stations equipped for transmitting and receiving although nominally not traffic stations.

31-64. Living quarters will be provided for the personnel of shore communication stations which are located outside of a naval or military reservation. Married operators' quarters will be provided where possible to accommodate married personnel of the rating of chief radioman or higher, but the bureau will not authorize the construction of new married operators' quarters to accommodate married personnel holding ratings below chief radioman except in very special cases.

Standard allowance of furnishings.

31-65. Following is the standard allowance of house furnishings at shore communication stations:

OFFICER IN CHARGE QUARTERS.

(Gunner or radioman in charge.)

PAROR OR LIVING ROOM.

1 carpet, rug pattern. 5-frame body. Brussels or Wilton.

2 chairs, upholstered, hardwood frame.

2 armchairs (as above); one rocking-chair can be substituted for one of the armchairs.

- 1 sofa or davenport (as above).
- 1 library table, hardwood.
- 1 set of window shades and fixtures for each window.
- 1 stove, heating, coal, wood, or gas (when required).
- 1 bookcase, small (or bookrack).
- 1 set of scrim curtains with rod and fixtures for each window.

DINING ROOM.

- 1 carpet, rug pattern, 5-frame body, Brussels or Wilton.
- 1 dining table (6-foot extension, 48-inch pedestal), round or square, oak, any finish.
- 1 slideboard, with or without mirror, wood to match above, not less than 54 inches long.
- 6 chairs, wood to match above.
- 1 side table.
- 1 set of window shades and fixtures for each window.
- 8 dinner plates, chinaware.
- 8 coffee cups and saucers, chinaware.
- 8 soup plates, chinaware.
- 8 tumblers, glass.
- 1 water pitcher, glass.
- 2 meat platters, chinaware.
- 2 vegetable dishes, chinaware.
- 2 salt shakers, glass.
- 2 pepper shakers, glass.
- 8 mess bowls, chinaware.
- 1 cream pitcher, chinaware.
- 1 butter dish, chinaware.
- 1 butter knife, plated ware.
- 1 sirup pitcher, glass.
- 1 sugar bowl, chinaware.
- 1 gravy ladle, plated ware.
- 8 table knives, plated ware.
- 8 table forks, plated ware.
- 8 teaspoons, plated ware.
- 8 soup spoons, plated ware.
- 3 tablecloths, cotton, white.
- 12 napkins, cotton.
- 1 carving set.
- 2 dinner platters, chinaware.
- 1 set of scrim curtains with rod and fixtures for each window.

MAIN HALL.

- 1 carpet, 5-frame body, Brussels or Wilton.
- 1 mirror and table.
- 1 set of window shades and fixtures for each window.
- 1 set of scrim curtains with rod and fixtures for each window.

EACH SLEEPING ROOM.

- 1 carpet, rug pattern, 5-frame body, Brussels or Wilton.
- 1 bedstead of enameled iron with one set of springs and one mattress.
- 1 dresser, bureau or chiffonier, with mirror, oak or mahoganyized birch.
- 1 table, small.
- 1 chair, as above, cane or wood seat.
- 1 rocker.
- 1 set of window shades and fixtures for each window.
- 2 pillows.
- 4 sheets, seamless, plain, white, cotton.
- 4 pillowcases, plain, white, cotton.
- 3 blankets, wool, plain.
- 2 bedspreads, cotton.
- 1 set of scrim curtains with rod and fixtures for each window.

UPPER HALL.

- 1 carpet, 5-frame body Brussels or Wilton.
- 1 stair carpet, 5-frame body Brussels or Wilton, including pads.
- 1 set of window shades and fixtures for each window.
- 1 set of scrim curtains with rod and fixtures for each window.

BATH.

- | | |
|--|--|
| 1 rug, small. | 1 set of scrim curtains with rod and fixtures for each window. |
| 1 chair, white enameled. | 1 towel rack. |
| 1 medicine cabinet with mirror. | 1 soap rack. |
| 1 set of window shades and fixtures for each window. | |

KITCHEN, PANTRY, ETC.

- | | |
|--|--|
| 1 range, cooking, coal, wood, or gas. | 1 ladle. |
| 1 refrigerator, top ice, to hold about 100 pounds, white opalite glass lining. | 1 scoop, flour. |
| 1 kitchen table (deal). | 1 cake turner. |
| 2 kitchen chairs. | 1 pudding pan, 2-quart. |
| 2 door foot mats. | 1 dairy pan, 2-quart. |
| 1 egg beater. | 1 can opener. |
| 1 broiler. | 1 lemon reamer. |
| 1 meat fork. | 1 set sad irons or 1 electric iron. |
| 1 meat grinder. | 1 chopping bowl. |
| 1 teakettle. | 1 kitchen cabinet (when no built-in feature provided). |
| 1 teapot. | 1 shovel for coal hod. |
| 1 bread knife. | 1 roast pan, covered. |
| 1 butcher knife. | 1 saucepan, 2-quart. |
| 1 potato masher. | 4 pie pans. |
| 1 bean pot. | 4 bread pans, one-loaf size. |
| 1 dish pan. | 2 bread pans, two-loaf size. |
| 1 saucepan, 3-quart. | 1 mixing bowl, large, earthenware. |
| 1 bread pan. | 4 cake tins. |
| 2 frying pans, one 6-inch, one 9-inch covered garbage can. | 1 muffin tin. |
| 1 wash boiler. | 1 sugar can. |
| 2 washtubs, galvanized iron, when stationary tubs not provided. | 1 tea can. |
| 1 wringer and stand. | 1 double boiler, 2-quart. |
| 1 washboard. | 1 hot-cake griddle. |
| 1 washing machine (one only to be supplied each station and to be for general use at station). | 1 grater. |
| 1 bucket, galvanized iron. | 1 coffee pot or percolator. |
| 1 paring knife. | 1 rolling-pin. |
| 1 waffle iron. | 1 steel. |
| 1 bread box. | 1 freezer, ice-cream, 2-quart. |
| 1 colander. | 1 mixing spoon, cook's, perforated. |
| | 1 mixing spoon, 12 inches long. |
| | 1 flour sifter. |
| | 1 coal hod, galvanized iron, small. |
| | 1 coffee grinder. |

OPERATOR'S BARRACKS.

(Sleeping quarters, per man.)

- 1 bedstead, single, of enameled iron, with one set of springs and one mattress.
- 3 blankets.
- 2 bedspreads, cotton.
- 4 sheets, seamless, plain, white, cotton.
- 1 pillow.
- 2 pillow slips, plain, white, cotton.
- 1 metal locker.
- 1 chair, plain, wood or cane seat.
- 1 set window shades and fittings for each window.
- 1 set of scrim curtains with rod and fixtures for each window.

DINING ROOM.

(Based on complements of approximately 10 men.)

- 1 set window shades and fittings for each window.
- 1 dining table, 8-foot, extension, square, heavy, plain legs, oak.
- 12 chairs, wood, to match above.
- 3 tablecloths, plain, white, cotton.
- 12 mess bowls, chinaware.
- 12 cups and saucers, chinaware.
- 3 vegetable dishes, chinaware or glass.
- 2 cream pitchers, chinaware or glass.
- 2 salt shakers, glass.
- 2 pepper shakers, glass.
- 12 tumblers, glass.
- 2 butter dishes, chinaware or glass.
- 1 carving set.
- 12 table knives, steel, bone handle.
- 12 table forks, steel, bone handle.
- 12 soup spoons, plated ware.
- 12 teaspoons, plated ware.
- 12 dinner plates, chinaware.
- 3 dinner platters, chinaware.
- 2 sirup pitchers, glass.
- 2 sugar bowls, chinaware or glass.
- 2 dinner platters, chinaware.
- 12 soup plates.

KITCHEN.

(Based on complement of approximately 10 men.)

- | | |
|--|--|
| <ul style="list-style-type: none"> 1 kitchen cabinet (when no built-in features provided). 1 covered garbage can. 1 bucket, galvanized iron. 1 paring knife. 1 waffle iron. 1 bread box. 1 colander. 1 ladle. 1 meat fork. 1 bread-mixing pan. 1 tea can. 1 steel. 1 coffee grinder. 1 refrigerator, suitable size. 1 egg beater. 1 broiler. 1 meat grinder. 1 teakettle. 1 bread knife. 1 potato masher. 1 bean pot, 2-quart. 1 dish pan. 2 saucepans, 6-quart. 1 meat saw, 18-inch. 6 bread pans, 2-loaf size. 1 mixing bowl, large. 4 cake tins. 1 cleaver. 1 sugar can. | <ul style="list-style-type: none"> 1 scoop, flour. 1 cake turner. 1 pudding pan, 2-quart. 1 dairy pan, 2-quart. 1 can opener. 1 lemon reamer, glass. 1 set sad irons or 1 electric iron. 1 chopping bowl. 1 shovel for coal hod. 1 double boiler, 2-quart. 3 frying pans, 6-inch, 9-inch and 13-inch. 1 hot-cake griddle. 1 grater. 1 butcher knife, 9-inch. 1 muffin tin. 1 coffeepot. 1 teapot. 2 roast pans, covered. 2 saucepans, 4-quart. 6 pie tins. 1 rolling pin. 1 freezer, ice-cream. 1 mixing spoon, 12 inches long. 1 mixing spoon, cook's, perforated. 1 flour sifter. 1 coal hod, galvanized-iron, large. 1 kitchen table (deal). 1 range, cooking, coal, wood, or gas. 2 kitchen chairs. |
|--|--|

BATH.

- | | |
|---|---|
| <ul style="list-style-type: none"> 1 chair, white enameled. 1 medicine cabinet, with mirror. 1 set of shades and fixtures for each window. | <ul style="list-style-type: none"> 1 set of scrim curtains with rod and fixtures for each window. 1 towel rack. 1 soap rack. |
|---|---|

LIVING ROOM.

(Based on complement of approximately 10 men.)

- 1 library table, plain, suitable size.
- 1 bookcase, sectional.
- 6 chairs, oak or mahoganyed birch, wood or cane seats.
- 4 rockers, oak or mahoganyed birch, wood or cane seats.
- 1 set of window shades and fixtures for each window.
- 1 stove, heating, coal or wood (when required).
- 1 set of scrim curtains with rod and fixtures for each window.

MARRIED OPERATORS' QUARTERS.

LIVING ROOM.

- 1 carpet, rug pattern, 5-frame body Brussels or Wilton.
- 2 chairs, hardwood, saddle seats.
- 1 chair, upholstered, hardwood frame.
- 1 armchair or rocking-chair, as above.
- 1 sofa or davenport, as above.
- 1 library table, hardwood.
- 1 set of window shades and fixtures for each window.
- 1 stove, heater type, coal, wood, or gas (when required).
- 1 bookcase, small (or book rack).
- 1 set of scrim curtains with rod and fixtures for each window.

DINING ROOM.

- 1 carpet, rug pattern, 5-frame body Brussels or Wilton.
- 1 dining table, 6-foot extension, round or square, heavy plain legs, oak, any finish.
- 1 sideboard, without mirror, wood to match above.
- 6 chairs, wood to match above.
- 1 set of window shades and fixtures for each window.
- 3 tablecloths, plain, white, cotton.
- 12 napkins, plain, white, cotton.
- 6 mess bowls, chinaware.
- 6 saucers and cups, chinaware.
- 3 vegetable dishes, chinaware or glass.
- 1 cream pitcher, chinaware or glass.
- 1 salt shaker, glass.
- 1 pepper shaker, glass.
- 6 tumblers, glass.
- 1 cream pitcher, chinaware or glass.
- 6 table knives, plated.
- 6 table forks, plated.
- 6 soup spoons, plated.
- 6 teaspoons, plated.
- 6 dinner plates, chinaware.
- 1 water pitcher, glass.
- 6 soup plates, chinaware.
- 1 gravy ladle, plated ware.
- 1 butter knife, plated ware.
- 2 meat platters, chinaware.
- 1 sirup pitcher, glass.
- 1 sugar bowl, chinaware or glass.
- 1 carving set.
- 1 set of scrim curtains with rod and fixtures for each window.

MAIN HALL.

- | | | | |
|--|--|---|--|
| <ul style="list-style-type: none"> 1 carpet, 5-frame body Brussels or Wilton. 1 hall mirror and table. | <table border="0"> <tr> <td style="border-left: 1px solid black; padding-left: 5px;">1 set window shades and fixtures for each window.</td> </tr> <tr> <td style="border-left: 1px solid black; padding-left: 5px;">1 set of scrim curtains with rod and fixtures for each window.</td> </tr> </table> | 1 set window shades and fixtures for each window. | 1 set of scrim curtains with rod and fixtures for each window. |
| 1 set window shades and fixtures for each window. | | | |
| 1 set of scrim curtains with rod and fixtures for each window. | | | |

EACH SLEEPING ROOM.

1 carpet, rug pattern, 5-frame body.	1 set of window shades and fixtures for each window.
1 bedstead of enameled iron with one set of springs and one mattress.	2 pillows.
1 dresser, bureau, or chiffonier, with mirror, oak or mahogany-birch.	4 sheets, seamless, plain, white, cotton.
1 chair, as above, cane or wood seat.	4 pillowcases, plain, white, cotton.
1 set of scrim curtains with rod and fixtures for each window.	3 blankets, wool, plain.
	2 bedspreads, cotton.

UPPER HALL.

1 carpet, 5-frame body, Brussels or Wilton.	1 set window shades and fixtures for each window.
1 stair carpet, 5-frame body Brussels or Wilton, including pads.	1 set of scrim curtains with rod and fixtures for each window.

KITCHEN.

1 refrigerator, top ice, to hold about 100 pounds.	1 potato masher.
1 egg beater.	1 bean pot.
1 broiler.	1 bread pan.
1 meat fork.	1 sugar can.
1 meat grinder.	1 tea can.
1 teakettle.	1 steel.
1 bread knife.	1 flour sifter.
1 dish pan.	1 coal hod, galvanized-iron, small.
1 saucepan, 3-quart.	1 coffee grinder.
1 saucepan, 2-quart.	1 covered garbage can.
4 bread pans, one-loaf size.	1 wash boiler.
2 bread pans, two-loaf size.	2 washtubs, galvanized iron (when stationary tubs not provided).
1 mixing bowl, large, earthenware.	1 kitchen cabinet (when no built-in features provided).
4 cake ints.	1 wringer and stand.
1 muffin tin.	1 washboard.
1 double boiler, 2-quart.	1 bucket, galvanized iron.
2 frying pans, 6 and 9 inch.	1 shovel for coal hod.
1 hot-cake griddle.	1 paring knife.
1 grater.	1 waffle iron.
1 butcher knife.	1 bread box.
1 coffeepot or percolator.	1 colander.
1 teapot.	1 ladle.
1 roast pan, covered.	1 scoop, flour.
4 pie tins.	1 cake turner.
1 rolling pin.	1 dairy pan, 2-quart.
1 freezer, ice-cream, 2-quart.	1 pudding pan, 2-quart.
1 mixing spoon, cook's, perforated.	1 can opener.
1 mixing spoon, 12 inches long.	1 lemon reamer, glass.
1 range, cooking, coal, wood, or gas.	1 set sad irons or 1 electric iron.
1 kitchen table (deal).	
2 kitchen chairs.	

BATH.

1 set of shades and fixtures for each window.	1 towel rack.
1 chair, white enameled.	1 soap rack.
1 medicine cabinet, with mirror.	1 rug, small.
	1 set of scrim curtains with rod and fixtures for each window.

The limit of expenditures to furnish completely officer in charge quarters is \$1,000 maximum; for married operators' quarters, \$850 maximum; and for operators' barracks, \$100 per man of the authorized complement for complements of 10 men and under

and \$75 per man of the authorized complement for complements in excess of 10 men. Subsequent replacements or repairs are to be absorbed by the station's annual maintenance allotment.

Floor covering. 31-66. Carpets, rugs, linoleum, or matting will be used to cover floors of rooms, at the discretion of the commandants of the maintenance yards, depending on which is considered most suitable with respect to climatic or other conditions prevailing at the stations, costs, etc.

Type of furniture. 31-67. There will be no objections to type of furniture best suited for climatic and other conditions prevailing at the stations being selected at the discretion of the commandants of the stations' maintenance yards, nor to electric ranges or heaters being furnished in place of coal, wood, or gas stoves, provided the initial cost in conjunction with the cost of operation is less for the electrical equipment.

Nettings for beds. 31-68. When considered necessary by the commandants of the maintenance yards for the health and comfort of station personnel, the allowances may be increased to provide for top frames to carry netting and two nettings assigned to the standard allowance for each bed.

PART 3—REPORTS.

Reports. 31-69. The following reports, in addition to those in letter form mentioned in previous articles, will be rendered in connection with communication maintenance, material supply, and construction matters. These do not include such routine reports as the radio material officer may require to be made to his office by officers in charge of shore communications stations.

Annual on April 1. 31-70. On April 1, by commanders in chief to the Secretary of the Navy, with copies to the Director Naval Communications and the Bureau of Engineering, a report outlining the radio, sound, and pigeon communication activities of the fleets, during the preceding fiscal year, and recommendations for the ensuing fiscal year.

Annual on January 1. 31-71. On January 1, by officers in charge of shore communication stations to Bureau of Engineering via their maintenance yard (radio material office), a description of their stations on Form N. Eng. 25A. One copy of this report will be furnished the district communication superintendent and one copy retained for file. Two copies will be forwarded to the radio material officer, who shall retain one copy and forward the other to the Bureau of Engineering.

Annual July 1 and when important changes are made. 31-72. On July 1, and at such times as important changes are made, by commanding officers of vessels, including aircraft in commission, in reserve, and naval auxiliaries, to Bureau of Engineering via official channels of fleet, if attached to fleet, a description of ship's communication installation on Forms N. Eng. 25 B. Report shall be prepared in sextuplicate, one copy furnished to division commander, one to squadron commander, one to commander in chief, one to vessel's home yard, one to the Bureau of Engineering, and one retained in the vessel's files. Vessels not attached to a fleet or to naval districts will forward this report to the Bureau of Engineering, furnishing a copy to the vessel's home yard. (Small ships use Form N. Eng. 269 for radio.)

31-73. On January 1 by commanding officers of district craft, including aircraft, a description of radio installation, on Form N. Eng. 25B. (In case of similar installations on several aircraft at the same station, one report for all aircraft named in the report will suffice.) The number of the copies and official channels for forwarding the report shall be the same as for shore communication stations. (Small ships use Form N. Eng. 260 for radio.) Annual January 1.

31-74. (1) On January 1 by commanding officers of vessels in commission (including vessels in reserve and naval auxiliaries) to Bureau of Engineering annually and at such other times as important changes are made in the sound installation, on Form N. Eng. 71. One copy to be furnished the commander in chief and one copy furnished the vessel's home yard. Annual January 1 or upon extensive alterations.

(2) When there is no sound installation on board, a letter to that effect will be submitted in lieu of Form N. Eng. 71.

31-75. By maintenance yards to Bureau of Engineering at end of each quarter a report of expenditures in connection with shore communication stations during the quarter, on Form N. Eng. 74. Quarterly.

31-76. At end of each quarter, by industrial department, machinery division (radio material officer) of maintenance yards to the Bureau of Engineering, a report reviewing briefly all communication maintenance, material supply, and construction activities coming under their jurisdiction. This report will review the activities within the territory covered as a whole, and will show the personnel employed or engaged in the material branch of the Naval Communication Service at each maintenance yard and outlying points; the nature of the work involved; the conditions in general as regards material within the territory covered; the status of projects underway as regards shore stations, ship stations, sound apparatus, etc., the status of allowances and expenditures; the number and nature of interruptions to the service during the quarter due to troubles with material; meritorious or unsatisfactory service, as regards material, on the part of the personnel concerned; shore communication station marks, etc. This report will be submitted to the Bureau of Engineering in quadruplicate promptly after the end of each quarter.

31-77. Radio material officers quarterly or periodical inspection reports of shore communication stations, to be submitted to the Bureau in duplicate, copies to be furnished to communication supervisory personnel interested.

31-78. At the end of each quarter by supervisor, trans-Pacific high-power circuit to Bureau of Engineering, with copies to commandants of maintenance yards interested, Pacific coast communication superintendent, Philippine communication superintendent, a quarterly review of the trans-Pacific high-power circuit as a whole.

31-79. On the first day of each month by all maintenance yards and the Bureau of Engineering; a report containing all data of interest pertaining to the radio, sound and pigeon activities of the preceding month. Reports of the maintenance yards shall be forwarded to the Bureau of Engineering and to all other navy yards and naval stations, to the commanders in chief, to naval air Monthly.

stations, and to such shore communication stations as may be desirable for instructional purposes. Bureau of Engineering reports will be forwarded to all navy yards, naval stations, air stations, shore communication stations, commanders in chief, squadron and train commanders of the Atlantic, Pacific, and Asiatic Fleets. These reports will comprise a monthly review of all communication maintenance, material supply, and construction activities of the Naval Communication Service.

31-80. By commanding officers of air stations and air detachments, via the yard having supervision over communication maintenance, material supply, and construction matters, to the Bureau of Engineering, a report of aircraft communication material on hand, apparatus installed in planes, and items of interest in regard to radio and pigeon communications.

Special re-
parts, when to
be made. 31-81. By officer in charge shore radio stations to Bureau of Engineering, when important changes are made in apparatus. This report shall be forwarded on Form N. Eng. 25A in the same manner as the annual description of shore radio installations.

31-82. By officer in charge of shore radio stations to their maintenance yard (district radio material officer), whenever a casualty occurs to apparatus which necessitates closing down of the station. Also whenever repairs of apparatus due to casualty are beyond the capacity of the station force.

31-83. After each calibration of ships' radio compasses by commanding officers of vessels in commission, in reserve, and naval auxiliaries to Bureau of Engineering, a radio-compass deviation curve on Form N. Eng. 29. One copy to be furnished the commander in chief and one copy to the vessel's home yard.

31-84. After each calibration of radio compass by officers in charge of shore radio-compass stations to Bureau of Engineering, via maintenance yard, in duplicate, one copy to be retained at maintenance yard, radio-compass deviation curve on Form N. Eng. 29.

Forms. 31-85. The following forms should be obtained from the Bureau of Engineering:

N. Eng. 25A. Description of radio shore station -----	By requisition on Form N. Eng. 52C.
N. Eng. 25B. Description of ship radio installation--	Do.
N. Eng. 29. Radio-compass calibration report-----	Do.
N. Eng. 74. Quarterly report of expenditures -----	Do.
N. Eng. 269. Description of radio installation for small ships-----	Do.
N. Eng. 71. Description of sound apparatus-----	Do.

SEC. II—SPARK TRANSMITTERS.

PART 1—GENERAL.

CLASS OF 31-100. (1) Spark transmitters come under the general class of spark transmitters. damped wave apparatus and are found in three forms in the Naval Service:

- (a) 500-cycle quenched-spark transmitters.
- (b) Auxiliary transmitters.
- (c) Motor buzzer transmitters.

(2) The first two types are generally considered quite similar in operation, the main difference being in the frequency and the type of spark gap employed.

(3) The operation of the third type is similar to that of a buzzer excited circuit and uses a direct current supply. A description of each type is given in the following:

31-101. All spark transmitters supply power to the antenna circuit at intervals, not continuously. The antenna circuit is then permitted to oscillate at its own period, more or less independently of the exciting circuit, depending upon the type of gap employed in the latter circuit. Because the antenna circuit has resistance and, further, because power is not supplied continuously to this circuit, the oscillations set up in the antenna increase in amplitude to a maximum value and then decrease, the rate of decrease or decrement being dependent upon the resistance, and the capacity to inductance ratio of the circuit. The decrement is usually measured by means of a decrementer. Antenna oscillations.

31-102. The 500-cycle transmitter, when adjusted properly, has a spark frequency of 1,000 per second. This spark frequency is dependent upon several factors, viz, the frequency and voltage of the alternating current supply, the size of the capacity to be charged, the length of the gap, and the resistance and reactance of the charging circuit. A train of oscillations is set up in the antenna circuit by each recurring spark. Thus there are 1,000 wave trains per second. The oscillations in the wave train occur at a radio-frequency rate (the frequency of oscillations depends on the constants of the circuit), the number of oscillations in each wave train being determined by the decrement. The duration of each wave train is extremely short. The wave trains occur at intervals of one one-thousandth of a second (one per spark) and are separated by relatively long periods in which no action takes place. The distinctive note of a transmitter, as heard in the telephones, corresponds to the spark frequency. Group frequency.

(A) THE 500-CYCLE QUENCHED-SPARK TRANSMITTER.

PART I.—THEORY.

31-103. The Navy standard 500-cycle quenched-spark transmitter, figure 31-2, consists essentially of three circuits, namely: Circuits.

(1) 500-cycle circuit including the armature of the alternator leads and primary coils of the 500-cycle step-up transformer, secondary coils of the step-up transformer, leads and closed circuit condenser.

(2) Closed, oscillatory circuit including closed circuit condenser, spark gap, closed circuit inductance and leads.

(3) Antenna circuit consisting of antenna (capacity) antenna circuit coupling and loading inductances, ground connection and leads.

31-104. Power for this transmitter is usually supplied by a motor-generator set, the motor of which is adapted to the voltage Power unit.

and type of current available. Frequently the motor is replaced by some other type of prime mover, such as an oil or gasoline engine. The alternator is of the 500-cycle single-phase inductor type. The armature winding consists of two sets of coils. The voltage can be changed by a series or parallel connection of the armature coils and by varying the excitation current of the field coil. In practice, the armature coils are usually connected in series, and the no-load voltage is approximately 275 volts.

The 500-cycle circuit.

31-105. The 500-cycle circuit is usually adjusted to be resonant at a frequency of 440 cycles. The inductance of this circuit includes that of the alternator, leads, reactance, and also a portion is contributed by the transformer as a result of the magnetic leakage. The capacity is primarily supplied by the closed circuit condenser. It has been found that, due to the action of the spark gap

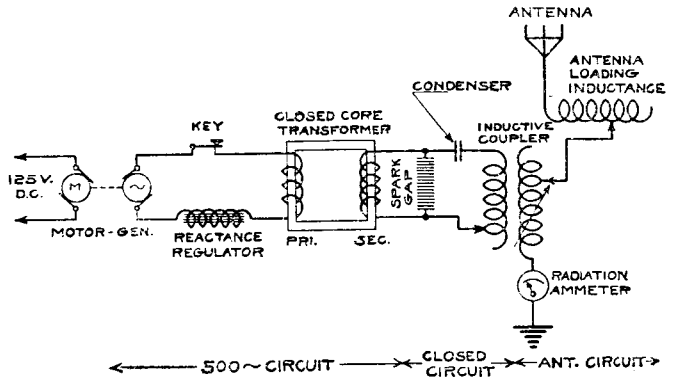

FIG. 31-2.—Circuit diagram of 500-cycle, quenched-spark transmitter.

when it breaks down, the closed circuit condenser acts as if it had a somewhat greater capacity than its actual value. The circuit is adjusted to be resonant to a frequency lower than that impressed upon it, in order that the action of the gap may be uniform, thereby preventing the note of the transmitter from soaring. The condenser is charged alternately to a positive and negative maximum value at a frequency corresponding to that of the alternator, namely, 500 cycles.

The closed circuit.

31-106. (1) The closed circuit, consisting of the closed circuit condenser, quenched-spark gap, primary circuit inductance and leads, oscillates at a radio frequency, the period depending almost entirely on the amount of the inductance and capacity in the circuit. Resistance has very little influence on this period. The theory of the circuit is as follows:

(2) When the spark gap length, resistance and reactance of the charging circuit, etc., have been properly adjusted the condenser is then charged to a voltage sufficiently high to break down the gap at each positive and negative maximum amplitude and one spark per alternation occurs. The spark ionizes the gap, making it a conductor, and oscillations are set up in the closed circuit. These oscillations induce oscillations in the antenna circuit. When the oscillations in the antenna circuit reach their maximum value they react on the oscillations in the closed circuit

through the coupler, decreasing the amplitude of the latter. The resulting current in the closed circuit is insufficient to keep the gap ionized and the gap rapidly becomes deionized and nonconducting. Further oscillation is impossible in the closed circuit. The circuit becomes inactive and the antenna is permitted to oscillate in its own period until all the power transferred to it has been dissipated. This entire operation is repeated with each recurring spark. The momentary current flowing in the closed circuit is very heavy and, if the antenna circuit is not coupled and in tune, there is a serious danger that the spark gap will be burned up, because the power will then be dissipated in a long series of current surges in the closed circuit, instead of being transferred by induction to the antenna circuit.

31-107. (1) The antenna circuit includes the antenna, coupling inductance, loading inductance, ground connection, radiation ammeter, and leads, and acts as a circuit containing inductance and capacity in series. The inductance is that of the coupling and loading coils and the capacity that of the antenna system to ground, the antenna being one plate and the ground the other plate of the condenser. The antenna circuit is usually tuned to resonance with the primary circuit by means of sliding contacts on the inductance coils. The inductance can not be reduced beyond that of the coupling coil which is necessary to transfer the power from the primary circuit to the antenna circuit. In order to obtain still shorter waves a capacity is placed in series with the antenna capacity to reduce the capacity of the circuit. The antenna circuit can then be tuned to resonance with the primary circuit at wave lengths shorter than otherwise possible.

The antenna circuit.

(2) Oscillations are set up in the antenna circuit by induction from the primary circuit, and maximum effect is always produced in the antenna circuit when it is in resonance with the primary circuit.

Antenna oscillations.

(3) When adjustments have been properly made throughout the set, the decrement of the antenna circuit will be lowest for the reason that, after the power has been transferred to the antenna circuit, the gap opens and remains inoperative and the antenna circuit is left to oscillate at its own period and with its own decrement. The period is determined solely by the inductance and capacity of the circuit. The total resistance of the antenna circuit including ohmic, ground, dielectric, and radiation resistance, determines the losses in the circuit. The only useful resistance is that due to radiation and is dependent on the height of antenna and the wave length employed. The radiated power is given by the product of the square of the antenna current and the radiation resistance.

Decrement and radiation.

(4) The total antenna resistance does not affect the period of oscillations but does play an important part in determining the number of oscillations in each wave train; the higher the resistance the fewer will be the number of waves in the wave train and the more highly damped will be the circuit. The oscillations set up in the antenna circuit rise rapidly to a maximum value and then decrease in amplitude with a constant ratio between successive oscillations in the same direction. The more oscillations

Number of oscillations.

there are in a wave train the more nearly does the character of the radiated wave approach that of a continuous wave transmitter. The average decrement is usually 0.05 and, at a distance, the signal tunes in very sharply on the receiving set, thereby causing very little interference.

Table of standard installation. 31-108. Data on the standard types of 500-cycle quenched-spark transmitters now in general use is given in the following table:

Kilo-watt.	Type number.	Wave-length range.	Number of wave lengths.	Type vessel used on.	
½	CM 296.....			Auxiliary for vessels equipped with 2 and 5-kilowatt arc sets.	
	SE 606.....	300-600	2	Shipping Board ships.	
	CE 606-A.....	425-600	2	Do.	
	CE 869-859.....	300-952	6	Submarine power boats, tugs (small), submarines.	
	CR 654-A.....	300-952	6	Do.	
	CE 827.....	300-952	6	Do.	
1	CE 861.....	300-952	6	Mine sweepers.	
	SE 1059.....	300-600	3	Shipping Board.	
	SE 1075.....	300-952	6	Submarine chasers.	
	CE 1221.....	300-952	6	Do.	
2	CM 395.....		6	Airplane bases.	
	CL 344.....	300-1905	8	Naval vessels.	
	CL 342.....	300-1905	8	Do.	
	CL 345.....	300-1905	8	Do.	
	CL 346.....	300-1905	8	Do.	
	CM 305.....	300-1905	8	Do.	
	CR 655.....	300-1905	8	Do.	
	CM 1089.....	300-600	3	Shipping Board.	
	SE 1265.....	300-600	3	Do.	
	5	CM 307.....	600-1905	8	Battleships (secondary), destroyers, tenders, auxiliaries.
		CR 1125.....	300-3020	9	Do.
		CM 853.....	300-3020	11 (any 9)	Do.
SE 1210.....		300-3020	11 (any 9)	Do.	
10	SE 1211.....	300, 3020	11 (any 9)	Do.	
	CL 343.....	750-3020	8	Battleships.	
	CL 304.....	750-3020	8	Do.	

PART 2.—DESCRIPTION.

31-112. The following description of the 5-kilowatt, 500-cycle quenched-spark transmitter, type CR 1125 applies to practically all powers and types of quenched-spark transmitters used by the Navy.

Motor generator. 31-113. The motor generator consists of a 120-volt direct current, 10-horsepower, 4-pole motor with commutating poles, speed 1,666 revolution per minute, direct connected to a 250-volt, 5-kilowatt, 500-cycle, single-phase inductor-type alternator. The armature of the motor and the rotor of the alternator are mounted on the same shaft supported by two end bearings. The complete unit is semienclosed and has overall efficiency of approximately 70 per cent. The bearings are of the ring oil type made of cast iron with babbitt lining of ample surface and held in place with set screws. Hinged covers are fitted over the opening in the top of the bearing housings to keep dust out of the bearings. Sight gauges are provided to indicate the oil level, and the ends of the bearing housings are fitted with oil-tight brass caps. Terminal boxes with an insulated interior fitting provide means of connection to the motor and alternator. The lugs on the ends of leads to the interior of the machine are tapered plugs which terminate in threaded bolt ends, thereby permitting them to be

easily drawn up tight in the taper holes of the terminal blocks. The boxes are tapped for conduit or terminal tubes for the exterior wiring.

31-114. (1) The transformer is of the closed core type and its construction is very simple and access to the different parts easy. In a typical transformer the primary coil consists of 57 turns, two wires in parallel and two layers, diameter of wire 0.1285-inch (No. 8 B. & S.), and is wound directly over one limb of the core and amply insulated from the core by a tube. The trans-
former.
Primary coil.

(2) The secondary winding is in eight sections mounted on a heavy micanite tube which is slipped over the primary coil. Each coil is wound with No. 22 B. & S. gauge D. S. C. wire in 18 layers, 17 turns per layer; total, 306 turns per coil. The layers are insulated with linotape and the wire run through hot "Ohmiac" while being wound, and the same compound used for filling the interstices of the coils. Each coil is taped twice, varnished, and dried. The coils are insulated from each other by a micanite washer 40 mils in thickness. The secondary
winding.

(3) A reactance coil is contained in the transformer case. This coil is used when necessary to bring the 500-cycle circuit to exact resonance with the assigned frequency of 440 for which purpose a step by step adjustment is provided. The reactance
coil.

(4) The safety-spark gap should always be set at three-tenths of an inch. The purpose of this gap is to protect the secondary from being burned out, due to the quenched-spark or rotary gap not functioning properly or when either one has been set too wide. The safety-
spark gap.

31-115. (1) The switchboard contains the switches, circuit breakers, instruments, and rheostats necessary to the proper control of the direct-current and low-voltage alternating current circuits of the transmitting set. The switch-
board.

(2) There are three D. P. S. T. switches mounted on the board. They control (a) the direct-current supply to the motor; (b) the direct-current auxiliary power circuit, and (c) the 500-cycle low-voltage alternating-current circuit.

(3) A double pole circuit breaker is placed in the lower left-hand corner of the lower panel of the switchboard and protects the direct current circuit from a serious overload due to short-circuit or failure of the automatic motor starter to function properly or when the hand starter is operated too rapidly.

(4) A double pole solenoid switch is mounted in the lower right-hand corner of the same panel and is operated by direct current, the circuit for each solenoid being closed or opened by the send-receive switch. One contact controls the 500-cycle alternating-current circuit, while the other is in series with the alternator field coil circuit. Both contacts are closed in the "send" position and open in the "receive" position of the send-receive switch, thus constituting a safety device.

(5) Six instruments are included in the switchboard equipment. These are (a) alternating-current wattmeter; (b) frequency meter; (c) alternating-current ammeter; (d) alternating-current voltmeter; (e) direct-current ammeter; (f) direct-current voltmeter. Enough information can be obtained at all times from

these instruments for the proper and efficient control of the entire transmitting set exclusive of the radio-frequency circuits.

(6) Two rheostats are also supplied, one for varying the field strength of the generator, the other for varying the field strength of the motor. The first controls the voltage of the generator within rather wide limits for any given speed of the motor generator set, while the second controls the speed of the motor generator set, and hence the frequency of the alternator.

(7) A relay key, which breaks the alternating-current circuit and is operated by a hand-key on the direct-current supply, is frequently mounted on the switchboard below the A. C. D. P. S. T. switch.

Transfer switch. 31-116. A 5-pole double-throw transfer switch is supplied for connecting the direct current supply to either the automatic starter or hand starter. Normally, the automatic starter is used, the hand starter being employed only in cases of emergency.

Spark gaps. 31-117. Two types of spark gaps are supplied with this set. They are the quenched-spark gap unit and the rotary gap unit, the first being generally used.

The quenched gap. (1) The quenched gap consists of 15 gaps in series. The number of gaps employed can be regulated by means of sliding clips. Defective gaps may be cut out of circuit by short-circuiting clips. Each gap is a complete unit and is made airtight by means of suitable gaskets. There are two sparking surfaces in each unit, which are plane and parallel to each other, the proper separation of 10 mils between the surfaces being effected by the thickness of the gasket. Individual gaps are clamped together to make the assembly, and the whole assembly kept cool by natural radiation from fins attached to the sparking surfaces. In some installations forced cooling is employed, in which case a blower is used.

The rotary gap. (2) The rotary gap is of the nonsynchronous type and consists of two parts (*a*) stator, and (*b*) rotor. A pure musical note, frequency 1,000, can be obtained. In addition, 500, 250, or 125 sparks per second can be obtained by decreasing the generator voltage. It is possible to operate at high power when the 1,000-spark per second note is employed, the break frequency in this case being approximately 5,000 per second. This is accomplished by the vernier arrangement of the electrodes, there being more revolving than stationary electrodes. Because of this unequal number of electrodes, there are a number of sparks around the circumference of the gap, while one of the revolving electrodes is passing from one stationary electrode to the next. There are 14 revolving and 12 stationary electrodes.

Condensers. 31-118. The condensers are of the mica dielectric type. Each unit has a capacity of 0.004 μf . There are eight condensers in each set, which are mounted in a condenser rack, and the connections are made in such a way that for wave lengths above 538 meters all eight condensers are connected in parallel, capacity 0.032 μf . For all wave lengths below 600 meters they are divided in two banks in series, each bank containing four condensers in parallel, the total capacity being 0.008 μf . Full power can only be realized on those wave lengths employing all the condensers in parallel.

31-119. (1) The inductive coupler consists of two coils insulated from each other, one being fixed and the other movable. The amount of separation between the coils is controlled by a lever on the side of the coupler. Both coils are made of copper ribbon wound in spiral form. The fixed coil is the closed oscillatory circuit inductance and is in series with the spark gap and transmitting condenser. Contacts are provided on the front panel of the coupler for making the necessary connections to the condenser bank and to the primary inductance coil of the coupler. Taps are brought from the proper points on this coil to the contacts and a hand-operated lever is provided for making the various necessary connections. Inductive coupler.

(2) The inductive coupler also functions as a wave changer in that the wave length can be changed to previously determined values by means of the wave-changer switch. The shaft of this wave-changer switch carries on its far end a switch bar which makes contact on studs on the rear panel. The movable coil is included in the antenna circuit and is similar to the closed circuit inductance coil in that taps are brought from previously determined points on it to the proper studs on the rear panel. In this manner the wave changer switch cuts in or out approximately the proper amount of inductance for both the closed and antenna circuits.

31-120. No variometer is supplied with this set. Some types of sets are equipped with a variometer which is connected in series with the wave changer closed circuit inductance and consists of a few turns of spirally wound copper ribbon with a continuously variable or sliding contact finger mounted on the front panel. The purpose of the variometer is to permit a very close adjustment to the wave length of the closed circuit, thereby obviating the necessity of adjusting the clips on the closed circuit inductance with great precision. Variometer.

31-121. The antenna loading inductance consists of eight spirally wound copper-ribbon coils, quite similar in construction to the coils used in the inductive coupler. These coils are mounted on three insulating rods by clamps attached to their rims, and are connected in series by a strip passing from one coil to the next. The amount of inductance used in each coil can be varied continuously by turning a knob located near the rim of the coil. This knob is connected to a mechanism which revolves a clip that slides along the copper ribbon. A terminal is supplied on each coil for making connection to the proper contact stud on the rear panel of the inductive coupler and wave changer. There are as many coils in the antenna loading inductance unit as there are outgoing terminals on the wave changer switch. Antenna loading inductance.

31-122. (1) The send-receive switch is located in a position convenient to the operator's hand and is used primarily for transferring the antenna from the transmitter set to the receiving set, and at the same time opens or closes the proper circuits. Send-receive switch.

(2) In the "send" position (horizontal), the send-receive switch performs the following operations:

- (a) Closes a break in field circuit of alternator.

(b) Closes circuit that operates the solenoid of clapper switch on switchboard (which is a double-pole switch and controls alternator field and armature).

(c) Closes circuit that operates detector protective relay.

(d) Closes one spare set of contacts.

(e) Grounds the terminal that connects to receiver.

(f) Connects antenna to loading coil of transmitter.

(3) In the "receive" position (vertical), the switch does the following:

(g) Opens contacts closed by operations (a), (b), (c), (d).

(h) Connects receiver lead to the antenna. The connection (e) should remain closed until the antenna is grounded just before the switch reaches the final receiving position; contact (b) opens before (a) so that spark on breaking the field will occur at the clapper switch and not at the antenna switch unless the clapper switch should fail to open.

Lightning switch. 31-123. A switch is mounted next to the antenna lead-in and is used for connecting the antenna to the "send-receive" switch, or directly to ground for the protection of all the apparatus.

Protective devices. 31-124. (1) Protective devices are installed with the transmitter set to protect the following apparatus:

(a) Alternator armature.

(b) Direct current motor armature.

(c) Alternator field and direct current motor field.

(d) Primary of transformer.

(e) All auxiliary motors.

(2) The protective device consists of two mica dielectric condensers of approximately $0.05 \mu\text{f}$ each, connected in series across the line to be protected, with the common connecting wire connected to the metal protective casing, which in turn is grounded.

Antenna ammeter. 31-125. A antenna ammeter is connected in series with the antenna circuit next to the ground connection to indicate the current flowing in the antenna circuit.

PART 3.—OPERATION.

Tuning the 500-cycle circuit. 31-129. The best performance and greatest efficiency of the transmitter is obtained when the 500-cycle circuit is resonant to the proper frequency. This frequency is 440 cycles for all Navy standard 500-cycle quenched-spark transmitters. It should, therefore, be ascertained whether or not the 500-cycle circuit is resonant to this frequency; and if not, it should be adjusted to 440 cycles. It was stated in Article 31-105 that, due to the short-circuiting action of the spark gap, the condenser assumes a fictitious value somewhat greater than the actual. Clearness of note, maximum radiation, and proper quenching are all closely related to the proper tuning of the 500-cycle circuit.

Method of finding resonant frequency of 500-cycle circuit. 31-130. (1) (a) Open quenched-spark gap completely so that no sparking will occur.

(b) Start motor generator set.

(c) Reduce frequency to lowest value possible.

(d) Open alternator field circuit. (This is very important.)

(e) Close transmitting key.

(f) Vary motor speed (alternator frequency) slowly from lowest to highest and carefully watch alternating current ammeter for maximum reading.

(g) Note frequency at which maximum reading of alternating current ammeter occurs. This is the resonant frequency.

(2) If this frequency is above or below 440 cycles, the circuit should be adjusted to be resonant to approximately 440 cycles. This is done by changing the inductance of the circuit, more inductance being added if the resonant frequency is above 440 cycles and some of the inductance removed if below this frequency. The device used for this purpose is called the *reactance regulator*. It is situated in the transformer casing, and is furnished with taps so that the amount of reactance may be varied by steps.

(3) This operation should be performed for each combination of motor generator and transformer when the set is installed. After this operation has been completed the transmitting set is ready for wave-length tuning.

31-131. Most transmitters are able to transmit on several different wave lengths, the 5-kilowatt set just described having eight wave lengths. The procedure for tuning is as follows:

Tuning the transmitter to specified wave lengths.

(1) Loosen coupling between primary and secondary coils of inductive coupler.

(2) Start motor generator set.

(3) Throw send-receive switch to send position and disconnect antenna by throwing lightning switch to ground.

(4) Reduce number of gaps cut in to two or three.

(5) Reduce alternating current voltage to very low value.

(6) Adjust frequency to 500 cycles.

(7) Adjust primary inductance to the required wave length, beginning with the longest to be used, and use a wavemeter coupled to the primary inductance for the determination of the wave length. (In making this adjustment do not keep the key closed any longer than necessary and clip the flexible lead to the point on the coil which gives the exact wave length, care being taken to allow room for the other leads.)

(8) Proceed in the same manner as above for the remaining wave lengths. The first tuning of the primary circuit is now complete.

(9) Set secondary (movable) coil approximately $2\frac{1}{2}$ inches from the primary coil and lock it in this position.

(10) Connect antenna loading inductance coils to proper contact stud of secondary coil and from same contact stud run flexible lead to secondary coil cutting into circuit most of this coil.

(11) Adjust antenna circuit to resonance by varying the amount of inductance in the loading coil marked with the same wave length as that on the contact stud. Resonance is obtained when the radiation ammeter shows maximum deflection.

(12) Vary the coupling between the primary and secondary coils of the inductive coupler. If the radiation is greater at a coupling point quite far from the original setting ($2\frac{1}{2}$ inches), change the amount of inductance in the secondary coil, increasing the inductance if the coupling is looser and decreasing if the

coupling is tighter than that desired. Compensate for the change by retuning with the loading inductance.

(13) Repeat this operation for all wave lengths, striving to keep the best coupling point as close as possible to the 2½-inch setting.

(14) Measure the wave length of the antenna circuit at each setting, making sure that the wavemeter is actuated by the antenna circuit and not by the closed circuit.

(15) Should any of the wave lengths, as determined by a wavemeter, be found off, readjust *both* primary and secondary until on wave length. (Due to the inductance of the leads it is always best to start at the longest wave length and work down to the shortest when tuning a transmitting set, because the addition of the various leads has less effect on the longer wave lengths where more inductance is in the circuit than on the shorter.) The transmitting set is now ready for high-power adjustment and tuning.

High-power
adjustments and
tuning.

31-132. (1) *It is very important* that the same number of gaps be used throughout this adjustment, as otherwise the coupling, note, quenching, and wave length will vary, making it next to impossible to tune the set. The procedure is as follows:

(a) Cut in the proper number of gaps and set wave changer switch on longest wave length.

(b) Increase alternating current voltage.

(c) Depress key and adjust frequency to 500 cycles.

(d) Vary alternating current voltage until spark note sounds clear (1,000 sparks per second).

(e) Adjust coupling between primary and secondary slowly and carefully, noting antenna ammeter reading and clearness of note.

(f) Make final adjustment for voltage, coupling and resonance and measure the wave length.

(2) Care must be taken when operating at high power. The key should not be kept closed any longer than absolutely necessary and dashes should be made only when a reading of the various instruments is necessary. Adjustment to proper voltage for clear note is best made while sending letters. The point to be remembered is that the spark gap will be seriously injured if the antenna does not radiate at its maximum.

(3) It will probably be found that the wave-length adjustments will need to be changed somewhat for high power. Final adjustment can be made only by trial. When all adjustments have been made, the transmitter should function efficiently and properly on all the wave lengths. Proper quenching will take place and the gap will not heat excessively. Only one wave will be radiated and the decrement will be the lowest obtainable for that particular antenna system.

(4) *It is very important* that (a) both circuits be in resonance; (b) proper voltage for the number of gaps used be supplied; (c) best coupling exist between the primary and secondary. *In no case* should the antenna circuit be *detuned* (thrown out of resonance with the primary), because (a) there will be a reaction between the two circuits and two waves will be radiated which can be found on a wavemeter coupled to the antenna circuit; (b)

the gap will not quench properly, thereby heating, and power will be retransferred from the antenna to the primary and back again to the antenna, and the decrement will be increased due to this retransfer of power. In other words, the utility and efficiency of the quenched spark system will be entirely lost.

31-133. Whenever it is desired to transmit on maximum power, special adjustments should invariably be made with a view to obtaining maximum output and maximum efficiency, thereby reducing injury to the set. The voltage, number of gaps, coupling, and tuning of the secondary circuit to the primary circuit should be carefully adjusted.

PART 4.—INSTALLATION.

31-136. (1) Install motor generator set in an accessible location, care being taken that the location is suitable from the standpoint of low temperature, dryness, and that the shaft is in a fore and aft position.

(2) The switchboard should be installed handy to the operator and spaced sufficiently from the bulkhead to allow access at the rear.

(3) The transformers should be located under the table near the condenser rack and the primary transformer transfer switch, due regard being given to the protection of the operator from the high potential leads and accessibility.

(4) The condenser rack should be installed as close as possible to the transformer secondary, spark gaps, and closed circuit inductance of the wave changer. Sharp bends and long leads should be avoided.

(5) The spark gaps should be installed in an accessible position and the leads to the rotary gap made as nearly the same as those to the quenched spark gap in order that the wave length will not be changed appreciably when one type of gap is substituted for the other. The rotary gap should be installed with its shaft in the vertical position.

(6) The inductive coupler and wave changer should be installed on the table accessible to the operator's hand.

(7) The antenna loading inductance should be mounted directly above and on the wave changer whenever practicable.

(8) The accessories, including send-receive switch, hand and emergency transmitting keys should be located so that the operator can manipulate them with the least amount of effort. In fact, the whole installation should be made with a view toward rendering the entire set accessible and easy to operate, thereby tending to increase the efficiency of the operating personnel.

PART 5.—CARE AND UPKEEP.

31-138. A transmitting set maintained in excellent condition reflects the efficiency and the morale of the operating personnel. The set will render better service when it is well kept and properly treated. Common sense plus a little knowledge of machinery and a working knowledge of radio apparatus are all that are required to obtain this end.

- Motor generator.** 31-139. The motor generator set should be inspected each morning and the bearings replenished with oil whenever necessary. Oil is supplied to the bearing surface by a ring which carries the oil up from the oil well. As long as oil is carried over by this ring and the bearing does not feel *hot* (compared to the other parts of the motor generator) the bearing is in good condition. Should the oil in the well become too low, the ring will not supply oil to the bearing. This results in expansion of the bearing and shaft, which causes "freezing," or the bearing melts allowing the rotating element to strike the pole faces, thereby putting the motor generator set out of commission. The sight gauge on the bearing indicates the level of the oil in the oil well. Reliance should not be placed on these gauges unless they are known to be in good operating condition, as they become clogged up from time to time. Renew the oil once per month and clean oil gauges.
- Switchboard Instruments.** 31-140. The instruments on the switchboard are properly connected at the navy yard and should not be tampered with. They will stand a moderate overload (off scale) without injury, but there is no occasion to operate under this condition. The direct-current instruments (voltmeter and ammeter) require proper connections to the circuit (positive to positive and negative to negative), otherwise they will read backward, thereby bending the needle. The alternating-current instruments have no polarity and will give a correct indication when connected to the alternating-current circuit (ammeter in series and voltmeter across the line). The frequency meter may be adjusted to read correctly by means of the adjustment arm on the box, when provided, located on the rear of the switchboard. For this purpose the generator should be run at a speed to give 500 cycles (use a revolution counter for determining the speed of the generator), and the two adjusting arms moved to cut in or out inductance and resistance until the frequency meter reads 500.
- Circuit breaker.** 31-141. The circuit breaker in the direct-current line is provided mainly for the purpose of protecting the motor of the motor generator set and should be set to trip at a current value slightly in excess of that required to start the motor generator set. The circuit breaker should be thrown in one pole at a time and *before* the main switch is closed otherwise it will not function as a protective device. Should the circuit breaker release during operation, the cause for this should be investigated and remedied before again closing the circuit breaker. Frequently the circuit breaker will open because the automatic motor starter contacts operate too rapidly and do not allow the motor to get up sufficient speed between steps. The oil dashpot type of automatic starter is particularly hard to adjust, the retarding action of the oil being dependent on the temperature.
- Switches.** 31-142. The switch blades and all contacts should be kept clean and smooth. Arcing at contacts should be prevented except where arcing is expected, as at the circuit-breaker carbon contacts and clapper-switch carbon contacts.
- Fuses.** 31-143. Oversize fuses should not be used, but the cause for fuses burning out should be investigated and remedied. Fuses

will carry a large overload without blowing. This is especially true of momentary overloads.

31-144. (1) The transformers give very little trouble, especially the primary winding. The primary can, however, become short-circuited between turns or be burned out (very rare). An open-circuited primary is indicated by no reading on the alternating-current ammeter when the key is closed, when the rest of the circuit is in good condition. Short-circuited turns are more difficult to discover and are indicated by heavy current and failure to break down the quenched-spark gap. If the secondary winding is intact and the proper capacity being used, short-circuited turns are also indicated by a change in the natural frequency of the circuit and, if key is kept closed for a short time, smoke will be given off.

Transformers.

(2) The secondary coils frequently burn out, caused by radio frequency and high potential surges from the oscillatory circuits. A burned-out secondary is indicated by failure of the transformer to break down the quenched-spark gap with ordinary voltages impressed on the primary; the primary current will also be very low. If one of the coils is short-circuited, the voltage will not be sufficient to break down the gap, and a clear note can not be obtained under any circumstances, due to the 500-cycle circuit being out of adjustment; more primary current than the normal value will flow. The secondary can be tested for open or short circuit by a Wheatstone bridge, care being taken to allow sufficient time after depressing the battery key on the Wheatstone bridge to allow the bridge current to reach a steady value in the coil before depressing the galvanometer key. Have galvanometer key open before opening battery key in order to protect the galvanometer from the inductive "kick."

(3) If the secondary winding is found to be defective, it will be necessary to disassemble the transformer. After disassembly, test each coil separately for continuity and replace defective coil with a spare, care being taken to place the coil properly with regard to direction of winding.

31-145. (1) The quenched-spark gap requires considerable attention. The amount of care required to maintain this gap in excellent condition depends upon the amount of operating done, whether high or low power is used and, above all, on the proper tuning of the transmitter. Increased radiation is the result of a clean gap.

Quenched-spark gap.

(2) A defective unit can be detected by a drop in the radiation, by the spark-gap tester, and by a change in the note. A gap in good condition should show a heavy white spark when tested with the spark-gap tester. A weak spark, or the absence of any spark at the tester point, is an indication that that spark gap is defective.

Defective units.

(3) The defective gaps should be disassembled and cleaned. For this purpose cover a plane faceplate with crocus cloth and, placing the sparking surface of the gap on it, give the gap a rotary motion. One type of gap has a gasket rim equal in height to the sparking surface. The rim and sparking surface can, therefore, be dressed down simultaneously. Another type has its

- gasket rim lower than the sparking surface. With this type care must be taken not to round off the edges of the sparking surface.
- Gap sparking surface.** (4) The sparking surface is of silver or copper, the silver surface being about one thirty-second of an inch deep. In dressing down any sparking surface *do not* attempt to remove all the pits, but dress off the high spots. Test the sparking surface with a straightedge. If no light shows under the straightedge, the surface is true. Where a lathe is available the spark gap unit may be revolved and dressed down by the use of crocus cloth held by a plane surface.
- Fish-paper gaskets.** (5) The standard spark gap gasket is made of 35 mil fish paper. The gaskets should be renewed whenever the spark gap is cleaned. This type of gasket will keep the spark gap airtight but, on account of its compressibility, will gradually reduce the spark-gap length until a short circuit results. The gasket rim for this type of gasket is below the sparking surface so that the normal separation of the sparking surfaces will be 10 mils.
- Mica gaskets.** (6) The mica gasket is rather difficult to handle and is not absolutely airtight, but has an advantage over the fish-paper gasket in that it is not affected by heat, whereas the fish-paper gasket rapidly deteriorates due to the heat of the spark gap. Should mica be substituted for fish paper, care must be taken to build up the mica gasket to a thickness of 35 mils. Mica gaskets do not need frequent renewals. Broken or cracked mica gaskets should be replaced.
- Rotary spark gap.** 31-146. (1) The rotary spark gap operates best when the natural frequency of the 500-cycle circuit is close to 500 cycles. Where a reactance regulator is supplied, the 500-cycle circuit should be adjusted to be resonant to 500 cycles when transmission at full power is required. For ordinary intermittent and medium or low power transmitting, this natural frequency should not be adjusted.
- Clearance.** (2) The clearance between stationary and revolving electrodes is approximately one-eighth of an inch for full power and a 1,000-spark note, while for lower powers and the same note the clearance must be *reduced* until the correct amount is determined. About 50 per cent more current in the 500-cycle circuit is required for this type of gap than for the quenched-spark gap.
- Adjustment.** (3) The gap may be adjusted to any desired length in the following manner:
- (a) Remove cover.
 - (b) Bring rotor electrode exactly opposite a stator electrode.
 - (c) Loosen set screw on shank of stator electrode.
 - (d) Adjust clearance by inserting metal gauge of the desired thickness between the two electrodes.
 - (e) Tighten set screw and at same time keep the two electrode tips in the same plane.
 - (f) After adjustment has been made revolve rotor by hand to test clearance before starting the motor.
- Both the stator and the rotor electrodes can be removed only after the rotor is removed from the motor shaft. It is not necessary to remove either set of electrodes except when badly worn.

(4) Whenever the rotary spark gap is substituted for the quenched-spark gap, a retuning of the radio-frequency circuits is necessary for best operation, because the circuits were tuned with the quenched-spark gap in circuit. Very good results, however, can be obtained by leaving unchanged the adjustments of the open and closed circuits, varying only the position of the coupling coils of the inductive coupler until a maximum indication is obtained on the radiation ammeter. It is to be noted that even after a careful retuning of the transmitter circuits the maximum current in the antenna may be less than that obtained with the quenched-spark gap.

31-147. The inductive coupler and wave changer switch adjustment should not be changed except when there is reason to believe that the tuning and coupling are incorrect. The contact studs should be clean and bright and the wave changer switch should operate smoothly. The contacts should be adjusted so that there is no sparking, and the flexible leads should be arranged during calibration so that the maximum power can be used without sparking occurring between leads.

31-148. The antenna loading inductance should be kept clean and free from corrosion, and the sliding contacts should operate easily and without sparking.

31-149. (1) A little vaseline on the contacts and clips will prevent excessive wear and difficult operation of moving parts. Cleaning compounds should never be used on contacts and clips, and where used care should be exercised that all traces of the compound are removed after cleaning. All bolts and nuts of the set should be kept tight and the proper tool used for tightening them. Contacts are loosened by vibration, and unless tightened are likely to jam the moving parts, with consequent injury to the mechanism. Contact fingers and rollers, and all other contact devices should always make good contact and be set so that they will not be jammed or bent out of shape. Poor contacts are a source of continual trouble, in that they produce sparking and usually insert high resistance into the circuit in which they are located, thereby decreasing the efficiency of the set. If sparking occurs, the contacts become blackened and pitted, frequently requiring a renewal of the parts injured.

(2) Injuries to the transmitter or faults should be corrected with the least possible delay, and not allowed to accumulate, because in so doing a minor fault may develop into one sufficient to put the entire set out of commission. It should also be remembered that a high resistance contact will not be noticed so readily on a transmitter as on a receiver. When a poor contact is included in the part of the transmitter common to the receiver, the transmitter will operate without any noticeable decrease in efficiency but, when receiving, it will reduce the strength of signal or even prevent any receiving. All contacts in the transmitter that are common to the receiver should therefore be inspected frequently and kept in the best possible condition.

(B) AUXILIARY SPARK TRANSMITTERS.

PART 1—GENERAL.

Purpose. 31-150. The auxiliary spark transmitting equipment has been designed to provide an additional radio station on a battleship or flagship which can be operated independently of and simultaneously with the main or any other radio station in the same vessel for short range transmission. The amount of traffic that can be handled by a vessel that has the auxiliary spark transmitter equipment is greatly increased for the reason that the auxiliary set can be used to move local traffic at the same time that the main radio receiving equipment is being used to handle the traffic coming from points outside the fleet.

Interference elimination. 31-151. The problem of interference elimination is simplified by allocating the very short wave lengths (126 to 175 meters) to the auxiliary transmitter. This band of wave lengths is very far removed from the wave lengths of the main transmitter. Interference is further reduced by installing the auxiliary transmitter in a separate radio room, known as the auxiliary radio room, which is located at a considerable distance from the main radio

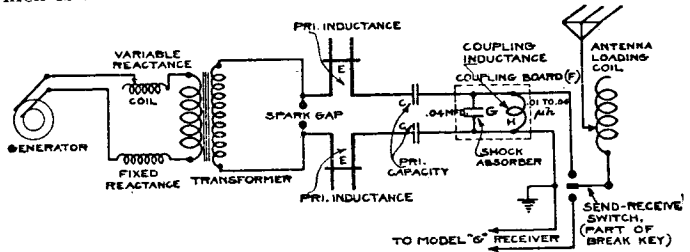

FIG. 31-3.—Circuit diagram of auxiliary-spark transmitter.

room. The special antenna used with the auxiliary transmitter is also placed as far as possible from the fields of the other antennas.

PART 2—THEORY.

General. 31-152. The auxiliary transmitter is a very much improved form of the old-style open-spark-gap type of transmitter and is arranged to operate with a very loose coupling between the closed and antenna circuits. It has, in addition, a special "shock absorbing" feature.

Primary circuit. 31-153. Figure 31-3 is a simplified diagram of the auxiliary spark transmitter. EE are the two halves of the primary inductance which are adjustable to give the wave length range. The purpose of dividing the primary inductance in this manner is to equalize the distribution of potential along each side of the primary circuit. CC are the transmitting condensers, each having a capacity of 0.01 μf . The low-tension terminals of these two condensers are connected to the terminals of the coupling board F. The circuit is continued from the other two terminals on the coupling board to antenna and ground respectively.

Coupling. 31-154. The coupling board F includes a capacity of 0.04 μf made up of eight small mica condensers which are clamped on

the coupling board and a small variable inductance. The coupling between the primary and antenna circuits is of the direct or conductive type.

31-155. The primary circuit condensers CC are charged through the inductance H, the condenser G being short-circuited by this inductance at the charging frequency of 250 cycles. In fact, the difference in potential between the plates of the condenser G when the circuit is charged is only a few microvolts. When the spark passes across the spark gap the circuit oscillates at the frequency determined by the inductance EHE and the capacity CC of the circuit. The cemf of the inductance H now comes into action. The condenser G is no longer short-circuited and the

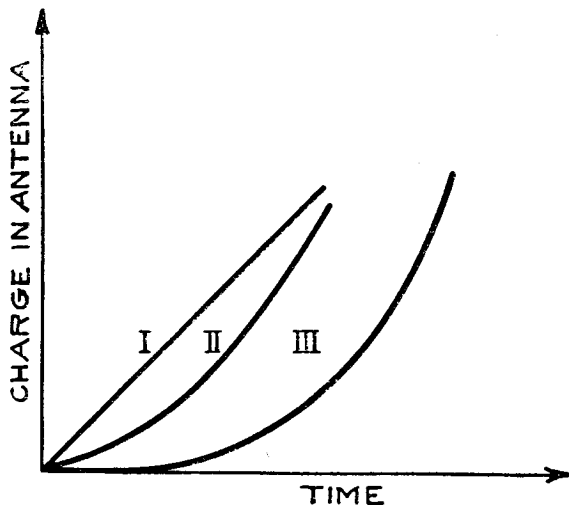

- I SHOWS GROWTH OF CURRENT IN PLAIN ANTENNA.**
II SHOWS GROWTH OF CURRENT IN AN ORDINARY COUPLED CIRCUIT.
III SHOWS GROWTH OF CURRENT IN TYPE SE 3531 ANTENNA.

FIG. 31-4.—Time-antenna charge curves.

difference of potential between the plates rises to about 2,000 volts. The antenna and ground being across this condenser, the antenna circuit is therefore charged by this difference of potential and is caused to oscillate. However, before the potential across the plates of the condenser G can rise at all the condenser must be charged. This procedure delays the charging of the antenna and makes it a more gradual process. Thus, any shock is absorbed and the oscillations in the antenna build up gradually to a maximum value instead of abruptly reaching the maximum amplitude as is the case with other types of spark transmitters.

Figure 31-4 shows the growth of current in the antenna circuit for different types of spark transmitters. It will be seen

Antenna current.

that the current rise is most gradual in the case of the auxiliary spark transmitter. This gradual growth of current in the antenna eliminates excitation of near-by antennas by impact or shock; and for this reason, practically all interference by the simultaneous use of the auxiliary transmitter while receiving on another antenna is eliminated. This feature, together with the use of rejectors in the main radio room, practically removes interference from the auxiliary transmitter. That part of the interference due to sparking in the rigging, etc., will, of course, remain and must be dealt with locally, as the conditions will vary in different ships.

PART 3.—DESCRIPTION.

Types. 31-160. Two types of auxiliary spark transmitters have been developed for the service. They are:

Type SE 3531 (120-volt D. C. supply).

Type SE 3612 (240-volt D. C. supply).

The two types are similar in construction and operation except for the difference in the motor and motor controls due to the difference in the supply voltage.

Features of the various elements.

31-161. (1) The generator is rated at $1\frac{1}{2}$ kilowatts, open-circuit voltage 140 volts, full-load voltage 100 volts, speed, 2,140 revolutions per minute, frequency 250 cycles, synchronous impedance 3.75 ohms. The motor generator has ball bearings and is supplied with the usual spare parts.

(2) The motor field rheostat is designed to give a range of speed of from 10 below to 10 per cent above rated speed, i. e., from 225 to 275 cycles.

(3) The generator field rheostat gives a variation in open-circuit voltage of 40 to 140 volts.

(4) The hand starter is of commercial design and provided with wall supports.

(5) The transformer, type CAT 3543, is designed for a frequency of 250 cycles, primary voltage 100 volts, secondary voltage 11,100 volts. The primary current is 10 amperes and the secondary 0.09 ampere. The transformer is of the single-phase, air-cooled type and is provided with an external reactance mounted in the base of the transformer.

Reactance.

31-162. (1) The reactance has five taps, introducing impedance in the circuit as follows:

Tap No. 1.....	2. ohms.
Tap No. 2.....	2.7 ohms.
Tap No. 3.....	3.2 ohms.
Tap No. 4.....	3.7 ohms.
Tap No. 5.....	4.2 ohms.

(2) These taps are supplied since the impedance of leads from motor generator to transformer is different in different installations, depending on length of leads. When installing, that tap should be used which gives an unbroken note at full gap length. This connection should be made permanently and should not be changed thereafter. In addition, there is supplied a fixed reactance of about 12 ohms, which goes in series with the primary of the transformer and the variable reactance mentioned above.

31-163. Four protective devices, type CD 53, are supplied to prevent radio-frequency oscillations from being carried to the generator and direct-current circuits. Protective devices.

31-164. (1) The spark gap, type SE 3533, consists of a lead-lined wooden box, mounted on a brass bracket and containing one adjustable and one fixed copper electrode, each mounted on a porcelain insulator. Spark gap.

(2) The top of the box is closed in by a cover which is hollow, and is fitted with baffles to deaden the sound of the spark. The air passages through the cover are lined with sheet asbestos. The air inlet from the blower is arranged in the bottom of the box and consists of a metal casting on which is secured a porcelain nozzle.

(3) One end of the box contains the side fitting, consisting of a brass casting to carry porcelain insulator type SE 1239, to which is secured the stationary electrode. The other end of the box carries the adjustable handle and fittings. A sliding sleeve is arranged to slide into, or out of the box, as the handle is revolved and carries on its end an insulator, type SE 1239, into which is screwed a gap electrode. By rotating the handle, the length of spark gap may be adjusted.

(4) The hose from the blower is secured to the metal casting of the inlet. The connections to the spark plugs are made through electrose insulators fitted in the side of the box, flexible leads joining the spark plugs to the terminals on the inside end of the insulators.

31-165. (1) The transmitting condensers, type CD 3536, are of the same physical dimensions as the standard type CD 15S condensers, except that two binding posts are brought out through the bakelite cover, and the case is grounded. Each unit has a capacity of 0.01 μ f, making a total capacity of 0.005 μ f in the primary oscillating circuit. One condenser unit is connected in each side of primary circuit to equalize distribution of potential. The high tension terminals are connected to the primary fittings, and the low tension terminals are connected to the coupling board by 2 x $\frac{1}{8}$ -inch copper strips. Figure 31-2 shows the circuit diagrammatically. Transmitting condensers.

(2) The transmitting condensers, gap and primary fittings are mounted on a common holder.

31-166. The primary fittings form the adjustable inductance of the oscillating circuit, and consists of plain copper rods, four in number, two of which are in each half of the circuit. Clips are supplied for tuning purposes. The end clips should be fitted on permanently at the top of the rods. The second set of clips are put on when transmitting on 150 meters and removed when transmitting on any other wave length. Primary fittings.

31-167. The loading coil, type SE 3532, consists of nine turns of heavy copper wire, mounted on a base, insulated with electrose insulators. The base is fitted directly to the end of the trunk, the coil forming a prolongation of the trunk. Tuning is effected by means of a short flexible lead taken from end of lead-in insulator and clipping on to tuning clips placed on any desired turn on the loading coil. The tuning clips are simple roughened brass Loading coil.

tongues clamped to the antenna coil. The outer end of the antenna coil carries a copper strip which connects to the center terminal of the magnetic break key.

Coupling board. 31-168. (1) The coupling board, type SE 3566, consists of two copper plates clamped together, but insulated from each other by a sheet of bakelite-dilecto. Two clamping bars, one on each side of the copper plates, are also fitted and mounted on the same base. The base consists of a steel frame, the copper plates and clamping bars being insulated from it.

Coupler. (2) In the center of the board, and at right angles to it, is mounted an inductance consisting of two concentric tubes of copper separated three-fourths of an inch. The space between these tubes is bridged by a sliding annular contact. With this contact at its outer limit, the inductance is maximum, having a value of approximately $0.04 \mu\text{h}$, and the coupling is tightest. With the contact at its inner limit, the inductance is minimum, having a value of approximately $0.01 \mu\text{h}$, and the coupling is loosest. A circular hole is left in the upper copper plate, and round it is riveted and sweated a threaded brass ring into which screws the outside cylinder of the inductance, which is afterwards sweated in place. The inner cylinder is similarly fitted to the lower copper plate, a hole being left in the bakelite-dilecto plate to enable this to be done.

Clamping bars. 31-169. The clamping bars on each side of the coupling board each carry four mica condensers, type SE 3537. The condensers are easily removed and replaced by unscrewing the holding-down clamps and the screws holding the ends of the condenser-tab clamps. These clamps force the condenser tabs down onto the copper knife edges on the copper plates of the coupling board, thus joining the condensers between the copper plates.

Coupling board condensers. 31-170. The coupling board condensers are each composed of two elements joined in series, the joint capacity being $0.6055 \mu\text{f}$. All eight condensers are joined in parallel between the sides of the coupling board, giving a total capacity of approximately $0.044 \mu\text{f}$. The condensers are built up of mica and copper foil, the two elements of each condenser being permanently joined in series and held together by a piece of empire cloth, held in place by shellac. Each element is tested to stand 2,000 volts effective. The diagrammatic connections of the coupling board are shown in figure 31-2.

Break key. 31-171. The break key, type SE 3538, is electrically operated and performs two separate functions, i. e., it is a relay key operated by Morse key, opening and closing the primary circuit of the transformer, and acts as a send-receive switch. The key is shown diagrammatically in figure 31-5.

(2) A plunger "E" carries an arm "P" having a copper contact "Z," which makes contact with a fixed copper contact "R" controlling the main alternating current circuit. The plunger carries a second arm "L" which alternately makes and breaks on two side contacts "M" and "M'" which are joined to the transmitting set and the receiving cabinet, respectively. These contacts are V-shaped springs, against which arm "L" alternately makes contact as the Morse key is released or depressed.

(3) In figure 31-5 the key is shown in the sending position. The receiving contact is grounded by means of the limit stop "O." When the Morse key is released, contact between "Z" and "R" is broken, opening the primary circuit of the transformer; lever "L" breaks contact with transmitter contact "M" makes contact with receiver contact "M'" and breaks contact between latter and ground. When the Morse key is depressed, the plunger is

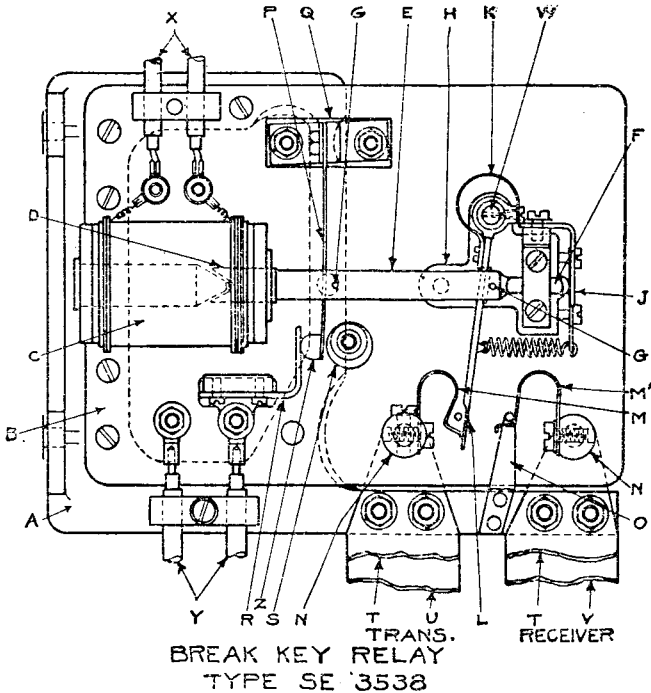

A	BASE CASTING	O	GROUND CONNECTION BAR
B	BASE	P	SPRING CONTACT ARM
C	COIL	Q	ADJUSTING BLOCK
D	ARMATURE	R	FIXED CONTACT
E	ROD	S	STOP
F	GUIDE ROD	TT	GROUND STRIPS
GG	TAPPET PINS	V	TRANSMITTING CONNECTIONS
H	BEARING BLOCKS	V	RECEIVING CONNECTION
J	LIMIT STOP	W	ANTENNA TERMINAL AT BACK
K	FLEXIBLE CONNECTION	X	D.C. TO OPERATING COIL
L	MOVING CONTACT ARM	Y	A.C. MAIN LEADS
MM	CONTACT SPRINGS	Z	CONTACT
NN	TERMINAL BLOCKS		

FIG. 31-5.—Break key relay, type SE 3538.

drawn upward, Lever "L" breaks contact with receiver spring "M'" and makes contact with transmitter through spring "M," and the primary circuit of the transformer is closed by contacts "Z" and "R." It should be noticed that each time lever "L" engages with, or leaves receiver contact, the antenna is grounded for an instant through ground connection "O."

(4) The coil of this key is operated through the contacts of Morse key, and has a 50 candlepower lamp in series with it of

same voltage as the supply. The break key is mounted on the base plate of loading coil.

Copper strips. 31-172. (1) Copper strips 2 inches by one-sixteenth inch are used for connecting the send-receive switch, the break key, and the ground plate to the coupling board and receiving cabinet. They are also used as leads in the primary oscillating circuit between condenser terminals and coupling board. These strips are run parallel, as close together as possible, to keep down their inductance, and are separated from each other by small porcelain insulators, type SE 1241, placed at intervals of approximately 10 inches. The insulators are bound in place with binding wire.

Balance of Inductance.

(2) In order to insure that a small amount of inductance is used in the receiving cabinet, it is necessary that the inductance of the copper strips on the transmitting side be slightly greater than the inductance of the strips, etc., on the receiving side, because incoming signals are received through the loading coil, and exact tuning of receiving instruments is of vital importance. This may be accomplished, if found necessary, either by making one of the copper strips in the transmitting side a few inches too long, and bending it into an arc, thereby increasing its inductance, or by separating the copper strips on the transmitting side between the porcelain insulators.

Blower.

31-173. The blower, type SE 3611 (with 220-volt motor) and type SE 3545 (with 110-volt motor), has a capacity of 60 cubic feet per minute at a pressure of approximately 5 ounces (8 inches water). It is equipped with direct connected $\frac{1}{2}$ -horsepower direct-current motor, and operates at a speed of 2,700 revolutions per minute. With each blower is supplied a hose coupling 5 feet long; one end of the hose is attached to blower exhaust, and the other to a brass fitting, which attaches to nozzle opening in bottom of spark gap. The blower is started by throwing it directly across line by a two-pole single-throw switch.

Morse key.

31-174. The Morse key, type SE 3546, differs from the usual Morse key in that it is provided with back contact, is completely inclosed in a grounded brass case with operating knob extending through, and has a condenser of 0.1 mfd. capacity connected across the front contacts. In wiring this key, lead-covered leads should be brought through rear of key cover, and the lead sheaths grounded by clamping between grounding strips secured to inside of case. Ten spare contacts and one spare insulating knob are supplied with each key.

Various kinds of meters.

31-175. (1) The frequency meter, type CV 1252, is of standard Weston design used in the construction of the 500-cycle meters. It is calibrated to read over a range of 200 to 300 cycles.

(2) The antenna ammeter, type CV 1280, is provided with external thermoclement, which is placed between coupling board and ground. Lead-covered leads 15 feet long are provided from thermoclement to meter. The meter is calibrated with these leads in circuit. Range 0-4 amperes.

(3) The direct-current ammeter is 7 inches diameter, surface mounted and front connected. It has a range of 0-30 amperes.

(4) The alternating-current voltmeter is 7 inches diameter, surface mounted and front connected. It has a range of 0-150 volts.

PART 4.—OPERATION.

31-177. (1) Figure 31-5 represents key with coil energized, plunger and send-receive switch portion of key in sending position. To adjust the key, tension must first be put on the spring contact "P" by twisting the adjusting block "Q" so that spring bears hard against limit stop "S." When satisfactory tension is obtained, the adjusting block "Q" must be clamped in position. The fixed phosphor-bronze contact "R" should then be adjusted in position so that, when the coil is energized and the plunger drawn in, the length of soft-iron armature visible outside the spool is about one-sixteenth inch. If the armature is pushed entirely in until it touches the core, the end of the armature will be flush with the end of the spool, but as the minimum air gap should not be less than one-sixteenth inch, this amount of armature should extend outside the spool when coil is energized. The limit stop "S" is mounted eccentrically and may be adjusted until the maximum break between "P" and "R" is about one-sixteenth inch, or whatever break is found desirable in practice. The smaller the break, the quicker the key will close the alternating-current circuit after Morse key is depressed, but it must be large enough to insure a positive break.

Adjustment of
break key.

(2) The send-receive portion should then be adjusted, the limiting stop on the upper terminal block "N" being fixed in such a position that, when plunger is in, the spring contact "M" is forced away from the limit stop by about three thirty-seconds of an inch. Care must be taken, however, that it is not possible for the moving contact arm "L" to come up against limit stop. The lower spring contact "M'" and its limiting stop "O" should then be adjusted. The clearance between the two spring contacts should be about five-sixteenths inch, so that there will be no danger of sparking over from the transmitting to the receiving position.

Send-receive
adjustment.

(3) When in the "receive" position, the lower spring contact M' must be forced away from the grounded limit stop "O" by about one thirty-second of an inch. The object of "O" is to ground the antenna and receiver momentarily in order to discharge any charge which may remain on the antenna as it leaves the transmitting position. The limit stop "J" should be finally adjusted to prevent the central moving system falling farther than necessary. The total movement of this central moving system should be about three-sixteenths of an inch.

Receive position.

(4) Particular care must be taken in adjusting the key to insure that the send-receive switch remains in the transmitting position until after the low voltage transmitting current has been broken, and vice versa, when Morse key is depressed, send-receive switch must be in transmitting position before contact between "R" and "Z" is closed.

Send position.

31-178. (1) The following procedure should be followed in tuning the auxiliary transmitter:

Tuning the set.

- (a) Disconnect the antenna.
- (b) Start motor generator set.
- (c) Adjust speed to give 250 cycles.

- (d) Set spark gap to not over one-sixteenth of an inch.
- (e) Reduce alternating current voltage until it is just sufficient to spark across the gap.
- (f) Pull the coupling plunger on the coupling board one-half way out. Leave it in this position throughout the operation of tuning.

Tuning clips. (2) There are two sets of tuning clips provided on the inductance rods. One set is springy while the other is stiff. The stiff clips should be set close to the top of the primary inductance rods and clamped in this position. They are intended to be used when a second and longer wave length is assigned.

Primary circuit tuning. (3) The set of spring clips should be set on the primary inductance rods at the points which will give a primary circuit wave length of 150 meters. The procedure for this operation follows:

- (a) Press the key.
- (b) Set wavemeter so that it is coupled with the primary circuit.
- (c) Adjust position of spring clips until the primary circuit is tuned exactly to 150 meters.

Care must be taken to have the same amount of inductance in each side of the circuit; that is, the spring clips should be at the same distance from the insulators at the bottom.

Antenna circuit tuning. (4) After the primary circuit has been accurately adjusted the antenna circuit should be tuned. The method in which the antenna circuit is tuned to resonance with the primary circuit when *the maximum reading is obtained on the antenna ammeter must not be employed* because of its inaccuracy for this type of transmitter. The wavemeter method should be used. The wavemeter should be coupled to the antenna lead somewhere above the radio room. With the wavemeter in this position vary the position of the tap on the antenna loading coil, type SE 3532, until the radiated wave is exactly 150 meters.

Increasing inductance. (5) If more than one and one-half turns of the antenna loading inductance are required to obtain 150 meters more inductance should be added by forming a loop in the parallel copper strips leading from the coupling board to the antenna break relay, as shown in figure 31-6.

Inductance common to transmitter and receiver. (6) It should be remembered that the inductance in the antenna loading coil is also in series with the Model "G" receiver when receiving. If too many turns of inductance are used in the loading coil it will be impossible to use enough inductance in the primary of the receiver to obtain best receiving conditions. Therefore, never use more than one and one-half turns in the antenna loading coil, but increase the inductance as explained above.

Adjustment of alternating-current supply circuit. 31-179. (1) After the transmitting set has been adjusted to the correct wave length set the gap at three-eighths inch. Press the key and adjust alternating current voltage to about 140 volts, frequency 240 cycles. If a good clear note is not obtained, vary the alternating current voltage slightly above or below 140 volts. If this does not give a good clear note, with no breaks or spits, the reactance of the primary circuit must be adjusted.

(2) Adjustment of the primary circuit is accomplished by shifting the position of the terminal on the variable reactance coil which is located in the base of the transformer. Choose the tap which gives a clear clean spark note as observed in a receiver. This condition can and should be obtained.

Reactance.

31-180. The coupling between the primary and antenna circuits is *closest* (tightest) when the plunger of the coupling board, type SE 3566, is pulled way out.

Coupling.

31-181. To obtain increased power it is better to use tight coupling rather than a long spark. The gap should not be opened up more than three-eighths inch. On the other hand, the spark is inclined to arc if the gap is shortened to less than one-eighth inch.

Power.

PART 5.—FAULTS AND REMEDIES.

31-185. (1) In general the faults and remedies for this set are the same as for the Navy standard 500-cycle quenched-spark transmitter previously described. All parts of the transmitting set should be kept clean and bright.

General precautions.

(2) The successful operation of this type of transmitter depends practically entirely on the condition of the spark gap and the adjustments. The spark gap surfaces should be cleaned fre-

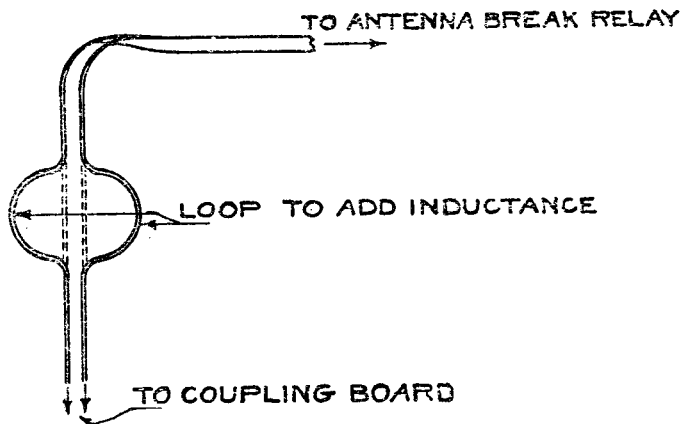

FIG. 31-6.—Method of arranging leads to increase inductance.

quently and either trued up or renewed when worn to such an extent that the sparking surfaces are not parallel.

(3) The gap supporting insulators should be wiped clean daily. The porcelain insulator which serves as a tip for the blower should be correctly placed so that the three lines of air meet on the center line of the gap. This is very important in order that proper quenching of the spark will occur.

31-186. (1) If interference is experienced when receiving in the main radio room while transmitting with the auxiliary spark transmitter it is generally an indication that (a) the set is not operating properly or (b) there is sparking in the rigging, etc.

Causes of interference.

(2) The first part of the interference can be removed by proper adjustment of the transmitting set itself. The second part of the interference, due to sparking in the rigging, etc., will, of course,

Possible remedies for interference.

remain and must be dealt with locally, as conditions will vary in different vessels. A very probable cause of interference and one that would be difficult to eradicate is the spark that may occur at points where there is a bad or partial electrical contact between the different parts of stanchions, stays, guys, and running rigging, etc. Discontinuities in the lead casing of electric cables and places where thimbles and eyes are served with hemp or partially insulated from the wire rope or shackles will possibly cause trouble. This can be remedied by making good electrical contact across them. A very minute spark may cause serious trouble, especially if the wave length of the circuit in which it occurs should happen to be the same as that of the auxiliary transmitter. Sparking in the rigging under these conditions has an effect similar to that produced by other types of spark transmitters and is very difficult to remove.

Use of reflector. (3) The interference in the main radio room by the auxiliary set should be extremely small and the ordinary adjustments of the reflector will eliminate it.

Sparking in rigging. (4) Interference in the auxiliary from the main radio transmitter is much harder to remove. All sparking in the rigging must be absolutely stopped before anything further is done. All stays must have their ends efficiently grounded.

Location of auxiliary antenna. (5) It is important that the auxiliary antenna should be at the greatest angle possible relative to the main antenna and down leads. In addition it should not be run parallel to any stays.

(C) MOTOR BUZZER TRANSMITTERS.

PART 1—GENERAL.

Purpose. 31-200. The motor buzzer transmitter is of simple construction, low powered, and is used for all short-range communication purposes. Its normal range in daylight should be from 50 to 100 miles when it has been correctly adjusted.

Special qualities. 31-201. The motor buzzer transmitter makes a very desirable addition to the transmitting equipment of a battleship, because its radiation is even less than that obtainable with the 2 kilowatt quenched-spark transmitter. Further, because it is operated with looser coupling between the closed oscillatory and antenna circuits, it does not interfere with nearby receiving stations to the same extent as would a quenched-spark transmitter using the same power input.

Types. 31-202. The motor buzzer, as first developed, was not a complete transmitter in itself; it was built for use in conjunction with part of the standard quenched-spark transmitter of 2, 5, or 10 kilowatt capacity in order that spark transmission could be carried on with powers lower than the lowest obtainable with only one gap of the main transmitter. It can not be used satisfactorily with a transmitter smaller than 2 kilowatts, for the reason that the transmitting condensers of sets smaller than that size have too small a capacity for the proper operation of the buzzer. The model BC motor buzzer transmitter is of the type just mentioned, and is supplied for use on either 120-volt or 240-volt supply. The model BD motor buzzer differs from the model BC in that it

is a complete transmitter by itself. This set is for use on vessels which are not fitted with quenched-spark transmitters, such as the arc-equipped vessels.

PART 2—THEORY.

31-203. A simplified diagram of the essential parts of the motor buzzer transmitter is given in figure 31-7. It will be seen from the figure that the usual alternator is not used in this type of set, but an interrupter instead. The entire circuit from the DC supply to the wave changer is rather novel in its operation. The theory of the transmitter is as follows:

General.

31-204. The direct current from the ship's supply (80, 125, or 240 volts) is led to the buzzer wheel W through two iron core

Direct-current supply.

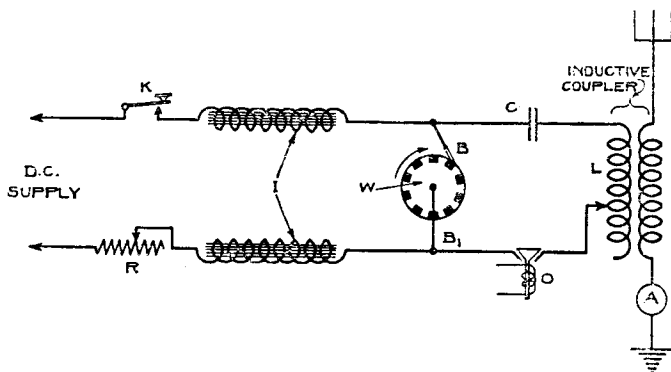

Fig. 31-7.—Simplified diagram of motor buzzer transmitter.

inductances I, the power regulating rheostat R and the key K. The buzzer wheel W is rotated by a small motor at a constant speed, and is made of brass with ten insulating segments set into its periphery. The brush B bears alternately on metal and insulation as the wheel revolves. The brush B₁ is used to make the connection from the brass wheel to the circuit. It will be seen that the purpose of the buzzer wheel is to interrupt the direct current.

31-205. (1) Assume that the key K is closed, and that the wheel W revolves until the brush B makes contact with the metal of the wheel. This completes the direct-current circuit as stated above. The direct current starts to flow in the circuit KIBWB₁IR; but, on account of the large inductance of the two coils I, it takes an appreciable length of time for the direct current to reach its maximum value. A strong electromagnetic field is set up about each of the inductances I. Energy is stored in these fields.

Function of buzzer wheel.

(2) Assume further that the wheel again rotates sufficiently to bring the brush B on an insulating segment. The direct-current circuit is then broken, and a high voltage exists at the brushes BB₁. This voltage is generated by the collapse of the electromagnetic lines of force on the turns of the coils, and is much higher than the supply voltage, because the lines of force collapse much more rapidly than they build up. The effect is the same as

Closes supply circuit.

the inductive "kick" when a motor or generator field switch is suddenly opened.

Opens supply circuit.

(3) The circuit through the wheel W is broken by the insulating segment, and this suddenly generated high voltage causes a current to flow in the circuit CLO, and the capacity C is charged. In this manner the energy which was first stored in the fields around the inductances is now stored in the capacity C, which is the condenser of the closed oscillatory circuit of the transmitter.

Acts as spark gap.

(4) As the buzzer wheel W revolves, the brush B gradually approaches the metal segment of the wheel; but just before it touches the metal, the voltage of the condenser C causes a spark to jump the gap between the wheel and the brush B. When this spark passes, oscillations are set up in the circuit BCLOB. The frequency of these oscillations corresponds to the wave length to which this circuit has been tuned.

Transfer of power.

(5) The power is transferred from the closed circuit to the antenna circuit by means of induction, through the inductive coupler of the wave changer. The operation just described is repeated as the wheel revolves.

(6) It should be noted that the buzzer wheel performs two functions, that is, it interrupts the direct current and forms the

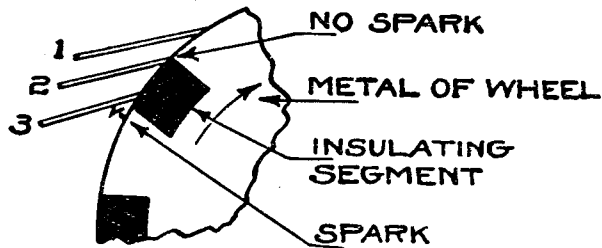

Fig. 31-8.—Buzzer wheel with brush in various positions.

spark gap. No spark occurs when the brush leaves the metal to pass on to the insulation, but does occur when the next metal segment approaches the brush. The spark, therefore, takes place on the under side of the brush B, between it and the approaching metal segment. Figure 31-8 shows the brush B in three successive positions with respect to the buzzer wheel. Position 1 shows the brush making contact with the metal, which is the position at which the supplied circuit is closed. Position 2 (no spark) shows the brush resting on the insulating segment, during which time the condenser C is being charged. Position 3 shows the brush close enough to the approaching metal segment for the spark to pass.

Radiation.

31-206. The rheostat "R" is used to vary the radiation of the motor buzzer. When all resistance is in the circuit, the radiation is extremely low, of the order of several milliamperes. With all resistance out, the radiation should be approximately 2 amperes.

Spark frequency.

31-207. The speed of the buzzer wheel may be varied by a field rheostat supplied with the set, through a range of from 2,000 to 3,000 revolutions per minute corresponding to a variation in spark frequency of from 333 to 500 sparks per second. The spark

frequency of standard Navy spark transmitters is 1,000 per second. It will be noted, therefore, that the note of the buzzer transmitter is inherently low compared with that of a quenched-spark set. When the set is properly adjusted, the note is clear and very distinctive.

31-208. The inductances I are also adjustable. The best adjustment for various wave lengths, powers, and wheel speed must be found by trial. The value of inductance used is most largely a function of buzzer-wheel speed and power.

Inductances.

PART 3.—DESCRIPTION.

31-209. Figure 31-8 is a schematic diagram of the model BC motor buzzer circuit. A brief description of the various parts of the circuit follows:

31-210. (1) The buzzer assembly consists of the buzzer motor, interrupter wheel, brush rigging and motor buzzer relay, all mounted on a single base.

Buzzer assembly.

(2) The motor is one-fourth horsepower shunt wound, equipped with thrust bearings, so that all end play is eliminated. While

Buzzer motor.

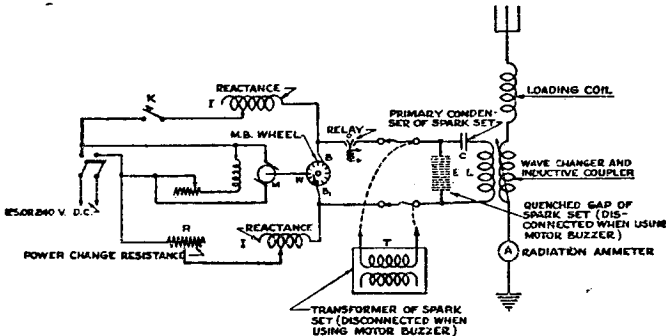

Fig. 31-8.—Circuit diagram of motor buzzer transmitter.

this motor only requires approximately 50 watts for operation under the load imposed by the brushes, a one-fourth horsepower motor is used to secure the reliability and ruggedness not usually inherent in motors of lower rating. Ample spares are supplied which should maintain the set in satisfactory condition indefinitely.

(3) The buzzer wheel, type SE 1515 A, has mica inserts firmly secured in the rim, this material having been selected on account of its wearing qualities, and for its insulating properties.

Buzzer wheel.

(4) The brush holders are designed to insure that the brushes make contact with wheel at angles which have proven most satisfactory. The brush pressure is adjustable through a range which insures most efficient operation.

Brush holders.

(5) The motor buzzer relay, type SE 3633, mounted on motor buzzer base, is a component unit of the break system. This relay is provided to open the oscillating circuit of the motor buzzer transmitter between dots and dashes, both to eliminate the possibility of the motor buzzer motor noises being communicated to

Motor buzzer relay.

the receiver, and to prevent loss of received power in the oscillating circuit of the motor buzzer transmitter. It is equipped with ground clamps for 4,000 circular mil lead covered cable, and includes a type SE 3651 coil. This relay should not be included in the circuit of the motor buzzer transmitter until a complete break-in system is installed, at which time additional instructions will be issued covering its operation. Until the break-in system is installed, the solenoid of the motor buzzer relay should be left out of the circuit, and a jumper placed across the relay contacts, permanently closing the break.

Impedance unit.

31-211. The impedance unit, type SE 3559B, consists of two separate coils, one in each side of the direct-current supply to the buzzer wheel, wound on a common open laminated core. Taps are brought out from each coil to a dial switch on top, a separate switch being provided for each coil. The total inductance of each side of the impedance unit is approximately 3 henries.

Power changing resistance.

31-212. (1) The power changing resistance, type SE 3639, is of the enameled type, built for bulkhead mounting, and is enclosed in a substantial perforated case. The resistance steps provided are as follows:

	Ohms.
1 -----	0
2 -----	25
3 -----	40
4 -----	80
5 -----	250
6 -----	675
7 -----	1,300

(2) The supply voltage will be impressed across the resistances intermittently and they are so constructed that full supply voltage must not be impressed across any step and common terminal continuously. It has been necessary to make this restriction to hold the dimensions of the power-change resistance within allowable limits.

Antenna ammeter panel.

31-213. The antenna ammeter panel, type SE 1698, includes a type CV 2179 O-2 ampere antenna ammeter, and a transfer switch for cutting this meter in and out of the antenna circuit. An auxiliary blade is supplied which opens the solenoid coil of the clapper switch in the 500-cycle circuit of the main transmitter. When the transfer switch is in what is normally the "open" position, the O-2 ampere ammeter is cut into the antenna circuit in series with the antenna ammeter of the main set. At the same time, the second blade of the switch opens the clapper switch solenoid circuit, making it impossible to transmit on the main set when the O-2 ampere ammeter is in circuit.

Motor speed regulator.

31-214. The motor speed regulator, type SE 1489, consists of a rheostat connected in series with the motor field, and is capable of varying the motor speed through a range of 2,000 to 3,000 revolutions per minute on a voltage supply of either 80 or 120 volts. A stud is located in the face of the switch, which should be so assembled that, when the set is used on 120-volt supply, the movement of the switch is restricted, preventing the operation of the motor at speeds above 3,000 revolutions per minute.

On a supply voltage of 80, the stud should be so assembled that the switch has full range, including all contacts. This is the only change in the operation of the set from 80 to 120 volts.

31-215. The cover provided for the buzzer and brush rigging in model BC transmitters is intended to eliminate the noise incident to the buzzer spark. In addition to the cover, special soft-rubber feet and bushings are supplied to be used in mounting the buzzer on the operating table. These mountings are so constructed that the only mechanical contact between the buzzer base and the table is through them. By this method of mounting, any vibration in the motor base due to the high speed of the buzzer motor is not communicated to the operating table.

Mounting.

PART 4.—OPERATION.

31-217. (1) When the motor buzzer set is installed, the spark set should be tuned in conjunction with the motor buzzer so that transmitting may be transferred from spark set to buzzer set without further tuning being necessary.

(2) This balance may be established by adjusting the connections to the quenched gap on main set so that the total inductance of the primary oscillating circuit of the main set is equal to the inductance of the oscillating circuit of the motor buzzer set, which consists of the buzzer wheel, buzzer brushes, motor buzzer relay, motor buzzer leads, condensers of main set, including leads and primary of the inductive coupler of main set. This may be readily accomplished as follows:

Balancing.

(a) Before tuning the quenched-spark transmitter, open the antenna circuit and connect leads from the front of the wave changer panel to any point on the primary coil of the inductive coupler. Operate the spark set at low power, and measure the wave length of the primary oscillating circuit by a wavemeter.

Tuning primary of quenched-spark transmitter.

(b) Shut down the quenched-spark motor generator, plug in motor buzzer leads to terminals of quenched gap on wave changer panel, start motor buzzer, adjusting impedance and power until a good note is obtained. Measure the wave length of primary oscillating circuit by a wavemeter, leaving the connection on the primary coil of the inductive coupler intact. It will probably be found that the wave length with motor buzzer is approximately 10 meters longer than with quenched gap, due to the greater inductance of the motor buzzer connections.

Plugging motor buzzer into circuit.

(3) Due to the fact that the motor buzzer spark is not quenched as rapidly as the spark of the main set, it will radiate a broader wave than the quenched-spark set. This is due to the inherent characteristics of the buzzer set, and can be corrected only by using the loosest possible coupling when sending on the motor buzzer i. e., move the secondary coil of the inductive coupler as far from the primary coil as the construction permits. This will result in a somewhat lower radiation than would be obtained by tight coupling, but the decrement will be lower—i. e., the radiated wave will be sharper, and will therefore cause less interference on other waves. Loosening the coupling, when transmitting on the motor buzzer set will not require readjustment of antenna or primary circuit tuning.

Relation of coupling and decrement.

Wave lengths. 31-218. The motor buzzer transmitter is intended for use on the same wave lengths as the quenched-spark set with which it is installed, and should be used whenever its output is sufficient to cover the required range, in order to eliminate the unnecessary interference caused by radiating more power than is required.

To transfer to motor buzzer set. 31-219. To transfer from quenched-spark set to motor buzzer set, the following operations should be performed in the sequence given:

- (1) Stop motor-generator of spark set.
- (2) Insert plugs of motor buzzer leads in quenched-gap terminals on front of wave changer panel.
- (3) Throw "key transfer switch" to "buzzer" position.
- (4) Throw switch on radiation ammeter panel to "buzzer" position.
- (5) Have at least three gap units of main spark set gap in circuit to insure spark occurring at peripheral brush of buzzer rather than in gap of main set.
- (6) Loosen coupling of inductive coupler (wave-changer) of main set as far as possible in order to decrease the decrement of the buzzer set. If it is found that sufficient power can not be obtained by cutting out power changing resistance, coupling may be tightened slightly. The buzzer should never be used, however, with less than 4 inches separation between primary and secondary coils of the inductive coupler.
- (7) Cut out all resistance in buzzer motor field rheostat, and close buzzer main line switch. The closing of this switch will start motor by placing it directly across the line.
- (8) Transmit by Morse key.

Indication of radiation. 31-220. When the antenna ammeter transfer switch is thrown to "buzzer" position, the radiation of the motor buzzer is indicated on the 0-2 ampere antenna ammeter. The maximum radiation obtainable by this set is approximately 2 amperes.

Character of spark. 31-221. The motor buzzer spark should be crisp and clear cut, occurring *under* the brush, i. e., between the peripheral brush and the *leading* tip of the metal segments. At low powers, the spark is quite small, and makes no noise. At full power heavy sparking occurs. This is not to be considered as undesirable because the more powerful the spark the greater the range obtained. The peripheral brush will wear away comparatively fast at full power, and will require renewal of the sparking end, either by cutting off and trimming the old brush or replacing by a new one.

Always use as much resistance in the circuit as possible, consistent with the range required. This will not only reduce interference, which is the chief object of the motor buzzer transmitter, but will also aid in keeping the brushes and wheel in good condition.

PART 5.—FAULTS AND REMEDIES.

Cleaning the wheel. 31-223. The wheel should be kept bright and clean by the use of *metal polish* only. Abrasives, such as sand paper or emery cloth must not be used, since they will cause a deposit of metallic particles in the insulating segments and reduce their effectiveness.

Improper position of sparking. 31-224. Under certain conditions, it will be found that the spark becomes long, taking place between the peripheral brush and the

trailing tips of metal segments. Under such conditions, practically no radiation will be obtained. This is caused either by using too high power, by the oscillatory circuit being open, or by an improper adjustment of impedance. If, while transmitting it is noticed that radiation falls appreciably, it is very probably due to the above reason. The impedance and power should be readjusted.

31-225. The leading tips of the metal segment will, in time, become pitted. If this becomes bad enough to interfere with satisfactory operation, a light cut should be taken off the periphery of the wheel. This cut should be carefully made, in order that the wheel will remain perfectly true. The wheel may be dressed in this manner as often as necessary until the depth of the insulating segment reaches approximately $\frac{3}{8}$ inch, when wheel should be replaced.

Truing wheel.

31-226. A poor note may be due to:

Poor note.

(1) Wheel not running true, which will cause brushes to chatter and give rise to a broken note.

(2) Sparking over at the wheel, as described above.

(3) Dirty or pitted wheel.

(4) Loose brush holders.

31-227. Failure to get a spark at buzzer wheel may be due to the following:

No spark.

(1) Less than three gap units of main set in circuit, in which case spark is possibly passing there.

(2) Secondary circuit of main set transformer has not been opened.

31-228. Motor buzzer leads, type SE 3643, are designed so that their inductance is as small as possible, in order that the motor buzzer may be connected to the oscillatory circuit of the main spark set without varying the constants of this circuit sufficiently to require retuning.

Inductance of motor buzzer leads.

SECTION III.—ARC TRANSMITTERS.

PART 1.—GENERAL.

31-250. The arc transmitter is used in the service for most medium and all high power continuous wave transmission. It is used on shipboard as well as at shore stations. Practically all the transmission effected by means of the arc is of the CW telegraph type. The 2-kilowatt and 5-kilowatt arcs are additionally equipped with the chopper for ICW transmission. The use of the chopper, however, materially decreases the range of the arc transmitter.

Purpose.

31-251. The arc transmitter supplies current to the antenna continuously (except when the chopper is used). The decrement of the transmitted wave is zero except when high-speed signaling is done. For this reason CW signals will tune in very sharply on the receiver; in fact, when CW signals tune in broadly, the trouble lies in the receiving system. The antenna circuit of the receiver may have a high decrement and this, coupled with the action of the secondary circuit of the receiver used for autodyne reception (beat method) causes most of the inter-

Continuous wave transmission.

ference phenomena. The secondary circuit of the receiver is purposely detuned from resonance from the incoming signal and the antenna circuit of the receiver in order to obtain enough beats per second to render the signal audible. This detuning is most marked at the longer wave lengths, and the remedies for this condition have been incorporated in the model RB receiving equipment.

Effective decrement.

31-252. As soon as signaling is done with CW transmission, and especially at very high speeds, the continuous wave is given an effective decrement which is closely related to the speed at which the signaling is done. This is caused by the fact that the oscillations in the antenna gradually build up to their maximum amplitude when the key is pressed and decrease gradually when the key is opened. Hence, as the signaling speed is increased, the time consumed during the building up and dying down of oscillations becomes an appreciable part of the total time oscillations are present in the antenna. Signaling accomplished by hand does not have sufficient speed to give the continuous wave transmission an appreciable decrement.

Advantages.

31-253. The arc transmitter is a simple means of obtaining continuous waves and is used in the service because of its simplicity, ease of operation and great flexibility. It can be used on practically any antenna, does not require high speed, complicated generators and controls, such as the high-frequency alternator, and can transmit on practically any wave length.

PART 2.—THEORY.

Arc as converter.

31-254. The arc converter, as its name implies, is a device which converts direct-current power into alternating-current power. The input to the arc is direct current while the output is alternating current. The frequency of the output current generated by the arc depends upon the electrical constants of the circuit in which it is included; in the usual case it depends upon the inductance and capacity of the antenna.

Resistance characteristic.

31-255. An arc is capable of self-generating oscillations because of the way in which the resistance of the arc depends upon the current flowing through it. In an arc, the current is carried by the vaporized material of the electrodes. The heavier the current through the arc, the hotter it becomes, the more vapor is supplied to conduct the current, and hence the resistance of the arc is lowered. In fact, the resistance decreases at a faster rate than the current increases so that the voltage drop across the arc, which is given by the product of the arc current and the resistance, is less for large currents than it is for small.

Simple arc circuit.

31-256. The customary circuit used for generating oscillations is that shown figure 31-9. The direct-current generator supplies the current to the arc through the field coils. These coils serve three purposes. They supply the magnetic field and, by virtue of their high inductance, act as choke coils so as to keep the direct current constant, and also prevent radio-frequency currents from flowing through the generator circuit. The arc is struck by short-circuiting the electrodes and then the arc is drawn out until it becomes active and oscillations begin.

31-257. The operation of the arc is directly dependent upon the negative resistance characteristic stated above. When the arc is functioning the flow of current from the antenna on discharge adds to the current from the generator, thereby reducing the resistance and facilitating the discharge. With reversed flow of the oscillating current through the arc into the antenna, the arc resistance increases, due to the smaller total current through it. This causes the direct current generator current to be diverted in part into the antenna, thus supplying the energy to the antenna system required to keep it oscillating. Generator current is supplied to the antenna during the whole charging period. Once the initial oscillation is started, following oscillations increase in amplitude until limited to a steady value by losses. Approximately 50 per cent of the generator energy is delivered to the

Operation of arc.

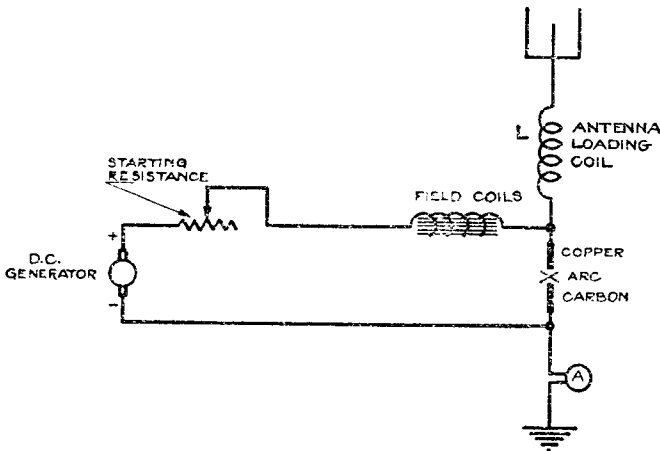

FIG. 31-9.--Simplified arc transmitter circuit.

antenna. The remaining 50 per cent supplied by the generator during the discharge half of the cycle is largely dissipated in the arc and carried off by the cooling system.

31-258. When the arc is functioning properly, the amplitude of the oscillating current will be equal to the value of the direct current supplied to the arc, so that the total arc current drops to zero when these two currents are flowing in opposite directions through the arc. When flowing in the same direction through the arc, the total current will be twice that of the direct current supply. The antenna ammeter reads the effective value of the oscillating current, which is 0.707 times the maximum amplitude. If, therefore, the amplitude of the antenna current is equal to the direct current arc current, the reading of the antenna ammeter will be 0.707 times that of the direct current ammeter.

Amplitude of oscillating current.

31-259. (1) Signaling for arc transmission is accomplished by two general methods:

Signaling systems.

- (a) Compensation.
- (b) Uniwave.

(2) Method (a) uses two wave lengths just far enough apart to permit reception of one without serious interference from the

Compensation method.

other. The sending key controls a certain definite amount of inductance in the antenna circuit either by direct shorting of one or more turns of the loading inductor or by shorting loops which are inductively coupled to the loading coil. In both cases power is radiated continuously, one wave being emitted when the sending key is open and the other wave when the key is closed.

Uniwave method.

(3) Method (b) transmits only one wave, the arc output being diverted into an absorbing circuit when the transmitting key is open. Figure 31-10 shows the elementary circuit of the type

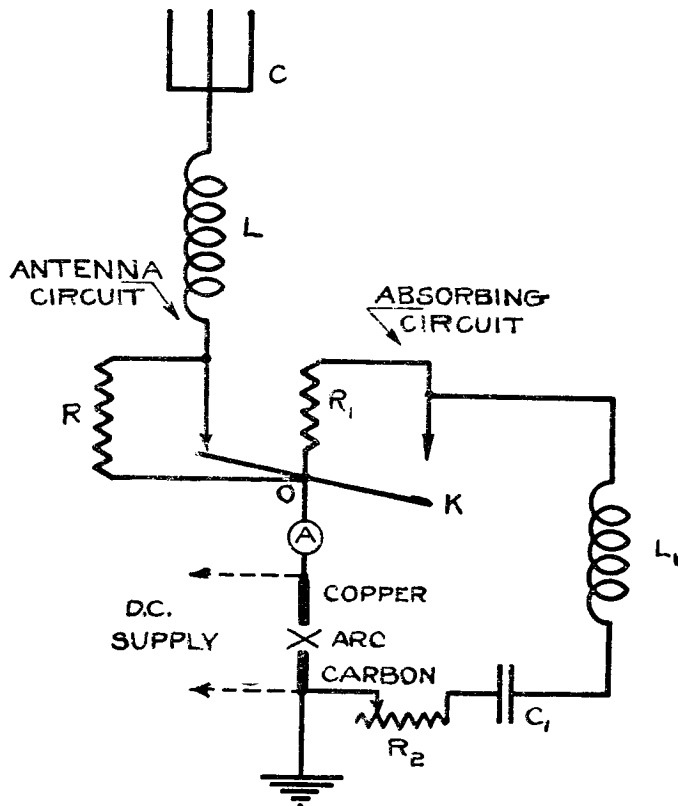

FIG. 31-10.—Arc uniwave key circuit.

SE 1822 uniwave key for 30 kilowatt arcs. The key K operates to divert the arc output into either the antenna circuit, as shown, or into the absorbing circuit. R and R₁ are moderately high resistances connected across the contacts to eliminate sparking on the break.

Current transforming circuit.

31-260. A simple arc circuit is shown in figure 31-11 with the condenser C replacing the antenna. By the addition of L₁, figure 31-12, in parallel with L across C, the total condenser current is divided between L and L₁. But, as previously stated, the oscillating current through the arc bears a fixed relation to the direct current measured by A₁. It is evident that only the arc oscillating

current will pass through L . But the energy to maintain the oscillating current in the circuit L_1L can only be supplied from the arc. This can not be by increase of current. Therefore, the voltage must be increased. It is in effect as though the arc were working into a circuit of higher resistance.

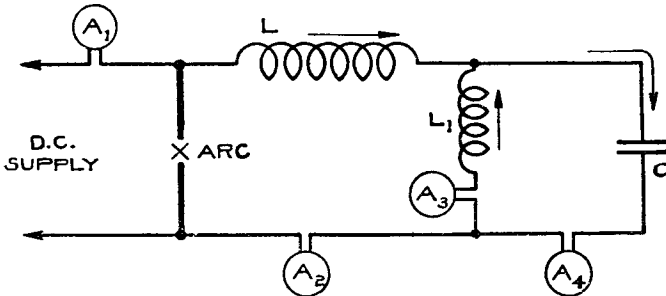

FIG. 31-11.—Arc current-transforming circuit.

Application.

31-261. This circuit, with the condenser C replaced by an antenna is known as the current transforming circuit. It finds application where the antenna is of low resistance, when, instead of having to work at a low voltage on account of the limited current which can be passed through the arc coils, it is possible to handle a reasonable current at a greater voltage and at the same time utilize the full capacity of the antenna. The division of current between L and L_1 is in inverse ratio to their values, but the practical limit is a 1 to 1 ratio and frequently less under the operating conditions met in arc installations.

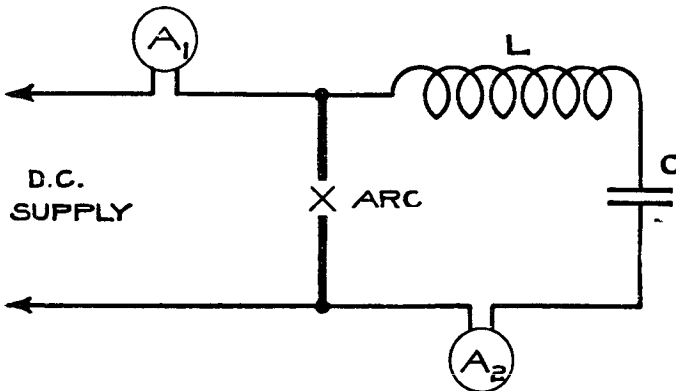

FIG. 31-12.—Simplified current-transforming circuit.

31-262. Figure 31-13 shows the actual circuit which it is found necessary to install. C_1 and C_2 are large series condensers to prevent short circuiting the generator through L and L_1 . C_r and C_r are connected around C_1 and C_2 , respectively, to prevent long wave oscillations being set up in the circuit $C_1L_1C_2$. The current transforming system will be applied to 2 kilowatt and 5 kilowatt arc transmitters for use on shipboard.

Practical circuit.

31-263. The following arc transmitters are now in use in the service.

Type No.	Power in kilowatts.	Normal arc voltage.	Use.	Method of signaling.
Model K.....	2	350	Naval vessels....	Chopper, back shunt.
Model Q.....	2	500	Merchant vessels..	Do.
Model X.....	2	500	Naval vessels....	Chopper, ignition key.
	5	500do.....	Do.
Model CT 1201.....	20	500do.....	Compensation wave. ¹
	20	500do.....	Do.
Model CT 1038.....	20	500do.....	Do.
Model CT 1042.....	30	500do.....	Do.
	100	500	Shore stations....	Do.
	200	500do.....	Do.
	500	500do.....	Do.

¹ The uniwave key is to be installed with 20 kilowatt and 30 kilowatt arc transmitters.

NOTE.—The motor of the motor generator set is wound to correspond with the local power supply.

PART 3.—DESCRIPTION.

General.

31-264. (1) Following is a description of the arc transmitter, the 20-kilowatt arc transmitter (Contract No. 15 of 1918) being chosen as a type set.

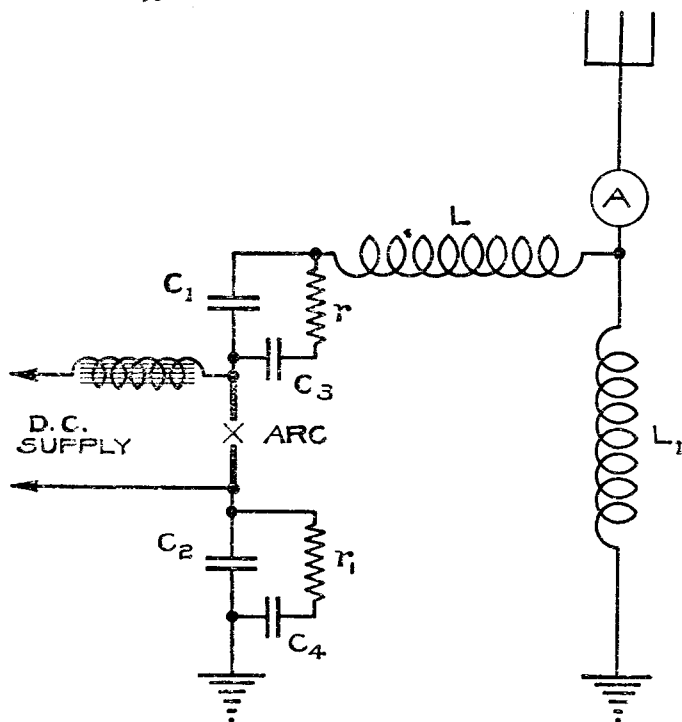

FIG. 31-13.—Actual current-transforming circuit for arcs.

- (2) The fundamental parts consist of the following:
- Power equipment.
 - Arc converter.
 - Wave changer and inductance system.
 - Auxiliary apparatus.

31-265. (1) The power equipment consists of the motor generator with its controls, and series starting resistances for the arc converter. Power equip-
ment.

(2) Power is supplied to the arc by a direct-connected motor generator set, consisting of a 31-horsepower direct-current motor (for shipboard use) and a 20-kilowatt 600-volt direct-current generator. Power sup-
ply.

(3) Disconnecting switches for the direct-current generator armature and field are mounted on a small panel. Switches.

(4) Motor starting panels are provided for both hand and automatic starting of the motor. The automatic control is operated by push-button switches on the operator's table or on the contactor panel itself. A transfer switch on the contactor panel is used for selecting local or remote control. A separate panel carries a transfer switch to change from hand to automatic control, or vice versa. Motor start-
ing panels.

(5) The control switchboard is mounted in the operating room and carries all the necessary apparatus (with the exception of the push-button switches) for remote control of the motor, generator, and arc converter. The push buttons for starting and stopping the motor are mounted in a position convenient to the operator, usually on the table in front of the switchboard. Control switch-
board.

(6) A 16-step drum controller for operating the arc converter is mounted on the switchboard. It performs in the proper sequence the operations of starting the cooling water pump, the hydrocarbon feed, and the carbon rotating motor, of closing the relay key control circuit, the arc main line contactors, the arc extinguishing contactor, and the generator field circuit, of releasing the arc striking mechanism, of raising the direct-current voltage to 600 volts in small steps, and of cutting out the arc starting resistance. Drum control-
ler.

(7) The arc-adjusting mechanism is a part of the arc drum controller and is mechanically interlocked with the latter so that the arc can be struck only at the proper generator voltage and with the arc starting resistance in circuit. Arc adjusting
mechanism.

(8) The hydrocarbon control consists of two sight feed cups with the required amount of piping. The cups are mounted on the switchboard. The amount of flow of the liquid hydrocarbon is regulated by adjustable needle valves. Flow to the arc is magnetically started by the drum controller (step two). One cup is for alcohol and the other for kerosene. Hydrocarbon
control.

31-266. (1) The arc converter consists of one bedplate, two series field coils, counterpoise, two pole pieces, chamber, anode, cathode, anode and cathode fittings, water-cooling system, arc-striking mechanism, outlet pipe for exhaust gases, rotating motor, and gearing necessary for rotating the cathode. Arc converter.

(2) The series field coils are placed one below and one above the arc chamber, the lower one resting on the bed plate and the upper one on the top of the chamber. These two coils are connected in series in the positive side of the arc supply line, the circuit being completed through the anode, arc, cathode, back to the generator. Series field
coils.

- Counterpoise.** (3) The counterpoise is placed on top of the upper series field coil.
- Pole pieces.** (4) One pole piece passes through each series field coil and projects into the arc chamber.
- Arc chamber.** (5) The arc chamber is a hollow bronze water-jacketed box equipped with two flanges at each end to which are attached the anode and cathode jackets. A hinged door is fitted to one side of the chamber and an exhaust pipe to the other side. The arc is formed between the anode and cathode which lie between the vertical pole tips protruding through the upper and lower sides of the chamber. The arc is blown by the magnetic field horizontally outward toward the door, which is water-jacketed to take up the heat.
- Anode.** (6) The anode is made of copper of rectangular cross-section and is hollow. It is fitted with a pipe through which water is delivered by the water-cooling system against the face of the anode. The water returns around the pipe and out through a separate hose connection. The anode tip is held in place on the anode fitting by a nut.
- Anode fitting.** (7) The anode fitting consists of a water-jacketed cylinder which is bolted to the arc chamber. It is insulated by an asbestos bushing at the outer end of the cylinder or anode jacket. The latter furnishes a relatively cool dead gas space around the anode between the bushing and the hot gases in the chamber. Rubber gaskets are used to make gas-tight joints between the anode and bushing and between the bushing and the cylinder. The anode may be removed for inspection or replacement of the copper tip by loosening the hand wheel and swinging the yoke upward.
- Cathode.** (8) The cathode consists of a carbon electrode, a carbon holder, a water-cooled sheath which surrounds the holder and removes the heat transmitted to it by the carbon, and mechanism for slowly rotating the carbon and its holder in the sheath, and a device for adjusting the length of gap between the carbon and the anode tip.
- Carbon holder.** (9) The carbon is held in the holder by a split taper collet. The length of the projecting carbon can be adjusted by loosening the knurled knob. The carbon holder can be varied easily and quickly removed for the substitution of a new carbon electrode.
- Cathode sheath.** (10) The cathode sheath furnishes the bearing surface on which the carbon holder slides and rotates. The former motion is for striking the arc and adjusting the arc length. The cathode is built for remote control at the switchboard. The carbon electrode rotating motor rotates the carbon holder, being connected to it by a worm gear. The rate of rotation is very slow. The motor is secured to the arc chamber.
- Water-cooling system.** (11) The water-cooling system consists of the storage tank (capacity of about 200 gallons), pipe connections, valves, motor driven pump, rubber hose connections to the water jackets of the arc chamber, anode, and cathode. The passage of the water is from the bottom of the storage tank through the centrifugal pump, circulation indicator, the anode, the anode jacket, the chamber door, the arc chamber, the cathode sheath, and back through the return pipe to the top of the tank. It will be noted

that the cooling water is supplied first to the anode tip, because it is necessary that the anode be kept as cold as possible for the proper operation of the arc and in order to prevent melting of the anode tip. Fresh water only is used in the water-cooling system. The storage tank is equipped with a coil through which sea water is passed in order to cool the circulating water. This is especially necessary when the arc is used continuously over long periods and in hot weather.

(12) The outlet pipe for exhaust gases is equipped with a valve to prevent leakage of air into the chamber, but will allow any undue pressure within the chamber to leak off into the atmosphere. Outlet pipe.

31-267. (1) The inductance system consists of the antenna loading inductance and the adjusting inductance, both mounted as a unit on a common frame. All the coils are placed with their axes at right angles to one another in order to reduce the coupling between them. Inductance system.

(2) The antenna loading inductance, type CT 557, is a multiple disc coil wound with special litzendraht on a bakelite frame. A tap is brought out from each layer or disc of the coil and connected to a terminal on the terminal plate in order to facilitate making the proper connections. There are thirteen discs in the antenna loading inductance. Antenna loading inductance.

(3) The adjusting inductance, type CT 559, is a helical coil wound with bare stranded copper cable. A rotating framework inside the coil carries a trolley wheel which makes contact with the cable at any desired point. The adjustment is made by revolving a handwheel in front of the wave changer. By means of this mechanism the exact point on the coil which is best for a given connection can be determined. After the location of this point has been determined a clamp is attached to the outside of the coil to provide a stationary connection. Adjusting inductance.

31-268. (1) The uniwave system, type SE 1822, will shortly be supplied as equipment for all 20 and 30 kilowatt arcs, therefore, the old absorbing circuit and relay key system will not be described here. Uniwave system.

(2) The uniwave system consists of the following parts:

- (1) Transmitting key, including noninductive resistance units.
- (2) Absorbing circuit resistance.
- (3) Absorbing circuit inductance.
- (4) Absorbing circuit capacity.
- (5) Double contact relay.
- (6) Morse key.

31-269. (1) The relay key consists of eight pairs of contacts, one contact of each pair being stationary. Four pairs are used for making and breaking the absorbing circuit and four for the antenna circuit. Each pair of contacts is bridged by a non-inductive resistance, and the four contacts of each of the two groups of contacts, antenna and absorbing circuits, are connected in series. When either the antenna or absorbing circuit group of contacts is open four of the resistance units are in series with Transmitting key.

the antenna or absorbing circuits, respectively, increasing the resistance of that circuit by a like amount.

- Relay key.** (2) The relay key is actuated by two solenoids, the energizing of which is controlled by a separate double contact relay.
- Adjustment of transmitting key.** (3) The adjustments of the transmitting key must be maintained at all times so that all contacts of each group make and break simultaneously. While this requirement is imperative, its fulfillment is comparatively simple, since the key has been designed to facilitate this adjustment. If this adjustment is not properly made, it will evidence itself by heavier sparking at the contact which is not in alignment. When working properly, the sparking at the contacts should be extremely minute. It has been found that the antenna contacts spark even less than those of the absorbing circuit, no sparking at all being visible the greater part of the time.
- Antenna ammeter.** The antenna ammeter is connected in the common lead from the arc to the antenna and back shunt circuits, so that the meter indicates the current in either circuit.
- Absorbing circuit resistance.** 31-270. The absorbing circuit resistance consists of 24 cast-iron grids. It is provided with a switch for cutting sections in and out. The total resistance of the unit is 3.5 ohms. The primary function of this unit is to absorb the energy of the arc when the Morse key is up. It is made variable, so that the amount of current taken by the antenna and absorbing circuits alternately may be equalized.
- Absorbing circuit inductance.** 31-271. The absorbing circuit inductance is similar in form to the loading inductance units used in standard Navy 10-kilowatt spark transmitters. It is made variable so that the impedance and wave length of the absorbing circuit may be under control. The adjustments of this circuit are taken up later.
- Absorbing circuit capacity.** 31-272. The absorbing circuit capacity for 30-kilowatt arcs consists of a bank of eight standard 0.004 μ f mica condensers, connected in two groups in series, each group containing four units in parallel. With this combination, the uniwave system has been operated for considerable periods without showing any evidence of temperature rise.
- Double contact relay.** 31-273. The double contact relay, which is of a common commercial type, is actuated from the contacts of a Morse key and is provided with a double-contact armature, each contact controlling one electromagnet of the transmitting key.

PART 4.—OPERATION.

- General instruction.** 31-274. The operation of the arc transmitter is relatively simple, and no trouble should be experienced in starting and maintaining oscillations at the wave lengths for which this arc is designed to operate, especially if the antenna insulators are clean, dry, and of good quality. The successive steps necessary to bring the arc output up to its full rating are so arranged that they will occur in proper sequence, as the arc drum controller is turned from step to step in a clockwise direction.

31-275. To start the set after a long period of idleness:

Starting set
after long peri-
od of idleness.

(1) See that the water-cooling system is in proper condition with all necessary valves open.

(2) Put the antenna transfer switch in the sending position.

(3) Take necessary steps to protect the receiving set.

(4) Adjust the arc gap to about $\frac{1}{2}$ inch. The arc length is adjusted by turning the handle on the front of the controller. The direction in which it should be turned is shown on its face.

(5) See that the following are closed: Motor circuit breaker, motor main line switch, all auxiliary circuit switches, generator field switch, and the emergency switch.

(6) Start the motor generator set by means of the push button switch.

(7) Start the water circulation pump by advancing the controller to step 1, and see that water circulates through the system.

(8) Start the hydrocarbon feed, close the relay key controlling circuit, and start the carbon drive motor by advancing the controller to step 2.

(9) Close the arc main line contactors by advancing the controller to step 3.

(10) Close the generator field circuit by advancing the controller to step 4. This gives a generator open circuit voltage of about 300.

(11) Close the arc extinguishing contactor by advancing the controller to step 5.

(12) Advance the controller to step 6, and thereby release the arc striking mechanism. Strike the arc and adjust for the maximum steady reading of the radiation ammeter. The arc is struck by pulling out the hard-rubber handle on the controller until the carbon strikes the anode, and then releasing quickly. The arc length is indicated on its face. The arc should be preferably too long rather than too short.

(13) Advance the controller until the voltage at which it is desired to operate is indicated. As the voltage is raised the arc length should be kept adjusted so as to give the maximum steady reading of the radiation ammeter.

31-276. If it is desired to operate on low power the series resistance should be left in circuit. The controller should, therefore, not be advanced beyond position 9, as this resistance is short circuited on position 10.

Low power op-
eration.

31-277. If the arc breaks or goes out, return the controller to step 6 and repeat operations 12 and 13 above.

Arc goes out.

31-278. To stop the arc for a short period, return the controller to step 2 and leave it in that position. This allows the hydrocarbon flow to continue and thus insures the presence of gas in the chamber when the arc is started again.

To stop arc
for short period.

31-279. To start the arc after a short period of idleness:

Starting arc
after short idle-
ness.

(1) Put the antenna transfer switch in sending position.

(2) Take necessary steps to protect the receiving set.

(3) Adjust the arc gap to about $\frac{1}{2}$ inch.

(4) Repeat operations 9 to 13, inclusive, under the directions given for starting after a long period of rest.

- Securing arc.** 31-280. To stop the arc for a long period.—(1) Return the drum controller to the “off” position.
- (2) Stop the motor-generator set by means of the push-button switch marked “Stop.”
- (3) Put the antenna transfer switch on the receiving or grounding position.
- To change the wave length.** 31-281. (1) To select any one of the five different available wave lengths, the wave changer hand wheel is simply turned so that the pointer indicates on the dial the “Send” position for the wave length desired.
- (2) *Care should be taken never to go beyond the end positions on the dial.*
- To adjust the wave length.** 31-282. In case any wave length is not exactly that shown on the dial, it should be adjusted to the proper value by observing the following procedure:
- (1) Put the wave changer in the “Adjust” position for the wave length in question.
- (2) With the arc operating on the antenna circuit, turn the small hand wheel which operates the mechanism of the adjusting inductance until the wavemeter indicates the exact wave length desired.
- (3) Shut down the arc.
- (4) Go behind the wave changer and find the lead from the adjusting inductance to the blade on the wave changer which corresponds to the given wave length.
- (5) Remove the clamp on the end of this lead from the adjusting inductance and put it back at the point on the helix where the trolley wheel of the adjusting inductance stopped.
- (6) The wave changer may then be put in the “Send” position for the desired wave and the arc started.
- To operate the antenna transfer switch.** 31-283. (1) The antenna may be connected to ground, to the receiving set, or to the arc converter for sending by means of the remote control handle of the antenna transfer switch.
- (2) To select any one of the three connections, it is only necessary to turn this handle until its pointer indicates the desired position on its dial.
- To replace the anode tip.** 31-284. When it is desired to change an anode tip, the arc should be shut down with the controller on the “off” position and the following directions observed:
- (1) Close the valves in the water circulation system on both sides of the arc.
- (2) Loosen the anode locking wheel and swing the yoke upward.
- (3) Draw out the anode and set it on end with the tip upward.
- (4) Remove the tip locking nut with the wrench provided and remove the anode tip.
- (5) See that the bearing surfaces of the anode, the lintel, and the new anode tip are clean, smooth, and entirely free from grit.
- (6) Spread a small amount of graphite over these bearing surfaces, put the tip in place, and replace the tip nut. This should be tightened enough to prevent leakage of water, but not enough to damage the lintel.
- Lin ing up anode tip.** (7) Replace the anode in the arc and tighten the locking wheel.

(8) See that the tip is lined up equidistant from the pole tips. If it is nearer one than the other, loosen the locking wheel, adjust the anode for position, and again tighten up the wheel. If the tip has not been properly replaced on the end of the anode, it will of course be necessary to remove the nut and see that it is put on squarely before it can be lined up correctly between the pole tips.

31-285. (1) The carbon electrode is held in the carbon holder by means of a split taper collet. This is tightened or loosened by a knurled handle on the end of the cathode. To increase the length of the projecting carbon.

(2) When the carbon is burned back so that it projects only a short distance from the end of the carbon holder, it should be readjusted so that it projects about 4 inches. This adjustment may be made without removing the carbon holder from the sheath.

(3) The following procedure should be observed in making the adjustment:

(a) Unscrew the small knob at the extreme end of the cathode. This leaves an opening into which the carbon adjusting rod or gauge may be inserted.

(b) Loosen the collet by turning its knurled handle to the left.

(c) Push the carbon forward to the desired position by means of the adjusting rod. This is a graduated rod with a handle on one end. By means of the graduations it can easily be seen how far the carbon has been moved.

(d) Tighten the collet on the carbon.

(e) Replace the plug at the end of the cathode.

31-286. When the carbon has been burned down so far that a new one is required, the change should be made according to the following directions: To replace the carbon electrode.

(1) Loosen the collet by turning its knurled handle to the left.

(2) Remove the carbon holder from the sheath. This is done by pushing in on the carbon-holder handle, turning a quarter turn in either direction, and then pulling it straight out.

(3) Pull out the old carbon and insert a new one so that it projects about 4 inches from the end of the collet. Tighten up the collet enough so that the carbon will remain in position while replacing the holder in the sheath.

(4) Put the carbon holder back in the sheath by reversing the process described under (2).

(5) See that the collet is sufficiently tight on the carbon.

31-287. On long runs of the arc, cold salt water should be circulated through the copper coils of the cooling water tank to carry away the heat from the arc cooling water. For ordinary runs, the heat storage capacity of the tank is sufficient to render this unnecessary. Short and long runs.

31-288. The chamber should always be tight when the arc is running to prevent the entrance of air or the escape of gas. The presence of either air or the least amount of water in the chamber causes unsteadiness of the arc. Care should be taken, therefore, to see that there are no water leaks in the chamber due to loose connections. Chamber should be tight.

31-289. The bearing surfaces of the anode, anode tip, and lintel where these parts join should be kept clean and free from grit. Care of bearing surfaces.

If grit is present on any of these surfaces, it may grind in enough to ruin them for making a water-tight joint. If a small quantity of graphite is spread evenly over the bearing surfaces before the anode tip is put in place, it will aid in obtaining a water-tight joint.

Adjustment of main-line contactors. 31-290. The main line contactors are interlocked with the motor starting contactors and with the current limit relay so that they will not close if the motor generator is not up to speed, or if the current limit relay has been tripped and not reset. In case, therefore, the main line contactors do not close on the proper controller position when the motor generator set is operating at full speed, the current limit relay probably needs to be reset.

Hydrocarbon supply. 31-291. The hydrocarbon supply to the arc may be selected at will from either the alcohol or the kerosene cup by raising the small lever at the top of that cup to a vertical position. Flow is regulated by an adjusting screw at the top of the cup, which is locked by means of a wing nut.

Field strength. 31-292. The field strength is made variable by means of switches which cut in or out sections of the series field windings. This field strength should be maintained at the point where maximum antenna current is obtained for any given wave length. The field strength required for proper operation of the arc varies inversely with the wave length—i. e., the longer the wave length the less the field strength that is required.

Peculiarities of arc operation. 31-293. (1) When the arc is operating properly, the operator will notice that a certain peculiar and steady hissing sound is given forth by the arc. This sound can be heard directly. The hydrocarbon feed cup will then be filled either constantly or at regular intervals with a bluish vapor, and the hydrocarbon feed will be steady.

(2) The surest indication that the arc is operating properly is when the radiation ammeter reads exactly seven-tenths that of the direct-current ammeter in the arc supply line.

(3) If the arc is too long, a surging sound will be heard; if the arc length is too short, a squealing sound will be given forth. A little experience will aid the operator in determining instinctively whether or not the arc is working properly.

Adjustment and operation of uniwave signaling system. 31-294. (1) The fact that the constants of the absorbing circuit are not critical as regards current balance or wave length makes it possible so to adjust this circuit initially that no readjustment is required when the transmitted wave length is changed through wide limits.

Wave length of absorbing circuit. (2) The absorbing circuit should be initially adjusted to a wave length approximately one-half that of the wave length of the transmitter. This may be done when the system is installed by disconnecting the antenna entirely from the arc and adjusting the wave length of the absorbing circuit by the use of a wavemeter.

Connections. (3) The circuit should then be connected up as per the accompanying diagrams, with the antenna ammeter in the common lead from the arc to the transmitting key. Adjust the two groups of contacts on the transmitting key so that each group

of four make and break simultaneously. This can be done with sufficient precision by visual inspection.

(4) Start the arc on low power and test the operation of the key by transmitting. If any one of the pairs of contacts shows more sparking than the others, it is evidence that that contact is not in proper alignment, and should be readjusted.

Sparking.

(5) The current in the absorbing circuit should then be adjusted to be approximately equal to the antenna current. This may be readily accomplished by an adjustment of the absorbing circuit resistance, with further adjustment of the absorbing circuit inductance if necessary. While it has been found that a balance between the two circuits is not essential for satisfactory operation, the balance should nevertheless be made, so that the load on the power equipment will be held practically constant.

Current in absorbing circuit.

PART 5.—FAULTS AND REMEDIES.

31-295. The faults that can occur in the arc transmitter equipment are in the main quite different from those of any other type of transmitter. Faults arising in the power equipment will be indicated by the direct-current instruments and their remedies are obvious. The faults peculiar to the arc itself are generally due to air and water leaks in the chamber and chamber fittings, poor condition of the copper and carbon electrodes, etc.

General.

31-296. The usual faults and their remedies are given in the following table:

Fault.	Cause.	Remedy.
1. Rapid burning away or melting of the anode.	(1) Poor circulation of water due to failure of pump to close valve, collapsed rubber hose. (2) Reversed polarity of arc supply circuit, thus making the anode the cathode. (3) Tip incorrectly lined up causing arc to burn to one side rather than along center line.	(1) Inspect water cooling system throughout. Make such repairs as necessary to insure strong water circulation. (2) Reverse arc supply circuit so that positive line is connected to the anode (Copper). (3) Line up the tip.
2. Explosions in arc chamber.	(1) Air leaks in air chamber.	(1) Close up all air leaks and inspect the seal to the exhaust pipe.
3. Poor radiation...	(1) Field strength not properly adjusted. (2) Insufficient hydrocarbon feed. (3) Poor adjustment of arc length (too short).	(1) Increase or decrease field strength until radiation is improved. (2) Supply more feed. (3) Open out arc until radiation ammeter shows maximum ¹
4. Excessive power input.	(1) Poor insulation anywhere in oscillatory circuit. (2) High resistance anywhere in oscillatory circuit.	(1) Poor insulators will usually be detected by local heating after a run. Insulators should be kept clean and dry. Very little trouble will be experienced with porcelain insulators. (2) Remove sharp bends wherever possible. Clean and tighten all connections. Look for excessive heating in the loading coil. If heating is excessive, determine cause and if injuries to coil are due to arc across banks, injured section should be cut out of circuit (rare).

¹ As the arc is opened out, the radiation will increase and then decrease. Set the arc length at the point to give maximum radiation.

NOTE.—As stated under *theory*, the arc can be adjusted so that the radiation will have a value of seven-tenths of the direct-current supply. This will continue to be the case as long as the arc can oscillate. If the arc is feeding a circuit having high resist-

ance due to poor insulation, leaks to ground and any other defects which will increase the resistance, the voltage of the direct circuit supply must be increased (perhaps doubled), in order to give the same radiation as obtained before the circuit had become defective. In a shore station installation, any improvement made in the insulation and any reduction in the resistance of the circuit, will reduce the required voltage. In other words, less power input will be required in this case to give the same radiation as that obtained before the improvements were made.

PART 6.—CARE AND UPKEEP.

General pre-
cautions, etc.

31-297. The amount of care and upkeep required by the arc transmitter is slight. Careful attention, however, should be paid to the following points:

(1) Keep the power equipment in first-class condition by observing the usual rules for the care and upkeep of machinery, such as oiling moving parts when required, keeping the commutators clean, and the brushes at the right tension.

(2) Sandpaper only should be used on the commutators and brushes, and very sparingly. It is better to allow the commutators to acquire a deep chocolate color and glossy surface than to keep them copper bright by the use of sandpaper.

(3) All switches and contactors should be frequently gone over with a piece of cloth previously dipped in light oil. This prevents corrosion, gumming, sticking, and rapid wear of the sliding contacts.

(4) Keep the arc chamber free from air and water leaks.

(5) Do not use excessive amount of alcohol or kerosene.

(6) See that anode and cathode lie midway between pole tips.

(7) Use only straight carbons with flat burning surfaces.

(8) Keep anode insulator gaskets clean.

(9) Do not allow carbon or soot to accumulate in the arc chamber.

(10) Do not fill alcohol cup while set is in operation.

(11) Do not attempt to work around set while switches are closed. In case of trouble or work aloft, open all switches and do not close them until word has been received from proper authority that work or trouble aloft has been remedied. This is especially important because the antenna has a potential of 500 volts direct current to ground whether arc is burning or not after arc supply switch is closed.

(12) Do not open chamber door immediately after shutting down the set as an explosion is likely to occur.

(13) Keep all tools clear of the arc converter.

(14) Renew water in cooling tank from time to time.

(15) Make a ground test on rubber hose frequently.

(16) Keep all tools and oily substances off insulator blocks.

(17) Do not use emery on the carbon sleeve of water jacket but wipe the sleeve with kerosene to remove soot, and afterwards oil with light oil.

(18) Do not bring naked flame near chamber while door is open.

(19) Use extreme care when opening the chamber and do not stand in front of chamber door when opening it.

(20) Keep inflammable material away from chamber exhaust.

SECTION IV.—VACUUM TUBE TRANSMITTERS.

(A) THE VACUUM TUBE USED AS A TRANSMITTER

PART 1.—GENERAL.

31-325. Vacuum tube transmitters are essentially continuous wave apparatus, being similar to the arc transmitter in this respect. The vacuum tube transmitter is superior to the arc in purity of emitted wave form, in the ease with which it can be keyed, in its adaptability to modulation by speech for radio telephony or to modulation by other means for the production of interrupted (modulated) continuous waves, and in its successful operation at comparatively short wave lengths.

General.

31-326. (1) Vacuum tube transmitters are very flexible. A single tube equipment may be designed for three types of transmission:

Types of transmission.

- (1) Continuous wave.
- (2) Telephone.
- (3) Interrupted continuous wave.

(2) The first type of transmission is used for telegraphy, and is received in the same manner as reception of signals from an arc (autodyne or heterodyne reception). This is the most efficient of the three types.

(3) The second type of transmission (telephone) consists of continuous waves of radio frequency modulated by the voice (audio frequency). Straight detection is used when receiving telephone transmission. In other words, when used for telephony, the vacuum tube transmitter can be received in the same manner as any of the spark transmitters. The reliable telephone range of any given tube transmitter equipment is approximately one quarter of that obtained with the same equipment on continuous wave transmission.

(4) The third type of transmission, ICW, is effected by modulating the continuous waves at an audio frequency. This is done in one instance by using 500-cycle alternating current for the plate supply of the tubes. Another scheme of interrupting the continuous waves is to open and close the grid leak circuit periodically. The device now in general use for ICW (telegraphy), however, is the substitution of an ordinary buzzer in place of the microphone transmitter. In this case the radio frequency is modulated at a constant audio frequency dependent on the frequency of the vibrations of the buzzer diaphragm instead of the varying audio frequency due to voice modulation. Either straight detection, or the autodyne or heterodyne method of reception can be used for receiving any ICW signals. The note received by straight detection will be distinctive of the type of modulation used in the transmitter, but when the autodyne or heterodyne method is used the received note will be mushy except in the case of the transmitter using the 500-cycle sinusoidal modulation, when the note will consist of chords, the predominant note having a frequency of 1,000.

The three-electrode vacuum tube as an oscillator.

31-327. (1) The action of a vacuum tube when generating oscillations is similar to the action of a clock. The pendulum of a clock swings back and forth and works the escapement. During each oscillation the escapement permits an impulse to be delivered to the pendulum in the direction in which the pendulum is swinging, tending to increase the amplitude of the swing. When the amplitude of oscillation of the pendulum increases to a certain value, the loss of power due to friction during each oscillation becomes equal to the power delivered to the pendulum by the im-

Analogy of oscillating tube and clock.

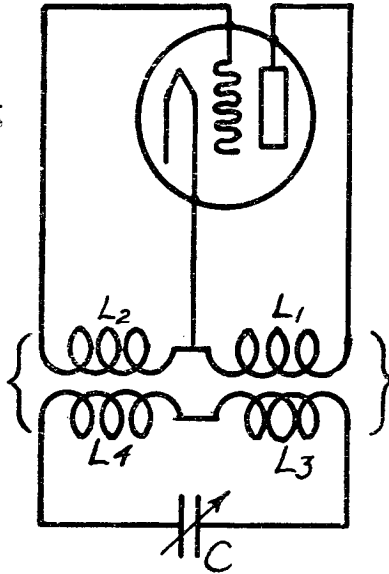

FIG. 31-14.—Diagram of Meissner circuit.

pulse, so that the oscillation no longer increases in amplitude but is maintained at a constant value.

(2) In the case of the three-electrode vacuum tube, the current in the oscillatory circuit is analogous to the swinging of the pendulum, the grid of the tube takes the place of the escapement of the clock and the plate battery replaces the main spring. The current in the oscillatory circuit acts upon the grid of the tube, changing its potential. The changes in potential of the grid produce changes in the plate current supplied by the plate battery, and these changes in plate battery current act upon the oscil-

latory circuit in the proper direction to tend to increase the current in that circuit. When the tube is put in operation, any feeble oscillation will build up in amplitude until a final amplitude is reached where the power supplied by the tube is equal to the loss of power in heat and radiation. The oscillations will then continue at this amplitude.

Typical oscillating vacuum tube circuit.

31-328. (1) A typical circuit for generating oscillations with vacuum tubes is the Meissner circuit. This is one of the earliest circuits, but is being employed to a considerable extent in modern transmitting tube apparatus. The circuit is shown in Figure 31-14, the filament and plate batteries being omitted for simplicity. The oscillatory circuit consists of the coils L_3 and L_4 and the condenser C . In transmission, the condenser C would be replaced by the antenna. The coil L_4 is included in the plate circuit of the tube and is coupled to the coil L_3 , while the coil L_2 is included in the grid circuit of the tube and is coupled to L_4 .

(2) Let it be assumed that feeble oscillations occur in the oscillatory circuit. These oscillations will induce an alternating voltage in coil L_2 which will act upon the grid, producing variations in the plate current flowing through L_1 , and these will produce an alternating voltage in the coil L_2 which, with the proper sign of coupling, will reinforce the original oscillations, causing them to increase in amplitude. The increased oscillations will induce a still greater voltage in the coil L_2 and correspondingly greater variations in the current through L_1 , leading to a further increase in the oscillatory current. This building-up process continues until the tube can not supply enough power to the oscillatory circuit to increase further the amplitude of the oscillations, and a constant alternating current will flow in the circuit having a frequency very nearly that of the natural period of the oscillatory circuit. Ordinarily the final state is reached in a very small fraction of a second after the tube is put into operation.

31-329. The alternating voltage on the grid of the tube produces the variations in the plate current when the tube is oscillating. The varying plate current can be considered to consist of two components, one a continuous current and the other a superimposed alternating current. It is the alternating component of the plate current which supplies the voltage to the oscillatory circuit and sustains the oscillations. The voltage which works the grid is derived from the oscillatory circuit. The plate current increases when the grid is positive, therefore, the required coupling between the circuits is evidently the following. When the alternating component of the plate current reaches its maximum value in the positive direction which makes the total plate current high, the current produced in the oscillatory circuit must be acting through the grid coupling so as to bring the grid voltage to its maximum positive value. Thus the alternating plate current and the grid voltage must be in phase. If the connections should be incorrect in the circuit a reversal of the connections to any one coil will usually make them right.

Phase requirements in oscillating tube circuits.

31-330. (1) In some cases, even when the circuit is such that the phase relations are correct, the tube will not generate oscillations. For example, a given tube will generate oscillations when the capacity in the oscillatory circuit is small but will not oscillate when the capacity is larger than a certain value. Also, increasing the resistance of the oscillatory circuit tends to stop the tube from generating oscillations, so that when the capacity is small the resistance can be higher and when the resistance is low a greater capacity can be used. When two tubes are put in parallel it is possible to get oscillations with more capacity or resistance than when only one tube is used.

Conditions for oscillation.

(2) In some cases at short waves the tube will refuse to oscillate at a low capacity value even when the connections are correct, or may even oscillate with a reversed connection from that which gives oscillations at higher capacity values. This is caused by incorrect phase relations between the grid voltage and plate

current resulting from the capacities of the coils, leads, and between the electrodes of the tube.

Adjustment for maximum output.

31-331. As pointed out before, the plate circuit of the tube supplies the power to the oscillatory circuit. This latter circuit acts as the load and, in fact, is very nearly equivalent to a resistance load in the plate circuit of the tube. In order to obtain the maximum current in the oscillatory circuit it is necessary that the load be of the proper value to fit the tube.

Use of coupled circuits.

31-332. Coupled tuned circuits are rarely used with vacuum tubes. The Meissner circuit does not come under this heading, because only one circuit is tuned. The objection is loss of efficiency and erratic operation. With close coupling between tuned circuits it is possible for oscillations of two different frequencies to occur. The vacuum tube can jump from one of these frequencies to the other; in fact, it is possible to adjust the circuits so that the antenna current is high and a definite wave length secured, and then find that, on keying, the current in the antenna will jump to a low value and widely different frequency.

Position of batteries or generators.

31-333. When an antenna is used with any of the direct coupled circuits the antenna ground is of necessity connected to some point on the tube circuit. It is desirable to connect the batteries or generators which supply the tube to the same grounded point in the circuit. The reason for this is that the batteries and generators have large capacities to ground, and unless the connections are made as indicated above these capacities to ground will be put in parallel with a part of the oscillatory circuit and will cause loss of power and possibly prevent oscillations. Ordinarily, therefore, the batteries or generators and the antenna ground are connected adjacent to the filament.

Efficiency of vacuum tube generator.

31-334. (1) The efficiency of a vacuum-tube generator is generally defined in terms of the input power supplied by the plate battery and the output radio-frequency power in the oscillatory circuit. The power required to heat the filament is usually neglected, though in small tubes it may be several times the output power. The power supplied by the plate battery is the product of the direct-current volts and direct-current amperes. The output power is the product of the square of the radio-frequency current times the resistance of the oscillatory circuit. The ratio

$$\frac{\text{output power}}{\text{input power}}$$

is the efficiency. For low-power tubes this may be 15 to 30 per cent; for medium-power tubes, 40 or 50 per cent. The maximum efficiency in high-power tubes is about 70 per cent.

Method of rating power.

(2) The Navy rates tubes in terms of the output power. For example, the CW 931 tube is rated as a 5-watt tube. It should therefore supply 1 ampere into a 5-ohm antenna, for 5 ohms times (1 ampere)² equals 5 watts. The normal plate supply is about 50 milliamperes at 350 volts, or 17.5 watts ($0.05 \times 350 = 17.5$).

The efficiency is then $\frac{5}{17.5} = 0.29$, or 29 per cent. Usually, efficiency is sacrificed to some extent in order to obtain the maximum output from the tubes: at reduced outputs somewhat greater

efficiencies are obtainable. The power in the plate circuit which is not used in generating oscillations is dissipated in heat in the plate of the tube. If the tube stops oscillating, then all of the plate circuit power is expended in heating the plate. In low-power tubes the plate of the tube can frequently be seen to heat up when oscillations stop. In high-power tubes this heating can be sufficient to destroy the tube in a short time, hence it is necessary to maintain oscillations or immediately shut off the tube.

31-335. The output of a tube is limited primarily by the total emission of electrons from the filament and the plate voltage, provided the design is such that the plates do not become overheated and the vacuum is high. With a given plate voltage, however, only a limited amount of emission from the filament can be used; the higher the plate voltage the more emission is useful. On the other hand, with a given emission the output of the tube can be increased without limit by increasing the plate voltage, provided the tube will stand it. Thus high plate voltages are necessary for high-power tubes. In tungsten filament tubes the filament emission is usually limited, for at usual operating temperatures it requires considerable filament power to supply the heat required to liberate the electrons. In the coated filament tubes the emission for the same filament power is very much greater—usually a number of times greater—than is normally utilized.

When the filament emission is very great the output current varies practically in proportion to the plate voltage, while with insufficient emission the output current is roughly proportional to the square root of the plate voltage.

31-336. (1) It is this strong dependence of the radio-frequency output current upon plate voltage which is utilized in the usual circuits for radio telephony. In radio telephony it is required that the amplitude of the radio-frequency current in the antenna shall vary up and down in accordance with the variations of current in the microphone. Thus in figure 31-15, if (a) represents the variations in the microphone current, the radio-frequency oscillations which are transmitted should vary in amplitude as shown in (b), where the envelope of the oscillations, shown by the dotted lines, is the same form of curve as the curve in (a). These oscillations are radiated by the antenna, and when received by a detector tube the current through the phones will duplicate the original microphone current and, hence, the speech will be duplicated. In the modulator-oscillator combination customarily used in telephone sets the microphone acts through a transformer upon the grid circuit of the modulator tube, as in figure 31-16, and varies its voltage in accordance with the speech vibrations. In the plate circuit of the modulator tube is a choke coil, L_a , of very high inductance for oscillations of speech frequencies. The variations in grid voltage tend to vary the plate current in the usual way, but these variations in plate current must flow through the choke coil which opposes the variations. On this account the voltage across the choke coil varies. With proper design these voltage variations can have an amplitude approximately equal to the plate voltage, so that on one

Variation of
output with plate
voltage.

Modulation of
the radio fre-
quency in output
in telephony.

swing of the grid voltage the total voltage acting in the plate circuit may be reduced nearly to zero and on the other swing may be nearly double that of plate voltage supply.

(2) The oscillator tube is fed from the same plate supply, and its plate circuit also includes the choke coil. When the micro-

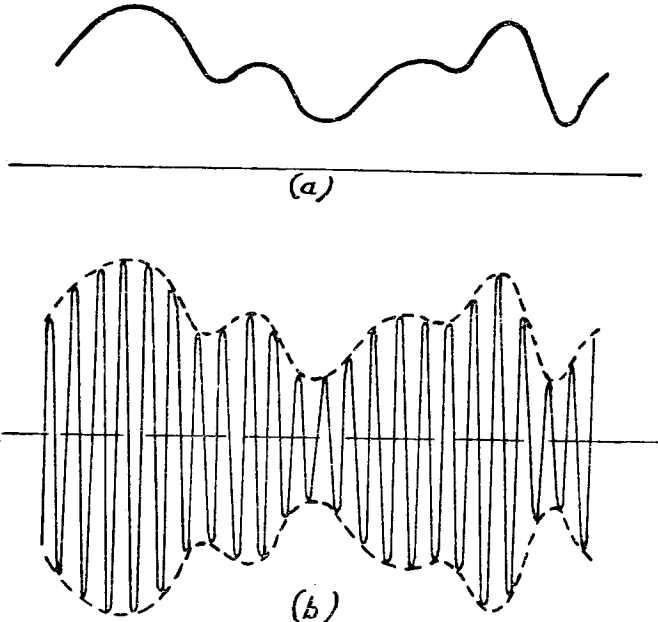

FIG. 31-15.—Radio-frequency oscillations modulated at audio frequencies.

phone is not being spoken into, the voltage on the plate of this tube is very nearly equal to that of the plate supply, since the direct current resistance of the choke coil is low. It will therefore generate radio-frequency oscillations having an amplitude

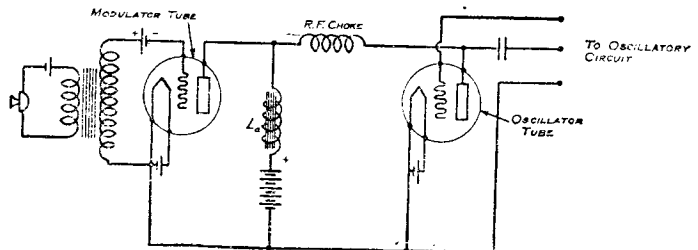

FIG. 31-16.—Connections of modulator-oscillator combination.

corresponding to this plate voltage. As soon as the microphone is spoken into, however, the plate voltage varies up and down, because of the action of the modulator tube and the amplitude of the radio-frequency oscillations varies accordingly. As stated before, this is the requirement for radiotelephony.

(3) In order that the best results may be obtained it is desirable that for speech of moderate intensity the amplitude of

the radio-frequency oscillations shall have a maximum variation from zero to double the amplitude corresponding to no speech. This is called complete modulation. The fluctuation of the radiation ammeter during speech is not a reliable indication as to whether good modulation is being attained or not.

(4) It is a natural mistake to attempt to modulate the output of an oscillating tube by applying the microphone voltages to the grid of the oscillating tube itself. It will be found, however, that in general the amplitude of the oscillations generated by a tube does not depend strongly upon the average value of the grid voltage. It is obvious, therefore, that this is a poor method of modulation.

31-337. The following vacuum-tube transmitters have been developed for use in the service:

Types of vacuum tube transmitter.

Name.	Power (watts).	Wavelengths (meters).	Type transmission.	Use.
TA.....	5	130 to 200.....	CW.....	Intra-fleet.
TB.....	5	292, 347, 365, 412, 492..	Telephone (duplex)	Fire control.
TC.....	150	405, 424, 476, 507, 538..	CW, ICW, telephone.	Battleships for aircraft spotting.
TD.....	1,500	507, 600, 800, 900, 975, 1,800, 2,750.do.....	Aircraft base station.
TE.....	300	507, 600, 675, 800, 975, with flat top antenna, 675, 975, with loop.do.....	Submarines.
TF.....	300	507, 600, 675, 975, 1,080, 1,260, 1,450.do.....	Scout cruisers, submarine tenders and aircraft tenders.
TG.....	300	507, 600, 675, 800, 975.do.....	Eagle boats.
CW 936..	5	236-345.....	Telephone.....	Destroyers, submarines and Eagle boats.
SE 1345..	5	405, 424 476, 507, 538.	CW, ICW, telephone.	Aircraft.
SE 1370..	50	507, 600, 800, 975.....do.....	Do.
SE 1390..	150	507, 600, 800, 975.....	CW, ICW.....	Aircraft (NC boats).

31-338. The model TB (telephone) and the model TC (telephone-telegraph) will be selected as typical of the existing Navy vacuum tube sets, a brief general description of the Model TB set and a more detailed description of the Model TC set being given in the following articles.

Typical transmitters.

(B) THE MODEL TB RADIO TELEPHONE EQUIPMENT.

PART 1.—GENERAL.

General.

31-339. The model TB radio telephone equipment is intended to provide telephone communication between units of the fleet and to perform this service in such a way that the calling and carrying on of a conversation is practically identical with ordinary commercial telephone practice. Simultaneous two-way conversations can be conducted without the necessity of operating any switch when changing from transmitting to receiving, or vice versa. Extension lines and stations are provided at different points on board ship so that it will not be necessary to carry on the conversation at the radio set. The transmitter and the receiver constitute the central station and are under the control of a radio operator, who also operates the apparatus necessary for routing the outgoing or incoming conversations of any of the extension stations.

PART 2.—DESCRIPTION.

- ↓
- Duplex feature.** 31-340. Simultaneous two-way operation is obtained with the use of only one antenna for transmitting and receiving. In addition, the circuit is so arranged that the talker can hear what he is saying and can interrupt the party with whom he is talking, or be interrupted by him in the same manner as in the ordinary telephone. (This necessitates a combination of transmitter and receiver on the same antenna, so arranged that the large current in the antenna caused by the talking will not interfere with the operation of the receiver which is designed to receive small currents. This calls for a complete shielding of the receiver from the transmitter)
- Shielding arrangement.** 31-341. (1) A differential method is used for shielding purposes. (The current from the transmitter is taken to a central point of the winding of an inductance coil, at which it divides equally, half flowing through one section of the coil into the antenna and the other half flowing through the other section of the coil into the balancer. By careful adjustment of the balancer the two currents can be made so closely alike in magnitude and in phase that the magnetic fields of the two halves of the coil are balanced, and, therefore, produce no effect on a third coil suitably placed in the neighborhood.)
- Coupling.** (2) The secondary tuning coil of the receiver is located within this coil and is arranged so that the coupling between them can be varied. The secondary tuned circuit is thus, in virtue of the balancing just described, sensitive to any incoming currents received by the antenna as these pass through both halves of the branching coil in the same direction and thereby set up an external magnetic field.
- Constants of balancer unit.** 31-342. In order that the balance may be less susceptible to disturbance from frequency variations, the balancer unit is so designed that, after proper adjustment, it duplicates approximately the antenna characteristics over a wide range of frequencies. This makes it unnecessary to readjust the balance whenever the transmitting wave length is changed.
- Circuit arrangement.** 31-343. The schematic arrangement is shown in figures 31-17 and 31-18. From figure 31-18 it will be seen that the circuit is virtually a Wheatstone bridge circuit with the transmitter and the receiver located in conjugate arms so that electromotive forces generated in the transmitter arm do not produce any currents in the receiver circuit. In the sketches are shown two condensers, C_3 and C_7 , one in series with the antenna and the other in series with the balancer. These condensers reduce the effective capacity of each circuit and at the same time render the balance of the system less sensitive to small changes in the electrical constants of the antenna.

PART 3.—VACUUM TUBES.

- Plate voltage.** 31-344. (1) The CW 931 coated filament vacuum tubes used in the model TB set are made to operate on a plate voltage of approximately 350 volts when used for transmitting purposes.
- ↓

When used in a receiver circuit, they will operate satisfactorily on a plate voltage of 40 volts or over.

(2) The normal filament current is 1.30 amperes, which is enough to insure a very copious emission from the filament under all conditions of plate and grid voltage.

31-345. (1) The filament current is the most important factor determining the life of the tube, a relatively small increase being

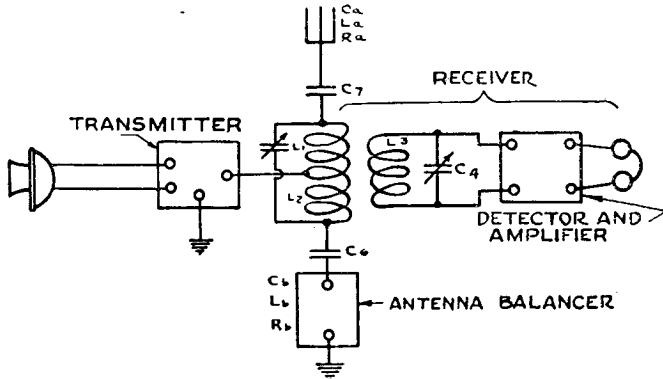

FIG. 31-17.—Diagram of TB telephone equipment circuit.

enough to cut the life down to a small fraction. With a filament current of 1.30 amperes an average life of about 300 hours may be expected, for 1.25 amperes the average life would probably exceed

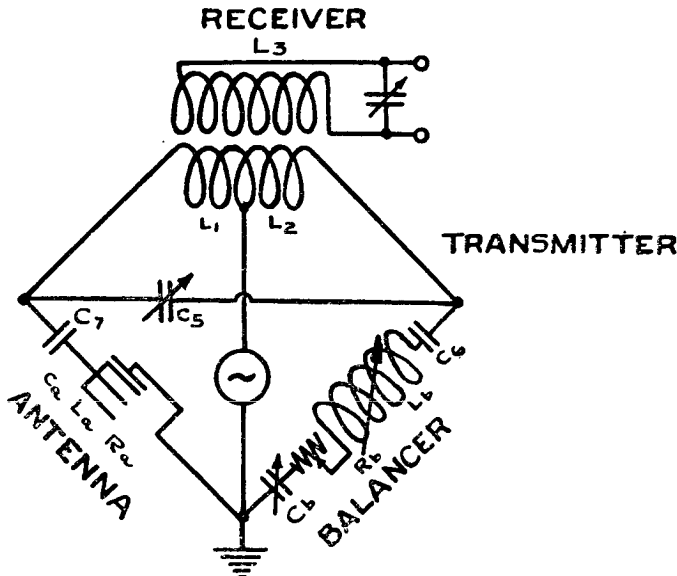

FIG. 31-18.—Wheatstone bridge arrangement of TB telephone equipment circuit.

1,000 hours, while for 1.35 amperes the tube would last probably less than 100 hours.

- Effect of filament current on output.** (2) In most cases it will be found that the output of an oscillator is not much increased by raising the filament current above 1.25 amperes and in many cases the full output will occur with even lower filament currents. Generally the filament current should not be increased above that necessary to give the full output and in no case should it be increased beyond 1.35 amperes.
- Plate current.** 31-346. The plate current should not be allowed to exceed 50 milliamperes in any tube and for the most satisfactory working should be from 35 to 40 milliamperes.
- Tube failures.** 31-347. (1) Aside from purely mechanical causes such as breaking of the filament or of the lead-in wires some of the principal causes of failure are as follows:
- Presence of gas in the tube.** (2) As a result of abnormal heating of the tube, due usually to an overload, it may happen that a small quantity of gas is driven out of the metal or glass into the bulb. The presence of this very minute quantity of gas causes the bulb to be filled wholly or partly with a blue haze when the filament is lighted and the plate voltage applied. The plate current is increased and the plate may become red hot. If the voltages are not cut off an arc may form in a short time between the filament and the grid or plate resulting in the burning out of the tube.
- Bright spots on filament.** (3) After a tube has been in use for a long time it may be noticed that the filament is not uniformly bright but has one or more points that appear to be brighter than the remainder. While the presence of the bright spots does not affect the operation of the tubes the presence of these bright spots indicate that the filament is approaching the end of its life and may shortly burn out. "Bright spots" occur frequently in the coated type of filament but rarely in the tungsten filament.
- Reformation of filament or grid.** (4) If the tube has been subject to an abnormal stress there may result a bending of the filament or grid great enough to result in their coming into electrical contact. Such a condition can usually be detected by the eye.
- Electrolysis of the glass.** (5) If power tubes, the lead-in wires of which are carried through a common stem and seal, are operated considerably above their rated plate voltage, electrolytic action in the glass of the seal will take place between the plate and grid. This electrolysis in the course of time will run the seal, making it leak air and sometimes even crack it. An indication of this electrolysis, which appears long before leakage occurs, is a blackening of the grid leads in the glass of the seal near the vacuum end.

PART 4.—FAULTS AND REMEDIES.

31-348. Sufficient information is not at hand at the present time to give a full list of faults and their remedies peculiar to this equipment. However, the usual faults that may arise in vacuum tube apparatus are likely to be encountered in this set. The receiving equipment exclusive of the part that is common to the transmitter can be cared for in the same manner as for any of the other receivers, detectors and audio-frequency amplifiers now in service use. If the instruction pamphlet that comes with each equipment be carefully studied before it is attempted to

operate the equipment, it will be found that the faults that will develop in the use of the apparatus will be due to the apparatus itself, and not to inexperience on the part of the operator.

(C) THE MODEL TC RADIO EQUIPMENT.

PART 1.—GENERAL.

31-349. The model TC radio equipment includes all of the apparatus necessary for transmitting and receiving with the exception of the antenna. The transmitter is provided for the three types of transmission, namely, CW, ICW (buzzer modulated) and telephone, and is relatively high powered. It is designed for battleship use to communicate with spotting planes and other vessels. The absolutely reliable range for spotting work, using CW transmission, is 50 miles; 10 to 15 miles for ICW, and 5 miles for telephone transmission. These ranges will probably be increased when more experience has been gained in the use of the apparatus.

Purpose.

PART 2.—THEORY.

31-350. Two requirements must be fulfilled in a radiotelephone and continuous-wave telegraph transmitter:

Requirements.

(1) There must be provided a source of radio-frequency energy.

(2) There must be provided means of modulating or controlling the radio-frequency energy in accordance with the method of transmission employed.

31-351. The source of the radio-frequency energy is the vacuum tube which acts as a converter, changing the high voltage direct current to a radio-frequency current. In this set three tubes (type CG 1144A or CW 1818) are employed in this capacity and are known as oscillator tubes. The oscillator consists of four fundamental circuits:

The oscillator.

- (1) Antenna.
- (2) Plate.
- (3) Grid.
- (4) Filament.

31-352. Upon closing the switches an instantaneous surge occurs in the plate circuit with the result that the antenna is forced into feeble oscillations whose period depends upon the inductance and capacity of the antenna circuit. The grid circuit due to its inductive relation to the antenna withdraws some of this oscillating energy with the result that an oscillating potential is applied between the grid and the filament. This produces a change in the plate circuit which, if the circuits are properly arranged, adds to the effect of the original surge. This cycle of operation is then repeated with the antenna current continually increasing until limited by the antenna and tube characteristics. Figure 31-19 is a simplified sketch of the TC transmitting set.

Maintenance of oscillating condition.

31-353. In order to telegraph using continuous waves, means are provided whereby the operation of the telegraph key starts and stops the generation of radio-frequency energy. This is accomplished by opening and closing the short circuit around the keying condenser. When the keying condenser is short-

Continuous-wave telegraph transmission.

ly the circuit and tube characteristics. These amplified variations are in turn impressed upon the modulator grids by means of capacitive coupling. The variations of modulator grid potential produce corresponding variations in the plate current and tube impedance. These variations in the modulator plate circuit result in a corresponding increase or decrease of the power available for the plate circuit of the oscillator. This action is due to the fact that there is practically a constant current supply for the plate circuit of both the modulator and oscillator tubes due to the iron core reactor in the positive side of the plate generator.

31-358. For buzzer modulation, the operation is practically the same as in telephony except that the microphone transmitter is replaced by a buzzer. When the signal switch is set on "Buz" the buzzer operates whenever the telegraph key is depressed. The oscillations are started and stopped as in continuous wave telegraphy. Side tone is provided on both the telephone and buzzer modulated method of communication. ICW transmission.

PART 3.—DESCRIPTION.

31-359. (1) The transmitter, type CG 1322, uses six vacuum tubes, type CG 1144A or CW 1818, three of which are employed as oscillators, two as modulators, and one as a voice amplifier. The output of the transmitter is, therefore, that of the three oscillator tubes for CW transmission, and in excess of this for ICW and telephone transmission. Transmitter.

(2) The coil system is composed of two units, the antenna coil being mounted with the plate and grid coils as one unit and the variometer and loading coil forming the other unit.

(3) The transmitter is arranged to transmit on low, medium, and high power. The Meissner circuit is used; consequently, the constants of the antenna circuit alone determine the wave length of the transmitter. All the controls for the transmitter including the wave change switch, signal switch, power switch, and antenna variometer, are manipulated by knobs on the front of the transmitter panel. A wave length indicator is provided for operation only on low power, and has an incandescent bulb which will light when the transmitted wave is in resonance with the wavemeter. The wavemeter is adjusted to five fixed wave lengths. The changing of the wavemeter setting is effected by means of the wave change switch. Powers available.

31-360. The receiver, type CG 1323, is a separate unit and contains the usual type of receiving circuits. It has, in addition, two stages of audio-frequency amplification and a switch for changing the telephones to detector plus one stage of audio-frequency amplification, or to detector plus two stages of audio-frequency amplification. The type CG 933 vacuum tube is used as the detector for both detection and amplification purposes. The receiver is shielded in the usual manner to prevent electrostatic coupling between the antenna and secondary circuits. The receiver.

31-361. The interphone unit, type CG 1324, has the following controls and indicators: The interphone unit.

Five 3-way station keys.

One 3-way operator's key.

Five telephone switchboard lamps.

Two push buttons.

One buzzer switch.

The power unit. 31-362. The power unit assembly, type CG 1328, consists of the following units, which are connected together by flexible couplings:

- (1) One 1,000-volt direct-current generator excited from line supply.
- (2) One 24-volt direct-current generator excited from line supply.
- (3) One 125-volt or 240-volt direct-current motor.

PART 4.—OPERATION.

General. 31-363. The following instructions are complete for operation on one method of communication and on one wave length. To transmit on any of the other wave lengths or by the other methods of communication it is only necessary to place in position the switches so designated and proceed in the same manner as outlined below:

Necessary steps for transmission.

(1) To transmit—

(a) Lamp used as voltage indicator should be lighted. This indicates that supply voltage is available.

(b) Close line switch.

(c) Close "Control transfer switch" to position No. 1. Connects "Starting equipment No. 1" and "Relays No. 1" in circuit.

(d) Close "Machine transfer switch" to position No. 1 and push operator's key to "Radio." Connects "Machine unit No. 1" in circuit.

(e) Push "Start motor" push button. Starts "Machine unit No. 1" using "Starting equipment No. 1."

(f) Throw "Power switch" to desired power. Place "Monitor key" on "Radio." Place "Signal switch" on "Tel." Operate "Push to transmit" button in interphone unit.

Filaments light.

"Relays No. 1" operate.

Plate voltmeter indicates.

Plate ammeter indicates.

Filament voltmeter indicates.

(g) Adjust "24-volt field rheostat" until filament voltage is not over 21 volts.

(h) Adjust "High-voltage field rheostat" until meter reads 1,000 volts.

(i) To tune transmitter to one of the designated wave lengths, first set power switch on "Low" then press wave indicator push button and adjust antenna variometer until indicator lamp shows maximum brilliancy.

The plate and grid adjustments should be made with the power switch set on Low and signal switch on CW. The approximate

plate and grid coil settings for the particular wave length should be obtained from the following tabulation :

Wave length.	Plate tap.	Grid tap.
405	5	6
424	5	7
476	7	8
507	7	9
538	8	10

The antenna current should be noted under this condition. The plate coil taps should then be changed, one or two taps on either side of the normal settings and the grid coil tap and coupling adjusted so that maximum antenna current is obtained with minimum plate current. After the above adjustment has been made, turn power switch to High position and note plate current. Do not exceed a plate current of 0.45 ampere when operating on CW. When signal switch is in Buzzer position the plate current should not exceed 0.9 ampere when key is depressed. It may be found that some plate and grid taps will give slightly more output than others, with plate current in excess of 0.45 ampere. Such operation is undesirable since the tubes are under more severe service, and the increased output is made at the sacrifice of efficiency. The antenna current should be noted in each case and the plate and grid tap used that gives maximum output. This process should be repeated for all wave lengths. That position of the grid coil should be used that gives the best average results on all wave lengths. Once the settings are obtained, it will be unnecessary to change them unless the antenna characteristics are changed considerably. The reason for this is that the wave change switch automatically changes the loading coil tap, the plate tap, and the grid tap.

See that the machine unit is not operating before changing any tap or, in fact, touching any of the apparatus inside of the cabinet proper.

(j) Transmitter is now ready for transmission on the particular wave length and method of communication and power designated.

(2) To receive—

(a) Turn "Filament rheostat" in direction of arrow. Adjust filament light to proper brilliancy. Steps necessary to receive.

(b) Set "Amplification control switch" on "Max."

(c) Set "Amplification key" on "Second stage."

(d) Tune in the signals desired.

(e) To decrease amplitude of signals turn "Amplification switch" away from "Max." or cut out stages of amplification by means of "Amplification key."

(f) To shut down receiver, turn "Filament rheostat" to "Off."

(g) For the reception of telephone communication, it will be found that clearest speech can be received with the tickler coil set to give maximum regeneration. While telephone conversation can be received with the receiver oscillating, it will be found, in general, that the regenerative position is better.

31-364. To establish radio communication from an extension station:

(1) Lift up receiver at station No. 1. This lights line lamp on interphone unit, thus notifying the operator that a station is calling.

(2) When a line lamp lights, the operator throws the key corresponding to the calling station into the interphone position and the operator's key to normal. This permits communication between the calling station and the operator.

Establishment of communication with extension station. (3) After notifying the operator regarding the details of the desired radio connection the receiver should be replaced on the hook. The operator will call the extension station when the radio connection is established.

(4) Operator establishes radio connection as described on the preceding page.

(5) Operator places key of calling station into the interphone position and his own key to normal and pushes the button designated "Ring."

(6) Operator throws station key into "Radio" position, thus transferring control of the radio equipment to the extension station. Operator's "Push to transmit" button must not be depressed when an extension key is thrown to "Radio" as this would prevent control from the extension station. Operator's key should be placed in "Monitor" position whenever an extension station key is thrown to "Radio."

(7) The party at the extension station depresses button in column of desk set when he talks and releases it when he receives.

(8) When the conversion is ended, the extension receiver is replaced on the hook and line lamp lights, indicating to operator that party at extension station has finished.

(9) Operator returns "Signal" switch on transmitter to "Off" position, station key to normal position, and operator's key to "Radio."

(10) Operator is now in position to control set.

PART 5.—FAULTS AND REMEDIES.

31-365. The following faults and their causes are given. The remedies are obvious:

Failure to oscillate. 31-366. Failure to obtain oscillations may be due to:

- (1) Plate circuit open.
- (2) Improper adjustments.
- (3) Poor tubes.
- (4) Filament current low.
- (5) Open antenna circuit.
- (6) Grounded antenna.
- (7) Leaky insulators.
- (8) Antenna ammeter burned out.
- (9) Trouble in power unit.
- (10) Arms on wave-changing switch not making proper contact.

Failure to modulate. 31-367. Failure of modulating circuit to function may be caused by:

- (1) Modulator plate circuit open.
- (2) Defective microphone transformer or microphone transmitter.
- (3) Poor biasing batteries.
- (4) Poor modulator or amplifier tubes.
- (5) Resistance or reactance open in modulation amplifier circuit.

31-368. Causes of failure to receive are:

- (1) Improper tuning adjustments.
- (2) Filament current low.
- (3) Defective plate batteries.
- (4) Poor tubes.
- (5) Open or grounded antenna circuit.

Failure to receive.

31-369. Most of the accidents to personnel and material will be avoided by a strict observance of the following "Don'ts" when operating the transmitter:

- (1) Don't touch any apparatus inside cabinet when motor-generator is running.
- (2) Don't operate set unless all external connections have been made. Be sure of polarities. Don't fail to check polarity after replacing grid or C battery before using set.
- (3) Don't allow plate voltage to exceed 1,000 volts.
- (4) Don't allow plate current to exceed 0.450 ampere when testing on CW or 0.9 ampere when testing on buzzer, key locked.
- (5) Don't operate set with filament voltage less than 20 or more than 21 volts.
- (6) Don't operate set unless antenna ammeter indicates.
- (7) Don't make transmitter adjustments with power switch on "high"; set the switch on "low."
- (8) Don't adjust plate and grid taps with the machine unit in operation.
- (9) Don't forget that fuses are cheaper than vacuum tubes; therefore do not use substitutes for the plate fuses furnished with the set.
- (10) Don't change position of "wave change" switch unless "signal" switch is in "off" position.
- (11) Don't change position of "wave change" switch unless proper plate and grid adjustments have been made.
- (12) Don't work inside of cabinet with metal tools unless machine unit is shut down and batteries are disconnected from set.
- (13) Don't leave keys in interphone unit in operating position when this unit is not in use.
- (14) Don't adjust back coupling coil so that oscillations occur in receiver when telephoning.
- (15) Don't leave apparatus when a radio conversation is taking place. Monitor on the connection so that you can take care of emergencies.

(D.) TRANSMITTING VACUUM TUBES.

PART 1.—GENERAL.

General.

31-370. The following table lists all the transmitting vacuum tubes now in use in the service. Opposite the type number of each tube is given the maximum allowable filament and plate voltage and current when the tube is used as an oscillator. It will generally be found, however, that less filament current than the value given in the table can be used for normal operation.

Life of vacuum tube.

31-371. The life of a transmitting tube, provided the vacuum remains good, is directly dependent upon the life of the filament. The emission of the type CW vacuum tubes (coated filament) is greatly in excess of the amount that can be utilized at the maximum plate voltage, as given in the table, consequently this type of tube should be operated as far below the maximum as possible and the life of the tube thereby lengthened. In the case of the type CG tubes (tungsten filament), the filament current has an extremely important bearing on the life of the tube. A *very* small increase of filament current over the maximum value will result in a very marked decrease in the life of the filament. On the other hand, the total emission from this type of filament is not greatly in excess of the amount utilized at the specified plate voltage. It is, therefore, well to operate these tubes at or below the value given in the table for the particular tube and *never to exceed* the maximum value.

Type No.	Watts output (nominal rating).	Filament.		Plate.	
		Volts.	Amperes.	Volts.	Milli-amps.
CW 931.....	5	7.0	1.35	350	50
CW 1818.....	50	8.7-10.0	3.4	750	150
CW 1819.....	250	12.5-14	6.25	1,500	150
CG 1162.....	5	7.5	1.75	350	50
CG 1144A.....	50	10.0	6.5	1,000	150
CG 916.....	250	18.0	3.6	1,500	150

SECTION V.—AIRCRAFT RADIO EQUIPMENT.

PART 1.—GENERAL.

Purpose.

31-400. Aircraft are equipped with radio apparatus for establishing the following lines of communication:

- (1) Aircraft to aircraft.
- (2) Aircraft to ship.
- (3) Aircraft to shore.

If the aircraft is equipped with only transmitting apparatus, the above communication by radio is one-way. However, when the aircraft is equipped with receiving as well as transmitting apparatus, the communication is both ways.

Special requirements.

31-401. All the classes of transmitters and receivers used for ship and shore work are applicable to aircraft duty, but for this duty the apparatus is specially constructed as regards weight and ruggedness.

31-402. The transmitting apparatus includes the following **Classes of transmitters.** classes:

- (1) Spark—
 - (a) Synchronous.
 - (b) Quenched.
 - (c) Chaffee.
- (2) Vacuum tube—
 - (a) Interrupted continuous wave.
 - (b) Telephone.
 - (c) Continuous wave.

31-403. The order of efficiency of transmission for the above **Efficiency** classes of transmitters is spark, ICW, telephone, and CW, the spark being the least efficient. In point of difficulty of being received, the order is reversed, CW signals being the most difficult to pick up. The highest powered transmitters at present in use are of the spark class, while the longest range transmitters are probably of the continuous-wave class. On the other hand, it is considered that more reliable communication is obtained with transmitters of the spark class. This is mainly due to the fact that spark signals are more easily picked up than to any inherent weakness of the vacuum-tube transmitters. Interference is least with continuous-wave transmission and greatest with spark. For this reason it is proposed to use continuous-wave transmitters for spotting planes where a large number of planes are required to operate simultaneously and within a narrow band of wave lengths.

31-404. The power plant for aircraft radio transmitters is **Source of power.** now being standardized to use the fan-driven set equipped with a self-regulating fan (constant speed and power). For some time to come, however, there will be a considerable number of spark transmitters operated by nonregulating fans, and of vacuum tube transmitters operated by storage batteries.

31-405. The latest types of radio apparatus for aircraft will give as reliable communication as any ship or shore station radio apparatus of equal power. However, aircraft radio apparatus **Reliability.** requires far more care and attention than ship radio apparatus for many obvious reasons, some of which are that the apparatus must be constructed with much less weight and, therefore, must be handled more carefully. For example, the weight of a one-half kilowatt transmitter for aircraft service is approximately 60 pounds, while one of the same type and power for ship service weighs in the neighborhood of 400 pounds, both weights being exclusive of the antenna equipment. Also, aircraft radio apparatus (in direct contrast to ship radio apparatus) is exposed to the most severe weather conditions, operates under terrific vibration, is constantly exposed to the most severe shocks in landing, etc., and is subjected to temperature changes varying from below zero to over 100° above zero. For these reasons the utmost care should be taken in the installation, handling and upkeep of the apparatus. Canvas covers are provided to protect the apparatus when not in actual use. It is estimated that 75 per cent of the failures of aircraft radio apparatus to function properly are due to the improper installation and upkeep of the equipment. When

this condition is eliminated, the aircraft equipment can be classed with ship and shore station equipment in the matter of dependability.

31-406. Aircraft radio equipment is, in general, similar in theory, operation, care and upkeep to the equipment found in ship and shore station installations, therefore, the operation of apparatus typical of each class and pertinent only to aircraft installations will be given here.

(A) RADIO TRANSMITTERS.

PART 1. SYNCHRONOUS SPARK TYPE.

Description. 31-407. Type SE 1300 and SE 1310 aircraft transmitters are of the synchronous spark type. These transmitters are provided with a toothed wheel keyed to the alternator armature shaft and so placed that one spark will occur between the toothed wheel and fixed electrode at the instant that the alternating voltage in the generator reaches its maximum positive or negative amplitude, thus causing one spark per alternation.

Operation. 31-408. These sets should *always* be given a bench test before installation and after long periods of idleness in order to make sure of proper generation, insulation and setting of spark gap. The wave length must be adjusted and set before flight except in the later modifications of the sets, where three wave lengths are provided. In the modified types, any one of the three wave lengths provided can be selected by a remote control of the generator unit wave changer from the operator's position. The antenna circuit is tuned to resonance with the closed oscillating circuit (set to the proper wave length before flight) by means of a variometer in the antenna circuit. The use of the variometer compensates for different lengths of antenna. The antenna circuit is in resonance when maximum radiation is obtained. This tuning is usually done by varying the inductance in the variometer until resonance is obtained.

PART 2.—QUENCHED-SPARK AND CHAFFEE GAP TYPES.

General. 31-409. Transmitters using the quenched-spark gap and the Chaffee gap are similar in operation. The type SE 1320 transmitter employs the Chaffee gap.

The Chaffee gap transmitter. 31-410. The Chaffee gap transmitter is of the so-called impact type. Unlike other types of spark transmitters, the antenna circuit can be tuned to the desired wave length without making any adjustment of the closed oscillatory circuit and not suffer from a great loss in efficiency. For this reason it is very flexible and will operate on antennas of widely different constants. It has only one wave length, but this wave can be changed somewhat by varying the length of the antenna, although best efficiency will be obtained on the wave length for which the set is designed.

Operation. 31-411. The operation of this set is very simple. The antenna is let out to its proper length. The spark gaps are both closed, the transmitting key depressed and the gaps adjusted until maximum radiation is obtained. The set is then ready for use. The

generator is wind-driven and very reliable, but the generator field must be separately excited momentarily by means of a small dry battery which is supplied for that purpose. The complete transmitter should always be subjected to a bench test before installation and after periods of idleness.

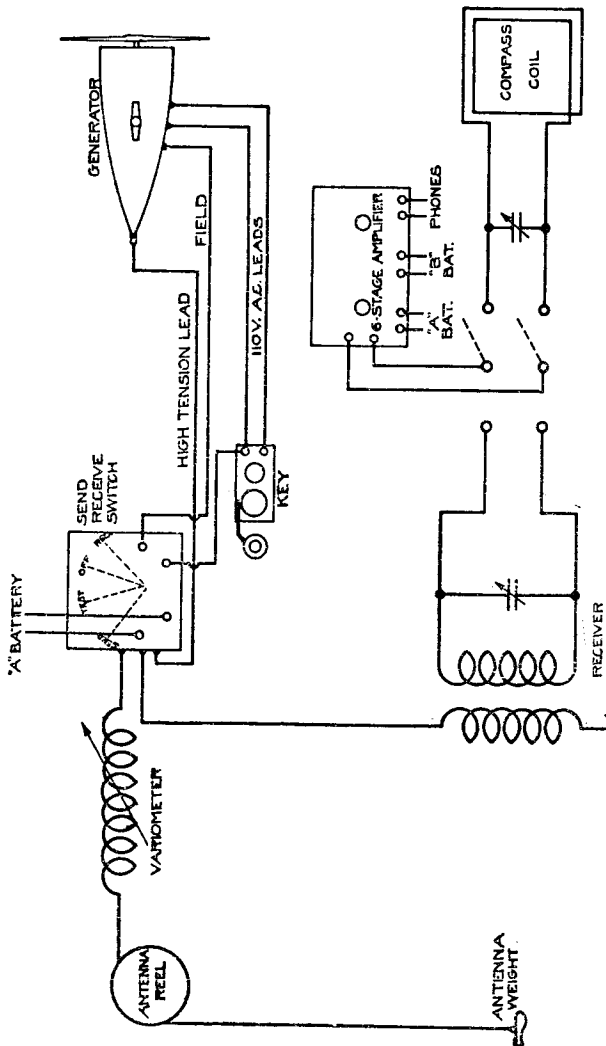

Fig. 31-20.—Standard installation of transmitter, type SE 1310 on the F-5-L.

31-412. Figure 31-20 show a simplified diagram of a standard installation of the type SE 1310 transmitter on the F-5-L. The use of a separate dry cell for exciting the field of the generator is obviated by connecting the vacuum tube filament battery to the "Send-receive" switch, so that when the handle of the switch passes over to the "send" position it momentarily touches the "test" position, throwing the battery across the field of the generator and in this way causing the generator to pick up. Details of

Installation on
"F-5-L's."

this switch are not shown in the diagram. The switch has four positions; these are "send," "off," "test," and "receive." Great care must be taken in wiring up the switch and variometer to have the variometer between the switch and antenna, otherwise the switch will be at a high potential, which will result in dangerous arcing, especially when these transmitters are fitted with the wave-changer switch, giving 507, 600, and 800 meters. This wave-changer switch is mounted with its handle on the outside of the generator streamlined body. The best place to mount the generator on an F-5-L is on the center rear strut, where the operator can reach the switch from the after cockpit opening while the plane is in flight. Frequently the type SE 1414 receiver is installed with this transmitter instead of the standard type SE 1950 receiver with amplifier. In this case the vacuum tube filament battery should be connected to a D.P.D.T. switch for throwing it alternately to the receiver or to the proper connections on the transmitter switch for exciting the generator field. This must be done because of a peculiarity in the single circuit type SE 1414 receiver.

PART 3.—VACUUM-TUBE TYPE.

General.

31-413. Many types of tubes and tube transmitters are being used in naval aviation. They all operate on the same general principle, but some accomplish their functions more efficiently than others. The tube transmitter has the advantage of much lower decrement, thus causing less interference. Three methods of transmission are possible with a vacuum-tube transmitter. These are (1) ICW., (2) telephone, (3) CW. The telephone feature can be used to advantage in many cases, but is not as reliable or efficient as the other two methods. The buzzer modulated, or in later sets, the chopped continuous wave is more efficient and will carry through strays or interference better than the telephone. The continuous wave will give a greatly increased range, but unfortunately it is much harder for the receiving station to tune in; therefore, unless the receiving station is specially instructed to listen for that exact wave and to use the continuous-wave method of reception, the signals will not be heard.

Operation.

31-414. (1) The later types of tube transmitters operate from a wind-driven generator using the self-regulating propeller, which gives a very constant generator speed, thus maintaining a constant voltage which is so necessary to the proper operation of tubes. This generator provides the filament or "A" current and the plate or "B" current. The grid or "C" voltage is supplied from a dry battery. Care should be exercised in handling the plate current as this is high voltage. As these sets usually have provision for three methods of transmission, the switch must be set to operate on the method desired. The sets are also designed to operate on several wave lengths. To operate it is necessary to set the wave changer switch on the wave length desired and to throw the transmitter switch to "Transmit" position. Tubes should immediately light up. Take note of meters and adjust each circuit to show proper reading as given in instruc-

tions. Some tube transmitters are provided with a lamp in the plate circuit to indicate whether the set is modulating properly or not. This lamp should show a cherry red glow when not sending or talking and, if set is functioning properly, it should light up considerably brighter when talking, or if using buzzer modulation, when the key circuit is closed. The best modulation is obtained when the greatest variation in brilliancy is noted on the modulation indicator lamp. When continuous wave transmission is being used, this lamp is not lighted.

(2) All types of tube transmitters now in use employ special tubes as modulator tubes which are not used in the continuous wave transmission. Later types will probably be so designed as to use all the tubes for all methods of transmission. On battery powered tube transmitters care should be taken to adjust the filament current very carefully, as upon this one adjustment depends in a great measure the proper operation and life of the tube. Obviously, an adjustment made in the filament current at the start of a flight will not hold good during the entire flight, as the battery voltage decreases rapidly during operation. Therefore, to counteract this, the resistance in the filament rheostat must be reduced to make up for this drop in voltage.

31-415. When the radio equipment is installed on planes at the factory or at naval aircraft stations, the entire equipment should be carefully tested before the planes are shipped from the factory or flown. This can be done by providing a separate portable motor to drive the generator and a dummy antenna, consisting of a capacity, inductance, and resistance. The constants of the dummy antenna should be the same as those of the service antenna. By this means the transmitter can be tested before flight and tuned approximately to the desired wave length, thus obviating the possibility of failure of the transmitter during flight, due to faults in the connections and apparatus. Installation and testing.

31-416. It is especially important that every part of the installation be carefully gone over before each flight, special care being taken to see that all connections are tight, covers removed from the apparatus, that the batteries have just come off charge and are in good condition, that the filaments of the vacuum tubes for the detector and amplifier light up, that the interphone is working satisfactorily, that no part of the apparatus equipped with the cradle suspension is touching the body of the plane, that the list of spares is complete, and, finally, that the emergency communication equipment is complete in every detail and ready for instant use. Tests preparatory to flight.

31-417. (1) A few of the troubles which are most frequently experienced will be enumerated. It should be remembered that it is impossible to conduct much repair work during flight, hence a very careful test to determine positive operation should be made just before flight. Examine switch contacts to rear of the panel for loose contacts. Make a careful examination of the wiring to see if any circuits are open. Examine the tube base contacts and all outside connections to the battery, generator, antenna, etc. If trouble is being experienced and can not be immediately located, substitute new tubes and try again to oper- Faults and remedies.

ate. If trouble is not then apparent it is probably due to generator faults, open grid leak, or a short-circuited condenser, neither of which can ordinarily be repaired in flight.

Peculiarities of continuous-wave transmission.

(2) Operation of tube transmitters on short wave lengths by the continuous wave methods entails very careful work on the part of the receiving operator, but insures great freedom from interference and great range. It also requires special care on the part of the operator in the plane. It is very well known that a very small alteration in the wave length when receiving continuous waves below 1,000 meters will cause the beat note in the receiver to change its pitch to so great an extent that it may pass beyond the limits of audibility and thus the signal will be lost. The standard spotting plane set, type SE 1345, now being modified for continuous wave transmission, has the peculiarity that when the plane is making an abrupt turn, the configuration of the antenna with respect to the plane changes, thus altering its capacity and making a slight difference in the wave. This makes trouble for the receiving operator during reception. Therefore, the pilot should not transmit important information when making a quick turn.

Directional effect and fading of signals.

(3) All transmitters using wave lengths relatively short compared with the antenna length, which is especially true of spotting plane sets with 140 feet of antenna, show some directional effect, that is, the signal is stronger when the plane is flying towards the receiving station than when the plane is flying away from it. This effect becomes less pronounced when the plane gets farther away. It is, therefore, not very serious. When the plane is flying directly over the receiving station, however, a great many curious directional effects are observed, the signal fading out entirely during brief intervals in spite of the nearness of the transmitter. It is assumed that small, fast planes capable of making quick turns will only do this in case they are in actual combat, in which case they will usually find it necessary to cut away the antenna altogether in order to make quick evolutions. If such planes are on spotting duty they should fly over the course laid out for them, the line of flight making a figure 8, with slow turns at each end, and if it is for any reason necessary to make a quick turn, spotting signals should not be sent until the plane is at least partially turned about. If the plane is not very distant, say within ten miles, it will be better to fly around the figure 8, so that all turns are made towards the ship receiving, so that taking the directional effect into consideration the ship will always receive the best possible signals. Fading on turns is more pronounced with continuous wave transmission than with any other type, although it is noticeable with spark and ICW transmission.

(B) RECEIVING EQUIPMENT.

PART 1.—GENERAL.

Types of receivers.

31-418. Two general types of receivers are now used in aircraft radio. One is the complete-unit type, which contains in one box the receiver proper, the detector circuit, and a two-stage

audio-frequency amplifier. The second type consists of two units, one of which is the receiver while the other is a six-stage radio-audio-frequency amplifier and detector. The general features of the receiver, detector, two-stage audio-frequency amplifier, and the radio-audio-frequency amplifier and detector have already been given.

31-419. The single-unit receivers are divided into two classes, viz, (1) single-circuit and (2) double-circuit receivers. The single circuit, while very simple in operation and an excellent receiver for some purposes, is not selective. Its tuning is broad and therefore interference on near-by wave lengths is very pronounced. The double-circuit receiver is superior to the single-circuit type, but requires more adjustment.

31-420. The following sequence of adjustments to the receiver will give good results:

(1) Turn on current to tubes and by means of rheostat bring the filaments to proper brilliancy. (See Article 31-812 for proper values of filament current.)

NOTE.—*Always burn filaments at the lowest temperature compatible with good results.*

(2) Set the secondary circuit by the condenser to the wave length of the signal to be received. (This circuit of the receiver is generally calibrated.)

(3) Set the coupling between the antenna and secondary circuits at about one-half its maximum value. Adjust the antenna circuit by means of the capacity and the inductance until the signal is heard.

NOTE.—*When the antenna circuit is in resonance with the secondary circuit a certain amount of ignition disturbance will usually be heard; also static will come in with maximum intensity when the two circuits are in resonance.*

(4) When the signal is once heard, readjust both antenna and secondary circuits with very loose coupling.

NOTE.—*The tuning of aircraft receivers is the same as that for receivers in ship and shore installations.*

(5) Adjust the antenna circuit to give maximum signal with this loose coupling and leaving the adjustment of the antenna circuit unchanged. Tune the secondary circuit carefully and close up the coupling slightly.

NOTE.—*Always use the loosest coupling at which the signal can be read because this will reduce trouble from interference, static and ignition.*

31-421. The amplifier used in the installation, whether of the two-stage audio-frequency or of the six-stage radio-audio-frequency type, should be operated as described in Articles 31-527 to 31-538.

31-422. The standard receiver equipment for large planes is the cut-down type SE 950 receiver which is now known as the type SE 1950 receiver. Either the type SE 1605 B or SE 1805 amplifier can be used with their receiver. The amplifier is arranged so that it can be thrown on either the radio compass coil or the secondary circuit of the receiver.

Compass coil
used for receiv-
ing.

31-423. A very satisfactory method of reception in installations on planes provided with ignition prevention devices is to use the compass coil whenever practicable for receiving, and to use the antenna only for transmitting. Interference can then be reduced to a great extent by a slight rotation of the compass coil. A combination of the radio compass coil for receiving and the antenna for transmitting makes an excellent break-in system, because with this arrangement the "Send-receive" switch need not be operated.

PART 2.—RADIO COMPASS.

General.

31-424. The aircraft radio compass is similar in theory to the radio compass used in ship and shore installations. (See Section IX.)

Methods of de-
termining direc-
tion.

31-425. Two methods of determining direction are used in aircraft work, namely, the minimum and the maximum. The first method is the same as that described in Section IX, and is used when the received signal is very loud in the maximum position. The maximum method is employed when the signals are too weak to use the minimum method, that is, when the signals are weak on the maximum setting or when a very broad zone of silence is obtained by the minimum method. In the minimum method the plane of the coil turns is at right angles to the line of bearing of the transmitting station when zero signal is received, while in the maximum method the plane of the coil coincides with the line of bearing of the transmitting station when maximum signal is received.

Operation of
compass coil.

31-426. Successful operation of the compass coil can not be obtained over ranges in excess of fifteen miles unless steps are taken to prevent interference from the ignition system of the motors. This is accomplished on the F-5-L's and the NC-boats by the remote control of the entire ignition system effected by means of the Bowden cable, the switches and ignition batteries being placed very close to the engines. The standard F-5-L installation, provided the plane is equipped with ignition-prevention devices, should give satisfactory bearings on 5 KW transmitting stations at distances up to 100 miles, and fairly accurate bearings up to 150 miles.

PART 3.—INTERPHONES.

31-427. The interphone used on naval aircraft is very much like the ordinary telephone, but by the use of better transformers and microphones the voice is transmitted much more loudly and clearly than over the ordinary telephone. A special type of microphone is used embodying an antinoise feature which permits the transmission of voice frequencies only.

Operation.

31-428. For best results, speak into the microphone fairly loudly and distinctly, keeping the button depressed while talking. The microphone button should not be depressed while listening.

Upkeep.

31-429. The interphone system should be frequently tested, preferably while the motors are being tuned up on the beach. The current for the interphone is supplied by the use of one-half of a type SE 3535 A battery, approximately 11 volts. The loca-

tion of this battery should be kept clearly in mind by the inspecting radioman and should be replaced by a fresh battery when found necessary to give good results.

31-430. (1) The standard aircraft radio helmet, type SE 2000, is provided with soft sponge rubber ear cups to relieve the ear from all pressure. It is exceedingly comfortable, but rather warm in hot weather. The helmet is designed to give a fair signal with a maximum degree of comfort to the operator. If the ear cups are made shallow and bound tightly to the head, better signals can be obtained, but the continual pressure on the ear generally causes a headache. The operator will find it better when very weak signals must be received to press his hands on the outside of the helmet over the ear cups, which will bring the telephones a little closer to the ears. Although this will be a temporary discomfort, it will enable him to receive the signals. The cape at the base of the helmet should be tucked in under the clothing so as to prevent the sound from the motors from entering.

Radio helmet.

(2) Each operator and pilot connected to the interphone should have his own helmet, which should be sewed up to fit his head and marked with his name. It will also be found advantageous to shape the rubber ear cups to fit the contour of the cheek bones just below the ear. For this purpose a very sharp knife should be used.

(C) EMERGENCY COMMUNICATION.

31-431. When a seaplane is forced to the water the trailing wire antenna is no longer available for transmitting purposes. An antenna stretched between the two skid fins of large seaplanes may be used for transmitting, but the range of this small low antenna is very limited. In order to increase the transmitting range for emergency communication, the large seaplanes are now supplied with an emergency equipment, consisting of two kites, one to be flown in a low velocity wind, and the other, which is smaller, for use in winds of higher velocity. The type of kite used maintains a very constant elevation in spite of flaws in the wind. For this reason continuous wave transmission can be used with satisfactory results. Light weight antenna wire of small diameter is used as the kite string.

Purpose.

31-432. Canvas wind tunnels are also supplied for use in connection with transmitting sets which obtain their power from wind-driven fans. This wind tunnel is placed behind the main engine propeller so that the small opening, which is about two feet in diameter, terminates a few inches from the fan driving the radio generator. The generator is mounted in the V strut directly aft of the engine, and is so designed that it may be readily shifted from one motor to another in case one of the motors goes out of commission. The use of the canvas wind tunnel enables full power to be developed by the radio generator at such low speeds of the main engine that the plane makes hardly any headway through the water. This feature protects the seaplane from damage should heavy seas be running.

Special equipment.

31-433. The kite antenna is a very good radiator and also gives excellent results when used for receiving. About 100 feet of spare

Kite antenna.

antenna wire should be carried. This wire should be connected to the base of the generator and thrown over the side into the water for the purpose of obtaining a good ground connection. Tests with this equipment have demonstrated that excellent two-way communication may be obtained over distances in excess of 150 miles.

- Weight.** 31-434. The weight of the additional emergency equipment is very slight and, as the kites are collapsible, the entire emergency gear may be readily stowed in a plane.
- Kite as marker.** The kite, in addition to its use as a means of holding an antenna aloft, also serves as a marker for the disabled plane. The value of this feature is further enhanced by the color of the kite, making it possible for watercraft and other aircraft to locate the seaplane more easily.
- Inspection and drills.** 31-435. The emergency communication apparatus should be carefully inspected and placed on board each seaplane to be so provided before flight. Frequent drills in the use of this apparatus should be conducted. Each member of the crew should be given a number and assigned to a certain duty. When a forced landing is made, each man will go to the location assigned him and complete his duties as soon as possible. This procedure will obviate the necessity of the pilot giving separate orders to each man, and a great deal of time will thereby be saved. It will be seen that the time element is a very important factor, because the plane is usually badly disabled and in a sinking condition after a forced landing has been made.

SECTION VI.—RECEIVING EQUIPMENT. ✓

PART 1.—GENERAL.

- Definition.** 31-450. Receiving equipment includes all the apparatus between the antenna switch and ground connection of a radio station that is used for the reception of radio signals. The following list gives the apparatus used in the service for receiving radio signals:
- (A) Receivers.
 - (B) Amplifiers.
 - (1) Audio-frequency type.
 - (2) Radio-audio-frequency type.
 - (C) Vacuum-tube detectors.
 - (D) Radio-frequency drivers.
 - (E) Special equipment for increasing selectivity.
 - (1) Acceptor-rejector circuits.
 - (2) Model RB receiving equipment.
 - (3) Tuned telephone.
 - (F) Wavemeters.
 - (G) Miscellaneous apparatus:
 - (1) Telephones.
 - (2) Crystal detectors.
 - (3) Vacuum tubes.
 - (4) Condensers fixed and variable.
 - (5) Inductances.

The complete receiving equipment used in any one installation depends upon the type of service required of the installation.

31-451. The collector may be the main or auxiliary antenna or any other antenna constructed especially for receiving, such as the one or two wire antenna of very moderate dimensions. The collector may also be a loop or coil similar to that used in the radio compass installations. Collector.

(A) RECEIVERS.

PART 1.—GENERAL.

31-452. Radio signals are transmitted by either damped or undamped waves. The type of receiver used in the service can usually receive and detect either type of oscillations. The simplest form of receiver is that used for reception of damped wave (spark) signals. The equipment for this purpose includes (1) the collector, (2) the receiver (consisting of three circuits, viz, the antenna circuit, the secondary circuit, and the detector circuit), and (3) the ground connection. The antenna circuit of the receiver is used to tune the antenna to resonance with the frequency of the signal to be received, thereby obtaining a maximum effect in this circuit from the advancing wave. The secondary circuit is also tuned to resonance with the antenna circuit and the maximum amount of current is thereby transferred to the detector circuit which is used for rendering the signal audible.

31-453. The following table gives data on the standard types of receivers now in general use: Types of receivers.

Type No.	Wave length range (meters).	Use.
CN 113-A.....	300-2,500	Unit of one-half kilowatt pack set.
SE 1012-A.....	50-1,000	Radio compass equipment.
SE 1414.....	200-2,000	Aircraft equipment.
SE 1420-C.....	250-6,800	All around work.
SE 1420-D.....	250-6,800	Battleship equipment.
SE 1420-E.....	250-6,800	Do.
SE 1440-A.....	250-1,200	Radio compass equipment.
SE 1530.....	6,000-30,000	Shore station equipment.
SE 1899.....	800-25,000	All around work.
SE 1950.....	300-2,400	Aircraft equipment.
SE 3649.....	800-25,000	Standard battleship equipment.

31-454. The description of a typical radio receiver given in part 2 of this section applies to practically all of the more recent types of Navy receivers except in a few minor details. The SE 1420-C receiver includes the vacuum tube detector. This feature is not present in some of the other types. The present practice is to use inductive (magnetic) coupling between the antenna and secondary circuits as well as between the plate and grid of the vacuum tube circuit. The remarks pertaining to the installation, operation, care and upkeep and faults and their remedies apply in general to all receivers. Inductive back coupling.

31-455. The SE 899 and SE 1899 receivers employ a capacity back coupling for generating oscillations in the secondary circuit for autodyne reception. Although oscillations can be maintained within the range of the receivers mentioned, the strength of the oscillations can not be varied at will as with the inductive back Capacity back coupling.

coupling (tickler), and thereby adjusted to the proper strength for the signal being received. This feature results in a loss of sensitivity and, when the tuned telephone circuit is added to the receiver, oscillations can not be maintained except on the longest wave lengths.

PART 2.—DESCRIPTION.

Purpose. 31-456. The type SE 1420C receiver is intended for the reception of damped or undamped signals between 250 and 7,500 meters. It permits the use of either the crystal or the vacuum tube detector, and contains within itself the receptacle and controls for the latter. Variable back coupling provides for regenerative amplification of damped signals. By virtue of thorough shielding, the receiver is highly selective and proof against local interference.

Antenna circuit. 31-457. The antenna circuit comprises a coil variable in six steps, or taps, and a continuously variable air condenser connected in series between the antenna and ground binding posts. The ordinary antenna acts like a relatively small inductance in series with a relatively large capacity, and its effect upon the tuning of the antenna circuit depends upon the magnitude of these quantities. Consequently, it is impossible to predict the wave length of the antenna circuit at any setting, and it is necessary for the operator to determine the wave lengths, or *calibrate*, the antenna circuit after installation, following the procedure given in article 31-484. The wave length range of the antenna circuit is from 235 to 6,000 meters when the capacity of the antenna is 0.004 μ f., and from 235 to 7,500 meters when the capacity is 0.0009 μ f.

Secondary circuit. 31-458. The secondary circuit comprises a coil variable in six taps connected in series with a continuously variable air condenser, the detector circuit being connected across the terminals of the latter. A pointer actuated by the inductance switch indicates on the proper one of six circles on the condenser dial the wave length to which the secondary circuit is tuned. The wave length corresponding to the different settings of the secondary condenser and the tap or inductance in use are engraved on the upper half of the dial. These markings are spaced 100 meters apart for the shorter wave lengths and increase in value to 200 meters and finally to 500 meters for the upper range of the receiver. The lower half of the dial is marked in degrees. The wave length range of the secondary is from 235 to 7,500 meters.

Fine adjustment. 31-459. Both the antenna and secondary condensers are provided with "fine adjustment" knobs, geared to the movable plate systems in the ratio of five to one.

Shielding. 31-460. (1) Any capacity offers less impedance to the passage of radio-frequency than to the passage of low-frequency currents. Consequently *interference* or intrusion of signals from near-by stations, operating at wave lengths shorter than that to which the receiver is tuned, may occur if there is electrostatic coupling between the antenna and secondary circuits.

(2) Another kind of interference is that resulting from magnetic or electrostatic coupling with a transmitter in the same building or on the same ship as the receiver. This is especially

undesirable in "break-in" systems, where the operator must listen for incoming signals during the pauses of the transmitter, and is likely to be disturbed by loud signals from the transmitter.

(3) To overcome both kinds of interference, the entire receiver is enclosed in a grounded sheet-copper case or *shield*, the antenna and secondary circuits being separated by a sheet-copper partition. This shielding is connected to the positive filament battery terminal and prevents both magnetic and electrostatic coupling between outside bodies and any part of the receiver. Electrostatic coupling between the antenna coil and the coupling coil is prevented by a coupling coil shield which will be described later.

31-461. Magnetic coupling between the antenna and secondary circuits is obtained by means of a *coupling coil* connected in series with the secondary coil and forming part of the first tap, and magnetically linked with the antenna coil. The coupling coil is mounted at an angle of 45° to its spindle, and the antenna coil is fixed at an angle of 45° to this spindle. In this way a 180° rotation of the spindle is obtained in turning the coupling coil from a position at right angles to the antenna coil, in which the coupling is zero, to a position in line with the antenna coil, in which the coupling is a maximum. Thus the 45° mounting affords finer control of coupling than that obtainable with a rectangular mounting.

Coupling coil.

31-462. The coupling coil is provided with an electrostatic shield to prevent electrostatic coupling between the antenna and secondary circuits. This shield consists of an additional winding placed over the coupling coil, wound in the opposite direction to the latter, one terminal being connected to the low-potential or ground end of the coupling coil, and the other terminal being dead-ended (see fig. 31-24). The shielding thus obtained is of course imperfect, so that some radio-frequency alternating current still flows by electrostatic coupling from the antenna coil through the coupling coil to ground, setting up an alternating voltage in the coupling coil, which is impressed upon the secondary circuit and the detector. An equal and opposite voltage is induced in the coupling coil by the displacement current flowing in the shielding coil, completely neutralizing the effect of electrostatic coupling upon the secondary.

Coupling coil shield.

31-463. (1) Oscillations are obtained by means of the back coupler having a stationary part, wound on the main secondary coil tube (see figs. 31-22, 31-23, and 31-24), in series with a rotatable part, wound on a spherical form, mounted inside the secondary coil tube (see fig. 31-24). When the movable part is in the 180° position, its coupling to the secondary coil is added to that of the stationary part; and when it is in the zero position, its coupling is subtracted from that of the stationary part, practically neutralizing it. By virtue of this construction a full 180° rotation of the back coupler is obtained when passing from minimum to maximum back coupling, affording fine control as in the case of the coupling coil.

Back coupler.

(2) Inasmuch as most of tap 1 is in the antenna coupling coil, it is necessary to resort to close coupling of the remainder of tap 1 and of tap 2 to the back coupler in order to secure oscillation

on these taps. Accordingly, the remainder of tap 1 is placed directly over one side of the movable back coupler coil, the stationary back coupler coil being placed between it and tap 2 (see fig. 31-24).
 31-464. A push button is provided near the back coupler knob. When this button is depressed it short-circuits the back coupler and stops oscillation, changing the direct plate current and giving a click in the telephones.

Oscillation test.

Inductance switches.

31-465. Every coil has a natural wave length of its own due to capacity between its turns. In the type SE 1420C re-

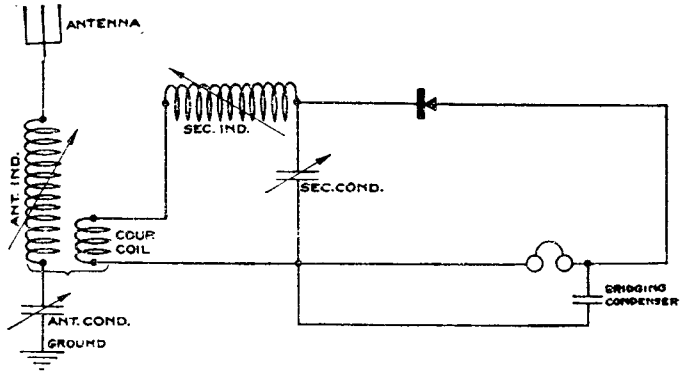

FIG. 31-21.—Scheme of connection for crystal detector.

ceiver, the high-inductance sections of the antenna and secondary coils are resonant at wave lengths within or near the operating ranges of the low-inductance sections. The latter, therefore, tend to induce oscillations in the former, dissipating power and weakening signals. To overcome this, each of the

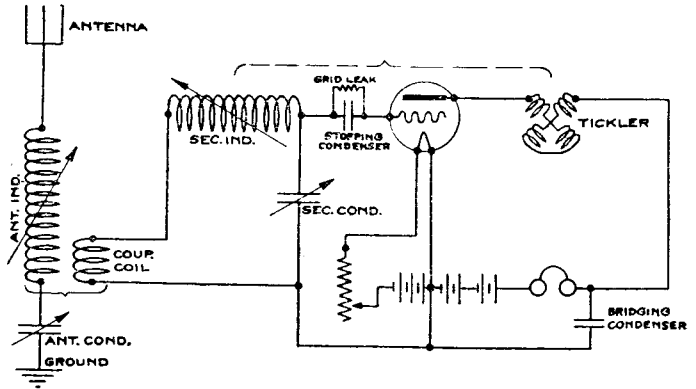

FIG. 31-22.—Scheme of connections for vacuum tube.

inductance switches is provided with a number of blades to short circuit the high-inductance sections when the low-inductance sections are in use, reducing the natural wave lengths of the former by about one-half and bringing them well below the operating ranges of the latter.

Crystal-audio switch.

31-466. (1) A four-pole double-throw "anticapacity" switch is provided for making the connections shown in either figure 31-21

or 31-22. In the set of connections shown in figure 31-21, the grid, plate, and filament are disconnected, both battery circuits are opened to prevent drainage and waste, the terminals of the secondary circuit are connected to the "sec. cond." binding posts, and the crystal binding posts are connected in series with the telephones across the secondary circuit. The "sec. cond." binding posts may then be used for connection to the input terminals of a radio-frequency amplifier, provided that the crystal be disconnected from the "crystal" binding posts (see fig. 31-23).

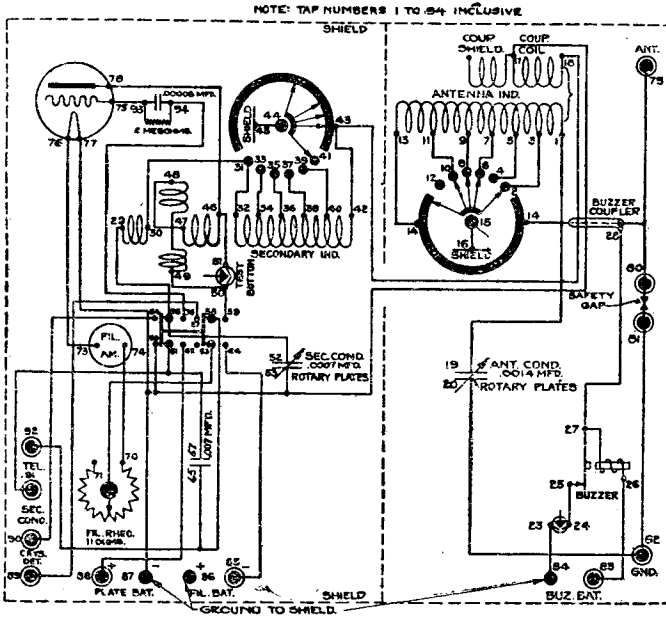

FIG. 31-23.—Wiring diagram (looking at back of receiver).

(2) In the set of connections shown in figure 31-22, the secondary circuit is connected between the grid and the filament, and the back coupler, telephones, and plate battery are connected in series between the plate and the filament.

(3) In the intermediate or "send" position the Crystal-audion switch opens all connections so as to prevent load noises in the telephones when sending.

31-467. The tube mounting carries a four-contact bayonet-joint tube socket, suspended on springs in such a way as to be mechanically shock-proof so that external vibrations will not produce vibration of the tube and consequent noises in the telephones.

Tube mounting.

31-468. A 0.007 μ f mica condenser (65-67, fig. 31-22) is connected between the back coupler and the filament to act as a radio-frequency by-pass around the telephones and plate battery. When operating on the crystal detector this condenser is in series with the crystal and in shunt with the telephones (fig. 31-21). It has six steps, so as to permit approximate tuning with the telephone inductance to the note of the

Bridging condenser.

incoming signal. Incidentally, it serves as an auxiliary oscillation control, as it offers a greater impedance to radio-frequency plate current when set at a low value than when set at a high value, thereby making oscillation more difficult.

Grid condenser and leak.

31-469. The type SE 1420C receiver differs from the type SE 1420 and SE 1420A and B in that the grid bias has been eliminated and, a fixed capacity of $80 \mu\text{f}$, is connected in series with the grid. A high resistance, 2 megohms, is connected across the condenser. It has been found that the over-all sensitivity of the receiver is greatly improved by the addition of the grid condenser and grid leak.

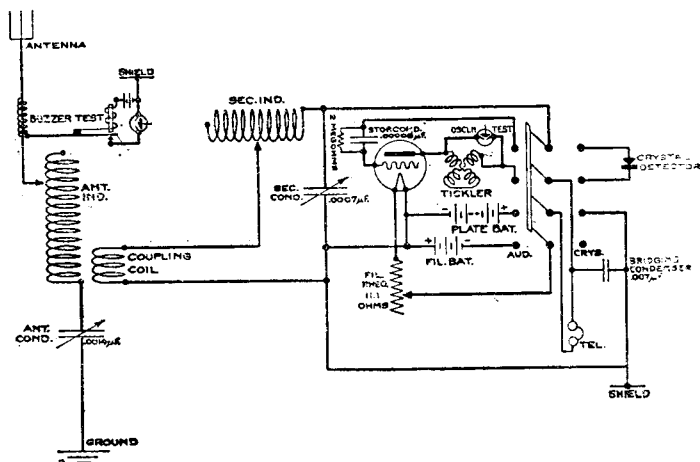

FIG. 31-24.—Schematic diagram.

Test buzzer.

31-470. A buzzer and controlling push button are provided for exciting the antenna circuit into damped oscillation at the wave length to which it is tuned. The exciting circuit is capacitively coupled to the antenna circuit by means of a small metal tube or spiral of wire surrounding the antenna lead and connected to the armature of the buzzer, the stationary contact of the buzzer being grounded. The buzzer enables the operator to tune the antenna and secondary circuits to each other approximately, and to test the performance of either a crystal or a vacuum-tube detector.

PART 3.—OPERATION.

Operating requirements.

31-471. The principal objects sought in the operation of a radio receiver are (1) loudness and clearness of signals, (2) elimination of undesired signals including "static," and (3) rapid "pick-up" work. These objects are antagonistic to a certain extent, and therefore, can not be attained simultaneously as will be made evident in the consideration of the various phases of operation.

Vacuum tubes.

31-472. The following types of vacuum tubes will operate satisfactorily in this receiver:

- Type SE 1444.
- Type CW 933.
- Type CG 899.

The type CW 933 tube is considerably better than the other two for producing oscillation. For detection all three are roughly equal. The type SE 1444 is considered somewhat more sensitive and has the additional advantage that it takes about three-fifths as much filament current as either the type CW 933 or CG 890, and but one-fifth as much plate current as the type CW 933 tube.

31-473. The proper adjustment of filament current is of vital importance in the operation of any tube. While an increase in filament current, within limits, makes a tube a better oscillator, it does not always improve the detecting properties of the tube, and it causes the filament to burn out sooner. The proper filament currents are as follows:

Vacuum tube.	Filament current (amperes).
Type SE 1444-----	0.65
Type CW 933-----	1.10
Type CG 890-----	1.10

Adjustment of
filament current.

Do not at any time unduly increase the filament current as it will weaken the signal and greatly shorten the life of the tube.

31-474. The value of the plate voltage is second in importance only to that of the filament current, and is governed by similar considerations. An increase in plate voltage, in general, improves the tube as an oscillator. The following table gives the plate voltage limits for the three types of tubes, for best detection:

Vacuum tube.	Plate voltage (volts).
Type SE 1444-----	40
Type CW 933-----	40
Type CG 890-----	40

Plate voltage.

31-475. The primary function of the telephone condenser is to tune the telephone circuit to the note of the received signal. This adjustment, however, is not sharply critical in its effect upon signal strength. For high-pitched notes and for crystal operation it will be found better to set the telephone condenser at 1 or 2, while for low-pitched notes it will be found better to set it at 5 or 6. A secondary function of the telephone condenser is the control of oscillation. This use of the telephone condenser will be found necessary under certain conditions. For example, it will be found that with most type CW 933 tubes oscillations can not be stopped at the lower wave lengths on tap 1 unless the telephone condenser is set at 1 or 2. *Always* make the final adjustment of oscillation strength with the back coupler knob.

Telephone con-
denser setting.

31-476. (1) In addition to its function of oscillation control, the back coupler plays an important part in securing maximum loudness of detected signals and high selectivity. To secure this by regeneration in the case of damped signals, increase the back coupling slowly and carefully until the signal in the telephone is loudest. If it is still further increased, oscillation will be set up in the secondary circuit, as evidenced by an irregular hissing sound accompanied by a reduction in strength of signal.

Back coupler.
adjustment.

(2) The adjustment of the back coupler for autodyne reception of undamped signals is almost as critical as that for detection of damped signals. With the secondary circuit in the oscillating

condition, decrease the back coupling slowly until the signal is loudest, at the same time retuning the secondary. *The loudest signal is obtained when oscillations are on the verge of stopping, and not when they are strongest. Should any "howling" be heard in the telephones when the secondary circuit is in the oscillating condition the disturbances may be eliminated by reducing the back coupling.*

Oscillation test. 31-477. To test for the presence or absence of oscillations in the secondary circuit, press the button beneath the back coupler knob. A dull click in the telephones, on both depression and release, indicates the stopping and starting of oscillations. In the absence of oscillations no sound will be heard.

Factors affecting oscillation. 31-478. (1) The factors affecting oscillation in the secondary circuit are as follows:

- (1) Vacuum tube.
 - (a) Filament current.
 - (b) Plate voltage.
- (2) Back coupler setting.
- (3) Telephone condenser setting.
- (4) Antenna:
 - (a) Coupling.
 - (b) Tuning.

Effect of antenna. (2) The effect of the antenna upon the ease of oscillation in the secondary circuit, though not generally appreciated, is quite pronounced. When the antenna circuit is coupled and tuned to the secondary circuit, power is transferred to the former from the latter, producing oscillations in it. The amount of power expended in this way depends upon the characteristics of the antenna; so that different antennas differ in the magnitude of their effect upon the oscillations. An antenna of exceptionally high resistance may stop oscillations on taps 1 and 6. In this case *and in no other* it is permissible to raise the plate voltage to a certain extent—say to 60 volts.

Failure to obtain oscillation. (3) *Failure to obtain oscillations at any wave length setting with an ordinary antenna indicates a defective tube, a defective receiver, or improper manipulation.*

Adjustment of coupling. 31-479. (1) The coupling plays a very important part in the performance of the receiver, and the operator should thoroughly acquaint himself with its action and use.

Loose coupling. (2) At low values of coupling, the reaction between the antenna and secondary circuits is slight, and the tuning of one circuit is virtually independent of the tuning of the other. Consequently two independent selections of wave lengths by tuning are made in the two circuits, and the receiver as a whole is highly selective. This is a desirable condition when there are interfering signals at wave lengths only slightly different from that of the desired signal, and will make loose coupling preferable to tight even at the cost of loudness of signal.

(3) Tight coupling introduces such a reaction between the antenna and secondary circuits that the tuning of one circuit appreciably affects the tuning of the other over wide ranges. With tight coupling the entire receiver is but slightly more selec-

tive than one of the circuits alone. This is valuable in pick-up work, where selectivity is not desired.

(4) Maximum loudness of signal is obtained with neither extremely loose nor extremely tight coupling, but with an intermediate *optimum* value of coupling, which may be found by trial and depends upon the wave length setting and the characteristics of the antenna. Optimum coupling.

31-480. To tune the secondary circuit to a desired wave length, find the wave length among those engraved on the secondary condenser dial (or estimate its position from the nearest engraved mark), set the secondary inductance switch to bring the pointer on the proper dial circle, and rotate the condenser to bring the pointer in line with the wave length mark. using the fine adjustment knob. When the desired wave length occurs on two taps, the tap indicating the greater capacity (higher reading in degrees) is to be preferred because the rate of change per degree in total capacity is less on the upper range of the condenser scale, thus permitting more selective tuning to be made. The dial engraving gives the correct setting when the type SE 1444 tube is used, with 40 volts plate battery and 0.65 ampere filament current, the back coupling being adjusted approximately to the point at which oscillation begins, the antenna coupling being loose. Tuning secondary to desired wave length.

31-481. (1) Any departure from these standard conditions changes the secondary wave length, the following being the important factors: Factors governing wave length of secondary.

- (a) Detector.
- (b) Back coupler setting.
- (c) Coupler setting.
- (d) Antenna tuning.

(2) The capacity of the detector affects the secondary tuning. A crystal detector or type CW 933 tube adds a higher capacity to that of the secondary condenser than a type SE 1444 tube, and consequently gives a longer wave length at a given condenser setting. Detector.

(3) An increase in back coupling increases the secondary wave length, especially on taps 1 and 2. When operating on these taps do not increase the back coupling beyond the point at which oscillation begins, as it reaches resonance with the secondary circuit and becomes the controlling factor in the tuning. Back coupler.

(4) On tap 1, where the coupling coil forms the major part of the secondary inductance, an increase in coupler setting decreases the inductance and therefore the wave length at a fixed condenser setting. This is due to a reaction from the short-circuited portion of the antenna coil. Coupler.

(5) With close coupling, the antenna tuning reacts upon the secondary tuning, as previously stated. Antenna circuit.

(6) The effects of (3), (4), and (5) upon the secondary tuning are particularly marked in autodyne reception at short wave lengths. *Always bear in mind that the secondary dial engraving gives correct wave lengths only when standard conditions obtain.*

31-482. The tuning of the secondary circuit depends upon whether damped or undamped signals are being received. In re- Tuning secondary for signal.

ception of damped signals, tune for maximum loudness. In autodyne reception of undamped signals, silence is obtained when the secondary is in tune with the signal, and as the secondary is detuned to one side or the other, a low "beat note" is heard, which changes to a shrill note as the detuning progresses, finally becoming inaudible. The best "beat note" to use depends upon the individual ear. On short wave lengths the "beat note" becomes inaudible with very slight detuning, so that it may be missed entirely unless careful adjustment is made with the secondary condenser fine adjustment knob.

Antenna tuning.

31-483. (1) For maximum signal strength tune the antenna accurately to the wave length of the incoming signal, regardless of whether the latter is damped or undamped. In stand-by or pick-up work it is desirable to tune the antenna circuit to the secondary independently of incoming signals. This can be done by the following methods:

- (a) Antenna condenser dial calibration.
- (b) Coupling clicks.
- (c) Buzzer signal.
- (d) Static.

(2) In using any of these methods, it will be helpful to remember that, with most antennas, the wave-length range of any tap in the antenna circuit is roughly the same as the wave-length range of the corresponding tap in the secondary circuit. For example, any wave length found on tap 3 of the secondary circuit will usually be found on tap C of the antenna circuit.

Antenna condenser dial method.

(3) *If the antenna condenser dial has been calibrated in accordance with instructions given in article 31-484, simply set the antenna inductance switch and condenser dial to the wave length indicated by the secondary dial. This is subject to whatever error exists in the secondary setting due to departure from standard conditions. It is also subject to error resulting from the action of external influences upon the antenna, such as the motion of large metallic bodies near the antenna, which would change the capacity of the antenna. However, this method of tuning the antenna circuit is sufficiently precise for practical stand-by or pick-up work.*

Coupling click method.

(4) Tighten the coupling to 180 degrees, set the antenna inductance switch to the proper tap, and with the secondary circuit in the oscillating condition, rotate the antenna condenser back and forth. A click will be heard in the telephones at a certain position of the antenna condenser in rotation to the right, and at a different position in rotation to the left. Loosen the coupling gradually and these positions will approach each other, until a *critical coupling* is reached at which they coincide. At the point of coincidence the antenna circuit is tuned to the secondary. If the coupling is further loosened the clicks will disappear. The tuning of the antenna circuit reacts upon the secondary and changes the frequency of oscillation until the antenna circuit is so far detuned that the reaction diminishes and the oscillation returns to normal. This occurs abruptly and produces the click heard in the telephones.

(5) Adjust the buzzer to give a clear note when the button is pressed, and with the secondary in the nonoscillating condition, tune the antenna circuit for maximum buzzer signal in the telephone. This can be done equally well with a tube or a crystal detector. Close coupling gives a loud signal, but broadens the tuning.

Buzzer signal method.

(6) Tune the antenna circuit until a low rumbling or hissing noise appears in the telephones. This may be done with any type of detector, whether the secondary is oscillating or not, but depends upon the regularity and intensity of the disturbances produced by atmospheric electricity, and sometimes fails because of the complete absence of such disturbances.

Static method.

31-484. (1) As soon as the operator has acquainted himself with the use of the various controls and adjustments, he should make it his first duty to calibrate the antenna circuit.

Calibration of antenna circuit.

(2) Adjust the filament current and plate voltage to the proper values for the tube in use. Set the secondary condenser accurately to wave length 300 meters on tap 1. Obtain oscillations in the secondary circuit. Set the antenna inductance switch on tap A and tune the antenna circuit to the secondary by means of "coupling clicks" as described above. *Be sure to adjust both the coupling coil and the back coupling to the lowest settings at which clicks occur.* If due care is exercised, the clicks produced by rotating the antenna condenser in opposite directions should not be farther apart than two degrees. Set the antenna condenser midway between the two click positions and mark the position of the pointer on the dial with pen and ink, first using a soft rubber eraser to remove grease from the dial. Write under this mark the wave length—300 meters. Proceed in a similar manner for all the wave lengths obtainable with the secondary, marking any wave length which occurs on two taps of the antenna circuit at two places on the dial (for example, wave lengths 300 and 400 are likely to occur on both taps A and B). The antenna calibration so obtained will be found invaluable in facilitating the work of the operator.

(3) *Any change whatever in the structure, wires, or connections of the antenna, or the erection or motion of large metallic bodies in the vicinity of the antenna, destroys the accuracy of the antenna calibration. In the event of such a change it is the duty of the operator to erase the writing on the dial, and recalibrate the antenna circuit.*

31-485. To adjust a crystal detector, connect one cell to the "Buzzer battery" binding posts and adjust the buzzer for a clear note. Throw the Crystal-Audion switch to the left. set the antenna and secondary circuits at the same wave length with the assistance of the dial calibrations, and locate by trial a sensitive point for contact on the surface of the crystal, which will give a good buzzer signal. If an antenna calibration has not yet been made, the operator may tune by means of the buzzer and the crystal, provided he can find a point on the latter which is at all sensitive, though it be a poor one.

Adjustment of crystal detector.

31-486. Occasionally the operator is called upon to listen for a particular station sending on a particular wave length. Even

Stand-by work.

in such cases there is generally some uncertainty as to the exact wave length, because of slight inaccuracies in the tuning of both the sending and the receiving apparatus. Therefore, reduce the selectivity or broaden the tuning by the use of tight coupling. If the signals are expected to be very faint, sacrifice broadness of tuning to a certain extent and adjust the coupling to or slightly above the optimum value, as judged from experience. With the aid of the dial calibrations, set the antenna and secondary circuits to the wave length of the sending station, and the back coupler slightly below or slightly above the point at which oscillations begin, depending upon whether the expected signals are damped or undamped.

Pick-up work. 31-487. Ordinarily the operator's duty is to maintain a steady watch for signals on an assigned wave length, recording everything he can read. For picking up powerful signals only, tight coupling and maximum back coupling will facilitate his work. A damped signal will come in with a hissing noise and will be readily recognized. On the other hand, if the operator is required to listen for the faintest audible signals, as is more usually the case, he must constantly keep the coupling at optimum value and the back coupling slightly below or slightly above the point at which oscillations begin, depending upon whether damped or undamped signals, respectively, are sought.

Search for signals. 31-488. *The search for signals consists of continual tuning of the antenna and secondary circuits, keeping the two circuits in tune with each other and traversing repeatedly the entire wave length range within which the signal is expected to be picked up.*

Final adjustment. 31-489. (1) When a signal has been found and it is expected that difficulty will be encountered in copying the message due to interference from other signals, from static, or because of weakness of signal due to the distance over which the message is being transmitted, the following procedure for tuning the receiver to the incoming signal should be invariably adhered to, because the results obtained by this method are uniform, can be repeated any time and, in general, give the loudest signal with least interference from any cause:

- (a) Tune antenna circuit roughly to give maximum signal.
- (b) Loosen secondary coupling until signal is barely heard.
- (c) Retune primary and secondary circuits to give maximum response at this coupling and *do not change primary setting at any time after this operation.*
- (d) Close secondary coupling gradually until the signal reaches maximum intensity.
- (e) Having found position of maximum signal reduce secondary coupling very slightly. This is the point at which reception should always be carried on.
- (f) Vary secondary condenser as required to give best note.
- (g) Should it be necessary to use more inductance in either the primary or secondary circuits the entire procedure outlined above must be repeated because the coupling has been changed.

(2) If necessary, intensity of signals should be sacrificed in order to reduce interference and the secondary coupling can be loosened until the signal desired can be read through the interference, or if, after having made all adjustments, it is still found impossible to copy the message and the interference is on a slightly longer wave length, good results can sometimes be obtained by repeating the procedure just given, but tuning the primary and secondary to a wave length slightly shorter than that of the signal to be received.

(3) The reason that it is impossible to get consistent results with closely coupled tuning is evident when it is remembered that with close coupling the apparent tune of one circuit is changed by every change in the other and that these influences also vary for every change in the coupling, to say nothing of the fact that each of the circuits has also two free periods; so that there is an almost infinite number of combinations which will apparently give the correct tune, but with very small chance that the best combination will be found.

31-490. (1) Measurements of audibility should be made in a uniform manner so that consistent and reliable results may be obtained. The receiver set should be tuned in the manner just described (steps a to g, inclusive) and the secondary coupling left in position (step e). The secondary condenser can be varied as necessary to give best signal and the coupling can also be changed while taking audibility readings, but *under no circumstances should the primary circuit tuning be changed.*

**Audibility
measurements.**

(2) The audibility meter should be connected to the telephone binding posts of the receiver. For received current measurements, amplification should not be used. Either the oscillating or nonoscillating vacuum tube detector can be employed, as the case requires. Amplification can be used whenever strength of signal is to be measured, in which case the kind of amplification and number of stages should be reported.

PART 4.—INSTALLATION.

31-491. (1) In choosing a location for the receiver, bear in mind the operator's convenience in manipulating the control knobs and recording messages simultaneously.

Location.

(2) Fasten the receiver to the table by means of small brass angles and wood screws. In case there is no room for the angles, remove the receiver from the box by unscrewing the ten fastening screws in the front of the panel, drill holes in the bottom, and secure the box to the table by means of wood screws. Do not leave the receiver unfastened on board ship, as the motion of the ship may cause damage to it.

Securing to table.

31-492. Use waterproof lead covered duplex cable for battery leads, and single bare copper or rubber covered wire for antenna, ground, crystal, and amplifier leads. Use no wire smaller than No. 14 American wire (B. & S.) gauge.

Wiring.

31-493. To connect in an audio-frequency amplifier, such as the type SE 1000 amplifier, connect the "telephone" binding posts of the receiver to the "input" binding posts of the amplifier, using the tube in the receiver as the detector. To connect in a

Amplifier connections.

radio-frequency amplifier, such as the type SE 1405 amplifier, connect the lower "sec. cond." binding post to the filament and the upper "sec. cond." binding post to the grid, of the first amplifier tube. Throw switch from "crystal" to "R. F. Ampl" position and turn off current to filament of vacuum tube in receiver.

PART 5.—CARE.

Cleaning. 31-494. While the appearance of the receiver has no direct bearing upon the reception of signals, it is an indication of the care which the operator bestows upon his apparatus and the quality of his work in general. A few minutes a day devoted to maintaining the neat appearance of the receiver will be found conducive to careful manipulation and will be profitably spent. Clean and polish the box, panel, and exposed metal parts with a soft dry cloth. Clean the buzzer contacts, when necessary, with crocus cloth or the finest emery cloth obtainable. Remove the receiver from the box occasionally and go over all parts carefully, wiping off accumulated dust and cleaning all corroded metal surfaces.

PART 6.—REPAIR.

31-495. Every receiver is thoroughly inspected and tested and free from all defects before being sent into service. The mechanism and wiring of the receiver are rugged. Should a fault occur in any part of the receiver it should be remedied on board ship, but it is not intended that such repair include any change whatsoever in the wiring arrangement nor an attempt to improve the receiver electrically. Improvements of this description should only be made with the authority of the Bureau.

**General causes
of failure to
receive.**

31-496. Complete failure to receive signals, or signals not being received with proper intensity, are always indications that the receiving system is out of order, but not that the receiver itself is to blame. Therefore, it is advisable to inspect the circuit from the collector (antenna) to the receiver and thence to ground before looking for trouble in the receiver. The somewhat complicated receiving circuits now being used make such procedure proper unless it can be ascertained by observation that the trouble is in the receiver.

PART 7.—FAULT AND REMEDIES.

Common faults. 31-497. (1) The faults which may occur may be classified as follows:

- (a) Open circuits.
- (b) Short circuits.
- (c) Grounded circuits.
- (d) High resistance or loose contacts.

Open circuits. (2) Open circuits may be caused by the following:

- (a) Antenna switch may be open.
- (b) Crystal-audion switch may be thrown in wrong direction.
- (c) Filament of detector tube burned out.
- (d) Crystal detector not making contact.
- (e) Filament of any tube being used in the amplifier burned out.

- (f) Telephones plugged to wrong stage of amplifier when filament is not lighted.
- (g) External wiring to binding posts broken or binding post not making contact with the wire.
- (h) Open circuit inside the receiver.

(3) The remedies for any of the above faults are obvious and the faults are evidenced by failure of the receiver to operate in whole or in part and by the fact that the receiver calibration has become incorrect. **Remedies.**

(4) It is sometimes found that the wave length of the secondary circuit does not respond to changes made in the secondary condenser. This is determined by the click method; when the antenna circuit tunes to resonance at only one wave length for each step of the secondary inductance it shows that the secondary condenser circuit is open. **Open secondary condenser circuit.**

(5) If the secondary circuit oscillates it is not open circuited. If clicks cannot be heard with tight coupling between primary and secondary circuits when secondary circuit is oscillating, it indicates that the antenna circuit is open, provided a diligent search has been made over a sufficient range.

31-498. Short circuits and grounded circuits are usually evidenced by failure to receive or to operate satisfactorily or when the calibration does not indicate correctly. The condensers should be tested for open circuit, grounding and short circuit. The inductances should also be checked for continuity of circuit and visual inspection made of the interior of the receiver. The testing equipment with which to locate these defects can be made from a 25-watt incandescent lamp connected in series with ship's supply voltage. In using this testing set it is essential that all external connections of the receiver be broken and that the vacuum tube be removed. This is particularly useful in locating a short circuit in variable condensers because a slight spark will occur at the point of contact when the condenser is rotated. Consult the wiring diagram of the receiver when it has been proven that the receiver is at fault before attempting to trace the wiring. Remember the past performances of the receiver and judge the nature of the fault from that viewpoint because the fault usually found is minor unless the receiver has been through an accident. **Short circuits. Grounded circuits.**

31-499. These defects may prevent the receiver from functioning at all or may cause a decrease in received signal strength, more or less marked, depending upon the resistance of contact. High resistance in the secondary circuit will generally require a tighter back coupling to compensate for it. This test should be made with the antenna circuit open; if oscillations are easily maintained with the usual back coupling the secondary circuit is in good condition and the fault probably lies in the antenna circuit. **High resistance or open circuits.**

31-500. Another fault that is very frequently found is due to one or both of the telephone diaphragms sticking to the magnets. Very frequently this is caused by rust collecting on the diaphragm or because the diaphragm has become bent. If the telephone diaphragm is loose it will chatter and the signal will vary in in- **Defective telephones.**

tensity. Telephone trouble is usually easily detected and the remedy is obvious. Defective telephones will reduce the overall efficiency of a receiving set by a surprisingly great amount.

(B) AMPLIFIERS.

PART 1.—GENERAL.

Purpose.

31-525. (1) The *amplifier* is an instrument used for increasing the strength of signal, and invariably employs vacuum tubes, the number of tubes depending upon the degree of amplification required. An amplifier will render audible some signals which would be inaudible without its use and will make incoming signals readable which otherwise would be completely missed. Under favorable atmospheric conditions and with moderate freedom from interference from other transmitting stations and induction from neighboring power and lighting circuits, use of the amplifier is most advantageous. On the other hand, if receiving conditions are not favorable, no great gain results from the use of the amplifier; in other words, the ratio of signal to static remains approximately the same; and when this ratio, without amplification, is not enough to permit reception it is still too low with amplification; and resort to especially selective circuits should be made.

(2) From a military viewpoint the amplifier is of extreme importance in that it permits the use of a collector of very small dimensions. This collector may be a single wire of short length stretched between any two available points, or it may be a small loop. The signal received on such a collector from a given transmitting station will be equal to or even greater in intensity than that received on the usual type of receiver using only a detector even with a large and high antenna as the collector.

Classes of amplifiers.

31-526. There are two general classes of amplifiers, namely:

- (1) Audio-frequency.
- (2) Radio-audio-frequency.

Every amplifier is a complete unit. The two classes of amplifiers are quite different and their characteristics are outlined in the following articles:

PART 2.—THE AUDIO-FREQUENCY AMPLIFIER.

Theory.

31-527. (1) The audio-frequency amplifier is, as its name implies, an instrument for increasing the amplitude of the audio-frequency pulses and may be considered as a telephone amplifier (highly sensitive telephone). This type of amplifier can be used on any wave length for spark, ICW, radio-telephone and heterodyned CW signals. The audio-frequency amplifier is not a detector, but will amplify the current passed on to it from the detector. The detector may be either the well-known crystal type or a vacuum tube. (The vacuum tube is now in general use as a detector.)

First stage of amplification.

(2) The output of the detector (telephone terminals on receiver) passes through the primary winding of a step-up transformer in the amplifier, the secondary terminals of which are connected to the filament and grid of the first tube of the amplifier. The direct current pulses from the detector, passing through the

primary winding of the transformer, induce voltage variations in the secondary winding. These voltage variations are impressed between the grid and filament of the first tube, and produce corresponding current variations in the plate circuit of the first tube. These current variations are many times greater than those in the plate circuit of the detector tube. There is included in the plate circuit of the first tube the primary of another step-up transformer.

(3) The amplified variations of current passing through the primary of the second transformer induce voltages in the secondary of the second transformer, which voltage similarly is impressed in the grid circuit (filament-grid) of the second tube. The amplified variations in current in the plate circuit of the second tube pass through a pair of telephone receivers and a much louder signal is heard than when the telephones are plugged in either the detector circuit or after one stage (step) of amplification. The average two-step audio-frequency amplifier will amplify the signal passed on to it by the detector about four hundredfold (amplification per stage equals 20).

(4) The vacuum tube detector is not a part of the amplifier, but is either included in the receiving set or is a separate unit. Connections are made between the telephone terminals of the detector and the input terminals of the amplifier.

31-528. (1) The following audio-frequency amplifiers are now in use:

Type No.	Type.	Number of stages.	Use.
SE 1000	Tuned, aircore, transformer...	2	General equipment.
SE 1000A	do.....	2	Do.
SE 1000B	do.....	2	Do.
SE 1000F	Iron core transformer.....	2	Do.
SE 1509	do.....	3	Model RA equipment.
SE 1600	do.....	2	General equipment.
SE 1600A	do.....	2	Do.

(2) The three-stage audio-frequency amplifier is, in general, of little use because it is extremely sensitive to induction and vibration (only the first two stages are used in practice). The SE 1440 radiocompass receiver includes the detector and a three-stage audio-frequency amplifier. This and the SE 1599 amplifier are the only three-stage audio-frequency amplifiers used in the service. The following remarks on the SE 1600 A amplifier also apply to the three-stage type of audio-frequency amplifier.

31-529. (1) A schematic diagram of the two-step audio-frequency amplifier is shown in figure 31-25. The complete amplifier is a unit by itself in the receiving system and is equipped with three sets of terminals, two terminals to a set. The *input* terminals connect the amplifier to the receiver, while the *filament battery* and *plate battery* terminals are used for connecting the filament and plate circuit batteries to the apparatus. The filament current for each tube can be adjusted to the proper value by means of a rheostat. The grid voltage is adjusted to the proper value by means of a grid bias resistance of one ohm. Either the SE 1444 or CW 933 vacuum tube can be used for either

Second stage amplification.

Types of audio-frequency amplifiers.

Three-stage audio-frequency amplifier.

Description.

or both stages. Frequently the SE 1444 tube is used for the first stage and the CW 933 for the second stage, with very good results.

- (2) Three telephone jacks are supplied, namely,
 (a) Detector.
 (b) First step.
 (c) Second step.

When the telephones are plugged to the detector jack, the amplifier is cut out of circuit and the telephones are in the detector circuit of the receiver. When the telephones are plugged to the "step one" jack, the detector and the first stage of the amplifier

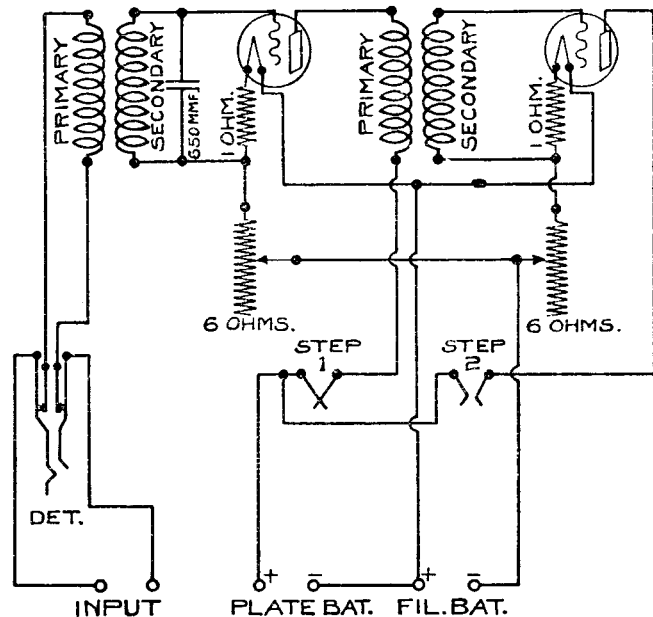

NOTE:-
 DETECTOR JACK OPERATES TWO CIRCUITS AS SHOWN
 STEP 1 JACK IS SHORT-CIRCUITING
 STEP 2 JACK IS OPEN - CIRCUITING

FIG. 31-25.—Schematic diagram of two-step audio-frequency amplifier.

can be used, while the second step remains open. When the telephones are plugged to the "step two" jack, the first step jack short-circuits itself and the detector and the entire amplifier are in circuit.

Operation.

31-530. (1) The audio-frequency amplifier is very easy to operate. The filaments of the tubes should be burned at normal brilliancy. The degree of amplification can be decreased by reducing the brilliancy of the filament of either or both tubes, and can be increased somewhat by burning the filament above normal brilliancy, but the gain in amplification is so slight and the life of the tube so rapidly reduced that this should *never* be done. The current for the filaments may be supplied by either the Edison "A" battery or by any six-volt lead-acid battery. The voltage for the plate circuits should be about forty volts, and for this

purpose two SE 3535A batteries in series, or one Edison "B" battery is required. If the plate voltage is increased to approximately sixty volts, the degree of amplification is increased, but the amplifier is more likely to "howl."

(2) The filaments of both tubes must be lighted whenever two stages of amplification are used, but when only the first step is employed it is not necessary to keep the second tube lighted. When the telephones are plugged in the detector jack, the amplifier is then entirely cut out of circuit, and the filaments of the amplifier tubes should not be left lighted except for stand-by purposes.

31-531. (1) Very little trouble is experienced with audio-frequency amplifiers, but failure to obtain the proper degree of amplification may be due to poor tubes or too low plate voltage. Tubes should be selected for amplifier work, remembering that a noisy tube in the first stage will cause an extremely noisy amplifier when the second stage is also used. **Faults and remedies.**

(2) Howling is generally caused by an open circuit in the *input* of the first stage. The open circuit may be a broken connection from the receiver to the input terminals or a break in the primary winding of the input transformer. **Howling.**

(3) Failure to obtain proper amount of amplification may be due to defective tubes or run down plate or filament battery. The type SE 1444 vacuum tube is erratic in its behavior and new tubes should be tried in the amplifier until a satisfactory set has been selected. **Poor amplification.**

(4) Failure of the amplifier to operate can be due to several causes, among which are: **Failure to amplify.**

- (a) Defective tubes.
- (b) Exhausted batteries.
- (c) Open circuit in any stage.
- (d) Short circuit in any stage.
- (e) Telephones plugged to a stage the filament of the vacuum tube of which is not lighted.

The remedies are obvious.

(5) A defective transformer (open-circuit) can be detected by means of a Wheatstone bridge. The defective transformer should be replaced. **Defective transformers.**

PART 3.—THE RADIO-AUDIO-FREQUENCY AMPLIFIER.

31-532. The radio-audio-frequency amplifier permits a very much higher degree of amplification to be obtained than is possible with the audio-frequency amplifier alone. Its development has made possible the use of extremely small collectors such as the short single wire antenna and the radio compass coil without any sacrifice being made in the intensity of the received signal. The maximum amplification that can be obtained with the radio-audio-frequency amplifier is, in reality, so great that it is not suitable for use on an antenna of the ordinary size. This is caused mainly by the fact that the large antenna collects so much static that the action of the amplifier is paralyzed. In the practical application of this type of amplifier, the apparatus is so designed and constructed that the usual antenna can be satisfactorily used as the collector. **General.**

**Advantages of
radio - frequency
amplification.**

31-533. (1) The addition of radio-frequency stages to the audio-frequency amplifier is very advantageous. Such an amplifier is less noisy because noises due to the tubes and induction from neighboring circuits are not amplified by the radio-frequency stages in the same proportion as the signal. In heterodyne reception of continuous wave signals a decided advantage is gained on all wave lengths. There is always a large amplification obtained on all wave lengths in the reception of spark signals with straight detection; in fact the more radio-frequency stages used for spark reception the better will be the results.

(2) The detector follows the square law, consequently the greater the emf applied to the detector the more efficient it becomes. For this reason it is advisable to amplify before detection. An amplification of 10 times before detection will give 100 times the response in the telephones. For the same reason a radio-frequency amplification of only 5 times is equal to an audio-frequency amplification of 25 times.

(3) The square law action of the detector is shown more clearly by the following:

(4) Suppose a transmitting station is transmitting with 10 amperes in the antenna and that the signal received (detector only) at a given receiving station has an audibility of 10. Now if the current in the transmitting antenna is reduced to one-tenth of its former value—1 ampere—the audibility of the received signal will be reduced to one one-hundredth of its former value—one-tenth of unit audibility. If two stages of audio-frequency amplification are added to the detector and if each stage amplifies 20 times (total amplification— $20 \times 20 = 400$) then the resulting audibility would be 40 and the signal would be heard. On the other hand if two stages of radio-frequency amplification preceded the detector and each stage amplified five times the total amplification would be 25 and the audibility of the received signal would be 62.5 after detection, and 10,000+ if two stages of audio-frequency amplification are used in addition.

(5) The square law of response results in strong signals being very strong and weak signals very weak. In the case of atmospheric disturbances with their strong momentary peaks of intensity, this frequently results in the drowning out of the somewhat weaker signal. On the other hand, when either the autodyne or heterodyne method of reception is employed the current in the telephones is proportional to the current in the antenna. Hence, the response is greater for very weak signals than for loud. Thus, a decided and more favorable ratio of signal to static strength is obtained by the use of the latter method of reception, which, when employed with CW transmission, will result in readable signals with only one-half to one-fourth the current in the transmitting antenna necessary for the same signal intensity with ICW transmission and straight detection.

Theory.

31-534. (1) The radio-frequency amplifier amplifies the voltage variations impressed into the grid circuit from the secondary circuit of the receiver. The voltage across the secondary circuit condenser is applied between the grid and filament of the first tube. This alternating voltage varies at a radio frequency. These volt-

age variations produce corresponding current variations in the plate circuit of the first tube. Most of the voltage amplification takes place in the tube and some in the transformer used between the successive stages. The primary winding of a 1 to 3 ratio transformer is included in the plate circuit of the first tube. The variations in the current passing through the primary winding of the transformer induce a varying voltage in the secondary winding. These variations in voltage are impressed in the grid circuit of the second tube, causing amplified current variations in the plate circuit of this tube.

(2) The same process is repeated for each stage of radio-frequency amplification. The amplified current variations in the plate circuit of the last tube are impressed on the grid circuit of the detector tube. From this point on the action is the same as described in B (1) and C of this section.

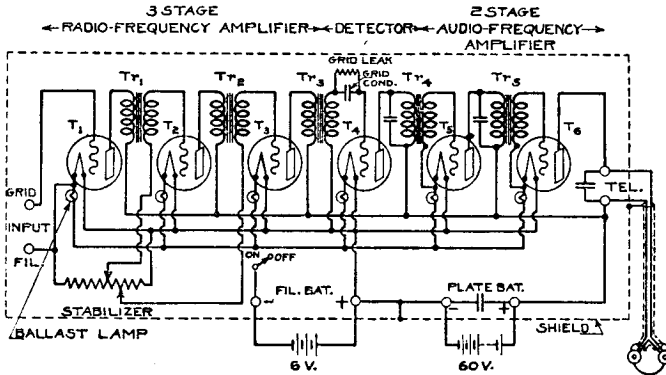

Fig. 31-26.—Type SE 1617A radio-audio-frequency amplifier.

31-535. There are at present five types of radio-audio-frequency amplifiers. They are:

Types of radio-audio - frequency amplifiers.

Type No.	Wave-length range.	Use.
SE 1405B.....	1,600 to 5,200.....	Aircraft.
SE 1605B.....	600 to 1,600.....	Do.
SE 1615.....	1,000 to 8,000.....	Ship and shore station.
SE 1617A.....	6,000 to 20,000.....	Do.
SE 1805.....	500 to 1,000.....	Aircraft.

These amplifiers are all constructed on the same general principle and employ the type SE 1444 vacuum tube. The later models have no filament control, but use the type SE 1719 ballast lamp to maintain the filament temperature constant. A description of the type SE 1617A amplifier follows:

31-536. (1) The type SE 1617A radio-audio-frequency amplifier, which includes 3 radio-frequency stages, 1 detector, and 2 audio-frequency stages of amplification, is contained in a specially shielded box. Figure 31-26 is a simplified drawing of this amplifier.

Description of SE 1617A amplifier.

- Shielding.** (2) The shielding is made of sheet copper and divides the box into 6 double compartments. The lower compartment contains the transformer for one stage. The upper compartment contains the tube socket, vacuum tube, ballast lamp socket, and ballast lamp. The vacuum tube is mounted on a flexible support. By this construction each stage of the amplifier is thoroughly shielded from the others.
- Controls.** (3) The front panel has only three knobs for the control of the amplifier action. These are: The two knobs for the stabilizer which are mounted concentrically and the filament circuit switch. In addition, there are four sets of terminals for making the necessary receiver, battery, and telephone connections, and a telephone cord shield clamp.
- (4) The shield of the amplifier is connected to the + filament battery terminal and therefore has a potential of approximately 6 volts.
- Transformers.** (5) The radio-frequency transformers, type SE 1715, have a 1 to 3 ratio.
- Telephone cords.** (6) The telephone cords are of the shielded type and are used to prevent the capacity of the operator's body from disturbing the action of the amplifier.
- Stabilizer.** (7) The stabilizer consists of a fixed resistance, connected between the + filament battery and the input terminal marked "Fil," and two sliding contacts for varying the grid voltage of the second and third tubes. This places the fixed resistance across the terminals of the filament. Two sliding contacts make the connection to the stabilizer resistance as follows—one to the secondary winding of the first radio-frequency transformer and the other to the secondary winding of the second radio-frequency transformer. The purpose of the stabilizer is to prevent local oscillations in the amplifier and incidentally to control the degree of amplification.
- Connections of type SE 1617A amplifier.** 31-537. (1) The type SE 1617A radio-audio-frequency amplifier should be connected directly across the terminals of the secondary circuit condenser of the receiver. No other apparatus is required except a radio-frequency driver when continuous wave signals are to be received. In this case the radio-frequency driver is placed between the receiver and the amplifier as shown in the front panel view of the Model RB receiving equipment, figure 31-43.
- Vacuum tubes.** (2) The type *SE 1444 vacuum tube only can be used in this amplifier*. One type SE 1719 ballast lamp is required for each tube. No control of the filament temperature is possible. The degree of amplification can be varied within fairly wide limits by the proper use of the stabilizer, maximum signal being received with the stabilizer knobs turned to the right as far as is possible without setting up local oscillations. A freshly charged battery having a high ampere-hour capacity should be used for the filament circuit supply. If, as is generally the case, a radio-frequency driver is used with the amplifier the same filament and plate batteries can be used for both.
- (3) This amplifier should not oscillate and spark signals should therefore be received with their distinctive note unless the radio-

frequency driver is being used, in which case the note will be roughened the same as in autodyne reception.

(4) The following steps should be followed in the operation of the amplifier:

(a) Make all connections to the external circuits as indicated by the terminals (connecting links are usually supplied for this purpose except for the battery connections).

(b) The filament supply should be from a 6-volt storage battery having a capacity of at least 80 ampere-hours.

(c) Use 3-SE 3535A dry batteries in series or one CU 887 or CU 1707 storage battery for the plate supply (60 volts).

(d) Turn filament knob from the "Off" to "On" position. The filaments of all the tubes should light.

(e) When receiving CW signals the radio-frequency driver should be set at approximately the wave length to be received. A signal should then be heard in the telephone.

(f) Adjust the stabilizer by both knobs to give best signal.

31-538. (1) A certain amount of noise will be heard in the tele-
phones when the amplifier is used and, if the noise is not enough **Faults and remedies.**
to mask the signal, receiving can be done. On the other hand a noisy amplifier may be quieted by a careful selection of tubes and a proper adjustment of the stabilizer. Tube noises are most noticeable in the first audio-frequency stage. A noisy tube in the first audio-frequency stage will cause a very noisy amplifier because the noises will be amplified by the second audio-frequency stage.

(2) Failure to receive signals may be due to exhausted bat-
teries, improper setting of the stabilizer, a burned-out filament **Failure to receive signals.**
or an open circuit in any part of the amplifier. The ballast lamps very rarely burn out. It should be remembered that the detector is in the amplifier and that it will be necessary to tune the receiver circuits in the usual manner. The use of the radio-frequency driver adds a slight complication in that, when searching for signals, three circuits require adjustment. For this reason it is very necessary that the radio-frequency driver be set to approximately the same wave length as that of the receiver, as otherwise no signal will be heard. This may cause an apparent failure of the amplifier.

(3) Do not use any more amplification than is required, espe-
cially when there is considerable static. The telephones may be **Degree of amplification to employ.**
worn forward of the ears for loud signals. This deadens the effect of the static and at the same time allows the signal to be read.

(C) VACUUM TUBE DETECTORS.

PART 1.—GENERAL.

31-550. The vacuum tube detector unit is designed to function **Purpose.**
as a detecting system for standard Navy radio receivers. The unit contains the following controls:

- (1) Filament rheostat.
- (2) Filament ammeter.
- (3) Grid condenser.
- (4) Grid leak.
- (5) Bridging condenser,

and filter system with voltage divider for use when the plate voltage supply is obtained from the ship's circuit. Also two change-over switches are supplied, one for changing the plate voltage supply from storage battery to the ship's circuit and the other for shorting out and cutting in the back coupler. Binding posts are provided for making the necessary connections from the vacuum-tube control box to the receiver, filament and plate storage batteries, ship's mains and telephones.

Use.

31-551. The vacuum-tube control box is to be used whenever a vacuum tube detector is required and when the receiving set is

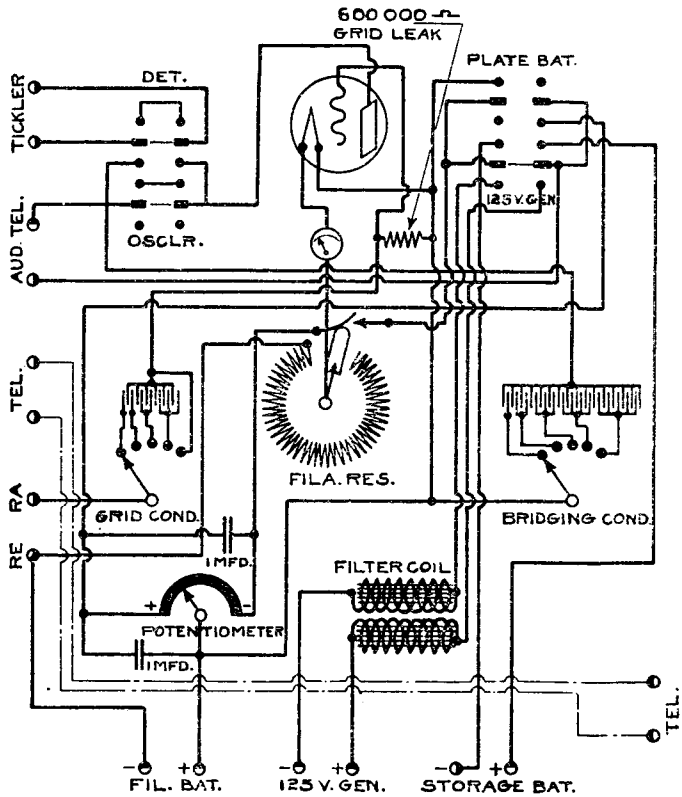

FIG. 31-27.—Vacuum-tube detector, type SE 1071.

not already equipped with a vacuum tube detector, and also when a radio-audio-frequency amplifier is not in use. Only one type of vacuum tube control box is now supplied to the service. This unit is type SE 1071. The diagram (fig. 31-27) shows the wiring of this apparatus.

PART 2.—DESCRIPTION.

Vacuum tube support.

31-552. The vacuum tube is supported from the panel on a shock-proof stand. Either the type SE 1444 or the type CW 933 vacuum tube can be used.

31-553. The filament ammeter is a small flush-type instrument. The zero mark is displaced from the extreme left-hand position for the purpose of giving a positive indication whether or not the filament battery is connected to the unit with the right polarity. **Filament ammeter.**

31-554. The filament rheostat is constructed in such a way that the filament circuit is opened in the "off" position, and in the same position opens the plate battery circuit. **Filament rheostat.**

31-555. Grid and bridging condensers are of the mica dielectric type and are variable in steps. The grid condenser is short-circuited on step 5. **Grid and bridging condensers.**

31-556. The grid leak has a resistance of 600,000 ohms and is constant and also protected from moisture. **Grid leak.**

31-557. The voltage divider consists of a graphite sector having a resistance of about 30,000 ohms connected across the 125-volt line. A sliding contact button connected to the plate of the vacuum tube permits the voltage impressed between plate and filament to be varied as needed only when ship's power is being used. **Voltage divider.**

31-558. The filter system consists of a high impedance choke coil in each side of the line supply and a 1 μ f. condenser connected across the line and another connected between the positive terminal of the plate battery and the sliding contact of the voltage divider. **Filter system.**

31-559. The plate voltage switch changes the plate voltage supply from storage battery to ship's mains. When the plate voltage switch is thrown to "storage battery" the voltage divider is disconnected from the plate circuit to prevent the storage battery from discharging continuously through the voltage divider. **Plate voltage switch.**

PART 3.—OPERATION.

31-560. The vacuum tube detector control box permits straight detection (nonoscillating condition), regeneration, and oscillation. The following steps give the operation of this unit: **General.**

(1) Light filament of vacuum tube by turning the filament rheostat from the "off" position. Use 0.65 ampere for the type SE 1444 and 1.1 amperes for the type CW 933 tube. The plate voltage should be approximately 40 volts for either tube.

(2) Set the "detect-oscillate" switch on "Detect" for the non-oscillating condition (when receiving spark signals with their distinctive notes). **Nonoscillating condition.**

(3) Set the grid and bridging condenser switches on step 3.

(4) Throw plate voltage switch to the proper position—to "125 V. Gen." if it is desired to use the ship's supply, or to "Storage Bat." When the plate voltage switch is thrown to the "125 V. Gen." side the voltage impressed between the plate and filament can be varied, but when the switch is in the "Storage bat." position the potentiometer is out of circuit and no voltage variation can be obtained.

(5) Tune receiver to incoming signal. Vary grid and bridging condensers and plate voltage (when using the 125-volt supply) until signal of maximum intensity is obtained.

31-561. For regenerative reception proceed in the following manner: **Regeneration.**

Set the "detect-oscillate" switch on "oscillate," and increase the back coupling in the receiver to the point just before oscillations begin (the distinctive note of a spark transmitter is roughened when the vacuum tube is oscillating while with regeneration the intensity of the signal is increased without any change in the spark note).

Autodyne reception. 31-562. Continuous wave reception requires that the secondary circuit oscillate. Oscillations can be obtained in the following manner:

Set "detect-oscillate" switch on "oscillate," and vary back coupling until oscillations are present (the presence of oscillations may be detected by tapping the RA terminal with the finger; a click should be heard when this terminal is touched. Also when the tube is oscillating a whistling sound will be heard when the secondary circuit passes through resonance with the antenna circuit.

Adjustment of back coupler. 31-563. The back coupling in the receiver should be set in the minimum coupling position when the "detector-oscillate" switch is in the "detect" position because the back coupler is then shorted and, unless loosely coupled, will cause an increase in the resistance of the secondary circuit, thereby reducing the intensity of the received signals.

Audio-frequency amplification. 31-564. Audio-frequency amplification can be used in connection with the type SE 1071 unit. For this purpose connect the input of the amplifier to telephone terminals of the type SE 1071 unit. Do not attempt to use ship's voltage for the plate supply when the audio-frequency amplifier is being used. This is because the filter system is not perfect and the commutator ripples are amplified to such an extent that the signal will be masked.

PART 4.—FAULTS AND REMEDIES.

Failure to oscillate. 31-565. Failure to obtain oscillations may be due to:

- (1) Reversed back coupling,
- (2) Insufficient plate voltage,
- (3) Insufficient filament current,
- (4) Improperly adjusted grid and bridging condensers,
- (5) Defective vacuum tube.

Filament current. 31-566. The filament current should be kept at the normal value for the tube in use. When it is necessary to cut out all resistance in the filament rheostat the rheostat should be thrown to the "off" position and a new battery placed in service.

(D) RADIO-FREQUENCY DRIVERS.

PART 1.—GENERAL.

Purpose. 31-575. The radio-frequency driver or heterodyne is a low-power generator of continuous waves (sustained oscillations). Its purpose is to supply local oscillations for modulating incoming continuous wave signals and thereby rendering them audible by means of the well-known "beat principle." This instrument is necessary when receiving continuous wave signals except when the detector is used in the oscillating condition (autodyne reception).

31-576. The radio-frequency drivers were developed primarily for use with the radio-audio-frequency amplifiers in which the detector tube is used in a nonoscillating condition, but can be used with any vacuum tube receiving equipment in place of autodyne reception. Use.

31-577. The advantages of using the radio-frequency driver instead of a vacuum-tube detector in the oscillating condition are: Advantages.

- (1) Gives more freedom from interference because detuning of secondary circuit is not necessary.
- (2) Permits a very flexible adjustment of the strength of the local oscillations.
- (3) Makes possible the practical use of radio-frequency amplification for continuous wave reception.
- (4) Reduces the transmitter effect of an oscillating receiver, thereby permitting simultaneous reception by several receiving equipments in close proximity.

31-578. Its main disadvantages are: Disadvantages.

- (1) Requires the tuning of an additional circuit, thereby complicating pick-up work.
- (2) Makes determination of resonance between primary and secondary circuits somewhat more difficult.

PART 2.—THEORY.

31-579. The incoming continuous waves occur at a radio-frequency rate and are, therefore, inaudible even after detection, because the average plate current is changed only at the beginning and end of the dots and dashes. If, however, local radio-frequency oscillations differing by a small amount from the frequency of those being received are impressed on the detector circuit the two sets of radio-frequency oscillations will, on account of their difference in frequency, swing periodically in and out of phase. The amplitude of the resulting frequency at any given instant will be the sum (algebraic) of the amplitudes of the two radio frequencies. As a consequence, a slow audio-frequency oscillation will result which can be heard in the telephones. The resultant audio-frequency can be adjusted at will from a few beats to many thousands per second, the normal beat frequency employed being in the neighborhood of 1,000. Principle of "beat" reception.

31-580. The note will be clear and steady as long as the frequency of both the incoming signal and the radio-frequency driver remain constant. Warbling and bubbling in the signal note is due ordinarily to a rapid change in the frequency of the transmitter (frequently the case with the arc on very short wave lengths, and with the vacuum tube transmitter due to swinging of the antenna or changing capacity effects). A slow and gradual change in the received note is obtained when receiving signals transmitted by a high-frequency alternator having poor speed control and also when the filament or plate battery of the radio-frequency driver is running down. Causes of varying beat note.

Types.

31-581. Three radio-frequency drivers are now in service use. They are as follows:

Type No.	Wave length range.
SE 1602	1,500 to 8,000.
SE 1603	6,000 to 30,000.
SE 1697B	6,000 to 18,000.

These radio-frequency drivers operate on the same principle and are similar in construction with the exception that the first two do not have a grid condenser and grid leak. The following de-

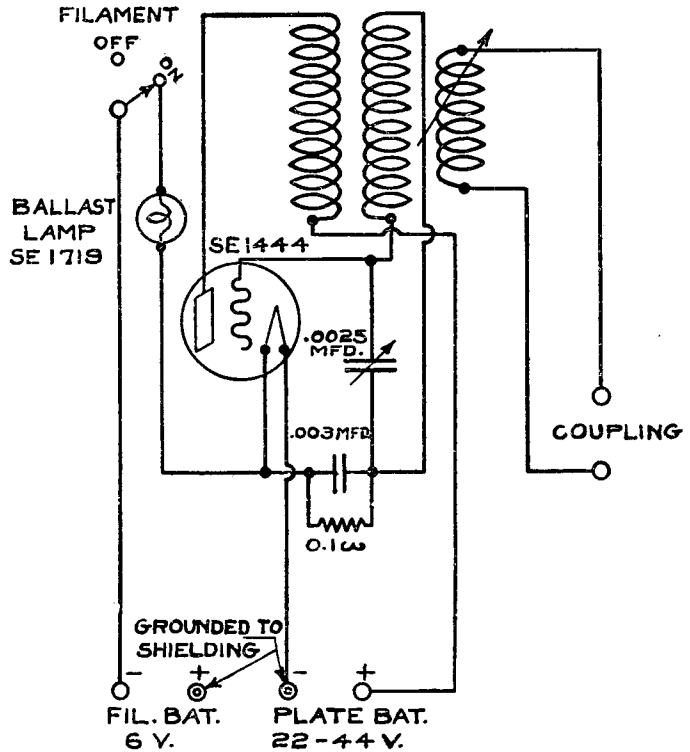

FIG. 31-28.—R. F. Driver, type SE 1697B.

scription of the type SE 1697B radio-frequency driver applies to the other two drivers:

PART 3.—DESCRIPTION.

The type SE 1697B radio-frequency driver.

31-582. The driver is of the tuned grid type with inductive (magnetic) back coupling and its circuit is practically the same as the secondary of the SE 1420 receiver. Figure 31-28 shows a wiring diagram of the driver.

Capacity.

31-583. The condenser is of the continuously variable type with a maximum capacity of 0.0025 μ f.

- 31-584. (1) The inductance in the grid circuit is fixed and wound with extremely fine wire. **Inductance.**
- (2) The plate coil is also fixed, both as to number of turns and coupling with the grid coil. **Coupling coil.**
- 31-585. The coupling coil consists of six turns of wire and its position can be varied with respect to the grid coil, thereby varying the strength of the local oscillations impressed on the detector of the amplifier. The adjustment of the coupling can be varied by turning a knob on the front panel of the driver. The coupling coil is in series with the lead from one terminal of the secondary circuit condenser to the filament of the first radio-frequency amplifier tube (negative terminal). **Vacuum tube.**
- 31-586. The vacuum tube used in this driver is the type SE 1444 requiring 6 volts for the filament circuit and 22 or 44 volts for the plate supply. *Only the type SE 1444 vacuum tube should be used in the radio-frequency driver.* **Ballast lamp.**
- 31-587. The ballast lamp, type SE 1719, limits the current through the filament of the vacuum tube, not allowing the current to rise above 0.65 ampere. **Grid leak.**
- The grid condenser has a capacity of 0.003 μ f. **Wave-length range.**
- 31-588. This resistance has a value of 0.1 megohm.
- 31-589. The wave-length range is 6,000 to 18,000 meters.

PART 4.—OPERATION.

- 31-590. The connections to the radio-frequency driver should agree with the markings on the terminals of the driver. **Connections.**
- 31-591. Fully charged batteries should be used for both the filament and plate circuit supply. Either the lead-acid or Edison type of battery can be used for lighting the filament. The current supply for the plate circuit can be obtained from the type CU 887 or CU 1707 (Edison "B" battery), or the type SE 3335A dry battery. **Filament and plate supply.**
- 31-592. Set the driver to the wave length to be received, allowance being made for enough difference in wave length to produce beats of an audible frequency with the incoming signal. For example, when receiving on a wave length of 6,000 meters adjust the wave length of the driver to a value slightly higher or lower than 6,000 meters. Then adjust the coupling to give maximum received signal. **Tuning.**

PART 5.—FAULTS AND REMEDIES.

- 31-593. The strength of oscillations in the driver can not be regulated because the coupling between the grid and plate circuits is fixed. On this account it will be necessary to keep the plate voltage up to the specified value. The filament current can not be controlled, but as long as the filament battery is well charged the ballast lamp will maintain the filament at a constant temperature which is sufficient for oscillation purposes. However, when the voltage of the filament battery falls below the value required to maintain the filament current at approximately 0.65 ampere, the ballast lamp no longer functions and the oscillations will decrease in strength as the voltage of the battery continues to drop and will finally stop. This condition is evidenced by a de- **Maintenance of oscillations.**

crease in the signal response necessitating an increase in the coupling of the coupling coil to the grid coil of the driver. The remedy is to replace the run down battery.

Strength of oscillations. 31-594. If it is not possible to vary the strength of the local oscillations impressed on the detector of the amplifier by means of the coupling coil adjustment, other tubes should be tried in the driver because, unless the strength of the local oscillations can be varied, the incoming signals will not be received at maximum intensity.

(E) SPECIAL EQUIPMENT FOR INCREASING SELECTIVITY.

(1) *The acceptor-rejector circuit.*

PART 1.—GENERAL.

Purpose. 31-625. The acceptor-rejector circuit is used to increase the selectivity of the radio receiving equipment by means of radio-frequency tuning. The rejector part of the equipment is a separate unit and is used as an addition to the standard Navy receiving equipment, the rejection of the interfering signals being effected in the antenna circuit. The acceptor part of the circuit includes the primary circuit of the receiver.

Selection of signals. 31-626. The selection obtained by the use of the acceptor-rejector circuit is very pronounced. When the adjustments of the acceptor and rejector have been properly made, it will be noted that there is practically no decrease in the signal strength from that which would be received were the rejector not in circuit. In addition, it has been proved that the selection is not confined only to radio signals, but also includes static. By this is meant that static on wave lengths other than that of the signal desired is greatly reduced. The result of the selection just mentioned is that the readability of the signal is increased in proportion as the interference and the static are reduced, thereby making a fairly weak signal actually more readable than would be the case were the rejector not in circuit.

PART 2.—THEORY.

General. 31-627. (1) The action of the "acceptor and rejector" circuits is not hard to understand, nor is the apparatus complicated. Care in making adjustments is required and this, coupled with a grasp of the fundamentals given below and practice, are all that are required.

(2) The ideal receiver would be one which would "accept" and make use of all of the desired signal while at the same time "rejecting" or shunting to ground any and all other interfering signals. Needless to say, like all other ideals, this one has not yet been achieved, but a considerable portion of interference can be eliminated.

(3) To understand the action of the acceptor-rejector circuits it is necessary to review the characteristics of "series" and "parallel" oscillatory circuits.

31-628. Figure 31-29 shows a simple "series" circuit consisting of an inductance and a capacity in series. This is the same circuit that it is encountered in the antenna and secondary circuits of radio receivers. Such a circuit has the lowest impedance when it is tuned exactly to the wave length of the incoming signal or

Series oscillatory circuit.

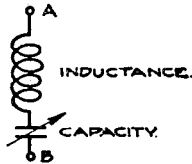

FIG. 31-29.—Simple series circuit.

oscillations. Since the impedance is lowest at this point, it follows that the oscillations in the circuit can rise to the highest value and thus give the greatest signal response. Detuning the circuit either way from this resonant point *increases* the impedance to the incoming wave and therefore causes a corresponding *decrease* in signal strength. This familiar condition is shown

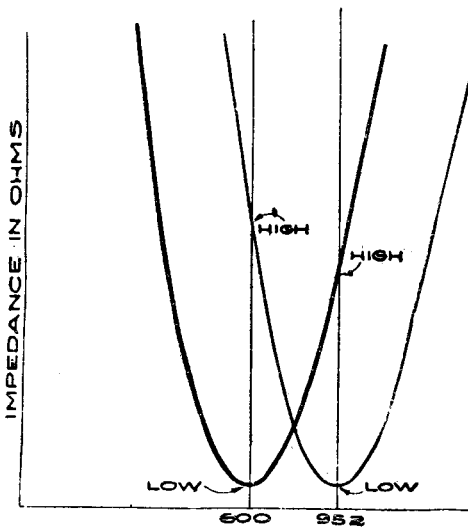

FIG. 31-30.—Wave-length impedance curve for series circuit.

graphically in figure 31-30 where the two curves show the changes in impedance of the circuit, figure 31-29, for two different incoming waves, one curve for 600 meters, the other for 952 meters. Therefore, a series circuit composed of capacity and inductance has lowest impedance when tuned exactly to the incoming signals. This impedance rises rapidly when the incoming signals are out of tune on either side of resonance.

Parallel oscillatory circuit.

31-629. (1) Figure 31-31 shows a circuit in which the inductance and capacity are in parallel with each other with respect to the points A-B, which are the points at which this parallel circuit is attached to the source of oscillations, such as any radio-frequency driver or an antenna and ground system. It should be clearly understood that the secondary circuit of a radio receiver is *not* a parallel circuit, because the oscillatory emf is applied to the circuit by induction *within* the inductance and the current thus set up flows around through this inductance and capacity in *series*. The action is exactly the same as if the circuit were opened between points C and D and the oscillatory emf applied. It will be seen that this last-named condition would duplicate the conditions of the series circuit in figure 31-29. This explanation is made in order that the conclusions drawn below regarding the parallel circuit may not be confused with the secondary of a receiver.

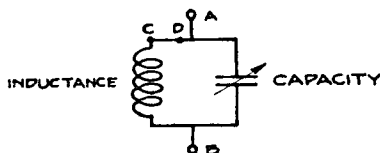

FIG. 31-31.—Parallel circuit.

(2) In a true parallel circuit, the action as regards impedance offered to passage of an oscillating current between points A and B (fig. 31-31) is just the opposite of that in a series circuit. When the inductance and capacity are adjusted to exactly the same wave length as that of the incoming signal or oscillations a very high impedance is offered to the passage of these particular incoming oscillations between points A and B. This impedance falls off very rapidly for incoming signals of wave lengths only slightly higher or lower than that to which the parallel circuit is adjusted. In other words, if two sets of oscillations, say of 600 meters and 952 meters, were simultaneously applied at points A and B and the parallel circuit tuned exactly to 600 meters, the 600-meter oscillations will have extreme difficulty in passing through, due to the high impedance, whereas the 952-meter oscillations will have very little impedance to overcome and therefore pass through readily. This is shown graphically in figure 31-32. Therefore, *a parallel circuit has highest impedance when tuned exactly to the incoming signals*. This impedance falls off rapidly when the incoming signals are out of tune on either side of resonance.

Combination of series and parallel oscillatory circuits.

31-630. (1) It is possible to combine two circuits of such opposite impedance characteristics in a receiver in such a manner that all of the incoming signal desired will be passed through the receiver and used, whereas any other interfering signal of

different wave length will be by-passed to ground and not heard in the telephones. This combination is shown in figures 31-33 and 31-34. These figures are identical except for the location of points A and B. In practice these points are placed directly on the capacity of the parallel circuit, as shown in figure 31-33, for reasons which will be explained later. This is a very important point. In studying this figure it will be seen that, with two incoming signals, 600 meters and 952 meters, the former being the one desired and the latter causing interference, it is possible to separate these two. The 952-meter signal will pass directly to ground because the parallel circuit offers low impedance to this wave length, whereas the series circuit offers high impedance.

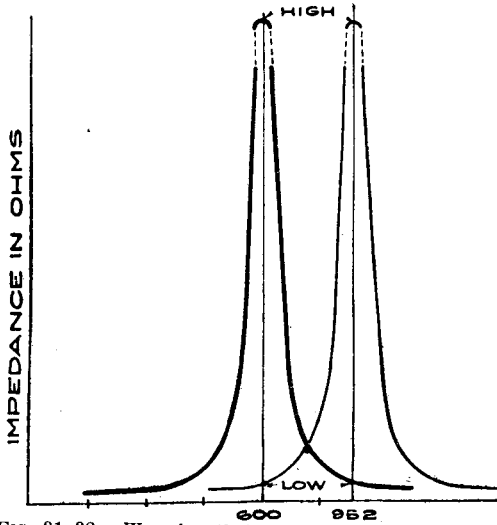

FIG. 31-32.—Wave-length impedance curve for parallel circuit.

(2) The 600-meter signals can not pass directly to ground through the parallel circuit because of its high impedance to this wave length, but takes the path of low impedance, which is the series circuit, and also the primary of the receiver. By coupling to the secondary of the receiver these incoming 600-meter signals can be detected.

31-631. (1) The theoretical or ideal conditions have been assumed in the foregoing discussion. In practice it is found that if the voltage between points A and B of figure 31-33 is very high, then a considerable portion of the 600-meter energy will pass directly to ground through the rejector, with a consequent reduction in received signal strength. To relieve the strain on the rejector and stop this leakage to ground it is necessary to devise some means of keeping the difference of potential of the 600-meter oscillations between points A and B, figure 31-33, very low.

Parallel rejector.

Series acceptor.

Cause of reduction in signal strength.

This can be done. A mechanical and electrical explanation of this action follows:

Mechanical analogy.

(2) Figure 31-35 shows a rope attached at one end to a wall or some other immovable object. By taking hold of the outer end of this rope it is possible to whip it back and forth and set it into oscillation as shown. When this is done, it will be found that there is at least one point (two are shown in the figure) where the rope has no motion, while the rope on either side of this point

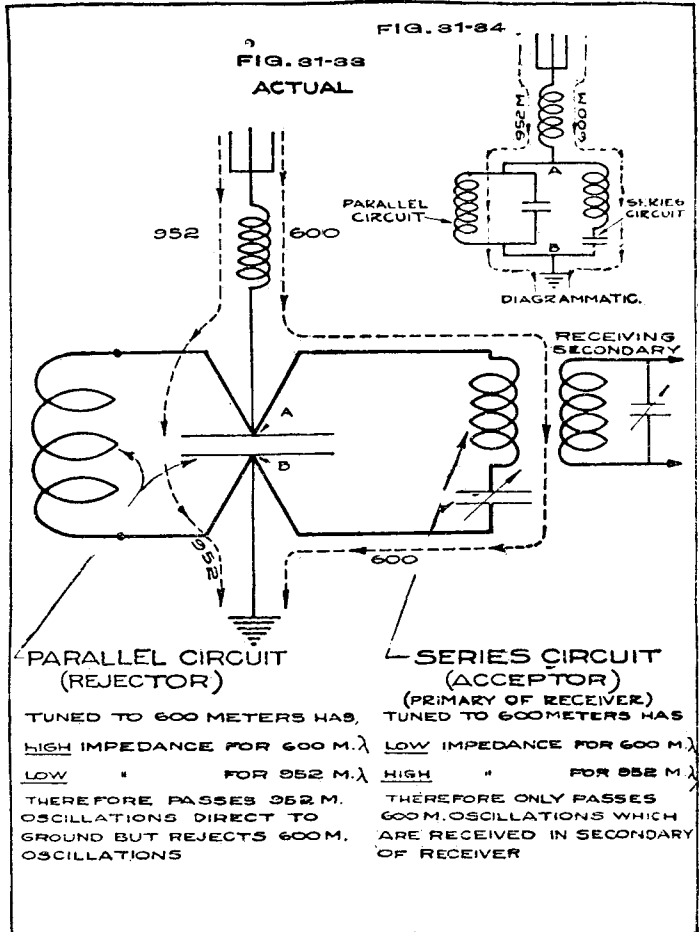

Figs. 31-33 and 31-34.—Actual and diagrammatic acceptor-rejector circuits.

(or points) moves rapidly back and forth. These quiet points in the rope are called *nodal* points, or points of no movement. If, while this rope is in motion, some one grasps it between his thumb and first finger, exactly at this *nodal* point, no change in movement of the rope will result. The rope being stationary at this point, there will be no energy lost in trying to make his arm follow the movement of the rope. If he should grasp the rope at *any other* point where it is moving to and fro, energy will be

taken from the rope in trying to make his hand follow the movements of the rope.

(3) In exactly the same manner, if a circuit is electrically two ^{Electrical action of circuit.} or more times as long as the incoming oscillations there will be one or more nodal points as shown graphically in figure 31-36. At the top of this figure is an arbitrary scale of voltages representing the voltage to ground. This scale has no real sig-

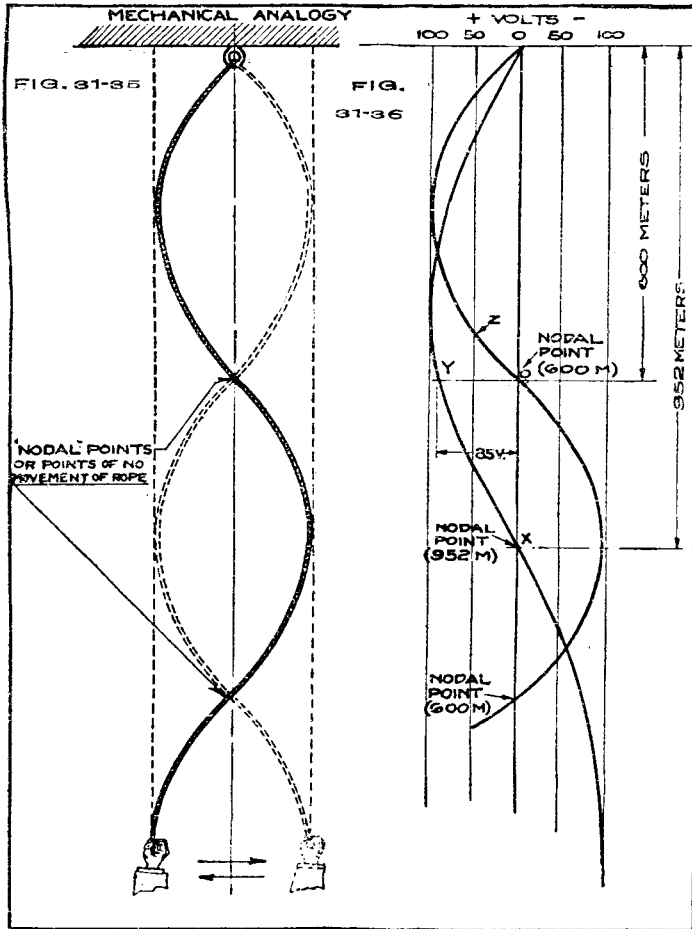

Figs. 31-35 and 31-36.—Mechanical analogy of nodal points of potential in rejector circuit.

nificance and is only relative. According to this scale, the point O could be connected directly to ground without changing the shape of the upper part of the 600-meter curve. If, however, some form of voltage-measuring instrument were connected between the circuit at a point corresponding to point Z, figure 31-36, and ground it would be found that there was a difference of potential of 50 volts between this point and ground. Similarly, with two oscillatory emfs flowing in the circuit, say 600 meters

and 952 meters, as shown, O, there would be zero volts potential to ground from point O for 600-meter oscillations and about 85 volts potential to ground for the 952-meter oscillations. At some point, X, along the circuit we would find a value of potential for the 600-meter oscillations but zero potential to ground for the 952-meter oscillations. In other words, point X is a *nodal* point for 952 meters but not for 600 meters.

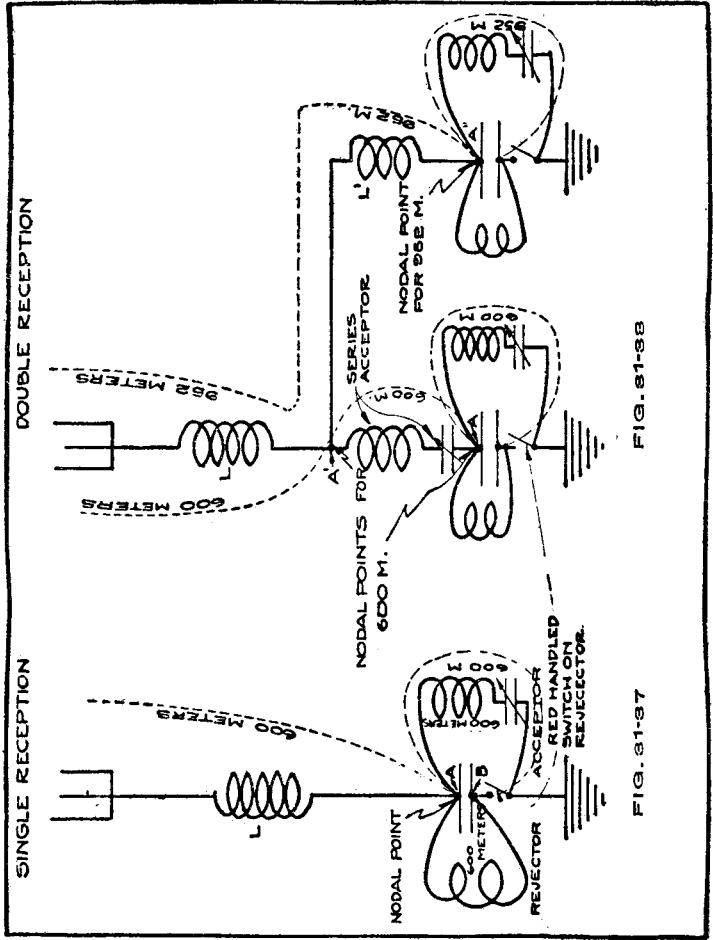

FIGS. 31-37 and 31-38.—Single and double reception acceptor-reflector circuits.

Location of nodal point of potential.

31-632. It would seem feasible, if these *nodal* points can be obtained in a circuit, to utilize this method for getting the low potential across the reflector, which low potential was previously stated to be necessary to reduce the leakage of useful signal energy through the reflector to ground. This is exactly what is done, as shown in figure 31-37. The inductance *L* is adjusted so that with the resulting inductance and the capacity of the antenna this portion of the circuit is exactly in resonance with the incoming signals (600 meters in this case) with a *nodal*

point *exactly* at the terminal of the rejector at A. From a study of figures 31-35 and 31-36, it will be seen that this is just what is wanted. There will be practically zero volts drop in potential straight across between points A and B yet the incoming signals will set up oscillations in the series circuit (acceptor, primary of receiver) which is connected around these points and will, therefore, be heard in the telephones when the secondary of the receiver is properly adjusted and coupled to this acceptor. The red-handled switch, shown in figure 31-37, is used to connect or disconnect the rejector circuit from ground without disconnecting the receiver.

31-633. (1) Figure 31-38 shows the skeleton circuits used when *double reception* on the same antenna is desired. This double reception feature is merely a further use of these same principles. Double reception.

(2) In attempting to receive two different wave lengths on the same antenna, it will readily be seen that it would be necessary to connect the second receiver to the circuit at a nodal point of the first or primary wave length. In figure 31-37, this is point A. This is not practical, though, because all the incoming energy of the desired second wave length would be drained directly to ground and not pass through the second receiver, as it has already been shown that the rejector offers a low impedance path to ground for all wave lengths other than that to which it is tuned. Some form of barrier must therefore be interposed between this point A on the first rejector and the tap-off point for the second wave length which will afford free passage for the 600 meter oscillations but keep out most of the second (952 m.) wave length.

(3) From a study of figures 31-29 and 31-30, it will be seen that a series circuit tuned to 600 meters and inserted in the circuit just above the 600-meter rejector and below the tap-off point for the 952 meter receiver, will do this. There will then be *two nodal* points for 600 meters A and A' as shown in figure 31-38. The antenna circuit down to A' is tuned to 600 meters. The antenna circuit down through A' to point A'' on the 952-meter rejector is tuned to 952 meters, the additional inductance required being supplied by inductance L'. This has no effect on the 600 meter tuning since A' is a nodal point. Also since this additional inductance L' tunes this circuit to 952 meters, we have a series circuit which is so far out of resonance with the 600 meter oscillations that very little if any of the oscillations of this wave length go down this path to ground. Principle.

PART 3.—DESCRIPTION.

31-634. The theory of the acceptor-rejector circuit has been reduced to practice in the following standard types of receiving equipment: Types of equipment.

Name.	Use.
Model E.....	Single and double reception.
Model F.....	Single or double reception with model E.
Model R.....	Single reception only.

Necessary apparatus. 31-635. Figures 31-39, 31-40, and 31-41 show the complete receiving apparatus for the model E, F, and R equipments. The units composing the assemblies may be superseded from time to time but, in the main, the units shown in the figures are typical of the circuit and are required in order to fulfill the purposes of the equipment. For example, the receivers and amplifiers may be replaced by newer and more efficient apparatus, but the elements of the circuit would not thereby be changed. Brief descriptions of the various units of apparatus which are a part of the Model E, F, and R equipments follow:

Antenna tuning inductance, type SE 3524. 31-636. This is a three-unit variable inductance, each unit connected to a control switch located on the front of the panel. The switch on the right controls the large steps of inductance, the maximum being at contact T and is 6 millihenries; the switch on the left-hand side controls smaller steps, a maximum of 0.31 millihenry being at tap t; the center switch controls still smaller steps, a maximum of 0.024 millihenry being at tap (20). This unit is for use either to load the antenna circuit in connection with the SE 3649 receiver or for tuning the antenna when the rejector is to be used.

Antenna loading coil. 31-637. This loading coil is adjustable in six steps, the maximum, 10 millihenries, being at tap 6. This coil is used when the SE 3524 inductance is not large enough for proper tuning; in any case, the SE 3524 coil is used for fine adjustment.

Tuned telephone. 31-638. (1) This unit contains a large audio-frequency inductance, a 0.0025 μ f variable air condenser, and a resistance unit. When the tuned telephone is being used the resistance is placed in series with the plate battery of the SE 1071 vacuum tube detector.

(2) The large inductance, the variable condenser, and the amplifier input or the head telephones are all connected in series and shunted across the resistance and plate battery. The signals passing through the telephones are tuned by means of the variable air condenser.

Rejector shunt. 31-639. This unit consists of a 20 microhenry inductance and a switch. When the switch is closed the inductance is shunted directly across the rejector and the SE 1420 receiver primary. It should only be used during double reception, and is then used so that the rejector red switch may be opened without throwing the long wave receiver out of adjustment.

Rejector condenser. 31-640. This condenser is made up of nine mica units, numbered from 1 to 9, each having a disconnecting switch. The condenser units have the following approximate values:

Switch.	Microfarad.
1-----	0.096
2-----	.012
3-----	.024
4-----	.048
5-----	.096
6-----	.192
7-----	.384
8-----	.768
9-----	1.5
1 to 8 all in parallel (switches closed)-----	1.5

31-641. This inductance consists of two parts, a 12-inch ring and 5 microhenry inductance variable by 18 taps, the first giving 0.4 microhenry and the last 5 microhenries, the steps being practically equal. This inductance is cut into circuit when the big black-handled switch D is open. The smallest tap of inductance is the one nearest this switch and is marked A on the inductance. The ring inductance is variable from 0.09 to 0.4 microhenry, maximum inductance being obtained when the movable arm is at the open end of the ring. As the arm is moved around the ring the inductance caused by the ring varies practically proportionally to the numbers engraved at the edge of the ring.

Rejector inductance.

31-642. This unit consists of a few turns of wire for conductive coupling of test buzzer to antenna; coupling may be varied by steps.

Buzzer coupling coil.

31-643. This fitting is specially arranged for bringing three wires into the booth without destroying the shielding protection and forms a ground terminal.

Booth entering fitting.

31-644. This protective gap is arranged to pass destructive currents to ground without injury to the receiving equipment. Gap should be adjusted to thickness of a piece of paper.

Protective spark gap.

31-645. This unit consists of a 5 millihenry coil of 47 ohms resistance. It is arranged for shunting directly between the antenna and ground when a shunt is necessary for excessive signals, strays, or induced currents.

Antenna leak coil.

31-646. This unit consists of three inductances in series which may be varied in steps by three dial switches located on the panel. The switch on the right, marked with large letters A to T, controls the largest steps of inductance and when on tap T cuts in approximately 2.9 millihenries. The switch on the left, marked a to t, controls smaller steps of inductance, tap t giving approximately 0.16 millihenry. The center switch, marked 1 to 20, gives still smaller steps for fine adjustment, tap 20 giving 0.015 millihenry.

Antenna tuning inductance, type SE 3348.

This unit is used when the rejector is in use. It provides a means for tuning that part of the complete antenna circuit which is above the rejector to the desired signal.

31-647. This unit consists of a 15-step, 0.00065 μf per step, condenser in parallel with a 0.0022 μf variable air condenser. This unit is used in series with the SE 3548 inductance for tuning the antenna circuit above the rejector to the desired wave length. The ratio of inductance to capacity in the antenna circuit may be varied by means of these two units, resulting in a control of the stiffness of the antenna circuit.

Antenna tuning condenser.

31-648. This relay is so arranged that, when the transmitting key is closed, there are two 2 μf condensers shunted directly across the telephones, a ground being made so that there is a capacity of 2 μf between ground and each side of the telephones. This system reduces the note of the local transmitter to a pleasing intensity.

Receiver protective relay.

31-649. This receiver is operative over wave lengths from 250 to 6,800 meters. It contains one detector tube (CW 933) and is adapted to damped (spark) or undamped (arc) signals. Adjustment for these types of reception is made by means of the

Medium wave receiver, type SE 1420 D or E.

back coupling adjusting knob located on the upper right-hand side of the receiver panel. Best spark signals are obtained by starting with the back coupling adjustment at zero and approaching 180 until maximum signal is heard (regenerative). It may be necessary to retune the secondary condenser slightly after regeneration is obtained.

Audio frequency amplifier. 31-650. This amplifier is of the air or iron core transformer type. There are three jacks located at the bottom of the amplifier. The telephone plug may be plugged into any one of these jacks. When in the one on the left the telephones are connected to the receiver tube and no amplification is obtained. The middle jack gives one step of amplification and the one on the right gives two steps of amplification, or an approximate increase in signal strength of 400 over the receiver alone.

PART 4.—OPERATION.

General. 31-652. (1) The various steps of tuning the three acceptor-rejector equipments follow: These steps are given in the correct order and are clearly shown in order that they may be easily followed by the operator. Unless these instructions are carefully followed and the various steps made in the proper sequence, it will not be possible to secure good results with the equipment. Therefore, the proper steps should be thoroughly learned before making the adjustments.

Destroyer installations. 31-653. The instructions for model R equipment given below will apply to the acceptor-rejector installation recently made on six destroyers of the Atlantic Flotilla. Future destroyer installations will have the type SE 3548 inductance and the type SE 3547 condenser combined in one box.

Battleship equipment. 31-654. The equipments for battleships are designated models E, F, and R. They all operate on the same principle but differ in the number of receivers used on the same antenna. Model R equipment is arranged for single reception only. Model F equipment is the same as model R equipment except that it has extra features provided so that it can be used for double reception with one of the receivers in model E booth if desired. The model E equipment is really two receivers, one medium wave and one long wave, arranged so that both receivers can be used simultaneously on one antenna, or either one separately.

Adjustment of acceptor-rejector in model R booths. 31-655. (1) Close switches on inductance type SE 3548 and condenser type SE 3547. (See Fig. 21-39.)

(2) Open *red switch A* and *white switch B* on rejector.

(3) Tune in the desired signal, on *primary* and *secondary* of type SE 1420 receiver, using loose coupling. *Make this adjustment particularly accurate.*

(4) Close receiver *primary short-circuit switch B* (white-handled switch mounted on side of rejector condenser); rotate back coupler knob on the SE 1420 receiver toward 180° until oscillations start. This is shown by clicks in the telephone when oscillation *test button* is pressed and released.

(5) *Rotate primary condenser* of receiver until two clicks are heard in the phones. Leave *primary condenser* one-half way between these two clicks.

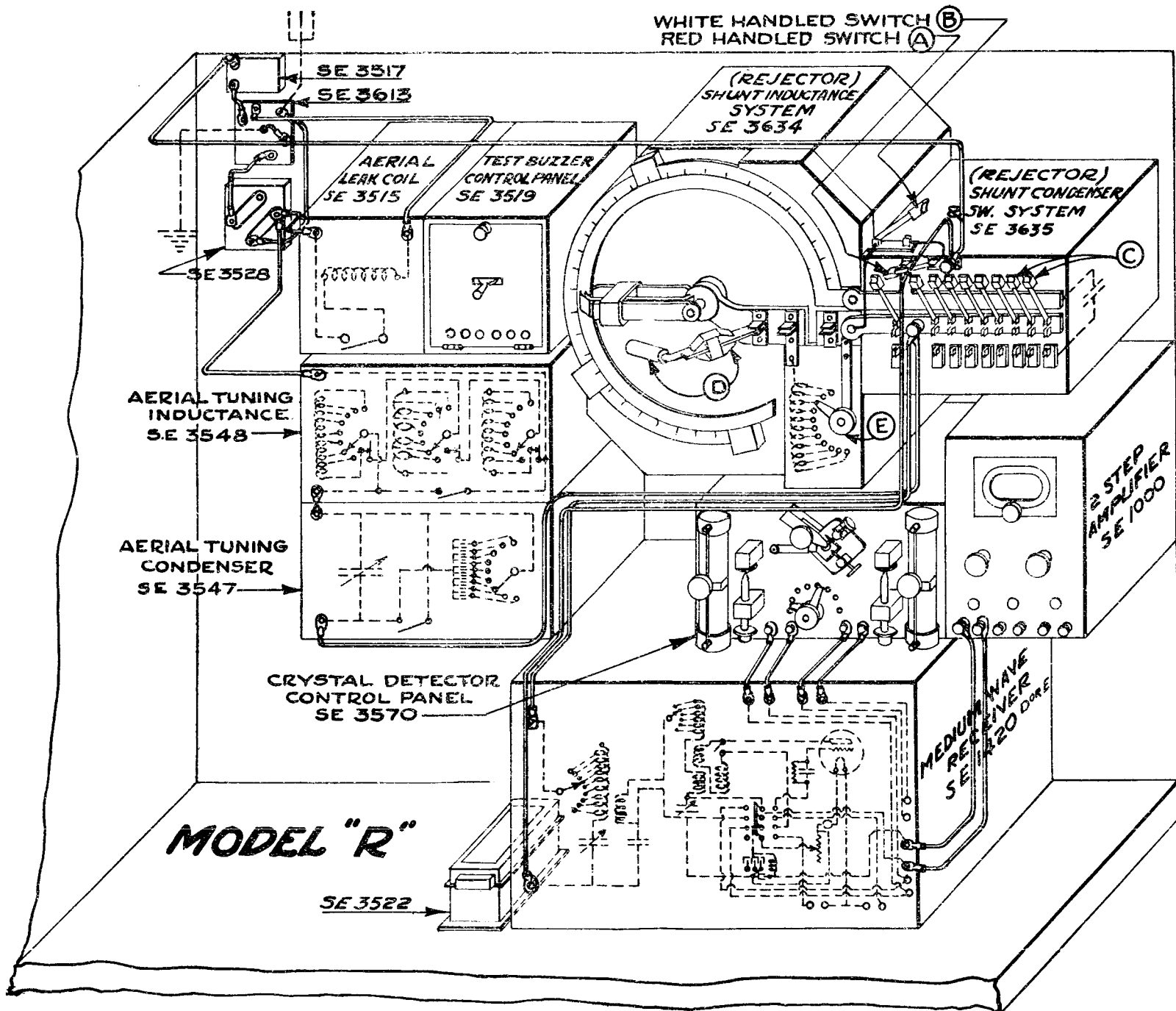

FIG. 31-39. Model R equipment.

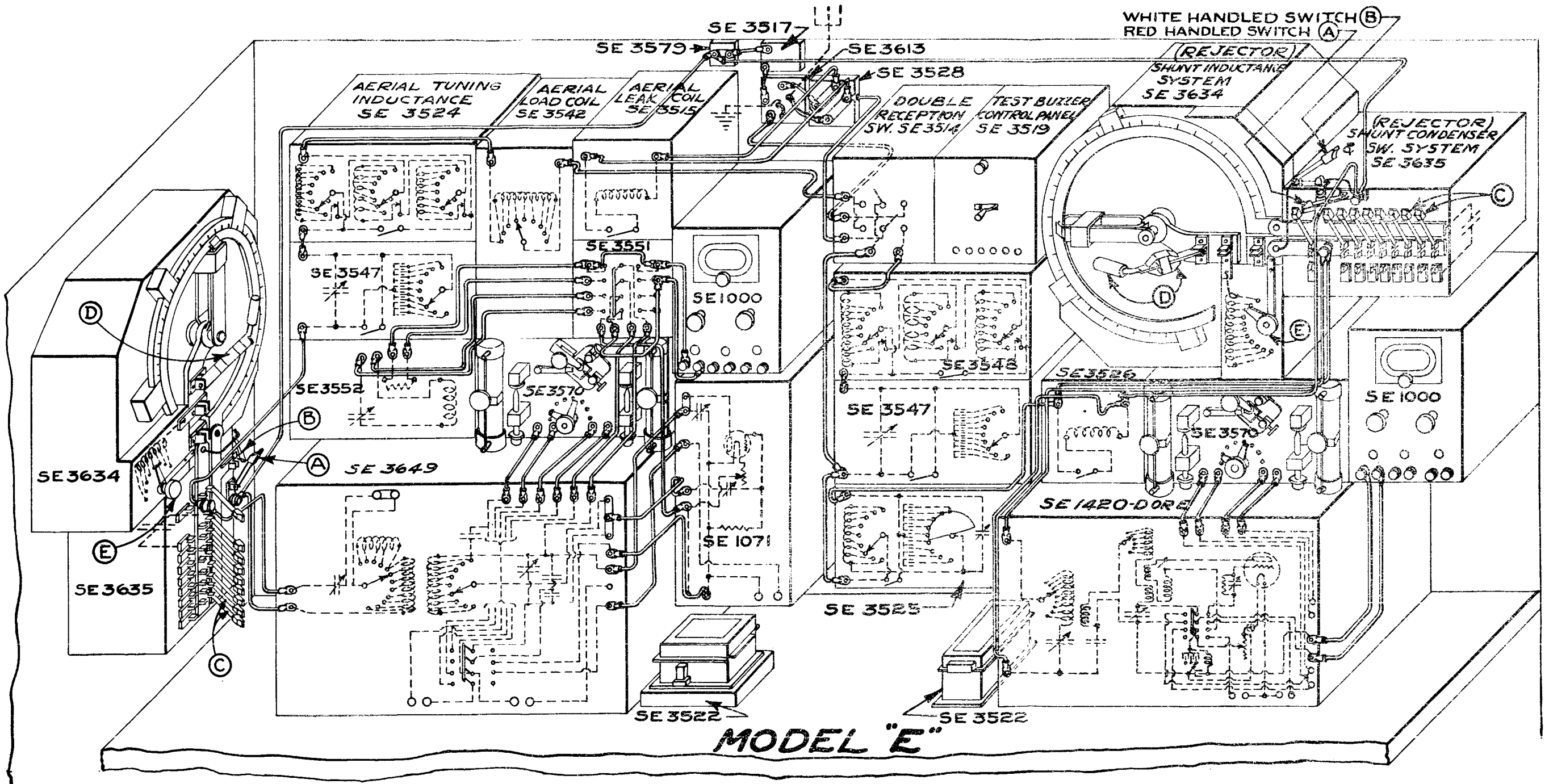

FIG. 31-40.—Model E equipment.

NOTE.—If only one click, or no clicks at all, are heard, slowly rotate back coupler knob in upper left-hand corner of SE 1420 receiver until two clicks are heard when *primary condenser* is rotated. If these clicks are not obtained with back coupling near 0° (loose coupling), then rotate knob toward 180° . This strengthens the oscillations.

(6) (a) Open *receiver short-circuit switch B* (white-handled switch) and switches on the SE 3548 *inductance* and the SE 3547 *capacity*; then adjust these until maximum signal strength is obtained; next test the use of capacity near 90° and adjust the inductance by large steps. These are all on right-hand switch, small steps are on the left-hand switch, and single turns are on the center switch.

(b) Experience and trial will show what the best values of inductance and capacities are for the various wave lengths. Conditions may arise under which either the capacity or inductance is best used alone.

(7) Close the *red-handled switch A on the rejector* and adjust rejector for maximum signal. Start adjustment by closing the first three or four *black-handled switches C* on the rejector condenser; *open the large switch D* of the rejector inductance and rotate the *small inductance switch E* from A toward K until signal is heard; make fine adjustment with *single-ring inductance*. If signal is not heard when K is reached, open the *red-handled switch A* and see if the signal is still coming in. If so, close the next *black-handled condenser switch C* and repeat the operation when adjustment is found. Opening or closing the red switch must not weaken nor strengthen the signal. If the signal can not be found or is weakened by this operation, the *antenna inductance SE 3548*, the *capacity SE 3547*, or the SE 1420 *primary* (left-hand knob of receiver) are out of adjustment.

(8) *Go back and start all over when this condition is found.*

(9) After the signal has been found by the above directions, the *rejector is not yet set* for its greatest selectivity. Greatest selectivity is found by moving the small switch toward A and closing more *black-handled condenser switches*, retuning each time with the single-ring inductance. *Greatest selectivity will be found* when the big switch D is closed and the ring alone is used; to use less ring, close more black switches. A very slight decrease in signal strength may be expected on closing the red switch when the ring alone is being used, but the interfering signal should be reduced practically to zero.

31-656. (1) The model E equipment is really two receivers, Model E equip-
ment. one long wave and one medium wave, designed primarily for using both receivers at once on the main antenna, double reception. It is arranged, however, so that either receiver may be used alone on the main antenna or the long-wave receiver can be used for double reception with the medium-wave receiver of the model F equipment if the medium-wave receiver in model E booth goes bad. (See model F instructions.) Each method of reception is described separately. (See Fig. 31-40.)

(2) To use medium-wave receiver *alone without* acceptor-rejector:

(a) *Open upper* switch double reception switch box SE 3514; throw *lower* switch to *right*.

(b) *Close* short-circuiting switch boxes SE 3548, SE 3547, SE 3525.

(c) *Open* red switch A and white switch B on rejector.

(d) *Open* switch on SE 3526 shunt inductance.

(e) *Tune* receiver SE 1420 in same manner as any ordinary receiver not equipped with acceptor-rejector.

(3) To use medium-wave receiver *alone with* acceptor-rejector:

(a) *Open upper* switch double reception switch box SE 3514; throw *lower* switch to *right*.

(b) Then proceed as directed under model F, using acceptor-rejector.

(4) To use *long wave* receiver *alone*:

(a) *Open upper* switch double reception switch box SE 3514; throw *lower* switch to *left*.

(b) Put switch on antenna load coil SE 3542 on *0*.

(c) *Close* short-circuiting switches on SE 3524 and SE 3547.

(d) *Open* red switch A and white switch B on long-wave rejector.

(e) Use the SE 3649 receiver and SE 1071 vacuum tube detector as usual for ordinary long-wave reception.

(f) If switch on SE 3551 is thrown to *right*, the tuned telephone SE 3522 is *not* in use.

(g) The tuned telephone should be used in all cases where static or other interference is bad. To use it, tune the incoming signal to the desired pitch or note by adjusting secondary condenser of SE 3649 receiver; then throw switch on SE 3551 to *left*, and rotate variable condenser handle on SE 3552. Tune telephone until *loudest* signal is heard in head telephones. If the tuned telephone is operating properly, the signal strength will be retained, but the interfering signals or static will be decidedly reduced. The tuned telephone works best when a high-pitched signal is used.

(5) To use double reception:

(a) *Open upper* switch double reception switch box SE 3514; throw *lower* switch to *right*.

(b) *Close* switches on SE 3548, SE 3547, and SE 3525.

(c) *Open* red switch A and white switch B on medium-wave rejector.

(d) *Tune in* desired signal, on *primary* and *secondary* of SE 1420 receiver, using loose coupling. *Make this adjustment particularly accurate.*

(e) *Close* receiver primary short-circuit switch B (white-handled switch mounted on upper side of rejector condenser); rotate *back coupler knob* on SE 1420 receiver toward 180° until oscillations start. This condition is indicated by clicks in the telephone when oscillation *test button* is pressed and released.

(f) *Rotate primary condenser* of SE 1420 receiver until *two* clicks are heard in phones. *Leave primary condenser* at point halfway between points where these clicks are heard. (See note in par. 5, article 31-655.)

(g) Open white switch B and switches on SE 3548 and SE 3547 (leaving switch on SE 3525 *closed*), and adjust inductance SE 3548 and capacity SE 3547 until maximum signal is again heard; then test the use of capacity near 90° and readjust inductance. (See par. 6 (b), article 31-655.)

(h) Close red switch A on rejector and adjust rejector. (See par. 7, article 31-655.)

(i) *Start all over again* if signals weaken when red switch A is closed after rejector has been adjusted.

(j) *Leaving the rest of the apparatus exactly* as adjusted above, open the switch on series acceptor box SE 3525 and adjust the inductance and capacity in *this* box until same signal strength is again obtained. *Do not adjust any other part of the circuit while tuning this acceptor.*

(k) The long wave receiver is now ready to be connected in and adjusted.

(l) Throw *upper* switch (previously open) on SE 3514 to *left*. If wave length of signal to be copied is *greater* than 3,000 meters, it will *not* be possible to use rejector on the long wave side. In *this* case adjust long wave receiver exactly as any ordinary long wave receiver.

NOTE.—It is possible to readjust the long wave receiver to different wave lengths without *affecting* the medium wave side, *but* it is *not* possible to make *any* adjustment of the *medium wave receiver*, the inductance SE 3548, condenser SE 3547, or acceptor SE 3525 without throwing set entirely out of adjustment. If this is done by mistake, *start all over*.

(m) If the wave length to be received on the long wave receiver is within the range of the rejector (that is, *below* 3,000 meters), proceed as follows after performing operations given up to par. 5(k) above:

(n) Set switch on SE 3542 on 0, *close* switches on SE 3524 and SE 3547, and open red switch A and white B on long wave rejector.

(o) Adjust primary and secondary of SE 3649 receiver for maximum signal; then close white switch B and get resonance clicks exactly as described for medium wave receiver above. Open white switch B and switches on SE 3524 and SE 3547. Vary inductance SE 3524 and condenser SE 3547 until maximum signal is again obtained. Close red switch A on rejector and adjust rejector, as previously explained, under medium wave receiver.

(p) Remember that the tuned telephone, when used on long wave CW signals and *properly* adjusted, gives the same results as the rejector, which will only go up to 3,000 meters.

(q) Whenever it is desired to *open* the red switch A on the medium wave rejector, the switch on the shunt inductance SE 3526 should be *closed first*. This prevents serious weakening of the long wave signals and should not seriously affect the strength of the medium wave signals.

(r) If the medium wave receiver must be retuned to a new wave length the above adjustments must be repeated.

Model F equip-
ment.

31-657. (1) This equipment is a duplicate of Model R equipment, except that it has in addition the following parts to provide for double reception with the long wave receiver in model E booth when for any reason the medium wave receiver in the Model "E" booth is not in use:

1 SE 3590 single-booth double-reception switch.

1 SE 3525 series acceptor.

1 SE 3526 shunt inductance.

(2) To use model F equipment alone *without* acceptor-rejector:

(a) *Open* switch on SE 3590 and *close* switches on SE 3548, SE 3547, and SE 3525. (See Fig. 31-41.)

(b) Open red switch A and white switch B on rejector and switch on SE 3526 shunt inductance.

(c) Tune primary and secondary of SE 1420 receiver in same manner as any ordinary receiver not equipped with acceptor-rejector.

(3) To use model F equipment *alone with* acceptor-rejector:

(a) *Open* switch on SE 3590 and *close* switch on SE 3525 and then proceed exactly as described for model R. *Do not open switch* on series acceptor SE 3525 unless using double reception with model E booth, as described below.

(4) The method of double reception on main antenna using the medium wave receiver in model F with the long wave receiver in model E is provided to give a means for such double reception in case the medium wave receiver in model E booth is damaged or becomes inoperative. *Before* it can be used it is necessary to change the connections of the switches in the copper buses which connect models E and F booths and the antennas. The double bus switch in the center of this bus structure should be shifted so that the main antenna goes to the model F booth and the double reception lead from model F booth is connected to the antenna lead of the model E booth. The auxiliary antenna lead to model F booth should be disconnected. *Trace out the connections.*

(5) To use model F equipment *double reception* with long wave receiver in model E booth:

(a) Open upper switch box SE 3514 in model E booth; throw *lower* switch to *left*.

(b) Throw switch on box SE 3590 in model F booth to *left*.

(c) Then proceed exactly as described under model E for double reception, except that the medium wave tuning will be done in model F booth and the long wave tuning in model E booth.

PART 5.—FAULTS AND REMEDIES.

Care of silver-
plated surfaces.

31-658. The rejector part of the models E, F, and R equipments is rugged. It is designed and constructed with a large factor of safety as regards both the mechanical and electrical features. It should, therefore, develop no faults. All conductors are silver-plated for the purpose of decreasing the skin-effect of the radio-frequency currents and to reduce contact resistance. The silver-plating is not very heavy and, although all the apparatus should

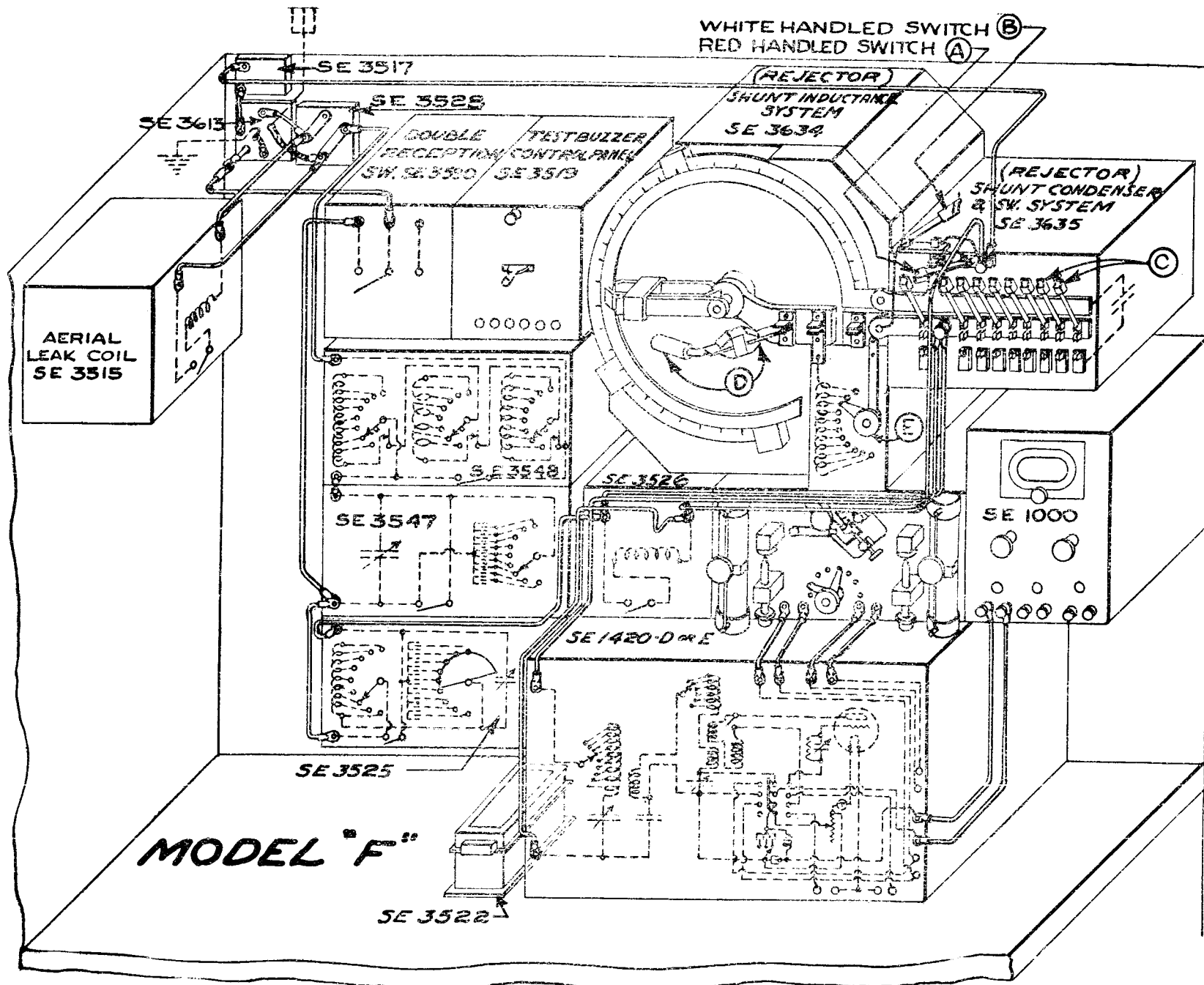

FIG. 31-11. Model F equipment.

be kept clean and bright, no bright work polish should ever be used on the silver-plated surfaces. There are two reasons for this, namely, it is practically impossible to remove all the bright work polish and the result is a gumming of the moving parts, with resultant friction and wear. The other reason is that the thickness of the silver plating is rapidly reduced by frequent polishing.

31-659. It will be noticed that the knife switches on the condenser type SE 3635, and on the inductance type SE 3634, are provided with additional contacts so that the resistance due to the pivot is eliminated. These switches are frequently operated and the revolving arm on the inductance is also frequently moved. It is essential, therefore, that all bearing surfaces be as free from friction as possible. All the contacts and metal surfaces should be wiped daily with a piece of cheesecloth previously dipped in some fine machine oil, such as typewriter or sewing machine oil. The thin film of oil which will adhere to the surface will reduce friction, improve the contact, and prevent oxidization.

Reduction of friction.

31-660. If the apparatus has been installed in accordance with standard plans, the only fault that can arise will then be due to a defective unit in the equipment. A thorough knowledge of the operation of the equipment will aid greatly in determining where the fault is.

Defective unit.

31-661. It is well to remember that the *greatest* selectivity is obtained by the use of the *least* amount of inductance in the rejector, in which case the *greatest* amount of capacity will be cut into the circuit.

Selectivity.

31-662. No additions nor alterations to the equipment should be made except with authority from the Bureau.

No alterations.

31-663. The acceptor-rejector is rather new in the service and the information on its behavior and faults and remedies is meager. If the theory, operation, and description of the equipment just given be thoroughly understood, it is thought that very little trouble will be experienced and that excellent results will be obtained.

Information on performance of equipment.

(2) *The Model RB Receiving Equipment.*

PART I.—GENERAL.

31-675. The model RB receiving equipment has been developed primarily for shore radio station use and, consequently, has been given a wave length range of 6,000 to 30,000 meters. This equipment is, however, applicable to use on shipboard.

Purpose.

31-676. The model RB receiving equipment is a combination of circuits and collectors giving exceptional selectivity both in wave length and direction. The ordinary receiver, such as the type SE 1420, is not especially selective as to wave length and has no directional qualities. No two-circuit receiver can be as selective as a three-circuit receiver. In addition, the vacuum tube detector (nonoscillating or oscillating) causes the secondary circuit of the receiver to tune broadly. This effect is very noticeable with the vacuum tube detector in the nonoscillating condition when receiving continuous wave signals with heterodyne. Fur-

Comparison with other receiving equipment.

ther, the ordinary antenna circuit usually has a high resistance, thus decreasing sharpness of tuning in the ordinary receiver.

Aids to selectivity.

31-677. The model RB receiving equipment utilizes all the aids to selectivity in wave length and direction at present known to the radio art. These are as follows:

(1) Directional Selectivity.—(a) Advantage is taken of the directional characteristics of the radio compass coil.

(b) The combination of an antenna of moderate size and a radio compass coil gives a "barrage" effect by eliminating reception from one direction and doubling the strength of signals received from a direction opposite the null point.

(2) Wave Length Selectivity.—(a) Considerable selectivity is gained by the use of low resistance circuits throughout the equipment. (This selectivity is appreciably greater than that of the type SE 1420 receiver).

(b) A third circuit is interposed between the primary and secondary circuits of the receiver. This circuit is called the "intermediate" circuit, and broad tuning of the secondary circuit is thereby eliminated.

(c) Reception of continuous waves is by the heterodyne method. (In this method detuning of the primary and secondary circuits is obviated, thereby increasing freedom from interference, and also obtaining maximum effect from incoming signals.)

(d) Further selectivity is gained by the use of radio-frequency amplification.

PART 2—THEORY

Collector system.

31-678. The model RB receiving equipment, as stated above, uses a double collector for receiving signals. This double collector consists of a fairly large loop (8 feet square, wound with 48 turns of wire spaced eleven-sixteenths inch apart), and a single wire antenna having a length of about 200 feet and a height of about 75 feet at the far end. The antenna itself is not directional, that is, it will receive equally well signals coming from any direction. On the other hand, the loop will receive signals with maximum intensity only when the loop points toward or away from the station being received. In other words, the loop has two points of maximum reception situated 180° apart and two points of minimum reception also situated 180° apart, the line connecting the latter being at right angles to the line joining the former. (In practice, the antenna circuit is coupled to the loop circuit through a suitable coupling arrangement, and the emf impressed on the loop circuit by the antenna is adjusted (by coupling and resistance) so as to be equal to that of the loop circuit. For this reason, the two emfs will add when the loop is pointed in one direction (toward the station to be received) and the received signal will be double that which could be obtained on either the antenna or loop alone. For all other positions of the loop the two emfs are out of phase and the result is that the strength of the signal is reduced, finally becoming zero when the loop has been rotated through 180° in either direction from the position at which maximum signal was received.

31-679. The intermediate circuit couples to both the loop circuit and the secondary circuit of the receiver, thereby passing on to the secondary circuit the resultant emf of the antenna-loop combination. Most of the selection in wave length takes place in this intermediate circuit. **Intermediate circuit.**

31-680. The secondary circuit of the receiver is tuned to the wave length to be received and the emf induced in it through the intermediate circuit coupling is passed on to the input (filament-grid) of the radio-frequency amplifier, modulated by the radio-frequency driver, and amplified through three stages, then detected by the detector tube. The resultant audio-frequency pulses are then amplified by two steps of audio-frequency amplification, and the selected signal heard in the telephones. **Secondary circuit.**

31-681. Static reduction is very pronounced when the model RB receiving equipment is used. (Maximum reduction of static and maximum received signal are obtained when the direction of static is diametrically opposite to that of the signal source.) **Static reduction.** Under these conditions static would be received on the null point of the system and therefore no static would be heard, while in the case of the signal the action of both the antenna and loop would combine resulting in the doubling of the signal. This condition is, however, seldom met in practice but a very marked diminution in the strength of static and considerable increase in signal audibility will result even when the direction of static and signal sources are separated by as small an angle as 40° .

PART 3.—DESCRIPTION.

31-682. A simplified diagram of the model RB receiving equipment is shown in figure 31-42. The complete equipment consists of the following units:

- (1) Antenna.
- (2) Loop (8 feet square with 48 turns spaced eleven-sixteenths inch apart).
- (3) 1 barrage unit, type SE 1793.
- (4) 1 receiver, type SE 1530.
- (5) 1 radio-audio-frequency amplifier, type SE 1617.
- (6) 1 radio-frequency driver, type SE 1603.

31-683. The antenna should be a single wire approximately 200 feet in length and from 50 to 100 feet in height. It may be stretched on a slant to some high point. **Antenna.**

31-684. The loop consists of 48 turns of No. 14 B. & S. size extra flexible wire, double braid and rubber covered, spaced eleven-sixteenths inch between turns on a form 8 feet square and 40 inches wide. The loop can be either fixed or rotatable. **Loop.**

31-685. The barrage tuning unit, type SE 1793, includes a loading and coupling inductance, a resistance variable in steps and a capacity consisting of a continuous variable air dielectric condenser plus three fixed condensers, that are cut in as necessary, for the antenna circuit. A switch is provided whereby the condenser can be thrown in series or in parallel with the antenna. A reversing switch allows the phase relation of the coupling **Barrage tuning unit.**

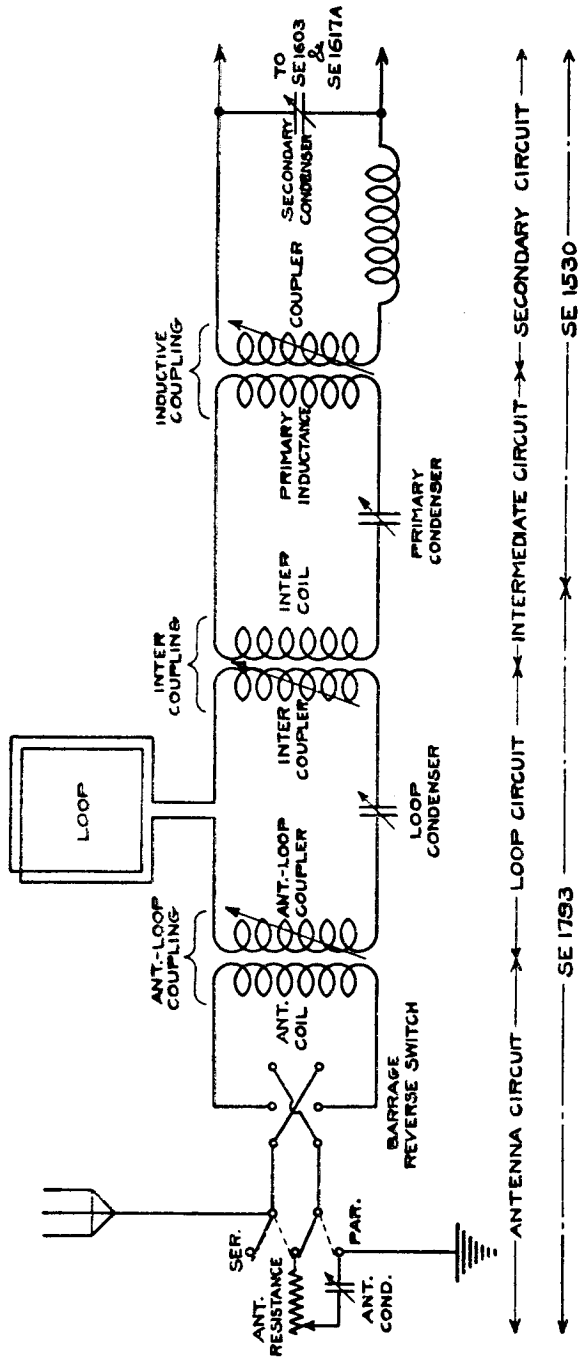

Fig. 31-42.—Simplified circuit of model RB receiving equipment.

between the antenna and loop circuits to be reversed. Binding posts are provided for the antenna and ground connections.

31-686. The loop circuit includes a coupling coil for coupling to the antenna circuit, a coupling coil for coupling to the intermediate circuit, and a capacity consisting of a continuously variable air dielectric condenser plus three fixed condensers which are cut in as necessary.

Loop circuit.

31-687. A coupling coil is also provided in this unit for coupling to the loop circuit, and connections are made from this coil to the primary circuit of the long-wave receiver, type SE 1530.

Coupling coil.

31-688. The long-wave receiver, type SE 1530, consists of the usual primary and secondary circuits found in all inductively coupled receivers except that the tuning is accomplished in each circuit by a continuously variable air dielectric condenser and three fixed condensers in conjunction with a fixed inductance, thereby making for low circuit resistance and high selectivity. The primary circuit is, however, a continuation of the intermediate circuit, the coupling coil of which to the loop circuit is in the "barrage tuning unit." The intermediate circuit is tuned by means of a condenser in the long-wave receiver and coupling to the secondary circuit is effected as shown in the diagram. Two leads are taken from the secondary circuit tuning condenser to binding posts to which is connected the radio-frequency driver, type SE 1603.

Long-wave receiver.

31-689. The radio-frequency driver, type SE 1603, follows the long wave receiver. This piece of apparatus is described in Section VI, D.

Radio-frequency driver.

31-690. The radio-audio-frequency amplifier, type SE 1617A is next. This amplifier is described in Section VI, B.

Radio - audio-frequency amplifier.

31-691. The several pieces of apparatus are supplied with suitable terminals for making the interconnections. Terminals of equal height are joined together by bus bars which are supplied with the equipment.

Connections.

PART 4.—OPERATION.

31-692. (1) Ease of operation of the model RB receiving equipment was the aim in the design of the apparatus and, although there are several circuits to be tuned and adjusted for best reception, the values of inductance and capacity are such that signals from the station to be received can be readily found.

General.

(2) Special operating features of the radio-frequency driver, type SE 1603, and the radio-audio-frequency amplifier, type SE 1617A, have been given before, therefore only those features that have to do with the operation of the equipment as a whole will be given here.

31-693. Figure 31-43 shows a front view of the panels of the apparatus included in the model RB receiving equipment. The various adjusting knobs are clearly shown and named in the figure in order that the various steps in the operation of the equipment may be easily followed. The following procedure should be adhered to when operating this equipment:

Operating procedure.

(1) Use loop for pick-up work (barrage reverse switch in center position).

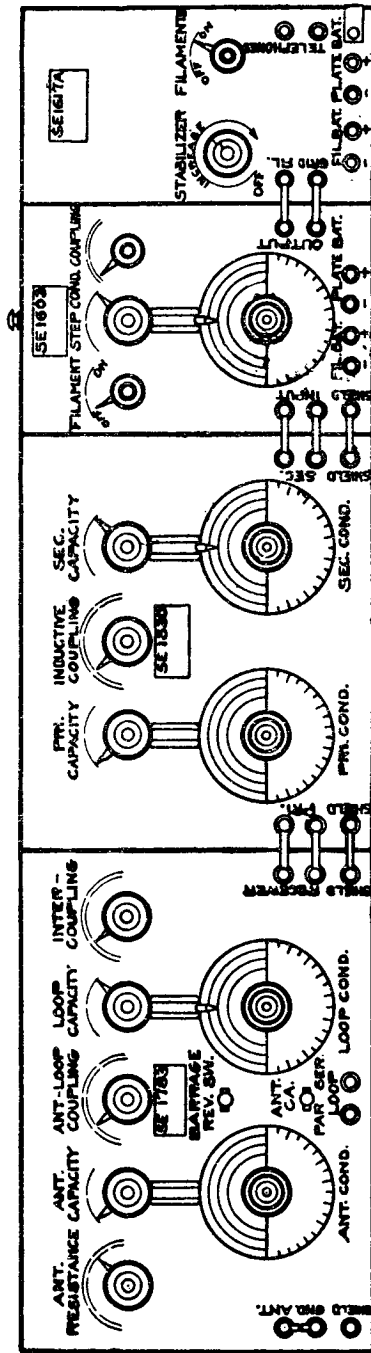

FIG. 31-43.—Model RB receiving equipment (panel view).

(2) Make sure that all connections are correct and tight. Check battery connections for proper polarity.

(3) Turn filament switches of SE 1603 and SE 1617A to "on" position.

(4) Set radio-frequency driver on approximately the wave length to be received. (The driver is calibrated in wave length to facilitate setting of condenser.) Set condenser of driver slightly off wave length to be received in order that a beat note may be heard.

(5) Set primary and secondary condensers of type SE 1530 receiver to the wave length to be received (calibration is provided on condenser dials).

(6) Set inductive coupling (intermediate-secondary circuit) on type SE 1530 receiver near maximum (100° to 150°). Zero coupling is at approximately 40° for the purpose of obtaining reverse coupling and passing through zero coupling.

(7) If a rotating loop is used, place plane of loop in line with the station to be received.

(8) Rotate loop condenser of type SE 1793 until maximum signal is received (this adjustment should be made with barrage reversing switch in center position, thus cutting the antenna out of circuit).

(9) If signal is not heard throw barrage reversing switch to either side, thus cutting the antenna into circuit. Cut out all antenna resistance and tune antenna circuit with antenna condenser. (A series-parallel switch is provided by means of which the antenna condenser is placed in series or in parallel with the antenna. Use series connection for wave lengths up to approximately 15,000 meters and the parallel connection for the longer wave lengths.)

(10) Final tuning should be done with the antenna out of circuit (barrage reversing switch in center position). The loop circuit should then be adjusted until maximum signal is heard with moderately loose coupling between the loop and intermediate circuits (intermediate coupling).

(11) When desired signal is heard throw barrage reversing switch to either side (this should increase strength of all signals and interference).

(12) Start cutting in antenna resistance with moderate coupling (100°) between antenna and loop (antenna-loop coupling). If signal is lost during this operation reverse position of the barrage reversing switch. When this switch is in the proper position, desired signal should be increased and the interfering signals reduced in strength.

Best results are obtained by making the receiving equipment inoperative in the direction from which the static comes.

The amount of antenna resistance will vary from day to day.

Interference can be reduced by careful adjustment throughout the equipment. No advantage is gained by the use of tight couplings.

Strong interfering signals can be reduced by decreasing the couplings.

If the directions of static and signal are not diametrically opposite, adjustment should be made to reduce the static by swinging the loop until the best signal-static ratio is obtained. If necessary, sacrifice some of the strength of signal to obtain this condition.

PART 5.—FAULTS AND REMEDIES.

No barrage effect. 31-694. If no barrage effect is obtained it may be due to any of the following causes:

- (1) Insulation of loop or antenna may be wet or otherwise faulty.
- (2) Ground connection to equipment may be too long.
- (3) Proper ratio of antenna-resistance to antenna-loop coupling is not being used.
- (4) Couplings throughout may be too close.
- (5) Antenna or loop may not be exactly in tune.
- (6) Amplifier batteries may be causing noise.
- (7) Amplifier tubes may be noisy.

Howling of amplifier. 31-695. Howling of amplifier may be caused by—

- (1) Defective shielding.
- (2) Shield lead of shielded telephone cords open or not connected to shield clamp.

Fading effect. 31-696. (1) Fading of signals or static, when separate batteries are used for the R. F. driver and amplifier, may be caused by—

- (1) Exhausted amplifier batteries.
- (2) Exhausted radio-frequency driver batteries. (Batteries should not be used until completely exhausted.)
- (3) Long distance transmission, especially noticeable on summer afternoons. (There is no remedy except rotating the loop slightly which sometimes helps.)

Signal only stops. (2) If signal suddenly stops and static seems to increase it is an indication that the filament battery of the radio-frequency driver is run down.

Signal and static die out. (3) If both signals and static fall off in intensity the trouble is due to exhaustion of the amplifier filament battery.

NOTE.—This apparatus is so arranged that common batteries can ordinarily be used, one for the filament supply and another for the plate circuit supply of the R. F. driver and amplifier. In this case a renewal of batteries will be necessary should any of the faults just mentioned arise.

Loud hissing. 31-697. If loud hissing is heard the trouble is due to—

- (1) Improper adjustment of the radio-frequency driver coupling.
- (2) Poor adjustment of stabilizer on amplifier.
- (3) If loud hissing can not be stopped by correcting for (1) and (2) the trouble is due to amplifier tubes. These should be changed about or renewed to obtain a quiet amplifier.

Grounding shields of apparatus. 31-698. The shields of the R. F. driver and the amplifier are connected internally to the +filament battery binding post, thus bringing them to a potential of approximately 6 volts. In the lower left-hand corner of the R. F. driver and in both lower corners of the receiver and the barrage tuning unit the shield bind-

ing posts are provided with connecting links, thereby establishing the shielding of the entire equipment at a potential equal to that of the +filament battery. A removable link is also supplied on the lower left shield binding post of the barrage tuning unit for connecting to the ground terminal. This connection to ground should normally be left open but, if trouble is experienced, make this ground connection after making certain that a short circuit will not occur on either the filament or plate circuit supply.

(3) *The Tuned Telephone.*

PART 1.—GENERAL.

31-725. The tuned telephone circuit provides a means for tuning at audio frequencies and should not be confused with the ordinary radio-frequency tuning provided by coupled circuits, rejectors, and the like. Its purpose is to prevent undesired signals, which vary in audio frequency from that of the desired signal, from passing through the telephones. On this account it is particularly adapted to the reception of continuous wave signals by the "beat" method. It is of less value for the reception of spark signals for the reason that the frequencies of practically all Navy spark transmitters lie within the 450-550 cycle zone. Further, the tuned telephone does not effectively separate signals whose frequencies vary by only a few cycles because the tuning is quite broad on account of the resistance, etc., of the circuit.

Purpose and use.

31-726. The tuned telephone circuit has been incorporated in the type SE 3552 tuned telephone for use in the model E receiving booth, in conjunction with the type SE 3649 receiver.

Application.

PART 2.—THEORY.

31-727. (1) The tuned telephone is an acceptor circuit in that it is actually tuned to resonance with the frequency desired. In the resonant condition it has no reactance and the only resistance is that due to the circulating resistance, therefore any signal having the same audio frequency as that to which the tuned telephone circuit is resonant will be heard and any other signals having an audio frequency differing from that to which the circuit is resonant will not be heard.

Selection by audio-frequency tuning.

(2) For example, suppose that it is desired to receive a station transmitting on 10,000 meters, frequency 30,000 cycles, with a "beat" note of 1,000. The secondary of the receiver would be tuned to either 29,000 cycles or 31,000 cycles. Assume that the secondary circuit is tuned to 29,000 cycles, and that another station transmitting on a wave length of 11,000 meters is interfering, with a signal of approximately the same intensity as that to be received. The signals from the interfering station beating with the local oscillations will result in the signal having a note of 1,728 cycles, which is within the audible range and would be disturbing. Now if the tuned telephone is cut into circuit and adjusted to be resonant to 1,000 cycles the interfering signal will either disappear or be greatly reduced in intensity. The tuned

telephone, therefore, gives selection in wave length by audio-frequency tuning.

(3) The intensity of static can also be greatly reduced if the tuned telephone is used and the note of the received signal increased to a frequency of approximately 1,500 cycles, or more.

PART 3.—DESCRIPTION.

Elements of circuit.

31-728. A simplified drawing of a tuned telephone circuit is shown in figure 31-44. The tuned telephone circuit consists of three parts:

- (1) Telephone.
- (2) Condenser.
- (3) A large inductance.

This circuit is connected between the negative filament and plate of the receiving vacuum tube.

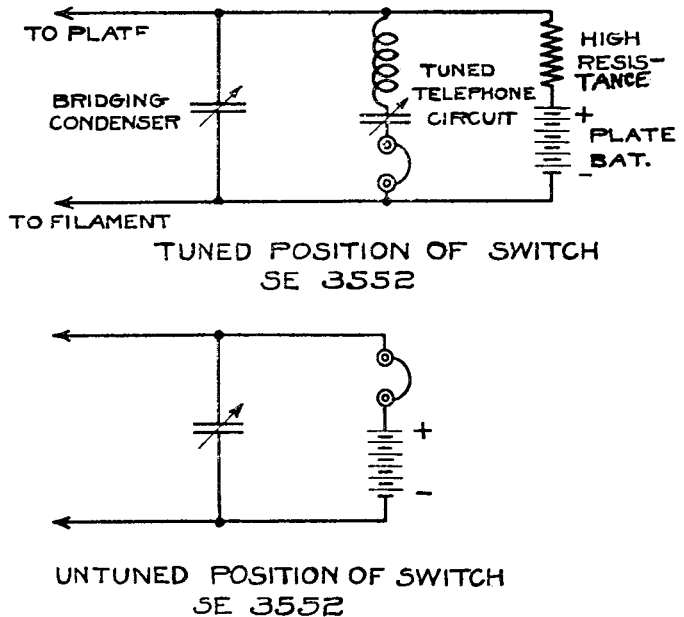

Fig. 31-44.—Tuned telephone circuit connections.

Telephones. 31-729. The telephones are changed from their usual position in series with the plate battery to a series connection with the tuned telephone circuit, and at the same time a high resistance is substituted in the first circuit in place of the telephone to prevent the value of the plate current from being changed due to the transfer of the telephones from that circuit.

Condenser. 31-730. The condenser is of the continuously variable air dielectric type with a maximum capacity of 0.0025 μf .

Inductance. 31-731. The inductance consists of 22,000 turns of No. 34 B. & S., D.S.C. copper wire wound on an iron core. The frequency of the tuned telephone circuit can be adjusted by means of the condenser to practically any audio frequency.

31-732. The transfer switch type SE 3551 is provided for cutting the tuned telephone out of circuit. When the switch is thrown to the left ("tuned") the tuned telephone is cut into circuit and when it is thrown to the right ("untuned") the tuned telephone is cut out of circuit and the regular receiving arrangement is used. Transfer switch.

PART 4.—OPERATION.

31-733. The tuned telephone should be used only when interfering signals make the reading of the desired signal uncertain and also when static is troublesome. *The tuned telephone should never be used in stand-by or pick-up work for the reason that every change in the wave length of the secondary circuit while receiving CW signals will change the audio frequency of the note, thereby throwing the tuned telephone out of resonance and thus probably preventing the signal from being heard.* When to be used.

31-734. (1) The following procedure should be used when using the tuned telephone: Tuning procedure.

(a) Throw type SE 3551 switch to left.

(b) Vary the setting of the tuned telephone condenser slightly until undesired signals are lost and the desired signal is brought to maximum intensity.

(2) It should be remembered that the radio-frequency tuning is to be performed in the usual manner and that the tuned telephone is solely an audio-frequency tuning device. For this reason select the "beat" note by varying the secondary circuit condenser *before* changing over to the tuned telephone.

PART 5.—FAULTS AND REMEDIES.

31-735. Best reception of continuous wave signals by either the autodyne or heterodyne method is obtained when the strength of the local oscillation bears a certain relation to the strength of the incoming oscillations. This generally calls for a critical setting of the back coupling (the loosest coupling possible). Under these conditions the secondary circuit is likely to stop oscillating when the tuned telephone is cut in. The remedy is to increase the back coupling. Oscillations stop.

31-736. Failure of the tuned telephone to suppress undesired signals is caused by insufficient separation between the "beat" note of the desired and undesired signal. This can sometimes be remedied by obtaining a higher beat note or by tuning for a new beat note of the desired signal on the other side of resonance. Failure to suppress interference.

31-737. Failure to suppress static is generally due to the employment of an insufficiently high beat note. In this case the beat note should be increased in frequency as much as may be necessary to produce results. Failure to suppress static.

(F) WAVEMETERS.

PART 1.—GENERAL.

31-750. The wavemeter is an instrument used primarily to measure the wave length of a transmitter, the wave length being expressed in meters. A secondary use of the wavemeter is in the Purpose.

measurement of the decrement of modulated waves and when equipped for this purpose is called a decremeter.

Essential circuit.

31-751. The wavemeter consists essentially of an inductance and capacity in series and some type of indicating device. The inductance consists usually of a set of coils having different values of inductance while the capacity is of the continuously variable condenser type. The wave length range of the wavemeter is obtained by the combination of the variable condenser and the several coils, the inductance of the latter being adjusted so that a considerable overlap in wave length exists between successive coils.

Resonance indicating devices.

31-752. (1) The indicating instrument is usually a current squared meter (thermogalvanometer) which is connected in series with the inductance and capacity. The meter now used in service wavemeters is of the thermal type. Another type of indicating device has a low candle power, low voltage incandescent bulb which is connected in series with the wavemeter circuit. The filament of the bulb is brought to a dull red glow by means of a dry battery; thus a very small extra current is able to bring the filament up to normal brightness and the sensitivity of the device is thereby greatly increased.

(2) Either of the indicating devices just mentioned is used when the wave length of a transmitter is to be measured. The transmitter may be either spark or CW. Another device is the crystal detector and telephones and can be used when measuring the wave length of spark, telephone, and ICW transmitters.

Indication of resonance.

31-753. The inductance and capacity of the wavemeter constitute an oscillatory circuit and this circuit will respond most energetically to a transmitter when the circuit is in resonance with the transmitter, resonance being detected by means of the indicating device used. In the case of the current squared meter resonance is indicated when maximum deflection is obtained, with the incandescent bulb when the filament is brightest, and with the detector and telephones when the signal is loudest. The wave length of the transmitter corresponds to that of the wavemeter when resonance is obtained with the wavemeter. The wave length can then be read directly from the engraved scale or from the wave length curves supplied with the wavemeter, in accordance with the wavemeter coil used and the setting of the condenser in degrees.

Decremeter.

31-754. The decremeter measures the decrement as well as the wave length of the transmitter and the indicating device is always a current squared meter. The decremeter is tuned to resonance with the transmitter in the usual manner and the deflection of the current squared meter and the setting of condenser noted. The condenser is then rotated in either direction until the deflection falls to one-half that obtained at resonance and the decrement dial is then locked with its zero on the reference line. The condenser is again rotated from the one-half deflection point through resonance and to the other one-half deflection point always moving in the same direction. The reading of the decrement dial opposite the reference line is the decrement of the transmitter plus that of the decremeter. Subtract the decrement

of the instrument from the reading of the decrement dial and the result is the decrement of the transmitter.)

31-755. The wavemeter can also be used as a low-power driver for exciting the circuit under observation. A buzzer connected into the wavemeter circuit is used for this purpose. This feature is especially valuable for tuning receiving circuits to the specified wave lengths. Wavemeter
used as driver.

31-756. (1) Service wavemeters are used for all-around practical purposes, and, being portable, are likely to be injured or their calibration disturbed. It is essential, therefore, that they be handled carefully and only by experienced personnel. Service wave-
meters.

(2) Service wavemeters contain the essential parts of the wavemeter in one box arranged in a compact and practical manner. These wavemeters are ruggedly constructed and are suited to the work for which they were designed. The following table gives the various types and wave length ranges of the service wavemeters now in use: Types of serv-
ice wavemeter.

Type No.	Wave-length range.	Indicating device.
SE 73.....	100-3,000	1 2 meter and detector.
CN 259.....	85-5,000	Do.
SE 392.....	150-2,400	Do.
SE 871.....	100-3,000	Do.
SE 1073.....	100-20,000	Do.
SE 1402.....	50-1,000	Do.
SE 1419.....	150-2,500	Do.
SE 1740.....	150-3,000	Do.
SE 3626.....	300-2,500	Crystal detector.
SE 3644.....	300-2,500	Do.

31-757. (1) In addition to the service wavemeters there are three other classes of wavemeters: Standard wave-
meters.

- (a) Primary standard wavemeters.
- (b) Secondary standard wavemeters.
- (c) Tertiary standard wavemeters.

(2) The *primary standard wavemeters* are located at the Naval Radio Research Laboratory, Bureau of Standards, Washington, D. C., and Radio Laboratory, navy yard, Mare Island. These are special wavemeters associated with the multivibrator and constitute the absolute wave length standards to which all other wavemeters are adjusted.

(3-a) *Secondary standard wavemeters* are located at navy yards, Boston, New York, Philadelphia, Norfolk, Mare Island, and Puget Sound and on the flagships of the Atlantic and Pacific fleets. These wavemeters cover the entire wave length range (100 to 50,000 meters) in fixed steps and have been compared with a primary standard wavemeter.

(3-b) The secondary standard wavemeter consists of the wavemeter and a driver and is used for calibrating tertiary standard and service wavemeters.

(4) The *tertiary standard wavemeters* have been selected from types SE-392, SE-1402, and SE-1073 wavemeters and have been carefully calibrated. These wavemeters are located at the navy yards, Portsmouth, Boston, New York, Philadelphia, Norfolk, Charleston, Key West, New Orleans, Great Lakes, Mare Island,

Puget Sound, and Pearl Harbor and on the fleet flagships and fleet repair ships of the Atlantic and Pacific fleets.

(5) *None of the standard wavemeters should be used for tuning purposes as they are intended as standards by which service wavemeters may be frequently checked for tuning and other purposes.*

(6) The system of wavemeters just outlined is for the purpose of maintaining all ship and shore transmitting stations of the Naval Communication Service on their assigned wave lengths in order that interference due to stations being off wave length may be eliminated.

PART 2.—DESCRIPTION.

Wave length range. 31-759. The SE 1073 wavemeter has a wave length range of 100 to 20,000 meters. The condenser is arranged so that the wave lengths can be read directly, no curves being supplied with the instrument.

Condenser 31-760. The condenser is of special construction, both sets of plates being movable and actuated through special gearing by turning a knob situated on the face of the wavemeter. The condenser has a cylindrical shield which is fitted with a graduated sheet of paper on which are marked the degrees, wave lengths, and capacity for every even numbered degree setting. The figures are read through a window across the length of which are etched two lines spaced a distance equal to that of one degree on the condenser sheet. However, *only the lower line should be used as the reference line.* On the beveled edge of window frame are marked horizontally headings for the columns of figures appearing on the condenser sheet. These headings are:

Capacity in $\mu\mu\text{f}$.

Coil No. 1, etc.

Inductance. 31-761. The inductance is wound on five forms, but there are actually six coils, Nos. 1 and 2 being on one form. The inductances are plugged into a special jack supplied for making contact with the wavemeter circuit.

Indicating device. 31-762. The indicating device is in series with the wavemeter circuit and is of the thermogalvanometer type and is generally used when finding the wave length of a transmitter. A detector is also supplied for spark, telephone, and ICW work or whenever the power of the transmitter (modulated transmission) is not sufficient to actuate the meter. The detector can also be used when it is desired to listen to the note of the transmitter (modulated transmission).

PART 3.—OPERATION.

Determination of wave length of transmitter. 31-763. (1) The wave length of a transmitter is found as follows:

(a) Set the wavemeter so that its coil is coupled to the circuit to be measured.

(b) Select the coil that will give the wave length desired.

(c) Set wavemeter condenser on zero and start up transmitter.

(d) Vary wavemeter condenser slowly and continuously in one direction until a deflection shows on meter.

(e) Loosen wavemeter coupling if coupling appears too tight (as indicated by deflection of meter) and find resonance.

(f) Read wave length corresponding to wavemeter setting to find wave length of transmitter. (The upper line on the glass window should not be used, the lower line being the reference line.)

(2) (Care should be taken that the coupling is only to the circuit under measurement and that the coupling is not too tight because the thermogalvanometer is easily burned out. It is not necessary to obtain full scale deflection except when searching for harmonics or humps, in which case fairly tight coupling is sometimes necessary, especially for points other than that for resonance with the main wave. A deflection of 20 at resonance is sufficient for all ordinary wave-length measurements.)

31-764. The above applies to large transmitters, but when using a 5 or 10 watt driver for comparing wavemeters the wavemeter coupling must be kept as loose as possible because service wavemeters have a high radio-frequency resistance and, therefore, will abstract a considerable percentage of the power available in the driver when tuned to resonance. Under these circumstances the wavemeter will "drag" the driver and erroneous observations will result. Use with low-power transmitters.

31-765. Wave lengths as measured by the wavemeter using the detector and telephone will not agree with those measured when using the thermogalvanometer. This is caused by the addition of a considerable amount of capacity due to the detector. The capacity effect of the detector is more pronounced at the lower settings of the condenser and the actual wave length will be greater than that indicated on the condenser scale. Use of detector and telephones.

31-766. (1) To use the wavemeter as a driver connect one or two dry-cell batteries to the proper terminals on the wavemeter and throw the buzzer switch to the "on" position. Adjust buzzer to give clear note and couple wavemeter to the circuit under test. A detector and telephones connected to the latter circuit will be necessary to detect resonance. Wavemeter used as driver.

(2) (The buzzer adds considerable capacity to the wavemeter circuit.) The wave lengths will therefore be slightly higher than those indicated on the wavemeter, especially at low settings of the condenser.

PART 4.—FAULTS AND REMEDIES.

31-767. The wavemeter is an instrument of precision and is somewhat delicate in construction. The wavemeter should, therefore, not be handled roughly. To be carefully handled.

31-768. No changes whatever should be made in the wavemeter circuit because the calibration will be affected. Should it be necessary to change the wavemeter it should be done by an experienced man and the wavemeter recalibrated and new wave length curves drawn. Although Service wavemeters are ruggedly constructed, the condenser is liable to damage due to rough handling of the wavemeter. The wavemeter should never be picked up nor moved about by the condenser handle. The wavemeter should not be moved by sliding it on the table nor should it be set down violently. Making changes in wavemeter.

31-769. The thermogalvanometer is responsible for most of the trouble experienced with wavemeters. The element of the meter Thermogalvanometer.

is easily burned out, in which event the instrument will not indicate. If the needle sticks resonance cannot be detected. Re-
placement of the thermogalvanometer then becomes necessary.

Defective plug contacts.

31-770. Frequently the contacts made by the plug of the coil are defective, being either loose or open. This will result in erratic behavior of the thermogalvanometer. The remedy is to repair the jack.

Open circuit in coil.

31-771. Broken connection from the coil to the plug is indicated by the failure of the thermogalvanometer to deflect whenever that coil is used. The connection to the plug should be remade, care being taken not to remove any turns from the coil itself because this will affect the calibration of the wavemeter for that coil.

Defects in condenser.

31-772. (A short circuit in the condenser is another frequent fault and is caused by one of the fixed plates touching one of the movable plates at some setting of the condenser.) This is detected by a sudden drop in deflection of the thermo galvanometer when the plates touch or the rubbing can be heard directly when the condenser is revolved. The position of the short circuit can be located by a pair of telephones and a dry battery connected in series across the terminals of the condenser. When this method is used care must be taken not to include the thermogalvanometer in the battery circuit because the meter will be injured. The defective condenser plate should be straightened, but as this will change the calibration of the wavemeter, it should be checked by a standard wavemeter after repairing.

(G) MISCELLANEOUS APPARATUS.

PART 1.—TELEPHONES.

Purpose.

31-800. Telephones are used in radio for the purpose of converting into sound waves the received electrical pulses emitted by the transmitter. The telephone method of reception is at the present time the simplest, the most rugged, and, in general, the most satisfactory and efficient.

**Types of tele-
phones.**

31-801. Two types of telephones are now used in the service. They are: Types CW 834 and CAB 160. The first type employs permanent magnets, windings, and diaphragm of the usual construction. The second type is entirely different in construction in that a "pony" diaphragm hinged on one side and equipped with a small bar is set between the pole faces of the permanent magnet. The vibration of the "pony" diaphragm is transmitted by the bar to the main diaphragm, which is a circular piece of thin mica.

Description.

31-802. The usual type of telephone is resonant to a frequency in the neighborhood of 1,000 and will, therefore, be most sensitive when the frequency of the direct-current pulses has the same value. The telephones consist of two ear pieces connected in series, both ear pieces being the same in construction. The telephone consists of a permanent magnet, generally U shaped on each limb of which is a winding consisting of many turns of very fine copper wire. The two windings are connected so that the effect of the current flowing through them on the permanent magnet will be in the same direction. A thin enameled iron dia-

phragm is held in place very close to the pole tips of the permanent magnet and the whole assembly incased in a suitable ear piece.

31-S03. The action is as follows: The permanent magnets hold the diaphragm in a set position. When a very minute pulse of direct current passes through the winding it will either add to or subtract from the total magnetism of the permanent magnets and displace the diaphragm from its normal position. The movement of the diaphragm sets up a wave in the air which is heard as a sound by the ear. Permanent magnets are used because a very small current is required to change the amount of magnetism of an already magnetized piece of steel, whereas a very considerable amount of current would be required to give the same effect were the pole pieces not partially magnetized.

Theory.

31-S04. The telephones are connected to the binding posts on the receiver or amplifier marked "telephones." The connections should be made tight and the cord stopper used to prevent any undue strain being put on the telephone cord tips. Whenever the shielded type of telephone cord, type SE 1699, is used, the tip end of the shielding should be connected to the shield of the amplifier by the lug supplied with the cord, while the telephone receiver ends of the cord shield should be connected to the telephone receiver casings by the lugs supplied for the purpose. The type CW 834 telephones are provided with a small screw by which the lug can be secured to the casing.

Operation.

31-S05. (1) Telephones are quite delicate in construction and should not be handled roughly, such as throwing them down on the desk, dropping them, or allowing them to strike together violently when removing them from the head. The telephone cords should be stoppered at each of the ear pieces and at the telephone cord tips to prevent breakage at the tips. The telephone cords should be kept dry at all times, as they will become inoperative when damp.

Faults and remedies.

General care.

(2) The diaphragms should be kept clean and dry and held securely in place by the cap. After the telephones have been worn for a considerable length of time they become rusted, due to perspiration. The heavily enameled side should be placed toward the ear. If the enamel blisters, it should be scraped off and an extremely thin film of vaseline applied to prevent rust. The diaphragms should not be bent, because a bent diaphragm reduces the sensitivity of the telephones and in addition is likely to stick. A sticking diaphragm is sometimes remedied by turning the diaphragm side for side. Frequently one earpiece is more sensitive than the other or is inoperative. This is generally due to a faulty diaphragm. The diaphragm should be turned or replaced.

The diaphragm.

(3) Since the windings of the two earpieces are in series, a break in one renders both earpieces inoperative. Burned out windings or broken connections can be located by a Wheatstone bridge. An open circuit can be readily detected by means of a dry battery. If a loud clicking sound is not heard when the telephone cord terminals are connected to the dry cell, it is an indication that the telephones are open circuited. The usual fault occurring in the telephones is a broken connection to the telephone

Open circuits.

cord tips. Consequently whenever the telephones test open circuit, the tip connection should be carefully inspected.

PART 2.—CRYSTAL DETECTORS.

Purpose. 31-806. The crystal detector was formerly used instead of the vacuum tube for the detection of all types of radio signals. Since the development of the vacuum tube the crystal detector has been used but very little.

Types of detectors. 31-807. The following detector stands are now in use:

Type No.	Number of stands.	Crystals used.
SE 183.....	3	Carborundum, galena, and silicon.
SE 184.....	1	Galena.
CR 1235.....	1	Silicon with micrometer adjustment.

Theory. 31-808. The crystal detector consists of two elements and its action depends on the unilateral conductivity of the crystal used. It acts like a check valve in the radio circuit, allowing the current to flow through it readily in one direction and practically preventing a current flow in the opposite direction. The current pulses that pass through the detector charge the telephone condenser, which, in turn, discharges through the telephones. By this operation the groups of radio-frequency oscillations received from the condenser of the secondary circuit are changed into audio-frequency pulses. The sensitivity of a good crystal detector (galena) is equal or slightly superior to that of a vacuum tube.

Operation. 31-809. The detector stand, whether single or triple, is provided with two binding posts, by which it is connected to the secondary circuit of the receiver. Audio-frequency amplification can be used with the crystal detector, the amplifier being connected to the telephone binding posts of the receiver. A multi-point switch is provided for the triple stand detector, permitting any detector on the stand to be used. The carborundum requires a slight direct-current voltage applied to it in order that the point of detection may be varied and the sensitivity of the detector thereby increased. The other types of detectors do not require additional voltage.

Faults and remedies. 31-810. (1) Failure of the crystal detector to operate is usually due to lack of proper contact between the two elements of the detector. A sensitive point can be found by varying the point of contact of the elements while listening to the signal received from the test buzzer in the receiving set, or to an incoming signal or static. The sensitivity of the contact should be tested from time to time, in the absence of signals, by means of the test buzzer. Heavy crashes of static or very loud signals will decrease the sensitivity of the contact. A second and less sensitive but more rugged detector should be used when it is expected to receive near-by and strong signals. The carborundum detector is suitable for this kind of work while the galena and silicon are somewhat more sensitive, but more easily thrown out of adjustment by vibration, strong signals, or heavy static.

(2) The crystals should be kept clean and dry, and when the metal point is used it should be kept sharp, clean, and bright.

PART 3.—VACUUM TUBES.

31-811. Vacuum tubes are now in general use for all receiving purposes. They are used in all vacuum tube detectors, audio-frequency and radio-audio-frequency amplifiers and radio-frequency drivers. The type SE 1444 and CW 933 vacuum tubes are now in use. They are equipped with the same type of base so that they may be interchangeable. However, *only the specified type of tube can be used* in most of the receiving apparatus. The apparatus equipped with the SE 1719 ballast lamp in place of the filament rheostat uses only the SE 1444 vacuum tube. The type CW 933 vacuum tube is not used in any radio-audio-frequency amplifier.

General.

31-812. (1) Both types of tubes can be used as detectors; the type SE 1444 being considered somewhat more sensitive and has the additional advantage that it takes about three-fifths as much current as the type CW 933. The latter type can be used interchangeably with the SE 1444 in the 2-stage audio-frequency amplifiers.

Operation.

(2) The proper adjustment of filament current is of vital importance in the operation of any tube. The tube becomes a better oscillator with a slight increase of the filament current above the normal flow, but the detector qualities of the tube are not always improved by an increase of the filament current. The following table gives the normal filament current for both types of tubes:

Adjustment of filament current.

Vacuum tube.	Filament current (ampere).
SE 1444.....	0.65
CW 933.....	1.1

The filament of the SE 1444 is made of tungsten and burns at a very high temperature. If the current is increased to 0.70 ampere the life of the filament is greatly reduced. The filament of the type CW 933 vacuum tube is made of platinum coated with an oxide of rare earth. The temperature of this type of filament is very much lower than that of the tungsten type and the electron emission is greater than that required for a plate voltage of 40 volts. Therefore, no advantage whatsoever is gained by increasing the temperature of this filament above the normal value. *Do not at any time unduly increase the filament current, as it will weaken the signal and greatly shorten the life of the tube.*

(3-a) The value of the plate voltage is second in importance only to that of the filament current and is governed by similar considerations. An increase in the plate voltage, in general, improves the tube as an oscillator. The following table gives the proper plate voltage to use for detection and amplification for the two types of tubes:

Proper plate voltage.

Vacuum tube.	Plate voltage.	
	As de- tector.	As am- plifier.
SE 1444.....	40	40
CW 933.....	40	40

(3-*b*) The radio-audio-frequency amplifiers require approximately 60 volts (3 type SE 3535A batteries in series) for the plate supply, otherwise they are likely to howl.

Faults and remedies.

31-813. The vacuum tube is quite delicate in construction, the filament especially being liable to breakage due to rough handling. Undue twisting of the tube while placing it in a socket is likely to loosen the glass bulb from the base. The base should be kept clean and dry to prevent leakage between the projecting points across the insulating compound. Leakage in the base or in the socket will cause erratic behavior of the tube. The presence of "blue glow" in the tube is an indication that gas is present and that the tube is "soft." No "blue glow" should appear but, if present, the plate voltage should be decreased until it disappears. If, under these conditions, the tube fails to operate satisfactorily, it is defective and should be replaced.

Filament current control.

31-814. (1) Vacuum tube equipment not supplied with the ballast lamps have rheostats for controlling the filament current. The purpose of the rheostat is to allow the filament current to be adjusted to the proper value and to compensate for a drop in voltage of the filament battery. A new filament battery should be cut into circuit when it is necessary to cut out all resistance in the rheostat to obtain proper operation of the apparatus. This is especially true with the Edison type of battery which has a falling voltage characteristic.

(2) Instead of burning the filament at an abnormal temperature look for a run-down plate battery.

(3) *Always turn the rheostats to the "off" position before cutting in a fresh filament battery.* This will prevent the filament from being burned out.

The ballast lamp.

31-815. The type SE 1719 ballast lamp is supplied on apparatus in place of the rheostat for the purpose of maintaining the filament current of the SE 1444 tube constant during a fairly large change in the voltage of the filament current supply and will take care of the voltage drop in the Edison type of battery. However, as soon as the filament current falls to a value below 0.65 the ballast lamp no longer controls the current flow and the current will drop until the tube fails to function. The remedy is to replace the battery by a freshly charged one.

PART 4.—CONDENSERS.

Purpose.

31-816. Condensers of various sizes are supplied as separate units to extend the range of a given receiver or for other special work. These condensers are always of the continuously variable air dielectric type.

Types.

31-817. The following sizes are now in use:

Type No.	Maximum capacity (microfarad).
SE 61.....	0.001
SE 62.....	0.0025
SE 63.....	0.005
SE 1741.....	0.0025

31-818. The capacity curve of this type of condenser is practically a straight line between 30° and 160°. They are well constructed, rugged, and have low dielectric losses. They are provided with stops at zero and 180° and are equipped with two binding posts for connecting them into circuit. Capacity curve.

31-819. (1) Service condensers are ruggedly constructed, but should never be lifted by the knob. They should be handled carefully, as otherwise the plates may be thrown out of alignment, thereby causing a short circuit between the movable and fixed plates and rendering the condenser inoperative. Faults and remedies.

(2) A condenser in good condition should test open circuit on direct current and should stand approximately 300 volts without the insulation breaking down.

31-820. Failure of a condenser to operate properly is indicated when a change in the setting of the condenser does not affect the circuit into which it has been connected or when, as soon as the condenser is cut in, no results can be obtained for any setting of the condenser. This may be caused by a broken connection to the plates of the condenser. The break may be between the circuit and the terminals or inside the condenser itself between either terminal and the set of plates to which it should be connected, or the condenser may be short-circuited. A short-circuit is usually located at only one point on the condenser scale unless the entire movable section of the condenser has dropped on to the fixed section, in which case the condenser will be short-circuited at all settings. An open circuit can be detected by the use of a pair of telephones and a dry cell connected in series. A loud click should be heard in the phones when a connection is made from one terminal to the pointer for the movable section and from the other terminal to the casing or to the fixed section. If the click is not heard the lead is broken in the condenser. A short circuit is located by connecting the telephone and dry cell across the terminals of the condenser and rotating the condenser slowly. If the fixed and movable plates touch at any point a loud click will be heard. The remedy is to straighten the plates. Failure of condenser.

PART 5.—INDUCTANCES.

31-821. Inductances in the form of loading coils are supplied to the service for use in connection with receiving sets to increase their range and for building special radio circuits. Purpose.

Types.

31-822. (1) Inductances are supplied in the following sizes:

Type No.	Inductance (mh).	Kind.
SE 205.....	14	Bank wound with taps.
SE 304.....	30	Spool wound.
SE 1567.....	10	Do.
SE 1568.....	20	Do.
SE 1569.....	40	Do.
SE 1666.....	5	Do.

(2) The coils are supplied with suitable terminals for connecting them into circuit. They are wound with litzendraht 3×16× No. 38 B. & S. enameled copper wire.

Faults and Remedies.

31-823. (1) The usual fault occurring in inductances is open circuit, and is indicated when no results can be obtained after the coil has been connected into the circuit. The open circuit can be verified by the use of a Wheatstone bridge which will read infinity. The break is usually found next to the terminal.

(2) A high resistance coil is indicated by the necessity for closer coupling. Such a coil can be tested on a Wheatstone bridge and if the resistance is much higher than the normal value it indicates a loose or poor connection between the winding and the terminals or that strands in the litzendraht are broken. The coil should be rewound with good wire if the high resistance is found to be due to defective wire.

SECTION VII.—BATTERIES.

PART 1.—GENERAL.

Purpose.

31-850. (1) Batteries are used, in general, for two purposes in the Naval Communication Service:

(a) In connection with vacuum tube equipment.

(b) For emergency power supply for transmitters.

Receiving vacuum tube supply.

(2) The dry cell and storage battery are both used in connection with vacuum tube receiving equipment. The filament circuit is always supplied by a storage battery because a larger current than can be supplied by the dry cell is required. For the plate circuit where the voltage is relatively high and the current of the order of a few milliamperes either the dry-cell or a special storage battery can be used. In practice, the type SE 3535A dry battery or the Edison "B" battery is used for this purpose.

Emergency power supply.

(3) The emergency power supply for transmitters is always obtained from storage batteries because the current demand is much greater than can be supplied by the dry cell. The storage battery is frequently used for the filament supply for vacuum tube transmitters.

PART 2.—THE TYPE SE 3535A DRY BATTERY.

Description.

31-851. (1) The type SE 3535A dry battery has been developed especially for use as the plate voltage supply of receiving vacuum tube equipment. It has a rated voltage, when new, of 22.5 volts and will deliver a current of approximately 4.3 milliamperes over a period of 34 days before the voltage is reduced to 17 volts.

measurements being made by a voltmeter across the terminals of the battery while it is discharging at approximately the normal rate. The average discharge voltage is 19.2 volts. The internal resistance is 315 ohms and the ampere-hour capacity 3.54.

(2) The battery is hermetically sealed and water proof. Three leads are brought out from the case, one from each end and one from the middle. The positive lead is red and is further designated by a plus sign stamped in the compound near the lead. When one-half the battery is used (either end lead and the center lead) the lead in the center becomes negative or positive according as the positive or negative end lead is used for the other lead.

31-852. These batteries have a low rate of deterioration on the shelf and are, in this respect, greatly superior to other types of dry batteries. Batteries held in stock over a year have proved to be in excellent condition when put into service, but it is not wise to carry a quantity in stock for a longer period than is required to meet the demands of the service. Frequent small shipments from the central supply depot are preferable to less frequent shipments of large quantities. Life of battery.

31-853. The SE 3535A battery will supply sufficient current for the plate circuit of any piece of receiving apparatus including the multi-stage amplifier and will function properly and efficiently on the latter for at least one month. When used with apparatus which employs only a few vacuum tubes, such as a vacuum tube detector or a detector tube and one 2-stage amplifier, the current drawn from the battery is less and its life prolonged in proportion. Intermittent duty also prolongs the life since only the actual ampere-hours used are to be deducted from the total ampere-hours available in the battery. Operation.

31-854. It is important that the batteries be used in order of their receipt, that is, the oldest first, so that those held in stock will be reliable. *This battery should not be tested by shorting* because this will appreciably reduce its life on account of the small size of the cells. The proper method of testing is to put the battery in service and read the voltage by a voltmeter connected across the battery terminals while the battery is discharging. If up to standard, repeat after approximately 1,000 tube-hours use, which is equal to continuous service on a 6-stage amplifier for one week. If the voltage is then less than 20 volts the battery is poor and should be renewed as soon as unsatisfactory results are obtained from it. The voltage under the condition noted, namely, after 1,000 tube-hours use, should be approximately 20.5 volts. A 6-stage amplifier draws a current of approximately 4.3 milliamperes from the battery. Tests.

31-855. Defective or run down batteries are indicated when the filaments of the tubes must be burned above normal brilliancy, when the back coupling must be tightened more than the usual amount, or both, and when the amplifier or detector circuit becomes erratic in its behavior and a frying or hissing tone or noise is heard in the telephones. The hissing or frying noises may also be caused by a poor contact or defective tube but it is generally an indication that the battery is exhausted. As soon as it has Faults and remedies.

been definitely determined that a battery is exhausted it should be replaced by a fresh one. Worn-out batteries are of no further use.

Unnecessary use. 31-856. The fact is emphasized that the battery will discharge whenever the filament is lighted and the plate circuit is closed. For this reason, among others, the filament should not be lighted except when necessary for receiving. Satisfactory service can not be obtained from the SE 3535A battery after the voltage has dropped below 17 volts on discharge.

Storage. 31-857. Batteries in stock should be stored in a cool dry place with the side having the sealing compound up. Care should be taken also that no battery is accidentally short-circuited by the leads touching, and thereby run down.

PART 3.—THE EDISON "B" BATTERY.

Edison battery. "B" 31-858. (1) A special storage battery has been developed by the Edison Co. for use in the plate circuit. The cells are made very small and 48 are connected in series to give a normal discharge voltage of 60 volts. The charging rate is one-half ampere for 7 hours when the battery is fully discharged. The characteristics and methods of care and upkeep for this battery are not given here as they are similar to those described elsewhere in this manual in the general discussion of the Edison battery.

(2) The Edison "B" battery has the advantage over the dry battery in that it can be kept in good condition by proper care and charging when needed. On the other hand the type SE 3535A dry cell occupies but little space but has a disadvantage of a comparatively short life and after exhaustion must be replaced by a new battery.

PART 4.—THE EDISON "A" BATTERY.

Edison battery. "A" 31-859. It was stated above that a considerable current at a low voltage was required for lighting the filaments. The 6-volt storage battery (either the Edison or the lead-acid type) is used. The Edison battery is rated at 75 ampere hours, while the lead-acid type of battery generally used has a capacity of either 80 or 100 ampere hours. A fairly high capacity battery is preferable, especially where multi-stage amplifiers are in use, in order to maintain the required voltage for a reasonable length of time and to reduce the frequency of charging.

Charging units. 31-860. Special battery charging panels have been supplied to ships using 120 volts direct current so that the batteries may be charged from the ship's circuit. At a number of isolated places, chiefly radio compass stations, it is necessary to use small gasoline engine driven generators for this purpose, and at other installations where alternating current power must be utilized various forms of rectifying devices have been provided. The charging and maintenance requirements of these batteries differ in no essential way from those for the usual power battery and will therefore not be taken up here.

PART 5.--POWER STORAGE BATTERIES.

31-861. Storage batteries are very generally used to provide an emergency power supply on shipboard for radio sets where an emergency power supply is essential. The lead-acid type of battery has been used exclusively for this purpose. Such batteries are supplied in four sizes, namely, 40 ampere hours, 80 ampere hours, 140 ampere hours, and 240 ampere hours, the voltage being 120 volts in each case. The size of battery is selected in accordance with the size of the set to be operated, which range from one-fourth to 5 kilowatts. Each 120-volt battery consists of a group of conveniently sized trays, each tray usually consisting of three cells. The trays are grouped together in a convenient and suitable location especially adapted to the purpose.

Description.

31-862. Storage batteries are used to operate the dynamotors of the type CW 936 telephone sets, the dynamotor generating the high voltage necessary for the plate circuit. Storage batteries are also used to a considerable extent on aircraft to operate the smaller transmitters as well as the receiving equipment.

Purpose.

31-863. The following is a list of the storage batteries now in general use in the Naval Radio Service:

Types.

EDISON.

Type No.	Voltage.	Ampere hours.	Use.
CU 119.....	6	75	Filament lighting.
CU 121.....	4.8	12.5	Do.
CU 887.....	60	2.5	Plate supply.
CU 1767.....	60	2.5	Do.

LEAD-ACID.

RAD-1.....	140-110	13	1/2-kilowatt emergency spark transmitters.
RAD-1.....	120	80	1/2-kilowatt emergency spark transmitters.
RAD-1.....	120	140	1-kilowatt emergency spark transmitters.
RAD-2.....	120	210	2 and 5 kilowatt emergency spark transmitters.
RAD-T.....	32	40	CW 936 telephone.
6 TX-19.....	12	60	Aircraft radio.
SOR-30.....	12	40	Do.

31-864. The operation and the faults and remedies of storage batteries, both the Edison and lead-acid types, are given in detail in the chapter on storage batteries.

Detailed instructions.

SECTION VIII.—FIELD SETS.

PART 1.—GENERAL.

31-875. Field sets are used in the Naval Communication Service to establish radio communication between a landing party and the ship, between landing parties for point to point radio communication on shore, and also for emergency transmitters on board ship.

Purpose.

31-876. The equipment includes all the apparatus necessary to establish a transmitting and receiving station independently of the

Equipment.

locality selected. The 500 cycle quenched-spark transmitter is used at present for this purpose and the power for driving the 500-cycle alternator is supplied by (a) hand generator, (b) gasoline engine, and (c) direct current motor.

(2) A complete mast, antenna, and counterpoise, together with transmitting and receiving equipment and spare parts, all arranged in portable form, constitute the field set.

Theory.

31-877. The theory of the transmitter is the same as that given for the Navy Standard 500-cycle quenched-spark transmitter. The receiving apparatus is similar to that already described under "Receiving equipment." The antenna and ground system is different from the usual type only in the fact that it is of the umbrella type, portable, and employs a counterpoise. A description of the $\frac{1}{4}$ -kilowatt portable radio set, type CN 233, follows:

PART 2.—DESCRIPTION.

Apparatus.

31-878. (1) The $\frac{1}{4}$ -kilowatt portable radio set consists of four parts:

- (a) Portable mast.
- (b) Parts for mast, portable antenna and counterpoise.
- (c) Transmitter and receiver.
- (d) Power system complete.

(2) A hand cart for the transportation of the set is also supplied.

Portable mast.

31-879. (1) The portable mast consists of 6 poles. Two pike poles are supplied for use in erecting the mast and two canvas bags to cover the ends of the poles when packed.

(2) The mast is secured at its foot by an anchor spike equipped with bolt and nut and pipe to hold the lower end of the pole.

(3) Four guy lines on reels are supplied for holding the mast in a vertical position. One of these is a heavy line for use in lifting the mast and is used as the forward guy. The latter guy line is permanently fastened to the guy distribution plate. Four long spikes for the pole guys and six small spikes for the antenna guys are a part of the equipment.

Antenna.

31-880. (1) The antenna is of the 6-wire umbrella type. Each antenna wire is wound on a hand reel and is equipped with cord, insulators, and a device for attaching the wire to the mast.

Rattail.

(2) The rattail is wound on a reel and equipped with cord, insulator, and a snap hook for connecting the lead to the insulated distribution plate of the antenna.

The counterpoise.

31-881. The counterpoise equipment consists of two 4-wire insulated counterpoises with attaching plugs.

The transmitter and receiver.

31-882. The transmitter and receiver are assembled in the same chest. An 8-conductor cord with multiple plug at each end for connecting the power unit to the transmitter, a single conductor cord with plug on one end and with suspender clip on the other for connecting the antenna to the plug marked "ant" on top of antenna loading coil IV, a single conductor cord for connecting the counterpoise plug to a bulkhead or other direct ground only when the set is used on shipboard are supplied. In addition, a pair of telephones, spark-gap tester and an oscillation trans-

former tool for removing or inserting the plugs on the end of the wave-changer connectors are a part of the equipment.

31-883. (1) The power system consists of an alternator with exciter on a sliding base with a coupling on each end of the alternator armature shaft, an internal-combustion engine with built-in magneto, oil and gasoline tanks, crank and governor, a direct current motor for sliding base with coupling on one end of armature shaft and various attachments, boxes, and stands.

The power system.

(2) The engine of the power supply system is a single cylinder 4-cycle, air-cooled, three-fourths horsepower, 2,500 revolutions per minute machine. A governor is provided which keeps the speed within the specified limits. A built-in magneto is used for ignition. An oil tank with gauge is provided and a gasoline tank with shut-off petcock are provided. A "compression release" is provided for starting and stopping the engine.

Engine.

(3) The alternator is practically a hand generator. No means are supplied for disengaging the gears when the engine is used. The alternator voltage is controlled by a rheostat in the exciter field, the exciter voltage being 70 volts.

Alternator.

(4) The direct current motor may be included in the landing-force equipment and coupled to the alternator when the latter is being run by the gas engine. The motor then operates as a generator for lights. The gas engine will run the alternator under sending conditions without trouble but, if more than one light is supplied from the direct current motor acting as a generator with full load on the radio set at the same time, the engine will overheat. A switch is provided for use when the direct current unit is being used as a motor or as a generator. A portable light with cord is also supplied which may be plugged into a receptacle on the power unit frame.

Motor.

(5) The following power combinations may be used by proper combinations of engine, alternator, and D. C. unit:

Power combinations.

- (a) Alternator driven by engine.
- (b) Alternator driven by motor.
- (c) Alternator driven by hand power.
- (d) Alternator and D. C. unit driven by engine.

PART 3.—OPERATION.

31-884. The site selected for the erection of a station should be fairly level and free from undergrowth. It is preferable to set up the station in a clearing as far as possible from large trees. The site should also be selected so that the line connecting the field station and the station with which it is to work is as free as possible from large obstructions to the passage of the transmitted wave. For example, large hills and heavily wooded areas in the line of communication should be avoided. The use of the counterpoise permits a considerable latitude in the selection of the site because the counterpoise makes the set independent of ground conditions. Nevertheless very rocky soil should be avoided when possible.

Selection of site.

31-885. The mast is of the guyed type and is quite flexible, but will break or jam at the joints if the mast is not properly erected. The mast should be erected in the following manner:

Erection of mast.

(1) Drive main stake (the one with the yoke and bolt) using the wooden mallet.

(2) Connect sections 1 to 6 inclusive of the mast, No. 1 being the bottom section. The mast is laid out on the ground in line with the steel tubing in the yoke on the main stake. The brass guy distribution plate is placed between sections 4 and 5 and the three separate guys (back guy and two side guys) are snapped in place on the plate. The fourth guy (forward) is already attached.

(3) Insert in the lower end of the completed mast the piece of steel tubing on the yoke. The mast is then connected by the bolt to the U-shaped piece driven in the ground and is now hinged to the main stake.

(4) Drive one large iron pin on each side of the mast and about 20 feet from the main stake in a line at right angles to the mast. Attach the two side guy lines to these pins adjusting the tension by the tent slides provided. These guys prevent sliding and swaying of the lower section during erection of the mast.

(5) Drive another large iron pin in the ground near the point where the third and fourth sections of the mast are joined (when the mast is lying on the ground). Attach to it the back guy line estimating the tension adjustment of the tent slide by that previously found for the side guys. Drive remaining large iron pin about 20 feet in front of the main post and in line with the mast. Unreel the front guy (erecting line), adjust heavy guy line permanently attached to the guy distribution plate and lay it on the ground alongside the mast toward the last large iron pin driven.

(6) Insert insulator in the top of the mast and attach the six antenna wires and the leading down wire. Two of the antenna wires are now unreeled to their full length including cord, one on each side of the mast and fastened to two small stakes. These stakes are in line with the first two driven for the side guys and the two antenna wires are laid out in the same direction as the side guys thus forming additional side guys for the top section of the mast to prevent side sway. Unreel the leading down wire and lay it alongside the mast in such position as not to be in the way when the mast is being erected. Unreel partly the four remaining antenna wires and lay the reels on the ground, two on each side of the base of the mast.

(7) Connect together the two pole sections marked "pike" and insert in one end the yoke piece having the wooden stem.

(8) One man is now detailed to raise the mast about 3 feet at the point where the guy lines are attached by lifting the mast by hand. A second man is now detailed to place the yoke of the pike pole under the mast immediately under the lower side of the guy distribution plate. The first man now leaves the mast in the hands of the pike man and takes hold of the heavy forward guy at the far end (near the larger iron pin). The two men now lift the mast, working together until it is perpendicular. It is then held in this position while the back stay is adjusted to have the proper tension and the forward erecting line is attached to the large iron pin and adjusted for tension.

(9) Unreel the four remaining antenna wires and make them fast to the four small iron pins provided. The antenna wires are to be equally spaced at an angle of 60 degrees between the wires. The tension on the antenna wires is then adjusted, one at a time, with such readjustments as are necessary to make the mast straight.

(10) Unreel the counterpoise wires, taking care not to kink the wire. The wire should be laid out from the base of the mast, making an angle of approximately 45 degrees with each other.

The antenna wires should be unreeled by grasping the reel by the handle and walking away from the mast. If three men are available for erecting the mast the third man can aid in the erection by pulling on the antenna wire in line with the forward erecting guy.

31-886. The instructions for taking down the mast are as follows: Taking down
the mast.

(1) Reverse the order of procedure given for erecting the mast except that the man with the pike will "catch" the mast when it is part way down on the upper side of the guy distribution plate instead of on the lower, so that the pike will not slip on the mast. After the mast is down it is well to reel up all wires and guys, as the reeling can be done more easily when these are still attached to the mast. In reeling up, hold the reel by the handle and revolve the reel by using the short piece of brass tubing provided as a handle. Do not attempt to wind up the wire by hand, but use the reel, turning it over and over in a direction away from the body. Keep a slight tension on the wire.

(2) Great care should always be exercised in handling the counterpoise and, when reeling in, do not allow the counterpoise wire to kink. The wire should be wound on the hand and elbow with a long, free motion. Do not drag the wire on the ground—walk up on it as it is being reeled in.

31-887. (1) This apparatus should be located close to the foot of the mast. It may be raised above the ground for easy operation by placing it on suitable supports. The box is then opened. The front portion of the chest may be slid out. This leaves the entire front part of the case open to the operator, making it easier to send and receive. The wing nut permanently attached to the removable front cover may be used to attach the latter to the cover of the transmitting case, so that the top part of this case may be held in an upright position during use. Means are provided for holding the top open securely (when opened to the 90° position), so that it will not accidentally close during operation. Transmitter
and receiver
chest.

(2) The antenna lead-in and counterpoise connections can then be made to the transmitter and receiver case, as well as the 8-conductor cord for connecting the power unit to the transmitter. Connections.

(3) The transmitter and receiver are similar to the usual Navy apparatus. A complete diagram of the connections is secured on the left-hand side of the box. In addition a complete set of operating instructions is furnished with each set. The transmitter has a wave-length range of from approximately 200 to 1,200 Transmitter
and receiver.

meters with the standard portable antenna and is provided with an inductive coupler and wave changer. The primary circuit is adjusted to the following 5 wave lengths: 450, 600, 750, 950, and 1,200 meters. Any other wave length within the range can be used. It is usual to use a fixed coupling between the primary and secondary coils of about 3 inches, as this allows room for any necessary variation in the coupling. The procedure for tuning has been covered in section II(A), part 3.

Power unit. 31-888. (1) The power unit for field work is usually driven by the gasoline engine. The following is the procedure for operating the engine:

Starting engine. (a) Fill the gasoline and oil tanks. Open petcock in gasoline-supply line. Depress compression release and shut off the main air inlet of the carbureter by the button provided, so that a richer mixture may be obtained in starting.

(b) Crank engine at a high speed and release the compression-release rod as soon as the engine starts to run by its own power; also open the main air inlet and remove crank.

Stopping engine. (2) To stop the engine:
(a) Press the compression-release rod until the engine comes to rest.

(b) Shut off the gasoline supply to the engine by closing the petcock in the gasoline-supply line.

Hand cranking. 31-889. When the alternator is driven by hand the compression-release rod on the gasoline engine should be kept depressed, as otherwise the compression will make cranking very laborious.

PART 4.—FAULTS AND REMEDIES.

General. 31-890. The faults that may occur in either the transmitter or receiver have been fully covered elsewhere in this manual. The power unit may develop the following faults:

Failure of the generator to generate. 31-891. (1) This is usually due to exciter trouble. The brushes are either not making good contact with the commutator or the commutator is dirty. A small piece of sand paper is supplied with each set for the purpose of cleaning the commutator. It should be held lightly against the commutator while the armature is revolving. This will generally remedy the fault. In case this does not remedy the difficulty the brushes should be carefully cleaned. If now the alternator does not generate the exciter and alternator field circuits should be inspected for open circuits. The exciter can be tested with a 110-volt lamp. If the exciter is found to be in good condition the alternator armature may be defective. Spare parts supplied with the set are ample to repair any ordinary breakdown.

Failure of the engine to run. 31-892. (1) Failure of the gasoline engine to operate may be due to—

- (a) Lack of gasoline.
- (b) Poor adjustment of carbureter (rare).
- (c) Faulty ignition, due either to fouled spark plug (usual) or a fault in the magneto (rare).

(2) The speed obtained by cranking is always sufficient to start the motor unless one of the faults just mentioned exists.

(3) If the gasoline engine runs but not at a sufficient speed to give 500 cycles from the alternator it may be due to—

(a) Poor adjustment of carbureter. If the choke is closed the engine will receive a rich mixture and will not develop full power. Open the choke and if the engine does not run at a high enough speed adjust the carbureter.

(b) Governor may be sticking.

(c) If the direct-current motor is coupled and is carrying a load at the same time that the alternator is being used, the engine will be overloaded and will not develop sufficient speed.

(d) Do not run the engine if no oil appears in the oil gauge beneath the magneto. Lack of oil.

31-893. Do not use more than one light on the direct-current generator with full radio load being drawn from the alternator by the radio set because the engine will overheat. One light only can be used under these conditions. Lights.

31-894. When the set is being used on board ship and is driven by the gasoline engine the exhaust gases should be removed from the compartment rapidly. Exhaust gases.

31-895. The counterpoise has a heavy insulation to prevent it from grounding. In case a kink or break in the insulation occurs the break should be taped carefully with rubber and empire cloth tape. Care of counterpoise.

31-896. The $\frac{1}{4}$ -KW. portable field set is ruggedly built and will stand a moderate amount of handling such as is encountered in ordinary service. Broken connections, loosened supports, and other faults will develop if the set is handled roughly; therefore, care in the transportation and storage of the set should be exercised. After use in the open or after exposure to sea air, rain, etc., the set should be carefully cleaned and dried and put into condition for use with the next landing party. General inspection and care.

SECTION IX.—RADIO COMPASS EQUIPMENT.

PART 1.—GENERAL.

31-900. The purpose of the radio compass is to permit the determination of the absolute direction and geographical position of a radio transmitter. The principle involved in both ship and shore radio compass installations of the U. S. Navy is the same while the operation and equipment of the two types of installation differ slightly on account of the particular requirements. Purpose.

31-901. The radio compass station on shore is located at advantageous points along hazardous coast lines or at important harbor entrances for the purpose of providing bearings from known positions to the vessels navigating in the vicinity. Where two or more stations are located adjacent to a particular harbor entrance, two or more simultaneous bearings of a vessel may be obtained, thus furnishing a fix which will enable the vessel to plot its position. This is accomplished by building stations in groups of two or more and connecting them by telegraph or radio and by using one of the stations in the group as a central station, where the observed bearings are plotted and then forwarded to the vessel. Shore stations.

Wave length. 31-902. The wave length allocated to shore radio compass traffic is 800 meters. All radio compass work with shore is conducted on this wave length alone.

Ship stations. 31-903. (1) The radio compass has been installed on certain types of Naval vessels for the purpose of enabling commanding officers to determine the true bearing from the vessel to another vessel or to a radio station on shore. Such installations determine along what line a given transmitter lies, but do not indicate the absolute direction. This is due to the fact that the radio compass receives equally well from two diametrically opposite points and, for this reason, there exists an ambiguity in direction of 180° . In order to determine direction it is necessary that the observing vessel make two observations with a run between. When the course and bearings are plotted, the position of the transmitter is indicated by the intersection of the two lines of bearing.

(2) The radio compass aboard ship determines the direction of the transmitter relative to the heading of the ship; therefore, to obtain the true bearing, the heading of the ship must be observed simultaneously with the radio compass bearing and applied to the latter.

(3) The 180° ambiguity also exists in the shore station installations, but, due to the fact that a bearing from a vessel would not come from inland (there are a few exceptions to this in the case of river navigation when the vessel is near the mouth of the river), this discrepancy would not occur. The possibility of the direction of the line of bearing being in error by approximately 180° is entirely eliminated in the case of group stations, because the intersections of the lines of bearing would indicate in which direction the transmitter is located.

Degree of accuracy. 31-904. The possibility of obtaining satisfactory results with the radio compass on shipboard has been established by the experience of numerous navigators. It is more difficult to obtain an accuracy comparable to that obtained at shore stations on account of the metallic structures in close proximity to the coil system, the dissymmetry of the vessels as well as of the lack of experience of the radio personnel. Despite these adverse conditions it is entirely possible to obtain radio bearings having the same degree of accuracy as that obtained by the usual means of navigation.

Careful supervision necessary. 31-905. In order that the desired conditions just mentioned may be the rule rather than the exception, it will be necessary for officers in charge of the installation, calibration, and operation of the radio compass equipment on ship and shore to make certain that the installations are made in conformity with the standard practice, that the calibrations are conducted with extreme care and accuracy, and that the equipment is operated intelligently at regular periods, in order that the personnel may become expert and reliable.

PART 2.—THEORY.

Antenna is non-directional. 31-906. The antenna of moderate horizontal dimensions is non-directional. This can be proved by moving the radio transmitter so as to make a complete circle about the receiving antenna and plotting the emf induced in the antenna against the angular posi-

tion of the transmitter. The resulting polar diagram will be a circle showing that the emf induced in the antenna is the same for reception from all directions. Therefore, the signal will not vary in intensity and the direction of the transmitter can not be determined.

31-907. (1) If a loop consisting of several turns of wire wound on a fairly large form is arranged for receiving, as shown in figure 31-45, so that it can be rotated on a vertical axis, the loop will make a varying angle with the direction of the source of electromagnetic waves produced by a fixed radio transmitter. If the emf induced in the loop is plotted in a polar diagram against

Directional characteristic of loop.

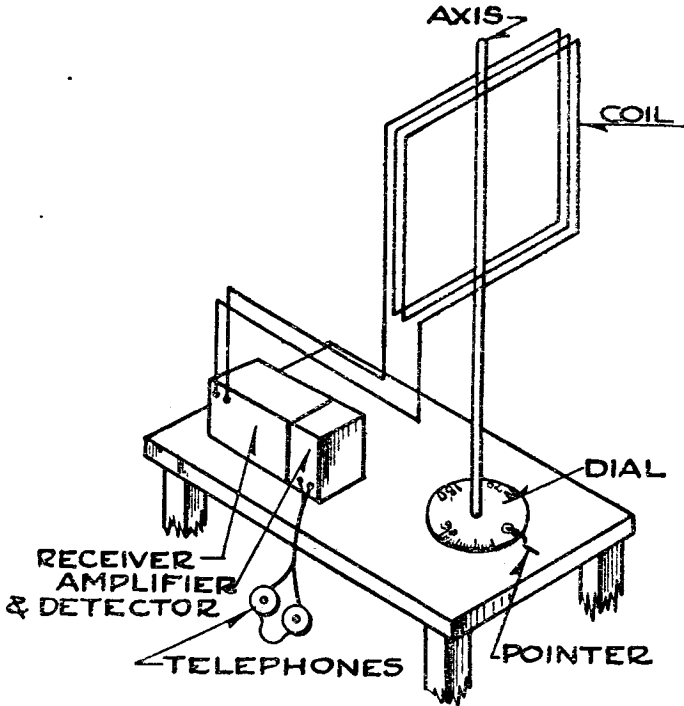

Fig. 31-45.—Arrangement of radio-compass coil and apparatus.

the angular position of the loop, the resulting curve will be similar to that shown in figure 31-46. This is called the figure 8, or bilateral characteristic curve of the loop. Figure 31-46 shows a top view of the coil and the dial which is securely attached to the vertical shaft of the loop. The pointer in this case is set on the north-south line. It will be seen from the position of the figure 8 curve that a maximum signal will be received when the transmitting station is either east or west of the loop—that is, when the plane of the loop coincides with the east-west line. Now, if the transmitting station were on the north-south line it would not be heard. Thus it is clear that two maximum and minimum points are passed through as the loop is rotated through 360°.

Emf's in loop. (2) The electromagnetic wave from the transmitter passing through the loop induces in the vertical sides of the loop equal emfs which are slightly out of phase. The resultant emf, which is extremely small, sets up a flow of current in the loop. This current either lags behind or leads the electrical component of the wave by 90°.

Maximum and minimum signal positions.

(3) The maximum signal will be received when the plane of the loop coincides with the line of bearing of the transmitting station. As the loop is rotated from this position the signal will decrease in strength, finally becoming zero when the plane of the loop is at right angles to the direction of the source. The maximum signal method of determining direction is not used in radio compass work because the bearing cannot be determined very accurately. This is made clear by the shape of the characteristic curve. It will be seen, however, that the point

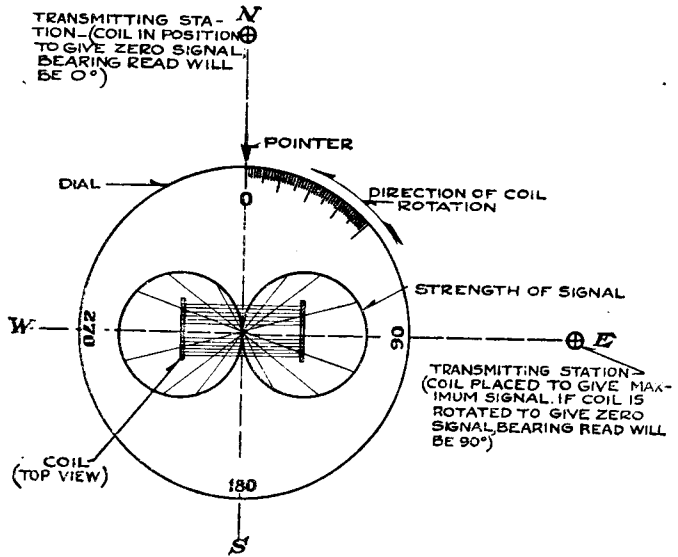

FIG. 31-46.—Top view of radio-compass coil and dial.

of zero signal is very sharply defined and for this reason the null method is used for determining direction.

Practical application.

31-908. The previous discussion relates to the theory of an ideal compass system acted upon by an undistorted electromagnetic wave. This condition is not realized in actual practice. The departures from the ideal compass are due to the defects or nonsymmetry of the apparatus itself and to the distortion of the electromagnetic wave before it reaches the coil. The defects and nonsymmetry of the apparatus can be compensated for to a large extent. The distortion of the wave, due to refraction, diffraction and reflection can be partly eliminated by a proper choice of the location of the station.

Maximum method used on air craft.

31-909. It was stated above that all bearings are obtained by observing the position of the coil in relation to true north when

the minimum signal is being reached. This holds for all ship and shore radio compass stations but not for aircraft installations where the maximum method is frequently used; therefore, in order to make an accurate observation, it is essential that the minimum be clearly defined and cover as small an arc (zone) as possible, or better still, that there be a *point* on the arc at which no signal is heard (null point) such that the slightest change from this will result in the signal being heard.

31-910. The above applies to a perfect compass. In practice the null point is seldom found, but in its place there is either a zone of minimum signal or a zone of silence caused by the non-symmetry of the apparatus, reradiation, and intensity of signal, etc. The length of the zone of silence is decreased as the signal strength is increased. The breadth of this zone determines the possible accuracy of the equipment. Therefore, by the proper design of the circuit and with sufficient amplification this zone of silence can be reduced to approach the null point as a limit.

31-911. The most common cause for the destruction of the null point in the practical radio compass is the antenna effect. This effect is due to the electrical dissymmetry of the radio compass

Zone of silence.

Antenna effect.

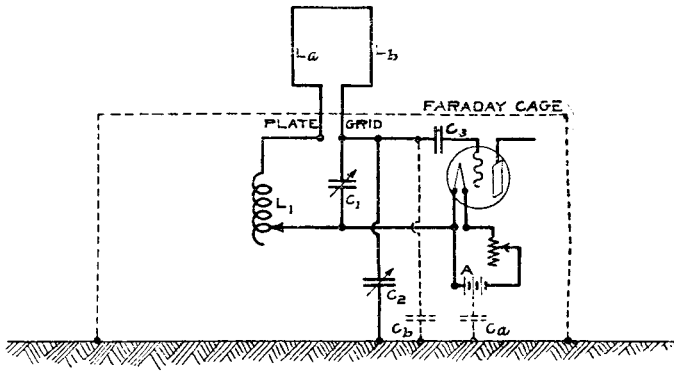

FIG. 31-47.—Diagram showing electrical dissymmetry of the practical radio compass.

circuit. Consider figure 31-47 where the radio compass coil is installed above a symmetrical Faraday cage containing the receiving apparatus and the operator. The terminal from the vertical side of the coil marked L_a is connected to the filament of the vacuum tube of the receiving apparatus (detector or amplifier) while the side marked L_b is connected to the grid. An electrical dissymmetry exists on account of the unequal capacities to ground of the filament C_a and of the grid C_b caused mainly by the proximity of the filament battery to ground. This unbalancing of the circuit permits the coil to function additionally as an open oscillator. Therefore, when the plane of the coil is at right angles to the direction of the propagation of the electromagnetic wave and the current induced in the coil is zero there is also a current induced in the circuit due to the coil system acting as an antenna. For this reason the zone of silence is obscured by a residual signal having a practically constant intensity. This disturbing effect

is eliminated by restoring the symmetry of the circuit by the addition of sufficient capacity from the grid to ground to balance that of the filament to ground. This capacity C_2 is called the compensating condenser and consists of a small continuously variable air-dielectric condenser which is thoroughly shielded and has a very small capacity at zero setting.

Compensating
condenser adjust-
ments.

31-912. The presence of the antenna effect and the use of an artificial capacity balance makes it necessary to use extreme care in tuning the circuit because any adjustment of the compensating condenser C_2 will disturb the wave length of the circuit and require a readjustment of condenser C_1 . This change in wave length, or detuning from resonance with the incoming signal, causes a shift in the position of the minimum, thereby giving rise to an error in the determination of direction.

Effect of low
resistance cir-
cuits.

31-913. More freedom from interference and the possibility of decreasing the length of the zone of silence is obtained with the use of a coil system having a very low radio frequency resistance. A low resistance circuit is especially important when the nonoscillating detector followed by audio-frequency amplification or the radio-audio-frequency amplifier is used. On the other hand, if the autodyne or heterodyne method of reception is employed the resistance of the loop does not count.

PART 3.—DESCRIPTION.

Types of equip-
ment.

31-914. There are four standard types of radio compass equipment in use at the present time in the naval service on ship and shore. These may, for convenience of description, be classified as groups A, B, C and D. Groups A and B are shore station installations, comprising the standard type SE 515A coil system, commonly known as the 6-foot coil, a suitable receiver designed both for oscillating and nonoscillating conditions, audio-frequency amplifier, compensating condenser and the necessary auxiliary apparatus. Groups C and D are the present standard for installation on destroyers and similar vessels. Group C consists of the type SE 995 radio compass coil system, SE 1012 receiver and the SE 1000 amplifier. Group D, which is the standard type SE 1512 radio compass, comprising the type SE 1512 coil and shaft system and the type SE 1440 receiver, presents several innovations, the principal one being the control of inductance in the loop. No standard compensating condensers have been developed as yet for groups C and D.

Group C.

31-915. The type SE 995 radio compass, which was the first to be put into general use in the naval service, was designed for determining the direction of a transmitting station employing either damped or undamped oscillations, within a range of wave lengths whose limits were 100 and 1,000 meters. This type was intended primarily for installation on destroyers.

Groups A and
B.

31-916. Subsequently, the type SE 515, superseded by the type SE 515A, was developed. This was likewise designed for both damped and undamped wave reception, with an operating range of from 450 to 1,500 meters. The purpose of this type was for use at shore stations, whose function is to furnish bearings to all

types of vessels. These shore stations are located in groups with ample base lines to furnish accurate cross bearings, enabling a navigator to determine the position of his vessel.

31-917. (1) The type SE 1512 is the latest type of radio compass for installation on destroyers. In efficiency, it greatly exceeds the type SE 995, due to the increased dimensions of the coil system, the improved receiver and amplifier, type SE 1440, and the novel feature of a switching device for altering the inductance in the coil system, which permits a high ratio of inductance in the loop to tuning capacity throughout the operating range of wave lengths.

Group D.

(2) There are four steps of loop inductance controlled by the switching knob on the end of the shaft, corresponding to the four inductance steps on the receiver. The purpose is to enable the operator after tuning the incoming signal, using the auxiliary antenna in destroyer installations, as in an ordinary radio receiver, to throw over to "compass," adjust the loop inductance switch to correspond with the inductance step used on the receiver, which tunes the loop to the particular wave.

(3) The wave length range of this type is from 200 to 1,150 meters, and can be used both for damped and undamped waves.

31-918. The component parts of these groups with their type numbers are listed below. Equipment of the groups.

(1) *Shore stations* (Groups A and B) :

Group A—

Six-foot coil system, with direct reading dial, type SE 515A.

Receiver, range with above coil, 450-900 meters, type SE-1440.

Compensating condenser, range 15 to 300 $\mu\mu\text{f}$ (adjustable).

Amplifier, 3 stage audio-frequency contained in receiver.

Auxiliary apparatus, comprising communication lines, power plants, etc.

Group B—

Six-foot coil system, with direct reading dial, type SE 515A.

Receiver, range with above coil, 450-1,600 meters, type SE 1012.

Amplifier, 2 stage audio-frequency, types SE 1000, 1000A, 1000B, 1000C, or 1600A.

Compensating condenser and auxiliary apparatus as in group A.

(2) *Ship Stations* (Groups C and D) :

Group C—

Coil system and shaft type SE 995.

Receiver range with above coil system 200-1200 meters type SE 1012.

Amplifier, 2 stage audio-frequency, type SE 1000, 1000A, 1000B, or 1000C.

Auxiliary apparatus comprising charging panel, gyro-compass repeater and communication to bridge.

Group D—

Coil system and shaft with switch for varying the inductance in the coil, type SE 1512.

Receiver, range with above coil system, 200-1150 meters, type SE 1440.

Amplifier, 3 stage audio-frequency contained in receiver.

Auxiliary apparatus comprising a charging panel, gyro-compass repeater, and communication tubes to the bridge.

Communication lines (shore stations).

31-920. (1) Intercommunication between the various radio compass stations of a group is maintained by means of land lines, the central radio compass station only being equipped with a radio transmitter. For this purpose it is the custom to simplex the United States Coast Guard telephone lines, thus establishing a means of communication which is independent of the telephone circuits, and in turn does not interfere with the telephone service. As the current flowing through a line which may be many miles long is quite feeble, it is necessary to use a relay to which may be connected either a sounder or a radio buzzer.

(2) The central radio compass station of the group is provided with a radio transmitter of sufficient power to communicate with vessels requesting bearings. This necessitates an antenna, the proper location of which is important. In connection with this there is required (a) a clapper switch for starting the motor generator, remotely controlled from the radio compass house; (b) a signaling relay, also controlled from the compass house; and (c) an anchor gap which effectively disconnects the antenna system from the transmitter when not in use. It is imperative that this anchor gap be properly adjusted since the antenna system, if connected to earth through the transmitter which is tuned, would cause serious deviations in the radio compass.

Communication tube (ship stations).

31-921. Intercommunication between the radio compass station (after radio room on destroyers), the main radio station and the bridge, is effected by means of voice tubes.

Power plants (shore stations).

31-922. Radio compass stations having radio transmitters are supplied with a 3-kilowatt gas engine driven generating plant and a 120-volt, 210 amphr. storage battery; also one $\frac{3}{4}$ -kilowatt gas engine charging unit for charging the receiver batteries. Those without radio transmitters are supplied with two $\frac{3}{4}$ -kilowatt, 30-volt, gas engine driven generating plants, with one set of spare parts. Stations located within reach of a power line are equipped with (1) motor generators, (2) mercury rectifiers, or (3) magnetic rectifiers, for charging the batteries. In ship installations the ship's power mains are used for this purpose.

Charging panels.

31-923. These are supplied in both ship and shore installations to control the power for battery charging.

Batteries (power).

31-924. For the isolated radio compass station with a radio transmitter, a 120-volt, 210 amphr. battery is supplied. There are two types standard—the Exide and the U. S. Lead.

Batteries (receiver).

31-925. The 6-volt, 80 amphr. (Edison) or lead plate, is the standard for the A battery. There are two standard types of B

batteries—(1) The type SE-3535A; (2) The Edison B battery, types CU-887 and CU-1707.

31-926. The type CW-834 is the standard head set.

Telephones.

PART 4.—INSTALLATION OF RADIO COMPASS EQUIPMENT ON U. S. NAVAL VESSELS.

31-927. (1) The location which has been established as standard on destroyers is in the forward-port compartment of the after deck house. Destroyer installation.

(2) Communication with the bridge is obtained by means of a voice tube and call bell. Communication with bridge.

(3) In the same compartment with the radio compass equipment is installed a small auxiliary quenched-spark transmitter of about one-quarter or one-half kilowatt capacity, with an emergency storage battery and suitable charging panel. In some cases the storage battery is installed in a locker just across the passage-way from the compass compartment, otherwise in the same room with the transmitter. Additional equipment.

(4) The various metallic structures surrounding the loop will produce deviations of varying magnitude unless certain precautions are taken. The stays to the after mast should be broken near their upper ends with strain insulators and securely grounded to the hull of the vessel at their lower ends by means of flexible copper jumpers. The safety railing placed around the edge of after deck houses on some destroyers must not extend around the compass coil house. This railing should end at points several feet from the coil house, and it is advisable to insert nonmetallic rope horizontal members in place of metallic rail adjacent to the compass coil house. If the space surrounding the loop is occupied by metallic lockers or structures of a similar nature, satisfactory performance can not be expected. Closed metallic loops and metal structural details in close proximity to the compass coil cause excessive deviation. Treatment of surrounding structures.

(5) The lead from the after half of the auxiliary antenna is brought into the compass compartment for use with the auxiliary transmitter. This lead should be run through a grounded metallic antenna trunk, the top of which must be at least 18 inches above the top of the coil house to the entering insulator. Antenna lead.

(6) All radio compass bearings are taken as angles turned from the center line of the ship and the bow as zero degrees. In order that this may be accomplished the dial must have the correct relative position with respect to the loop. The pointer should be placed on the underside of the bearing support so that the dial reading may be easily observed by the operator. The loop should then be turned so that the plane of the turns is at right angles to the center line of the vessel and the dial made to register 0° or 180° and clamped tight to the shaft. In order to place the dial on the shaft it will be necessary to remove the handwheel and switch control knob. These two parts should be replaced in their former position after the dial has been placed. Setting of dial.

(7) The tuning of the auxiliary transmitter is properly a part of this installation work and may be advantageously accomplished at this time. Tuning of transmitter.

- Amplification.** (8) With a wavemeter in operation on the upper deck distant about 6 feet from the loop the various stages of amplification should be tested. The usual increase for each step should be checked as well as the tendency to howl. Howling may sometimes be traced to an open loop circuit and in this case the contact fingers should be inspected.
- Oscillation.** (9) Both of the receivers used for compass duty should give strong oscillations over the working range of wave lengths. Reversed batteries, open loop circuits, or metallic closed loops in the vicinity of the loop will prevent oscillations. An extremely sensitive test for the quality of contact at the loop collector rings consists of rotating the loop while the circuit is oscillating. If there are neither grinding nor clicking noises an excellent installation is indicated.
- Quality of minima.** (10) It is desirable that some investigation be made as to the quality of minima obtainable. In extreme cases the capacity of the compensator may not be sufficient. This should be determined and corrected before the vessel leaves for calibration.
- Calibration for wave length.** (11) The dial of the loop condenser should be marked in red at the tuning points for the standard waves within the range of the apparatus. This dial may then be marked when the receiver is being used with the antenna.
- Installation on all types of vessels. Space requirements.** 31-928. (1) The compartment which has been assigned for compass equipment on destroyers represents about the minimum space in which such an installation can be made. A compartment at least 6 feet square is desirable if the operator is expected to stand duty for an appreciable length of time. The practice of installing the compass in the same compartment with the service radio installation, while being more compact, is not particularly desirable from the consideration of compass operation. When it is installed in the radio compartment it is difficult so to carry the antenna lead that it will not seriously affect the compass.
- Symmetry with respect to the hull.** (2) The metallic hull of a vessel has an important influence on the direction of travel of the incoming radio waves. Instead of continuing in a straight line the waves are bent and tend to follow the length of the vessel. It is this condition which produces the major portion of the deviations noted. Therefore, it is desirable to have the installation so located with respect to the hull as to distribute the deviations symmetrically.
- Height above decks.** (3) The advantage gained by any particular height is small, provided the height is 6 feet or over. This dimension refers to the loop itself and not to the operating room, and is subject to the further condition that there be no metallic superstructure within 50 feet of it. If such a spacing is impossible to obtain at any point on the vessel it is advantageous to mount the loop above all superstructure except the funnels and stacks.
- Mast stays.** (4) Should the location selected place the compass loop in the vicinity of a mast the mast stays must be broken by strain insulators at a point near their upper end. Electrical jumpers should be attached to the lower end of stays and the metal structure of the vessel in order that the electrical conditions of these stays will remain constant.

(5) Antenna leads will cause wide deviations which, furthermore, will vary with different conditions of the antenna circuit. It is, therefore, extremely desirable to locate the radio compass at some distance from all antenna leads. If such a location is impossible the influence of the antenna lead may be reduced by carrying it in a grounded trunk to a point above the top of the compass loop. Precautions will then be necessary to keep the antenna in the condition obtaining during calibration at such times that the compass is being used.

Antenna leads.

(6) If the compartment provided for the instruments is not of metal it will be necessary to line it completely with a fine mesh copper screening. This lining should include the doors with suitable grounding strips to complete the shield when the door is closed, and screening over all of the ports.

Electromagnetic shielding.

(7) The loop system should be mounted on the deck over the operating compartment so that the control shaft will extend into it.

Location of loop system.

(8) The equipment should be placed within convenient reach of the operator and at the same time well away (approximately 4 inches) from the grounded screening or metal bulkheads. The batteries must be kept above metal decks and the leads run directly and as short as possible. No two leads should be lashed together but are to be run separately and well supported.

Arrangement of instruments.

(9) The tests necessary to insure that the installation is operative were given in paragraphs (7), (8), (9), and (10), Article 31-927. The installer should lay particular stress upon the condition of surroundings in giving instructions to the operators. It is particularly desirable that a system of communication with the bridge be available in order that the bearings obtained by the compass may be intelligible, since they are dependent for their true direction upon the heading of the ship itself.

Test of installation.

PART 5.—INSTALLATION OF U. S. NAVAL RADIO COMPASS SHORE STATIONS.

31-929. The problem of deciding upon the location of a compass station merits considerable study. It should entail a thorough investigation of the local shipping, the relative position of existing compass stations or groups of stations and the military value of the proposed location. Thus, the placing of each station bears an important relationship to the entire compass system of that coast; and since the expense involved is considerable, the location selected should not be considered final until every factor has received attention. Should service requirements make imperative the placing of a station in an unfavorable locality from an electrical point of view a trial calibration should be made.

Establishment of location.

31-930. (1) The usual arrangement is a group of stations placed at the entrance of some port or harbor. The various stations in the group are interconnected by some method of communication to a control station having a radio transmitter. The stations in the groups take observations simultaneously upon the vessel requesting radio compass service. These observed bearings are transmitted to the vessel to be plotted by the navigator. The intersection indicates the position of the vessel at the time the obser-

Arrangement of stations in group.

vations were made. If there are more than two stations involved, the accuracy of the work will be indicated by the precision with which any bearing crosses the intersection of the other two.

(2) The accuracy with which the intersection of lines may be determined is some function of the angle between them. For acceptable results the angle between compass bearings should not be less than 20° . Since group stations are expected to give service up to distances of 100 miles, the condition is dictated that the separation between the extreme stations of the group be not less than 15 miles measured parallel to the coast line. With this base line, equal accuracy may be preserved up to within a mile or so of the coast. Local conditions may require that a third station be located in addition to the other two.

Uniformity of coast line.

31-931. Badly broken coast lines are to be avoided if smoother ones are available. Operation behind uniform level coast lines is much more consistent even though this desired condition only obtains within the immediate locality of the station.

Nature of surroundings.

31-932. Sites in the proximity of swamps or where conditions vary greatly with the weather are to be avoided. A large gully in the vicinity which is normally dry but which retains water after a rainfall will generally cause inconsistent deviations. Hills in the vicinity may produce excessive deviation as may deeply wooded sections or metallic veins in the earth. If any suspicion exists regarding such a location resort should be made to a trial calibration.

Proximity to metallic structures.

31-933. Any structure, the conductivity of which is indeterminate, will produce marked effects upon the operation of a radio compass within its vicinity. Under this category are communication lines, metallic towers or buildings, or even buildings containing electric wiring or piping. Two hundred feet, at the least, must separate the radio compass from any of the above, and in no case should the structure in question be between the compass and the sea within the working sector.

Visible points of reference.

31-934. The true meridian must be accurately determined at every station. The methods for obtaining this data are troublesome and rather involved when no reference points are visible. Considerable data may be obtained from the Coast and Geodetic Survey or the Hydrographic Office pertaining to numerous points of reference which have been established during their marine survey work. If any such points are visible from the station much future labor will be avoided.

Buildings required.

31-935. The structures which comprise a radio compass station include a compass house, quarters for the personnel, a power house, and a shed for fuel storage. Together with these will be considered in this chapter the antenna and underground cables.

Location of various buildings.

31-936. The distribution of the various structures will be influenced somewhat by the size and shape of the plot available. It is imperative, however, that the compass house be 200 feet to the seaward of any other structure on the reservation. The distance between the quarters, power house, and fuel shed should be about 50 feet in order to reduce fire risk. If an antenna is to be erected it should be at right angles to the coast line and centered over the power house.

31-937. Very specific plans and specifications have been prepared for the erection of the radio compass house. That every detail be as planned is most important, since the satisfactory operation of the equipment depends upon the proper surroundings. The design has been evolved from considerable experience and study and is not to be deviated from in any detail. The foundations should be carefully placed in order that there will be no settling or vibration during storms. No metal sheet nor strip is to be used in the construction of the roof or platform. Before the floor sills are placed a sufficient amount of underground cable must be buried at least a foot deep in a trench running under the house to a point directly under its entrance into the building. A proper length of cable end should be allowed to extend up through the floor of the house, with about a foot to spare for splicing. At the point where the cable leaves the ground a section of pipe must be sunk to ground water, a stout copper conductor attached to it and brought up with the cable ends. If it is found impossible to reach ground water the pipe should be omitted.

Construction
of radio compass
house.

31-938. (1) The standard plans provide that a complete shield be installed inclosing the portion of the building directly under the cupola. It is particularly important that attention be given the correct installation of this shield; all joints must be continuously soldered. The shield is to be protected after installation by an inside layer of finishing boards on the walls and partition. The partition finish is to extend 4 feet from the floor only in order that ventilation may be obtained. The communicating door is to be entirely covered with the screen, and flexible conductors provided around the hinges to the main screen. The shielding over the windows should be carried around the opening to the outside before the window framing is placed and then stretched tightly over it on the outside. The trapdoor to the loop compartment should not be omitted. Its covering of screen must make good contact to the ceiling shield by means of copper bearing strips. The ceiling shielding must be fitted thoroughly around the under side of the opening provided for the loop bearing.

Electromag-
netic shielding.

(2) After a suitable conductor has been carefully attached to the floor shield a covering of linoleum should be laid both inside of the shielded section and in the office.

31-939. It is absolutely essential that a good ground system be installed at the compass house by burying wires in a manner similar to that employed for transmitting stations, but not so extensively. The screening of the operating room is to be connected to the ground system at several points by carefully bonded joints.

Ground system.

31-940. Lead-and-armor cable is to be used for the underground stretches. A sufficient number of conductors must be provided to suit the conditions. Telephone or telegraph lines must be run in a separate cable from power or control lines. The cables should be buried one foot underground if possible and run in as straight a line as possible between the compass house and the power house.

Installation of
underground ca-
bles.

- Wave-length calibration.** 31-941. Two complete wave-length calibrations should be made and the results plotted on cross-section paper. Using the type SE 1440 receiver with 14 turns on the loop, the wave-length range with the compensating condenser set at zero should be from 500 to 1,000 meters. These values are approximate and dependent upon variations in the leads to the loop and in the receiver itself. This test should be made with the key switch on the receiver thrown to "compass." The SE 1012 receiver may now be set up and the number of turns on the loop reduced to 10. Several curves must be plotted for this receiver for the various secondary inductance taps. The "unilateral-bilateral" switch should be thrown to "bilateral" and the "tuned-untuned" switch to "tuned." During these calibrations the various steps of amplification should be tried. The driving source for the work may be a wavemeter placed on the floor of the loop compartment.
- Test for oscillations.** 31-942. A complete test should be made with both receivers for oscillations. No difficulty should be experienced in obtaining them on any inductance tap or at any point of the condenser. During the test for oscillations the loop should be orientated and no noises should be heard from poor contact in the slip rings.
- Test for minimum.** 31-943. If all tests of the receivers have been favorable, the amplification should be increased to a maximum and several bearings taken on any signals which may be heard. Two very distinct minima should be observed.
- Effectiveness of compensating condenser.** 31-944. When the tuning and compensating condensers have been carefully adjusted and with receiver oscillating, minima should be obtained on near-by transmitters not over one-tenth degree wide with complete silence in this region (assuming there is no interference). After the completion of the tests the SE 1440 receiver with 14 turns on the loop should be left as the standard arrangement.
- Communication instruments.** 31-945. Actual communication should be carried on to insure that the lines are operative.
- Record of equipment.** 31-946. A complete record should be made in Form N. Eng. 25A of the entire equipment, including type and serial numbers of the instruments, whether a complete set of spares has been provided, and any particulars which pertain to the installation and are at variance with standard.
- Performance data.** 31-947. Under this heading may be mentioned antenna radiation, character of minima, receiver calibrations, and any other data which will be of value for future comparison.
- General information regarding station.** 31-948. (1) A record should be made of the surrounding land, structures and their relative position, data pertaining to transportation facilities available, names of agents supplying fuel and supplies. This report is to be kept as a part of the files of that district, because much valuable time may often be saved if this information can quickly be obtained.
- (2) After the calibration of the station has been completed, the bearings of reference points employed during the work should be made a part of this report, thereby collecting all of the data pertaining to that station under one cover.

PART 6.—CALIBRATION OF SHIP RADIO COMPASS INSTALLATIONS.

General.

31-949. (1) The fact that the electromagnetic wave front is distorted in passing over a vessel's hull has been well established. The purpose of calibrating the radio compass on shipboard is to determine the magnitude of this distortion, technically known as deviation; also the direction in which the bending takes place, in order that these deviation values may be applied in subsequent operation of the radio compass. In practice these deviation values are the only correction that need be applied to radio-compass observations.

(2) Effective operation of the radio compass requires a certain amount of skill on the part of the observer, which can not be expected of an untrained man. This skill can be developed only by constant application of the proper operating methods.

(3) An idea of the utility of the radio compass should be borne in mind. The most important fact to be remembered is that the radio-compass bearings are relative bearings and that, in order to obtain the true bearing of a radio transmitting station, the heading of the vessel must be known. The present day radio compass on shipboard has reached such a stage of development as to be comparable in accuracy to other instruments indispensable to the navigator and its worth has been conclusively demonstrated under conditions as would render other navigation methods impotent. The potentiality of the radio compass as a military asset and as a device for locating vessels in distress has likewise been well established.

(4) As the effectiveness of future operation depends greatly upon the accuracy of the calibration, the necessity for painstaking care requires no further comment.

Method of calibrating.

31-950. The general scheme of calibration consists in the orientation of a radio transmitting station about the radio compass while simultaneous observations are taken both visually and by radio compass. It is assumed that the ambiguity of the radio compass (that is, the fact that two bearings, *approximately* 180° displaced are obtainable) is common knowledge. The fact that the two bearings are *only approximately* 180° displaced is the most important fact to be remembered. Therein lies the difficulty of utilizing the bilateral compass on shipboard, where the operating sector is 360° . This difficulty has been overcome by utilizing what is known as the half-scale method of calibration. To understand this method clearly, picture the calibrating vessel commencing her circuit of the vessel about to be calibrated at the bow and moving in a clockwise direction. From a position dead ahead to a position astern (0° to 180°) the radio compass bearings differ from the visual bearings only by the amount of the deviation. When the calibrating vessel has reached a radio compass bearing of 180° , the coil system is rotated to the region of 0° , and the bearing noted. This bearing, known as the reciprocal bearing, will not be exactly 0° when the direct bearing was 180° , due to the fact that the two minima are not exactly opposite. The calibration is continued in this manner on the port side of the vessel, the visual bearings of from 180° to 360°

corresponding to a second set of radio bearings of from 0° to 180° .

(2) In the above description the 180-degree sector to be used was selected arbitrarily, but in practice certain peculiarities of the station should be used as a guide in this selection. It will usually be found that one minimum is much sharper than the other, except at two opposite points, where the minima are practically alike. Between these points the sharper minima is always on the same side; i. e., with the grid end of the coil in the same general direction, regardless of the side from which the wave approaches. In general, the minima are poorest between these axes of symmetry and best in their general direction. On new type destroyers the axis of symmetry usually bears about 30° and 210° , the sharper minimum occurring when the grid end of the coil is toward the starboard side of the vessel. In this "sharper sector" less capacity is required for compensation, and it is the logical sector to adopt for a half-scale calibration.

(3) In this way only one of the two possible minima of the compass is utilized for the complete circuit of 360° , although there are two relative or true bearings corresponding to any radio bearing. In practice, it is impossible to determine the proper bearing from a single observation, except in coastwise sailing where, knowing the vessel's head, the proper bearing becomes evident. Where it is impossible to select the proper bearing, two observations must be made with a run between. The intersection of the two lines of bearing indicate the location of the transmitter.

Preliminary details requiring attention.

31-951. Previous to the actual calibration there are numerous details that require attention. It is most important that these be looked after so that no time will be lost during the calibration. The details may be considered under the general headings of installation and operation.

Installation defects.

31-952. The most common cases of installation defects, their effects and remedies, follow:

Battery leads in lead-covered wire.

(1) The battery leads to the receiver are frequently run in lead-covered wire, which covering is generally grounded. This results in greatly increasing the capacity to ground of these circuits.

Receiving apparatus installed near metal bulkheads.

(2) *It is imperative* that all radio compass circuits, both within the receiving cabinet, as well as the connection between the various pieces of apparatus comprising the unit, including also the batteries, be kept as far from the metallic hull of the vessel as is practicable. For this reason the connecting wires *must not* be encased in a metallic sheath. The batteries *must* be raised from the deck and set out from the bulkhead, and the receiver, especially the type SE 1440, which has a cabinet lined with sheet copper, must be kept at least 3 inches from the bulkhead. The leads from the compass coil necessarily pass into the brass shafting in order that the circuit be brought through the collector rings, but from this point they should be carried on column insulators down to the receiver.

Mast stays form closed circuit.

(3) Experiments have shown that if the athwartship stays of the main mast on destroyers are grounded at the deck and interconnected at the top the magnitude of the deviation will be

greatly increased, which is a bad feature. To cover this point the standard plans now call for the insertion of one porcelain insulator in each mast stay at the top, thus breaking up these loops.

(4) The top side of the after radio room on destroyers has been frequently used as a storage place for various metal drums, lockers, etc. The practice is a bad one and should be discouraged, as the presence of large metal objects near the coil may cause considerable deviation. When the vessel is under way the vibration of these objects, as well as the vibration of loose guardrails, will cause interfering noises in the receiving apparatus. A general inspection of all objects in the immediate vicinity of the compass coil housing should be made, and will undoubtedly amply repay the effort, as these disturbing features have frequently interfered with calibration.

Near-by metal
objects and loose
metal fittings.

31-953. (1) The most common defects in apparatus are:

- (a) Defective receivers and amplifiers.
- (b) Commutation (DC) noises.
- (c) Dirty collector rings.

Testing radio-
compass equip-
ment.

(2) Very thorough tests should be made of the receiving apparatus previous to calibrating, noting the control of oscillations or the presence of excessive noises in the telephones, particularly with receiver oscillating.

(3) A tuning calibration of the receiver should be made by coupling a wavemeter to the compass coil. Curves should be plotted and the tuning condenser dial of the receiver suitably marked. This tuning calibration is a very good method of testing the operation of the receiving apparatus.

(4) While testing the receiving apparatus the coil system should be rotated to note the condition of the collector rings. Dirty collector rings will cause very loud and grating noises in the telephones, especially with receiver oscillating. The rings may be cleaned with either an oiled rag or the fingers or, if seriously corroded, the use of crocus cloth is recommended. If these rings are thoroughly cleaned no noise will be heard while rotating the coil system.

(5) Following the tests of the receiver, the quality of the minima and the operation of the compensating condenser must be tested. Any powerful near-by radio station may be used for this purpose. In taking a bearing, whether during calibration or in subsequent operation, all antennas *must* be open—not grounded.

31-954. Previous mention has been made that two minima are obtainable on any particular signal, and the observer will notice that one of these is much more sharply defined. The coil system may be lined up manually. To do this, remove the top of the coil housing. The lead from the grid terminal of the receiver (the right-hand compass loop terminal to which the compensating condenser is attached) must be traced through to the coil winding. Turn the compass coil so that the grid end—i. e., the end to which this lead is attached—faces the starboard side of the vessel, with the plane of the winding fore and aft, estimating this alignment of the coil winding as closely as possible. The coil system is then held rigidly, the dial set screws loosened and the dial

Setting the
dial.

rotated until the 180-degree mark is directly in line with the pointer.

The dial may be more accurately set by directing the calibrating vessel to hold a position dead ahead, and send dashes for several minutes. The vessel need not lie exactly dead ahead—5 degrees either side of 0 degree (relative) will serve the purpose, provided her visual bearing is observed simultaneously with the radio. The compass observer selects the sharp minimum, the coil system is held rigidly on that bearing, and the dial is then adjusted to read 180°.

The next step is to blacken the section of the dial not to be used. This area will extend from 210° to 30° exactly, in a clockwise direction.

Planning the calibration.

31-955. (1) The calibration should be carefully planned, particular attention being given to the choice of personnel for observers. The next consideration is the type of calibrating vessel, or, to express it differently, the source of radio signals.

(2) This source may be either:

(a) A destroyer.

(b) A mine sweeper or tug.

(c) Any craft with radio transmitter over 1 kilowatt.

(d) A land station.

(3) The requirements of the source of signals are:

(a) Ability to withstand abnormally heavy duty, i. e., transmitting long dashes for several hours with high power.

(b) Ability to hold a clear note under above conditions.

(c) Sufficient power to give a sharp minimum on the radio compass to be calibrated. For this purpose transmitters under 1 kilowatt are not entirely satisfactory.

(d) Sharp tuning.

(e) Preferably the transmitter should have a spark frequency of 1,000 obtained from a 500-cycle transmitter.

(4) Whenever possible it is advisable to calibrate destroyers in pairs, each circling the other. Mine sweepers and tugs have been used with entire satisfaction; subchasers, on the other hand, usually prove unsatisfactory, as their power source is insufficient and not designed for continuously heavy duty.

(5) The use of land stations for calibration purposes is not urged, although they may be used if no other source is available. With a fixed transmitter it becomes necessary to swing the vessel. If sufficient care is exercised in swinging the vessel within a very restricted circle, this method should prove satisfactory.

Location suitable for calibration.

31-956. (1) Having selected the calibrating vessel, the next step is to select a suitable stretch of navigable water in which to perform the calibration. It is well to state here that it is impossible to calibrate the radio compass with the vessel tied up at the dock. When using a destroyer or other craft with a transmitter of 2 kilowatts or over as the calibrating vessel, the radius of the vessel's encircling course should preferably be not less than 4 miles. If the power of the transmitter is insufficient to give a minimum of one-half degree or less, the radius may be

reduced to 2 miles, although there is danger of considerable error at a short radius, due to the fact that it is difficult to determine the exact center of radiation of the calibrating vessel's antenna. To express this differently, the center of radiation of an antenna is not necessarily the lead-in. In fact, on the newer types of destroyers (with the inverted L antenna, main radio room forward) experimental data indicates the true center of radiation to be slightly forward of the bow. Thus, if the calibrating destroyer were brought within a radius of a mile or so from the compass and swung, using the lead-in of the main antenna as a pivot, the observed radio bearing would alternately increase and decrease, becoming correct only when head on or away from the compass. If swung with the bow as a pivot no appreciable variation of the radio bearing would be observable. When the calibrating vessel possesses a T antenna the lead-in may be assumed as the approximate center of radiation. Errors that may be appreciably great at a short radius become vanishingly small as this distance is increased. In the calibration of radio compass shore stations any possible error due to this condition is balanced out by making a reverse run, using the same visual target on the vessel, which may be a mast or a stack, for both runs. As time is usually not available in ship calibrations for such a degree of refinement, it becomes more essential to keep the radius large and to sight on a point as close to the true center of radiation as possible.

(2) Smooth water should preferably be chosen when performing the calibration, since the yawing or sudden swinging of the vessel to be calibrated may seriously interfere with the accuracy of both the compass and visual observations.

31-957. The instrument most commonly used for determining the visual or relative bearing is the pelorus. The general procedure is to use the two bridge peloruses, changing from one to the other to obtain an unobstructed view. It is most important that these peloruses be checked previous to calibration, as considerable errors in both peloruses have frequently been found. This method necessitates the use of a stadimeter or range finder with subsequent computation of parallax arising from the displacement of the radio compass installation and the bridge. Use of the pelorus.

31-958. The laborious procedure of computing parallax, as well as the possible errors arising from it, may be obviated by mounting a pelorus and stand on top of the radio compass coil housing. This method has been very successfully used—the obscured sectors due to the superstructure of the vessel and the mainmast are not extensive, and the angular increment of the calibrating vessel may be readily plotted against a time abscissa. Eliminating the computation of parallax.

31-959. Due to the numerous adjustments of the receiving apparatus and the possibility of interference from extraneous signals, compass observations can not always be made at a prescribed instant. The most reliable method is for the compass observer to give a "mark" signal the instant he has obtained the bearing, followed a second or so later by the value of the bearing in degrees and estimated half or quarter degrees. The "mark" signal should be relayed instantly through the voice tube to the The compass observer — mark system.

bridge by the assistant and the observed radio bearing recorded. On the bridge the "mark" signal must be repeated instantly by the assistant to the pelorus observer, who is standing by. The pelorus observer having obtained his bearing, to a half or quarter degree, greater accuracy not being required, informs his assistant, who in turn relays the data through the voice tube to the recorder. This plan has been used satisfactorily during many calibrations. It requires quick action by all hands and a short drill immediately preceding the actual calibration will insure perfect cooperation.

TABLE I.—*Radiocompass calibration data form.*

Calibration of U. S. S. _____ Sheet No. _____
 Calibrating vessel _____ Date. _____
 Radio OBS _____ Pelorus OBS _____

Radio.	Pelorus.	Corrected pelorus.	Compen-sator.	Radio.	Pelorus.	Corrected pelorus.	Compen-sator.

(2) If the pelorus is mounted on top of the compass coil housing, the assistant may conveniently stand on the deck to relay the "mark" signal from the compass observer to the pelorus observer and take down the data. With this method, as the calibrating vessel is approaching or emerging from either obscured sector, the pelorus observer should inform the data recorder, so that the time, in minutes and seconds, at which the observations were made may be recorded. The time at which the radio bearings are observed, within the obscured sector, should, of course, be noted and plotted.

Speed of cali-
brating vessel.

31-960. The angular velocity of the calibrating vessel and the rate of taking bearings are important considerations. It has been found that the most satisfactory results are obtained when the calibrating vessel moves at a rate of approximately 2 degrees in a minute of time. At this rate the entire circuit may be made in three hours. A greater rate increases the possibility of observational inaccuracies and a lesser rate consumes more time than is actually necessary. A radio compass observer should bear in mind the fact that a few good bearings are vastly superior to a multitude of scattered ones. Under normal conditions he should be able to average one to two observations in a minute of time.

Instructions
for calibrating
vessel.

31-961. A complete understanding should be had with those on board the calibrating vessel. A radius of the calibrating vessel's course should be laid down, as well as her speed. Her radio operator should be instructed to send, continuously, dashes

of 10 seconds duration with an interval of 5 seconds for a period of 10 minutes, followed by a 1-minute interval of listening for any communication, repeating this performance until further instructed. Some calibrators prefer the MO signals, others the letter J. The type of signal to be used is optional, provided the spaces between the signals are not too great. The radio operator should endeavor to keep the radiation constant and the *note clear*. If for any reason the transmitter should become inoperative he should notify the navigation officer to stand by until repairs have been made. In continuously heavy duty of this character it is advisable to cool the spark gap with a fan.

31-962. A summary of the important details connected with the preparation for calibration follows:

Summary of
important de-
tails.

(1) The wiring of all connecting leads and the disposition of apparatus must be such as to give the minimum capacity to ground.

(2) No metallic closed loops, such as are formed by interconnected mast stays, should exist in the vicinity of compass coil.

(3) All metal objects of appreciable dimensions should be removed from the immediate vicinity of the compass coil and the rat-tail of the auxiliary antenna must be securely held in a permanent position.

(4) The receiver must be functioning properly both in control of oscillations and of amplification and be free from excessive telephone noises.

(5) The loop inductance switch (SE 1512 compass) must be in good condition. This is evidenced by the receiver calibration.

(6) The sharper of the two minima is to be selected as the pointer.

(7) The dial is to be properly adjusted and the scale from 210 to 30 degrees painted black.

(8) The bridge peloruses must be checked, or if the pelorus is placed on top of the coil housing it must be properly set up.

(9) A means of communication between the compass observer and the pelorus observer must be established, with assistants advantageously placed to relay the mark signals.

(10) The "mark" system should be understood by all hands, and the assistant nearest the compass observer entrusted with the duty of recording the data.

(11) Instructions should be given the navigator and radio operator of the calibrating vessel concerning the duties they are to perform.

(12) During the calibration *all* antennas on the vessel *must be open*.

31-963. The calibration may be begun on any convenient quarter. However, if the calibrating vessel can be held for a few moments on a position either dead ahead or astern, the setting of the dial may be performed more accurately than by the manual method. The reason the dial is best set on either of these two positions is that the deviation curve passes through zero (i. e., there is no deviation) close to these two points and there the dial may be set to correspond with the pelorus reading and also

Setting the
dial.

because there is no appreciable parallax, if bridge peloruses are used. When time is not available for this procedure, the calibration may be run, data plotted, and dial afterwards shifted sufficiently to balance the deviation equally on both sides of the zero axis. This requires considerable care, since the results of the entire calibration may be ruined by incorrectly placing the dial.

Example of calibration.

31-964. (1) As an example of the calibrating procedure, using the half-scale method, consider the calibrating vessel starting her circuit at a relative bearing of 0° . The zero section of the radio compass dial is painted black. However, a compass bearing will be obtainable in the region of 180° on the dial. At the instant of obtaining the radio bearing the observer calls "mark"—the assistant relays the "mark" to the pelorus observer—the radio compass observer calls off the bearing in degrees and estimated fractions (half or quarter degrees)—the recorder writes this down in the proper column of form shown in Table I. Meanwhile the pelorus observer takes his observation (to the nearest half or quarter degree) and relays the bearing (through his assistants) to the data recorder, who writes down the pelorus observation in the proper column adjacent to the corresponding radio bearing. With a little practice this system may be worked easily and without confusion. Ten seconds should be ample time to obtain and record a single bearing. Should any confusion arise, the questionable bearing must be eliminated.

(2) This procedure is then carried on until the calibrating vessel has reached a radio bearing of 210° (or over). When the observed bearing falls on the blackened section of the dial, the coil must always be reversed, and the reciprocal bearing used. If the last observed radio bearing was 210° , the reciprocal bearing will be found in the vicinity of 30° .

(3) The calibration is then continued, using dial reading from 30° on, until the observed radio bearing once more falls on the blackened scale at 210° , corresponding to the calibrating vessel's relative position of approximately 210° . As the vessel continues to advance beyond this point the coil system must once more be reversed and, as the vessel continues from 210° to 360° , relative bearing, the corresponding radio compass readings will advance from 30° to 180° , approximately.

(4) The variation of the compensating condenser should be noted and recorded. These observations (in degrees) may be recorded at about every 10° of azimuth.

Communicating with calibrating vessel.

31-965. During the calibration the radio compass observer may communicate with the calibrating vessel whenever necessary, using the auxiliary radio transmitter.

The calibration curve.

31-966. The data may best be plotted in the form of a curve. The large size cross-section paper (10 lines to the inch) is suitable, 18 spaces being required for the abscissa (radio compass bearing) and 37 spaces for the ordinate (relative bearing). When the paper has been properly drawn up and the degrees marked, the observed points may be placed in position. Begin at the first observed radio bearing on data sheet and note its value and

the corresponding pelorus reading (corrected pelorus reading if the bridge pelorus has been used.) Next, place a point on the cross-section paper at the exact intersection of the lines corresponding to these values of radio compass and relative (pelorus) bearings. Continue placing these points until all the observations have been recorded. A curve may then be drawn (with the aid of a French curve) through the average of these observed points. The closeness with which these points adhere to this line is an indication of the accuracy with which both sets of observations have been made. This curve represents the deviation of the radio compass. Curves showing variation of the compensating condenser should be plotted, using the observed bearing as the abscissa, as in the plotting of the deviation curve.

31-967. (1) The next step is to make up a typewritten form ^{The correction sheet.} of deviation values, as shown in Table II. The corresponding relative bearings (two) for every radio compass bearing are to be obtained by noting where the vertical line corresponding to the particular radio compass bearing intersects the curved lines which have been drawn through the average of the plotted points. At the *exact intersections* the corresponding relative bearings (two) whose horizontal lines intersect the curves must be noted and recorded as in Table II. This is to be done for each degree (compass bearings).

(2) When this has been completed, copies should be placed in the ship's files, a copy placed conspicuously in the compass radio room and a copy forwarded to the Bureau of Engineering, accompanied by a copy of the calibration and compensation curves, together with a complete report describing all the features of the calibration.

(3) The radio compass is now ready for subsequent operation.

TABLE II.—*Correction sheets for radio compass bearings.*

U. S. S.----- Calibrated-----

Observed bearing.	Relative bearings.			Observed bearing.	Relative bearings.	
	No. 1.	No. 2.			No. 1.	No. 2.

PART 7.—CALIBRATION OF U. S. NAVAL RADIO COMPASS SHORE STATIONS.

31-968. (1) The necessity for the calibration of the radio compass, whether installed on shipboard or on shore, arises from the fact that certain deviations are observed between the true bearing and the radio compass bearing when rotating the loop through its azimuth. Repeated tests have shown that these deviations

General.

have, normally, a constant value when the incoming signal is within a certain band of wave lengths, and that the radio compass can be relied upon to give accurate bearings when properly corrected by a table of deviation values to be applied to the radio compass values. The procedure is to rotate a radio transmitter about the radio compass to be calibrated, taking simultaneous readings of both true and radio compass bearings.

(2) The two most important facts to be kept in mind in planning any calibration are, first, the reliability of the personnel and, second, the perfect cooperation between the ship and the calibrating party ashore. The duties of the radio compass observer and the transit observer demand men in whom reliance with regard to accuracy as observers and conscientious performance of duty can be placed. In the case of a station already in commission it is well to utilize the personnel attached to the station whenever possible. The officer in charge of the particular station, usually a chief radioman, can in most cases be considered an efficient radio compass observer. Thus a twofold benefit is derived, namely, the necessity of transporting a trained man from the radio material office is obviated, and the officer in charge of the station is made much more familiar with the operation of his station throughout its entire azimuth. This also is conducive toward a greater interest in his own station. The other operators may generally be utilized as data recorders, or in the lines of communication. The transit man, on the other hand, is usually not to be found among the station personnel, and for this position a man thoroughly familiar with the operation of the transit (or theodolite) is essential.

(3) The necessity for cooperation between the ship and the calibrating party ashore should be emphasized. Experience has shown that unsatisfactory results, as well as long delays, have been caused by the commanding officers of the calibrating vessels misconstruing instructions and at times not complying with requests that were deemed essential by the calibrating party. Official orders should be issued by the commandant of the navy yard to the commanding officer of the vessel, when this officer reports for duty, that during the period of actual calibration the vessel is to be maneuvered in accordance with the requests of the person in charge of the calibrating party; however, throughout the calibration the responsibility of keeping the vessel in safe waters remains, in accordance with navy regulations, upon the commanding officer.

Calibration of
receiver.

31-969. In case the receiving apparatus has not been calibrated at the time of installation, the wave-length range of the receiver, with extreme limits of compensating condenser, also with different taps of inductance when using the type SE 1012 receiver, should be measured with a wavemeter coupled to the radio-compass coil, and curves plotted for the information of the operating personnel.

Communication
instruments.

31-970. All land lines must be completely installed and in operating condition previous to calibration. All radio antennas should be erected and proper precautions taken to insure that the antennas are disconnected at all times by means of the

standard anchor gap, and that the transmitting apparatus is in working order.

31-971. The vessel should be moved to a position approximately at right angles to the shore line. If the vessel is head on to the radio compass house in this position there will be normally very little deviation in the wave front, and the true bearing as observed by the transit may be used as the setting for the radio compass dial. In certain cases a fixed radio transmitting station, preferably one from which the signals travel entirely over water, may also be conveniently used for this purpose, providing the signal intensity is sufficient to give a good minimum. Setting the dial.

31-972. While there have been cases in which two men have successfully accomplished the calibration of a radio compass station, it is not a good policy to attempt to thrust too many duties on any one man in work of this nature. The following personnel generally constitute the calibrating party: The calibrating party.

- The executive (plotter).
- The radio compass observer.
- The transit observer (two required in obscured sector).
- The data recorder.

Two radio operators are required in obscured sector.

31-973. The following list of material will be needed: Material required.

- One transit or theodolite (two for obscured sector).
- One three-arm protractor (for use in obscured sector).
- Several large scale Coast and Geodetic charts.
- Cross-section paper for deviation curves. Form N. Eng. 29 (see articles 31-977 and 31-978).

Data forms.

French curves, pads and pencils.

India ink, drawing instruments, and bottle of clear lacquer.

Two radio receivers and portable antennas for use in the obscured sector.

31-974. The following directions should be given the radio operator on the vessel: Directions given to operator on calibrating vessel.

(1) Previous to starting the run, tests are to be made for tuning, wave length, clarity of note, and requisite power, followed by tests for the setting of the dial at the radio compass station. The vessel to send continuous dashes of ten seconds duration with five-second intervals for five minutes, followed by a one-minute period of listening for communications from the radio compass station. If no messages are received the above schedule is to be repeated. All radio messages are to be promptly forwarded to the commanding officer. The same transmitting schedule is to be followed in the running calibration.

(2) In the obscured sector, when informed by the commanding officer that the vessel is on position, he notifies the compass station and stands by until ordered to transmit. Every test on each position should contain a prefix stating the serial letter for the sector and serial number for the particular test. The commanding officer will keep the radio operator informed of the position.

(3) On fixed positions the transmitting schedule will be the customary ten-second dashes for a period of three minutes, fol-

lowed by listening in for one minute, continued until notified by the radio compass station to proceed to next position, when he shall relay the information to the commanding officer and stand by for next position. This procedure is to be followed throughout the obscured sector.

(4) In case of breakdown in the radio transmitter, the operator should notify the commanding officer at once, so that the vessel may lay to until the transmitter has been repaired.

(5) The operator should give particular attention to the spark tone and the radiation, endeavoring to keep these constant at all times.

(6) All messages relating to the calibration will be treated as official.

(7) Written directions covering all these features should be given the radio operator.

The calibrating vessel.

31-975. (1) The selection of the proper type of vessel is an important consideration. It is an important policy to request the assignment of destroyers for this work whenever practicable; however, other vessels, such as tugs and mine sweepers, have been used. Subchasers have proven unreliable, first because the radio transmitter lacks sufficient power and their direct current generating system is not designed for continuous duty; second, because the subchaser presents a poor target for the transit.

(2) The transmitter on the calibrating ship should be capable of withstanding abnormally heavy duty. Preferably the apparatus should be a 500-cycle quenched gap transmitter, power rating not less than 2 kilowatts, able to maintain a clear note under continuous operating conditions. The apparatus must be carefully tuned to the calibrating wave length. The radio compass operating wave length for shore stations established for the United States is *800 meters*.

(3) To insure complete cooperation, it is always advisable to familiarize the commanding officer of the vessel with the details of the calibration. In conference with him, the calibrating course of the vessel is to be settled and marked on the chart. As the nature of the coast varies greatly with different localities, it is impossible to promulgate a definite plan for the course of the vessel. However, the following features are important:

(a) The vessel must be visible from the compass station, or, in the case of the obscured sector, from the triangulation points.

(b) The optimum radius of the circle is approximately 5 miles.

(c) As viewed from the compass station, the vessel should move with an angular advance of not greater than 2° in a minute of time.

(d) During the continuous calibration, at the end of the visible sector course, the vessel reverses her direction, repeating the run to balance out any errors due to time lag between compass-transit readings and to the fact that the center of radiation of the vessel's antenna is not necessarily the lead-in.

(e) In the obscured sector the vessel is to hold to fixed positions headed toward the radio compass station. The positions to be not greater than 5 degrees apart as viewed from the radio

compass station. Each fix will require three minutes of time for transmitting. If there is more than one obscured sector it is advisable to letter each sector serially and to number each position serially.

(f) The searchlight may be used advantageously in thick weather. Its rays can be clearly seen at times when the ship is entirely obscured.

(g) In particular cases when the vessel can not operate within visible range of the compass station due to shallow water, the calibration may be satisfactorily performed at night, using the searchlight.

31-976. (1) The visible sector should always be calibrated first, making both runs. This shows what may be expected in the obscured sector. When shifting from visible to obscured sector, or between two obscured sectors, an overlapping of sectors is advisable in order that an accurate check on the triangulation set up may be obtained.

Procedure.

(2) In the obscured sector the mark system is handled by radio from the compass station. When proceeding to obtain a bearing a "get ready" signal, two dots, is given by the observer at the radio compass, then a long dash when bearing is obtained, followed by a serial number repeated several times. To prevent interference from these signals the transmitter should be tuned to a wave other than the calibrating wave. This procedure is advisable because, unless anchored, the wind or tide may carry the vessel along rapidly.

(3) Should a sudden change of deviation value be observed, the procedure in seeking the cause of this trouble is as follows:

- (a) Recheck transit set up on landmarks.
- (b) Test "peep sight" alignment of coil system.
- (c) Note any possibility of grounds or open circuits in the wiring of the apparatus.
- (d) Investigate any possible change in communication lines, also the antenna system at the station if there be one.

(4) During the calibration of the obscured sector, if the deviation values fail to fall on the curve, it is advisable to obtain additional points between those previously obtained.

31-977. During the running calibration the divergence of the radio compass bearing from the true bearing should be plotted in the form of a deviation curve, using Form N. Eng. 29. When the radio compass bearing is greater than the true bearing, the deviation is considered negative. The value of this deviation is the ordinate while the abscissa is the radio bearing for this particular observation. Distinctive markings should be used in plotting the two courses of the ship.

Plotting the data (visible sector).

31-978. The data obtained from the compass and transit observations should be each averaged for every fixed position and plotted on a large-scale chart with a protractor. To do this, the protractor is set on a true meridian running through the triangulation point; the moving arm is then adjusted to correspond to the average of the transit readings for the particular position

Plotting the data (obscured sector).

of the ship and a pencil line drawn on the chart. This operation is repeated from the other triangulation point, and the resulting intersections marked with the proper serial letter. The protractor is then set on the radio compass station in the same manner and the true bearing of the intersection read directly from the protractor. The deviation of the radio bearing at this angle is plotted as in the visible sector. In case the position of the vessel is determined from sextant angles, the three-arm protractor must be used to mark the location on the chart.

**Compensating
condenser varia-
tion curve.**

31-979. A curve showing the variation of the compensating condenser in degrees over the calibrated sector should be plotted. This curve may prove of value in a theoretical study of the deviation curve and may also be used as a guide in the future operation of the station. This variation curve may conveniently be plotted with the deviation curve, using Form N. Eng. 29. The two curves should be distinctly marked.

**Report of cali-
bration.**

31-980. A report incorporating all the features of the calibration should be written and submitted to the district radio material officer. The deviation curves incorporated should contain the points indicating the values obtained. This report should include a complete description of surrounding conditions (topography); also, in the case of a subsequent calibration of the same station, any changes in topography or overhead wiring, etc., should be noted.

PART 8.—OPERATION.

General.

31-981. The operation of the radio compass in taking a bearing is the same whether it is a ship or shore installation. The same procedure is followed when taking a bearing with a calibrated radio compass as when calibrating. The deviation of the radio compass was determined during the calibration and the curve drawn. In that case the bearing of the transmitter was taken visually. After calibration entire dependence is placed in the calibration in order to find the bearing of the transmitter without resort, of course, to any visual means. It is therefore necessary that the deviation as found during the calibration be applied to the bearings read on the radio compass dial in conjunction with the bearing of the ships ahead. The result will be the true bearing of the transmitter from north (zero degrees).

**Procedure in
taking bearing.**

31-982. Bearings should invariably be taken in accordance with the following procedure:

(1) Take bearing preferably with clear tone signal, or else full oscillating condition. With receiver oscillating, the minima are much more sharply defined. However, interference will obscure an otherwise good minimum, because tonal selectivity is lost.

(2) Tune signal carefully, with coil system at or near the maximum.

(3) Rotate coil system through the null point of the signal, oscillating to and fro, finally coming to rest at estimated center of the "minimum."

(4) Adjust compensating condenser *carefully*, in the same manner as the coil system is rotated, seeking the exact center of the "minimum."

(5) Retune carefully. (Always tune with compass coil *off* the minimum.)

(6) Repeat 3.

(7) Repeat 4. This operation is now to be repeated in conjunction with the rotation of the coil system. The final adjustment of compensating condenser and coil should give a point of silence on some particular bearing. It is well to note here that there are some compass stations at which absolutely silent minima are unobtainable, although these minima are exceedingly sharp and the station operation is excellent. The width of the zone of silence depends on the power of the transmitter, the distance of the transmitter, and the sensitivity of the receiver.

31-983. The following precautions should be observed:

Precautions.

(1) Never attempt to obtain bearing with receiver regenerating or barely oscillating, as in this condition the circuit is very sensitive to any changes in its decrement which will result from the adjustment of either tuning condenser or compensating condenser. Due to the variation in signal intensity resulting from these changes proper operation will be difficult. If signal intensity is low, regeneration should be used after all adjustments of tuning and compensation have been made.

(2) Adjust tuning condenser for maximum signal intensity. All tuning *must* be done with the coil off the minimum. Incorrectly tuned circuits will result in erroneous bearings.

(3) Do not swing coil through a large arc. Ten degrees either side of null point is sufficient at start; after retuning and re-compensating, the swinging of the coil should be further restricted to about 1 to 3 degrees on either side of null point, depending on the sharpness of the minimum.

(4) At stations where compensating condenser values change greatly throughout the azimuth the detuning may be considerable. Therefore the necessity for retuning is important.

(5) When coil system and compensating condenser have been successively adjusted to give a silent point, the entire attention may be devoted to the coil system. The coil system should be slowly rotated within restricted arc, careful attention being given to estimating the true center of the minimum.

PART 9.—FAULTS AND REMEDIES.

31-984. Should the compass station be a new one and difficulties ensue during the calibration, the remedies outlined in the following should remove the difficulty. On the other hand, if the previous calibration of the particular station has proved satisfactory and good minima have been obtained throughout the operating sector, it is but reasonable to expect the station to continue to operate in the same manner. If, however, a considerable change in the quality of the minima throughout the operating sector or in any particular part of the sector should be experienced, the following remedies are to be studied and applied.

General.

Defects of minima.**(1) BROAD WITH RESIDUAL SIGNAL.**

Possible causes.—(a) No compensation (open circuit).

(b) Near-by grounded antenna.

(c) Communication lines not drained.

(d) Grounding of radio compass apparatus, wiring or batteries.

(e) Moisture on coil windings, or terminal ring.

(f) Weak signals.

(g) Faulty screening of operating room.

Remedies.—(a) Overhaul wiring, particularly compensating condenser connections.

(b) Note condition of anchor gap in antenna lead. This should be open. Test across this gap with battery and buzzer.

(c) All communication lines should be adequately drained of radio-frequency current by means of 1 μ f condensers.

(d) (e) Test insulation of radio-compass circuits for grounds.

(f) Broad minima are caused by weak signals.

(g) The screening of the operating room must be kept intact. This is very important at certain compass stations. On ships the room is usually built of metal.

(2) BROAD WITHOUT RESIDUAL SIGNAL.

Possible causes.—(a) Insufficient power at transmitter.

(b) Transmitter beyond normal working range.

(c) No oscillations or amplification.

Remedies.—(a) (b) The normal operating range of SE 515A radio compass is from 100 to 150 miles with 2-kilowatt transmitter, the SE 1512 and SE 995 considerably less. When signals from 2-kilowatt transmitter are silent over a dial reading of about 2°, the transmitter is beyond the normal working range of station.

(3) VERY SHARPLY DEFINED.

Possible causes.—(a) Transmitter with excessive power.

(b) Transmitter very near at hand.

(c) Excessive amplification.

Remedies.—(a) (b) This condition is not considered as unfavorable. In fact, it contains all that is desirable in radio compass operation. During calibration of a shore station the calibrating vessel usually transmits with 5 kilowatts, keeping a radius of 5 miles. This results in a minimum about one-half of a degree in width. If, however, the calibrating vessel approaches the compass station to within a radius of a mile or so, the minimum may be so sharply defined as to be scarcely obtainable; in fact, merely touching the compass wheel may result in a tremendous change in signal intensity.

(c) Amplification may be reduced.

(4) VARYING DEGREES OF SHARPNESS THROUGH AZIMUTH.

Possible causes.—(a) Grounded antenna near by.

(b) Communication lines not drained.

(c) Location of station.

(d) Closed metallic loops near by.

Remedies.—(a) (b) To a certain degree slight variations in the quality of the minima are found at all compass stations. If this defect should become very pronounced, it may be concluded

that the trouble is purely local. Test antenna. Test communication lines.

(c) See articles 31-931, 31-932, and 31-933.

(d) All mast stays near compass coil should be insulated, preferably at the top. (See article 31-929.)

(5) STATIONARY (ERRONEOUS BEARINGS).

Possible causes.—(a) Near-by grounded antenna.

(b) Communication lines not drained.

(c) Closed metallic loops near by.

Remedies.—(a) (b) With near-by grounded antenna, especially if tuned to particular wave lengths, the compass will point to antenna, due to its reradiation. This is prevalent on shipboard. Undrained communication lines have been the source of stationary minima at shore stations. (See par. 4 (a, b).)

(c) See paragraph 4 (d).

(6) APPARENT SHIFT OF (ERRONEOUS BEARINGS).

Possible causes.—(a) Mechanical slip in coil system.

(b) Communication lines not drained.

(c) Grounded antenna near by.

(d) Grounding of R. C. circuit wiring or batteries.

(e) Diurnal variations of fixed transmitting station.

(f) Diurnal variations at compass stations.

(g) Faulty screening.

(h) Improper operation.

Remedies.—(a) Test coil system alignment with peep sights. This slip may occur at (1) the center casting, (2) the shaft coupling, (3) the dial, (4) the hairline indicator. Any slip will give a constant error for all bearings.

(b) (c) See paragraph 4 (a, b).

(d) Test.

(e) This is a research problem at present being studied. Certain variations in the bearings of fixed transmitting stations have been observed, although it is difficult to differentiate between the variations in the transmitter and those prevailing at the compass station. (See (f).)

(f) Experiments indicate that bearings on fixed transmitting stations within the operating range and situated at points where no land intervenes remain constant to within one degree. Bearings on fixed transmitting station over land and particularly when tangent to the coast line are subject to some diurnal variations. (See par. 10 (c) (d).)

(g) See paragraphs 1 (g), 10 (e).

(h) Study operating instructions carefully.

(7) NOT OPPOSITE (180° displacement).

Possible causes.—(a) Extraneous in-phase current in compass coil.

Remedies.—(a) The ideal condition of having the two minima exactly opposite is seldom found. A displacement of 3 degrees is not considered abnormal; however, if displacement exceeds this value the operation of the station becomes questionable, as this indicates an excessive amount of extraneous in-phase current is being induced into the coil system, which effect is subject to

some variation. The amount of this displacement will vary throughout the azimuth. Test antenna, paragraph 1 (b). Test communication lines.

(8) EFFECT OF INTERFERENCE ON.

Possible causes.—(a) Receiver oscillating.

Remedies.—(a) With the receiver oscillating, the tonal selectivity of signals is lost, making it most difficult to obtain minima on any particular signal through interference. The best method for overcoming this is to set receiver into regenerative condition (clear signals) and boost amplification to highest point. NOTE: Care must be exercised in this condition when adjusting the compensating condenser, because the tuning of the circuit is affected, which, in turn, is intimately connected with the points at which the receiver will oscillate. It is best first to loosen the back coupling, tune signal, compensate, retune, recompensate, then advance to regenerative state if signals are weak. A large change in back coupling will affect the tuning of the circuit for very short waves, but is in unappreciable with the standard compass equipment for 800 meters.

(9) EFFECT OF INTERFERENCE ON (TELEPHONE NOISES).

Possible causes.—(a) Defect due to compass coil, receiver, amplifier, telephones, batteries, connections, or extraneous causes.

Remedies.—(a) Loud telephone noises may be a source of great annoyance and fatigue to the operator, resulting in erroneous bearings. They must be eliminated.

(10) VARIATION OF COMPENSATING CONDENSER VALUES FOR A GIVEN AZIMUTH.

Possible causes.—(a) Grounded antenna near by.

(b) Communication lines not drained.

(c) Diurnal variations at station.

(d) Tuning of transmitter.

(e) Condition of screening.

Remedies.—(a) (b) Test antenna, paragraph 1 (b). Test communication lines.

(c) The compensation values for particular azimuths do not remain absolutely constant, but vary within restricted limits, due to changing conditions in the surrounding bodies, chiefly caused by the degree of moisture in the air or on the surface of the ground. Considerable change in the deviation curve and compensation values between the two extremes of very dry and very wet spells of weather has been observed at some compass stations. The importance of having a permanent ground connection at the compass station must not be overlooked. Then, too, at compass stations where the compensation values are sharply defined, which is associated with sharp minima, the capacity of the operator's body becomes very apparent, and changes, such as lifting or lowering the feet, may affect the compensation to a noticeable degree.

(d) The type of transmitter on which the bearing is being obtained may noticeably affect the compensation values. There are, in fact, certain types of transmitters on which it is impossible to obtain bearings; these are likewise unresponsive to adjustments of the compensating condenser. (See par. 6 (e, f)).

(e) Any radical change in the condition of the operating room screening may affect the compensation and also the deviation. This is more apparent at certain compass stations. The screenings should be kept intact and frequently inspected.

31-985. Compass coil defects, in general, may be considered as mostly mechanical. The construction of the various parts comprising the coil system should be thoroughly studied. The electrical defects that can possibly develop in the coil system may be readily located. These defects and their remedies are listed below:

Defects in the
compass coil.

(1) NOISE IN TELEPHONES ONLY WHEN ROTATING THE COMPASS COIL.

Possible causes.—(a) Rough, dirty collector rings.

(b) Loose contacts at binding posts on terminal strip.

(c) Loose, dirty ball bearings.

Remedies.—(a) Rough collector rings should be smoothed with finest sandpaper and polished with crocus cloth. They should occasionally be given a touch of light oil and rubbed dry. There is a tendency for the two metals to tear, thus leaving a fine deposit of metal upon the ring. This should be carefully removed with an oiled rag or fingers, by rotating the coil system, and then dried.

(b) The brass binding posts have a tendency to corrode and at times loosen, causing poor contact with conductor. Any vibration or rapid rotation of coil system will produce a chattering under these conditions, particularly if the receiver is oscillating. They should be removed and dipped in acid, replaced and greased.

(c) Bearings should be tightened and kept well greased. If they have been allowed to dry out and become roughened, they should be replaced. The coil shaft is connected to ground through these ball bearings, and if their condition is such as to cause noises in the telephones, they may be shorted by means of a flexible conductor wound around the coil shaft. This trouble is seldom encountered.

(2) NOISE IN TELEPHONES NOT DUE TO ROTATION.

Possible causes.—(a) Vibrating near-by metal bodies.

(b) Defects in the receiver, amplifier or telephones.

(c) Arc mush.

(d) Audio-frequency induction.

Remedies.—(a) This condition is found chiefly on ships, and may be caused by the vibration of metal objects, such as guard rails, provision lockers, loose guy wires, etc., in the immediate vicinity of the compass coil. These objects should be located and grounded or insulated, as the case may be. It is imperative that all such objects be kept in constant condition after the compass has been calibrated, as any radical changes will affect the deviation.

(b) See Section VI (A), (B), and (G).

(c) This is unavoidable and is very pronounced in the vicinity of high-power arc transmitters.

(d) This is rarely obtained on the compass coil. (Bearings on induction are seldom obtainable.) It is more frequently picked up by the apparatus or connecting leads.

(3) NO OSCILLATIONS IN CERTAIN SECTORS.

Possible causes.—(a) Coupling to near-by metallic circuit.

(b) Grounded near-by antenna.

(c) Undrained communication lines.

Remedies.—(a) This is occasionally found on ship installations, and should be remedied previous to calibration, as it will affect the deviation. The immediate vicinity of the coil must be explored until the particular circuit is located and insulated. Any metallic stays in the immediate region of the compass coil must be broken up with insulators, preferably at the top. In general, there must be no closed metallic loop of large dimension in the vicinity of the compass coil.

(b) (c) Test. (See par. 1 (b) (c).)

(4) SLIP IN COIL SYSTEM.

Possible causes.—(a) Loose center casting.

(b) Loose coil shaft coupling.

(c) Loose dial.

(d) Loose hair-line indicator.

(e) Loose wheel.

Remedies.—(a) (b) (c) (d) (e) All these parts have through bolts or set screws or both. Tests should be frequently made of their condition by a sudden torque of the compass wheel, followed by an investigation of the peep-sight alignment. (See par. 6 (a).)

(5) SEVERE BINDING OF COIL SYSTEM OR SCRAPING OF HAIR-LINE INDICATOR ON DIAL.

Possible causes.—(a) Ball bearings dry, dirty, tight.

(b) Table bearing tight due to tearing of bearing surfaces.

(c) Dial out of line.

(d) Hair-line indicator panel too close to dial.

Remedies.—(a) The ball bearing races should be kept clean and well greased.

(b) Drop some heavy oil into bearing and work slowly. If no improvement, disassemble coil shaft system below coupling and rub down end of shaft with sandpaper, replace and oil.

(c) The type SE 515A dials may be thrown out of level by leaning heavily on one side. To test, remove hair-line indicator panel and rotate coil system, noting the rise and fall of lower edge of dial. This may be removed by pressing down on the high side and lifting on the low side. Replace hair-line indicator panel.

(d) To minimize any errors due to parallax, the hair line should be held as close to dial as is practical, avoiding any scraping. If too close, the panel may be packed out with thin sheet metal or paper.

Defects in the receiver and amplifier.

31-986. Radio compass receiver and amplifier troubles may be readily located by anyone who has had some general experience with radio receiving apparatus. The compass coil system may be treated simply as a large inductance inserted in series with the secondary inductance contained within the receiver. Any troubles

that may develop, such as lack of signals, howling, etc., may be treated as in an ordinary receiving set.

PART 10.—TESTING OF CIRCUITS AND APPARATUS.

31-987. Testing of the receiving qualities of the radio compass equipment may best be performed with a wavemeter. ^{Use of wave-}
 Place the wavemeter in close proximity to the compass coil, allowing clear-^{meter.}
 ance for rotation of coil system to obtain proper coupling; adjust wavemeter to proper wave length (800 meters) and start buzzer. In this manner the signal intensity, tuning of the coil system, control of oscillations, and control of amplification may be tested. Should there be no response, note if all switches are thrown to proper positions, tubes lighted, all wiring connected, etc. Test telephones with low-voltage battery for characteristic click. To test continuity of all circuits, the telephones and battery or buzzer are very useful.

31-988. (1) Disconnect leads at receiver. If circuit is open, ^{Open circuits}
 the characteristic click in telephones will be absent. Look for ^{in compass coil.}
 (a) open "ground switch" (SE 995 installation (b) open or short at the protective relay (SE 995, SE 1512 installation), (c) open "loop inductance switch" in switch housing on top end of coil shaft (SE-1512 installation). (d) open at terminal block, collector rings and contactors (all types of installation).

(2) Leads disconnected at receiver. If compass coil is shorted, ^{Grounds and}
 it is most probable that it will be grounded. (NOTE.—All radio ^{short circuits in}
 compass circuits must be kept insulated from ground at all times.) ^{compass coil.}
 Test for ground with battery and telephones. (NOTE.—There will be a slight click, due to capacity of coil and leads.) Or test with battery and buzzer. If click in telephones is strong, but buzzer does not operate, look for dirt, moisture, or soldering flux on terminal ring, terminal block, collector rings, contactors, and points where wires enter shafting. If coil is not grounded, test for a direct short by exciting coil with battery and buzzer connected in series with coil, listening in on wavemeter. The fundamental of the SE 515A coil is about 400 meters, the SE 1512, tap 4, about 450 meters, and the SE 995 about 250 meters. If buzzer signals can not be obtained and tuned on wavemeter closely coupled, the compass coil will be found shorted.

31-989. Test A and B batteries for voltage and polarity with ^{Voltage and}
 voltmeter at receiver terminals. Polarity may also be tested with ^{polarity of bat-}
 a freshly cut potato; positive side turns potato green. ^{teries.}

31-990. Should the receiver fail to operate in "compass" ^{Operation of}
 position of the switch, the operation as a "receiver" should be ^{SE 1440 receiv-}
 tested by placing switch in "receiver" position. The coil leads ^{er and amplifier.}
 may be disconnected (this is not necessary), and if convenient, the receiver connected to an antenna, or the antenna and ground binding posts may be connected through a small inductance (four or five turns of wire) and coupled to a wavemeter. If the secondary controls of tuning, oscillations, and amplification are obtainable the inference is that the contacts of the switch are faulty on the "compass" side.

Open circuit
or short circuits,
SE 1440 receiver.

31-991. (1) Should the receiver fail to function in either condition, the continuity of the circuits should be tested. The use of battery and telephones is recommended in this test. The amplifying transformers may be tested by connecting the telephones across the secondary terminals, exciting the primary by flashing a low voltage battery across its terminals.

(2) Tests should also be made for the possible grounding to the copper shielding of the insulated circuits. The most prevalent defects of the receiver are the failure of contacts to close, particularly the contacts on the tube sockets; the connecting leads seldom become disconnected. The wiring of the detector and 3 stages of amplification may appear complicated at first glance. However, a little study will show that the function of the switch is merely to transfer the telephones to each succeeding tube, the filaments of the 4 tubes burning at all times.

(3) Howling in the amplifier is usually due to either an open grid connection or a disconnected transformer shunt condenser.

Operation of
the SE 1210 receiver.

31-992. The operation of this receiver may be tested as outlined in art. 31-990. However, when disconnecting the compass coil it is necessary to short the "secondary load" terminals. To remove any possibility of the trouble being in the amplifier, connect the telephones at the receiver, disconnecting the leads to the input terminals on the amplifier.

SE 1000 series and SE 1600 amplifier.

31-993. It is well first to insure operation of the receiver before investigating the amplifier. Test circuits with battery and telephones. NOTE: There is a characteristic difference in telephone click between a low-resistance circuit and a circuit containing a large inductance, i. e., testing transformers.

Operation of
SE 1762 compensating condenser.

31-994. (1) This is a small variable condenser (0.0003 μ f) and is connected between the compass coil lead extending to the grid side of the detector tube and the ground. Some compass stations require much more capacity for compensation than that contained in the SE 1762. This condenser was designed for and has sufficient capacity for the normal compass station. Should a particular compass station require more capacity for adequate compensation, this is an indication that the station is not well situated or that the condition of the antenna or communication lines is at fault. To test its operation (for open circuits) select some sharply tuned signal (wavemeter may be used), place this condenser either on zero or 180° mark; tune the compass coil to the signal very carefully with the tuning condenser of the receiver, then reverse the position of the compensating condenser. A large change in the capacity of the compensating condenser will alter the tuning of the compass coil and hence the signal intensity.

(2) Test for short circuit with battery and telephones or buzzer.

Direct-current
resistance of
compass coil.

31-995. The direct-current resistance of any compass coil, wound with No. 16 Navy standard bell wire, may be checked by measuring the length of the conductor and allowing 260 feet for one ohm.

Test of communication lines
for radio-frequency currents.

31-996. Communication lines and other lines entering the radio compass house, particularly when they are carried near the receiving circuits, are frequently a great source of trouble, causing

excessive amplitude in deviation and resulting in faulty operation of the radio compass. The trouble results from the presence of radio-frequency currents (signals) picked up by these wires and induced into the receiving circuits. To test for the presence of these signals, disconnect the coil leads from the SE 1440 receiver and ground them. Connect "loop" terminals of the receiver to the condenser terminals of a wavemeter. Connect another lead to the grid terminal and use this lead for exploring, touching it to the telegraph keys, relays, telephone lines, etc. The receiver should preferably be in a regenerative condition with full amplification and tuned by means of the wavemeter either to 600 or 800 meters. If signals are heard in this way, the lines must be drained with condensers, shielded or removed entirely from the proximity of the receiving apparatus.

31-997. (1) Installation defects usually consist of excessive capacity to ground or direct grounding of radio compass circuits. Installation defects.
In ship installations the most flagrant cases are:

Battery leads in lead-covered wire.

Batteries placed too close to metal bulkhead or deck.

Coil leads or connecting leads too close to metal bulkhead.

SE 1440 receiver too close to metal bulkhead.

Mast stays in vicinity of compass coil form closed loop.

Antenna lead in.

(2) In shore installations the usual defects are the presence of lead and armored cable or any grounded conductors in close proximity to:

The receiver, especially when the SE 1440 is used.

The batteries.

The telephone cords.

(3) The remedies are obvious. In general, a minimum distance of 3 inches should be allowed between any of the circuits or apparatus and ground, the ground leads to the compensator and to the ground terminal on the SE 1440 receiver (SE 1512 compass installation) being the exceptions; these leads, where they run parallel to the receiver, should be properly spaced. The importance of breaking up any closed loops of large dimensions near the compass coil must not be overlooked, as such loops have been known to cause deviations as high as 45°. The best method is to insert a strain insulator at the top of each of the stays, grounding these stays at the deck. Any change of this kind should be done previous to the calibration.

(4) The antenna lead in (after radio-room destroyers) should be brought into a grounded trunk where it passes the compass coil housing, and the rat-tail should be securely held in a definite location.

31-998. (1) In shore radio compass stations a certain amplitude of deviation is normal to the station, depending on the characteristics of the site. Thus it has been found that a compass station situated very close to the surf on a flat sandy beach will exhibit a deviation amplitude (maximum) of about three-fourths of a degree, increasing to about 2° for a station located 300 yards inland and 25 feet above sea level. At compass stations such Excessive deviation and compensation.

as these the compensation values throughout the azimuth will vary from 100 to 200 $\mu\mu\text{f}$. Should a compass station in a similar location exhibit a deviation curve whose amplitude greatly exceeds these values, the condition of all antennas and near-by metallic circuits, should be investigated for the purpose of reducing this deviation to normal.

High rocky ground.

(2) In cases where compass stations are situated on or near high rocky ground, it is impossible to estimate the deviation that will be normal. Such locations should be avoided as much as possible, and if circumstances necessitate a compass station in such a locality, the site should first be tested by a trial calibration. In general, it has been found that the operation of compass stations exhibiting a deviation curve of low amplitude is more consistently accurate.

(3) In the case of radio compass installations on board ships the same general conditions apply, although not so closely, as the factors which determine the amplitude of deviation are more constant.

Influence of local metal bodies.

(4) Neglecting the effect of local metal bodies on shipboard, it has been found that deviation is nearly proportional to the length and height of the vessel. When extraneous effects are removed, the average for destroyers should not exceed 5°. For battleships and larger vessels it will be from 20° to 25°. It has been very evident from work on destroyer compasses that any metal body in the vicinity of the coil house which forms a closed electrical loop will cause excessive deviation. Brass rails or wire rope, awning supports, and particularly mainmast stays forming loops will cause deviations as high as 45° on destroyers. When these influences are removed, it is found that the calibration curve passes through zero deviation very close to 0°, 90°, 270°, and 360°, which is normal.

(5) While battleships generally show a maximum of 20° to 25° and are approximately 600 feet in length, one vessel, 700 feet in length (the *Mount Vernon*) has a maximum of 15°. The latter installation was located much higher than is ordinarily the case.

INDEX.

A.

	Article.
"A" battery.....	31-859 to 31-860
A and B group, radio compass equipment.....	31-916 to 31-918
Absorbing circuit capacity, 20-kilowatt arc transmitter.....	31-272
inductance, 20-kilowatt arc transmitter.....	31-271
resistance, 20-kilowatt arc transmitter.....	31-270
wave length of, 20-kilowatt arc transmitter.....	31-294
Acceptor-rejector equipment, model E.....	31-634 to 31-635, 31-654, 31-656 to 31-658
model F.....	31-634 to 31-635, 31-654, 31-656 to 31-658
model R.....	31-634, 31-653 to 31-655, 31-657 to 31-658
circuit.....	31-625 to 31-663
Accessories, 500-cycle, quenched spark transmitter.....	31-136
Accountability of officer in charge of communication station.....	31-43
Accuracy of the radio compass.....	31-904
Activities afloat, communication facilities.....	31-21
communication facilities.....	31-6
in connection with other Bureaus.....	31-15
with aircraft shore units.....	31-18
with ships.....	31-16
with shore units.....	31-17
shore, communication facilities.....	31-29
with aircraft at sea, communication facilities.....	31-19
Adjusting carbon, 20-kilowatt arc transmitter.....	31-285
inductance, 20-kilowatt arc transmitter.....	31-267
mechanism of arc, 20-kilowatt arc transmitter.....	31-265
wave length, 20-kilowatt arc transmitter.....	31-282
Adjustments and tuning, high power, quenched spark transmitter.....	31-132
Adjustment, final, receivers.....	31-489
fine, receivers.....	31-459
for maximum output, vacuum tube transmitters.....	31-331
power, 500-cycle quenched spark transmitter.....	31-133
of acceptor-rejector in model R booth.....	31-655
alternating current supply circuit, auxiliary spark transmitter.....	31-179
auxiliary spark transmitter break key, send-receive.....	31-177
back coupler, receivers.....	31-476
vacuum tube detector.....	31-563
break key, auxiliary spark transmitter.....	31-177
coupling, receivers.....	31-479
crystal detector.....	31-485
filament current, receivers.....	31-473
vacuum tubes, receiving.....	31-812
gap, rotary.....	31-146
main-line contactors, 20-kilowatt arc transmitter.....	31-290
transmitting key, 20-kilowatt arc transmitter.....	31-269
Administration of Naval Communication Service.....	31-3, 31-8
Advantages of arc transmitter.....	31-253
radio-frequency driver or heterodyne.....	31-577
radio-frequency amplification.....	31-533
Aids to selectivity, model RB receiving equipment.....	31-677
Aircraft antennas, directional effect.....	31-417
at sea, communication facilities, activities with.....	31-19
drills, emergency kite antenna.....	31-435
emergency communication.....	31-431 to 31-435
interphones.....	31-427 to 31-430
maximum method, radio compass.....	31-909
radio compass.....	31-424 to 31-426
coil.....	31-423

	Article.
Aircraft radio equipment.....	31-400 to 31-435
tests of, preparatory to flight	31-416
installation F-5-L.....	31-412
receiving equipment	31-418 to 31-430
transmitters.....	31-407 to 31-417
receiving equipment	31-418 to 31-430
shore units, communication facilities with.....	31-18
transmission, continuous-wave.....	31-417
transmitter, Chaffee gap	31-409 to 31-412
quenched spark	31-409
vacuum tube.....	31-413 to 31-417
Allowance of furniture, communication stations.....	31-65
Alterations and repairs to acceptor-rejector circuits	31-662
Alternating current supply circuit, auxiliary spark transmitter	31-179
Alternator, field sets.....	31-883
Ammeter, antenna, panel, motor, buzzer	31-213
quenched spark transmitter.....	31-125
20-kilowatt arc transmitter.....	31-269
filament, vacuum tube detector.....	31-553
Amount of amplification, radio-audio-frequency.....	31-532
Amplification, audio-frequency	31-594
model TC vacuum tube transmitter	31-355 to 31-357
radio compass, ships.....	31-927
Amplifier, audio-frequency, acceptor-rejector circuits	31-650
and radio-audio-frequency.....	31-525 to 31-538
vacuum tubes used in.....	31-811 to 31-815
connections, receiver	31-493
radio-audio-frequency, model RB receiving equipment.....	31-690
vacuum tubes used in	31-811 to 31-815
radio compass, defects in.....	31-986
SE 1600, operation of.....	31-530
series, SE 1000, operation of.....	31-530
3-stage audio-frequency.....	31-528
Amplifiers, aircraft receivers.....	31-421
Amplitude of oscillating current, arc transmitter.....	31-258
Annual report of shore communication stations.....	31-71
communication activities, commanders in chief.....	31-70
on communication installations, commanding officers.....	31-72, 31-74
on communication installations, district craft	31-73
Anode tip, lining up, 20-kilowatt arc transmitter	31-284
to replace, 20-kilowatt arc transmitter	31-284
Anode, 20-kilowatt arc transmitter	31-266
Antenna, aircraft, directional effect	31-417
ammeter panel, motor-buzzer, transmitter	31-213
quenched spark transmitter	31-125
20-kilowatt arc transmitter.....	31-269
auxiliary, location of.....	31-196
circuit, receivers.....	31-457, 31-484
500-cycle quenched spark transmitter.....	31-107
condenser dial method of tuning receivers.....	31-483
current, spark transmitters.....	31-155
effect, radio compass.....	31-911 to 31-912
field sets.....	31-880
ground, vacuum tube transmitter.....	31-333
kite, emergency.....	31-433, 31-434
leak coil, acceptor-rejector circuit	31-645
lead, radio compass, ships.....	31-927 to 31-928
loading coil, acceptor-rejector circuits.....	31-637
inductance.....	31-121, 31-136, 31-147
inductance, 20-kilowatt arc transmitter.....	31-267
model RB receiving equipment	31-683
oscillations.....	31-101, 31-107
radio compass.....	31-906, 31-927, 31-928

	Article.
Antenna, small receiving.....	31-525
transfer switch, 20-kilowatt arc transmitter.....	31-283
tuning condenser, acceptor-rejector circuit.....	31-647
inductance, SE 3524.....	31-636
SE 3348.....	31-646
receivers.....	31-A.3
Apparatus, radio compass, tests of.....	31-987 to 31-998
Application of tuned telephone.....	31-726
radio compass, practical.....	31-908
Appropriation for wire lines, communication stations.....	31-47
Arc adjusting mechanism, 20-kilowatt arc transmitter.....	31-265
breaking, 20-kilowatt arc transmitter.....	31-277
chamber, 20-kilowatt arc transmitter.....	31-266, 31-288
circuit, simple.....	31-256
converter, 20-kilowatt arc transmitter.....	31-266
striking, 20-kilowatt arc transmitter.....	31-266
transmitter.....	31-250 to 31-297
circuit.....	31-262
operation, peculiarities of.....	31-293
20-kilowatt transmitter.....	31-264 to 31-297
Arrangement of instruments, radio compass, ships.....	31-928
Assembly, motor buzzer transmitter.....	31-210
Assignment of radio material officers.....	31-10
Audibility measurements.....	31-490
Audio-frequency amplification.....	31-564
amplifier.....	31-527 to 31-531
acceptor-rejector circuits.....	31-650
3-stage.....	31-528
Authority at isolated radio stations.....	31-9
for expenditures, communication stations.....	31-60
Autodyne reception, vacuum tube detectors.....	31-532
Auxiliary antenna, location of.....	31-186
spark transmitters.....	31-150 to 31-186

B.

'B' battery.....	31-858
B group, radio compass equipment.....	31-916, 31-918
Back coupler adjustment, receivers.....	31-476
vacuum tube detector.....	31-563
Balance of inductance, auxiliary spark transmitter.....	31-172
Balancing, motor buzzer transmitter.....	31-217
unit, constants of, model TB radio telephone transmitter.....	31-342
Ballast lamp, heterodyne.....	31-587
lamps, vacuum tubes.....	31-815
Barrage effect, failure of, model RB receiving equipment.....	31-664
tuning unit, model RB receiving equipment.....	31-685
Batteries, polarity and voltage of, radio compass.....	31-989
power, radio compass.....	31-924
storage.....	31-861 to 31-864
radio equipment.....	31-850 to 31-864
receiver, radio compass.....	31-925
vacuum-tube radio transmitter, grounding.....	31-333
Battery leads, radio compass, ships.....	31-952
Battleship equipment, acceptor-rejector circuits.....	31-654
Bearings by radio compass.....	31-981 to 31-983
radio compass, correction sheets, for ships.....	31-967
Bids and contracts, communication stations.....	31-61
Blower, auxiliary spark transmitter.....	31-173
Booth entering fitting, acceptor-rejector circuits.....	31-642
Break key, adjustment of, auxiliary spark transmitter.....	31-177
auxiliary spark transmitter.....	31-171

	Article.
Bridging condenser, grid and, condensers vacuum-tube detectors.....	31-555
receivers.....	31-468
Bright spots on filament, model TB radio telephone transmitter.....	31-347
Brush holders, motor-buzzer transmitter.....	31-210
Budget, Coast signal service.....	31-22
Buildings, shore radio compass stations.....	31-933,
	31-905 to 31-937
Bulkheads, radio compass, ship.....	31-952
Bureau of Engineering, Radio Division.....	31-8
responsibility, shore communication stations.....	31-28
Buzzer assembly.....	31-210
coupling coil, acceptor-rejector circuits.....	31-642
motor, relay.....	31-210
transmitters.....	31-200 to 31-228
signal method of tuning receivers.....	31-483
test, receivers.....	31-470
wheel.....	31-205, 31-210,
	31-223, 31-225
C.	
C group, radio compass equipment.....	31-915, 31-918
Cables, shore radio compass stations.....	31-940
Calibration curve, radio compass, ships.....	31-966 to 31-967
data form, radio compass, ships.....	31-959
for wave length, radio compass, ships.....	31-927
shore radio compass stations.....	31-941
of antenna circuit, receivers.....	31-484
radio compass, report on.....	31-83, 31-84
ships.....	31-949 to 31-967
receiver, shore radio compass stations.....	31-969
report of, shore radio compass.....	31-980
shore radio compass stations.....	31-968 to 31-980
Calibrating party, shore radio compass stations.....	31-972 to 31-973
vessel, instructions to, radio compass, ships.....	31-941
shore radio compass stations.....	31-975
Capacity, absorbing circuit, 20-kilowatt arc transmitter.....	31-272
curve of condensers.....	31-818
heterodyne.....	31-583
Carbon, adjusting, 20-kilowatt arc transmitter.....	31-285
holder, 20-kilowatt arc transmitter.....	31-295
replacing, 20 kilowatt arc transmitter.....	31-286
Care and operation, instruction and data, communication facilities.....	31-4
upkeep of acceptor-rejector circuits.....	31-658 to 31-663
arc transmitters.....	31-297
auxiliary spark transmitters.....	31-185 to 31-186
interphones, aircraft.....	31-429
motor-buzzer transmitters.....	31-223 to 31-228
quenched spark transmitter.....	31-138 to 31-149
receivers.....	31-494 to 31-500
in handling wavemeters.....	31-767
of batteries, S-1 3535A, dry.....	31-855 to 31-857
counterpoise, field sets.....	31-895
field sets.....	31-896
power storage batteries, radio equipment.....	31-864
radio compass.....	31-984 to 31-985
silver-plated surfaces, acceptor-rejector circuits.....	31-658
telephones.....	31-805
• Casualty to communication installation, report on.....	31-82
Cathode, 20-kilowatt arc transmitter.....	31-266
Causes of defects, radio compass, ships.....	31-952, 31-953
Cause of reduction in signal strength, acceptor-rejector.....	31-631
Chaffie gap, transmitter, aircraft.....	31-109 to 31-111
Chamber, arc, 20-kilowatt arc transmitter.....	31-266, 31-285

	Article.
Changes in communication installations, report on.....	31-72, 31-81
wavemeter, making.....	31-763
Changing wave length, 20-kilowatt arc transmitter.....	31-281
Characteristics, motor buzzer.....	31-201
Charging panels, radio compass.....	31-923
units.....	31-860
Chest, transmitter and receiver, field sets.....	31-887
Circuit, antenna, receivers.....	31-457,
	31-481 to 31-484
500-cycle quenched spark transmitter.....	31-197
arc transmitter, practical.....	31-292
simple.....	31-255
breaker, 500-cycle quenched spark transmitter.....	31-141
capacity, absorbing, 20-kilowatt arc transmitter.....	31-272
formed by ship's rigging, radio compass.....	31-952
inductance, absorbing, 20-kilowatt arc transmitter.....	31-271
intermediate, model RB receiving equipment.....	31-673
loop, model RB receiving equipment.....	31-686
motor buzzer.....	31-209
model TB radio telephone equipment.....	31-313
parallel oscillatory, theory, acceptor-rejector circuits.....	31-629
primary, auxiliary spark transmitter.....	31-133, 31-135
resistance, absorbing, 20-kilowatt arc transmitter.....	31-270
secondary, fine adjustment of, receivers.....	31-459
model RB receiving equipment.....	31-680
series oscillatory, theory, acceptor-rejector circuits.....	31-628
tuned telephone.....	31-723
typical oscillating vacuum tube.....	31-328
wavemeter, essential.....	31-751
500-cycle, quenched spark transmitter.....	31-105
Circuits, acceptor-rejector.....	31-625 to 31-667
coupled, vacuum tube transmitters.....	31-532
low resistance, necessity for, radio compass.....	31-913
model TC vacuum tube transmitter.....	31-355
modulator and amplifier.....	31-356, 31-357
open, radio compass.....	31-988
radio compass, tests of.....	31-987 to 31-998
series and parallel oscillatory, combination of, acceptor-rejector.....	31-630
short, radio compass.....	31-988
Clamping bars, auxiliary spark transmitter.....	31-169
Classes of amplifiers.....	31-525
spark transmitters.....	31-100
Cleaning receivers.....	31-101
Clearance, rotary spark gap, 500-cycle quenched spark transmitter.....	31-115
Closed circuit, 500-cycle quenched spark transmitter.....	31-106
Cooling, water, 20-kilowatt arc transmitter.....	31-265, 31-287
Coast Signal Service.....	31-1
budget.....	31-22
Coil, antenna leak, acceptor-rejector circuits.....	31-615
loading, acceptor-rejector circuits.....	31-637
buzzer coupling, acceptor-rejector circuits.....	31-642
heterodyne.....	31-585
receivers model RB receiving equipment.....	31-687
coupling, aircraft radio.....	31-461
shield.....	31-462
loading, auxiliary spark transmitter.....	31-167
primary, transformer, 500-cycle quenched spark transmitter.....	31-114
radio compass, aircraft.....	31-423
defects in.....	31-985
direct-current resistance of.....	31-935
Coil, reactance, 500-cycle quenched spark transmitter.....	31-114
Coils, series field, 20-kilowatt arc transmitter.....	31-295

	Article.
Collector system, model RB receiving equipment.....	31-678
Collectors, small, signal amplification.....	31-525
Combination of series and parallel oscillatory circuits, acceptor-rejector.....	31-630
Combinations, power, field sets.....	31-883
Commanders in chief, annual report on communication activities.....	31-70
Commanding officers, Air Forces, monthly report on communication installations.....	31-89
report on communication installations.....	31-72, 31-74
Common faults, receivers.....	31-497
Communication activities.....	31-5
reports on.....	31-69 to 31-85
emergency, aircraft.....	31-431 to 31-435
equipment, inspection of.....	31-4
installation of.....	31-4
manufacture of.....	31-4
testing of.....	31-4
facilities, activities afloat.....	31-21
ashore.....	31-20
in connection with other bureaus.....	31-15
with aircraft at sea.....	31-19
shore units.....	31-18
design.....	31-4
development work.....	31-4
experiments.....	31-20
general public.....	31-7
Government activities.....	31-7
life and property, preservation of.....	31-7
maintenance.....	31-1
patents.....	31-4
preservation of life and property.....	31-7
program of expenditures.....	31-23
provisions for operation.....	31-12
public works projects.....	31-24
repairs.....	31-25
and alterations.....	31-4
requisitions.....	31-4
research.....	31-4
scope of yards.....	31-10
technical data on.....	31-4
instructions about.....	31-4
tests.....	31-20
field sets of Marine Corps.....	31-35
installation, casualty to.....	31-82
installations, district craft, report on.....	31-73
forms for reports on.....	31-85
monthly report on.....	31-79, 31-89
quarterly report on.....	31-75 to 31-78
report on changes in.....	31-72, 31-81
instruments, shore radio compass stations.....	31-945, 31-970
lines, radio compass shore stations.....	31-920
test of, radio compass.....	31-995
requirements of fleets.....	31-7
service, naval, administration of.....	31-3
station, accountability of officer in charge of.....	31-43
officer, duties on being relieved.....	31-45
report by, on taking charge.....	31-44
stations, allowance of furniture.....	31-65
appropriation for wire lines of.....	31-47
bids and contracts.....	31-61
efficient operation.....	31-56
efficiency of plant.....	31-53
expenditures.....	31-60
furniture.....	31-65

	Article.
Communication stations, inspection of.....	31-48
inventory.....	31-42
isolated.....	31-9
outside naval districts.....	31-33
yard but within naval district.....	31-32
part of Marine Corps detachment.....	31-34
quarters.....	31-64
request for repairs.....	31-59
requests and requisitions.....	31-53
responsibility of officer in charge of.....	31-41
scope of material inspection.....	31-51
shore, Bureau of Engineering, responsibility at.....	31-28
list of.....	31-62
minor repairs.....	31-33
repairs by personnel of.....	31-37
reports of inspection of.....	31-49, 31-54
transfer of officers in charge of.....	31-46
within maintenance yards.....	31-30
within naval air stations.....	31-31
superintendents, expenses of.....	31-39
tube, ship radio compass stations.....	31-921
units, establishment of.....	31-4
with bridge, radio compass.....	31-927
calibrating vessel, radio compass, ship.....	31-965
Comparison between model RB and other receiving equipment.....	31-676
Compass coil, aircraft, radio.....	31-423
radio, aircraft.....	31-424 to 31-426
equipment.....	31-900 to 31-993
Compensating antenna effect, adjustment for.....	31-912
condenser, SE 1762 radio compass, operation of.....	31-994
shore radio compass stations.....	31-944
variation curve, shore radio compass stations.....	31-979
Compensation, excessive, radio compass.....	31-993
wave, arc transmitters.....	31-259
Condenser, antenna tuning, acceptor-rejector circuits.....	31-647
as, arc transmitter, current transforming circuit.....	31-261
auxiliary spark transmitter.....	31-155
bridging, receivers.....	31-468
compensating SE 1762 radio compass, operation of.....	31-994
shore radio compass stations.....	31-944
coupling board, auxiliary spark transmitter.....	31-170
defective wavemeter.....	31-772
500-cycle quenched spark transmitter.....	31-118, 31-136
grid and bridging, vacuum tube detector.....	31-555
grid, and leak.....	31-469
rack, 500-cycle quenched spark transmitter.....	31-136
rejector, acceptor-rejector circuits.....	31-640
setting, radio telephone, aircraft.....	31-475
tuned telephone.....	31-730
transmitting, auxiliary spark transmitter.....	31-135
wavemeter.....	31-760
Condensers.....	31-816 to 31-829
Conditions for oscillation, vacuum-tube transmitter.....	31-330
Connections, arc transmitter.....	31-294
heterodyne.....	31-599
Connections, model RB receiving equipment.....	31-691
radio-audio-frequency amplifier.....	31-537
transmitter and receiver chest, field sets.....	31-887
Constants of balancer unit, model TB telephone transmitter.....	31-542
Construction of buildings, shore radio compass stations.....	31-937
Contact relay, double, 20-kilowatt arc transmitter.....	31-273
Contactors, main-line, adjustment of, 20-kilowatt arc transmitter.....	31-230

	Article.
Continuous-wave, telegraph transmission, model TC radio equipment.....	31-353
transmission, aircraft	31-417
transmission, arc transmitter.....	31-251
vacuum-tube transmitter	31-323
Contour of coast line, shore radio compass stations.....	31-931 to 31-952
Contracts and bids, communication stations.....	31-61
Control, hydrocarbon, 20-kilowatt arc transmitter.....	31-265
of filament current, vacuum tubes, receiving.....	31-814
switchboard, 20-kilowatt arc transmitter.....	31-265
Controller drum, 20-kilowatt arc transmitter.....	31-265
Controls, radio-audio-frequency amplifier.....	31-533
Converter, arc, 20-kilowatt arc transmitter.....	31-266
Cooperation between public works and radio material officer.....	31-26
with other bureaus, communication facilities.....	31-15
Copper strips, auxiliary spark transmitter.....	31-172
Correction sheets for radio compass bearings, ships.....	31-967
Correspondence, communication facilities.....	31-11
Counterpoise, field sets.....	31-881, 31-895
magnetic, 20-kilowatt arc transmitter.....	31-266
Coupled circuits, vacuum-tube transmitter.....	31-332
Coupler, back, receivers.....	31-168
auxiliary spark transmitter.....	31-481
inductive, 500-cycle quenched spark transmitter.....	31-119, 31-136, 31-147
Coupling, adjustment of, receivers.....	31-479
and decrement, motor buzzer transmitter.....	31-217
auxiliary spark transmitter.....	31-154
board, auxiliary spark transmitter.....	31-168
condensers, auxiliary spark transmitter.....	31-170
click method of tuning, receivers.....	31-483
coil, receivers.....	31-461
buzzer, acceptor-rejector circuit.....	31-642
heterodyne.....	31-585
model RB receiving equipment.....	31-687
shield, receivers.....	31-462
loose, receivers.....	31-479
model TB radio telephone transmitter.....	31-541
optimum, receivers.....	31-479
Cranking engine, field sets.....	31-889
Crystal-audion switch, receivers.....	31-466
Crystal detector, adjustment of.....	31-485
detectors.....	31-806 to 31-819
Current, antenna, auxiliary spark transmitter.....	31-155
filament, adjustment of, receivers.....	31-473
model TB radio telephone transmitter.....	31-344, 31-345
vacuum-tube detector.....	31-566
receiving.....	31-812, 31-814
in absorbing circuit, arc transmitter.....	31-294
plate, model TB radio telephone transmitter.....	31-345
radio-frequency, test for, in radio compass communication lines.....	31-966
transforming circuit, arc transmitter.....	31-266
Curve, calibration, radio compass, ships.....	31-966 to 31-967
compensating condenser variation, shore radio compass stations.....	31-979

D.

D group, radio compass equipment.....	31-917 to 31-918
Data form, radio compass calibration, ships.....	31-959
performance, shore radio compass stations.....	31-917
plotting of calibration of shore radio compass station.....	31-978
technical, communication facilities.....	31-4
Decrement and coupling, motor buzzer, transmitter.....	31-217
radiation, 500-cycle, quenched spark transmitter.....	31-107

	Article.
Decimeter.....	31-754
effective, arc transmitter.....	31-252
Defective telephones, receivers.....	31-500
transformers, audio-frequency.....	31-531
quenched gap, 500-cycle quenched spark transmitter.....	31-145
unit, acceptor-rejector circuits.....	31-660
Defects, causes of, radio compass, ships.....	31-952 to 31-953
in amplifier, radio compass.....	31-986
radio compass coil.....	31-985
receiver, radio compass.....	31-985
of installation, radio compass.....	31-967
minima, radio compass.....	31-984
3-47	31-347
Deformation of filament or grid, model TB radio telephone transmitter.....	31-538
Degree of amplification, receiving.....	31-634 to 31-650
Description of acceptor-rejector circuits.....	31-264 to 31-273
arc transmitters.....	31-529
audio-frequency amplifiers.....	31-160 to 21-175
auxiliary spark transmitters.....	31-851
batteries, SE3535A.....	31-410
Chaffee gap transmitter, aircraft.....	31-878 to 31-883
field sets.....	31-112 to 31-125
500-cycle quenched spark transmitter.....	31-682 to 31-691
model RB receiving equipment.....	31-340 to 31-343
model TB radio telephone transmitter.....	31-359 to 31-362
model TC vacuum tube transmitter.....	31-205 to 31-215
motor-buzzer transmitter.....	31-881
power storage batteries, radio equipment.....	31-536
radio-audio-frequency amplifier.....	31-914 to 31-926
radio compass.....	31-451 to 31-470
receivers.....	31-467
synchronous spark transmitters, aircraft.....	31-728 to 31-732
tuned telephone.....	31-529
2-step audio-frequency amplifier.....	31-802
types of telephones.....	31-552 to 31-559
vacuum-tube detectors.....	31-4
Design, communication facilities.....	31-653
Destroyer installations, acceptor-rejector circuits.....	31-927 to 31-928
radio compass.....	31-951, 31-955 to 31-967
Details, calibration of radio compass, ships.....	31-481
Detector, receivers.....	31-806 to 31-810
Detectors, crystal.....	31-550 to 31-565
vacuum-tube.....	31-425 to 31-426
Determining direction, aircraft radio compass.....	31-4
Development work, communication facilities.....	31-998
Deviation, excessive, radio compass.....	31-762
Device, indicating, wavemeter.....	31-163
Devices, protective, auxiliary spark transmitter.....	31-752
resonance, indicating, wavemeter.....	31-124
500-cycle quenched spark transmitter.....	31-327 to 31-354
Dial, setting, calibration of radio compass, ships.....	31-671
shot radio compass stations.....	31-965
Diaphragms, telephones.....	31-985
Direct-current resistance of radio compass coil.....	31-264
supply, motor-buzzer.....	31-425 to 31-426
Direction, determining of, aircraft, radio compass.....	31-967
Directional characteristic, radio compass.....	31-417
effect, aircraft antenna.....	31-578
Disadvantages of radio-frequency driver or heterodyne.....	31-949
Distortion of wave, radio compass, ships.....	31-39
District communication superintendents, expenses of.....	31-75
craft, annual report on communication installations.....	31-8
Division, Radio, Bureau of Engineering.....	

	Article.
Double contact relay, 20-kilowatt arc transmitter.....	31-273
reception, acceptor-rejector circuits.....	31-633, 31-656 to 31-657
Drills, emergency kite antenna, aircraft.....	31-435
Driver, radio-frequency, model RB, receiving equipment.....	31-689
Drivers, radio-frequency or heterodyne.....	31-575 to 31-591
Drum controller, 20-kilowatt arc transmitter.....	31-265
Duplex feature, model TB radio telephone equipment.....	31-340
Duties of communication station officer on being relieved.....	31-45
Duties of radio material officer.....	31-14
E.	
E, model, acceptor-rejector circuits.....	31-634 to 31-635, 31-654, 31-656 to 31-658
Edison "A" battery, radio equipment.....	31-859
Edison "B" battery, radio equipment.....	31-858
Effect, directional, aircraft antenna.....	31-417
Effective decrement, arc transmitter.....	31-252
Efficiency, aircraft radio transmitters.....	31-403
of operation, communication stations.....	31-56
plant of communication station.....	31-53
vacuum-tube transmitter.....	31-334
Electrical action of acceptor-rejector circuit.....	31-631
Electrolysis of glass, model TB radio telephone equipment.....	31-347
Electromagnetic shielding, radio compass, ships.....	31-928
shore radio compass stations.....	31-938
Electromotive force in loop, radio compass.....	31-907
Elimination of interference, auxiliary spark transmitter.....	31-151
Emergency kite antenna, aircraft.....	31-431 to 31-435
power supply, radio transmitters.....	31-859
Engine, field set.....	31-883, 31-888 to 31-889, 31-892
Equipment, acceptor-rejector, types of.....	31-634
aircraft, radio receiving.....	31-418 to 31-430
of calibrating party, shore radio compass stations.....	31-973
field sets.....	31-876
radio, aircraft.....	31-400 to 31-435
radio compass.....	31-900 to 31-938
model TC transmitter.....	31-349 to 31-369
receiving, large planes.....	31-422
telephone, model TB.....	31-339 to 31-348
record of, shore radio compass stations.....	31-946
Establishing radio communication with extension station, model TC transmitter.....	31-364
Establishment of communication units.....	31-4
Example of calibration of radio compass, ships.....	31-964
Excessive compensation, radio compass.....	31-998
deviation, radio compass.....	31-998
Exhaust gases, field sets.....	31-894
Expenditures, communication stations.....	21-60
program of, communication facilities.....	31-23
Expenses of communication superintendents.....	21-39
Experiments, communication facilities.....	21-20
Extension station, establishing radio communication with, model TC transmitter.....	31-364
F.	
F, model, acceptor-rejector equipment.....	31-634 to 31-635, 31-654, 31-656 to 31-658
Fading, model RB receiving equipment.....	31-696
Failure of barrage effect, model RB receiving equipment.....	31-694
oscillation, receivers.....	31-478
vacuum tube, model TB radio telephone equipment.....	31-547
to amplify, audio-frequency amplifiers.....	31-531
oscillate, vacuum-tube detectors.....	31-555
receive, receivers.....	31-436
radio-audio-frequency amplifiers.....	31-538
suppress interference, tuned telephone.....	31-735
static, tuned telephone.....	31-737

	Article.
Faults and remedies, acceptor-rejector circuits.....	31-658 to 31-663
aircraft radio equipment.....	31-417
arc, transmitter.....	31-295 to 31-296
audio-frequency amplifiers.....	31-531
batteries for radio equipment.....	31-855
condensers.....	31-819 to 31-820
crystal detectors.....	31-810
field sets.....	31-890 to 31-896
heterodyne.....	31-593
model RB receiving equipment.....	31-694 to 31-698
TB radio telephone transmitter.....	31-348
TC vacuum tube transmitter.....	31-365 to 31-369
power storage batteries.....	31-864
radio-audio-frequency amplifiers.....	31-538
radio compass.....	31-984 to 31-986
receivers.....	31-497 to 31-500
telephones.....	31-805
tuned telephone.....	31-735 to 31-737
vacuum tube detector.....	31-565 to 31-566
receiving.....	31-813
wavemeters.....	31-767 to 31-772
F-5-L, radio installation.....	31-412
Field coils, series, 20-kilowatt arc transmitter.....	31-266
Field sets, communication, of Marine Corps.....	31-35
equipment.....	31-875 to 31-896
Field strength, 20-kilowatt arc transmitter.....	31-292
Filament ammeter, vacuum-tube detector.....	31-553
and plate supply, heterodyne.....	31-591
current, adjustment of, receivers.....	31-473
model TB radio telephone equipment.....	31-344, 31-345
vacuum-tube detector.....	31-556
vacuum-tubes, receiving.....	31-812, 31-814
rheostat, vacuum-tube detector.....	31-554
Filter system, vacuum-tube detector.....	31-558
Final adjustment, receivers.....	31-489
Fine adjustment, receivers.....	31-459
First stage of amplification, audio frequency.....	31-527
Fish paper gaskets, 500-cycle quenched spark transmitter.....	31-145
Five hundred cycle, circuit.....	31-105
quenched spark transmitter.....	31-103 to 31-149
Five-kilowatt 500-cycle quenched spark transmitter, type CR 1125.....	31-112 to 31-149
Fleets, communication requirements of.....	31-77
Flight, tests preparatory to, aircraft radio equipment.....	31-416
Floor covering, communication stations.....	31-66
Forms for reports on communication installations.....	31-85
Form, radio compass calibration data, ship.....	31-959
Frequency, group, 500-cycle quenched spark transmitter.....	31-102
resonant, of 500-cycle circuit.....	31-130
spark, motor buzzer transmitter.....	31-207
Function of Radio Material Officer.....	31-13
Functioning of Naval Communication Service.....	31-3
Furniture, communication stations.....	31-35

G.

Gap, Chaffee, transmitter, aircraft.....	31-410
motor buzzer.....	31-205
quenched, sparking surface.....	31-145
rotary, adjustment.....	31-146
Gaskets, quenched spark gap.....	31-145
General information, shore radio compass stations.....	31-948
instructions, 20-kilowatt arc transmitter.....	31-274

	Article.
General precautions, are transmitter.....	31-297
auxiliary spark transmitter.....	31-185
500-cycle quenched spark transmitter.....	31-149
model TC vacuum tube transmitter.....	31-309
public, communication facilities.....	31-7
Generator, failure of, field set.....	31-891
motor, 500-cycle quenched spark transmitter.....	31-113, 31-136, 31-139
Generators and batteries, position of, vacuum tube transmitters.....	31-333
Government activities, communication facilities.....	31-7
Grid and bridging condensers, vacuum-tube detector.....	31-555
condenser and leak.....	31-469
leak, heterodyne.....	31-588
vacuum-tube detector.....	31-556
Ground system, shore radio compass stations.....	31-630
Grounding shields of model RB receiving equipment.....	31-698
Grounds, radio compass.....	31-608
Group C, radio compass equipment.....	31-915, 31-918
D, radio compass equipment.....	31-917, 31-918
frequency, 500-cycle quenched spark transmitter.....	31-101
of shore radio compass stations.....	31-930
Groups A and B, radio compass equipment.....	31-916, 31-918

II.

Height above decks of radio compass.....	31-928
Helmets.....	31-430
Heterodyne capacity.....	31-583
or radio-frequency driver.....	31-575 to 31-594
High power adjustment and tuning, 500-cycle quenched spark transmitter.....	31-132
resistance, receivers.....	31-199
rocky ground, effect of, at shore radio compass stations.....	31-608
Hissing, model RB receiving equipment.....	31-697
Holder, carbon, 20-kilowatt are transmitter.....	31-266
Howling, audio-frequency amplifiers.....	31-531
model RB receiving equipment.....	31-695
Hydrocarbon control, 20-kilowatt are transmitter.....	31-265
supply of, 20-kilowatt are transmitter.....	31-261

I.

Impedance, motor buzzer transmitter.....	31-211
Indicating devices, resonance wavemeters.....	31-752, 31-762
Indication of radiation, motor-buzzer transmitter.....	31-220
resonance, wavemeters.....	31-753
Inductance, absorbing circuit, 20-kilowatt are transmitter.....	31-271
adjusting, 20-kilowatt are transmitter.....	31-267
antenna, loading, 500-cycle quenched spark transmitter.....	31-121, 31-136,
50-kilowatt are transmitter.....	31-267
tuning, acceptor-rejector circuits.....	31-636
auxiliary spark transmitter.....	31-173
balance of, auxiliary spark transmitter.....	31-172
heterodyne.....	31-584
motor buzzer.....	31-208, 31-228
rejector, acceptor-rejector circuits.....	31-641
switch, receivers.....	31-465
tuned telephone.....	31-731
wavemeters.....	31-761
20-kilowatt are radio transmitter.....	31-267
Inductive back coupling, coupler, 500-cycle quenched spark transmitter.....	31-119, 31-136, 31-147
receivers.....	31-451
Information, general, shore radio compass stations.....	31-918
on acceptor-rejector circuits.....	31-663

	Article.
Inspection of communication equipment	31-4
station by representative of the Department	31-57
stations	31-48
emergency kite antenna, aircraft	31-485
field sets	31-896
material, of communication stations, scope of	31-51
reports of shore communication stations	31-49
report of trans-Pacific high power radio stations	31-50
Installation, battleships, acceptor-rejector circuit	31-634
defects, radio compass	31-997
of communication equipment	31-4
radio, F-5-L	31-412
receivers	31-491
receivers	31-633
Installations, destroyer, acceptor-rejector circuits	31-927 to 31-928
radio compass, ships	31-929 to 31-948
shore stations	31-4
Instructions, technical, communication facilities	31-961
to calibrating vessel, radio compass, ships	31-274
20-kilowatt arc transmitter	31-928
Instruments, arrangement of radio compass, ships	31-945, 31-970
shore radio compass stations	31-149
switchboard, 500-cycle quenched spark transmitter	31-186
Interference, auxiliary spark transmitter	31-151
elimination of	31-735
failure to suppress, tuned telephone	31-679
Intermediate circuit, model RB receiving equipment	31-427 to 31-430
Interphones, aircraft	31-361
Interphone unit, model TC vacuum tube transmitter	31-358
Interrupted continuous wave transmission	31-326, 31-359
vacuum-tube transmitter	31-42
Inventory, communication stations	31-9
Isolated communication stations	31-52
Items reported on, communication stations	31-52
K.	
Key, break, auxiliary spark transmitter	31-471
Morse	31-474
relay, transmitting, 20-kilowatt arc transmitter	31-269
to list of shore communication stations	31-63
transmitting, relay, 20-kilowatt arc transmitter	31-269
unipulse, arc transmitter	31-259, 31-268
Kite antenna, emergency, aircraft	31-481 to 31-485
L.	
Lamps, ballast	31-815
Large planes, radio receiving equipment	31-422
Layout, shore radio compass stations	31-936
Leak, grid condenser and	31-469
Life and property, preservation of, communication facilities	31-7
of batteries, SE235A	31-832
vacuum tubes	31-371
vacuum tubes	31-36
Light-vessels radio stations	31-123
Lightning switch, 500-cycle quenched spark transmitter	31-893
Lights, field set	31-284
Lining up anode tip, 20-kilowatt radio transmitter	31-62
List of shore communication stations	31-371
transmitting vacuum tubes	31-64
Living quarters, communication stations	31-637
loading coil, antenna, acceptor-rejector circuit	31-167
auxiliary spark transmitter	31-121, 31-136, 31-147
inductance, antenna, quenched spark transmitter	31-267
20-kilowatt arc transmitter	31-267

	Article.
Local metal, bodies, influence on shore radio compass, ships	31-998
radio compass stations	31-952
Location for radio receivers	31-431
of auxiliary antenna	31-186
loop, radio compass, ships	31-923
model point of potential, acceptor-rejector circuits	31-632
shore radio compass station	31-929, 31-936
Long-wave receiver, model RB receiving equipment	31-638
Loop circuit, model RB receiving equipment	31-636
coupling, aircraft radio receivers	31-479
model RB receiving equipment	31-634
radio compass	31-907, 31-928
receiving, amplification used in	31-525
Loud hissing, model RB receiving equipment	31-697
Low power operation, 20-kilowatt arc transmitter	31-276
Low resistance circuits, effect of, radio compass	31-313
M.	
Main line contactors, adjustment of, arc transmitter	31-290
Maintenance, communication facilities	31-1
of communication equipment	31-4
oscillations, model TC vacuum tube transmitter	31-352
Marine Corps detachment, communication stations, part of	31-34
field set, communication	31-35
Masts, portable field sets	31-879, 31-885
Material inspection of communication stations, scope of	31-51
Maximum method, radio compass, aircraft	31-909
output, adjustment for, vacuum tube transmitter	31-331
power adjustment, quenched spark transmitter	31-133
Measurements, audibility	31-490
Medium wave receiver, acceptor-rejector circuits	31-649
Metal bodies near-by radio compass, ships	31-950
shore radio compass stations	31-998
Meters, auxiliary spark transmitter	31-175
Method of calibrating radio compass, ships	31-952
Mica gaskets, quenched gap	31-145
Minima, defects of, radio compass	31-984
quality of, radio compass ships	31-927
Minor repairs, communication stations	31-38
Miscellaneous radio apparatus	31-806 to 31-823
Mission of the Bureau of Engineering, communication facilities	31-7
Modulation, failure of, model TC vacuum tube transmitter	31-367
model TC vacuum tube transmitter	31-355 to 31-357
vacuum tube transmitters	31-336
Modulator tubes, aircraft vacuum tube transmitters	13-414
Model E acceptor-rejector equipment	31-634 to 31-635, 31-654, 31-656 to 31-658
F acceptor-rejector equipment	31-634 to 31-635, 31-654, 31-656 to 31-658
R acceptor-rejector equipment	31-634, 31-653 to 31-655, 31-657 to 31-658
RB receiving equipment	31-675 to 31-698
TB radio telephone equipment	31-339 to 31-348
TC vacuum tube transmitter	31-349 to 31-369
Monthly Report, communication installations	31-79, 31-80
Morse key	31-174
Motor buzzer circuit	31-209
relay	31-210
transmitters	31-200, to 31-223
field sets	31-883
generator, 500-cycle quenched spark transmitter	31-113, 31-136, 31-139
speed regulator, motor buzzer	31-214
starting panel, 20-kilowatt arc transmitter	31-265
Mounting, motor buzzer	31-215
tube, receivers	31-467

N.

	Article.
Naval Communication Service, administration.....	31-3, 31-8
functioning.....	31-8
Necessity for calibration of shore radio compass stations.....	31-968
radio compass, ships.....	31-949
Nettings for beds, communication stations.....	31-68
Nodal point of potential, acceptor-rejector circuits.....	31-632
Nonoscillating condition, vacuum tube detector.....	31-560
Note, poor, motor-buzzer, reason for.....	31-226

O.

Observer, calibration of radio compass, ships.....	31-959
Officer in charge of communication station, accountability of.....	31-43
responsibility of.....	31-41
Open circuits, radio compass.....	31-986
receivers.....	31-497
telephone, radio.....	31-865
wavemeters.....	31-771
Open or short circuits, SE 1440 receiver.....	31-991
Operating requirements, receivers.....	31-471
Operation, efficiency of, communication stations.....	31-56
of acceptor-rejector circuits.....	31-652 to 31-657
aircraft radio compass coil.....	31-426
arc transmitters.....	31-274 to 31-294
audio-frequency amplifier.....	31-530
auxiliary spark transmitters.....	31-177 to 31-181
batteries, SE 3535A.....	31-853
Chaffee gap transmitters, aircraft.....	31-411
crystal detectors.....	31-89
emergency kite antenna, aircraft.....	31-431 to 31-435
field sets.....	31-884 to 31-889
heterodyne.....	31-590 to 31-592
interphones, aircraft.....	31-428
model RB receiving equipment.....	31-692 to 31-693
TC vacuum tube transmitter.....	31-363 to 31-364
power storage batteries, radio equipment.....	31-864
radio compass coil, aircraft.....	31-423
receivers.....	31-471 to 31-490
wavemeters.....	31-763 to 31-766
SE 1000 series amplifier.....	31-993
1210 receiver.....	31-992
1440 receiver and amplifier.....	31-991
1600 amplifier.....	31-993
1762 compensating condenser.....	31-994
motor buzzer transmitter.....	31-217 to 31-224
radio compass.....	31-981 to 31-983
synchronous spark transmitters, aircraft.....	31-408
telephones.....	31-804
tuned telephone.....	31-733 to 31-734
vacuum tube detectors.....	31-560 to 31-566
tubes, receiving.....	31-812
tube transmitters, aircraft.....	31-414
500-cycle quenched spark transmitter.....	31-129 to 31-133
provisions for, communication facilities.....	31-125
Optimum coupling, receiver.....	31-479
Oscillating current, amplitude of, arc transmitter.....	31-258
vacuum tube circuit, typical.....	31-323
Oscillation, conditions for, vacuum tube transmitter.....	31-330
factors affecting, receivers.....	31-478
radio compass.....	31-227
test, receivers.....	31-464, 31-477

	Article.
Oscillations, antenna.....	31-191, 31-197
failure of, model TC vacuum tube transmitter.....	31-355
heterodyne.....	31-593 to 31-594
stop, tuned telephone.....	31-73 ²
Oscillator, model TC vacuum tube transmitter.....	31-351
3-electrode vacuum-tube.....	31-327
Other bureaus, communication facilities, activities in connection with.....	31-15
Output, maximum, adjustment for, vacuum tube transmitter.....	31-331
model TB radio telephone equipment.....	31-345
variation of, with plate voltage, vacuum tubes.....	31-333

P.

Panel, antenna ammeter, motor buzzer transmitter.....	31-213
motor starting, 20-kilowatt arc transmitter.....	31-295
Parallax, calibration of radio compass, ships.....	31-953
Parallel and series oscillatory circuits, combination, acceptor-rejector.....	31-659
oscillatory circuit acceptor-rejector circuits.....	31-629
Parts, auxiliary spark transmitters.....	31-151
Party, calibrating, shore radio compass stations.....	31-972 to 31-973
Patents.....	31-4
Peculiarities of continuous-wave transmission, aircraft.....	31-417
arc transmitter operation.....	31-293
Pelorus, calibration of radio compass, ships.....	31-957
Performance data, shore radio compass stations.....	31-947
Phase requirements in oscillating vacuum tube circuits.....	31-329
Pick-up work, receivers.....	31-487
Plans for calibration, radio compass, ships.....	31-953 to 31-961
Plant of communication station, efficiency of.....	31-53
Plate and filament supply, heterodyne.....	31-591
current, model TB radio telephone equipment.....	31-344
voltage, model TB radio telephone equipment.....	31-344
receivers.....	31-474
switch, vacuum-tube detector.....	31-559
vacuum-tubes, receiving.....	31-812
Plotting the data, calibration of shore radio compass stations.....	31-973
Plug contacts defective, wavemeters.....	31-773
Points of reference, shore radio compass stations.....	31-931
Polarity and voltage of batteries, radio compass.....	31-939
Pole pieces, 20-kilowatt arc transmitter.....	31-256
Poor amplification, audio frequency.....	31-531
Portable mast, field sets.....	31-879, 31-885
Potentiometer, vacuum-tube detector.....	31-557
Power, batteries, radio compass.....	31-924
equipment, 20-kilowatt arc transmitter.....	31-235
low, 20-kilowatt arc transmitter.....	31-276
model TC vacuum-tube transmitter.....	31-359
motor buzzer transmitter.....	31-295, 31-212
plant, radio compass shore stations.....	31-922
aircraft radio transmitters.....	31-394
rating of, vacuum-tubes.....	31-334
storage batteries, radio equipment.....	31-591 to 31-594
supply, emergency.....	31-850
systems, field sets.....	31-833
unit, 500-cycle quenched spark transmitter.....	31-104
field sets.....	31-883
model TC vacuum-tube transmitter.....	31-392
Precautions, general, arc transmitter.....	31-237
auxiliary spark transmitter.....	31-185
500-cycle quenched spark transmitter.....	31-143
model TC vacuum-tube transmitter.....	31-359
in taking bearings by radio compass.....	31-933
Preparatory to flight, tests, aircraft radio equipment.....	31-416

	Article.
Preservation of life and property, communication facilities.....	31-7
Primary circuit, auxiliary spark transmitter.....	31-153, 31-155
tuning, auxiliary spark transmitter.....	31-178
fittings, auxiliary spark transmitter.....	31-165
Principle of double reception, acceptor-rejector circuits.....	31-633
beat reception, heterodyne.....	31-579
Procedure, calibration of radio compass, ships.....	31-962
shore radio compass stations.....	31-976
in taking bearings by radio compass.....	31-981 to 31-983
to operate model RB receiving equipment.....	31-692 to 31-693
Program of expenditures, communication facilities.....	31-23
Projects, public works, communication facilities.....	31-21
Protective devices, auxiliary spark transmitter.....	31-163
500-cycle quenched spark transmitter.....	31-124
relay, receiver, acceptor-rejector circuits.....	21-613
spark gap, acceptor-rejector circuit.....	31-614
Provisions for operation, communication facilities.....	31-12
Public works and radio material officers, cooperation between.....	31-25
projects, communication facilities.....	31-24
Purpose of acceptor-rejector circuits.....	31-625
amplifiers, receiving.....	31-525
batteries, radio equipment.....	31-850
condensers.....	31-816
crystal detectors.....	31-596
field sets.....	31-875
miscellaneous radio apparatus.....	31-800
model RB radio receiving equipment.....	31-675
power storage batteries, radio equipment.....	31-862
radio compass.....	31-960
radio-frequency driver or heterodyne.....	31-575
tuned telephone.....	31-725
vacuum tube detectors.....	31-550
wavemeters.....	31-750

Q.

Quality of minima, radio compass, ships.....	31-927
Quarterly report, communication installation.....	31-75 to 31-78
Quarters, communication stations.....	31-64
Quenched gap.....	31-105, 31-117, 31-106, 31-145
spark transmitter.....	31-103 to 31-149
aircraft.....	31-409

R.

R model, acceptor-rejector equipment.....	31-661, 31-633 to 31-655, 31-657 to 31-658
RB model, receiving equipment.....	31-675 to 31-698
Radiation, motor-buzzer transmitter.....	31-206
quenched spark transmitter.....	31-107
Radio apparatus, miscellaneous.....	31-800 to 31-823
audio frequency amplifier, model RB receiving equipment.....	31-690
amplifiers.....	31-532 to 31-538
communication with extension station, establishing, model TC.....	31-364
compass, aircraft.....	31-424 to 31-426
bearings, taking of.....	31-981 to 31-983
correction sheets for, ships.....	31-967
calibration curve, ships.....	31-966 to 31-967
data form, ships.....	31-959
ships.....	31-949 to 31-967
coil, aircraft.....	31-423
direct-current resistance of.....	31-995
defects, causes of, ships.....	31-952 to 31-953
equipment.....	31-900 to 31-998
installations, ships.....	31-927 to 31-928
shore stations.....	31-929 to 31-945

	Article.
Radio compass, report of calibration of.....	31-83, 31-84
stations, shore, calibration of.....	31-968 to 31-980
shore, report of calibration of.....	31-980
tests.....	31-987 to 31-998
division, Bureau of Engineering.....	31-4, 31-20
equipment, aircraft.....	31-400 to 31-435
tests preparatory to flight.....	31-416
frequency currents, tests for, in radio compass communication lines.....	31-996
driver, model RB receiving equipment.....	31-689
driver, or heterodyne.....	31-575 to 31-594
helmet.....	31-430
installation, F-5-L.....	31-412
material officer and public works, cooperation between.....	31-26
assignment of.....	31-10
duties of.....	31-14
function of.....	31-13
receiving equipment, aircraft.....	31-418 to 31-430
large planes.....	31-422
stations, light vessels.....	31-36
telephone, model TB.....	31-339
Rating power of vacuum tubes.....	31-334
Rattail, field sets.....	31-680
Reactance, auxiliary spark transmitter.....	31-179
coil, 500-cycle circuit, quenched spark transmitter.....	31-114
Receive, failure to, model TC vacuum tube transmitter.....	31-368
position, auxiliary spark transmitter relay.....	31-177
Receiver and amplifier, SE 1440, operation of.....	31-990
transmitter inductance.....	31-178
batteries, radio compass.....	31-925
calibration of, shore radio compass stations.....	31-969
field sets.....	31-882, 31-887
long-wave, model RB.....	31-688
medium wave, acceptor-rejector circuits.....	31-649
model TC vacuum tube transmitter.....	31-360
protective relay, acceptor-rejector circuits.....	31-648
radio compass, defects in.....	31-986
SE 1210, operation of.....	31-992
Receiving equipment, model RB receiving equipment.....	31-675 to 31-698
vacuum tubes.....	31-811 to 31-815
Receivers, single-unit aircraft.....	31-419 to 31-420
Receiving equipment, aircraft radio.....	31-418 to 31-430
model TC, vacuum tube transmitter.....	31-363
Reception, autodyne, vacuum-tube detectors.....	31-562
Records, shore radio compass stations.....	31-946 to 31-948
Reduction of static, model RB receiving equipment.....	31-681
Reference points, shore radio compass stations.....	31-934
Regeneration, vacuum-tube detectors.....	31-561
Regulator, motor speed, motor buzzer transmitter.....	31-214
Rejector condenser, acceptor-rejector circuits.....	31-640
inductance, acceptor-rejector circuits.....	31-641
shunt, acceptor-rejector circuits.....	31-639
use of, auxiliary spark transmitter.....	31-186
Relay, double contact, 20-kilowatt arc transmitter.....	31-273
key, 20-kilowatt arc transmitter.....	31-269
500-cycle, quenched spark transmitter.....	31-115
motor-buzzer transmitter.....	31-210
receiver, protective, acceptor-rejector circuits.....	31-648
Reliability, aircraft radio apparatus.....	31-405 to 31-406
Remedies, faults, acceptor-rejector circuits.....	31-658 to 31-663
aircraft radio equipment.....	31-417
arc transmitter.....	31-295 to 31-296
audio-frequency amplifiers.....	31-531
batteries for radio equipment.....	31-855

	Article.
Remedies, faults, condensers	31-819 to 31-820
crystal detectors	31-810
field sets	31-890 to 31-896
heterodyne	31-593
model RB receiving equipment	31-694 to 31-698
TB radio telephone equipment	31-348
TC vacuum tube transmitter	31-365 to 31-369
power storage batteries, radio equipment	31-864
radio-audio-frequency amplifiers	31-538
compass	31-984 to 31-986
receivers	31-497 to 31-500
telephones	31-805
tuned telephone	31-735 to 31-737
vacuum-tube detectors	31-565 to 31-566
vacuum-tubes, receiving	31-813
wavemeters	31-767 to 31-772
for interference, auxiliary spark transmitter	31-186
Repairs and alterations, communication facilities	31-4
by shore communication station personnel	31-37
communication facilities	31-25
request for	31-59
to receivers	31-495
Replacing anode tip, 20-kilowatt arc transmitter	31-284
carbon, 20-kilowatt arc transmitter	31-286
Report, annual, on communication activities, commander in chief	31-70
installation alterations	31-72, 31-74
district craft	31-73
shore communication stations	31-71
by communication station officer on taking charge	31-44
monthly communication installations	31-79, 31-80
of calibration of radio compass, ship and shore	31-83, 31-84
shore radio compass stations	31-980
changes in communication installations	31-72, 31-74
inspections of shore communication stations	31-49
inspection of Trans-Pacific high power stations	31-50
material inspection of communication stations, scope of	31-51
quarterly communication installations	31-75 to 31-78
Reports, communication activities	31-69 to 31-85
concerning other departments, inspection of communication stations	31-55
Requests and requisitions, communication stations, routing of	31-58
for repairs, communication stations	31-59
Requirement, aircraft radio equipment	31-401
operating, aircraft radio receivers	31-471
Requirements, radio telephone	31-350
Requisitions and requests, communication stations	31-58
communication facilities	31-4
Research, communication facilities	31-4
Resistance, absorbing circuit, 20-kilowatt arc transmitter	31-270
characteristic of arc	31-255
of radio compass coil, direct-current	31-095
power changing, motor buzzer transmitter	31-212
radio compass	31-913
Resonance indicating devices, wavemeters	31-752
indication of, wavemeters	31-753
Resonant frequency of 500-cycle circuit, method of finding	31-130
Responsibility, Bureau of Engineering, shore communication stations	31-28
of officer in charge of communication station	31-41
Retuning radio-frequency circuits	31-146
Rheostat, filament, vacuum-tube detectors	31-554
Rheostats, 500-cycle quenched spark transmitter	31-115

	Articles.
Rigging, ship's radio compass.....	31-923, 31-952
spark in.....	31-186
Rotary gap.....	31-117, 31-136, 31-146

S.

Safety-spark gap.....	31-114
Scope of Manual, communication facilities.....	31-4
material inspection, communication stations.....	31-51
yards, communication facilities.....	31-10
SE 1000 series amplifier, operation of.....	31-993
1210 receiver, operation of.....	31-992
1440 receiver and amplifier, operation of.....	31-991
open or short circuit.....	31-991
1800 amplifier, operation of.....	31-993
1762 compensating condenser.....	31-994
Search for signals.....	31-456
Second stage of amplification, audio frequency.....	31-527
Secondary circuit, receivers.....	31-458
model RB receiving equipment.....	31-680
tuning, receivers.....	31-480 to 31-482
Securing arc, 20-kilowatt arc radio transmitter.....	31-240
Selection by audio-frequency tuning, tuned telephone.....	31-727
of signals, acceptor-rejector circuits.....	31-626
Selectivity, acceptor-rejector circuits.....	31-661
aids to, model RB receiving equipment.....	31-677
Send position, auxiliary spark transmitter relay.....	31-177
Send-receive adjustment, auxiliary spark transmitter relay.....	31-177
switch, 500-cycle quenched spark transmitter.....	31-122
and parallel oscillatory circuits, combination of, acceptor-rejector.....	31-350
Series field coils, 20-kilowatt arc transmitter.....	31-236
oscillatory circuit, acceptor-rejector circuits.....	31-623
SE 1000 amplifier, operation of.....	31-993
Service wavemeters.....	31-756
Setting the dial, calibration of radio compass, ships.....	31-934
stations, shore.....	31-371
stations, shore.....	31-253
Sheath, cathode, 20-kilowatt arc transmitter.....	31-367
Sheets, correction, for radio compass bearings, ships.....	31-452
Shield, coupling coil, receivers.....	31-341
Shielding, arrangement, model T B radio telephone equipment.....	31-333
radio-audio-frequency amplifiers.....	31-928
compass, ships.....	31-933
stations, shore.....	31-460
receivers.....	31-16
Ships, communication facilities, activities with.....	31-928, 31-952
Ship's rigging, radio compass.....	31-300 to 31-923, 31-949 to 31-967, 31-981 to 31-998
Ship stations, radio compass.....	31-968 to 31-990
Shore radio compass stations, calibration of.....	31-27
station, communication.....	31-316
stations' equipment, radio compass.....	31-18
units, aircraft, communication facilities, activities with.....	31-17
communication facilities, activities with.....	31-62
communication stations, list of.....	31-49
reports of inspection of.....	31-28
Bureau of Engineering responsibility at.....	31-20
activities, communication facilities.....	31-71
communication stations, annual report.....	31-990 to 31-996, 31-929 to 31-948, 31-963 to 31-990
stations, radio compass.....	31-497 to 31-495
Short circuits, receivers.....	31-931
radio compass coil.....	31-931
or open circuits, SE 1440 receiver.....	31-931
Shunt, rejector, acceptor-rejector circuits.....	31-60

	Article.
Signal and static die out, model RB receiving equipment.....	31-696
Service, Coast.....	31-1
stops, model RB receiving equipment.....	31-696
Signaling systems, arc transmitter.....	31-259
Silence, zone of, radio compass.....	31-910
Simple arc circuit.....	31-256
Single-circuit receiver, aircraft.....	31-419 to 31-420
Site, radio field sets.....	31-884
Space requirements, radio compass, ships.....	31-928
Spark frequency, motor-buzzer transmitter.....	31-207
gap, auxiliary spark transmitter.....	31-164
500-cycle quenched-spark transmitter.....	31-117, 31-136
gaskets.....	31-145
motor buzzer transmitter.....	31-221, 31-224, 31-227
protective, acceptor-rejector circuits.....	31-644
rotary.....	31-146
synchronous, transmitter, aircraft.....	31-407 to 31-408
transmitter, auxiliary.....	31-150 to 31-186
transmitters.....	31-100 to 31-228
Sparkling at key contacts, arc transmitter.....	31-294
in rigging.....	31-186
surface, gap.....	31-145
Special requirements, aircraft radio equipment.....	31-401
Speed of vessels, calibration of radio compass ships.....	31-960
regulation, motor, motor-buzzer transmitter.....	31-214
Stabilizer, radio-audio-frequency amplifier.....	31-536
Stand-by work, receivers.....	31-486
Standard allowance of furniture, communication stations.....	31-65
wavemeters.....	31-757
500-cycle quenched-spark transmitter.....	31-103 to 31-149
Starting arc, 20-kilowatt arc transmitter.....	31-279
engine, field set.....	31-888, 31-902
panel, motor, 20-kilowatt arc transmitter.....	31-265
20-kilowatt arc transmitter.....	31-275
Static method of tuning receivers.....	31-483
reduction, model RB receiving equipment.....	31-681
tuned telephone.....	31-727
Stations, ship, radio compass.....	31-900 to 31-928, 31-949 to 31-967, 31-981 to 31-998
shore, radio compass.....	31-600 to 31-926, 31-929 to 31-948, 31-968 to 31-998
Stepping mast, field sets.....	31-885
Stopping arc, 20-kilowatt arc transmitter.....	31-278
Storage batteries, power.....	31-861 to 31-864
radio compass.....	31-924 to 31-925
equipment.....	31-850 to 31-864
Striking mast, field sets.....	31-886
Structures, shore radio compass stations.....	31-933, 31-935 to 31-937
Superintendents, communication, expenses of.....	31-39
Supervision, radio compass.....	31-905
Supervisor, Trans-Pacific high power circuit.....	31-40
Supply circuit, motor buzzer transmitter.....	31-205
of hydrocarbon, 20-kilowatt arc transmitter.....	31-291
Surface, gap sparking, 500-cycle, quenched-spark transmitter.....	31-145
Surrounding structures, radio compass, ships.....	31-927
Surroundings, shore radio compass stations.....	31-932 to 31-933
Switch, crystal-audion, receivers.....	31-466
inductance, receivers.....	31-465
lightning, 500-cycle quenched-spark transmitter.....	31-123
plate voltage, vacuum-tube detector.....	31-559
send-receive.....	31-122, 31-142
transfer, 500-cycle quenched-spark transmitter.....	31-116, 31-142
tuned telephone.....	31-732

	Articles.
Switchboard, 500-cycle quenched-spark transmitter.....	31-115, 31-136
instruments, 500-cycle.....	31-140
20-kilowatt arc.....	31-265
Switches, 20-kilowatt arc.....	31-265
Symmetry with respect to hull, radio compass.....	31-928
Synchronous spark transmitter, aircraft.....	31-407 to 31-408

T.

TB model, radio telephone equipment.....	31-339 to 31-348
TC model, vacuum-tube transmitter.....	31-349 to 31-369
Telephone condenser setting, receivers.....	31-175
cords, radio-frequency amplifiers, shielded.....	31-536
radio, model TB equipment.....	31-339 to 31-345
vacuum-tube transmitter.....	31-326, 31-336
transmission, model TC vacuum-tube transmitter.....	31-354
tuned.....	31-725 to 31-729
acceptor-rejector circuit.....	31-633
Telephones, radio compass.....	31-926
types of.....	31-801
Test buzzer, receivers.....	31-470
for minimum, shore radio compass stations.....	21-943
oscillations, shore radio compass stations.....	31-942
of communication lines, shore radio compass stations.....	31-996
installation, radio compass, ships.....	21-923
preparatory to flight, aircraft radio equipment.....	31-416
31-4	
Testing of communication equipment.....	31-415
radio equipment, aircraft.....	31-20
Tests, communication facilities.....	31-854
of batteries, SE 3535 A.....	31-987 to 31-998
radio compass.....	31-627 to 31-633
Theory of acceptor-rejector circuits.....	31-808
crystal detectors.....	31-877
field sets.....	31-579 to 31-581
heterodyne.....	31-579, 31-581
radio-frequency driver at heterodyne.....	31-803
telephones.....	31-254 to 31-263
the arc transmitter.....	31-527
audio-frequency amplifier.....	31-152 to 31-155
auxiliary spark transmitter.....	31-103 to 31-108
500-cycle quenched-spark transmitter.....	31-678 to 31-581
model RB receiving equipment.....	31-350 to 31-353
TC vacuum-tube transmitter.....	31-203 to 31-208
motor-buzzer transmitter.....	31-524
radio-audio-frequency amplifier.....	31-906 to 31-913
compass.....	31-727
tuned telephone.....	31-327 to 31-336
vacuum-tube transmitter.....	31-769
Thermo-galvanometer, wavemeters.....	31-327
Three-electrode vacuum tube as oscillator.....	31-523
Three-stage audio-frequency amplifier.....	31-476, 31-481
Ticker (back coupler) adjustment, receiver.....	31-555
vacuum tube detector.....	31-453, 31-464, 31-481
receiver.....	31-234
Tip, anode, lining up, 20-kilowatt arc transmitter.....	31-234
replacing, 20-kilowatt arc transmitter.....	31-46
Transfer of communication station officer.....	31-116
switch, 500-cycle quenched-spark transmitter.....	31-732
tuned telephone.....	31-283
20-kilowatt arc transmitter.....	31-217, 31-219
to motor buzzer from quenched spark.....	31-114, 31-136, 31-144
Transformer, 500-cycle quenched-spark transmitter.....	31-526
Transformers, radio-frequency amplifier.....	

	Articles.
Transforming circuit, current, arc transmitter.....	31-260
Transmission, continuous wave, arc transmitter.....	31-251
radio aircraft.....	31-417
telegraph model TC vacuum tube transmitter.....	31-353
telephone, model TC vacuum-tube transmitter.....	31-354
Transmitter arc.....	31-250 to 31-297
20-kilowatt.....	31-264 to 31-273
Chaffee gap, aircraft.....	31-409 to 31-411
field set.....	31-882, 31-887
model TC vacuum tube.....	31-349 to 31-369
motor buzzer.....	31-200 to 31-228
quenched spark, aircraft.....	31-409
synchronous spark, aircraft.....	31-407 to 31-408
spark.....	31-100 to 31-228
spark, auxiliary.....	31-150 to 31-186
tuning, quenched spark.....	31-131, 31-146
radio compass, ships.....	31-927
vacuum-tube, aircraft.....	31-413
wave length, determination of, by wavemeter.....	31-763
Transmitting apparatus, aircraft radio equipment.....	31-407 to 31-417
condensers, auxiliary spark transmitter.....	31-165
key, 20-kilowatt arc transmitter.....	31-259
model TC vacuum tube transmitter.....	31-363
vacuum-tubes.....	31-370, 31-371
Trans-Pacific high-power stations, inspection, report of.....	31-50
circuit, Supervisor.....	31-40
Tube circuit, typical oscillating, vacuum.....	31-328
mounting, receivers.....	31-467
radio compass ship stations.....	31-921
Tube, vacuum, transmitters.....	31-325 to 31-371
3-electrode.....	31-327
Tubes, vacuum, model TB radio telephone equipment.....	31-344
transmitting.....	31-370, 31-371
Tuned telephone, acceptor-rejector circuits.....	31-633, 31-726
circuit.....	31-725 to 31-737
Tuning, aircraft radio receivers.....	31-420
and adjustments, high-power, 500-cycle circuit.....	31-132, 31-146
antenna, receivers.....	31-483
auxiliary spark transmitter.....	31-178
condenser, antenna, acceptor-rejector circuits.....	31-647
heterodyne.....	31-592
inductance, antenna, acceptor-rejector circuits.....	31-636, 31-646
motor buzzer, transmitter.....	31-217
secondary, receivers.....	31-480, 31-482
the 500-cycle circuit.....	31-129, 31-146
transmitter, 500-cycle quenched spark transmitter.....	31-131, 31-146
transmitter, radio compass.....	31-927
tuned telephone.....	31-733
unit, barrage, model RB receiving equipment.....	31-685
Tunnel, wind, emergency kite antenna, aircraft.....	31-432
Twenty-kilowatt arc transmitter.....	31-264 to 31-27
Types of acceptor-rejector equipment.....	31-634
aircraft radio receivers.....	31-418 to 31-426
audio-frequency amplifiers.....	31-528
auxiliary spark transmitters.....	31-160
condensers.....	31-817
crystal detectors.....	31-907
equipment, radio compass.....	31-914, 31-918
furniture, communication stations.....	31-67
radio-frequency drivers, or heterodyne.....	31-581
motor buzzers.....	31-202
power storage batteries, radio equipment.....	31-863

	Article.
Types of radio-audio-frequency amplifiers.....	31-535
receivers.....	31-453
service wavemeters.....	31-756
telephones.....	31-891
vacuum tubes, aircraft radio receivers.....	31-472
tube transmitters.....	31-326, 31-337
standard, 500-cycle quenched spark transmitters.....	31-108
Typical oscillating vacuum tube circuit.....	31-328
U.	
Underground cables, shore radio compass stations.....	31-940
Uniwave key, arc transmitter.....	31-259
system, arc transmitter.....	31-259, 31-268, 31-294
Use of batteries, SE 3535A.....	31-856
detector and telephones, wavemeter.....	31-765
radio-frequency driver or heterodyne.....	31-376
tuned telephone.....	31-725
vacuum-tube detector.....	31-551
wavemeter, radio compass.....	31-987
with low power radio transmitter.....	31-764
V.	
Vacuum tube aircraft radio transmitters.....	31-413 to 31-417
detectors.....	31-550 to 31-566
heterodyne.....	31-586
supply, battery.....	31-850
support, detectors.....	31-552
transmitters.....	31-325 to 31-371
3-electrode.....	31-327
Vacuum-tubes for radio-audio-frequency amplifiers.....	31-537
model TB radio telephone equipment.....	31-344
receiving.....	31-811 to 31-815
transmitting.....	31-370, 31-371
types of, receivers.....	31-472
Variation of output with plate voltage, vacuum-tubes.....	31-335
Variometer, 500-cycle quenched spark transmitter.....	31-120
Visible sector, calibration of, shore radio compass station.....	31-977
Voltage, plate, receivers.....	31-474
model TB radio telephone equipment.....	31-344
vacuum tubes, receiving.....	31-812
W.	
Water cooling, 20-kilowatt arc transmitter.....	31-266, 31-287
Wave changer, 500-cycle quenched spark transmitter.....	31-119, 31-136, 31-147
continuous, transmission, arc transmitter.....	31-251
length of absorbing circuit, arc transmitter.....	31-294
secondary, receivers.....	31-481
transmitter, determination of, by wavemeter.....	31-763
range, wavemeters.....	31-759
to adjust, 20-kilowatt arc transmitter.....	31-282
change 20-kilowatt arc transmitter.....	31-281
Wave lengths, heterodyne.....	31-588
motor buzzer, transmitter.....	31-218
radio compass.....	31-902, 31-927, 31-941
Wavemeter used as driver.....	31-755, 31-766
use of, radio compass.....	31-987
Wavemeters.....	31-750 to 31-772
service.....	31-756
standard.....	31-757
Wheel, buzzer.....	31-235, 31-210, 31-223, 31-225

	Article.
When to use tuned telephone	31-733
Where to calibrate radio compass, ships.....	31-956
Wind-driven generator, aircraft radio equipment.....	31-414
Wind tunnel, emergency kite antenna, aircraft	31-432
Winding transformer, secondary, 500-cycle quenched spark transmitter	31-114
Wiring, receivers	31-432

Y.

Yards, scope of communication facilities.....	31-10
---	-------

Z.

Zone of silence, radio compass stations.....	31-910
--	--------

