

★
NAVSHIPS 91131

INSTRUCTION BOOK

for

FREQUENCY SHIFT
MONITOR EQUIPMENTS
NAVY MODELS
OCT-2 AND OCT-3

HAZELTINE ELECTRONICS CORPORATION
NEW YORK, NEW YORK

BUREAU OF SHIPS

NAVY DEPARTMENT

★
Contract: NObsr-42028

Approved by BuShips: 3 SEPTEMBER 1948

LIST OF EFFECTIVE PAGES

Page Numbers	Change in Effect	Page Numbers	Change in Effect
Title Page	Original	4-1 to 4-5	Original
A to C	Original	5-0 to 5-2	Original
i to vii	Original	6-1 to 6-2	Original
1-0 to 1-5	Original	7-0 to 7-20	Original
2-0 to 2-12	Original	8-1 to 8-33	Original
3-1 to 3-6	Original	i-1 to i-5	Original



ADDRESS NAVY DEPARTMENT,
BUREAU OF SHIPS

NAVY DEPARTMENT
BUREAU OF SHIPS
WASHINGTON 25, D. C.

REFER TO FILE NO.

3 Sept. 1948

Code 993-100

To: All Activities concerned with the
Installation, Operation and Main-
tenance of the Subject Equipment.

Subj: Instruction Book for Frequency Shift
Monitor Equipment, Navy Models OCT-2
and OCT-3 (NAVSHIPS 91131)

1. NAVSHIPS 91131 is the instruction
book for the subject equipment and is in
effect upon receipt.

2. When superseded by a later edition,
this publication shall be destroyed.

3. Extracts from this publication may be
made to facilitate the preparation of other
Navy instruction books and handbooks.

4. All requests for NAVSHIPS Electronics
publications should be directed to the near-
est District Publications and Printing Office.
When changes or revised books are distributed,
notice will be included in the applicable main-
tenance bulletin and the ELECTRON Magazine.

E. W. MILLS
Chief of Bureau

FROM BUREAU OF SHIPS, NAVY DEPARTMENT, WASHINGTON 25, D. C.

TABLE OF CONTENTS**SECTION 1—GENERAL DESCRIPTION**

Paragraph	Page
1. Introduction.....	1-1
2. Frequency Shift Monitor Equipment, Navy Models OCT-2 and OCT-3.....	1-1
3. Equipment Supplied.....	1-3
4. Equipment Required but not Supplied.....	1-4
5. Shipping Data.....	1-4
6. Equipment Tube Complement.....	1-4
7. Interchangeability of Major Units.....	1-4
8. Reference Data.....	1-5

SECTION 2—THEORY OF OPERATION

1. Scope and Contents.....	2-0
2. The Main Signal Path.....	2-0
3. Input Tuning.....	2-0
4. The Local Oscillator and Frequency Multiplier.....	2-1
5. The Mixer and I-F Amplifier.....	2-2
6. The I-F Limiters.....	2-2
7. The Discriminator.....	2-2
8. The Indicator Circuits.....	2-3
9. Indicator Circuits—Tune Operation.....	2-3
10. Indicator Circuits—Unkeyed Signal Operation.....	2-5
11. Indicator Circuits—Keyed Signal Operation.....	2-6
12. The Calibrating Oscillator.....	2-7
13. The Power Supply.....	2-8
14. Operating Controls.....	2-8
15. Appendix—Frequency-Shift Telegraph System.....	2-10

SECTION 3—INSTALLATION

1. Scope and Contents.....	3-1
2. Types of Installation.....	3-1
3. Primary Power Source Requirements.....	3-1
4. Unpacking and Inspecting the Equipment.....	3-1
5. Readyng the Equipment.....	3-3
6. Installation of the Frequency Shift Monitor OCT-2.....	3-3
7. Installation of the Frequency Shift Monitor OCT-3.....	3-3
8. Checking the Installation.....	3-5

SECTION 4—OPERATION

1. Precautions to be Observed.....	4-1
2. Operating Procedure.....	4-1
3. The Meter Zero-Set Adjustment.....	4-1
4. The Calibration Adjustment.....	4-3
5. Frequency-Shift Measurement of Unkeyed Signals.....	4-3
6. Frequency-Shift Measurement of Keyed Signals.....	4-4

TABLE OF CONTENTS — Continued

SECTION 5—OPERATOR'S MAINTENANCE

Paragraph	Page
1. Routine Check Chart	5-0
2. Fuse Locations and Symptoms of Failure	5-0
3. Tube Replacement Data	5-1
4. Calibration Checking Procedure	5-2

SECTION 6—PREVENTIVE MAINTENANCE

1. General Maintenance Notes	6-1
2. Maintenance Test Schedule	6-1
3. Lubrication	6-2

SECTION 7—CORRECTIVE MAINTENANCE

1. Maintenance Procedures	7-1
2. General Notes on Trouble Shooting	7-1
3. Equipment Disassembly Instructions	7-2
4. Trouble Isolation and Repair	7-2
5. Servicing the Local Oscillator	7-4
6. Trouble Symptoms, Causes, and Remedies	7-6

SECTION B—PARTS LISTS

(See List of Tables)

LIST OF ILLUSTRATIONS**SECTION 1—GENERAL DESCRIPTION**

Figure	Title	Page
1-1.	Frequency Shift Monitor Equipment, Navy Models OCT-2 and OCT-3	1-0
1-2.	RF Monitor, Basic Block Diagram	1-2
1-3.	Frequency Shift Monitor OCT-2, Oblique View	1-2
1-4.	Frequency Shift Monitor OCT-3, Oblique View	1-3

SECTION 2—THEORY OF OPERATION

2-1.	RF Monitor, Block Diagram	2-1
2-2.	Indicator Circuits, Tune Operation	2-4
2-3.	Indicator Circuits, Unkeyed Operation	2-5
2-4.	Indicator Circuits, Keyed Operation	2-7
2-5.	Typical Frequency-Shift Block Diagram	2-11

SECTION 3—INSTALLATION

3-1.	Frequency Shift Monitor OCT-2, Installation Diagram	3-2
3-2.	Frequency Shift Monitor OCT-3, Installation Diagram	3-4
3-3.	Cable Connections Diagram	3-5
3-4.	Cable Fabrication Data	3-6

SECTION 4—OPERATION

4-1.	RF Monitor Operating Instructions	4-2
4-2.	Approximate Frequency Calibration Charts, Bands 1 and 2	4-4
4-3.	Approximate Frequency Calibration Charts, Bands 3 and 4	4-5

SECTION 5—OPERATOR'S MAINTENANCE

5-1.	RF Monitor, Tube Location Diagram	5-1
------	---	-----

SECTION 6—PREVENTIVE MAINTENANCE

6-1.	Lubrication Data	6-2
------	------------------------	-----

SECTION 7—CORRECTIVE MAINTENANCE

7-1.	Failure Report, Sample Form	7-0
7-2.	RF Monitor, Top View of Chassis	7-2
7-3.	RF Monitor, Bottom View of Chassis	7-3
7-4.	Servicing the Local Oscillator	7-5
7-5.	Vacuum-Tube Pin Connections Diagram; Resistance and Operating Voltage Chart	7-15
7-6.	RF Monitor, Schematic Diagram	7-17
7-7.	RF Monitor, Wiring Diagram	7-19

LIST OF TABLES**SECTION 1—GENERAL DESCRIPTION**

1-1. Equipment Supplied	1-3
1-2. Equipment Required but not Supplied	1-4
1-3. Shipping Data	1-4
1-4. Electron Tube Complement	1-4

SECTION 5—OPERATOR'S MAINTENANCE

5-1. Routine Check Chart	5-0
--------------------------------	-----

SECTION 6—PREVENTIVE MAINTENANCE

6-1. Maintenance Test Schedule	6-1
--------------------------------------	-----

SECTION 7—CORRECTIVE MAINTENANCE

7-1. Trouble Symptoms, Causes, and Remedies	7-6
7-2. Bench-Check Tests and Alignment Procedures	7-7
7-3. Winding Data	7-13

SECTION 8—PARTS LISTS

8-1. Weights and Dimensions of Uncrated Spare Parts Boxes	8-1
8-2. Shipping Weights and Dimensions of Crated Spare Parts Boxes	8-1
8-3. List of Major Units	8-1
8-4. Combined Parts and Spare Parts List	8-2
8-5. Cross Reference Parts List	8-31
8-6. Applicable Color Codes	8-32
8-7. List of Manufacturers	8-33

GUARANTEE

The Contractor guarantees that at the time of delivery thereof the articles provided for under this contract will be free from any defects in material or workmanship and will conform to the requirements of this contract. Notice of any such defect or non-conformance shall be given by the Government to the Contractor within one year of the delivery of the defective or non-conforming article, unless a different period of Guaranty is specified in the schedule. If required by the Government within a reasonable time after such notice, the Contractor shall with all possible speed correct or replace the defective or non-conforming article or part thereof. When such correction or replacement requires transportation of the article or part thereof, shipping costs, not exceeding usual charges, from the delivery point to the Contractor's plant and return, shall be borne by the Contractor; the Government shall bear all other shipping costs. This Guaranty shall then continue as to corrected or replacing articles or, if only parts of such articles are corrected or replaced, to such corrected or replacing parts, until one year after the date of redelivery, unless a different period of Guaranty is specified in the schedule. If the Government does not require correction or replacement of a defective or non-conforming article, the Contractor, if required by the contracting officer within a reasonable time after the notice of defect or non-conformance, shall repay such portion of the contract price of the article as is equitable in the circumstances.

INSTALLATION RECORD

Contract Number NObsr-42028

Date of Contract, 8 October 1947

Serial Number of equipment

Date of acceptance by the Navy

Date of delivery to contract destination

Date of completion of installation

Date placed in service

Blank spaces on this page shall be filled in at time of installation. Operating personnel shall also mark the "date placed in service" on the date of acceptance plate located below the model nameplate on the equipment, using suitable methods and care to avoid damaging the equipment.

REPORT OF FAILURE

Report of failure of any part of this equipment, during its entire service life, shall be made to the Bureau of Ships in accordance with current regulations using form NAVSHIPS NBS 383 (revise) except for Marine Corps equipment, in which case the "Signal Equipment Failure Report" form shall be used and distributed in accordance with instructions pertaining thereto. The report shall cover all details of the failure and give the date of installation of the equipment. For procedure in reporting failures see Chapter 67 of the *Bureau of Ships Manual* or superseding instructions.

ORDERING PARTS

All requests or requisitions for replacement material should include the following data:

1. Federal stock number or, when ordering from a Marine Corps or Signal Corps supply depot, the Signal Corps stock number.
2. Name and short description of part.

If the appropriate stock number is not available the following shall be specified:

1. Equipment model or type designation, circuit symbol, and item number.
2. Name of part and complete description.
3. Manufacturer's designation.
4. Contractor's drawing and part number.
5. JAN or Navy type number.

SAFETY NOTICE

The attention of officers and operating personnel is directed to Chapter 67 of the *Bureau of Ships Manual* or superseding instructions on the subject of radio-safety precautions to be observed.

This equipment employs voltages which are dangerous and may be fatal if contacted by operating personnel. Extreme caution should be exercised when working with the equipment.

While every practicable safety precaution has been incorporated in this equipment, the following rules must be strictly observed:

KEEP AWAY FROM LIVE CIRCUITS:

Operating personnel must at all times observe all safety regulations. Do not change tubes or make adjustments inside equipment with high voltage supply on. Under certain conditions dangerous potentials may exist in circuits with power controls in the off position due to charges retained by capacitors. To avoid casualties always remove power and discharge and ground circuits prior to touching them.

DON'T SERVICE OR ADJUST ALONE:

Under no circumstances should any person reach within or enter the enclosure for the purpose of servicing or adjusting the equipment without the immediate presence or assistance of another person capable of rendering aid.

RESUSCITATION

AN APPROVED POSTER ILLUSTRATING THE RULES FOR RESUSCITATION BY THE PRONE PRESSURE METHOD SHALL BE PROMINENTLY DISPLAYED IN EACH RADIO, RADAR OR SONAR ENCLOSURE. POSTERS MAY BE OBTAINED UPON REQUEST TO THE BUREAU OF MEDICINE AND SURGERY.

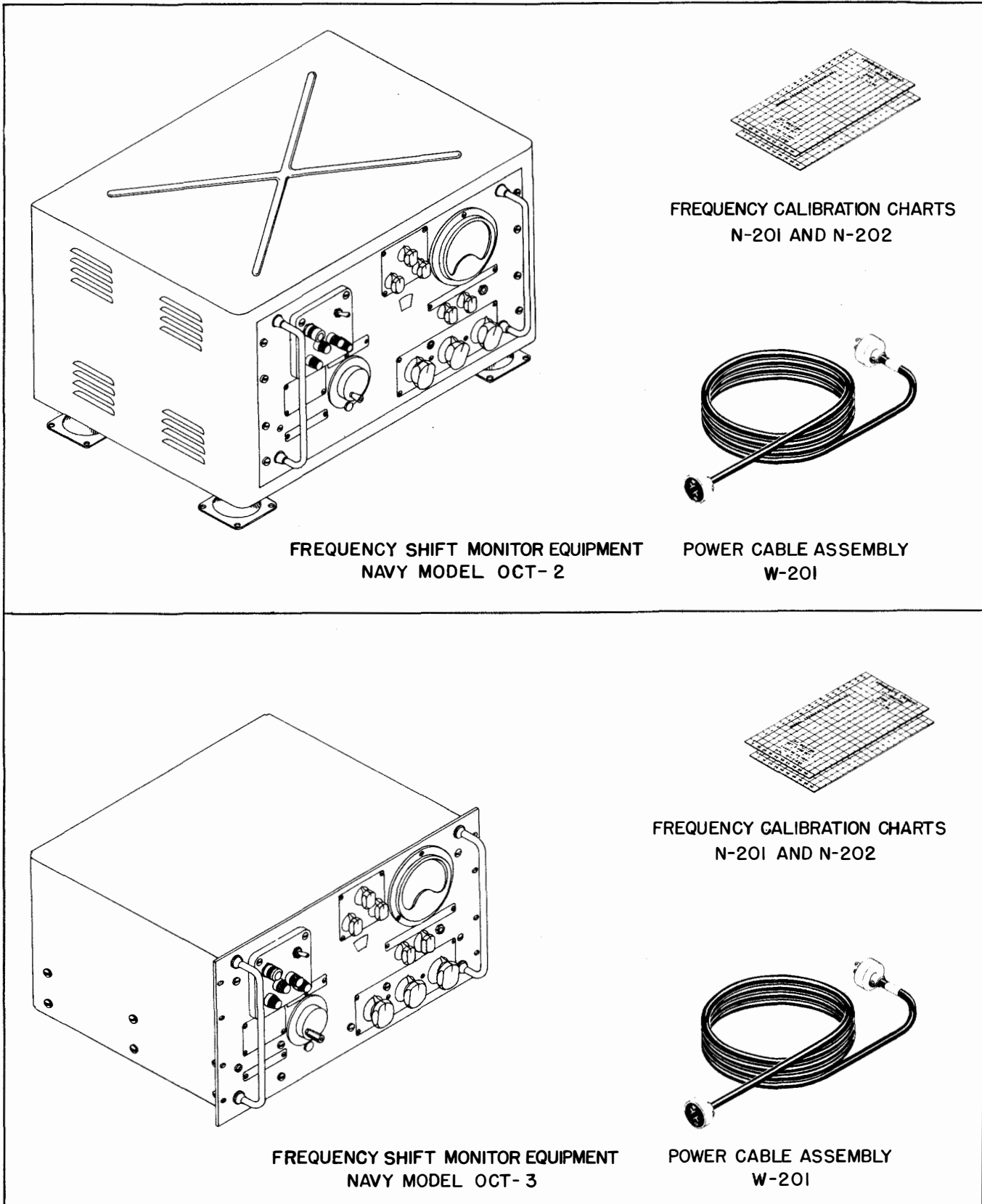

FREQUENCY SHIFT MONITOR EQUIPMENT
NAVY MODEL OCT- 2

FREQUENCY CALIBRATION CHARTS
N-201 AND N-202

POWER CABLE ASSEMBLY
W-201

FREQUENCY SHIFT MONITOR EQUIPMENT
NAVY MODEL OCT- 3

FREQUENCY CALIBRATION CHARTS
N-201 AND N-202

POWER CABLE ASSEMBLY
W-201

Figure 1-1. Frequency Shift Monitor Equipment, Navy Models OCT-2 and OCT-3

SECTION 1 GENERAL DESCRIPTION

1. INTRODUCTION.

a. The Frequency Shift Monitor Equipment, Navy Models OCT-2 and OCT-3 are test equipments designed for use in measuring carrier-frequency shift of transmitters used in the frequency-shift telegraph system over the range of one to 26 megacycles. The present equipment measures the total frequency-shift from space to mark over the limits of zero to 1500 cps, and functions on keyed or unkeyed signals. Since it is not necessary to interrupt periods of traffic to manually measure the amount of frequency-shift being used at the transmitter by keying first to the space frequency and then to the mark frequency, the equipment may be used as a continuous frequency-shift monitor.

b. This instruction book provides information required for the installation, operation, and maintenance of Frequency Shift Monitor Equipment, Navy Models OCT-2 and OCT-3. These two equipments are identical except for differences in mounting methods and overall dimensions. Frequency Shift Monitor OCT-2 is intended for shipboard use and is supplied in a shock-mounted cabinet, while the Frequency Shift Monitor OCT-3 is designed for rack-and-panel mounting in shore-type installations. The RF Monitor, comprised of the panel and chassis is the major unit of both the OCT-2 and OCT-3 equipments, and is completely interchangeable in either model. Throughout this handbook unless specific reference is made to either the OCT-2 or OCT-3 equipments, all information applies equally well to both models.

c. The present frequency-shift telegraph system uses several circuits not normally used in the usual form of amplitude modulated or "on-off" telegraph circuits. A description of the frequency-shift telegraph system is presented as an Appendix to Section 2 "Theory of Operation". Personnel should be familiar with the technical features of the frequency-shift telegraph system in order to understand the role that the present monitoring equipment plays in obtaining and maintaining the proper operation of the system.

2. FREQUENCY SHIFT MONITOR EQUIPMENT, NAVY MODELS OCT-2 AND OCT-3.

(See figures 1-1 through 1-4.)

a. The Frequency Shift Monitors OCT-2 and OCT-3 are identical except for differences in mounting and dimensions. RF Monitor is the major unit of both the OCT-2 and OCT-3 equipments, and thus the panel and chassis of the two equipments are completely

interchangeable and perform identical functions. The Frequency Shift Monitor OCT-2 is designed for shipboard use and is supplied in a shock-mounted cabinet as shown in figures 1-1 and 1-3. Frequency Shift Monitor OCT-3 is shown in figures 1-1 and 1-4, and is normally supplied with dust cover wrap-arounds which are in no way connected with the mounting of the equipment. The wrap-around fits inside the rack in which the equipment mounts. The dust cover also provides additional filtering for the monitor.

b. As shown in figure 1-2, the present equipment consists basically of a superheterodyne receiver with two cascade-connected limiters and a frequency-modulation detector or discriminator whose output is rectified and applied to a vacuum-tube-voltmeter. The a-c output of the discriminator is proportional to frequency-shift, and the vacuum-tube-voltmeter indicates the amount of frequency-shift in use at the transmitter. A unique feature of the present equipment is that the frequency-shift may be monitored continuously as well as by the space and mark difference-frequency method. The a-c output of the discriminator is a function of the amount of frequency-shift being employed in the transmitter.

c. Two self-contained crystals serve to calibrate the equipment and provide for accurate frequency-shift measurements. The calibrating crystals have 1000 cps frequency difference, and the monitor is adjusted for a reading of 1000 cps when these crystals are switched into the circuit. In addition, a very high order of frequency stability is maintained by operating the oscillator at a low frequency and using its harmonics for heterodyning with the incoming signal. A heat-insulated chamber houses the local oscillator to prevent temperature changes from affecting the accuracy of the calibration.

d. The equipment requires an external power source of either 115 or 230 volts a-c at any frequency of 50 to 60 cps, and consumes about 150 watts. Adequate protection is provided in case of overload by primary fuses. A primary voltage selector switch must be set to the voltage source used (either 115 or 230 volts a-c).

e. Installation methods are covered in Section 3 of this handbook, wherein the particular differences between Frequency Shift Monitors OCT-2 and OCT-3 are more apparent. The monitor equipment may be mounted in almost any convenient location so long as the frequency-shift indicating meter on the front panel is positioned for convenient reading.

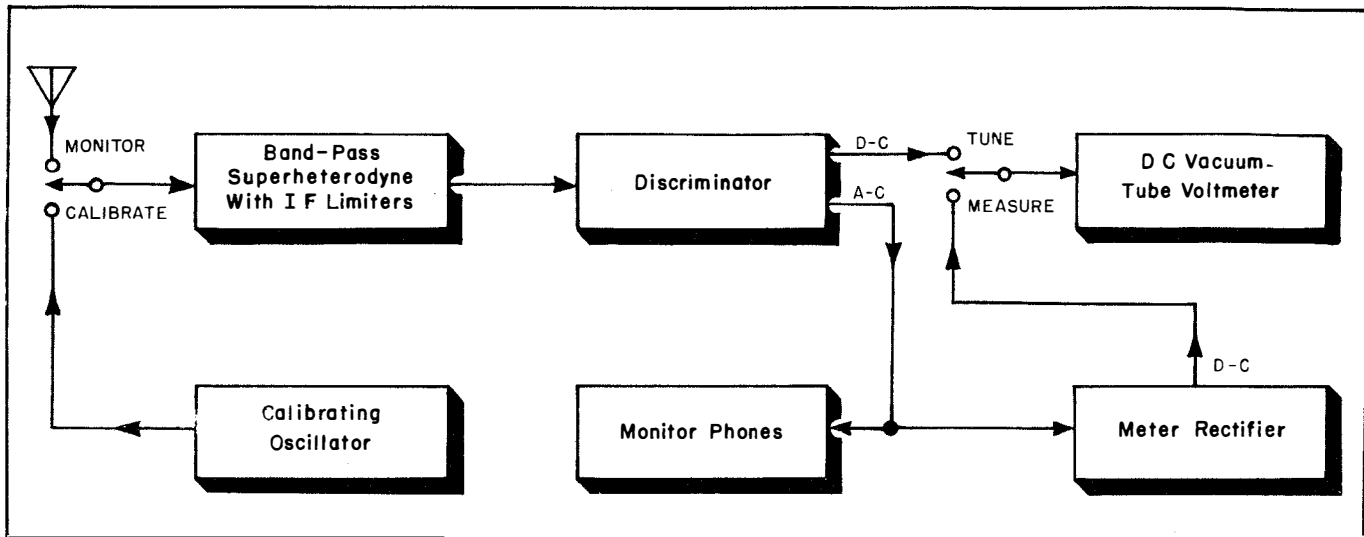

Figure 1-2. RF Monitor, Basic Block Diagram

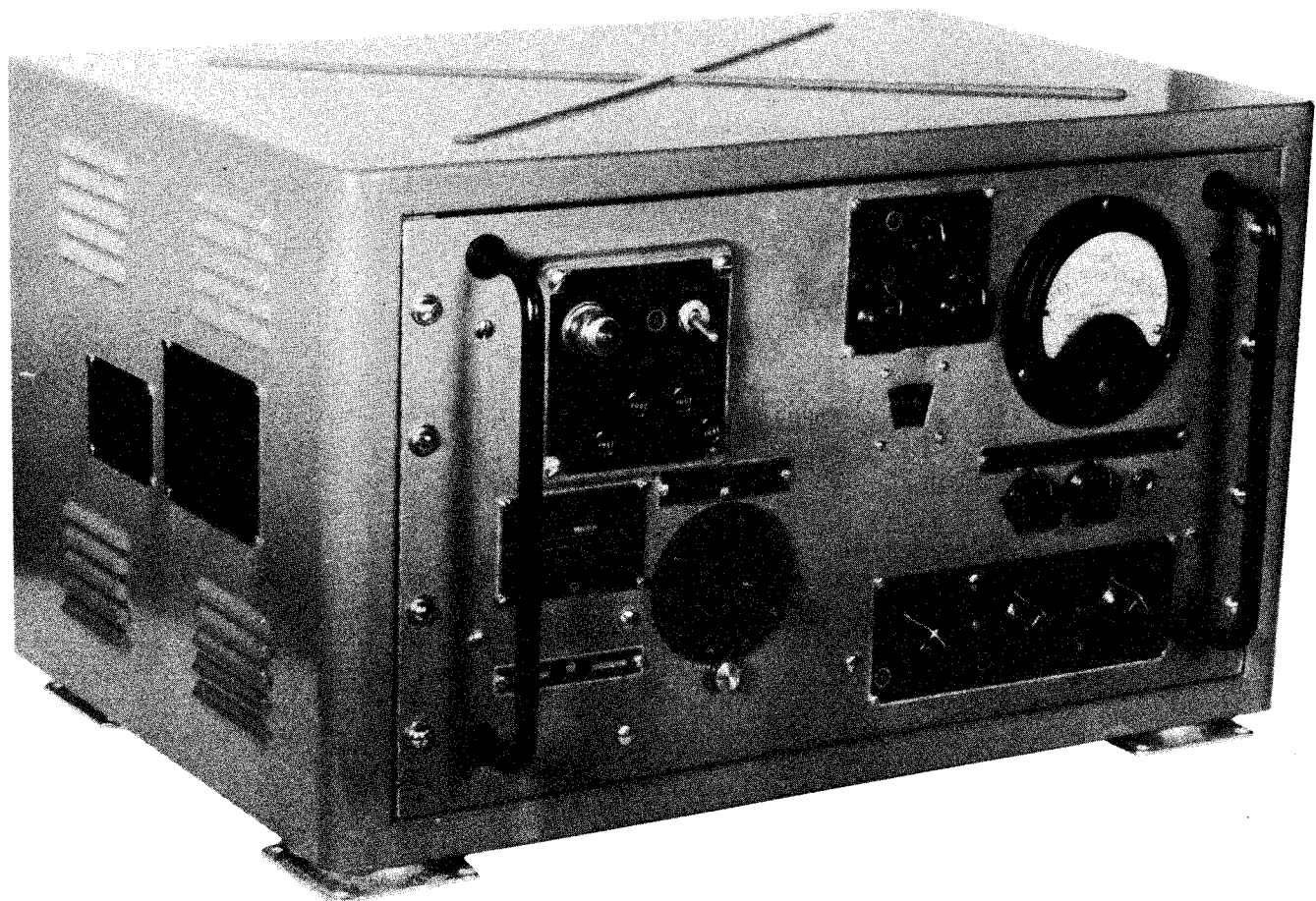

Figure 1-3. Frequency Shift Monitor OCT-2, Oblique View



Figure 1-4. Frequency Shift Monitor OCT-3, Oblique View

3. EQUIPMENT SUPPLIED.

The complete Frequency Shift Monitor Equipment, Navy Models OCT-2 and OCT-3 equipment supplied is listed in table 1-1 and illustrated in figure 1-1. For additional information refer to Section 8 of this instruction book, the complete Parts List.

TABLE 1-1. EQUIPMENT SUPPLIED

Quantity Per Equipment	Name of Unit	Navy Type Designation	Overall Dimensions			Volume	Weight
			Height	Width	Depth		
1	RF Monitor	-60170	10½	19	17	2.0	71
1	Cabinet*†	-10708	13⅞	21¾	17	2.8	34
1	Dust Cover‡	-10709	6⅛	17⅝	14⅞	1
1	Power Cord	-62450 (12' 0")	12' length including terminations			1½
2	Calibration Charts	8⅞	4⅝	1 oz.
4	Shock Mounts*	1½	3	3	0.08	15 oz.
1	Equipment Spare Parts Box	12¼	31⅞	16⅞	3.75	75
2	Instruction Books	NAVSHIPS 91131	11¼	8¾	½	0.03	9 oz.

*Supplied only with OCT-2 equipments.
†Dimensions and weight include shock mounts.
‡Supplied only with OCT-3 equipments.

Unless otherwise stated, dimensions are inches, volume cubic feet, weight pounds.

4. EQUIPMENT REQUIRED BUT NOT SUPPLIED.

All equipment normally necessary for the operation of RF Monitors OCT-2 and OCT-3 is supplied by the manufacturer. However, headphones having the characteristics listed in table 1-2, are desirable to provide aural monitoring of keyed frequency-shift signals. In addition, insufficient r-f pick-up from the transmitter would require additional coupling to the input of r-f monitor. Coaxial cable provides the most convenient method of coupling, and the coupling cable, which may or may not be required, is also listed in table 1-2.

5. SHIPPING DATA.

Table 1-3 contains an itemized shipping list of the equipment supplied, including equipment spare parts and the instruction book.

6. EQUIPMENT TUBE COMPLEMENT.

All electron tubes used in the equipment are listed by tube types and symbol designations in table 1-4.

7. INTERCHANGEABILITY OF MAJOR UNITS.

The panel and chassis (RF Monitor) of Frequency Shift Monitors OCT-2 and OCT-3 are completely interchangeable. The circuits of both equipments are identical. The units of the equipment that are different are identified by means of separate groups of symbol numbers. For example, the 300 series of symbol numbers relates specifically to Frequency Shift Monitor OCT-2, while the 400 series of numbers pertains to units of the Frequency Shift Monitor OCT-3 equipment. The 100 and 200 series of symbol numbers are

assigned to the major portion of the equipment and to the accessories that are common to the both equipments.

TABLE 1-2. EQUIPMENT REQUIRED BUT NOT SUPPLIED.

Quantity per Equipment	Name of Unit	Use	Required Characteristics
1	Headphones	Aural tuning indication	Impedance approx. 600 to 2000 ohms; with phone plug.
	Length of coaxial r-f transmission cable	R-f input cable	Characteristic impedance 50 to 75 ohms; length as required; type "UHF" male connector at RF Monitor end, other end loosely coupled to frequency shift transmitter under test

TABLE 1-3. SHIPPING DATA

Shipping Box No.	Contents	Overall Dimensions			Volume	Weight
		Height	Width	Depth		
1 of 1	Frequency Shift Monitor Equipment, Navy Model OCT-2 (shock-mounted cabinet).	15½	23½	32	6.75	179
1 of 1	Frequency Shift Monitor Equipment, Navy Model OCT-3 (dust cover wrap-around).	15½	23½	32	6.75	151
1 of 1	Equipment Spare Parts.	14¼	35 ⁹ / ₁₆	18 ¹¹ / ₁₆	5.49	115

Unless otherwise stated, dimensions are inches, volume cubic feet, weight pounds.

TABLE 1-4. ELECTRON TUBE COMPLEMENT

Tube Type	Application	Quantity	Reference Numbers
5Y3GT/G	Full-wave vacuum rectifier	1	V-112
6AL5	Twin diode	2	V-105, V-107
6AH6	Beam-power amplifier	1	V-110
6AV6	R-f amplifier pentode	3	V-103, V-104, V-109
6BA6	Remote cut-off r-f amplifier	1	V-102
6BE6	Pentagrid converter	1	V-101
6J6	Duo-triode	1	V-108
12AX7	Twin triode	1	V-106
OC3/VR-105	Glow discharge voltage regulator	1	V-111
Amperite 10-4D	Series ballast current regulator	1	V-113

8. REFERENCE DATA.

- | | | | |
|---|--|---|--|
| <p>a. Nomenclature.....</p> | <p>Frequency Shift Monitor Equipment, Navy Models OCT-2 and OCT-3.</p> | <p>m. Manner of deviation indication.....</p> | <p>Frequency-shift meter calibrated directly from zero to 1500 cps. Meter also indicates receiver output for initial equipment tuning.</p> |
| <p>b. Contract number and date.....</p> | <p>NObsr-42028, dated 8 October, 1947</p> | <p>n. Type of reception...</p> | <p>Equipment designed to monitor frequency shift transmissions up to 1500 cps.</p> |
| <p>c. Contractor.....</p> | <p>Hazeltine Electronics Corp.
Little Neck, New York</p> | <p>o. Self-calibration.....</p> | <p>Two crystal-controlled self-calibrating frequencies adjusted for 1000 cycles per second frequency-difference at approximately 1.0 Mc mean frequency. Special dual crystal unit employed.</p> |
| <p>d. Cognizant Naval Inspector.....</p> | <p>Inspector of Naval Material, USN,
New York, N. Y.</p> | <p>p. Frequency stability..</p> | <p>Maximum frequency drift approximately 0.5 cycles per megacycle per minute for constant ambient temperature after approximately one-hour warm-up period. Approximately 1.0 cycles per megacycle per minute for constant ambient temperature after ten minute warm-up period.</p> |
| <p>e. Number of packages involved per complete shipment, including equipment spares</p> | <p>OCT-2 2
OCT-3 2</p> | <p>q. Input impedance</p> | <p>Approximately 75 ohms.</p> |
| <p>f. Total cubical contents (equipment spares included)</p> | <p>OCT-2 (crated) ... 12.25 cu. ft.
OCT-2 (uncrated) . 5.92 cu. ft.
OCT-3 (crated) ... 12.25 cu. ft.
OCT-3 (uncrated) . 5.12 cu. ft.</p> | <p>r. Primary power supply requirement.....</p> | <p>115 or 230 volts, 60 cycles per second, single phase, a-c.</p> |
| <p>g. Total weight (equipment spares included)</p> | <p>OCT-2 (crated) ... 288 lbs.
OCT-2 (uncrated) . 180 lbs.
OCT-3 (crated) ... 261 lbs.
OCT-3 (uncrated) . 147 lbs.</p> | <p>s. Power consumption of equipment.....</p> | <p>Approximately 85 volt-amperes at nominal a-c line voltage.</p> |
| <p>h. Frequency range</p> | <p>1.0 to 26 Mc in four ranges</p> | <p>t. Accuracy of measurement.....</p> | <p>± 5% over operating range of 300 to 1400 cps.</p> |
| <p>i. Number of tuning bands and range of each band.....</p> | <p>Four tuning bands:
1.0 to 2.9 Mc
2.9 to 6.7 Mc
6.7 to 14 Mc
14 to 26 Mc</p> | <p>u. Crystal calibration accuracy.....</p> | <p>± 20 cps over -15°C to +50°C temperature range.</p> |
| <p>j. Type of tuning.....</p> | <p>Manual tuning dial with frequency calibration charts.</p> | <p>v. Minimum keying speed.....</p> | <p>20 cps or 40 wpm. Degredation of accuracy gradual below this minimum. Unequal space-to-mark ratios have no effect on the accuracy of signals composed of dots, dashes, and spaces of normal length.</p> |
| <p>k. Type of receiver.....</p> | <p>Frequency-modulation superheterodyne.</p> | <p>w. R-f signal input level.</p> | <p>15 millivolts to 20 volts.</p> |
| <p>l. Intermediate Frequency.....</p> | <p>912 kilocycles.</p> | | |

SECTION 2

THEORY OF OPERATION

1. SCOPE AND CONTENTS.

a. Section 1 of this handbook described the general features of the Frequency Shift Monitors OCT-2 and OCT-3. The present section describes in more detail the mechanical functioning and the electrical theory of operation of this equipment, with particular emphasis on circuit and other features not normally encountered in equipments of this type. In addition, a description of the characteristics and technical features of the frequency-shift telegraph system is presented at the end of this section.

b. Except for differences in mechanical details (important only with regard to installation mounting methods) the two equipments are identical, and no differentiation between the two equipments will be made in this section.

c. Frequency Shift Monitors OCT-2 and OCT-3 permit the continuous monitoring of the space-to-mark frequency deviation of any frequency-shift transmitter using up to 1500 cycles per second frequency-shift. Frequency-shift is indicated directly on a panel meter calibrated in cycles per second. The present equipment is operative over a range of one to 26 megacycles.

d. The block diagram of figure 2-1 and the schematic diagram of figure 7-6 should be referred to for assistance in gaining a thorough understanding of the functional details of the equipment. In addition, several sectionalized block and schematic diagrams of portions of the equipment are included in this section as an aid to more complete coverage of certain circuit functions.

2. THE MAIN SIGNAL PATH.

(See figure 2-1.)

a. As shown in the equipment block diagram of figure 2-1, the main signal path commences at input jack J-101 and proceeds through the band-switched tuned input circuit to the input of a conventional superheterodyne mixer. A highly stable local oscillator drives a frequency multiplier, the harmonic output of which combines with the r-f input in the mixer to produce a 912-kc intermediate-frequency signal, with the oscillator operating on the high-frequency side of the signal frequency. This i-f signal is amplified by the stage of i-f amplification and then limited by two cascade-connected limiter stages, and is applied to a linear frequency modulation discriminator. The a-c

output of this discriminator, corresponding to the variations in frequency of the frequency-shift keyer, is rectified by a peak-to-peak meter rectifier and applied to a d-c vacuum-tube voltmeter. The indication on the meter is proportional to the peak-to-peak a-c voltage of the discriminator, so that the meter is calibrated directly in cycles per second frequency shift.

b. Preliminary calibration of the equipment is necessary to insure reliable frequency-shift indication. To accomplish this preliminary calibration, a calibrating oscillator capable of producing two frequencies separated by 1000 cycles per second is incorporated in the equipment. The lower of these frequencies, Freq. A, in figure 2-1, corresponds to the space frequency of a frequency-shift keyer, and the higher, Freq. B, corresponds to the mark frequency. Thus, the calibrating oscillator serves as a reference frequency-shift keyer whose space-to-mark (Freq. A to Freq. B) frequency deviation is constant and known. A preliminary calibration procedure for the equipment is given in Sections 4 and 5, covering the operation of the equipment.

c. For initial tuning of the equipment, provision has been made for aural as well as visual signal indication. As can be seen in figure 2-1, with the D TUNE-MEASURE switch in the TUNE position, the a-c output of the discriminator, isolated by the buffer amplifier, is applied to the monitor headphones, and the d-c voltage is applied through the meter amplifier to the meter.

3. INPUT TUNING.

a. From INPUT jack J-101, the signal to be monitored is applied through the contacts of the C MONITOR-CALIBRATE switch to the band-switched input tuning circuit, which consists of four r-f coils, any one of which may be selected as the input tuning coil, depending upon the frequency of the signal to be monitored.

b. The input tuning signal-frequency range of from 1.0 to 26 megacycles is covered in four bands: 1.0 to 2.9, 2.9 to 6.7, 6.7 to 14, and 14 to 26 megacycles. For stability, the frequency coverage of each band was chosen so as to allow the use of a single local oscillator frequency range for all bands, utilizing the local oscillator fundamental frequency for the lowest band and appropriate harmonic frequencies for the remainder of the bands.

c. The input tuning capacitor C-105 is ganged with the local oscillator tuning capacitor C-160 for simplicity of operation, but, for the reason outlined above,

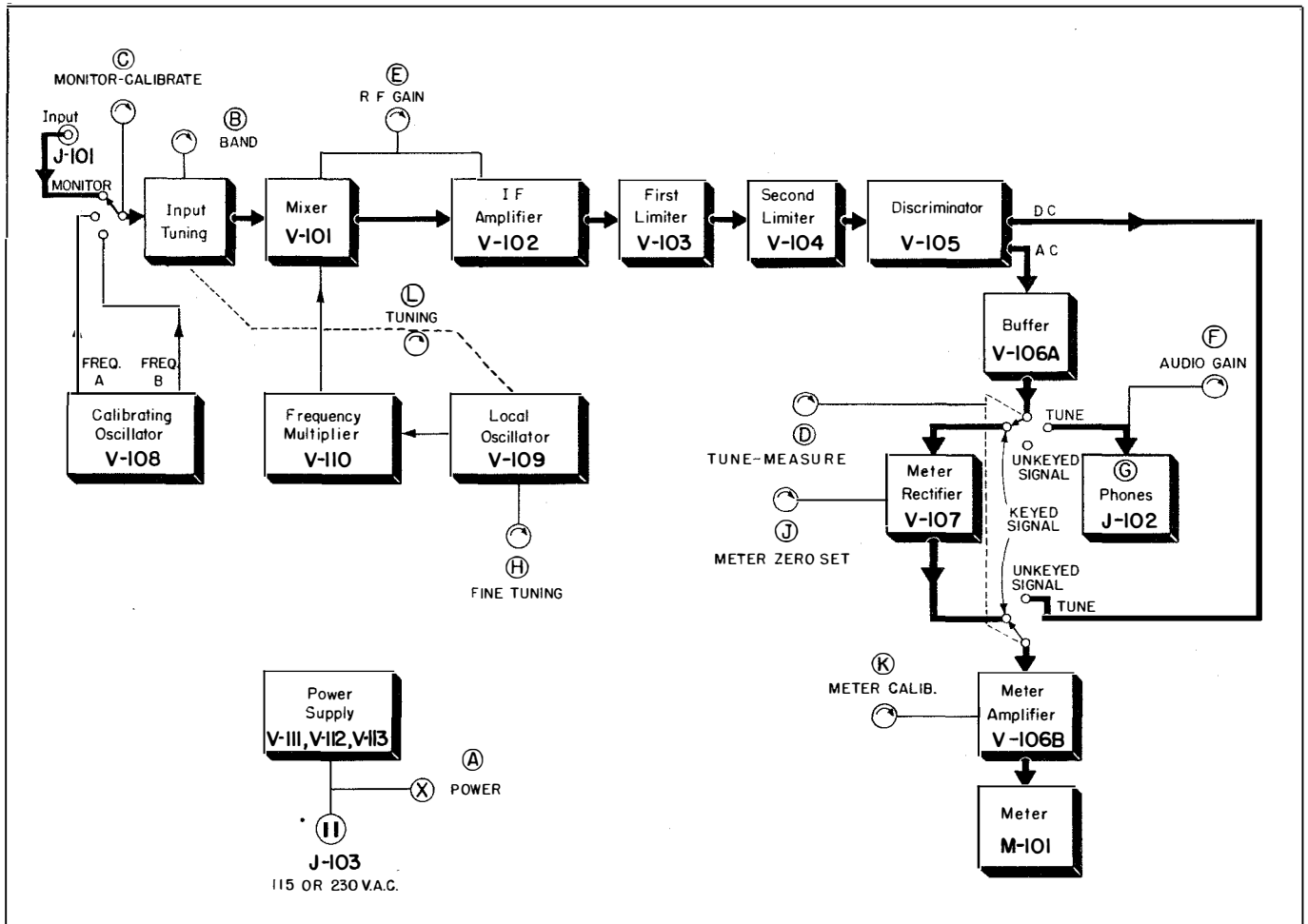

Figure 2-1. RF Monitor, Block Diagram

only the input tuning coils are band-switched. From the input tuning circuit the signal is applied to the mixer, where it is combined with the fundamental or a harmonic of the local oscillator frequency to produce the intermediate frequency.

4. THE LOCAL OSCILLATOR AND FREQUENCY MULTIPLIER.

a. The local oscillator V-109, an electron-coupled Hartley type, drives frequency multiplier V-110, and the harmonic-rich output of the local oscillator frequency is applied to the injection grid of the mixer, where the fundamental or harmonic frequency heterodynes with the incoming signal to produce the intermediate frequency of 912 kc.

b. In order to achieve the unusually high frequency-stability required in this type of application, the local oscillator frequency-determining coil and variable capacitor are enclosed within an exceptionally well heat-insulated housing. This housing mini-

mizes the effects of fluctuations in the ambient temperature on the oscillator constants. In addition, the connections to the local oscillator tube are tapped down on the oscillator coil to reduce the effect of changes in tube loading on the frequency stability.

c. The fundamental tuning ratio of the local oscillator is approximately 1.84 to 3.8 megacycles. Over this range, the local oscillator tuning capacitor exhibits a substantially straight-line-frequency characteristic, and the frequency change in kilocycles is proportional to the angle of rotation of the tuning capacitor. This is of advantage when a single local oscillator range is to be used in a multi-band superheterodyne, since by utilizing a similar straight-line-frequency tuning characteristic in the signal-frequency circuits no special tracking problems are encountered, even when harmonics of the local oscillator frequency are used.

d. The plate circuit of the local oscillator is untuned to prevent attenuation of the harmonic content in its output, which is capacitively coupled to the frequency

multiplier. The plate circuit of frequency multiplier V-110 is also untuned, and contains simply a small value of inductance of 1.5 micro-henries. Thus, the impedance of the plate load is proportional to frequency, resulting in a spectrum response proportional to the order of the harmonic considered. The result is that at the output of the frequency multiplier the fundamental and harmonics of the local oscillator frequency are all approximately of the same order of magnitude, so that the conversion efficiency of the mixer remains essentially constant regardless of the order of the local oscillator harmonic with which the desired signal is heterodyned.

e. In the present equipment, local oscillator harmonics up to the eighth are used. The local oscillator fundamental frequency is used for the 1.0 to 2.9 megacycle band; its second harmonic for the 2.9 to 6.7 megacycle band; its fourth harmonic for the 6.7 to 14 megacycle band; and its eighth harmonic for the 14 to 26 megacycle band. Actually, the fundamental and all harmonics of the local oscillator frequency are simultaneously present at the mixer, but since the r-f input circuit is tuned, no spurious responses are encountered through interaction. The 912-kc intermediate frequency is high enough to assure adequate image-frequency rejection on the highest frequency band, and is low enough to provide the necessary stability of amplification.

5. THE MIXER AND I-F AMPLIFIER.

a. The function of the mixer, as in conventional superheterodyne receivers, is to modulate the signal frequency with the local oscillator frequency (or one of its harmonics) to produce an intermediate-frequency signal of 912 kilocycles which is coupled by means of a tuned i-f transformer to the 6BA6 i-f amplifier tube V-102. After this one stage of i-f amplification, the signal is applied to two cascaded limiter stages V-103 and V-104 and then to discriminator V-105.

b. Manual r-f gain control is accomplished by varying the cathode bias on the mixer and i-f amplifier. The screen grid potentials for these tubes are obtained through voltage-dropping resistors from the high-voltage plate supply. This increases both the linearity and the range of gain control by enhancing the super-control (remote cut-off) characteristic of the tubes; because as the tube bias is increased toward plate- and screen-current cut-off the screen-grid voltage rises and tends to oppose the reduction in plate current.

6. THE I-F LIMITERS.

a. Two cascaded limiters are employed in the present equipment in order to maintain the i-f signal applied to the discriminator at a constant amplitude, since the output of the discriminator is directly proportional to the amplitude of its frequency-shift input signal. Effective amplitude limiting is particularly important in the case of the present equipment, where precise measurements of frequency shift are required, since for a given frequency shift, the discriminator must produce a constant output, regardless of the amplitude of the input signal.

b. The i-f limiters are of the grid-leak-bias type, wherein the tube grid bias is developed by the flow of grid current through a moderately high-resistance grid leak. The negative grid bias thus produced is directly proportional to input signal amplitude, so that the gain of each limiter varies approximately as the inverse of input signal amplitude. The small residual variations in amplitude at the output of the first limiter V-103 are removed by the second limiter V-104, and highly effective overall limiting is accomplished. The limiters take effect at some relatively low level of input signal amplitude, called the limiting threshold, and for all values above this level the output of the limiters, applied to the discriminator, is substantially constant.

c. The screen grid voltage of the second limiter V-104 is made adjustable by means of the limiter output potentiometer R-120 to control the gain and adjust the output level of this stage. The adjustment of this potentiometer is covered in the internal servicing adjustment procedures, and should be performed in accordance with the method outlined in table 7-3 in Section 7 of this handbook.

7. THE DISCRIMINATOR.

a. The discriminator circuit used in the present equipment, as can be seen from examination of the equipment schematic circuit diagram of figure 7-6, is of conventional type. This type of discriminator circuit has the advantage that its dynamic characteristics do not appreciably differ from its static characteristics. Thus, for the purposes of the present equipment, its sensitivity is entirely independent of frequency-shift keying speeds, even down to zero keying speed.

b. The high-resistance discriminator load (R-125 and R-126) keeps the efficiency of rectification of the two diodes of discriminator V-105 at a high level, and adds to the overall discriminator linearity, since the internal impedance of the diodes never exceeds a few percent of the load resistance, even at the lowest r-f input signal levels normally encountered.

8. THE INDICATOR CIRCUITS.

(See figures 2-1, 2-2, 2-3 and 2-4.)

a. The indicator circuits, consisting of the phone and meter circuits, are here treated as a group, functionally related through three inter-dependent functions: aural and visual indication during initial self-calibration, during preliminary tuning, and during actual monitoring. Aural indication is used only during preliminary tuning of the equipment, and is effective only when the equipment is being tuned to a frequency-shift transmitter being operated at a moderately high (within the audible range) keying speed.

b. These circuits are comprised of the isolating buffer amplifier V-106A, phone jack J-102, twin-diode meter rectifier V-107, cathode-follower meter amplifier V-106B, and the indicating meter M-101, the various functions of which are controlled by a three-position selector, TUNE-MEASURE switch S-130. The simplified schematic circuit diagrams of figures 2-2, 2-3 and 2-4 represent the essential indicator circuitry for each respective position of this switch, while the equipment block diagram of figure 2-1 illustrates the basic functioning of the indicator circuits.

c. The functioning of the indicator circuits will, for purposes of circuit analysis, be differentiated into three conditions corresponding to the three positions of TUNE-MEASURE switch S-130: TUNE, UNKEYED SIGNAL, and KEYED SIGNAL. The TUNE position is used for initial tuning of the equipment to the frequency-shift signal to be monitored, when the d-c output of the discriminator is indicated on the meter, and the a-c discriminator output (if the signal is frequency-modulated, or keyed) is applied to the phones, and is audible as keying transients or clicks as the transmitter frequency abruptly shifts from one frequency to the other during keying. In this position the characteristic discriminator "S" curve is a function of tuning and may be obtained over the meter face, because an internal meter bias current is applied which alters the apparent meter zero to approximately mid-scale. The UNKEYED SIGNAL position is used for fine tuning, when the tuning bias is removed and the phones disconnected. Here the d-c output of the discriminator is indicated on the meter, and the zero cross-over point of the characteristic discriminator "S" curve may be tuned to the meter zero, even though the signal be frequency-modulated (keyed). The KEYED SIGNAL position is used only for actual monitoring of a frequency-modulated (keyed) signal, when the a-c voltage output of the discriminator, representing the frequency variations of the signal, is rectified, and the resultant d-c voltage (proportional to the peak-to-peak frequency-shift of the applied signal) indicated on the meter.

9. INDICATOR CIRCUITS — TUNE OPERATION.

(See figure 2-2.)

a. When TUNE-MEASURE switch S-130 is in the TUNE position, the indicator circuits are connected so as to provide aural and visual tuning indication for the initial tuning of the equipment to the frequency-shift signal to be monitored. In this position of switch S-130, only the buffer V-106A, meter amplifier V-107, phone jack J-101, and the meter M-101 are operative in the indicator circuits. Figure 2-2 shows the block diagram and the schematic diagram of the indicator circuits for this condition. Here the output of the discriminator V-105 is applied both to the buffer V-106A and to the meter amplifier V-106B. From the buffer, the a-c voltage corresponding to the modulation component of the signal is applied through phone jack J-102 to the headphones, if used. The d-c component of the discriminator output, from the meter amplifier, is indicated on meter M-101. A tuning bias is applied to the meter circuit to bring the apparent meter zero to mid-scale, so that the characteristic discriminator "S" curve which as a function of tuning will be visible over the meter face.

b. The output of the discriminator is applied across the divider network comprised of resistors R-123, R-128, R-142 and R-143. Resistor R-123, in combination with distributed circuit shunt capacitances, acts as an additional r-f filter at the output of the discriminator. Its value of 100,000 ohms is small compared with the values of R-128, R-142, and R-143, so that it produces no appreciable loss in discriminator output. The discriminator is the unbalanced version, wherein one of the cathodes of the discriminator is grounded, or bypassed to ground for audio frequencies. In this case, one cathode of discriminator V-105 is bypassed to ground through C-127, and the entire discriminator circuit is given a positive bias from the tap arm of potentiometer R-135, part of a power-supply voltage-divider network. This positive bias is effective at the grids of the buffer and the meter amplifier, so that relatively high values of cathode load resistance may be used in both tubes for increased stability and greater signal-handling capability. The actual value of this bias is critical when the indicator circuits are operating under "unkeyed signal" conditions as determined by the setting of TUNE-MEASURE switch S-130. The discriminator output is applied through R-123 to the grid of buffer V-106A. The cathode output is coupled through capacitor C-130 to the phone circuit. AUDIO GAIN control R-130 is placed in series with the phone jack to control the headphone volume over a range of six to 20 db, so that full volume is available when required, but sufficient volume is maintained at all times to prevent the possibility of incorrect indication

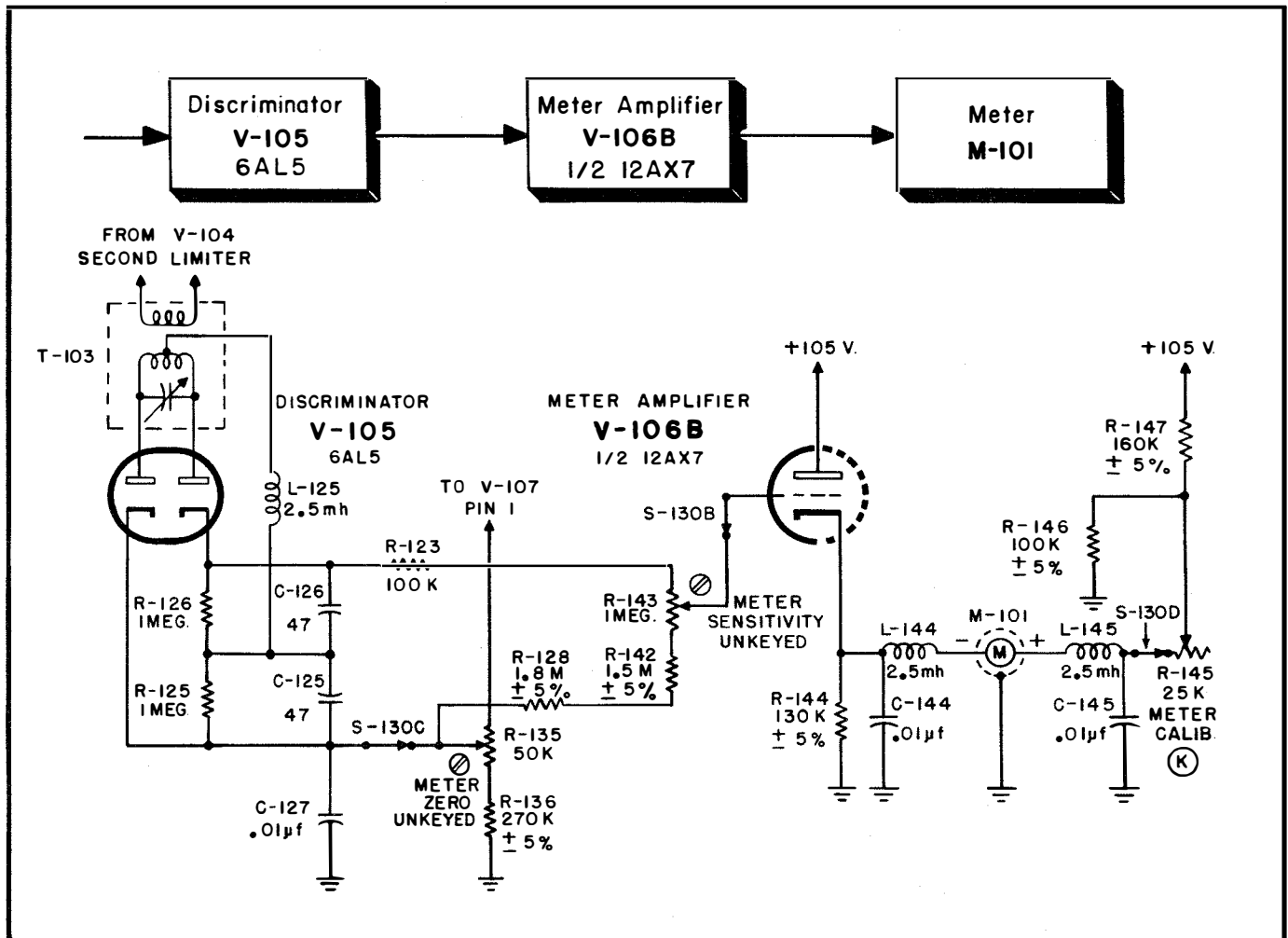

Figure 2-3. Indicator Circuits, Unkeyed Operation

flows through the meter, and the operating point of V-106B is determined solely by the value of R-144. In this case, a high value of resistance for R-144 is indicated as effecting a desirable operating point. The line of compromise between the two conflicting requirements is rather sharp, and rests in the region between 120,000 and 140,000 ohms, with 130,000 ohms representing a suitable compromise.

10. INDICATOR CIRCUITS — UNKEYED SIGNAL OPERATION.

(See figure 2-3.)

a. When TUNE-MEASURE switch S-130 is in the UNKEYED SIGNAL position, the indicator circuits are connected so that the d-c component of the discriminator output is indicated on the meter to aid in accurate tuning of the equipment to the signal to be monitored. In this position of switch S-130, only the meter amplifier and the meter are operative in the

indicator circuits. The simplified block diagram and the equivalent schematic diagram of figure 2-3 show the connections of the indicator circuits for this condition of operation. Here the output of the discriminator is applied to meter amplifier V-106B, and from the meter amplifier to meter M-101, where the d-c component of the discriminator output is indicated on the meter. In this case, zero d-c component in the discriminator output, corresponding to exact tuning to the signal to be monitored, appears as a true zero reading on the meter. In addition, the sensitivity of the meter in this condition of operation is greatly increased over that in "tune" operation, so that fine tuning of the equipment to a frequency-shift signal to be monitored is accomplished by adjusting the FINE TUNING potentiometer R-165.

b. The meter circuit is here arranged in the form of a bridge, with the meter amplifier tube and its cathode load resistor R-144 forming one pair of arms

and the voltage-divider network consisting of resistors R-146 and R-147 forming the other, with the meter connected to act as a balance indicator. The conduction of the meter amplifier, which is dependent upon the effective voltage at its grid, controls the balance of this bridge. In the absence of signal, or when the equipment is exactly tuned to the applied signal (zero d-c component in the output of the discriminator) the conduction of the meter amplifier depends upon the positive d-c bias voltage at the tap arm of potentiometer R-135 (meter zero unkeyed). The adjustment of this potentiometer is a servicing procedure, and it must not be changed during operation of the equipment, since it is adjusted during servicing to bring the meter bridge circuit to exact balance with no d-c discriminator output. During operation, the meter bridge circuit is brought into balance by varying the tuning of the equipment, with balance (zero reading on the meter) indicating exact tuning or zero d-c component in the output of the discriminator. Signal frequencies higher than that to which the equipment is then tuned will cause the meter reading to increase toward full-scale, while lower signal frequencies will cause the meter to read off-scale in the negative direction. The portion of discriminator output appearing across the signal divider network between the dynamically grounded side of the discriminator and the tap arm of potentiometer R-143 (meter sensitivity unkeyed) is applied to the grid of the meter amplifier. The d-c component of the discriminator output is then indicated on the meter as an unbalance current in the meter bridge. Only the d-c component of the discriminator output is effective at the meter, since any a-c component present will normally have too high a frequency for the meter to follow. The adjustment of potentiometer R-143 is a servicing adjustment which brings the meter reading for UNKEYED SIGNAL operation, for a given static frequency change, into coincidence with the meter reading in the KEYED SIGNAL position with the same frequency change (measured dynamically, as a keyed frequency deviation). This adjustment should not be changed or altered during operation, and is to be adjusted only by qualified personnel in accordance with the equipment alignment procedures specified in Section 7 of this handbook.

c. During initial self-calibration of the equipment, it may be found that the meter does not indicate a frequency difference of 1000 cycles per second after the equipment is tuned to CALIB. FREQ. A with switch S-130 in the UNKEYED SIGNAL position and then CALIB. FREQ. B is switched on. For this reason the METER CALIB. variable resistor R-145 is provided to adjust the meter current flowing when the meter circuit is unbalanced by a signal frequency different from that

to which the equipment is tuned. Changing the meter current changes the meter reading, and the meter can be made to indicate 1000 cps frequency-shift during the self-calibration procedure, after which the meter reading can be depended upon for accuracy when the actual frequency-shift measurement is made. The preliminary equipment self-calibration procedure is outlined in Sections 4 and 5 of this handbook.

11. INDICATOR CIRCUITS — KEYED SIGNAL OPERATION.

(See figure 2-4.)

a. When the TUNE-MEASURE switch S-130 is in the KEYED SIGNAL position, the indicator circuits are connected so that the a-c component of the discriminator output is rectified, and the resultant d-c voltage, directly proportional to the peak frequency deviations of the frequency-shift transmission being monitored, is indicated on the meter. In this position of switch S-130, the buffer V-106A, the meter rectifier V-107, the meter amplifier V-106B and the meter M-101 are operative in the indicator circuits. The simplified block diagram, together with its corresponding simplified schematic diagram of figure 2-4 show the connections of the indicator circuits for this condition of operation. Here the output of the discriminator, from the buffer, is applied to the meter rectifier, where its a-c component is rectified and applied through the meter amplifier to the meter.

b. The entire discriminator output is applied to the grid of the buffer (neglecting the signal loss caused by resistor R-123), from the cathode of which it is capacitively coupled through C-130 to the meter rectifier. The meter rectifier is arranged as a peak-to-peak rectifier, and the resistance-capacitance time-constants of its input and load circuits are made long enough to assure constant response down to very low frequencies, so that the meter indication may be depended upon for accuracy even at the lowest frequency-shift keying speeds normally to be encountered. The meter amplifier and meter circuits remain the same as for the UNKEYED SIGNAL position of the TUNE-MEASURE switch, except that now the d-c output of the meter rectifier is indicated on the meter as the measure of frequency-shift of the signal being monitored.

c. The load resistor R-133 for the meter rectifier has a sufficiently high resistance value to introduce contact-potential difficulties in the diodes of V-107. To minimize erroneous indications on the meter because of such contact-potential, the diodes of V-107 are biased so that a small constant diode current is allowed to flow at all times. The voltage across resistor R-132, part of a voltage-dividing network consisting of resistor R-136 and potentiometer R-135 (meter

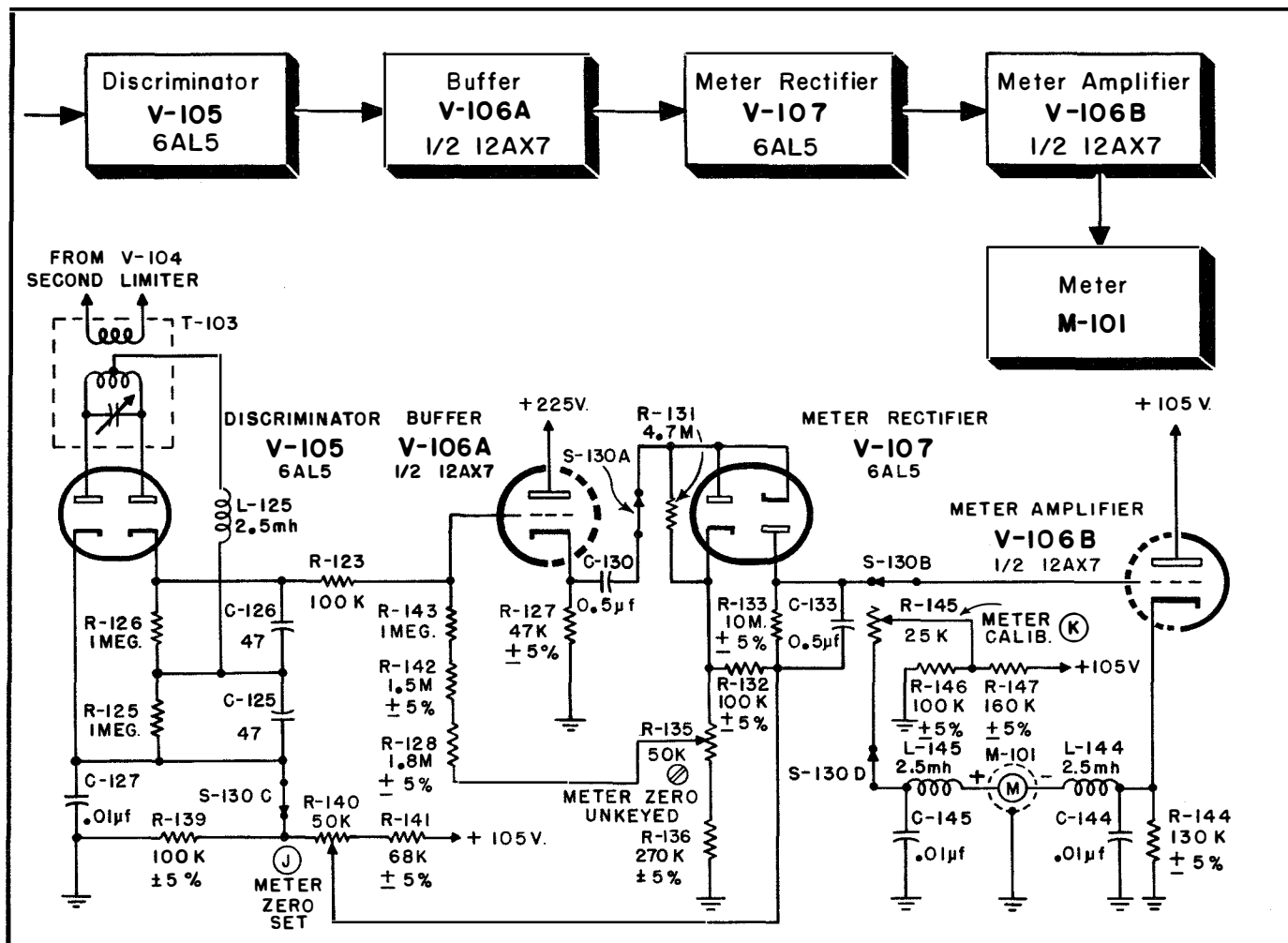

Figure 2-4. Indicator Circuits, Keyed Operation

zero unkeyed), is used to produce this diode current. However, since the value of resistor R-133 is so high, the biasing voltage across R-132 cannot completely overcome the contact-potential developed in the diodes of V-107. No benefit would result from increasing the voltage across R-132, since the linearity of rectification of V-107 would be adversely affected, even though the contact-potential troubles would be alleviated to a large extent. In order that the meter zero for the UNKEYED SIGNAL may coincide with the meter zero for the KEYED SIGNAL, means are provided to make the effective no-signal bias on the grid of the meter amplifier the same in both conditions, since the meter circuits do not change when switching from one method of operation to the other. This is accomplished by obtaining this grid bias from the arm of potentiometer R-135 (meter zero unkeyed) in the UNKEYED SIGNAL position of S-130, so that the contact-potential bias effective at the grid of the meter amplifier for the

KEYED SIGNAL position will be exactly balanced by the bias voltage at the arm of potentiometer R-135 in the UNKEYED SIGNAL condition.

12. THE CALIBRATING OSCILLATOR.

a. A crystal-controlled calibrating oscillator is included to permit initial self-calibration of the equipment immediately prior to the actual measurement or monitoring of the frequency-shift transmitter signal. This calibrating oscillator operates at each of two frequencies which are spaced 1000 cycles per second apart, the lower frequency corresponding to the space frequency, and the higher corresponding to the mark frequency of a frequency-shift keyer. The initial calibration procedure consists merely of accurately tuning the equipment to the lower of the two frequencies, then switching to the higher frequency and adjusting the METER CALIB. potentiometer R-145 until the meter indicates a frequency-shift of 1000 cycles per second.

b. The calibrating oscillator consists of two crystal-controlled aperiodic oscillators, either of which may be selected by MONITOR-CALIBRATE switch S-101. The contacts of this switch apply plate voltage to that section of the dual-triode calibrating oscillator which corresponds to the desired calibrating frequency, and also connect the output of the calibrating oscillator to the input tuning circuits of the mixer. The two frequency-determining crystals, with fundamental frequencies in the region of one megacycle, are chosen as a pair with their frequencies differing by precisely 1000 cycles per second, and are carefully selected to have matching temperature coefficients of frequency and equal activity. The crystals are then mounted and sealed in a dual crystal holder suitably inscribed with the fundamental frequency of each crystal. Since the actual fundamental frequencies of the crystals are immaterial, only the frequency difference between them being important, no tolerance rating is applicable as to fundamental frequency.

c. As shown in the equipment schematic circuit diagram of figure 7-6, calibrating oscillator V-108 has its grids connected together and returned to ground through biasing resistor R-155. Each plate of V-108 is coupled back to the grids through one of the frequency-determining crystals of Z-101 and blocking capacitors C-157 and C-158. Variable trimmer capacitors C-155 and C-156 are provided for vernier adjustment of the calibrating frequencies to correct for inaccuracies due to manufacturing tolerances in the crystals of Z-101. The output of the calibrating oscillator is taken from across a small portion of the plate load resistors of V-108 such that its amplitude is sufficiently attenuated that no overloading of the equipment occurs even with the R. F. GAIN control R-110 advanced to full gain. Regulated voltage (+105 volts) is applied to the calibrating oscillator to minimize frequency variations caused by fluctuating plate voltage.

13. THE POWER SUPPLY.

a. The power supply provides the required plate, screen-grid, and bias potentials, as well as a-c current for the heaters of the electron tubes. In the present equipment, two positive d-c potentials are available: 260 volts and 105 volts. The latter is well regulated and is obtained through the use of a current-limiting resistor and gaseous glow-discharge voltage regulator V-111.

b. A full-wave center-tapped rectifier circuit with a two-section inductance-capacitance filter supplies the positive 260-volts potential. A series current-limiting resistor drops this potential to 105 volts at the anode of the OC3/VR-105 glow-discharge voltage

regulator V-111 to provide a medium-voltage low-impedance source to the circuits requiring a well-regulated potential (the calibrating oscillator V-108, the local oscillator V-109, the limiters V-103 and V-104, the meter rectifier V-107, and the meter amplifier V-106B).

c. A grounded-center-tap 12.6-volt heater winding on the power transformer T-104 is used for all the electron tubes and pilot lamp, with the exception of the rectifier V-112. Four tube heaters are connected from one side of the heater winding to ground, three more and the pilot lamp are connected from the other side to ground, and the series current regulating ballast tube V-113 is placed in series with the three tubes which require a regulated heater supply (the local oscillator V-109, the buffer/meter amplifier V-106 and the meter rectifier V-107) across the full 12.6-volt winding. Since ballast tube V-113 is designed to regulate a current of one ampere, and the three tubes whose heater current is regulated require a total current of only 0.9 ampere, the three tube heaters are shunted by resistor R-181, the resistance value of which allows the difference current ampere to flow through it.

d. Such a system of parallel-connected heaters in series with a current-regulating ballast tube has the disadvantage that if one tube develops an open heater, the remainder of the tubes are subjected to the full current, and this may be sufficient to damage their heaters. In the present case, the total regulated current is one ampere. For the three tubes and the shunt resistor, the total resistance is approximately equal to six ohms when the heaters have reached their full temperature. Thus, the voltage across the combination is six volts. If one of the tubes were removed, or if one developed an open heater, the combination resistance would rise to approximately 8.3 ohms, corresponding to approximately 8.3 volts across the combination. No serious damage will occur in this case, provided that it is not allowed to continue for long periods of time, beyond the symptoms of improper equipment operation. This represents the worst possible case, since if the resistor were to burn out, or if one section of the heater of V-106 opened up, then the combination hot resistance would rise only to approximately seven ohms, and the voltage to seven volts.

14. OPERATING CONTROLS.

a. GENERAL.—An explanation in general terms of the function of each operating control is given in figure 4-1, and the equipment operating controls are identified with their respective circuits in the equipment block diagram of figure 2-1, while each control is

identified on the equipment schematic diagram of figure 7-6 by means of the appropriate circled letter and panel marking. A detailed description of the actual electrical functions of the equipment operating controls follows.

b. **(A)** POWER switch S-110 controls the actual application of power to the entire equipment, connecting the a-c line to the primary circuit of power transformer T-104 when set to the ON position.

c. **(B)** BAND switch S-102 connects the proper tuning coil and coupling link into the input tuning circuits so that the equipment will tune over the selected tuning range. On the three higher-frequency positions this switch short-circuits the adjacent lower-frequency tuning coil to prevent tuning interaction.

d. **(C)** MONITOR-CALIBRATE switch S-101 connects the input tuning circuits either to the input jack J-101 or to the output of the calibrating oscillator. In the MONITOR position, input tuning circuits are connected to input jack J-101, and the calibrating oscillator plate voltage is disconnected. In the CALIB. FREQ. A position, input tuning circuits are connected to output of the calibrating oscillator, plate voltage is applied to Z-101A section of dual-triode calibrating oscillator tube V-108. In CALIB. FREQ. B position, input tuning circuits are connected to the output of calibrating oscillator, and plate voltage is applied to the Z-101B section of dual-triode calibrating oscillator tube V-108.

e. **(D)** TUNE-MEASURE switch S-130 selects the mode of operation of the indicator circuits. In the TUNE position this switch connects the a-c output of the discriminator V-105 and buffer amplifier V-106A to the phone jack J-101, and connects a portion of the d-c output of the discriminator to the grid of the meter amplifier V-106B and places a tuning bias on the meter M-101. In the UNKEYED SIGNAL position a portion of the d-c output of the discriminator is applied to the grid of meter amplifier V-106B and the tuning bias is removed from meter M-101. In the KEYED SIGNAL position the a-c output of the discriminator V-105 and buffer amplifier V-106A is connected to meter rectifier V-107, and the output of V-107 is coupled to the grid of meter amplifier V-106B.

f. **(E)** R. F. GAIN control R-110 varies a positive bias on the cathodes of the mixer V-101 and i-f amplifier V-102 to adjust the overall sensitivity of the equipment by utilizing the super-control (remote cut-off) characteristics of these tubes.

g. **(F)** AUDIO GAIN control R-130 varies the resistance in series with the headphones to control the amplitude of audio signal voltage effective in the headphones over a limited range. The maximum resistance that may be placed in series with the headphones is 10,000

ohms, so that the total range of audio gain variation is approximately 10 db., and the gain cannot be reduced to the point of zero response in the headphones. Thus, the modulation component of a keyed frequency-shift signal will be audible even if the audio gain control is accidentally left in the minimum gain position.

h. **(G)** PHONES J-102.—During initial rough tuning of the equipment to a keyed frequency-shift signal, an a-c voltage corresponding to the modulation component of this signal is available at phone jack J-102, where a pair of headphones (having a sensitivity of 1000 to 5000 ohms) may be inserted.

i. **(H)** FINE TUNING control R-165 is connected in series with the small value of capacitance of C-165 (two micro-microfarads) between the cathode of the local oscillator V-109 and ground. The combination is thus connected across the cathode portion of the local oscillator tank circuit. Varying the resistance of FINE TUNING control R-165 varies the effective capacitive reactance across this portion of the local oscillator tank circuit and thus varies the local oscillator frequency. Since the total capacitive reactance variation is small, and since it is effective across only a relatively small portion of the local oscillator tank circuit, its effect on the fundamental frequency of the local oscillator is negligible at the low-frequency end of the local oscillator tuning range, and remains small even at the high-frequency end of this range. However, when the equipment is tuned to signals within the higher-frequency bands, where harmonics of the local oscillator are used, and particularly when the equipment is tuned near the higher-frequency limits of these bands, where the local oscillator tuning capacitor approaches its minimum capacitance, the fine tuning control becomes highly effective and necessary for precise tuning.

j. **(I)** METER ZERO SET control R-140 forms part of a voltage divider network across the 105-volt regulated supply line, and controls the effective bias on the grid of meter amplifier V-106B to adjust meter M-101 to read zero when the TUNE-MEASURE switch S-130 is in the KEYED SIGNAL position.

k. **(K)** METER-CALIB. control R-145 is connected in series with meter M-101 when TUNE-MEASURE switch S-130 is in either the UNKEYED SIGNAL or KEYED SIGNAL position, and controls the effective sensitivity of the meter so that the actual meter reading, for a given voltage at the grid of meter amplifier V-106B, may be varied over a considerable portion of the meter range. This control is provided for adjustment of the meter calibration during initial equipment self-calibration.

l. **(L)** TUNING control C-105 and C-160 varies the local oscillator tuning capacitor C-160 and input tuning capacitor C-105 to tune their respective circuits over the particular band in use. The tuning knob shaft

proper is coupled mechanically to C-160, and C-105 is ganged to C-160 through a gear and worm-and-follower assembly, so that backlash in local oscillator tuning is virtually eliminated.

m. INPUT jack J-101 connects the signal to be monitored (from a matching cable, if used, or simply from random coupling) into the input tuning circuits through the contacts of the MONITOR-CALIBRATE switch S-101.

n. Line voltage selector switch S-111 controls the connections to the twin primaries of power transformer T-104. In the 115-volt position, this switch connects the two primaries in parallel, while in the 230-volt position the two primaries are connected in series. The connections between the power transformer primaries and this switch are important, since the conditions of opposed parallel or inverse series connection of the primaries will produce the effect of a direct short-circuit and are therefore to be avoided.

15. APPENDIX — FREQUENCY-SHIFT TELEGRAPH SYSTEM.

(See figure 2-5.)

A discussion of the characteristics of the frequency-shift telegraph system is presented here to supplement the theory of operation of the present equipment. This description should provide a more complete understanding of the role that the monitor equipment plays in maintaining proper operation of the system. Personnel well-acquainted with the technical features of the frequency-shift telegraph system should proceed to the next section for information on installation procedures.

a. Frequency-shift telegraphy is a form of frequency modulation in which the signalling is accomplished by shifting a constant amplitude carrier between two frequencies representing the marking and spacing conditions of the telegraph code. The transmitter emits two different frequencies, one for mark and one for space, rather than the usual single frequency carrier.

b. The main advantages of frequency-shift carrier telegraphy (FS) may be applied to any carrier telegraph circuit, but it provides striking advantages in high-frequency radio transmission. Most of the advantages of FS over the amplitude modulated or "on-off" (AM) method are the ability to accept rapid level changes, which results in better stability and lower distortion, and an improvement in signal-to-noise ratio, which permits a reduction in the carrier amplitude. Thus, frequency variations in FS telegraphy correspond to the amplitude variations in AM or CW telegraphy; the signal transitions in FS are

represented by frequency-time transients, while in the AM case they are amplitude transients.

c. There are many methods of controlling the required shift in frequency, but the one found most successful is the use of a reactance tube and a self-excited oscillator. The output of this oscillator is mixed with the transmitter oscillator, which is lower in frequency by an amount equal to the frequency of the self-excited oscillator, to produce two new frequencies in the output of the combination, one representing the sum of the two frequencies and the other the difference frequency. By the use of a tuned circuit, one is selected and the other is rejected. In normal practice, the sum frequency is selected and the difference frequency is rejected. When the transmitter output frequency is a multiple of that of the oscillator by the use of frequency multipliers, the amount of shift must be reduced by a proportionate amount in order to maintain a given amount of deviation over the frequency range of the transmitter.

d. A typical transmitter circuit normally used for practical FS transmission is shown in figure 2-5. A d-c telegraph wave, after suitable shaping, is caused to frequency-modulate an intermediate frequency of 200 kc, which in turn, amplitude-modulates a radio-frequency carrier from a crystal-controlled oscillator. The upper sideband of this latter modulation is an FS signal and is selected and amplified sufficiently to drive the first amplifier or multiplier stage of the transmitter. The 200-kc oscillator is frequency-modulated by a reactance modulator, which by feeding a leading or lagging quadrature component of current into the oscillator tuned circuit, increases or decreases the frequency. By operating the reactance modulator within its linear range, the frequency-shift waveform is made the same as the d-c telegraph waveform from the modulator. A d-c amplifier stage, designated "keying circuit" in figure 2-5 is provided to furnish a modulating wave effectively isolated from amplitude and wave front variations of the incoming telegraph signals. The d-c telegraph signals may be polar or neutral and are often obtained from a tone demodulator unit which allows keying from a remote point. The shift may thus be varied continuously, or in definite steps to allow for subsequent frequency multiplications, by suitable attenuation controls. Controlling the shift in this manner keeps the instabilities of the reactance modulator a constant percentage of the frequency shift, which would not be the case if the shift were controlled by adjusting the amplitude of the modulating wave. The use of a balanced instead of an unbalanced reactance modulator minimizes variation of the mean frequency and also allows the shift to be varied without the shift affecting the mean frequency.

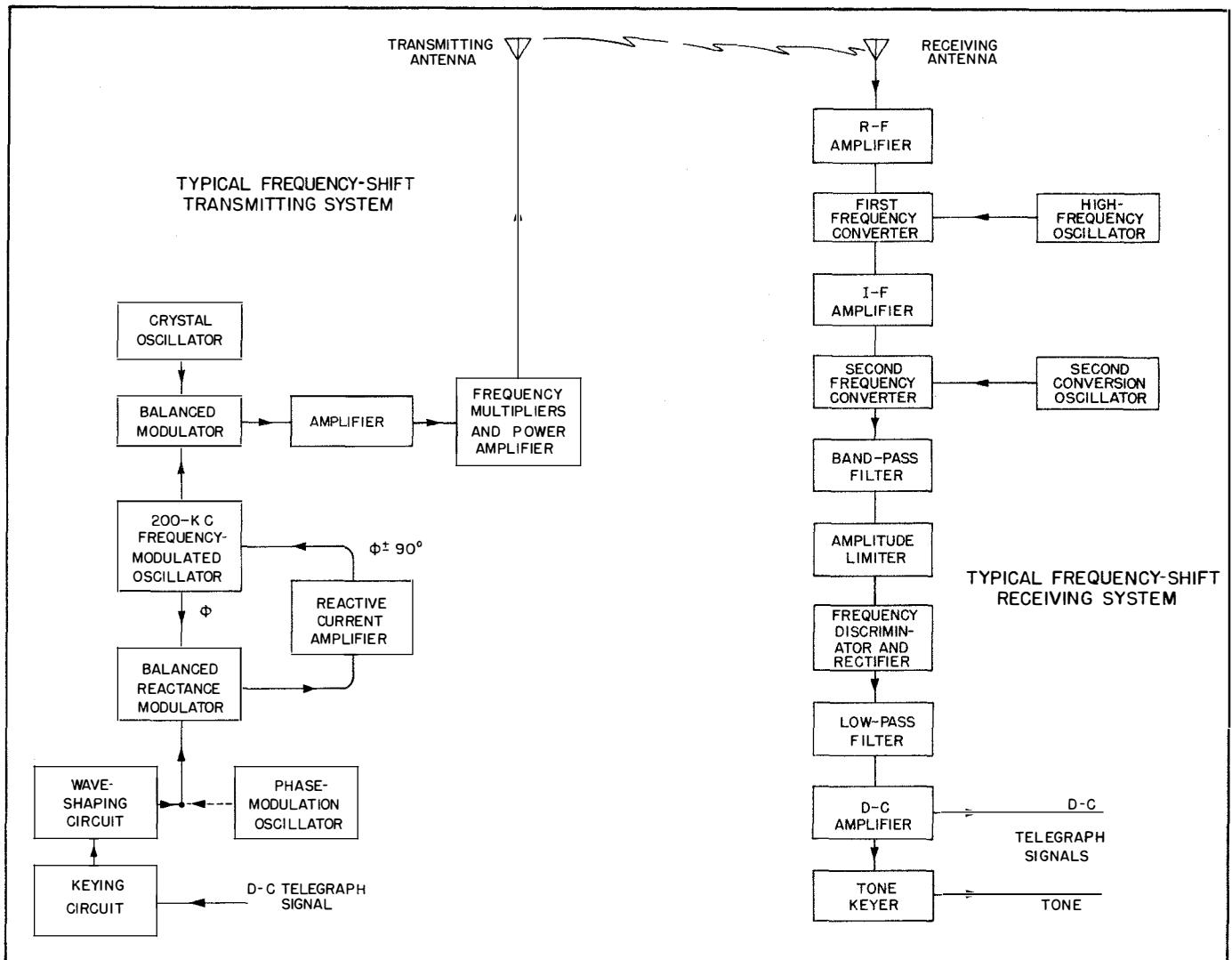

Figure 2-5. Typical Frequency-Shift Block Diagram

e. The frequency-shift signal transitions are wave-shaped, to restrict sideband radiation, by means of a low-pass filter in the d-c telegraph signal path to the reactance modulator. The low-pass filtering is made adjustable to accommodate a range of signalling speeds.

f. Phase modulation may readily be added to the signal in this type of exciter by superimposing the desired sine-wave modulating frequency on the telegraph signal wave input to the reactance modulator. This phase modulation is useful in minimizing errors due to selective fading.

g. To obtain optimum results in FS radio telegraph transmission and to allow close spacing of channels, a high degree of frequency stability is necessary. An overall frequency stability of ± 100 cycles is desirable in a system using a value of frequency-shift between 500 and 1000 cycles. A frequency-shift exciter of the type just described, with the crystal and 200 kc FS

oscillator located in a temperature-controlled oven, usually has a frequency stability such that the mean r-f frequency may be held to within ± 50 cycles up to frequencies of 20 mc over ordinary periods of operation on any one frequency. One of the advantages of this type of exciter is that small inaccuracies in crystal frequency may be compensated for by adjusting the mean frequency of the 200-kc oscillator.

h. A typical receiver is also shown in the system block diagram of figure 2-5. Except for the amplitude limiter and the frequency discriminator and rectifier, the AM and FS receiving circuits are more or less conventional. The FS receiver normally uses double conversion, but otherwise the remaining circuits are essentially the same. The output from the second frequency conversion stage may be either in the audio range or at a considerably higher frequency such as 50 kc. Following the second converter is a band-pass filter which determines the final overall bandwidth

before demodulation. The AM (C-W) signals are normally amplified and rectified to give a d-c telegraph signal, while FS signals are amplitude-limited and passed through a frequency discriminating network and then rectified to give a d-c telegraph signal. Beyond this point the two systems are again identical. The d-c signals pass through a low-pass filter to remove carrier ripple and higher-frequency noise components, and then are amplified to a suitable level to operate automatic recording or printing apparatus. The d-c signals may also be used to modulate an audio frequency so as to pass the signals to a remote point.

i. The FS transmitter output must be confined to the bandwidth allotted for such service. Since ordi-

narily it is desirable to use as much frequency-deviation as possible within the assigned band of frequencies, but not so much as to exceed the bandwidth requirements, all FS transmissions should be carefully monitored for the amount of frequency-shift being used. In many other applications, particularly where sharply tuned filters are employed, it is of utmost importance that the exact required amount of frequency-shift be established and maintained. Thus, an accurate method of measuring and monitoring transmitter frequency-shift is required if the maximum benefits of FS telegraphy are to be attained. Frequency Shift Monitors OCT-2 and OCT-3 are equipments designed for this function.

SECTION 3 INSTALLATION

1. SCOPE AND CONTENTS.

a. The installation procedures of the Frequency Shift Monitors OCT-2 and OCT-3 are covered in this section along with the preliminary tests and adjustments necessary to place the equipment in operation. Preparation of the frequency-shift monitor equipment for operation involves the following sequence of steps:

- (1) Planning types of installations and power sources.
- (2) Unpacking and inspecting the equipment.
- (3) Readyng the equipment.
- (4) Preparing the ship or shore installation.
- (5) Checking the complete installation.

b. When once set-up for operation, the equipment will normally require no adjustments other than the periodic calibration check to assure accuracy in the frequency-shift measurements. However in the installation procedure, the calibration check also serves the very useful purpose of providing a quick-check on the performance of the equipment. For further information on the control settings and operational adjustments refer to Section 4—Operation.

2. TYPES OF INSTALLATIONS.

a. As determined by local conditions, the installation of the present equipment will be either in a shock-mounted cabinet (OCT-2) which is normally intended for shipboard use, or the equipment will be supplied with dust covers for rack-and-panel mounting in shore-type installations (OCT-3). The differences between these two equipments are illustrated in figures 1-1, 3-1, and 3-2. Throughout this handbook, wherever any information is given without specific reference to either the Frequency Shift Monitor OCT-2 or OCT-3, the instructions apply equally well to both equipments.

b. For continuous monitoring of the frequency-shift being employed at the transmitter, the equipment should be placed so that frequency-shift or deviation meter M-101 may be easily observed.

3. PRIMARY POWER SOURCE REQUIREMENTS.

a. The Frequency Shift Monitors OCT-2 and OCT-3 require an a-c single phase 115- or 230-volt power source and will consume about 85 watts at the supply frequency of 50 to 60 cps.

CAUTION

The equipment will be damaged if it is connected to a power source of 400 cps or to another source other than 50 to 60 cps.

b. If a 230-volt source is to be used, the voltage selector S-111 on the rear of the chassis should be set to the 230 a-c position. This connects the two halves of the power transformer in series for operation at the higher voltages.

c. When operating on 115 volts, the protective fuses should have a rating of two amperes. The fuses and spare fuses normally supplied are rated at two amperes for the normal 115-volt operation. If operation on 230 volts is planned, all fuses should be replaced with those of one-ampere rating including the spare fuses, for proper protection at the higher voltage.

4. UNPACKING AND INSPECTING THE EQUIPMENT.

a. The equipment has been tested at the factory before shipment and careful handling will help to keep the equipment in proper working order. Carefully unpack the equipment and remove all the packing material used to hold the components and controls in place. During the unpacking procedure use extreme care to prevent damage to the unit or any of its component parts.

b. Check the equipment received against the accompanying packing lists and the list of equipment supplied, table 1-1 in Section 1 of this handbook. If damage is noted, Failure Reports should be issued through normal channels and in accordance with the instructions given in figure 7-1 of this handbook.

c. Make a thorough electrical inspection of the unit. Inspect the wiring carefully to ascertain that no connection has been loosened or removed from its original contact point. When making inspections take precautions not to disturb the original settings of the screw adjust potentiometers, padder and trimmer capacitors. These components have been properly adjusted during manufacturing tests and any disturbance of the settings will require precise adjustment as outlined in Section 7, "Corrective Maintenance" of this handbook.

d. It is good practice to check all the tubes in the equipment before placing them into operation. Replace any tubes found to be defective, but do not replace a tube otherwise, since the spares box might

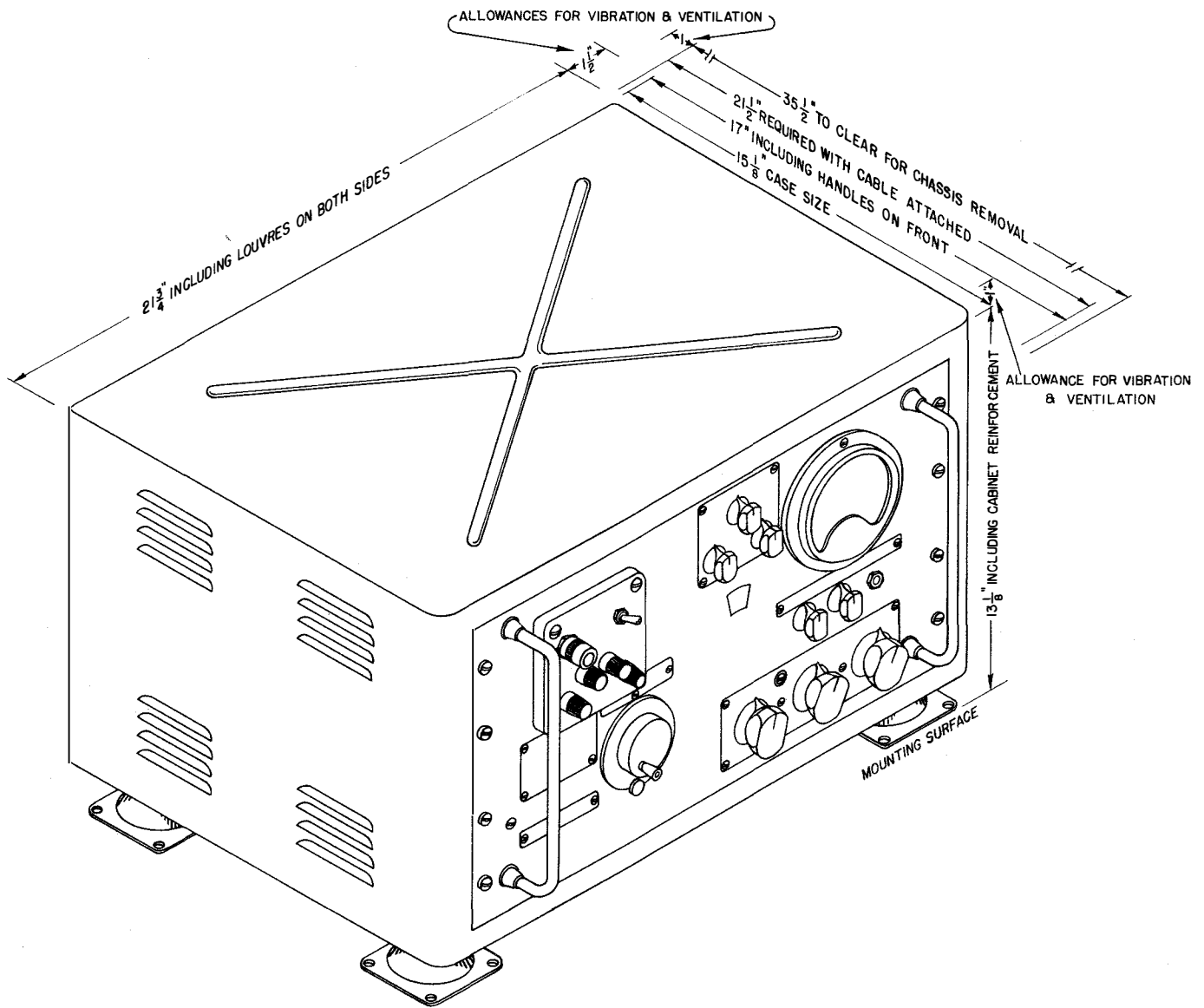

Figure 3-1. Frequency Shift Monitor OCT-2, Installation Diagram

soon contain many tubes whose exact age and condition would not be known. The tube numbers and their respective symbols appear alongside of each tube socket and no trouble should be encountered in replacing or servicing tubes.

5. READYING THE EQUIPMENT.

a. Visually inspect each unit to insure that all dust covers are in place, assembly hardware is secure, and that the mechanical operation of the controls is satisfactory.

b. Thoroughly bench-test the equipment in accordance with the maintenance procedures covered in Section 7. When the bench-tests have been completed, the equipment is ready for installation.

c. Set the primary voltage selector S-111 to the voltage source to be used, either 115 or 230 volts a-c. Install the proper fuses in the operating and spare fuse holders (two-ampere fuses for operation on 115 volts, and one-ampere fuses for use on 230 volts).

6. INSTALLATION OF THE FREQUENCY SHIFT MONITOR OCT-2.

(See figures 3-1 and 3-3.)

a. The dimensions given in figure 3-1 should be taken into consideration when installing the Frequency Shift Monitor OCT-2. All four mounting feet of the equipment should be placed on a flat surface, and if desired they may be secured to the mounting surface, although this is not necessary. Place the monitor where the frequency-shift meter M-101 may be observed from the operating position. The controls on the front panel should also be easily accessible. Allow room at the front of the equipment to allow the panel and chassis to be removed from the cabinet for servicing, and provide room at the rear for the power cable W-201. For vibration, ventilation, and servicing allowance, a mounting space 23-1/4" long x 36-1/2" deep x 13-1/8" high will be suitable.

b. The a-c power input receptacle is located on the rear of the monitor chassis, as shown in figure 3-3. Either 115 or 230 volts a-c may be brought into the unit from some convenient source by means of the 12-foot power cable W-201. The primary voltage selector should be checked and set if necessary to the setting of the voltage source used (either 115 or 230 volts a-c).

CAUTION

Failure to have the primary voltage selector switch in the proper position may result in improper operation or serious damage to the equipment.

c. Connect a set of headphones into the **(C)** PHONES jack J-102. The phones are used to assist in the tuning procedure, and are operative only in the TUNE setting of the **(D)** TUNE-MEASURE switch. The **(F)** AUDIO GAIN control R-141 sets the audio level in the headphones.

d. In some cases insufficient level may be obtained from the transmitter. Additional pickup may be obtained by loosely coupling to the transmitter and feeding the r-f to the monitor by means of a suitable length of coaxial cable connected to the INPUT jack J-101 by means of a UHF-type coaxial plug. Cable connections are illustrated in figure 3-3, and r-f cable fabrication data is given in figure 3-4.

Note

The equipment must receive r-f energy from a stage of the transmitter following the last stage of frequency multiplication. Approximately 15 millivolts to 20 volts r-f input is required for proper operation. The r-f level applied to the remaining circuits is controlled by the setting of the **(E)** R. F. GAIN control.

7. INSTALLATION OF THE FREQUENCY SHIFT MONITOR OCT-3.

(See figures 3-2 and 3-3.)

a. The space requirements of the Frequency Shift Monitor OCT-3 are given in figure 3-2. Since the present equipment is mounted in a rack, allowance for vibration is not necessary. However, allow 30-1/8 inches depth to facilitate dust cover removal. The panel is standard size and requires 10-1/2 inches of panel space in the rack. Check that the power cable W-201 has adequate clearance and that the primary voltage selector is set to the voltage of the power source (either 115 or 230 volts a-c). Also be sure that the correct fuses are installed in the equipment. Two-ampere fuses are required for operation on 115 volts, while one-ampere fuses are needed when 230-volt operation is contemplated.

CAUTION

Improper operation or serious damage to the equipment will occur if the primary voltage selector is not set to the proper position.

b. If insufficient r-f level is obtained from the transmitter, it may be necessary to obtain additional pickup by means of a co-axial cable connected to the INPUT jack J-101 and coupled to a stage of the transmitter following the last stage of frequency multiplication.

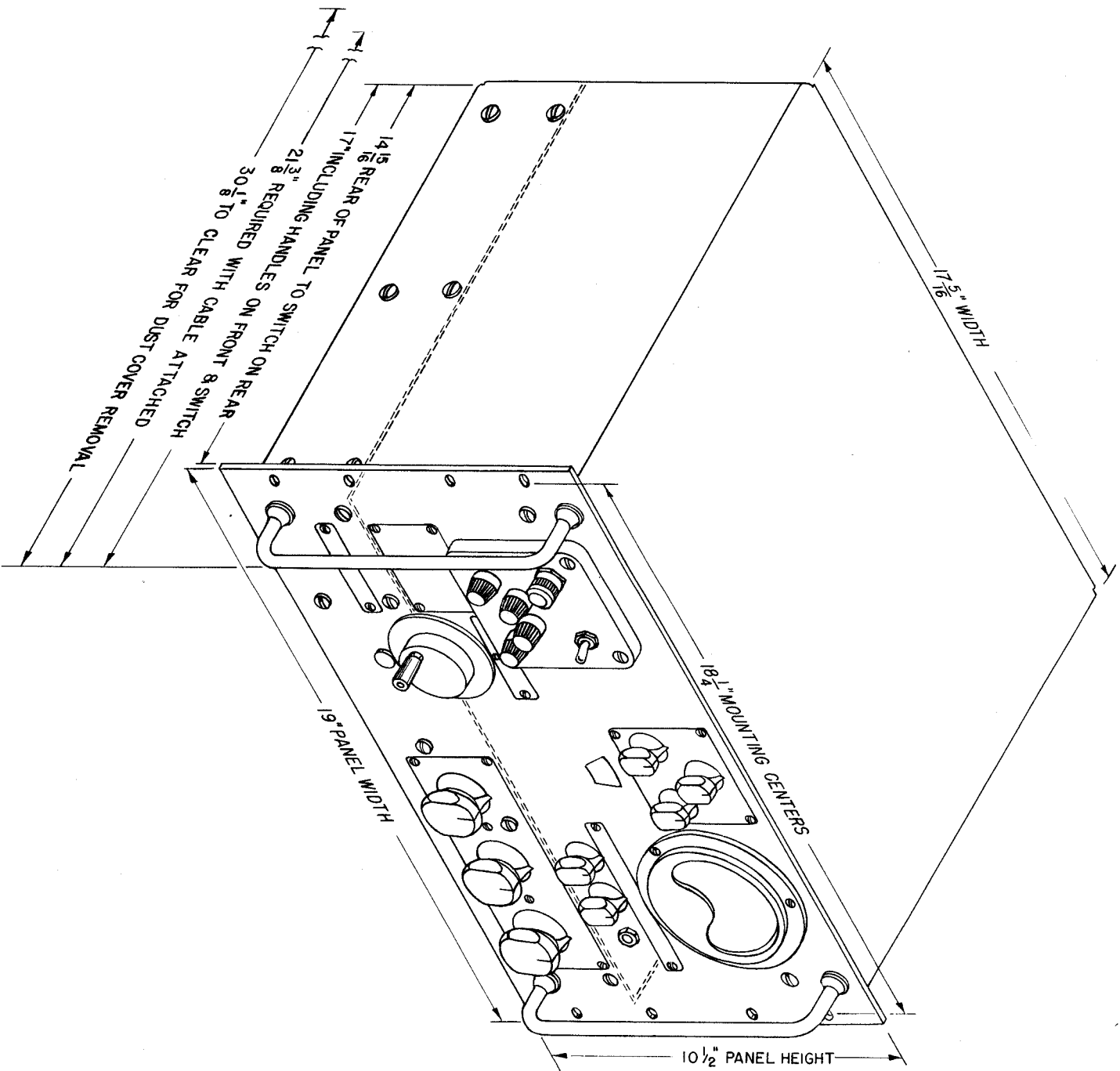

Figure 3-2. Frequency Shift Monitor OCT-3, Installation Diagram

c. Connect a set of headphones into the **Ⓞ** PHONES jack J-102. The headphones assist in the tuning procedure. Further information on the operational control settings and adjustments is given in Section 4 of this handbook.

8. CHECKING THE INSTALLATION.

a. Before power is applied to the equipment and before any operational adjustments or tests are begun, thoroughly check the complete installation. Be sure that the power selector switch S-111 is set to the power supply voltage to be used. Also check, and change if necessary, the operating and spare fuses (two-ampere fuses for 115 volts and one-ampere fuses

for operation on 230 volts). See that the power cable and the r-f pickup cable (if required) are secure and that the headphones are plugged into the **Ⓞ** PHONES jack J-102.

b. Power should be applied and an electrical check of the equipment should be completed before further use is attempted. If at any point the equipment appears to operate abnormally, turn off the power immediately, and check that the power selector switch is properly set and the supply voltage is correct. A very satisfactory quick-check on the equipment may be obtained by making an internal calibration check, as described in Section 4. For complete bench-test procedures refer to Section 7—Corrective Maintenance.

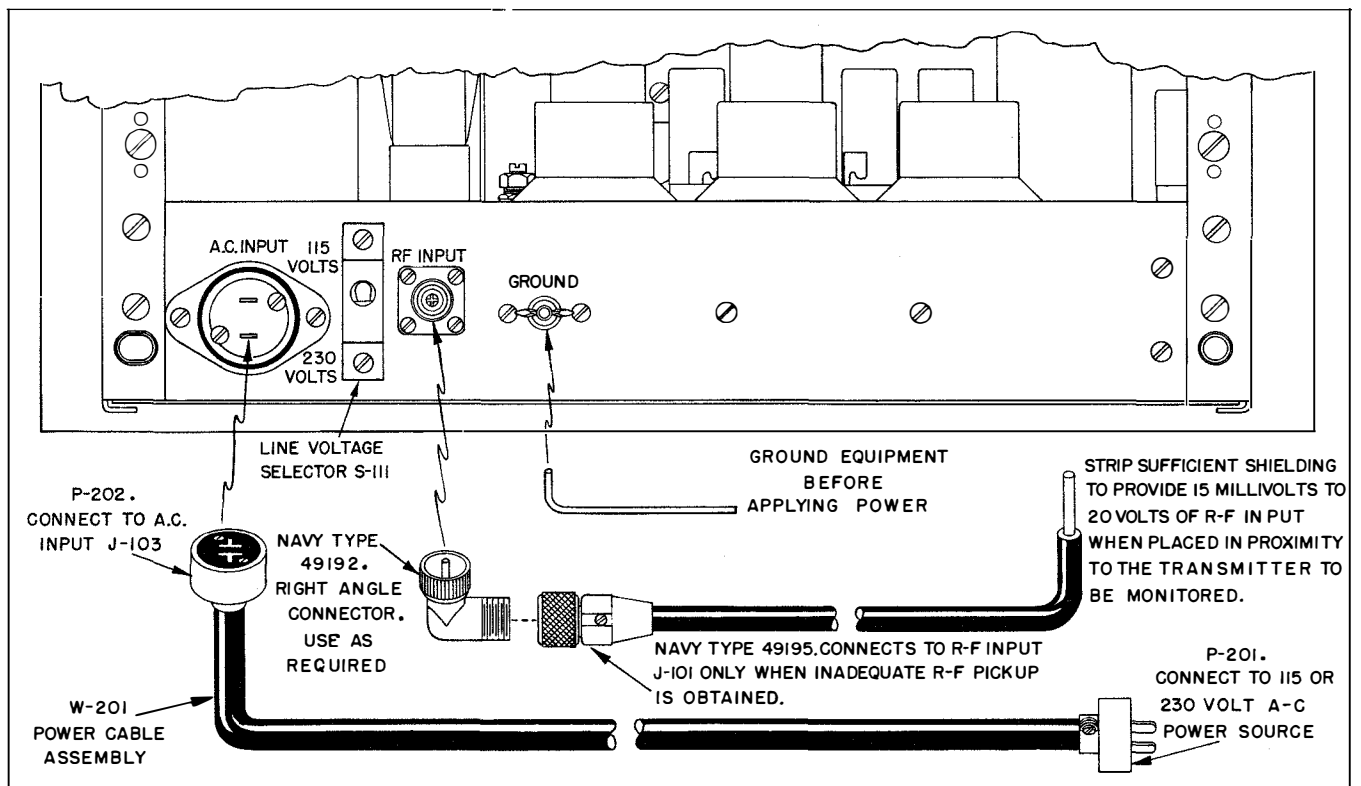

Figure 3-3. Cable Connections Diagram

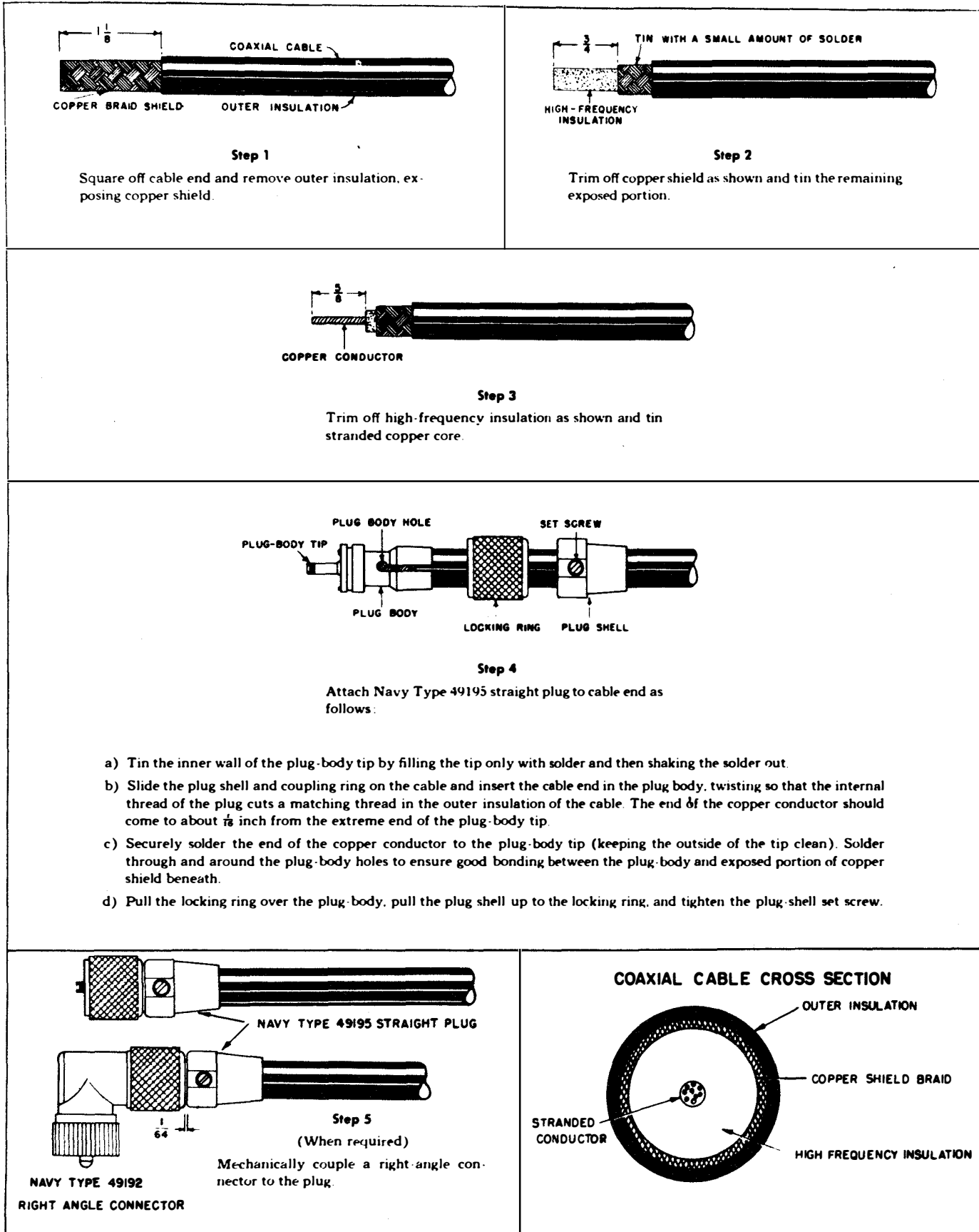

Figure 3-4. Cable Fabrication Data

SECTION 4

OPERATION

1. PRECAUTIONS TO BE OBSERVED.

a. When the installation has been completed and the preparatory adjustments described in Section 3 have been completed, the equipment is ready for operation. The actual operation of the present equipment is very simple, provided that the proper sequence of adjustments are made. As an aid to the sequence of operations to be followed, each front panel control is identified by a code letter in addition to its circuit function. The control settings are thus normally performed in a more or less alphabetical order.

b. All operating personnel should know the location, nomenclature, and function of all controls, and should be thoroughly familiar with the calibration and frequency-shift measurement procedures. Adequate knowledge of the operational procedures will permit the operator to establish and maintain the desired frequency-shift measurement accurately and efficiently.

c. The RF Monitor permits the continuous monitoring of the space-to-mark frequency deviation of any frequency-shift transmitter using up to 1500 cycles per second frequency-shift over a range of one to 26 megacycles.

Note

The equipment must receive r-f energy from a stage of the transmitter following the last stage of frequency multiplication. Otherwise the frequency-shift indication on the meter will be in error.

d. For reliable and accurate frequency-shift indication, the initial meter zero-set adjustment and the calibration procedure must be completed before any measurements are taken.

CAUTION

Failure to have the primary voltage selector switch in the proper position will either result in improper operation or serious damage to the equipment.

e. It is of utmost importance that the primary voltage selector switch S-111, located on the rear of the chassis, be set to the voltage of the power source to be used (either 115 or 230 volts, 50 to 60 cps a-c) before power is applied to the equipment. Also check that two-ampere fuses are used on 115 volts a-c, and

that one-ampere fuses are used if the equipment is operated on 230 volts a-c, in order to protect the equipment in case of overload.

2. OPERATING PROCEDURE.

(See figure 4-1.)

a. A summary of the functions of each control, and the operational control settings and procedures, is presented in figure 4-1. Reference to this chart will provide a clear understanding of the functions of all controls and the reasons underlying the adjustment sequence.

b. The entire operation procedure evolves around four basic procedures.

- (1) The meter zero-set adjustment.
- (2) The calibration procedure.
- (3) Frequency-shift measurement of unkeyed signals.
- (4) Frequency-shift measurement of keyed signals.

c. These four operational procedures are covered fully in the following paragraphs. Throughout the discussion of the operation procedure, frequent reference should be made to figure 4-1. Although there is some duplication in the various procedures, complete information is nevertheless given for each phase of operation. All controls are referred to by their code letters as well as by circuit functions, to assist in identifying each control and stressing the sequence to be followed.

3. THE METER ZERO-SET ADJUSTMENT.

a. The accuracy of the frequency-shift measurement is adversely affected by the meter zero-set adjustment. While the equipment maintains its calibration over long periods of time, it is important that the initial zero-set adjustment be made accurately. The meter zero-set adjustment is part of the calibration procedure, and its setting affects the calibration and consequent frequency-shift measurements.

b. The frequency-shift meter is adjusted to zero by following the simple procedure below. Always allow at least five minutes after the equipment is turned on, in order for the circuits to reach stable operating temperature.

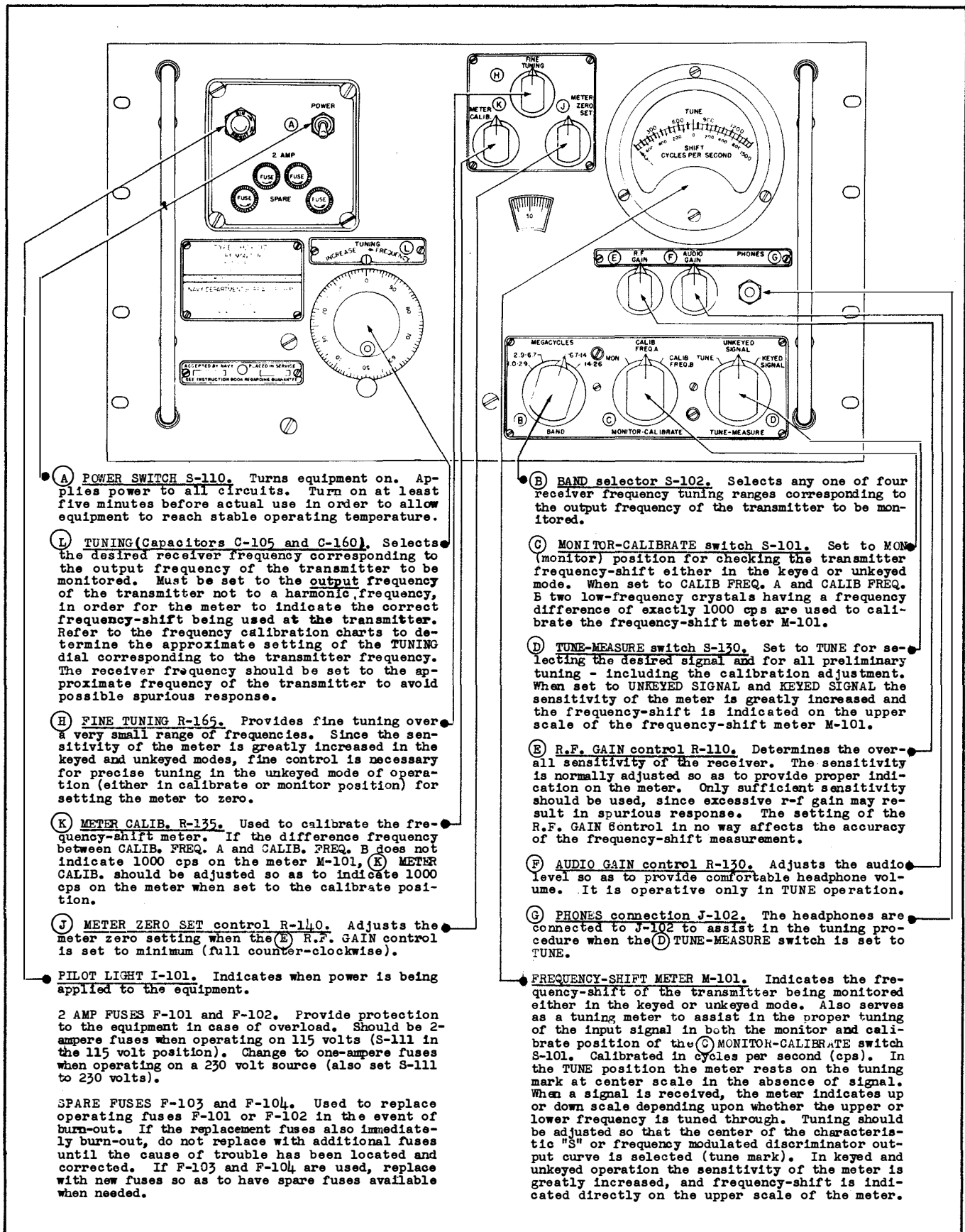

Figure 4-1. RF Monitor, Operating Instructions

- (1) Set **(E)** R.F. GAIN control to zero (full counter-clockwise setting).
- (2) Set **(D)** TUNE-MEASURE switch to KEYED SIGNAL.
- (3) If required, adjust **(J)** METER ZERO SET for zero reading on the upper-scale of the frequency-shift meter (left-hand zero).

4. THE CALIBRATION ADJUSTMENT.

a. The frequency-shift calibration of the meter should be checked at periodic intervals to assure reliability and accuracy of the frequency-shift indication. The meter zero-set adjustment as described above should always be completed first before attempting to calibrate the equipment. It is necessary to make a calibration check whenever the equipment is to be used after periods of inactivity, in which case at least five minutes should be allowed for the equipment to reach stable operating temperature, and the meter zero-set adjustment described above should, of course, be completed first.

b. Normally, after initial calibration, the equipment will not require continual adjustment. It is good practice, however, to check the calibration at periodic intervals to assure that maximum accuracy of the equipment is available at all times. The operator should thoroughly understand the following procedure.

- (1) Set **(C)** MONITOR-CALIBRATE switch to CALIB FREQ. A.
- (2) Set **(D)** TUNE-MEASURE switch to the TUNE position.
- (3) Switch the **(B)** BAND selector to the 1.0—2.9 megacycle range.
- (4) Turn **(E)** R.F. GAIN to maximum (full clockwise position).
- (5) Set **(L)** TUNING to approximately one mc (refer either to the approximate frequency calibration charts supplied with the equipment or to figures 4-1 or 4-2).
- (6) Tune **(L)** TUNING through the characteristic frequency modulation discriminator "S" curve. Adjust **L** TUNING until the meter points to the TUNE mark at center scale, midway between the upper and lower meter indication.
- (7) Set **(D)** TUNE-MEASURE switch to UNKEYED SIGNAL.
- (8) Adjust **(H)** FINE TUNING until the meter reads zero on the upper scale (left-hand zero).
- (9) Set **(C)** MONITOR-CALIBRATE switch to CALIB FREQ. B.

- (10) If necessary, adjust **(K)** METER CALIB. until the meter indicates exactly 1000 cycles per second on the upper scale of the frequency-shift meter. The indication on the meter may now be relied upon for accurate measurements, either for keyed or unkeyed signals.

5. FREQUENCY-SHIFT MEASUREMENT OF UNKEYED SIGNALS.

a. The meter zero-set and calibration procedures should be completed before any frequency-shift measurements are attempted. Refer to figure 4-1 to obtain a clearer picture of the sequence of operations. In the unkeyed signal methods of measuring frequency-shift, the difference frequency between the space and mark r-f frequencies is measured. Thus, the transmitter must be manually keyed from the space to the mark frequency.

b. When monitoring keyed signals, such as during periods of transmitter traffic, the equipment is operated under the keyed signal condition as explained in paragraph 6.

c. The first step in measuring frequency-shift is, of course, the calibration procedure, if it has not already been completed. The procedure for obtaining the frequency-shift indication for unkeyed signals is given below.

- (1) Switch **(A)** POWER to on, and calibrate the equipment as described in paragraph 4.
- (2) Set **(B)** BAND switch to the frequency range corresponding to the output frequency of the transmitter to be monitored.
- (3) Set **(C)** MONITOR-CALIBRATE switch to MON.
- (4) Set **(D)** TUNE-MEASURE switch to TUNE.
- (5) Set **(E)** R.F. GAIN to maximum, unless the output of the transmitter has previously been monitored and the r-f level is known. It is desirable to use the minimum amount of gain that will still assure limiting action, so as to reduce the possibilities of spurious response. Limiting is indicated by maximum meter reading, in the TUNE position of the **(C)** MONITOR-CALIBRATE switch, when tuned for maximum upward or downward deflection on the "S" curve.
- (6) Refer to the frequency calibration charts supplied with the equipment or to figure 4-2 or 4-3, and adjust **(L)** TUNING to the approximate frequency of the signal to be monitored. Tune through the characteristic frequency modulation discriminator output curve, as evidenced by an increase and decrease in meter reading from the center-zero position. Adjust **(L)** TUNING to the center of the "S" curve (meter reading of center-scale zero at TUNE mark).

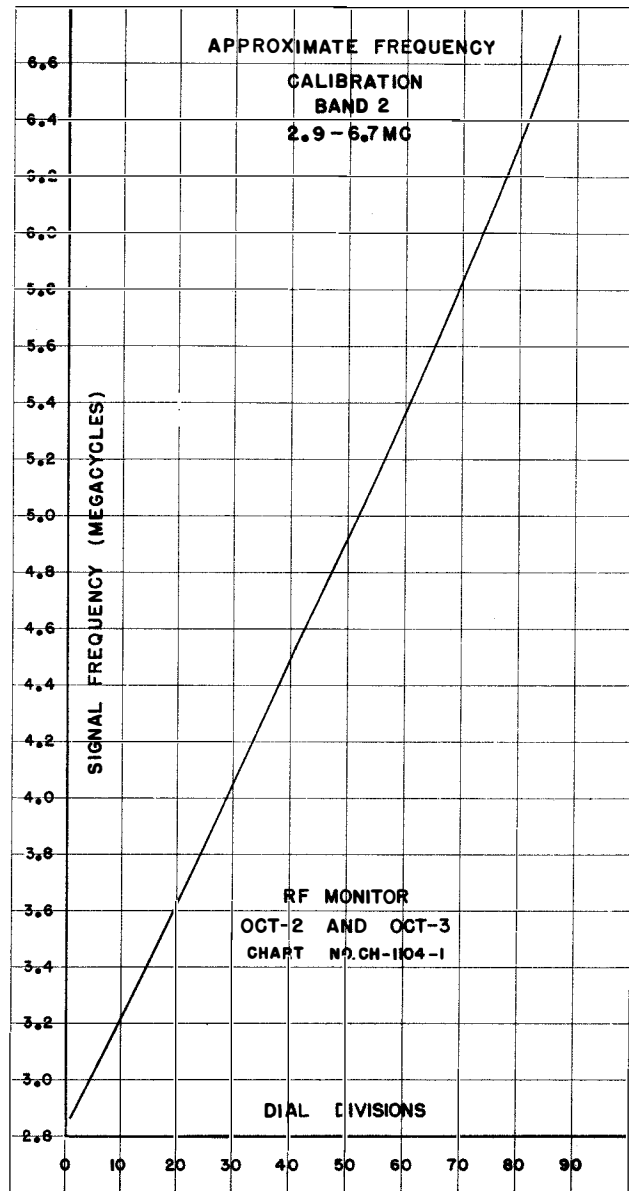
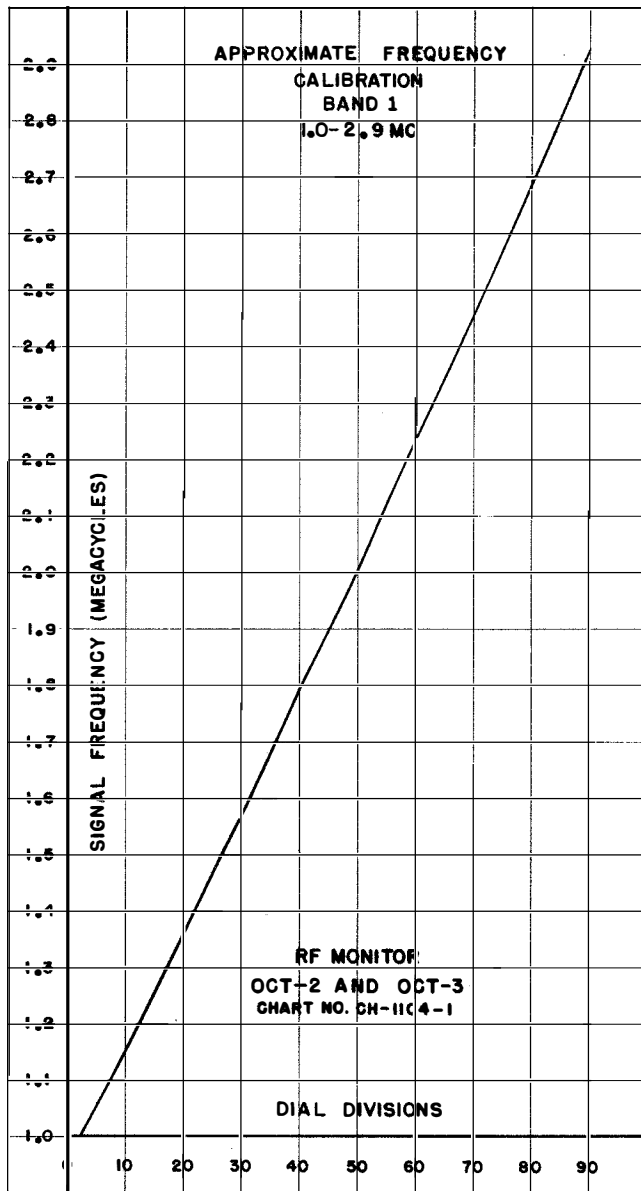

Figure 4-2. Approximate Frequency Calibration Charts, Bands 1 and 2

(7) Set **(D)** TUNE-MEASURE switch to UNKEYED SIGNAL.

(8) Adjust **(H)** FINE TUNING for zero reading on the upper-scale (left-hand zero).

(9) Shift the transmitter frequency to mark by closing the key.

(10) The transmitter frequency-shift is indicated directly on the meter in cycles per second.

6. FREQUENCY-SHIFT MEASUREMENT OF KEYED SIGNALS.

a. When the equipment is operated in the keyed signal mode, continuous monitoring of transmitter frequency-shift up to 1500 cps is obtained on the meter.

Variations in keying speeds down to 40 wpm (20 cps) do not affect the accuracy of the frequency-shift indication.

b. The tuning procedure for keyed signals is similar to that for the unkeyed signal and calibration procedures, except that headphones may be used to assist in properly tuning the keyed frequency-shift signal. The procedure for monitoring the frequency-shift of keyed signals is given below.

(1) Switch **(A)** POWER to ON, and calibrate the equipment as covered in paragraph 4.

(2) Set **(B)** BAND selector to the frequency range corresponding to the output frequency of the transmitter to be monitored.

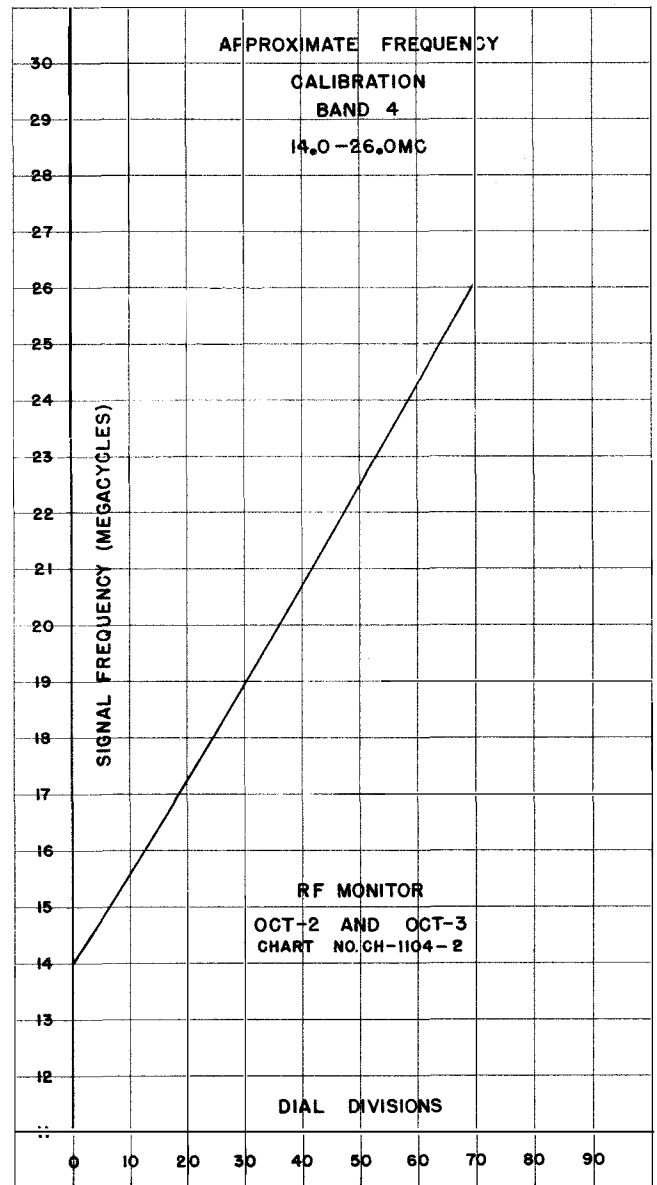
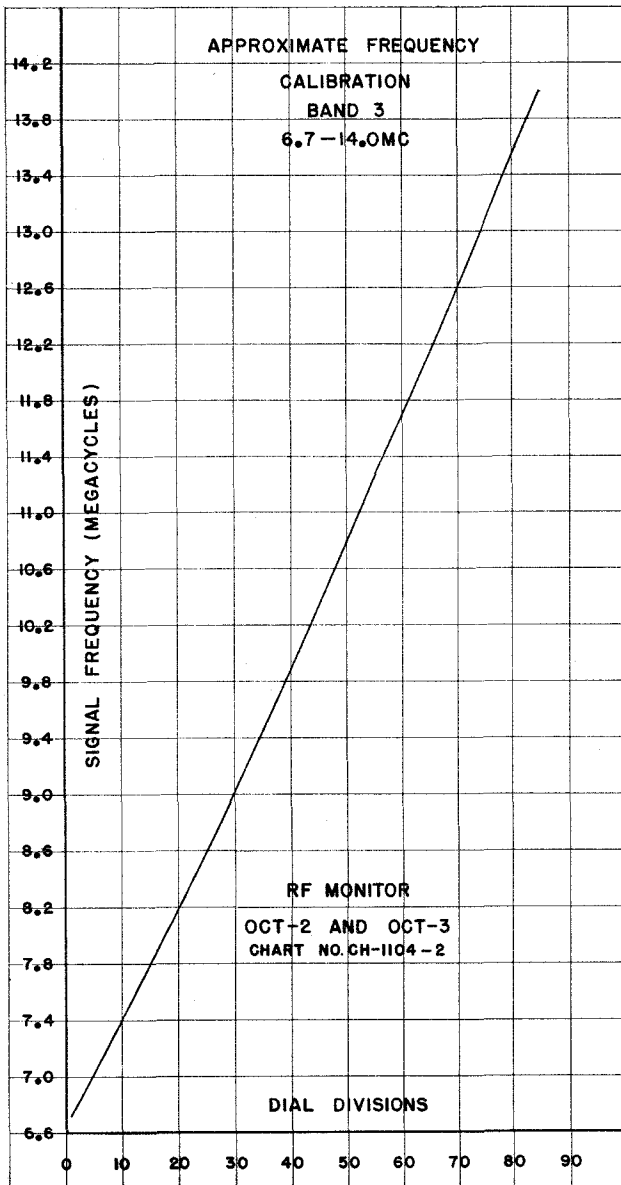

Figure 4-3. Approximate Frequency Calibration Charts, Bands 3 and 4

- (3) Set **(C)** MONITOR-CALIBRATE switch to MON.
- (4) Set **(D)** TUNE-MEASURE switch to TUNE.
- (5) Set **(E)** R.F. GAIN to maximum, unless the output of the transmitter has been previously monitored, and the r-f level is known. (Use only sufficient r-f gain to produce limiting action in order to avoid any spurious responses. Limiting is indicated by maximum meter reading, in the TUNE position of the **(C)** MONITOR-CALIBRATE switch, when tuned for maximum upward or downward meter deflection on the "S" curve.)
- (6) Insert a pair of headphones (1000 to 5000 ohm impedance) into the **(G)** PHONES jack J-102.
- (7) Refer to the frequency calibration chart, and

adjust **(L)** TUNING to the approximate frequency of the signal to be monitored. Tune through the characteristic frequency modulation discriminator output curve, as indicated by key-click transients in the headphones and an increase and decrease in meter deflection from the normal center-zero position. Adjust **(L)** TUNING to the center of the "S" curve (meter reading of center-scale zero at the TUNE mark). The keying transients or key clicks should also be heard in the monitor headphones as an aid to proper tuning or signal identification.

- (8) Set **(D)** TUNE-MEASURE to KEYED SIGNAL. The transmitter frequency-shift is now indicated directly on the upper-scale of the meter in cycles per second.

SECTION 5 OPERATOR'S MAINTENANCE

1. ROUTINE CHECK CHART.

(See table 5-1.)

a. The accuracy of the frequency-shift measurement depends upon several adjustments which must be made at periodic intervals by the operator. The internal calibration should be checked to assure that the frequency-shift reading on the meter M-101 is correct. The calibration procedure is covered in Paragraph 4 of this section, and the routine operator's checks are covered in table 5-1.

b. The equipment is designed to operate on either 115 or 230 volts a-c. Although the equipment will normally be set up for one power source or the other, the operator may have occasion to adjust the equipment for operation on the alternative power source. This is accomplished by setting the primary selector switch S-111 (located on the rear of the chassis) to

the power source voltage to be used (either 115 or 230 volts a-c).

c. The equipment is supplied with two-ampere fuses in the operating and spare-fuse holders for operation on 115 volts a-c. If operation on 230 volts a-c is planned, the fuses must be replaced with one-ampere fuses to provide proper protection to the equipment. Additional fuse and tube replacement data is given in the following paragraphs.

2. FUSE LOCATIONS AND SYMPTOMS OF FAILURE.

a. There are two operating and two spare fuses in the equipment. The fuse holders marked 2 AMP in the upper left hand corner of the front panel contains the two-ampere fuses which provide protection for the equipment when operating on 115 volts a-c (these should be changed to one-ampere fuses when operating on 230 volts a-c). If there is total failure of the equipment, one or both of these fuses may be

TABLE 5-1. ROUTINE CHECK CHART

What To Check	How To Check	Precautions
Pilot Lamp.	Throw (A) POWER switch to ON.	Pilot lamp should light. If it does not, check lamp by replacement. If pilot lamp still does not light, check fuses.
Fuses.	Remove each fuse from its fuseholder on front panel.	Defective fuses are usually indicated by a visual inspection, although not always. Check each with an ohmmeter to be sure. If fuses are good, check power cord.
Power Cord.	Check to see that power cord is securely connected at both ends, and check carefully for evidences of insulation decay or fraying due to crushing or excessive bending. Check plug contacts to see that they are bright and clean.	Erratic operation may be encountered due to poor or intermittent contact in the power cord or receptacles. There should be no evidence of cable insulation failure, or of corrosion or accumulated dirt in or around contacts of connectors or a-c line plug.
Controls and Switches.	With power removed from the equipment, operate each front panel control and switch through its full range.	Control action should be smooth, noiseless and continuous. Control knobs should be tight on shafts. Switch action should be firm and positive.
Zero-Set Adjustment.	Perform the meter zero set adjustment in accordance with paragraph 4.a. of this section.	If the equipment meter cannot be adjusted to zero indication, report condition to the maintenance crew.
Equipment Calibration.	Perform the calibration checking procedure in accordance with paragraph 4.b. of this section	If the equipment does not respond properly during this check, report condition to the maintenance crew.
Equipment Sensitivity.	After performing the calibration checking procedure outlined in paragraph 4.b. of this section, slowly turn (B) R.F. GAIN counter-clockwise until the equipment meter indication first begins to decrease. This point is the limiting threshold.	The limiting threshold should occur at least one-quarter turn of (B) R.F. GAIN from its full clockwise position. If this is not the case, report condition to the maintenance crew.

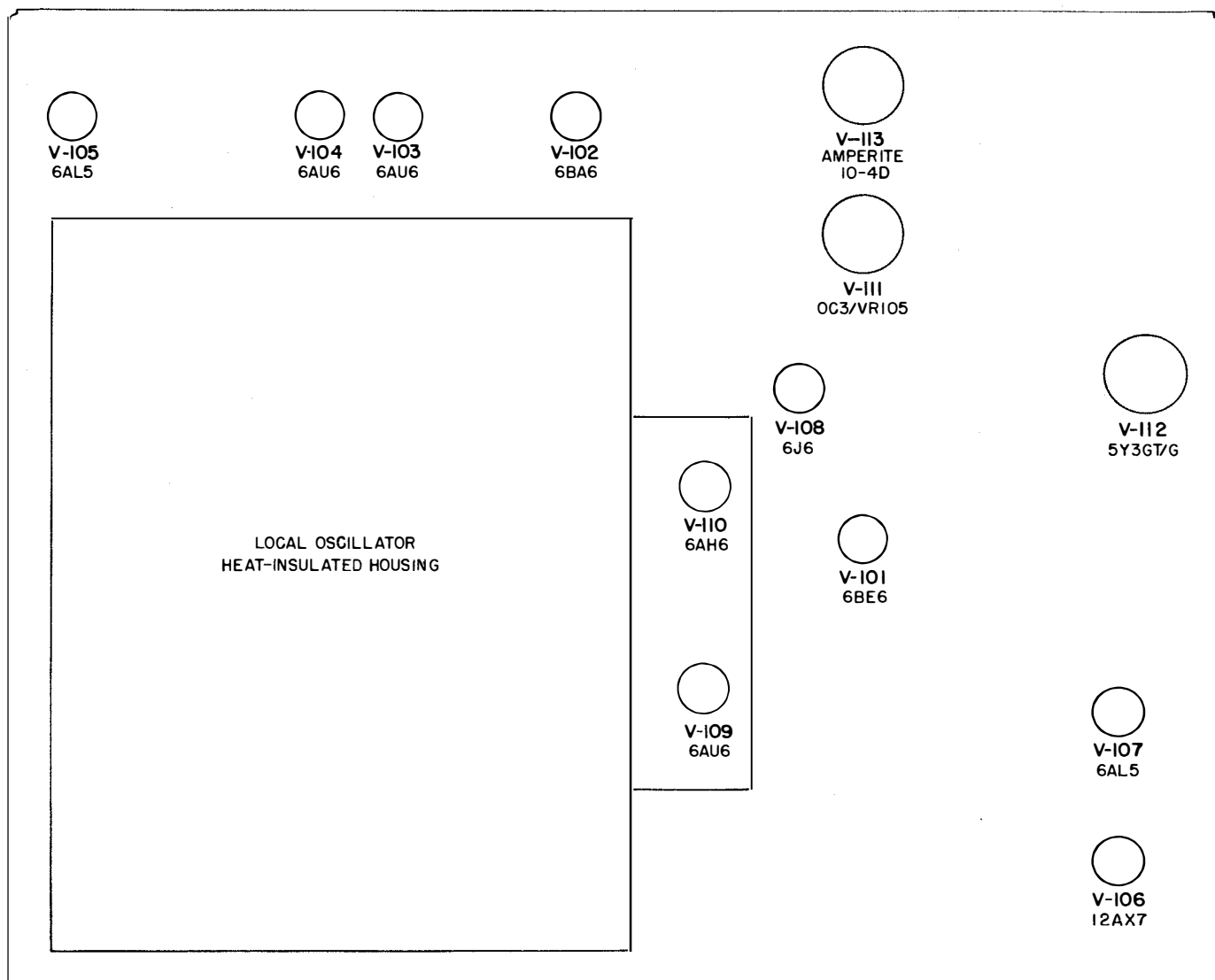

Figure 5-1. RF Monitor, Tube Location Diagram

burned out. Inspect the fuses by unscrewing the front panel fuse holders. If the fuses show signs of burn-out, replace with one of the spare fuses. This should restore the equipment to normal operation. If the fuses do not show any evidences of burn-out, it is well to measure them for continuity on an ohmmeter, and replace as required.

WARNING

Never replace a fuse with one of higher rating unless the continued operation of the equipment is more important than probable damage. If a fuse burns out immediately after replacement, do not replace it a second time until the cause has been corrected.

b. Fuse failure is indicated by total equipment failure. If the fuses are burned-out, the pilot light and

tubes will not be illuminated, even though the POWER switch is on. In addition, the meter will indicate zero reading (left hand zero even in the TUNE position). One or both of the fuses is probably burned-out and should be replaced. If the replacement fuse also burns out, do not attempt to operate the equipment again until the cause of trouble has been located and corrected. If operation is not restored by fuse replacement, it is possible that the power source has failed, and it is wise to check the primary voltage with an a-c voltmeter.

3. TUBE REPLACEMENT DATA.

(See figure 5-1.)

a. Tube failures are responsible for the largest number of failures that occur in equipments of this type. When a tube is suspected as causing faulty op-

eration of the equipment, the tube may be either checked on an approved type tube checker or by replacement with a tube known to be good. Of course in routine maintenance checks, all tubes are checked at regular systematic intervals.

b. When placing a new tube into a circuit, note the position of the equipment controls before making any changes. If resetting the controls with the new tube in the circuit does not correct the abnormal condition, return the controls to their original settings and restore the original tube, unless a tube test made with an approved type tube checker used according to its own instruction data shows the tube to be bad.

Note

All tubes of a given type supplied with the equipment should be consumed prior to employment of tubes from general stock.

c. When replacing a tube in a circuit, decide immediately whether or not to keep the old tube, and do not change tubes indiscriminately; otherwise the spares box will become full of tubes whose exact age and condition is unknown or uncertain. Realignment will sometimes be necessary when new tubes are used to replace the originals. Therefore only replace a tube when it is definitely known to be defective, or when a replacement tube provides proper operation.

d. The octal-based tubes are secured by means of locking clamps at their base. It will be necessary, therefore, to release the locking clamp before the tube can be removed for test or replacement. The other tubes are of the miniature type. To remove the shields from the miniature tubes, the shield is pushed down and given a slight twist counter-clockwise. The tube may then be readily serviced. Be sure to replace the tube shield on each tube so equipped.

4. CALIBRATION CHECKING PROCEDURE.

a. To assure accurate frequency-shift readings as indicated on the meter of the RF Monitor, the internal calibration of the monitor should be checked at periodic intervals. While the equipment maintains its calibration over long periods of time, if highly accurate measurements are to be taken, periodic calibration checks are desirable for reliable readings. The calibration check consists essentially of two parts and is covered below.

(1) Set **E** R.F.GAIN to zero (full counter-clockwise).

(2) Set the **D** TUNE-MEASURE switch to KEYED SIGNAL.

(3) If required, adjust **J** METER ZERO SET for zero reading on the meter (left-hand zero on the upper scale of meter M-101).

b. The above procedure covers the meter zero set adjustment, and the frequency-shift calibration of the meter M-101 is covered below. It is desirable to repeat this check at frequent intervals to assure calibration of the equipment. It is necessary to make a calibration check whenever the equipment is to be used after periods of inactivity, in which case at least five minutes should be allowed for the equipment to reach stable operating temperature, and the meter zero set adjustment, as described above, should be completed first.

(1) Set **C** MONITOR-CALIBRATE switch to CALIB FREQ. A.

(2) Set **D** TUNE-MEASURE switch to TUNE.

(3) Set **B** BAND switch to 1.0—2.9.

(4) Turn **E** R.F. GAIN to full-on position (full-clockwise).

(5) Set **L** TUNING to approximately one mc (refer to the approximate frequency calibration charts).

(6) Adjust **L** TUNING until the meter points to the mid-scale mark after tuning through the signal as indicated by an upward and downward swing on the meter.

(7) Set **D** TUNE-MEASURE to UNKEYED SIGNAL.

(8) Adjust **H** FINE TUNING until meter reads zero (left-hand) on the upper scale.

(9) Set **C** MONITOR-CALIBRATE switch to CALIB FREQ. B.

(10) If necessary, adjust **K** METER CALIB. until the meter indicates 1000 cps on the upper scale of the meter M-101.

c. Normally of course after the initial calibration the equipment will not require continual adjustment. It is good practice, however, to check the calibration at periodic intervals to assure that the maximum accuracy of the equipment is available at all times.

SECTION 6 PREVENTIVE MAINTENANCE

1. GENERAL MAINTENANCE NOTES.

a. The vital purpose of all maintenance work is the insurance that every equipment can be depended upon for satisfactory and uninterrupted operation. The best maintenance is preventive in nature, and potential failures are corrected before they have a chance to develop. This involves not only regular checks and tests of the equipment but a systematic recording of all performance data, voltage, and resistance measurements as well. Week-to-week changes in the performance of the equipment should be small, and any marked deviation should be regarded as a sign of trouble and investigated promptly. Thus, potential troubles may be detected and prevented from developing. The regular test program and the recording of all data enables the maintenance crew to acquire a thorough knowledge of the equipment and available test apparatus so that the whole process of trouble shooting and repair is lightened.

b. All observations and mechanical checks and

tests should be completed before electrical tests are begun and the latter should precede actual trouble shooting. After any repairs and replacements have been made, the equipment should be thoroughly rechecked, visually, mechanically, and electrically, and proven to be in satisfactory operating condition. Preventive maintenance schedules are listed in table 6-1, while actual trouble location and repair procedures are covered fully in Section 7 of this handbook.

2. MAINTENANCE TEST SCHEDULE.

a. The maintenance procedures outlined in the test schedule of table 6-1 are recommended to assure satisfactory performance from the equipment.

Note

The attention of maintenance personnel is invited to the requirements of Chapter 67 of the "Bureau of Ships Manual" of the latest issue.

TABLE 6-1. MAINTENANCE TEST SCHEDULE

Inspection Period	Check	Indication
Weekly.	Pilot lamp.	Pilot Lamp should light when power is applied to the equipment.
	Fuses.	Fuses should be secure in front panel fuse holders.
	Controls and Switches.	Control action should be smooth and continuous, control knobs should be tight on shafts; switch action should be firm and positive.
	Power cord (and r-f input cable, if used).	There should be no evidence of cable insulation failure (frayed, cracked, or split insulation on power cord or r-f input cable), or corrosion or accumulated dirt in or around contacts of connectors or a-c line plug.
	Meter-zero set and calibration procedure.	The equipment should respond properly to the pre-operational calibration procedure given in Section 4.
Monthly.	Operation of E R.F. GAIN control.	Check that limiter saturation is obtained for at least one-quarter turn of the E R.F. GAIN control knob.
	General visual and mechanical (top of chassis) inspection.	The equipment should be removed from its cabinet or from the rack and a general visual check made to see that all tubes are firm in their sockets and that tube shields are properly located. With power applied to the equipment, the heaters or filaments of all tubes should light, and the glow-discharge of the voltage regulator V-111 should be readily apparent as a reddish glow. The ballast tube V-113 should be noticeably warm to the touch. No backlash in the tuning gear train should be present, and the operation of the tuning control should be smooth, free, and noiseless. The three tube clamps should be clamped tightly, and all components should be secure and rigidly mounted, with no evidence of loose hardware.
Semi-Annually.	General visual and mechanical (beneath chassis).	The equipment should be removed from its cabinet or from the rack and a general visual check made on the underside of the chassis to see that no charring or discoloration of any component has occurred. All components beneath the chassis should be secure and rigidly mounted, with no evidence of frayed or discolored wiring insulation at any point, and no traces of transformer or capacitor oil should be present anywhere in the equipment. No indications of corrosion or fungus growth should be apparent.
	Tubes.	All tubes should be checked on an approved tube checker, preferably of the transconductance-measuring, or power-output type to see that all tubes are in satisfactory condition.
	Voltages and Resistances.	Voltage and resistance measurements should be taken at the contacts of all tube sockets, and the results compared with the representative values shown in figure 7-5. Marked variations from these values may be taken as an indication of potential trouble, even though the equipment may appear to be operating normally in all other respects.

b. None of the components of the present equipment have been treated with any fungus or moisture coating, and therefore special precautions in handling the equipment are not required, nor is re-tropicalization necessary.

3. LUBRICATION.

(See figure 6-1.)

a. The bevel, worm, and worm follower gears of the tuning capacitor assembly require lubrication every 200 or 300 working hours. Since these gears are not

in continuous motion, only a very light coating of the lubricating grease should be used to avoid congealing of excessive grease. Apply a light coating of JAN Lubricant AN-G-25 to all the gears in the tuning capacitor assembly, as shown in figure 6-1. The worm and follower gear in the oscillator chamber do not require lubrication, and disassembly of the oscillator chamber is not necessary.

b. Do not lubricate any component other than the tuning gears. Shafts, shaft bearings, or capacitor bearings should not be lubricated.

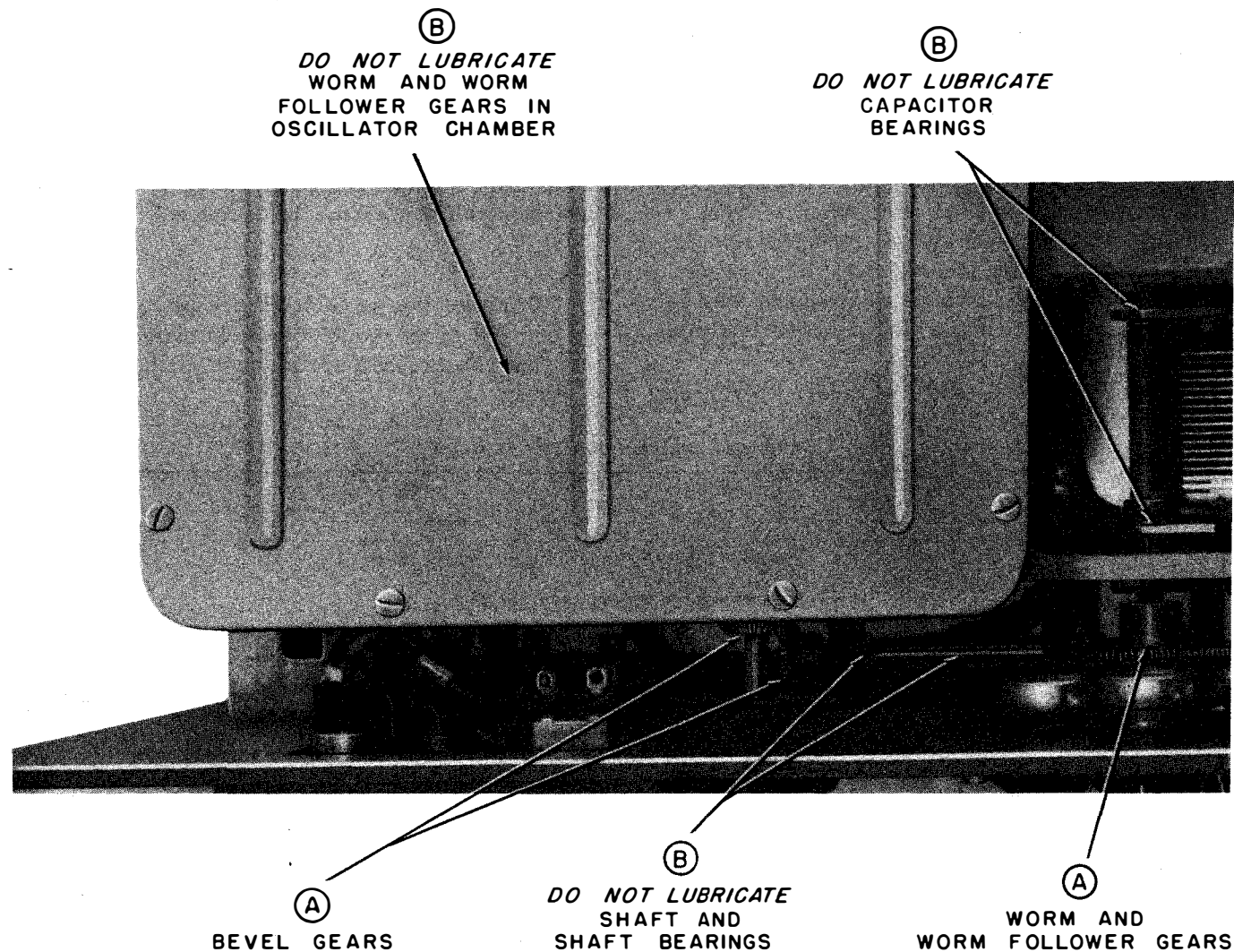

- (A) Apply a light coating of JAN Lubricant AN-G-25 every 200 to 300 working hours. Use only a very light coating to avoid congealing of excessive grease
- (B) Do not lubricate shafts, shaft bearings, or capacitor bearings. Worm and follower gears in the oscillator chamber do not require lubrication

JAN Lubricant			Nearest Commercial Lubricant
Specification		A.S.O. Stock No. 1-LB	
AN-G-25	Lubricating Grease	R14-G-982-20	Beacon #325 Grease

Figure 6-1. Lubrication Data



FAILURE REPORTS

A FAILURE REPORT must be filled out for the failure of any part of the equipment whether caused by defective or worn parts, improper operation, or external influences. It should be made on Failure Report, form NBS-383, which has been designed to simplify this requirement. The card must be filled out and forwarded to BUSHIPS in the franked envelope which is provided. Full instructions are to be found on each card.

Use great care in filling the card out to make certain it carries adequate information. For example, under "Circuit Symbol" use the proper circuit identification taken from the schematic drawings, such as T-103, in the case of a transformer, or R-101, for a resistor. Do not substitute brevity for clarity. Use the back of the card to completely describe the cause

of failure and attach an extra piece of paper if necessary.

The purpose of this report is to inform BUSHIPS of the cause and rate of failures. The information is used by the Bureau in the design of future equipment and in the maintenance of adequate supplies to keep the present equipment going. The cards you send in, together with those from hundreds of other ships, furnish a store of information permitting the Bureau to keep in touch with the performance of the equipment of your ship and all other ships of the Navy.

This report is not a requisition. You must request the replacement of parts through your Officer-in-Charge in the usual manner.

Make certain you have a supply of Failure Report cards, and envelopes on board. They may be obtained from any Electronics Officer.

1. Additional forms and envelopes may be obtained from nearest District Publications & Printing Office or (M 194), USMC, Do not delay submitting this form. Insert it in envelope, seal, mail. No signature is required. Fill in with TYPEWRITER, PEP, or PENCIL.

2. This form supersedes previous versions of NAVY Forms NBS 304 and 303.

3. This form shall be used to report ALL FAILURES (whatever the cause) of electronic equipment, tubes, components, or parts. Report one failure only to a sheet.

4. The In desig
5. If DESIGNS
6. The of Elec
7. Set machine

8. The guarant on a to this de indicat
9. Lat numbers supplie
10. Dis desired length

ELECTRONIC EQUIPMENT FAILURE REPORT
NAVSHIPS 383 (Rev. 3-61)

ORGANIZATION PERFORMING MAINTENANCE

EQUIPMENT INVOLVED USMC OTHER (Specify)

NAVY RADAR SONAR WIRE TOOL TEST POWER MANTY OTHER (Specify)

EQUIPMENT MODEL DESIGNATION SERIAL NUMBER OF EQUIPMENT NAME OF CONTRACTOR CONTRACT NO.

TYPE NUMBER AND NAME OF MAJOR UNIT INVOLVED SERIAL NUMBER OF UNIT CONTRACT OR UNIT PURCHASE ORDER DATE EQUIPMENT INSTALLED

THIS SIDE FOR TUBES SERIAL NO. (NOTE 8)

TUBE TYPE, INCLUDING PREFIX LETTERS CONTRACT NO. (NOTE 8)

TUBE MANUFACTURE GUARANTEED HOURS (NOTE 8) UNIT OF ACCEPTANCE (NOTE 8)

FAILURE OCCURRED IN OPERATION ACTUP HOURS DATE OF FAILURE

STORAGE OTHER (Specify in Remarks) TYPE OF FAILURE (NOTE 1) TUBE CIRCUIT SYMBOL

HANDLING

INSTALLING

NATURE OF FAILURE AND REMARKS (See 10 - Continue on back)

ITEM WHICH FAILED

THIS SIDE FOR PARTS (NOTE 9)

NAME OF PART SERIAL NO. CONTRACT DATA *DATE RECEIVED *PART STOCK NO.

*CHECK-OFF OF TAG DATA (NOTE 9) *MANUFACTURER'S DATA (NOTE 9)

BRIEF DESCRIPTION AND CAUSE OF FAILURE, INCLUDING APPROXIMATE LIFE (CONTINUE ON BACK)

REPORT NO. _____ DATE _____

NAME AND DATE OF PERSON MAKING REPORT

10392

*Not required for reports submitted by Naval Activities

Figure 7-1. Failure Report, Sample Form

SECTION 7

CORRECTIVE MAINTENANCE

1. MAINTENANCE PROCEDURES.

a. Before attempting to service the RF Monitor of the OCT-2 or OCT-3 equipments, maintenance personnel should be familiar with the operating precautions and procedures and the detailed theory of operation of its various circuits. Follow the procedures outlined in this section in order to obtain maximum performance from the equipment.

b. Actual procedures required to maintain this equipment in satisfactory condition are preceded by general notes on trouble shooting. The common trouble symptoms, causes, and remedies that may be encountered in the field are also summarized. The schematic diagram of figure 7-6 should be referred to throughout the servicing procedures.

2. GENERAL NOTES ON TROUBLE SHOOTING.

a. **GENERAL.**—The first step in servicing any type of equipment is to sectionalize the fault. *Sectionalization* means tracing the fault to a particular unit of the equipment being serviced. The second step is to localize the defect. *Localization* means tracing the fault to a specific stage or functionally related group of stages within the unit in which the fault seems to originate. The final step is to isolate the fault. *Isolation* means tracing the fault to the particular circuit component specifically responsible for the defective operation of the equipment, following which the necessary repairs or replacements are effected. Some faults such as burned-out or overloaded resistors, can be immediately located by sight, smell, or hearing, and since these are the quickest and least tedious of tests, they are the first to be applied. The less apparent faults, however, must be located by checking voltages and resistances, and comparing input and output waveforms of the various stages. Unfortunately this type of fault is found to occur in the majority of cases where abnormal operation is found to occur.

b. **OBJECTIVES.**—When the results of the procedures outlined in the maintenance test schedule of table 6-1 or when actual operation of the equipment discloses that the equipment is not functioning properly, it becomes necessary to correct any defects as quickly and efficiently as possible. Of course, if the equipment should not operate at all, or should the cause of any trouble be doubtful or unknown, it is then necessary to determine the source of trouble before any repairs can be made.

c. **BASIC CONSIDERATION.**—The most obvious sources of trouble, and the ones most easily corrected are defective tubes. Other points to check before extensive trouble shooting procedures are started are improper line and internal-supply voltages. If previous tests indicate voltage readings not in conformance within specified limits, these are the first corrections to be made. If the equipment still operates improperly with a corrected voltage supply, it is then necessary to locate and remove the cause of the trouble. Where the source of the trouble is not definitely known, it is usually possible, by means of preliminary signal tracing, to track the difficulty down to a particular stage or functional group of stages. A test signal is injected into the equipment and its course traced by means of waveforms and voltage measurements taken at the various key points. By a process of elimination, the particular stage or stages which are functioning abnormally may be determined.

d. **REPETITION OF TESTS.**—It is possible that other troubles may have been introduced during repair or replacement of a defective component; or equipment characteristics may have radically altered; or circuit components other than the particular one repaired or replaced may have been defective. Due to the abnormal operation of the defective stage itself, other symptoms of failure may have gone unnoticed. It is for these reasons that after all known defects have been repaired, the equipment should be subjected to performance tests to see that it meets specified limits. If further troubles are indicated it is necessary to repeat the entire sequence until specified limits are met.

e. **OBSERVATIONAL CHECKS.**—When trouble is encountered, a visual check should be made on as much of the equipment as is readily accessible, checking plug and receptacle contacts to see that they are clean and establishing good electrical contact, and that no parts of the cable are frayed or otherwise damaged. Also check that cable plugs are inserted fully into their receptacles. Similarly it is wise practice to inspect closely for signs of smoke emanating from within, as well as for the tell-tale odors usually associated with overloaded components. If any such indications are present, turn the equipment off immediately, and do not attempt to turn it on again until the defective components have been located and repaired or replaced.

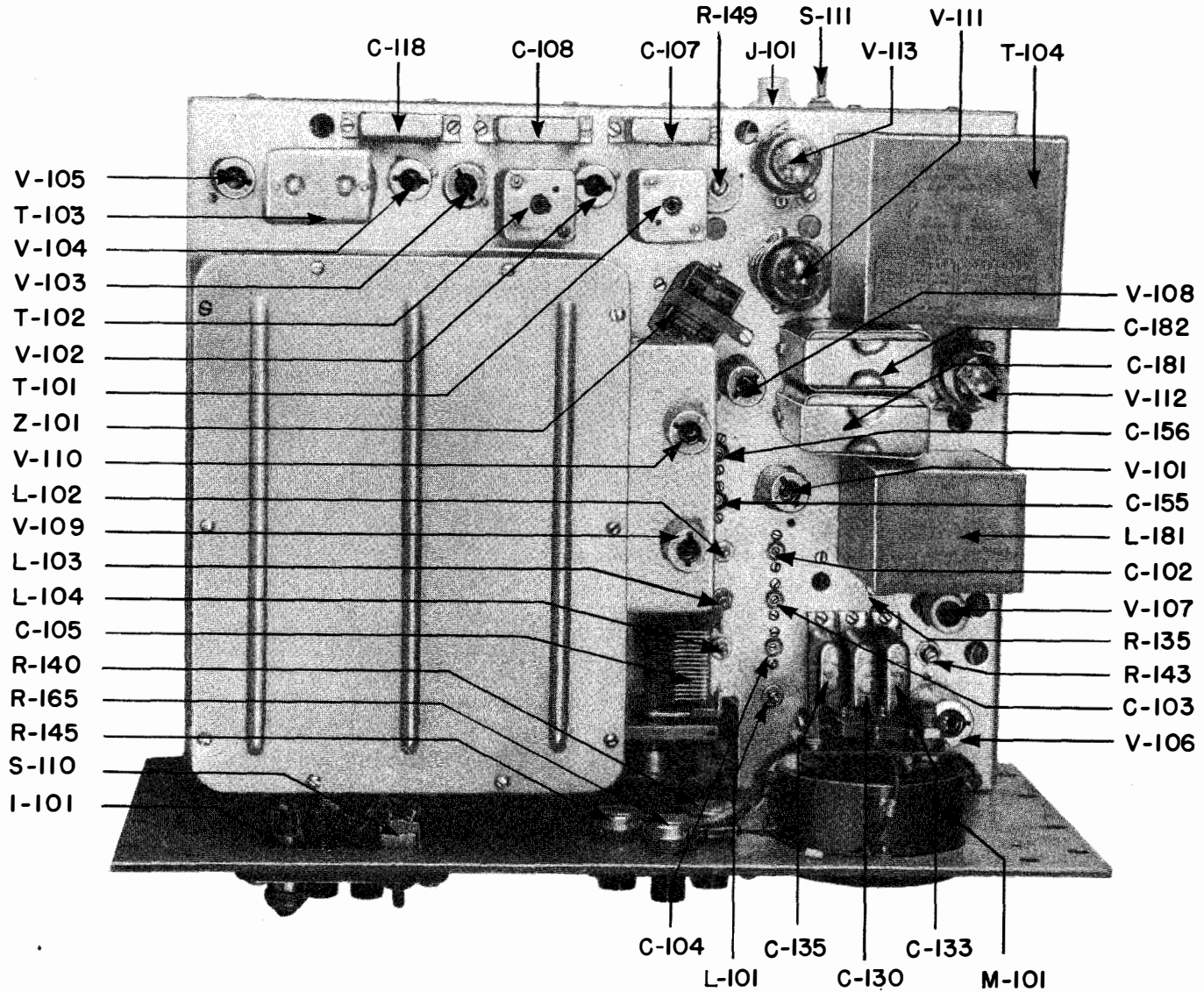

Figure 7-2. RF Monitor, Top View of Chassis

3. EQUIPMENT DISASSEMBLY INSTRUCTIONS.

a. Disassembly of Frequency Shift Monitors OCT-2 and OCT-3 is a very simple procedure. The panel and chassis of Frequency Shift Monitor OCT-2 may be removed from its shock-mounted cabinet by removing the eight machine screws which secure the panel to the cabinet. The tubes and other components may now be readily serviced.

b. Frequency Shift Monitor OCT-3 is disassembled in a somewhat similar manner. The eight panel mounting machine screws should be removed to disassemble the equipment from its rack. In addition, the dust cover wrap-around must be removed to gain access to the tubes and other components mounted above and below the chassis. Loosen the four Dzus fasteners on

the rear of the wrap-around and slide the dust cover off of the panel and chassis.

4. TROUBLE ISOLATION AND REPAIR.

a. When cause of abnormal operation has been traced to a particular stage or to functionally related group of stages, as a result of preliminary testing or of signal tracing procedures, it must be further isolated to a particular component or group of components. To do this it is necessary to disassemble the equipment. After disassembly, the trouble may be immediately apparent through a mere visual inspection (see figures 7-2 and 7-3), whereupon the trouble should be corrected by repair or replacement. If the trouble is not immediately apparent, a more detailed procedure is

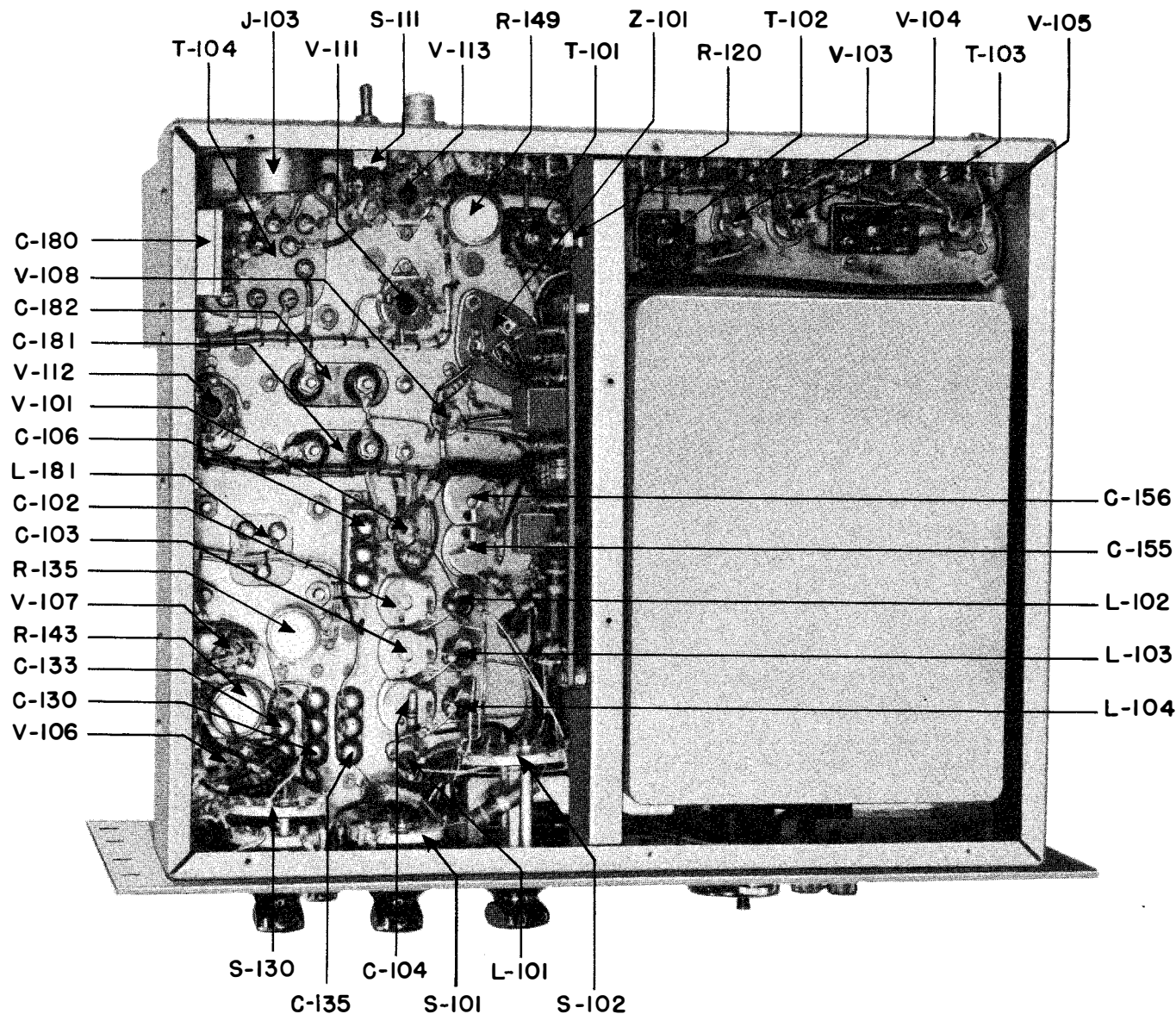

Figure 7-3. RF Monitor, Bottom View of Chassis

followed to repair or replace the actual circuit component responsible for the failure. This procedure consists of tube checks, point-by-point resistance and voltage checks, and finally, repair or replacement of the defective component.

b. **TUBE CHECKING.**—Tube failures are responsible for the largest number of failures that occur in equipments of this type. When putting a new tube into a circuit, note the position of the equipment controls before making any changes. If resetting the controls with the new tube in the circuit does not correct the abnormal condition, return the controls to their original position and restore the original tube, unless a tube test made with an approved type tester used according to its own instruction data shows the tube to be bad.

Note

All tubes of a given type supplied with the equipment should be consumed prior to employment of tubes from general stock.

c. **RESISTANCE MEASUREMENTS.**—When a particular stage has been observed to be operating improperly, the defective component can usually be located by measurement of the ohmic resistance between the various points in the circuit and a reference point or points (usually ground), since when a fault develops in a circuit, its effect will very often show up as a change in the resistance values. The representative resistance values listed in figure 7-5 may be used to advantage in isolating defective components. These

values, unless otherwise stated, are measured between the tube pin indicated and ground.

(1) Before making resistance measurements, turn off the power. An ohmmeter is essentially a low range voltmeter and battery. If the ohmmeter is connected to a circuit which has voltages on it, the needle may be deflected off scale and the meter may be permanently damaged.

(2) Capacitors must always be discharged before resistance measurements are made. This is very important in the case of power supplies that are disconnected from their loads. The discharge of the capacitor through the meter may burn out its movement and in some cases may endanger life.

d. VOLTAGE MEASUREMENTS.—Voltage measurements are an indispensable aid to the repairman, because most troubles result either from abnormal voltages or produce abnormal voltages. Voltage measurements can be made easily, since they are always made between two points in a circuit and circuit operation need not be interrupted.

(1) Information on the normal operating voltages is given in figure 7-5. These voltages are measured between the indicated points and ground, unless otherwise stated.

(2) It is good practice to set the voltmeter on its highest range, so that any abnormal voltages existing in a circuit will not overload it. Then if it is necessary to obtain increased accuracy, the voltmeter may be set to the designated range for comparison with the representative value given in figure 7-5.

(3) Remember that voltage readings can be obtained even when a resistor is open. The resistance of the meter may act as the circuit-resistance. Thus the voltage may be approximately normal only as long as the voltmeter is connected. Before the voltage is measured, a resistance check should be made to determine if circuit resistance is normal.

(4) Certain precautions must be followed when measuring voltages above a few hundred volts. High voltages are dangerous and can be fatal. When it is necessary to measure high voltages, observe the following rules:

(a) Connect the ground lead to the voltmeter first.

(b) Place one hand in a pocket.

(c) If the voltage is less than 300 volts (as in the case of the present equipment), connect the test lead to the point to be measured. The test point may be either positive or negative with respect to ground.

(d) If the voltage is greater than 300 volts, shut off the power, connect the proper test lead, step

away from the voltmeter, turn on the power, and note the reading on the voltmeter. Do not touch any part of the voltmeter while the power is on, particularly when it is necessary to measure the voltage between two points both of which are above ground potential. In this connection, it should be noted that there are several critical measurements indicated in figure 7-5. The notes and conditions for measurement should be carefully observed to avoid erroneous readings. Most of the voltage measurements are accurate for either 1000 or 20,000 ohms/volt meters. However, several measurements require the use of only a 20,000 ohm/volt meter, such as Navy Model OE Series, or equivalent. It should be observed that the V-106 grid and V-107 plate voltage measurement requires the use of a vacuum-tube-voltmeter with at least 10 megohms input resistance. If a 1000 or 20,000 ohm/volt meter were used for these measurements, the loading would be so excessive that the readings would be meaningless.

5. SERVICING THE LOCAL OSCILLATOR.

(See figure 7-4.)

a. Ordinarily the local oscillator heat-insulated chamber will never require disassembly, since only the frequency-determining components of the local oscillator are housed inside the chamber. The local oscillator and frequency multiplier tubes V-109 and V-110 are mounted externally to the chamber to facilitate tube replacement. However, if it is ever found necessary to service any components located within the insulated chamber (C-160, C-161, or L-160), it is important that the proper procedure, as described below, be followed.

b. The local oscillator heat-insulated chamber is comprised of two sections. To disassemble the chamber, first remove the ten machine screws holding the top cover in place. When this top cover is removed, the inner-section cover is exposed. Remove the ten screws holding the inner cover in place, and thread two 8-32 screws into the two holes on the top of the inner cover. By means of the two 8-32 screws, lift the inner cover away from the chamber. The oscillator components (C-160, C-161, and L-160) may now be readily serviced.

c. The oscillator chamber should be re-assembled very carefully. Make sure that the insulation attached to the top cover makes a snug fit with the insulation in the chamber shell. Trouble within the oscillator chamber is highly unlikely, and a principal reason for illustrating the internal construction in figure 7-4 is to indicate to interested personnel the features of the local oscillator chamber without actually requiring the chamber to be disassembled.

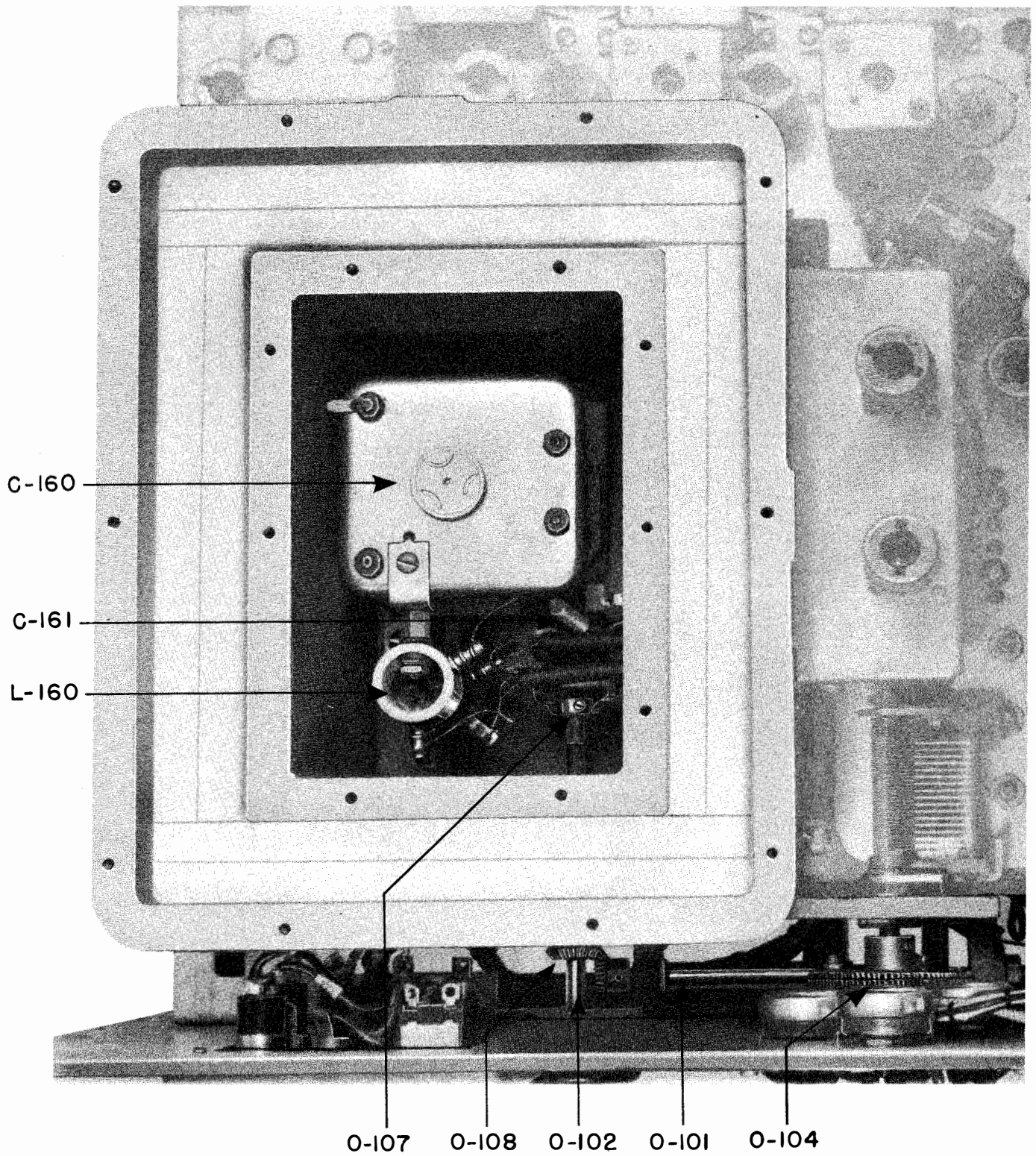

Figure 7-4. Servicing the Local Oscillator

6. TROUBLE SYMPTOMS, CAUSES, AND REMEDIES.

(See figures 7-5 and 7-6.)

a. A summary of the probable trouble symptoms, causes, and remedies is presented in table 7-1. These are the most likely troubles to be encountered in the field; however, it should be realized that all possible troubles cannot be covered, and for other cases of defective operation, the trouble shooter should resort

to signal tracing procedures and voltage and resistance measurements as shown in figure 7-5.

b. The calibration check, covered in Section 4 of this instruction book, provides an excellent quick-check on equipment performance. If any component is repaired or replaced, a satisfactory calibration check indicates that proper operation has been restored; however the more complete bench-check tests, as covered in table 7-2, should be completed before the equipment is restored to operation.

TABLE 7-1. TROUBLE SYMPTOMS, CAUSES, AND REMEDIES

Trouble Symptom	Probable Location	Suggested Remedy
Pilot lamp fails to light.	Pilot light. Fuses. Line cord. Power switch.	Replace if defective. Replace if defective. Replace or repair if defective. Replace if defective.
Inability to "zero set" meter in "keyed" operation.	V-106, V-107. Circuit components.	Check and replace if defective. Check voltages and resistances.
No zero coincidence in "keyed" and "unkeyed" operation.	V-105, V-106, V-107. Servicing adjustment misalignment. Circuit components.	Check and replace if defective. Repeat complete zero-set servicing procedure given in Section 7. Check voltages and resistances.
No signal during self-calibration on Calib. Freq. A.	V-108 (Freq. A half). Z-101A (Freq. A half).	Check for presence of Calib. Freq. B.
Calib. Freq. B gives indication but no signal on Calib. Freq. A.	V-108 (Freq. A half). Z-101A (Freq. A half).	Check and replace if defective.
No signal during self-calibration on Calib. Freq. A or Calib. Freq. B.	Z-101. V-108, V-109, V-110. V-101, V-102, V-103, V-104. S-101. Circuit components.	Check by replacement. Check and replace if defective. Check and replace if defective. Clean contacts if required. Check voltages and resistances.
Equipment badly off calibration.	Mechanical alignment.	Check and readjust if required.
Unstable zero on Calib. Freq. A or Calib. Freq. B.	V-109.	Replace tube.
Inability to calibrate meter at 1000 cps (equipment not limiting).	V-108, V-101, V-102, V-103, V-109, V-110. Z-101. Circuit components.	Check in order and replace if defective. Check by replacement Check voltages and resistances.
Inability to calibrate meter at 1000 cps (equipment limiting).	V-106. V-103, V-104. Limiters and voltmeter stages. R-120 not properly adjusted. Discriminator misaligned.	Remove power and check, replacing if required, then apply power again. CAUTION: V-106 should not be removed from its socket unless power is first removed from the equipment. Check and replace if defective. Check voltages and resistances in these stages (V-103, V-104, and V-106). Readjust in accordance with alignment procedures given in Table 7-2. Realign in accordance with alignment procedures given in Table 7-2.
Voltage regulator V-111 fails to light.	V-111, V-112. T-104 secondary 5-6.	Check and replace if defective. Check and replace transformer if necessary.

TABLE 7-2. BENCH-CHECK TESTS AND ALIGNMENT PROCEDURES

Ground the RF Monitor and associated test equipment before applying power. Space connecting test leads adequately from the equipment in order to avoid possible oscillation.

Step	RF Monitor	Test Procedure
<p>I. Power Supply Check</p>	<p style="text-align: center;"><i>Summary</i></p> <p>A check is made on the operation of the power supply with the lowest a-c input voltage normally to be encountered in the field.</p> <p>4. Examine V-111 (OC3/VR-105) to see that it is conducting. If so, proceed directly to step 9.</p> <p>5. If V-III is not conducting, replace with new OC3/VR-105.</p> <p>6. If V-III still does light, replace V-112 (5Y3GT/G).</p> <p>7. Check to see that the voltages at the socket of V-112 are correct (see figure 7-5).</p> <p>8. If V-111 still does not light, a complete check of tube socket voltages and resistances becomes necessary (see figure 7-5) to localize and correct the fault.</p>	<p style="text-align: center;"><i>Equipment Required</i></p> <p>Variac capable of zero to 135 volt operation at one ampere output with 115 volts a-c, 60 cps, single phase input. A-c voltmeter having approximately 130-volt scale. A-c voltmeter having approximately 10-volt scale.</p> <p>1. Connect the variac and the 130-volt a-c meter so as to control and measure the input voltage applied to the equipment.</p> <p>2. Apply power to the equipment with the variac set to zero.</p> <p>3. Bring the variac slowly up to 103 volts, and allow at least 30 seconds for warm-up.</p> <p>9. Connect the 10-volt a-c voltmeter from pin #3 to pin #4 of V-107 (6AL5).</p> <p>10. Bring the variac slowly up to 115 volts.</p> <p>11. The voltmeter reading obtained in step 9 above should not change by more than 0.2 volt.</p>
<p>II. Local Oscillator Frequency Check</p>	<p style="text-align: center;"><i>Summary</i></p> <p>The equipment local oscillator frequency is checked on an oscilloscope against a standard signal generator at two points within its range.</p> <p>1. Using a 1000 $\mu\mu\text{f}$ 600-volt series capacitor and an unshielded wire lead, connect pin #5 (plate) of local oscillator V-109 (6AU6) to the vertical input of the oscilloscope.</p> <p>5. Set L TUNING accurately to zero.</p>	<p style="text-align: center;"><i>Equipment Required</i></p> <p>Signal generator with output control, capable of tuning from approximately 900 kilocycles to 24 megacycles. Oscilloscope or synchroscope having at least a four-megacycle pass-band.</p> <p>2. Connect the output of the signal generator through a 1000 ω to 10,000 ω ($\frac{1}{2}$ watt) series resistor to the vertical input of the oscilloscope.</p> <p>3. Turn signal generator output to zero.</p> <p>4. Put oscilloscope on slowest sweep.</p> <p>6. Tune signal generator to 1.84 megacycles.</p> <p>7. Increase signal generator output until oscilloscope pattern increases in amplitude approximately 30%.</p> <p>8. Carefully tune signal generator until zero beat with the local oscillator frequency is indicated on the oscilloscope (sinusoidal appearance of top and bottom edges of pattern near zero beat with decreasing envelope frequency as zero beat is approached).</p>

TABLE 7-2. BENCH-CHECK TESTS AND ALIGNMENT PROCEDURES—Continued

Step	RF Monitor	Test Procedure
II. Local Oscillator Frequency Check Continued	10. Set L TUNING carefully to 90.	9. Zero beat with the local oscillator frequency should occur at $1.87 \pm .01$ megacycles. 11. Zero beat signal generator with local oscillator frequency as in 9 above. 12. Zero beat with the local oscillator frequency should occur at $3.85 \pm .01$ megacycles.
III. Alignment of Discriminator Transformer (T-103)	<p style="text-align: center;"><i>Summary</i></p> <p>With a 912-kc signal applied to the grid of the first limiter, the secondary of T-103 is detuned and the primary tuned for maximum response. Then the secondary is adjusted to give zero d-c discriminator output.</p> 1. Using an insulated screwdriver, turn secondary trimmer of T-103 (marked #2) until red dot on shaft is aligned with red dot on can. 6. Adjust primary trimmer of T-103 (marked #1) for maximum voltmeter reading, adjusting signal generator output to give approximately 1/2-scale reading (about 50 volts). 10. Adjust secondary trimmer of T-103 (marked #2) in a counter-clockwise direction until voltmeter reading increases and then goes through zero. This zero is the correct tuning point.	<p style="text-align: center;"><i>Equipment Required</i></p> <p>Signal generator with calibrated output control, capable of tuning from approximately 900 kilocycles to 24 megacycles. D-c voltmeter having 20,000 ohms/volt, or greater, sensitivity.</p> 2. Connect the positive lead of the voltmeter to the ungrounded terminal of C-127. 3. Set the voltmeter to 100-volt scale. 4. Connect the negative voltmeter lead to the bottom (cold) end of L-125. 5. Connect signal generator output to pin #1 (grid) of V-103 (6AU6), and tune the signal generator to 912 kc. 7. DO NOT shift signal generator frequency or output from this point on. 8. Remove voltmeter leads and reconnect negative lead to ungrounded terminal of C-127. 9. Connect positive voltmeter lead to pin #2 (grid) of V-106 (12AX7).
IV. Alignment of I-F Amplifier (T-101) and Limiter (T-102)	<p style="text-align: center;"><i>Summary</i></p> <p>With a 912-kc signal applied to the grid of the i-f amplifier, the primary and secondary of T-102 are aligned. The 912-kc signal is then shifted to the signal grid of the mixer and the primary and secondary of T-101 are aligned.</p> 5. Turn E R. F. GAIN fully clockwise.	<p style="text-align: center;"><i>Equipment Required</i></p> <p>Same as Step III above.</p> 1. Connect the positive lead of the voltmeter to the ungrounded terminal of C-127. 2. Set voltmeter to 100-volt scale. 3. Connect the negative voltmeter lead to the bottom (cold) end of L-125. 4. Connect signal generator output to pin #1 (grid) of i-f amplifier V-102. 6. Set signal generator at 912 kilocycles and adjust output to give approximately 1/2-scale reading (about 50 volts).

TABLE 7-2. BENCH-CHECK TESTS AND ALIGNMENT PROCEDURES—Continued

Step	RF Monitor	Test Procedure
<p>IV Alignment of I-F Amplifier (T-101) and Limiter (T-102) Continued</p>	<p>7. Adjust secondary of T-102 (top slug) for maximum voltmeter reading, keeping signal generator output adjusted as in step 6 above.</p> <p>8. Adjust primary of T-102 (bottom slug) for maximum voltmeter reading, keeping signal generator output adjusted as in step 6 above.</p> <p>9. Remove local oscillator tube V-109 from its socket.</p> <p>10. Turn B BAND to 1.0—2.9.</p> <p>12. Tune secondary of T-101 (top slug) for maximum voltmeter indication, keeping signal generator output adjusted as in step 6 above.</p> <p>13. Tune primary of T-101 (bottom slug) for maximum voltmeter indication, keeping signal generator output adjusted as in step 6 above.</p> <p>14. Replace V-109.</p>	<p>11. Connect signal generator output to pin #7 (signal grid) of mixer V-101.</p>
<p>V. Input Tuning Alignment and Sensitivity Check</p>	<p style="text-align: center;">Summary</p> <p>On the lowest equipment tuning band, the input tuning circuits are adjusted for exact tracking at the mid-frequency of the band. On the remainder of the bands, exact tracking adjustments are made at two points within each band. The substantially straight-line-frequency tuning of both the local oscillator and the input circuits then produces only a negligible tracking error over the remainder of any band.</p> <p>4. Set B BAND to 1.0—2.9.</p> <p>6. Tune equipment to signal generator output with the aid of the frequency calibration charts supplied (see also figures 4-2 and 4-3).</p> <p>8. Adjust L-101 tuning slug for maximum voltmeter reading, keeping signal generator output adjusted as in step 7 above.</p> <p>An overall equipment sensitivity check is conveniently made at this point. The following steps indicate the procedure.</p> <p>12. Set B BAND to 2.9—6.7.</p>	<p style="text-align: center;">Equipment Required</p> <p>Same as Step III above.</p> <p>1. Connect output of signal generator to input jack J-101 of the equipment by means of coaxial cable with appropriate connector (Navy type 49195 plug).</p> <p>2. Leave voltmeter connected as in step IV above.</p> <p>3. Set voltmeter to 100-volt scale.</p> <p>5. Tune signal generator to 1.8 megacycles.</p> <p>7. Adjust signal generator output to give approximately 1/2-scale voltmeter reading (about 50 volts).</p> <p>9. Set voltmeter to 300-volt scale.</p> <p>10. Slowly increase signal generator output to limiting threshold (point where voltmeter reading no longer increases for increasing signal generator output).</p> <p>11. Note reading of signal generator output control. This gives sensitivity of equipment. Equipment sensitivity should be six millivolts (55 db below one volt, open circuit) or less.</p> <p>13. Tune signal generator to 3.5 megacycles.</p>

TABLE 7-2. BENCHCHECK TESTS AND ALIGNMENT PROCEDURES—Continued

Step	RF Monitor	Test Procedure
<p>V.</p> <p>Input Tuning Alignment and Sensitivity Check Continued</p>	<p>14. Tune equipment to signal generator output with the aid of the frequency calibration charts supplied (see also figures 4-2 and 4-3).</p> <p>16. Adjust L-102 for maximum voltmeter reading, keeping signal generator output adjusted as in step 15 above.</p> <p>18. Repeat steps 14 and 15 above.</p> <p>19. Adjust C-102 for maximum voltmeter reading, keeping signal generator output adjusted as in step 15 above.</p> <p>20. Repeat steps 13 through 19 above until no further adjustment of either L-102 or C-102 is required.</p> <p>21. The alignment of the input tuning circuits for the two remaining bands is accomplished in the manner outlined in steps 12 through 20 above. For the 6.7—14 megacycle band, L-103 is adjusted at 7.5 megacycles and C-103 at 13 megacycles, while for the 14—26 megacycle band, L-104 is adjusted at 15 megacycles and C-104 at 24 megacycles.</p>	<p>15. Reduce signal generator output to give approximately 1/2-scale voltmeter reading (about 50 volts).</p> <p>17. Tune signal generator to 6.0 megacycles.</p>
<p>VI.</p> <p>Calibrating Oscillator Adjustment</p>	<p style="text-align: center;">Summary</p> <p>With the equipment tuned to one of its crystal-controlled self-calibrating frequencies, an external signal is injected at the mixer, producing a beat note at the discriminator load which may be displayed on an oscilloscope. After tuning the injected signal to zero-beat with the crystal frequency, the other crystal frequency is adjusted for a 1000-cycle beat note with the injected signal.</p> <ol style="list-style-type: none"> 1. Set (B) BAND to 1.0—2.9. 2. Set (C) MONITOR-CALIBRATE to CALIB. FREQ. A. 3. Set (E) R. F. GAIN fully clockwise. 4. Set (D) TUNE-MEASURE to TUNE. <ol style="list-style-type: none"> 7. Connect bottom (cold) end of L-125 to vertical input of oscilloscope. 8. Fully mesh C-155. 9. Tune equipment to frequency A with the aid of the frequency calibration charts supplied or figures 4-2 and 4-3. 11. Set (C) MONITOR-CALIBRATE to CALIB. FREQ. B. 12. Adjust C-156 to obtain a 1:1 lissajou pattern on the oscilloscope. If this adjustment is not possible, perform steps 13, 14, 15, and 16, below. 13. Fully mesh C-156. 15. Set (C) MONITOR-CALIBRATE to CALIB. FREQ. A. 16. Adjust C-155 to obtain a 1:1 lissajou pattern on the oscilloscope. 	<p style="text-align: center;">Equipment Required</p> <p>Standard signal generator with output control, capable of tuning from 900 kilocycles to 24 megacycles. Audio frequency oscilloscope. 1000-cycle standard audio oscillator.</p> <ol style="list-style-type: none"> 5. Clip signal generator output to either side of R-101. 6. Connect output of 1000-cycle standard audio oscillator to horizontal input of oscilloscope. 10. Tune signal generator slowly back and forth about one megacycle until an audio note appears on the oscilloscope. Tune signal generator carefully for zero beat, as indicated by a flattening-out of the oscilloscope pattern into a straight line. 14. Tune signal generator to zero beat with frequency B.

TABLE 7-2. BENCH-CHECK TESTS AND ALIGNMENT PROCEDURES—Continued

Step	RF Monitor	Test Procedure
<p>VII. Zero Set Adjustments</p>	<p style="text-align: center;">Summary</p> <p>With no signal input to the equipment, servicing adjustments of R-135 and R-149 are made.</p> <ol style="list-style-type: none"> 1. Set (C) MONITOR-CALIBRATE to MON. 2. Set (E) R. F. GAIN fully counter-clockwise. 3. Set (D) TUNE-MEASURE to KEYED SIGNAL. 4. Adjust (J) METER ZERO SET for exactly zero indication on frequency-shift meter M-101. 5. Set (D) TUNE-MEASURE to UNKEYED SIGNAL. 6. Adjust R-135 (Meter Zero Unkeyed) for exactly zero indication on equipment meter M-101. 7. Set (D) TUNE-MEASURE to TUNE. 8. Adjust R-149 (Tune Mark Adjust) for exactly center-scale (TUNE) indication on the frequency-shift meter M-101. 	
<p>VIII. Calibration of Measuring Circuits</p>	<p style="text-align: center;">Summary</p> <p>A standard frequency-shift signal having a frequency deviation of 1000 cps, keyed at a speed of approximately 20 cps, is coupled into the equipment. After a check of the oraul monitoring circuit, the automatic keying of the frequency shift standard keyer is switched off, and with manual switching from mark to space frequencies, the final servicing adjustments, R-120 and R-143, are made.</p>	<p style="text-align: center;">Equipment Required</p> <p>Frequency shift standard keyer.</p> <p>Audio keying oscillator for keyer.</p> <p>Receiver with BFO and speaker, capable of tuning to output of frequency shift standard keyer.</p> <p>Audio frequency oscilloscope.</p> <p>1000-cps standard audio oscillator.</p> <ol style="list-style-type: none"> 1. Connect 1000-cps standard audio oscillator output to horizontal input of oscilloscope. 2. Connect audio output of receiver (across speaker leads) to vertical input of oscilloscope. 3. Connect two unshielded insulated wires to the antenna terminal of the receiver. Hang one of these wires near the underside of the socket of Z-101, and support the other near the output terminal of the frequency shift standard keyer. There should be just sufficient coupling to these equipments to ensure adequate signal-to-noise ratio at the receiver. 4. Turn receiver BFO on, AVC off. 5. Adjust keying oscillator to 20 cps. 6. Adjust frequency shift standard keyer to obtain sharpest keying wave-form. 7. Tune receiver to frequency shift standard keyer. Two audio tones will be heard in the speaker. These represent the audio beat notes between the receiver BFO and the mark and space frequencies of the keyer, respectively. 8. Carefully zero-beat the receiver BFO with one of these tones, using the bandsread tuning control for accuracy. When this is done, only one tone will be heard in the speaker and a horizontal line will appear on the oscilloscope. 9. Adjust the frequency-shift control of the keyer until the pattern on the oscilloscope alternately becomes an ellipse. This pattern will not be stationary, but it will be recognizable as a 1:1 frequency-ratio pattern. 10. Note the amount that the frequency-shift control had to be adjusted in step 9, and back off one-half this amount.

TABLE 7-2. BENCH-CHECK TESTS AND ALIGNMENT PROCEDURES—Continued

Step	RF Monitor	Test Procedure
<p>VIII. Calibration of Measuring Circuits, Continued</p>	<p>12. Set E R. F. GAIN fully clockwise.</p> <p>13. Set D TUNE-MEASURE on TUNE.</p> <p>14. Set C MONITOR-CALIBRATE to MON.</p> <p>15. Set F AUDIO GAIN fully clockwise.</p> <p>16. Check D METER ZERO SET to make sure the adjustment made in step VIII above has not been disturbed.</p> <p>17. Tune equipment to keyer frequency with the aid of the frequency calibration charts supplied (or figures 4-2 and 4-3).</p> <p>18. Plug a pair of headphones into C PHONES and listen for the 20-cps keying transients.</p> <p>19. Set D TUNE-MEASURE to KEYED SIGNAL. Frequency-shift meter M-101 should read up-scale.</p> <p>20. Turn E R. F. GAIN slowly counter-clockwise while watching equipment meter. There should be no change in indication until the limiting threshold is reached. This point should be at least one-quarter turn from the fully clockwise position.</p> <p>21. Turn K METER CALIB. 30 degrees clockwise from its center position.</p> <p>22. Adjust R-120 (Limiter Output) for exactly 1000-cps indication on equipment meter M-101.</p> <p>24. Set C MONITOR-CALIBRATE to UNKEYED SIGNAL.</p> <p>25. Tune equipment to keyer space frequency (equipment meter indication exactly zero).</p> <p>27. Adjust R-143 (Meter Sensitivity Unkeyed) for exactly 1000-cps indication on the meter.</p> <p>The calibration of the equipment measuring circuits is now completed. The following procedure checks agreement between the adjustments made on the internal crystal calibrating oscillators and those made on the measuring circuits.</p> <p>28. Set D TUNE-MEASURE to TUNE.</p> <p>29. Set C MONITOR-CALIBRATE to CALIB. FREQ. A.</p> <p>30. Set B BAND to 1.0—2.9.</p> <p>31. Tune equipment to frequency A.</p> <p>32. Set C MONITOR-CALIBRATE to CALIB. FREQ. B.</p> <p>33. With no other equipment panel control settings disturbed, frequency-shift meter M-101 should indicate 1000 cps ± 10 cps.</p>	<p>11. The adjustment made in step 9 upsets that made in step 8. Repeat steps 8 and 9 as often as necessary until a pattern is obtained which is a combination of a straight line and an ellipse, representing a simultaneous zero beat with one frequency (mark or space), and a 1000-cps beat with the other.</p> <p>23. Set keyer to space, or to a corresponding setting.</p> <p>26. Set keyer to mark, or to a corresponding setting.</p>

TABLE 7-3. WINDING DATA





Symbol Designation	Part No.	Diagram	Winding	Wire Size	Turns	D-c Resistance (Ohms)	D-c Test Voltage (Volts)	Inductance	REMARKS
L-101	A-4663-1		Pri. Sec.	#44E #44E	20 57			10.3 μ h 71.5 μ h	Coils universal-wound in same direction on 1/2" diam permeability-tuned coil form. Each coil .063" cam, 83/54 gears, 2:1 idler. Coils impregnated with Q-MAX and varnished.
L-102	A-4663-2		Pri. Sec.	#27E #27E	4 1/2 25				Coils close-wound in same direction on 1/2" diam permeability-tuned coil form. Coils impregnated with Q-MAX and varnished.
L-103	A-4663-3		Pri. Sec.	#21E #21E	2 1/2 11 1/4				Coils close-wound in same direction on 1/2" diam permeability-tuned coil form. Coils impregnated with Q-MAX and varnished.
L-104	A-4663-4		Pri. Sec.	#21E #21E	1 1/2 4				Coils close-wound in same direction on 1/2" diam permeability-tuned coil form. Coils impregnated with Q-MAX and varnished.
L-115	A-4715-1		Single	#7/44 Litz	99	2.5 \pm 5%		36.5 μ h \pm 5% at 1.25 Mc	Coil universal-wound on type RCA20BF272J resistor selected for 0.140" \pm 0.008" diam. Use 0.125" cam, 51/75 gears, 1:1 idler. Coil impregnated with Q-MAX and varnished.
L-125, L-131, L-144, L-145	CL-1146		Grouped Single			40 \pm 10%		2.5 mh \pm 10%	Distributed capacitance 1 μ f. May be replaced with any choke coil having comparable characteristics. Current rating 0.050 ampere.
L-160	A-4700		Tapped Single	#25E	38 tap at 8 and 20			31 μ h \pm 1 μ h	Q at 2.0 Mc = 200 \pm 15. Winding pitch 24 turns per inch. Entire coil and form impregnated with Q-MAX.

TABLE 7-3. WINDING DATA—Continued

Symbol Designation	Part No.	Diagram	Winding	Wire Size	Turns	D-c Resistance (Ohms)	D-c Test Voltage (Volts)	Inductance	REMARKS
L-165	A-4715-3		Single	#7/44 Litz	200	7.5 ±5%		180 μh ±5% at 560 kc	Coil universal-wound on type RCA20BF822J resistor selected for 0.140" ±0.008" diam. Use 0.125" cam, 51/75 gears, 1:1 idler. Coil impregnated with Q-MAX and varnished.
L-170	A-4715-4		Single	#34E	28	0.3 ±5%		1.5 μh ±10% at 15 Mc	Coil close-wound in single layer on type RCA20BF272J resistor selected for 0.140" ±0.008" diam. Coil impregnated with Q-MAX and varnished.
L-181	FR-1019		Dual	#31E	2820 each section	170 ±12% each section	2000	9.7 hy at .080 amp DC	Polarity additive. Steel case filled with asphalt compound: temperature of fusion 300°F (149°C).
T-101, T-102	A-4661		Pri. Sec.	#5/41 Litz #5/41 Litz	86 86			115 μh ±5% 115 μh ±5%	Coils universal-wound in same direction using 0.125" cam, 91/95 gears, 2:1 idler. Coils impregnated with Q-MAX. Inductance measurement taken at 1000 cps. Coil Q at 912 kc 75 or greater.
T-103	A-4662		Pri. Sec #1 Sec #2	#7/40 Litz #7/40 Litz #7/40 Litz	115 100 100			249 μh ±5% 197 μh ±5% 197 μh ±5%	Coils universal-wound in same direction using 0.093" cam, 75/39 gears, 2:1 idler. Coils impregnated with Q-MAX. Inductance measurement taken at 1000 cps. Primary Q at 912 kc 80 or greater, each secondary Q at 912 kc 75 or greater.
T-104	TR-1128	 <p>PRI.# 1 115V. 50/60 CPS PRI.# 2 115V. 50/60 CPS SEC.# 3 12.6V. CT. 3.0A. SEC.# 2 700V. CT. .056A. SEC.# 1 5.0V. 3.0A. GROUNDED TO CASE</p>	Pri #1 Pri #2 Sec #1 Sec #2 Sec #3	#25E #25E 2x#20E #34E 2x#20E	322 322 15 2060 tap at 1030 37 tap at 18½	6.2 6.2 .063 380 .244	700 700 2000 2000 700		Polarity additive. Mid-taps within 1% of neutral. Steel case filled with asphalt compound: temperature of fusion 300°F (149°C).

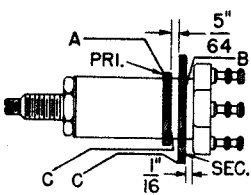
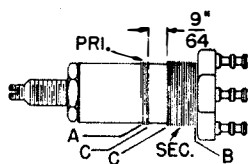
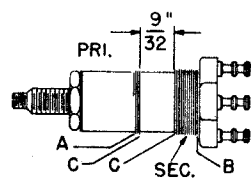
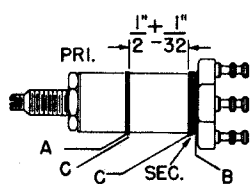

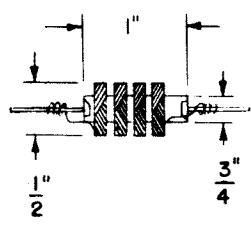
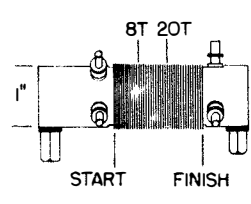
CONDITIONS FOR MEASUREMENTS

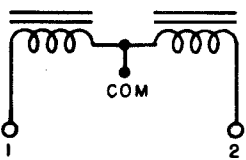
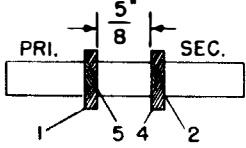
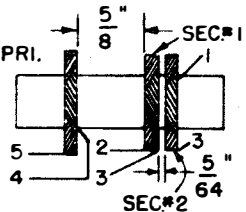
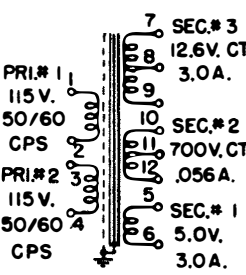
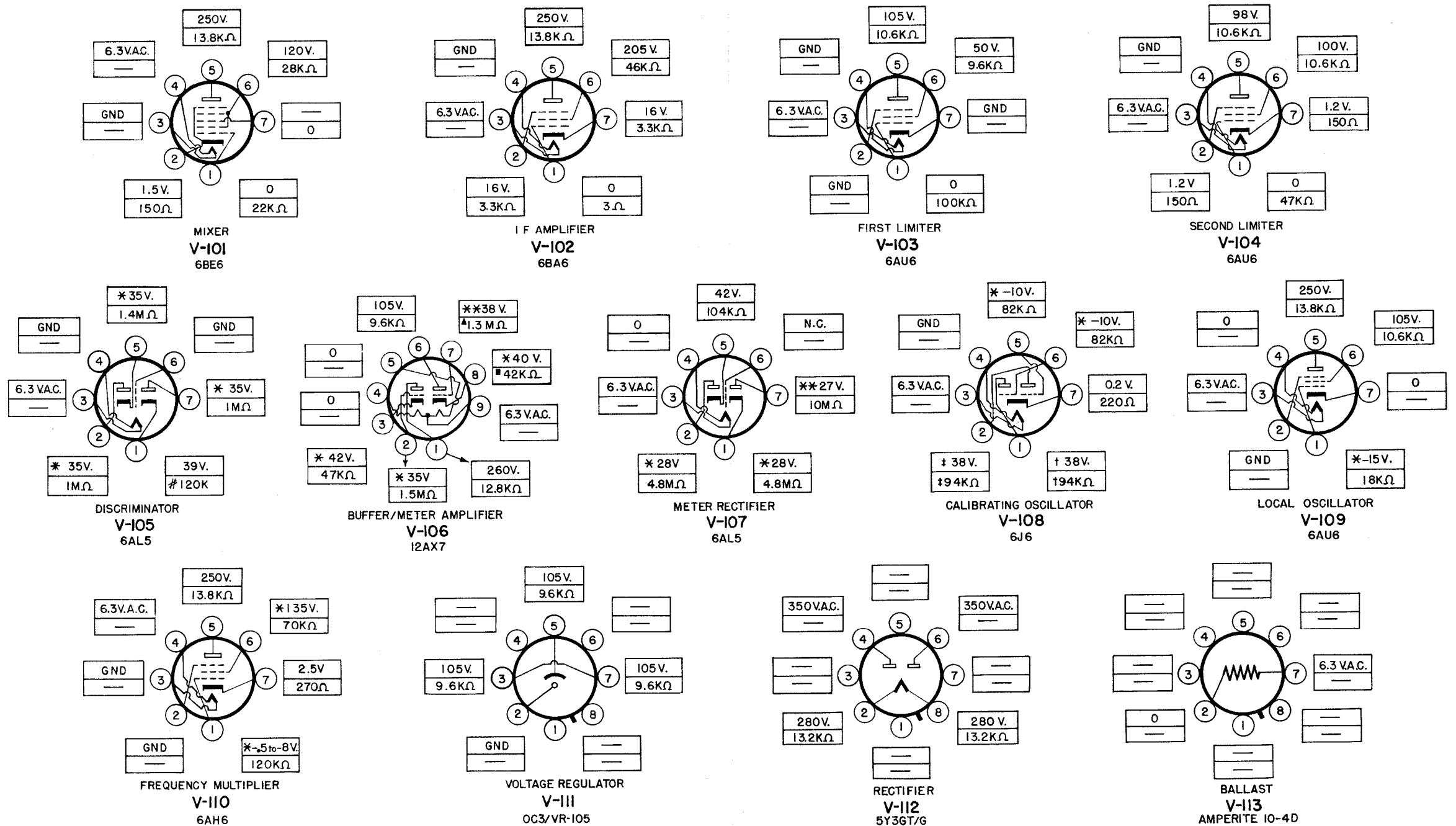
ALL MEASUREMENTS TAKEN TO GROUND WITH (E) R.F. GAIN, (F) AUDIO GAIN, (K) METER CALIB., AND R-120 SET FULLY CLOCKWISE.

VOLTAGE MEASUREMENTS ARE ACCURATE FOR 1000Ω/VOLT OR 20,000Ω/VOLT METERS EXCEPT WHERE OTHERWISE NOTED.

MEASUREMENTS ON V-105, V-106, AND V-107 SHOULD BE CHECKED FOR EACH SETTING OF THE TUNE-MEASURE (D) SWITCH.

▲ WITH (D) TUNE-MEASURE SWITCH ON TUNE OR UNKEYED SIGNAL SHOULD READ 10MΩ ON KEYED SIGNAL.

* MEASURED WITH 20,000Ω/VOLT METER WITH HIGHEST VOLTAGE RANGE SELECTED TO PROVIDE READING CLOSE TO FULL-SCALE.

** MEASURED WITH VACUUM-TUBE-VOLTMETER WITH AT LEAST 10 MEGOHMS INPUT RESISTANCE.

† WITH (C) MONITOR-CALIBRATE SWITCH ON CALIB. FREQ. A POSITION.

‡ WITH (C) MONITOR-CALIBRATE SWITCH ON CALIB. FREQ. B POSITION.

≠ WITH (D) TUNE-MEASURE SWITCH ON TUNE OR UNKEYED SIGNAL. SHOULD INDICATE 50K ON KEYED SIGNAL.

■ WITH (D) TUNE-MEASURE SWITCH ON UNKEYED SIGNAL OR KEYED SIGNAL. SHOULD READ 110KΩ ON TUNE.

Figure 7-5. Vacuum Tube Pin Connections Diagram; Resistance and Operating Voltage Chart

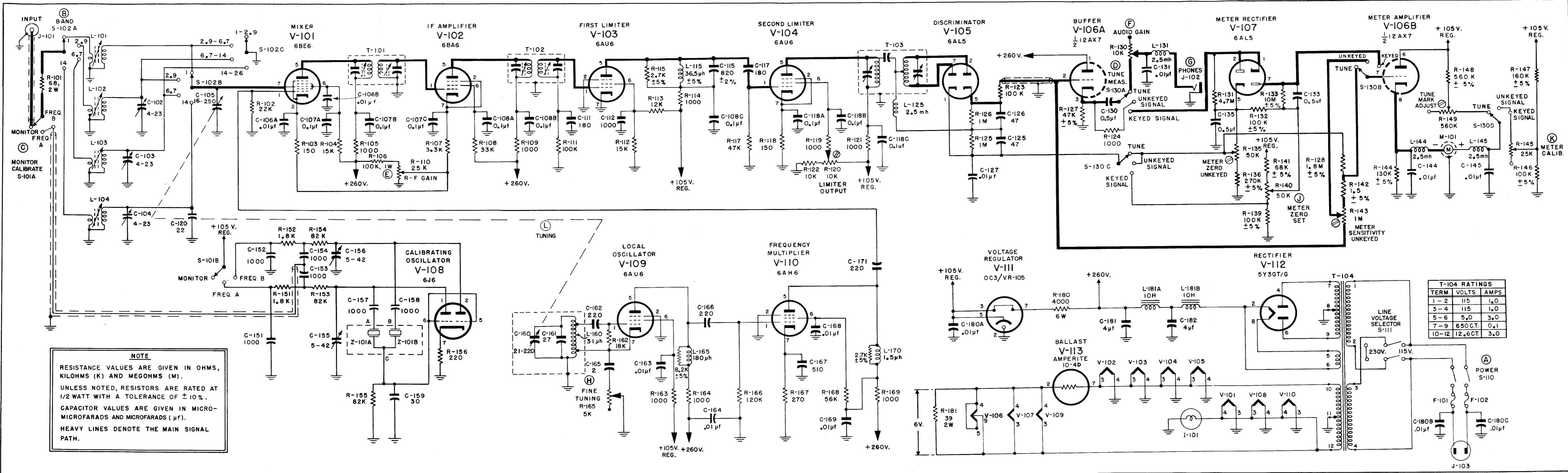

Figure 7-6. RF Monitor, Schematic Diagram

WIRE NO.	FROM	TO	WIRE NO.	FROM	TO	WIRE NO.	FROM	TO
	Cable Assembly			Cable Assembly--Contd.			Loose Wires--Contd.	
101	R-165-2	C-165 (TB-101)	171	R-128 (TB-102)	R-135-2	341	XZ-101-COMM.	X-108-5
102	X-111-3	X-111-5	172	R-132 (TB-102)	X-107-5	342	X-108-5	X-108-6
103	C-180-C	XF-102-A	173	R-131 (TB-102)	R-135-3	343	XZ-101-A	C-157 (TB-105)
104	C-180-B	XF-101-A	174	R-135-1	R-136 (TB-102)	344	R-153 (TB-105)	X-108-1
105	S-110-4	S-111-2	175			345	R-153 (TB-105)	C-155 TERM B
106	S-110-3	S-111-1	176	C-133-C	R-140-2	346	C-158 (TB-105)	XZ-101-B
107	S-111-2	R-140-1	177	R-141 (TB-102)	R-140-3	347	R-154 (TB-105)	X-108-2
108	S-111-1	T-104-4	178	S-101-3	R-141 (TB-102)	348	R-154 (TB-105)	C-156 TERM B
109	S-111-4	T-104-3	179	R-148 (TB-102)	X-106-6	349	X-106-2	R-143-1
110	S-111-3	T-104-2	180	R-148 (TB-102)	R-149-2	350	X-106-3	C-130-A
111	T-104-7	X-112-4	181	R-146 (TB-102)	R-145-2	351	R-135-3	C-135-A
112	T-104-9	X-112-6	182	X-106-8	L-144 (TB-106)	352	C-135-C	GND. LUG AT C-135
113	T-104-8	X-112 GND.	183	C-125 (TB-104)	S-130-A-9	353	S-130-A-7	C-133-A
114	T-104-5	X-112-8	184	R-149-1	S-130-A-2	354	C-130-C	C-130-C
115	T-104-6	X-112-2	185	S-130-A-1	L-145 (TB-106)	355	R-124 (TB-102)	R-124 (TB-102)
116	X-112-2	L-181-B-1	186	S-130-A-4	R-145-1	356	S-130-B-12	X-107-1
117	L-181-(A-B) COMM.	C-182-A	187	S-130-A-10	R-128 (TB-102)	357	X-107-1	R-131 (TB-103)
118	L-181-A-2	R-180-A	188	S-130-A-12	R-139 (TB-102)	358	X-107-1	X-107-2
119	R-180-A	C-181-A	189	R-139 (TB-102)	R-140-1	359	X-106-7	X-107-7
120	R-180-B	X-111-7	190	R-144 (TB-102)	X-106-8	360	S-130-B-2	R-142 (TB-102)
121	X-111-3	C-180-A	191	X-106-1	C-181-A	361	S-130-B-3	R-143-2
122	X-113-7	X-102-3	192	R-130-B-10	R-130-1	362	S-130-B-4	C-133-A
123	T-104-10	X-113-7	193	R-165-1	GND. LUG AT M-101	363	L-102-C	C-102 GND. A
124	X-102-3	X-103-3	194	R-110-1	C-144 (TB-106)	364	L-103-C	C-102 GND. B
125	X-103-3	X-104-3	195	XI-101	R-181 (TB-105)	365	L-104-C	C-104 GND. A
126	X-104-3	X-105-3	196	S-101-3	R-163 (TB-105)	366	L-101-C	GND. LUG AT C-135
127	T-104-12	X-101-4				367	L-101-B	S-102-B-2
128	X-101-4	X-108-3				368	L-102-B	S-102-B-3
129	T-104-12	X-107-3				369	L-103-B	S-102-B-4
130	X-107-3	X-106-9				370	L-104-B	S-102-B-5
				<u>Loose Wires</u>				
131	X-106-9	R-181 (TB-105)	301	X-108 GND.	C-182-B	371	L-101-A	S-102-B-8
132	X-113-2	X-107-4	302	X-107 GND.	C-181-B	372	S-102-A-12	C-104 GND. A
133	X-107-4	X-106-5	303	X-111-2	X-111 GND.	373	L-103-A	S-102-B-10
134	X-106-5	R-181 (TB-105)	304	R-126 (TB-104)	X-105-5	374	L-102-A	S-102-B-9
135	T-104-11	X-113 GND.	305	C-125 (TB-104)	X-105-1	375	L-104-A	S-102-B-11
136	C-127 (TB-104)	X-105 GND.	306	X-105-6-CEN., 4	X-105 GND.	376	X-102-A-2	S-102-B-2
137	C-118-6	C-118-B	307	X-104-CEN., 4	X-104 GND.	377	X-102-A-3	S-102-B-3
138	R-114 (TB-104)	R-120-1	308	X-103-2, CEN.	X-103-4	378	S-102-A-4	S-102-B-4
139	R-120-1	X-111-3	309	X-103-CEN., 7	X-103 GND.	379	S-101-11	S-101-12
140	X-103-6	R-112 (TB-104)	310	X-102-CEN., 4	X-102 GND.	380	S-130-A-10	S-130-A-11
141	R-117 (TB-104)	X-103 GND.	311	R-117 (TB-104)	X-104-1	381	S-130-A-3	S-130-A-4
142	C-107-C	R-107 (TB-104)	312	L-115 (TB-104)	X-103-5	382	L-102-B	C-102 TERM. A
143	R-107 (TB-104)	R-103 (TB-105)	313	C-118-A	X-104-2	383	L-103-B	C-103 TERM. A
144	R-107 (TB-104)	R-110-2	314	X-102-6	C-108-A	384	L-104-B	C-104 TERM. A
145	R-106 (TB-105)	R-110-3	315	R-107 (TB-104)	X-102-2	385	X-101-7	L-102-D
146	GND. LUG AT C-135	XI-101	316	R-104 (TB-103)	C-107-A	386	L-102-D	S-102-B-1
147	X-101-6	R-104 (TB-103)	317	R-105 (TB-103)	C-107-B	387	XF-102-B	S-110-5
148	X-101-6	C-106-B	318	R-119 (TB-104)	C-118-B	388	XF-101-B	S-110-6
149	X-101-2	R-103 (TB-103)	319	X-106-4	X-106-5	389	C-144, C-145 (TB-106)	GND. LUG AT M-101
150	X-101-2	R-104 (TB-103)	320	X-104-2	X-104-7	390	C-171 (TB-101)	X-101-1
151	R-104 (TB-103)	R-106 (TB-105)	321	X-102-2	X-102-7	391	S-111-5	S-111-6
152	R-106 (TB-105)	C-181-A	322	C-101-2	C-181-A	392	C-155 GND.	GND. "A"
153	X-101-5	T-101-2	323	X-101-CEN., 3	X-101 GND.	393	C-156 GND.	GND. "A"
154	R-119 (TB-104)	R-120-2	324	C-107-B	T-101-4	394	C-102 GND. LUG	LUG AT C-102 GND. A
155	R-122 (TB-104)	R-120-3	325	C-108-B	T-102-4	395	C-104 GND. LUG	LUG AT C-104 GND. B
156	S-101-3	X-111-5	326	R-108 (TB-104)	C-108-A	396	C-104 GND. LUG	LUG AT C-104 GND. A
157	S-101-11	C-153 (TB-105)	327	R-109 (TB-104)	C-108-B	397	J-103-A	C-180-B
158	J-101	S-101-10	328	L-115 (TB-104)	C-108-C	398	J-103-B	C-180-C
159	R-123 (TB-104)	X-106-2	329	R-118 (TB-104)	C-118-A	399	R-132 (TB-102)	C-133-C
160	R-124 (TB-105)	S-101-5	330	R-121 (TB-104)	C-118-C	400	X-108-CEN., 4	X-108 GND.
161	R-125 (TB-105)	S-101-6	331	X-102-5	T-102-2	401	S-102-B-1	C-105 STATOR
162	C-159 (TB-105)	X-108 GND.	332	X-102-1	T-101-5			TERMINAL
163	R-163 (TB-105)	PIN B (TB-101)	333	X-103-1	T-102-5			
164	R-106 (TB-105)	R-164 (TB-101)	334	X-102 GND.	T-101-1	402	C-105 ROTOR LUG	C-104 GND. LUG
165	GROUND "A"	C-164 (TB-101)	335	X-104-5	T-103-4			
166	R-181 (TB-105)	PIN C (TB-101)	336	C-118-C	T-103-5			
167	R-181 (TB-105)	PIN A (TB-101)	337	L-125 (TB-104)	T-103-3			
168	R-142 (TB-102)	R-143-3	338	X-105-2	T-103-2			
169	R-127 (TB-102)	X-107 GND.	339	X-105-7	T-103-1			
170	R-124 (TB-102)	X-106-3	340	C-159 (TB-105)	XZ-101-COMM.			

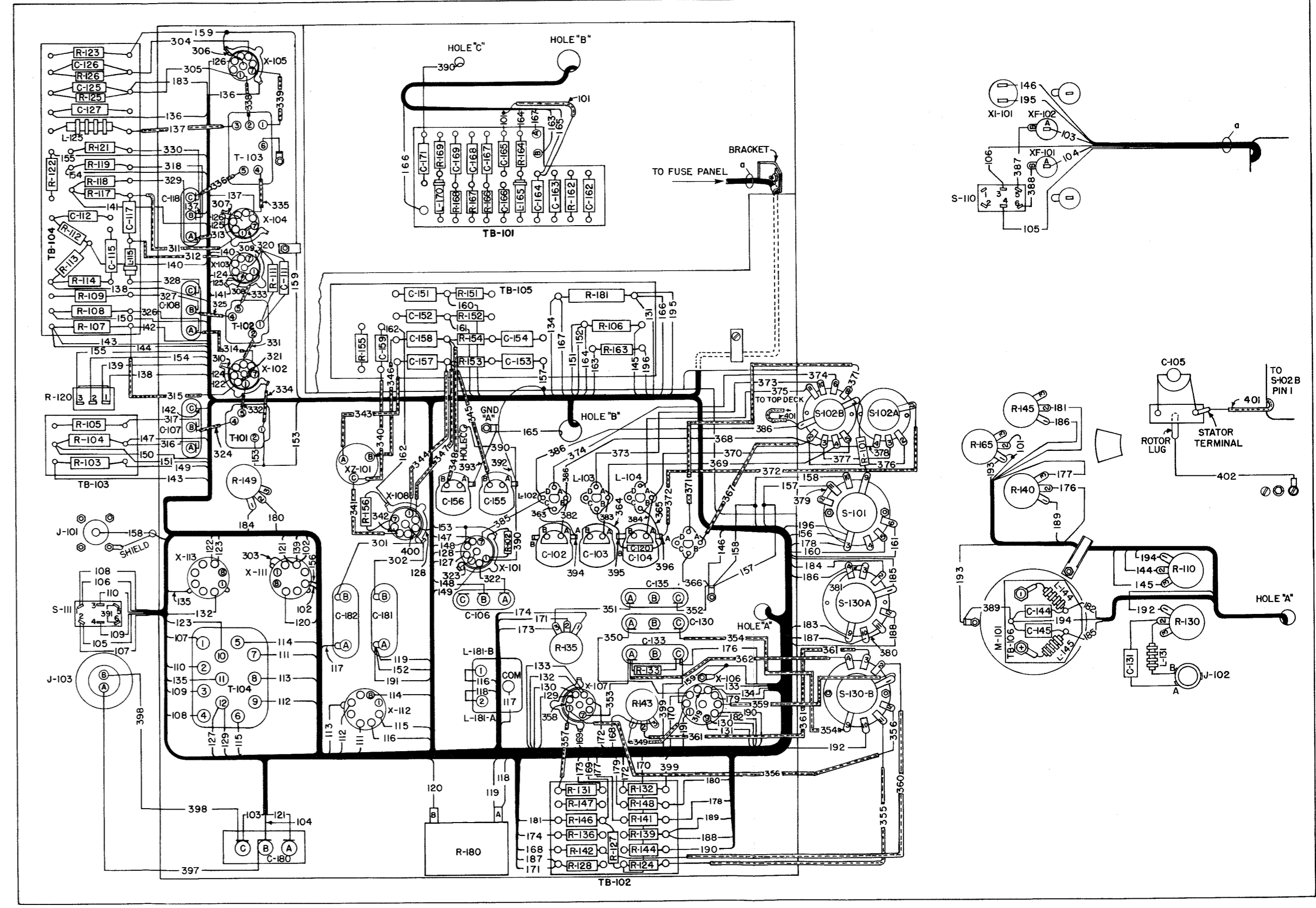

Figure 7-7. RF Monitor, Wiring Diagram

SECTION 8

PARTS LISTS

Table 8-4 constitutes the major portion of this section and is arranged first in alphabetical order, and then in numerical order of the reference symbols used. A reference symbol is assigned to each significant electrical and mechanical component of the equipment for which a replacement may be required or to which a reference is made in the drawings and text of this instruction book.

Each of the major units of the Frequency Shift Monitor OCT-2 and OCT-3 is assigned a separate numerical series: 100-199, 201-299, 301-399, etc. The first significant figure identifies the unit in which the referenced component is used. The remaining two figures, together with the prefixed letter, identify the individual component referenced.

All parts having a common symbol-letter prefix are grouped together, regardless of the major unit in which it may be located.

Note

All tubes used in this equipment are JAN approved types.

**TABLE 8-1. WEIGHTS AND DIMENSIONS
OF UNCRATED SPARE PARTS BOXES**

EQUIPMENT SPARES				
Overall Dimensions			Volume	Weight
Height	Width	Depth		
$12\frac{1}{4}$	$31\frac{9}{16}$	$16\frac{11}{16}$	3.75	75
TENDER SPARES				
$15\frac{1}{4}$	$31\frac{9}{16}$	$19\frac{11}{16}$	5.48	95
STOCK SPARES				
$12\frac{1}{4}$	$41\frac{1}{2}$	$22\frac{1}{4}$	6.53	140

**TABLE 8-2. SHIPPING WEIGHTS AND DIMENSIONS
OF CRATED SPARE PARTS BOXES**

EQUIPMENT SPARES					
Shipping Box Number	Overall Dimensions			Volume	Weight
	Height	Width	Depth		
1 of 1	$14\frac{1}{4}$	$35\frac{9}{16}$	$18\frac{11}{16}$	5.50	115
TENDER SPARES					
1 of 1	$17\frac{1}{4}$	$35\frac{9}{16}$	$21\frac{11}{16}$	7.69	140
STOCK SPARES					
1 of 1	$12\frac{1}{4}$	$41\frac{1}{2}$	$22\frac{1}{4}$	6.53	140

Unless otherwise stated, dimensions are inches, volume cubic feet, weight pounds.

TABLE 8-3. LIST OF MAJOR UNITS

Symbol Group	Quantity	Name of Major Unit	Navy Type Designation
101-199	1	RF Monitor	-60170
201-299	0	Accessories, Cables, and Tools
301-399	1	Cabinet	-10708
401-499	1	Dust Cover	-10709

TABLE 8-4. COMBINED PARTS AND SPARE PARTS LIST

PARTS							SPARE PARTS
SYMBOL DESIG.	NAME OF PART AND DESCRIPTION	FUNCTION	JAN OR NAVY TYPE DESIG.	MFR. AND MFR'S. DESIG.	HAZELTINE PART/DWG NUMBER	ALL SYMBOL DESIGNATIONS INVOLVED	EQUIP. QUAN.
101-199 series	MONITOR UNIT, RF: freq range 1-26 mc; shock mtd in steel cabinet for shipboard use, rack mtd w/dust cover for shore use; 19" wd x 10 $\frac{1}{2}$ " h x 17" d; 115 or 230 v AC, 50/60 cps; ea equip incl 2 instruction books, 1 set equip spare parts; wt 65 lb; p/o Frequency Shift Monitor AN type OCT-2 (shipboard equip), Frequency Shift Monitor AN type OCT-3 (shore equip); Navy spec RE 13A 958A. (A) STRUCTURAL PARTS	OCT-2, OCT-3 RF Monitor Unit Chassis	-60170	Hazeltine Elec part/dwg A-4652	A-4652		0
A-101	HOUSING: (heat insulated); insulator and shielding type; aluminum alloy casting outside and inside, styrofoam 103.7 insulator between casting walls; casting baked for stress relief; 11 $\frac{1}{2}$ " lg x 8 $\frac{11}{16}$ " wd x 9 $\frac{11}{32}$ " h overall; five 0.234" diam mtg holes on top flange edge, ten #10-32 thd tap mtg holes for aluminum cover.	C-160 heat insulation and shield		Hazeltine Elec part/dwg A-4451	A-4451	A-101	0
A-102 through A-301	Not used.						
A-302	CABINET: provides complete housing for the RF Monitor Unit; CRS, copper flash, flat gray enamel finish; without contents; 21 $\frac{3}{4}$ " wd x 13 $\frac{3}{8}$ " h x 14 $\frac{5}{16}$ " d, $\frac{1}{16}$ " thk stock; single compartment; incl 4 cad pl steel vibration shock mounts w/rubber inserts 21 louvers at rear and 20 louvers ea side, four #12-24 thd tapped holes equally spaced ea side of front view, steel slide rails w/phenolic surface for chassis; p/o Frequency Shift Monitor AN type OCT-2 (shipboard Equip); Navy spec RE 13A 958A.	Housing for RF Monitor Unit Chassis, OCT-2 (shipboard equip)	-10708	Hazeltine Elec part/dwg A-4653	A-4653	A-302	0

ORIGINAL

A-401	COVER: provides shielding for the RF Monitor Unit; used w/ and p/o Frequency Shift Monitor AN type OCT-3 (shore equip); one-piece, "L"-shape, thirty-eight $\frac{3}{4}$ " diam ventilating holes through top, six louvers $4\frac{7}{8}$ " lg on end, incl four wing nut fasteners Dzus Cat #AW-4-30; CRS, cad pl; $14\frac{5}{8}$ " lg x $17\frac{5}{16}$ " wd x $6\frac{15}{16}$ " h; secured to chassis by four wing nut fasteners on $16\frac{1}{2}$ " x $4\frac{1}{2}$ " mtg/c; Navy spec RE 13A 958A.	Dust cover for RF Monitor Unit Chassis, OCT-3 (shore equip)	-10709	Hazeltine Elec part/dwg A-4515	A-4515	A-401	0
	(C) CAPACITORS						
C-101	Not used.						
C-102	CAPACITOR, variable: air dielectric; plate meshing type; max capacitance $23\ \mu\text{mf}$, min capacitance $4\ \mu\text{mf}$ SLC characteristic; $1\frac{1}{2}$ " lg x $1\frac{1}{32}$ " h x $1\frac{15}{16}$ " wd, shaft $\frac{5}{16}$ " lg incl locking nut; screwdriver adj; 3 rotor and 4 stator plates, brass, cad pl; 180 deg rotation; ceramic ins; 1 solder lug and 1 post term; two #4-40 thd tap mtg inserts face side $2\frac{1}{32}$ " c to c; unit to conform with spec JAN-C-92.	Input air trimmer	-481973	Hammerlund code APC-25	CV-1017-1	C-102, C-103, C-104	2
C-103	Same as C-102.	Input air trimmer					
C-104	Same as C-102.	Input air trimmer					
C-105	CAPACITOR, variable: air dielectric; plate meshing type; max capacitance $250\ \mu\text{mf} \pm 3\%$, min capacitance $16\ \mu\text{mf}$; SLC characteristic; airgap $0.047\frac{1}{2}$ "; approx $2\frac{25}{32}$ " lg x $2\frac{3}{32}$ " h x $2\frac{1}{16}$ " wd, round metal shaft $\frac{1}{2}$ " lg beyond bushing, $\frac{3}{8}$ "-32 thd bushing $1\frac{13}{32}$ " lg; knob control; 16 rotor end 17 stator plates, polished aluminum; 180 deg rotation; mycalex insulation; solder lug term; single hole mtg bushing $\frac{3}{8}$ "-32 thd x $1\frac{13}{32}$ " lg.	Input tuning	-484851	Natl Co per Haz CV-1014	CV-1014	C-105	1
C-106	CAPACITOR, fixed: paper; 3 sect; $10,000\ \mu\text{mf} +40\% -15\%$ 1000 vdcw; spec JAN-C-25.	Consists of C-106A, C-106B, C-106C	CP67B5EG103X		CP67B5EG103X	C-106, C-106A, C-106B, C-106C, C-180, C-180A, C-180B, C-180C	1
C-106A	Part of C-106.	V-101 cathode bypass					
C-106B	Part of C-106.	V-101 screen grid bypass					
C-106C	Not used.						
C-107	CAPACITOR, fixed: paper; 3 sect; $100,000\ \mu\text{mf} +40\% -15\%$; 600 vdcw; spec JAN-C-25.	Consists of C-107A, C-107B, C-107C	CP69B5EF104X		CP69B5EF104X	C-107, C-107A, C-107B, C-107C, C-108, C-108A, C-108B, C-108C, C-118, C-118A, C-118B, C-118C	2

TABLE 8-4. COMBINED PARTS AND SPARE PARTS LIST—Cont'd

SYMBOL DESIG.	NAME OF PART AND DESCRIPTION	FUNCTION	PARTS				SPARE PARTS	
			JAN OR NAVY TYPE DESIG.	MFR. AND MFR.'S. DESIG.	HAZELTINE PART/DWG NUMBER	ALL SYMBOL DESIGNATIONS INVOLVED	EQUIP. QUAN.	
C-107A	Part of C-107.	V-101 screen grid decoupling						
C-107B	Part of C-107.	V-101 plate decoupling						
C-107C	Part of C-107.	V-102 cathode bypass						
C-108	Same as C-107.	Consists of C-108A, C-108B, C-108C						
C-108A	Part of C-108.	V-102 screen grid bypass						
C-108B	Part of C-108.	V-102 plate decoupling						
C-108C	Part of C-108	V-103 plate decoupling						
C-109	Not used.							
C-110	Not used.							
C-111	CAPACITOR, fixed: mica; 180 μmf $\pm 5\%$; 500 vdcw; spec JAN-C-5.	V-103 grid leak bypass	CM20C181J		CM20C181J	C-111, C-117	1	
C-112	CAPACITOR, fixed: mica; 1000 μmf $\pm 5\%$; 500 vdcw; spec JAN-C-5.	V-103 screen grid bypass	CM25C102J		CM25C102J	C-112	1	
C-113	Not used.							
C-114	Not used.							
C-115	CAPACITOR, fixed: mica; 820 μmf $\pm 2\%$; 500 vdcw; spec JAN-C-5.	V-103 plate tuning	CM25E821G		CM25E821G	C-115	1	
C-116	Not used.							
C-117	Same as C-111.	V-104 grid coupling						
C-118	Same as C-107.	Consists of C-118A, C-118B, C-118C						
C-118A	Part of C-118.	V-104 cathode bypass						
C-118B	Part of C-118.	V-104 screen grid bypass						
C-118C	Part of C-118.	V-104 plate decoupling						
C-119	Not used.							

ORIGINAL

ORIGINAL

C-120	CAPACITOR, fixed: 22 $\mu\mu\text{f}$ $\pm 10\%$; 500 vdcw; spec JAN-C-20.	Input trimming padder	CC21SL220K	CC21SL220K	C-120	1
C-121 through C-124	Not used.					
C-125	CAPACITOR, fixed: mica; 47 $\mu\mu\text{f}$ $\pm 5\%$; 500 vdcw; spec JAN-C-5.	V-105 output r-f bypass	CM20C470J	CM20C470J	C-125, C-126	1
C-126	Same as C-125.	V-104 output r-f bypass				
C-127	CAPACITOR, fixed: mica; 10,000 $\mu\mu\text{f}$ $\pm 5\%$; 300 vdcw; spec JAN-C-5.	V-105 cathode bypass	CM40C103J	CM40C103J	C-127	1
C-128	Not used.					
C-129	Not used.					
C-130	CAPACITOR, fixed: paper; 500,000 $\mu\mu\text{f}$ $+40\%$ -15% ; 600 vdcw; spec JAN-C-25.	V-106A output coupling	CP69B1EF504X	CP69B1EF504X	C-130, C-133, C-135	2
C-131	CAPACITOR, fixed: mica; 10,000 $\mu\mu\text{f}$ $\pm 10\%$; 300 vdcw; spec JAN-C-5.	J-102 r-f bypass	CM40C103K	CM40C103K	C-131, C-144, C-145, C-163, C-164, C-168, C-169	2
C-132	Not used.					
C-133	Same as C-130.	V-107 output filter				
C-134	Not used.					
C-135	Same as C-130.	V-107 cathode bypass				
C-136 through C-143	Not used.					
C-144	Same as C-131.	M-101 r-f bypass				
C-145	Same as C-131.	M-101 r-f bypass				
C-146 through C-150	Not used.					
C-151	CAPACITOR, fixed: mica; 1000 $\mu\mu\text{f}$ $\pm 10\%$; 500 vdcw; spec JAN-C-5.	V-108 decoupling	CM35C102K	CM35C102K	C-151, C-152, C-153, C-154, C-157, C-158	2
C-152	Same as C-151.	V-108 decoupling				
C-153	Same as C-151.	V-108 output coupling				
C-154	Same as C-151.	V-108 output coupling				

PARTS LISTS

NAVSHPIS 91131
OCT-2 and OCT-3Section 8
C-120—C-154

8-5

TABLE 8-4. COMBINED PARTS AND SPARE PARTS LIST—Cont'd

PARTS							SPARE PARTS
SYMBOL DESIG.	NAME OF PART AND DESCRIPTION	FUNCTION	JAN OR NAVY TYPE DESIG.	MFR. AND MFR'S. DESIG.	HAZELTINE PART/DWG NUMBER	ALL SYMBOL DESIGNATIONS INVOLVED	EQUIP. QUAN.
C-155	CAPACITOR, variable: air dielectric; plate meshing type; max capacitance 42 μmf , min capacitance 5 μmf ; SLC characteristic; $1\frac{5}{32}$ " lg x $1\frac{1}{32}$ " h x $\frac{15}{16}$ " wd, shaft $\frac{5}{16}$ " lg, incl locking nut; screwdriver adj; 7 rotor and 7 stator plates, brass, cad pl; 180 deg rotation; ceramic ins; 1 solder lug and 1 post term; two #4-40 thd tap mtg inserts face side $2\frac{1}{32}$ " c to c; unit to conform with spec JAN-C-92.	Z-101A fine frequency adjustment	-482062	Hammerlund code APC-50	CV-1017-2	C-155, C-156	1
C-156	Same as C-155.	Z-101B fine frequency adjustment					
C-157	Same as C-151.	V-108 feedback coupling					
C-158	Same as C-151.	V-108 feedback coupling					
C-159	CAPACITOR, fixed: mica; 30 μmf $\pm 10\%$; 500 vdcw; spec JAN-C-5.	V-108 grid capacitor	CM20C300K		CM20C300K	C-159	1
C-160	CAPACITOR, variable: air dielectric; plate meshing type; max capacitance 220 μmf $\pm 2 \mu\text{mf}$, min capacitance 21 μmf $\pm 1 \mu\text{mf}$; SLF characteristic; air-gap 0.03025"; $4\frac{27}{32}$ " lg x $3\frac{5}{64}$ " h x $3\frac{31}{32}$ " wd overall; gear drive, precision split worm gear, equipped w/precision ball bearing, ratio 100:1 over 360 deg; 15 rotor and 14 stator plates, copper, nickel and silver pl; 180 deg rotation; ceramic ins; solder lug term; three #8-32 thd tap mtg holes on bottom; modified from Cardwell type #4.080.	V-109 local oscillator tuning	-483390-A	Hazeltine Elec part/dwg CO-1211	CO-1211	C-160	1
C-161	CAPACITOR, fixed: ceramic dielectric; 27 μmf $\pm 5\%$; 500 vdcw; spec JAN-C-20.	V-109 local oscillator padder	CC26HG270J		CC26HG270J	C-161	1
C-162	CAPACITOR, fixed: mica dielectric; 220 μmf $\pm 10\%$; 500 vdcw; spec JAN-C-5.	V-109 grid coupling	CM20C221K		CM20C221K	C-162, C-166, C-171	1
C-163	Same as C-131.	V-109 screen grid bypass					
C-164	Same as C-131.	V-109 plate decoupling					

ORIGINAL

C-165	CAPACITOR, fixed: ceramic; 2 $\mu\mu\text{f}$ $\pm 0.5 \mu\mu\text{f}$; 500 vdcw; spec JAN-C-20.	V-109 local oscillator fine tuning	CC21CK020D	CC21CK020D	C-165	1
C-166	Same as C-162.	V-110 grid coupling				
C-167	CAPACITOR, fixed: mica; 510 $\mu\mu\text{f}$ $\pm 5\%$; 500 vdcw; spec JAN-C-5.	V-110 cathode bypass	CM20C511J	CM20C511J	C-167	1
C-168	Same as C-131.	V-110 screen grid bypass				
C-169	Same as C-131.	V-110 plate decoupling				
C-170	Not used.					
C-171	Same as C-162.	V-101 injection grid coupling				
C-172 through C-179	Not used.					
C-180	Same as C-106.	Consists of C-180A, C-180B, C-180C				
C-180A	Part of C-180.	+105 v regulated line filter				
C-180B	Part of C-180.	J-103 a-c line bypass				
C-180C	Part of C-180.	J-103 a-c line bypass				
C-181	CAPACITOR, fixed: paper dielectric; 4 μf +40% -15%; 600 vdcw; hermetically sealed metallic case; 3 $\frac{7}{8}$ " x 2 $\frac{1}{2}$ " wd x 1 $\frac{3}{16}$ " thk, less term; oil filled; two #10-32 stud term on ceramic bushings, 1 $\frac{5}{16}$ " h, 1 $\frac{1}{8}$ " c to c; no int ground connections; clamp mtd; spec JAN-C-25.	+225 v line filter	CP70E1EF405X	CP70E1EF405X	C-181, C-182	1
C-182	Same as C-181.	+225 v line filter				
(E) MISCELLANEOUS ELECTRICAL PARTS						
E-101	SHIELD, tube: (miniature); brass, nickel-plated; cylindrical, $\frac{1}{2}$ " diam top opening bayonet mtg; inside dimen 1.736" h x 0.810" ID; 2 mtg bosses at 180 deg, tension music wire coil spring 1 $\frac{1}{2}$ " free length; spec JAN-S-28.	V-101 shield	SOS 6	MS-10008-2	E-101, E-102, E-103, E-104, E-108, E-109, E-110	2
E-102	Same as E-101.	V-102 shield				
E-103	Same as E-101.	V-103 shield				
E-104	Same as E-101.	V-104 shield				

TABLE 8-4. COMBINED PARTS AND SPARE PARTS LIST—Cont'd

SYMBOL DESIG.	NAME OF PART AND DESCRIPTION	FUNCTION	PARTS				SPARE PARTS
			JAN OR NAVY TYPE DESIG.	MFR. AND MFR'S. DESIG.	HAZELTINE PART/DWG NUMBER	ALL SYMBOL DESIGNATIONS INVOLVED	EQUIP. QUAN.
E-105	SHIELD, tube: (miniature); brass, nickel pl; cylindrical, $\frac{1}{2}$ " diam top opening; bayonet mtg; inside dimen 1.424" h x 0.810" ID; 2 mtg bosses at 180 deg, tension music wire coil spring $1\frac{1}{2}$ " free length; spec JAN-S-28.	V-105 shield	SOS 3		MS-10008-1	E-105, E-107	1
E-106	SHIELD, tube: brass, nickel-plated; cylindrical, $1\frac{9}{32}$ " diam top opening; bayonet mtg; inside dimen 1.925" lg x 0.950" ID; 2 mtg bosses at 180 deg; tension music wire coil spring $1\frac{1}{2}$ " free length.	V-106 shield		Cinch part 16G12627	MS-12215-2	E-106	1
E-107	Same as E-105.	V-107 shield					
E-108	Same as E-101.	V-108 shield					
E-109	Same as E-101.	V-109 shield					
E-110	Same as E-101.	V-110 shield					
E-111	CLAMP: electron tube; stainless steel; passivate finish; clip and tension loop type; $1\frac{5}{32}$ " ID when closed, $\frac{3}{4}$ " h, elongated hole in bkt for #10 screw; for small tube base.	V-111 clamp	-491678	Birtcher type 926A	CP-10039	E-111	1
E-112	CLAMP: electron tube; stainless steel; passivate finish; strap and clip type w/tension loop; $\frac{3}{4}$ " h mtg bkt attached to $1\frac{1}{4}$ " ID strap; #10 hole in mtg bkt; for intermediate tube base $1\frac{1}{4}$ " diam.	V-112 clamp	-49679	Birtcher type 926B	CP-10040	E-112, E-113	1
E-113	Same as E-113.	V-113 clamp					
(F) FUSES							
F-101	FUSE, cartridge: 2 amp; 250 v, rated continuous at 110% load, opens in one hour at 135% load, in 2 min at 200%; one time; glass body; ferrule term; $1\frac{1}{4}$ " lg x $\frac{1}{4}$ " diam overall; term $\frac{1}{4}$ " diam x $\frac{1}{4}$ " d.	Main a-c line fuse	-28032-2	Buss type 3AG 2 Littelfuse part 1042	FU3-2	F-101, F-102, F-103, F-104	20
F-102	Same as F-101.	Main a-c line fuse					
F-103	Same as F-101.	F-101 spare fuse					

F-104	Same as F-101.	F-102 spare fuse					
	(H) HARDWARE						
H-101 through H-112	Not used.						
H-113	NUT, packing: gland type; stainless steel, passivate finish; $\frac{1}{4}$ "-28 int thd, $\frac{1}{2}$ "-20 ext thd shoulder; $\frac{1}{16}$ " thk; $\frac{5}{8}$ " wd across flats; hex head $\frac{1}{8}$ " thk.	O-101 gland nut	Hart/Amer-type per Haz NT-593	NT-593	H-113	0	
H-114	NUT, packing: gland type; stainless steel, passivate finish; $\frac{3}{8}$ "-32 thd; $\frac{1}{16}$ " thk; $\frac{5}{8}$ " wd across flats; 0.218" lg x 0.4995" diam shoulder.	C-105 shaft gland nut	Hart/Amer-type per Haz NT-594	NT-594	H-114	0	
H-115	PIN, taper: chrome alloy steel; size #7/0; 0.625" diam large end, $\frac{1}{2}$ " lg; taper $\frac{1}{4}$ " in diam per ft in lg; material per Navy spec 46 S18GR6A.	O-102 miter gear	Hart/Amer-type per Haz PN-716	PN-716	H-115	0	
H-116	PIN, alignment: stainless steel, passivate finish; $1\frac{1}{32}$ " lg x 0.0625" diam.	C-105 alignment pin	Hart/Amer-type per Haz PN-1123	PN-1123	H-116	0	
H-117	SCREW, set: Allen drive; csk head; steel, copper pl and cad pl; 0.250" diam, $\frac{1}{4}$ "-28 thd; $\frac{5}{8}$ " lg; cup point.	O-101, O-107 adjustment	Allen Mfg per Haz SC-899	SC-899	H-117	0	
H-118	Not used.						
H-119	SCREW, set: Allen drive; csk head; steel, copper pl and cad pl; 0.164" diam, #8-32 thd; $\frac{3}{16}$ " lg; cup point.	O-104 set screw	Allen Mfg per Haz SSS82C-6	SSS82C-6	H-119	0	
H-120	SCREW, set: Allen drive; csk head; steel, copper pl and cad pl; 0.164" diam, #8-32 thd; $\frac{1}{4}$ " lg; cup point.	Replacement control knob set screw	Allen Mfg per Haz SSS82C-8	SSS82C-8	H-120	0	
H-121	WASHER, flat: stainless steel, passivate finish; round 0.386" ID, $\frac{3}{4}$ " OD x 0.0375" thk.	C-105 shaft bearing washer	Hart/Amer-type per Haz WA-1144	WA-1144	H-121	0	
H-122 through H-125	Not used.						
H-126	KNOB, round: black molded phenolic; for 0.250" diam shaft; two #8-32 set screws at 120 deg; engraved white filled line on pointer; $1\frac{1}{16}$ " diam less pointer x $\frac{5}{8}$ " thk; brass insert; shaft hole $\frac{1}{2}$ " d; counter bore $\frac{5}{8}$ " diam x $\frac{3}{64}$ " d.	R-110 knob	RCA part K-868236-3	MP-10075	H-126, H-127, H-128, H-129, H-130	0	
H-127	Same as H-126.	R-130 knob					

TABLE 8-4. COMBINED PARTS AND SPARE PARTS LIST—Cont'd

PARTS							SPARE PARTS
SYMBOL DESIG.	NAME OF PART AND DESCRIPTION	FUNCTION	JAN OR NAVY TYPE DESIG.	MFR. AND MFR'S. DESIG.	HAZELTINE PART/DWG NUMBER	ALL SYMBOL DESIGNATIONS INVOLVED	EQUIP. QUAN.
H-128	Same as H-126.	R-140 knob					
H-129	Same as H-126.	R-145 knob					
H-130	Same as H-126.	R-165 knob					
H-131	KNOB: round; black molded phenolic; for 0.250" diam shaft; two #8-32 set screws at 90 deg; engraved white filled line on pointer; 1½" diam less pointer x ⅞" thk; brass insert; shafthole 15/32" d; skirted, insert coarse diamond knurl.	S-101 knob		Hazeltine Elec part/dwg MP-10074	MP-10074	H-131, H-132, H-133	0
H-132	Same as H-131.	S-102 knob					
H-133	Same as H-131.	S-130 knob					
H-134	Not used.						
H-135	Not used.						
H-136	CLAMP: inverted square U-shaped capacitor mtg clamp; stainless steel strip 0.025" thk; two spade bolt mtg studs employed; 2.562" lg x 1" wd x 3⅝" h less mtg spade bolts #6-32 thd ⅜" lg, spade bolts extend 1/16" beyond bottom of clamp; two 0.125" indentations with ⅜" spherical radius centered at edges of top crosspiece.	C-181 clamp		Hazeltine Elec part/dwg CP-10146-5	CP-10146-5	H-136, H-137	0
H-137	Same as H-136.	C-182 clamp					
H-138	CLAMP: dial; stainless steel; passivate finish; incl knob, 2 plates and guide pin ⅜" diam x 2½" lg overall; designed to hold dial 0.040" thk.	O-110 stop clamp		Hazeltine Elec part/dwg A-4744	A-4744	H-138	0
H-139	NUT, strap: strip for miniature socket and semi-circular shield mtg, cad plated, brass; 7/64" x 3/8" x 1¼" overall, 1/32" inside radius; one 0.104" diam mtg hole, two #4-40 through tap 0.875" c to c.	X-101 nut strap		Cinch part #1031	MS-10009	H-139, H-140, H-141, H-142, H-143, H-144, H-145, H-146, H-147	0
H-140	Same as H-139.	X-102 nut strap					
H-141	Same as H-139.	X-103 nut strap					
H-142	Same as H-139.	X-104 nut strap					

ORIGINAL

H-143	Same as H-139.	X-105 nut strap					
H-144	Same as H-139.	X-106 nut strap					
H-145	Same as H-139.	X-107 nut strap					
H-146	Same as H-139.	X-108 nut strap					
H-147	Same as H-139.	X-109 nut strap					
H-201	WRENCH: tuning; two 0.037" diam steel wire keys one end, pointed other end; 5½" lg x ⅜" diam; phenolic rod; straight; round "T" handle; tunes slug type IF transformers.	T-101 tuning wrench	Suffolk Per Haz WR-1015	WR-1015	H-201	1	
H-202	WRENCH: hexagonal key, double end; 0.050" max across flats; 1½¼" lg x ⅜¼" wd x 0.050" wd overall; hardened steel; arms at 90 deg; fits #4 Allen socket-head set screw.	Allen wrench	Allen Mfg part 050	WR-10000-1	H-202	1	
H-203	WRENCH: hexagonal key, double end; ⅙" max across flats; 1⅜¼" lg x ⅜" wd x ⅙" thk overall; hardened steel; arms at 90 deg; fits #5 and #6 Allen socket-head set screw.	Allen wrench	Allen Mfg part 116	WR-10000-2	H-203	1	
H-204	WRENCH: hexagonal key, double end; ⅝¼" max across flats; 1½¼" lg x 1¼" wd x ⅝¼" thk overall; hardened steel; arms at 90 deg; fits #8 Allen socket-head set screw.	Allen wrench	Allen Mfg part 564	WR-10000-3	H-204	1	
H-205	Not used.						
H-206	CLIP: single; tool holder; phosphor bronze, nickel pl; 1" lg x ⅜" wd x ⅜" h overall; uninsulated; 1 mtg hole for #8 screw.	H-202 holder	Fahnestock part #2	FP-1217	H-206	0	
H-207	CLIP: tool holder; phosphor bronze; nickel pl; 1 mtg hole for #8 screw; 1¾" lg x ⅜" wd x ⅜" h overall; for #5, #6 and #8 Allen wrenches.	H-203, H-204 holder	Fahnestock part 9C	FP-10057	H-207	0	
H-301	Not used.						
H-302	ABSORBER, shock: steel mount w/rubber inserts, incl ⅝"-18 thd bolt, hexagon nut, and lock washers; normal load rating 85-240 lb; 3" sq x 1½" h overall; four 0.255" diam mtg hcles on 2½" x 2½" mtg/c, one ⅝"-18 thd tap through center.	A-302 shock mount, used on OCT-2 only	LN Barry part C-2090T	SH-1009-10	H-302, H-303, H-304, H-305, used on OCT-2 only	1*	
H-303	Same as H-302.	A-302 shock mount					
H-304	Same as H-302.	A-302 shock mount					

* No spares with OCT-3 equipment.

TABLE 8-4. COMBINED PARTS AND SPARE PARTS LIST—Cont'd

PARTS							SPARE PARTS
SYMBOL DESIG.	NAME OF PART AND DESCRIPTION	FUNCTION	JAN OR NAVY TYPE DESIG.	MFR. AND MFR'S. DESIG.	HAZELTINE PART/DWG NUMBER	ALL SYMBOL DESIGNATIONS INVOLVED	EQUIP. QUAN.
H-305	Same as H-302.	A-302 shock mount					
H-306	BAR, chassis runner: support type; phenolic; 12½" lg x 5/8" wd x 1/8" thk; five 0.157" diam mtg holes 2.750" c to c.	Chassis runner		Hazeltine Elec part/dwg IM-1051	IM-1051	H-306, H-307	0
H-307	Same as H-306.						
(I) INDICATING LAMP							
I-101	LAMP, incandescent: 6-8 v, 0.15 amp; bulb T3-1/4 clear; 1 1/16" lg o/a; miniature bayonet; tungsten fil; burn any position; brown bead; Navy spec RE-38F-149.	Pilot lamp	TB-14		BU-10000	I-101	2
(J) JACKS AND RECEPTACLES							
J-101	CONNECTOR, receptacle: UHF coaxial receptacle Army type SO-239; single round female slotted cont; straight; 1" sq x 1 3/16" lg, less solder lug term; rated up to 1000 v, recommended 500 v; cylindrical brass body w/sq mtg plate, silver pl; tan molded bakelite insert; solder lug term one end; four 0.125" diam mtg holes in plate on 0.718" x 0.718" mtg/c; 5/8"-24 thd ext coupling mating end w/serrated edge; must not contain any material nutrient for fungi; Navy dwg RE 49F 167, Sig C dwg SC-D-5850.	RF input connector	-49194	Ind Prod part 9700	RC-10024	J-101	1
J-102	JACK, telephone: for 2 cond plug 0.250" diam; 1 1/64" lg x 3/4" diam less lugs; J1 cont arrangement; 3/8"-32 thd mtg bushing 3/8" lg, furnished in spares w/mtg hardware, less locating flat washer; requires 3/8" diam mtg hole.	Monitor phone jack	-49025-A	Mallory type SC1A	RC-1157-2	J-102	1
J-103	CONNECTOR, receptacle: two male rectangular blade cont; straight; body 1 1/32" diam x 1 1/32" lg, 2 1/2" lg x 1 25/32" wd across mtg saddle; rated up to 250 v; cylindrical metal body w/mtg saddle, cad pl; phenolic insert; two screw term; two 0.203" diam mtg holes on 2.062" mtg/c.	Power receptacle	-491076	Hubbell part #4897	RC-10067	J-103	1

(L) COILS							
L-101	TRANSFORMER, variable RF: antenna tuning coil; two windings, universal wound; unshielded; secd 57 turns #44 AWG EC; pri 20 turns #44 AWG EC; $2\frac{1}{16}$ " lg x $1\frac{5}{16}$ " diam overall; phenolic form; form $1\frac{5}{32}$ " lg x $\frac{3}{4}$ " diam overall; permeability tuned by screwdriver adjustment; $\frac{1}{4}$ "-28 thd mtg bushing w/locknut and washer; 4 solder lug term on bottom; unit lacquer finish.	RF input tuning 1.0 to 2.9 mc band	-472323	Hazeltine Elec part/dwg A-4663-1	A-4663-1	L-101	0
L-102	TRANSFORMER, variable RF: antenna tuning coil; two windings, single layer wound; unshielded; secd 25 turns #27 AWG bare E copper wire, pri $4\frac{1}{2}$ turns #27 AWG bare E copper wire; $2\frac{1}{16}$ " lg x $1\frac{5}{16}$ " diam overall; phenolic form; form $1\frac{5}{32}$ " lg x $\frac{3}{4}$ " diam overall; permeability tuned by screwdriver adjustment; $\frac{1}{4}$ "-28 thd mtg bushing w/locknut and washer; 4 solder lug term on bottom; unit lacquer finish.	RF input tuning 2.9 to 6.7 mc band	-472324	Hazeltine Elec part/dwg A-4663-2	A-4663-2	L-102	0
L-103	TRANSFORMER, variable RF: antenna tuning coil; two windings, single layer wound; unshielded; secd $11\frac{1}{4}$ turns #21 AWG bare E copper wire, pri $2\frac{1}{2}$ turns #21 AWG bare E copper wire; $2\frac{1}{16}$ " lg x $1\frac{5}{16}$ " diam overall; phenolic form; form $1\frac{5}{32}$ " lg x $\frac{3}{4}$ " diam overall; permeability tuned by screwdriver adjustment; $\frac{1}{4}$ "-28 thd mtg bushing w/locking nut and washer; 4 solder lug term on bottom; unit lacquer finish.	RF input tuning 6.7 to 14 mc band	-472326	Hazeltine Elec part/dwg A-4663-3	A-4663-3	L-103	0
L-104	TRANSFORMER, variable RF: antenna tuning coil, two windings, single layer wound; unshielded; secd 4 turns #21 AWG bare E copper wire, pri $1\frac{1}{2}$ turns #21 AWG bare E copper wire; $2\frac{1}{16}$ " lg x $1\frac{5}{16}$ " diam overall; phenolic form; form $1\frac{5}{32}$ " lg x $\frac{3}{4}$ " diam overall; permeability tuned by screwdriver adjustment; $\frac{1}{4}$ "-28 thd mtg bushing w/locknut and washer; 4 solder lug term on bottom; unit lacquer finish.	RF input tuning 14 to 26 mc band	-472327	Hazeltine Elec part/dwg A-4663-4	A-4663-4	L-104	0
L-105 through L-114	Not used.						

TABLE 8-4. COMBINED PARTS AND SPARE PARTS LIST—Cont'd

PARTS							SPARE PARTS
SYMBOL DESIG.	NAME OF PART AND DESCRIPTION	FUNCTION	JAN OR NAVY TYPE DESIG.	MFR. AND MFR'S. DESIG.	HAZELTINE PART/DWG NUMBER	ALL SYMBOL DESIGNATIONS INVOLVED	EQUIP. QUAN.
L-115	COIL, IF: choke type; incl AB type EB-2725 resistor 2700 ohms $\pm 5\%$, approx 99 turns $\frac{3}{4}$ SCE wire; inductance $36.5 \mu\text{h} \pm 5\%$ measured at 1.25 mc, max current rating 10 ma, DC resistance 2.5 ohms; cam 0.125, geared 51/75, idler 60/60; $\frac{9}{16}$ " diam x 0.406" lg, less wire leads; two axial wire leads $1\frac{1}{2}$ " lg; single winding, universal wound coil, Q MAX impregnated; (includes R-115).	V-103 plate tuning	--472319	Harnett Elec per Haz A-4715-1	A-4715-1	L-115	0
L-116 through L-124	Not used.						
L-125	COIL, RF: choke; single winding; four pie wound; unshielded; inductance 2.5 mh $\pm 10\%$. DC resistance 40 ohms $\pm 10\%$, current rating 50 mh, Q greater than 40 at 500 kc; body 1" lg x $\frac{1}{2}$ " diam, two axial wire leads $1\frac{1}{2}$ " lg; solid phenolic form; form 1" lg x $\frac{3}{4}$ " diam; two axial wire leads; coil Q MAX impregnated.	T-103 secondary insulating	--472318	Natl Co part R-50	CL-1146	L-125, L-131, L-144, L-145	4
L-126 through L-130	Not used.						
L-131	Same as L-125.	J-102 r-f filter					
L-132 through L-143	Not used.						
L-144	Same as L-125.	M-101 r-f filter					
L-145	Same as L-125.	M-101 r-f filter					
L-146 through L-159	Not used.						

L-160	COIL, RF: choke; single winding, single layer wound 120" #25 AWG bare E copper wire, tapped at 8 turns and 20 turns; unshielded; inductance 31 μ h \pm 1 μ h at 2.0 mc, Q 200 \pm 15 at 2.0 mc; 3 1/2" lg x 2 1/16" h x 1 7/16" wd, incl term and spacers; ceramic form, powdered iron core; coil form 3 1/2" lg x 1" diam, grooved 24 thd per inch, 1 5/8" lg grooved; two #6-32 thd tapped mtg spacers 3.125" c to c; 4 solder lug term; Q MAX impregnated.	V-109 local oscillator tuning	-472325	Harnett Elec per Haz A-4700	A-4700	L-160	0
L-161 through L-164	Not used.						
L-165	COIL, RF: choke; single winding, universal wound; unshielded; inductance 180 μ h \pm 5% measured at 560 kc, max current rating 10 ma, DC resistance 7.5 ohms; approx 5/16" diam, 0.406" lg less wire leads; resistor form AB type EB-8225, 8200 ohms \pm 5%; coil form 0.406" lg x 0.140" diam; two axial wire leads, ea 1 1/2" lg; coil Q MAX impregnated.	V-109 plate load	-472320	Harnett Elec per Haz A-4715-3	A-4715-3	L-165	0
L-166 through L-169	Not used.						
L-170	COIL, RF: choke; single winding, universal wound; unshielded; inductance 1.5 μ h \pm 10% measured at 15 mc, max current rating 10 ma, DC resistance 0.3 ohms; approx 1/4" diam, 0.406" lg less leads; resistor form AB type EB-2725, 2700 ohms \pm 5%; coil form 0.406" lg x 0.140" diam; two axial wire leads, ea 1 1/2" lg; coil Q MAX impregnated.	V-110 plate load	-472321	Harnett Elec per Haz A-4715-4	A-4715-4	L-170	0
L-171 through L-180	Not used.						
L-181	REACTOR: filter choke; unit per spec JAN-T-27, class "A", grade 1; dual sect; 9.7 hy at 0.080 amp DC ea sect; 170 ohms \pm 12% ea sect DC resistance; breakdown test voltage 2000 v DC between winding and case for 5-10 sec; hermetically sealed CRS case, asphalt base compound filled; 6 1/8" h x 2 7/8" lg x 2 5/16" wd overall; four 1/4"-20 thd mtg studs on 2 1/4" x 1 1/16" mtg/c; three slotted term w/ceramic bushings and neoprene gaskets, 1 common term; term marked 1, 2, COM; spec JAN-T-27.	Consists of L-181A, L-181B	-304685	Freed Trans per Haz FR-1019	FR-1019	L-181, L-181A, L-181B	1

TABLE 8-4. COMBINED PARTS AND SPARE PARTS LIST—Cont'd

PARTS							SPARE PARTS
SYMBOL DESIG.	NAME OF PART AND DESCRIPTION	FUNCTION	JAN OR NAVY TYPE DESIG.	MFR. AND MFR'S. DESIG.	HAZELTINE PART/DWG NUMBER	ALL SYMBOL DESIGNATIONS INVOLVED	EQUIP. QUAN.
L-181A	Part of L-181.	+225 v line filter					
L-181B	Part of L-181.	+225 v line filter					
(M) METER							
M-101	METER, ammeter; DC; 200 microampere movement, linear calibrated 0-1500 cps; round, steel flush mtg case; barrel $3\frac{7}{8}$ " diam x 2" lg, flange $4\frac{5}{8}$ " diam; 1% accuracy for 200 microampere movement; D'Arsonval movement; DC resistance 600 ohms +10%; calibrated for non-magnetic panel; black marking, white background, 0-1500 and 600-0-600 scale divisions w/pointer; self-contained; three $\frac{3}{16}$ " diam mtg holes on $2\frac{1}{16}$ " rad; two $\frac{5}{16}$ "-18 thd term studs 1" lg; metal scale plate gnd to case for RF shielding, no meter term to be gnd to case; built per spec JAN-I-6 part 3.	Tuning and frequency deviation meter	-22731	Weston part 643	ME-1012	M-101	0
(N) CALIBRATION CHARTS							
N-201	CHART: frequency calibration; dull finish white opaque sheet vinylite, laminated over printing with vinylite, $8\frac{1}{8}$ " lg x $4\frac{5}{16}$ " wd x 0.030" thk overall; black print lettering on white background; frame mtd OCT-2 shipboard equip, chart to lay on rack for OCT-3 shore equip; face side, FREQUENCY CALIBRATION BAND #1 is 1.0-2.9 mc, rear side, FREQUENCY CALIBRATION BAND #2 is 2.9-6.7 mc.	Band 1 and 2 calibration		Hazeltine Elec part/dwg CH-1104-1	CH-1104-1	N-201	0
N-202	CHART: frequency calibration; dull finish white opaque sheet vinylite laminated over printing with vinylite, $8\frac{1}{8}$ " lg x $4\frac{5}{16}$ " wd x 0.030" thk overall; black print lettering on white background; frame mtd OCT-2 shipboard equip, chart to lay on rack for OCT-3 shore equip; face side, FREQUENCY CALIBRATION BAND #3 is 6.7-14.0 mc, rear side, FREQUENCY CALIBRATION BAND #4 is 14.0-26.0 mc.	Band 3 and 4 calibration		Hazeltine Elec part/dwg CH-1104-2	CH-1104-2	N-202	0

ORIGINAL

(O) MECHANICAL PARTS						
O-101	SUB-ASSEMBLY: worm gear and shaft type; incl steel gear, shaft and taper pin; gear 1/3 pitch diam, 48 pitch, single thd, lead angle 3 deg 35', lead 0.0654", left-hand, Boston Gear part #LSH-LH; 4 ¹¹ / ₁₆ " lg x ³ / ₈ " diam overall; ³ / ₆₄ " d drill ea shaft end for lock mtg.	C-105, C-160 drive shaft	Hart/Amertype per Haz A-4484	A-4484	O-101	0
O-102	SUB-ASSEMBLY: miter gear and shaft type; incl brass gear, shaft and sleeve; miter gear Hazeltine Elec part/dwg #GR-1091 modified from Boston Gear part #G463; 5 ¹ / ₂ " lg x ¹³ / ₁₆ " diam overall, shaft and sleeve ¹ / ₄ " diam.	C-160 shaft and gear	Hart/Amertype per Haz A-4473	A-4473	O-102	0
O-103	DIAL: incl dial and shaft securely rolled over; aluminum dial, brass shaft; calibrated 0 through 100, etched lines; dial 4 ¹ / ₄ " diam x 0.040" thk, shaft ¹ / ₆₄ " lg x ¹ / ₂ " diam; 0.261" counterbore, 0.093" d shaft end for mtg.	C-105 dial	Cal Inst per Haz A-4491	A-4491	O-103	0
O-104	GEAR ASSEMBLY: worm gear followers; two gears coupled together, one gear soldered to gear hub; flat tobin or comm bronze gears, nickel flash; gear pitch diam 2.083, diam pitch 48, 100 teeth, left-hand-straight cut; 2 ³ / ₁₆ " diam x ⁵ / ₆₄ " thk incl hub; 0.250" diam shaft hole, two #8-32 thd tapped holes and one #4-40 thd tapped hole for set screws.	C-105 drive gear	Precision per Haz A-4864	A-4864	O-104	0
O-105	BEARING, sleeve; flanged type for drive shaft; powdered bronze 88-90%, copper 9-10% tin; ³ / ₆₄ " diam x ⁷ / ₁₆ " lg overall, 0.376" diam shank, 0.2515" ID; modified from Oilite part #F-304.	O-101 bearing sleeve	Hazeltine Elec part/dwg BB-1034	BB-1034	O-105, O-106	0
O-106	Same as O-105.	O-102 bearing sleeve				
O-107	BEARING, ball; thrust and radial; plain; light duty; 0.1562" sphere; one ball; packed with high temp grease; tight fit; chrome alloy steel.	O-101 thrust and radial rotating	Excelsior per Haz BB-1035	BB-1035	O-107	0
O-108	COUPLING ASSEMBLY, flexible: ins flexible shaft coupling, couples two ¹ / ₄ " shafts; consists of two hubs for ¹ / ₄ " shaft, mounted by flexible brass strip on unglazed ceramic ins disc; 1 ¹ / ₄ " max o/a diam x ¹³ / ₁₆ " thk; four #6-32 cup point Allen head set screws, two in each hub.	C-160 shaft coupling	Cardwell PL-5000 type "A"	CG-10008	O-108	0

TABLE 8-4. COMBINED PARTS AND SPARE PARTS LIST—Cont'd

PARTS							SPARE PARTS
SYMBOL DESIG.	NAME OF PART AND DESCRIPTION	FUNCTION	JAN OR NAVY TYPE DESIG.	MFR. AND MFR'S. DESIG.	HAZELTINE PART/DWG NUMBER	ALL SYMBOL DESIGNATIONS INVOLVED	EQUIP. QUAN.
O-109	GEAR: bevel type; brass, nickel flash; shaft driving; miter; 24 teeth; $\frac{3}{4}$ PD, 32 pitch; $\frac{13}{16}$ " diam x $\frac{25}{64}$ " thk overall, 0.2505" ID; straight face; $\frac{1}{2}$ " diam hub; #4-40 thd tap for set screw, one 0.043" diam hole for pin; modified from Boston Gear cat #54, pp #61, cat #G463.	O-102 gear		Hazeltine Elec part/dwg GR-1091	GR-1091	O-109	0
O-110	DIAL: dial w/crank knob; brass dial; dull black finish, stainless steel crank knob; 100 divisions reverse etched; horiz grained characters; 2.962" diam x $1\frac{1}{4}$ " thk overall; 0.250" diam bore for shaft mtg, two #6-32 thd tapped holes for set screws; similar to Cardwell dial #A4.198 and crank #A4.199.	C-160 dial and crank knob		Cardwell per Haz DD-1004	DD-1004	O-110	0
(P) PLUGS							
P-201	CONNECTOR, plug; 2 rectangular cont; straight; 1.156" lg x 1.531" OD less cont; cont rating 15 amp 125 v or 10 amp 250 v; cylindrical steel covered shell; cable opening 0.296" to 0.562"; 2 mtg screws in flange on armored cord grip, $\frac{1}{8}$ " c to c; resistant to salt spray, contains no materials which are nutrients for fungi.	W-201 power plug	-49825	Hubbell part 7057	PL-10064	P-201	0
P-202	CONNECTOR, receptacle: 2 "T" slots, fits parallel or tandem blades; straight; 1.906" lg x 1.531" diam overall; 15 amp 125 v, 10 amp 250 v; cylindrical composition body, armored cord grip cap; cord grip accommodates cables 0.296" OD to 0.562" OD; must not contain materials nutrient for fungi.	W-201 power receptacle mates w/J-103	-491077	Hubbell part 7084	PL-10063	P-202	0
(R) RESISTORS							
R-101	RESISTOR, fixed: composition; 68 ohms $\pm 10\%$; 2 w; spec JAN-R-11.	Input matching	RC41BF680K		RC41BF680K	R-101	1
R-102	RESISTOR, fixed: composition; 22,000 ohms $\pm 10\%$; $\frac{1}{2}$ w; spec JAN-R-11.	V-101 injection grid return	RC21BF223K		RC21BF223K	R-102	1
R-103	RESISTOR, fixed: composition; 150 ohms $\pm 10\%$; $\frac{1}{2}$ w; spec JAN-R-11.	V-101 cathode bias	RC21BF151K		RC21BF151K	R-103, R-118	1

ORIGINAL

ORIGINAL

R-104	RESISTOR, fixed: composition; 15,000 ohms $\pm 10\%$; 2 w; spec JAN-R-11.	V-101 screen grid dropping	RC40BF153K		RC40BF153K	R-104	1
R-105	RESISTOR, fixed: composition; 1000 ohms $\pm 10\%$; $\frac{1}{2}$ w; spec JAN-R-11.	V-101 plate decoupling	RC21BF102K		RC21BF102K	R-105, R-109, R-114, R-119, R-121, R-163, R-164, R-169	4
R-106	RESISTOR, fixed: composition; 100,000 ohms $\pm 10\%$; 1 w; spec JAN-R-11.	RF GAIN bias divider	RC31BF104K		RC31BF104K	R-106	1
R-107	RESISTOR, fixed: composition; 3300 ohms $\pm 10\%$; $\frac{1}{2}$ w; spec JAN-R-11.	V-102 cathode bias	RC21BF332K		RC21BF332K	R-107	1
R-108	RESISTOR, fixed: composition; 33,000 ohms $\pm 10\%$; 1 w; spec JAN-R-11.	V-102 screen grid dropping	RC30BF333K		RC30BF333K	R-108	1
R-109	Same as R-105.	V-102 plate decoupling					
R-110	RESISTOR, variable: composition; 25,000 ohms $\pm 20\%$; 2 w, 70°C max continuous operation; 3 tinned term; enclosed metal case $1\frac{1}{16}$ " diam x $\frac{3}{16}$ " d; round metal shaft 0.250" diam x $\frac{3}{4}$ " min lg; mfr taper B, less than 1 per cent of total resistance ins contact arm, without off position; normal torque; mtg bushing $\frac{3}{8}$ "-32 thd x $\frac{3}{8}$ " lg, 2 non-turn devices on $1\frac{1}{32}$ " rad at 3 and 9 o'clock, one used; must not contain any materials nutrient for fungi, resistant salt spray.	RF GAIN control	-637037-M20	AB type "J" per Haz RM11RC253BM	RM11RC253BM	R-110	1
R-111	RESISTOR, fixed: composition; 100,000 ohms $\pm 10\%$; $\frac{1}{2}$ w; spec JAN-R-11.	V-103 grid leak	RC21BF104K		RC21BF104K	R-111, R-123	1
R-112	RESISTOR, fixed: composition; 15,000 ohms $\pm 10\%$; $\frac{1}{2}$ w; spec JAN-R-11.	V-103 screen grid voltage divider	RC21BF153K		RC21BF153K	R-112	1
R-113	RESISTOR, fixed: composition; 12,000 ohms $\pm 10\%$; $\frac{1}{2}$ w; spec JAN-R-11.	V-103 screen grid voltage divider	RC21BF123K		RC21BF123K	R-113	1
R-114	Same as R-105.	V-103 plate decoupling					
R-115	RESISTOR, fixed: composition; 2700 ohms $\pm 5\%$; $\frac{1}{2}$ w; spec JAN-R-11; (p/o L-115; for reference only).	V-103 plate load shunt	RC20BF272J		RC20BF272J	R-115	0
R-116	Not used.						
R-117	RESISTOR, fixed: composition; 47,000 ohms $\pm 10\%$; $\frac{1}{2}$ w; spec JAN-R-11.	V-104 grid return	RC21BF473K		RC21BF473K	R-117	1
R-118	Same as R-103.	V-104 cathode bias					
R-119	Same as R-105.	V-104 screen grid decoupling					

PARTS LISTS

NAVSHIPS 91131
OCT-2 and OCT-3Section 8
R-104—R-119

8-19

TABLE 8-4. COMBINED PARTS AND SPARE PARTS LIST—Cont'd

SYMBOL DESIG.	NAME OF PART AND DESCRIPTION	FUNCTION	PARTS				SPARE PARTS
			JAN OR NAVY TYPE DESIG.	MFR. AND MFR'S. DESIG.	HAZELTINE PART/DWG NUMBER	ALL SYMBOL DESIGNATIONS INVOLVED	EQUIP. QUAN.
R-120	RESISTOR, variable: composition; 10,000 ohms $\pm 20\%$; 2 w, 70°C max continuous operation; 3 tinned term; enclosed metal case $1\frac{1}{16}$ " diam x $\frac{9}{16}$ " d; metal locking shaft 0.250" diam x $\frac{5}{8}$ " min lg; linear; ins cont arm, without off position; normal torque; mtg bushing $\frac{3}{8}$ " lg w/thd $\frac{3}{8}$ "-32 x $\frac{1}{2}$ " lg, 2 non-turn devices on $1\frac{1}{32}$ " rad at 3 and 9 o'clock, one used; resistant to salt spray, must not contain materials nutrient for fungi.	Limiter output adjustment	-635897-L20	AB type "J" per Haz RM11LB103UM	RM11LB103UM	R-120	1
R-121	Same as R-105.	V-104 plate decoupling					
R-122	RESISTOR, fixed: composition; 10,000 ohms $\pm 10\%$; $\frac{1}{2}$ w; spec JAN-R-11.	V-104 screen grid voltage divider	RC21BF103K		RC21BF103K	R-122	1
R-123	Same as R-111.	V-105 output r-f filter					
R-124	RESISTOR, fixed: composition; 1000 ohms $\pm 5\%$; $\frac{1}{2}$ w; spec JAN-R-11.	V-106A cathode coupling capacitor discharging	RC21BF102J		RC21BF102J	R-124	1
R-125	RESISTOR, fixed: composition; 1 meg $\pm 10\%$; $\frac{1}{2}$ w; spec JAN-R-11.	V-105 cathode load	RC21BF105K		RC21BF105K	R-125, R-126	1
R-126	Same as R-125.	V-105 cathode load					
R-127	RESISTOR, fixed: composition; 47,000 ohms $\pm 5\%$; $\frac{1}{2}$ w; spec JAN-R-11.	V-106A cathode load	RC21BF473J		RC21BF473J	R-127	1
R-128	RESISTOR, fixed: composition; 1.8 meg $\pm 5\%$; $\frac{1}{2}$ w; spec JAN-R-11.	V-105 output voltage divider	RC21BF185J		RC21BF185J	R-128	1
R-129	Not used.						
R-130	RESISTOR, variable: composition; 10,000 ohms $\pm 20\%$; 2 w, 70°C max continuous operation; 3 tinned term; enclosed metal case $1\frac{1}{16}$ " diam x $\frac{9}{16}$ " d; round metal shaft 0.250" diam x $\frac{3}{4}$ " min lg; linear taper; ins cont arm, without off position; normal torque; mtg bushing $\frac{3}{8}$ "-32 thd x $\frac{3}{8}$ " lg, 2 non-turn devices on $1\frac{1}{32}$ " rad at 3 and 9 o'clock, one used; must not contain materials nutrient for fungi, resistant to salt spray.	AUDIO GAIN control	-633503-M20	AB type "J" per Haz RM11RC103UM	RM11RC103UM	R-130	1

R-131	RESISTOR, fixed: composition; 4.7 meg $\pm 10\%$; $\frac{1}{2}$ w; spec JAN-R-11.	V-107 anode return	RC21BF475K		RC21BF475K	R-131	1
R-132	RESISTOR, fixed: composition; 100,000 ohms $\pm 5\%$; $\frac{1}{2}$ w; spec JAN-R-11.	V-107 rectification linearity	RC21BF104J		RC21BF104J	R-132, R-139, R-146	2
R-133	RESISTOR, fixed: composition; 10 meg $\pm 5\%$; $\frac{1}{2}$ w; spec JAN-R-11.	V-107 anode load	RC21BF106J		RC21BF106J	R-133	1
R-134	Not used.						
R-135	RESISTOR, variable: composition; 50,000 ohms $\pm 10\%$; 2 w, 70°C max continuous operation; 3 tinned term; enclosed metal case $1\frac{1}{16}$ " diam x $\frac{3}{16}$ " d; round screwdriver adjustment shaft, metal, 0.250" diam x $\frac{5}{8}$ " min length; linear taper; ins cont arm, without off position; normal torque; furnished w/shaft locking nut; mtg bushing $\frac{3}{8}$ "-32 x $\frac{1}{2}$ " lg, 2 non-turn devices on $1\frac{1}{32}$ " rad at 3 and 9 o'clock, one used; resistant to salt water spray, must not contain materials nutrient for fungi.	Meter Zero Unkeyed adjustment	-635764-L10	AB type "J" per Haz RM11LB503UK	RM11LB503UK	R-135	1
R-136	RESISTOR, fixed: composition; 270,000 ohms $\pm 5\%$; $\frac{1}{2}$ w; spec JAN-R-11.	Meter zero bias voltage divider	RC21BF274J		RC21BF274J	R-136	1
R-137	Not used.						
R-138	Not used.						
R-139	Same as R-132.	V-107 output bias voltage divider					
R-140	RESISTOR, variable: composition; 50,000 ohms $\pm 10\%$; 2 w, 70°C max continuous operation; 3 tinned term; enclosed metal case $1\frac{1}{16}$ " diam x $\frac{9}{16}$ " d; round metal shaft 0.250" diam x $\frac{3}{4}$ " lg min lg; linear taper; ins cont arm, without off position; normal torque; mtg bushing $\frac{3}{8}$ "-32 thd x $\frac{3}{8}$ " lg, 2 non-turn devices on $1\frac{1}{32}$ " rad at 3 and 9 o'clock, one used; must not contain materials nutrient for fungi, resistant to salt spray.	METER ZERO SET control	-631234-M10	AB type "J" per Haz RM11RC503UK	RM11RC503UK	R-140	1
R-141	RESISTOR, fixed: composition; 68,000 ohms $\pm 5\%$; $\frac{1}{2}$ w; spec JAN-R-11.	V-107 output bias	RC21BF683J		RC21BF683J	R-141	1
R-142	RESISTOR, fixed: composition; 1.5 meg $\pm 5\%$; $\frac{1}{2}$ w; spec JAN-R-11.	V-107 output voltage divider	RC21BF155J		RC21BF155J	R-142	1

TABLE 8-4. COMBINED PARTS AND SPARE PARTS LIST—Cont'd

PARTS							SPARE PARTS
SYMBOL DESIG.	NAME OF PART AND DESCRIPTION	FUNCTION	JAN OR NAVY TYPE DESIG.	MFR. AND MFR'S. DESIG.	HAZELTINE PART/DWG NUMBER	ALL SYMBOL DESIGNATIONS INVOLVED	EQUIP. QUAN.
R-143	RESISTOR, variable: composition; 1 meg $\pm 20\%$; 2 w; 3 tinned term; body $1\frac{1}{16}$ " diam x $\frac{3}{16}$ " d, locking shaft $\frac{1}{4}$ " diam x $\frac{5}{8}$ " lg; linear taper; enclosed body; furnished w/lock nut; bushing $\frac{3}{8}$ "-32 thd x $\frac{1}{2}$ " lg; bakelite parts must not contain fungi nutrients, screw driver slot.	Meter Sensitivity Unkeyed adjustment	-631985-20	AB type "J" per Haz RM11LB105UM	RM11LB105UM	R-143	1
R-144	RESISTOR, fixed: composition; 130,000 ohms $\pm 5\%$; $\frac{1}{2}$ w; spec JAN-R-11.	V-106B cathode load	RC20BF134J		RC20BF134J	R-144	1
R-145	RESISTOR, variable: composition; 25,000 ohms $\pm 20\%$; 2 w, 70°C max continuous operations; 3 tinned term; enclosed metal case $1\frac{1}{16}$ " diam x $\frac{3}{16}$ " d; round metal shaft 0.250" diam x $\frac{3}{4}$ " min lg; linear taper; ins cont arm, without off position; normal torque; mtg bushing $\frac{3}{8}$ " 32 thd x $\frac{3}{8}$ " lg, 2 non-turn devices on $1\frac{1}{32}$ " rad at 3 and 9 o'clock, one used; must not contain any materials nutrient for fungi, resistant to salt spray.	METER CALIB. control	-631302-M20	AB type "J" per Haz RM11RC253UM	RM11RC253UM	R-145	1
R-146	Same as R-132.	Meter return voltage divider					
R-147	RESISTOR, fixed: composition; 160,000 ohms $\pm 5\%$; $\frac{1}{2}$ w; spec JAN-R-11.	Meter return voltage divider	RC21BF164J		RC21BF164J	R-147	1
R-148	RESISTOR, fixed: composition; 560,000 ohms $\pm 5\%$; $\frac{1}{2}$ w; spec JAN-R-11.	Meter return current limiting	RC21BF564J		RC21BF564J	R-148	1
R-149	RESISTOR, variable: composition; 250,000 ohms $\pm 20\%$; 2 w, 70°C max continuous operation; 3 tinned term; enclosed metal case $1\frac{1}{16}$ " diam x $\frac{3}{16}$ " d; round, screwdriver adjustment locking shaft, metal, 0.250" diam x $\frac{5}{8}$ " min lg; linear taper; ins cont arm, without off position; normal torque; furnished w/shaft locking nut; mtg bushing $\frac{3}{8}$ "-32 x $\frac{1}{2}$ " lg, 2 non-turn devices on $1\frac{1}{32}$ " rad at 3 and 9 o'clock, one used; resistant to salt water spray, must not contain materials nutrient for fungi.	Tune Mark Adjust	-635957-L20	AB type "J" per Haz RM11LB254UM	RM11LB254UM	R-149	1
R-150	Not used.						

ORIGINAL

ORIGINAL

R-151	RESISTOR, fixed: composition; 1800 ohms $\pm 10\%$; $\frac{1}{2}$ w; spec JAN-R-11.	V-108 output voltage divider	RC21BF182K		RC21BF182K	R-151, R-152	1
R-152	Same as R-151.	V-108 output voltage divider					
R-153	RESISTOR, fixed: composition; 82,000 ohms $\pm 10\%$; $\frac{1}{2}$ w; spec JAN-R-11.	V-108 output voltage divider	RC21BF823K		RC21BF823K	R-153, R-154, R-155	2
R-154	Same as R-153.	V-108 output voltage divider					
R-155	Same as R-153.	V-108 grid return					
R-156	RESISTOR, fixed: composition; 220 ohms $\pm 10\%$; $\frac{1}{2}$ w; spec JAN-R-11.	V-108 cathode bias	RC21BF221K		RC21BF221K	R-156	1
R-157 through R-161	Not used.						
R-162	RESISTOR, fixed: composition; 18,000 ohms $\pm 10\%$; $\frac{1}{2}$ w; spec JAN-R-11.	V-109 grid return	RC21BF183K		RC21BF183K	R-162	1
R-163	Same as R-105.	V-109 screen grid decoupling					
R-164	Same as R-105.	V-109 plate decoupling					
R-165	RESISTOR, variable: composition; 5000 ohms $\pm 20\%$; 2 w, 70°C max continuous operation; 3 tinned term; enclosed metal case $1\frac{1}{16}$ " diam x $\frac{9}{16}$ " d; round metal shaft 0.250" diam x $\frac{3}{4}$ " min lg; linear taper; ins cont arm, without off position; normal torque; mtg bushing $\frac{3}{8}$ "-32 thd x $\frac{3}{8}$ " lg, 2 non-turn devices on $1\frac{1}{32}$ " rad at 3 and 9 o'clock, one used; must not contain any materials nutrient for fungi, resistant to salt spray.	FINE TUNING control	-631667-M20	AB type "J" per Haz RM11RC502UM	RM11RC502UM	R-165	1
R-166	RESISTOR, fixed: composition; 120,000 ohms $\pm 10\%$; $\frac{1}{2}$ w; spec JAN-R-11.	V-110 grid return	RC20BF124K		RC20BF124K	R-166	1
R-167	RESISTOR, fixed: composition; 270 ohms $\pm 10\%$; $\frac{1}{2}$ w; spec JAN-R-11.	V-110 cathode bias	RC21BF271K		RC21BF271K	R-167	1
R-168	RESISTOR, fixed: composition; 56,000 ohms $\pm 10\%$; $\frac{1}{2}$ w; spec JAN-R-11.	V-110 screen grid dropping	RC21BF563K		RC21BF563K	R-168	1
R-169	Same as R-105.	V-110 plate decoupling					
R-170 through R-179	Not used.						
R-180	RESISTOR, fixed: WW; 4000 ohms $\pm 5\%$; 6 w; spec JAN-R-26.	V-111 anode voltage dropping	RW21E402		RW21E402	R-180	1

PARTS LISTS

NAVSHIPS 91131
OCT-2 and OCT-3Section 8
R-151-R-180

8-23

TABLE 8-4. COMBINED PARTS AND SPARE PARTS LIST—Cont'd

PARTS							SPARE PARTS
SYMBOL DESIG.	NAME OF PART AND DESCRIPTION	FUNCTION	JAN OR NAVY TYPE DESIG.	MFR. AND MFR'S. DESIG.	HAZELTINE PART/DWG NUMBER	ALL SYMBOL DESIGNATIONS INVOLVED	EQUIP. QUAN.
R-181	RESISTOR, fixed: composition; 39 ohms $\pm 10\%$; 2 w; spec JAN-R-11.	V-106, V-107, V-109 heater shunt	RC41BF390K		RC41BF390K	R-181	1
	(S) SWITCHES						
S-101	SWITCH, rotary: 2 poles, 3 positions; single sect; spring silver alloy cont, solid coin silver rotor blades; ceramic wafer; $1\frac{1}{8}$ " lg x $1\frac{15}{16}$ " diam, incl $\frac{1}{8}$ " lg shaft and mtg bushing; non-shortening type rotor blades; normally closed; solder lug term; $\frac{3}{8}$ "-32 thd single hole mtg bushing $\frac{3}{8}$ " lg; stops provided both ends of travel, unit resistant to salt spray, ceramic wafer moisture proof.	Consists of S-101A, S-101B		Oak type DHC	SW-1124-2	S-101, S-101A, S-101B	1
S-101A	Part of S-101.	MONITOR-CALIB. switch					
S-101B	Part of S-101.	MONITOR-CALIB. switch					
S-102	SWITCH, rotary: 3 poles, 4 positions single sect; spring silver alloy cont, solid coin silver rotor blades; ceramic wafer; $3\frac{3}{16}$ " lg x $1\frac{15}{16}$ " diam, incl $\frac{1}{8}$ " lg shaft and mtg bushing; non-shortening type rotor blades; normally closed; solder lug term; $\frac{3}{8}$ "-32 thd single hole mtg bushing $\frac{3}{8}$ " lg; stops to be provided at both ends of travel, unit resistant to salt spray, ceramic wafer moisture proof.	Consists of S-102A, S-102B, S-102C		Oak type DHC	SW-1123-2	S-102, S-102A, S-102B S-102C	1
S-102A	Part of S-102.	BAND switch					
S-102B	Part of S-102.	BAND switch					
S-102C	Part of S-102.	BAND switch					
S-103 through S-109	Not used.						

S-110	SWITCH, toggle: DPDT, 2 position; 30 amp, 30 v DC; bakelite body; $\frac{9}{64}$ " wd x $1\frac{21}{64}$ " h x $2\frac{7}{32}$ " d overall; $1\frac{1}{16}$ " lg bat type handle; ON-ON locking action, normally closed; solder lug term; single hole mtg bushing $1\frac{5}{32}$ "-32 thd, $1\frac{5}{32}$ " lg; furnished w/mtg hardware; spec JAN-S-23.	POWER switch	ST52N		SW-10012-2	S-110, S-111	1
S-111	Same as S-110.	T-104 primary voltage selector					
S-112 through S-129	Not used.						
S-130	SWITCH, rotary: 4 poles, 3 positions; 2 sect; spring silver alloy cont, solid coin silver rotor blades; ceramic wafers; $2\frac{1}{4}$ " lg x $1\frac{15}{16}$ " diam, incl $\frac{7}{8}$ " lg shaft and mtg bushing; non-shorting type cont; normally closed; solder lug term; single hole mtg bushing $\frac{3}{8}$ "-32 thd x $\frac{3}{8}$ " lg; stops provided both ends of travel, unit resistant to salt spray, ceramic wafers moisture proof.	Consists of C-130A, C-130B, C-130C, C-130D		Oak type DHC	SW-1129-2	S-130, S-130A, S-130B, S-130C, S-130D	1
S-130A	Part of S-130.	TUNE-MEAS. switch					
S-130B	Part of S-130.	TUNE-MEAS. switch					
S-130C	Part of S-130.	TUNE-MEAS. switch					
S-130D	Part of S-130.	TUNE-MEAS. switch					
(T) TRANSFORMERS							
T-101	TRANSFORMER, IF: peak freq 912 kc; interstage; shielded; $4\frac{1}{8}$ " h x $1\frac{1}{16}$ " sq overall; two slug tuning devices, one ea end; adj iron core tuning; two #4-40 thd mtg studs $1\frac{5}{16}$ " c to c; 4 solder lug term; incl JAN fixed capacitor CM20C181J.	IF input transformer	-472317	Guthman per Haz A-4661	A-4661	T-101, T-102	2
T-102	Same as T-101.	IF interstage transformer					
T-103	TRANSFORMER, IF: peak freq 912 kc; discriminator; shielded; $4\frac{1}{8}$ " h x $2\frac{1}{4}$ " wd x $1\frac{9}{16}$ " d overall; solid phenolic core; double tuned; dual variable capacitor tuned; two #6-32 thd spade mtg studs $1\frac{21}{32}$ " c to c; 6 solder lug term; incl 3 JAN fixed capacitors CM20C271K, CC36CG680J; CC21RH270J, one multiple wound coil, Hazeltine Elec #A-4754, one dual variable capacitor, Hazeltine Elec #CV-1018.	Discriminator transformer	-472322	Sickles FW per Haz A-4662	A-4662	T-103	1

TABLE 8-4. COMBINED PARTS AND SPARE PARTS LIST—Cont'd

PARTS							SPARE PARTS
SYMBOL DESIG.	NAME OF PART AND DESCRIPTION	FUNCTION	JAN OR NAVY TYPE DESIG.	MFR. AND MFR'S. DESIG.	HAZELTINE PART/DWG NUMBER	ALL SYMBOL DESIGNATIONS INVOLVED	EQUIP. QUAN.
T-104	TRANSFORMER, power: distribution; unit per JAN-T-27, class "A" grade 1; 0.1 kva, 50/60 cps, single ph; pri term #1-2 115 v, #3-4 115 v; three output windings, two windings CT; sec'd term #5-6 5.0 v 3.0 amp, #7-8-9 CT 350 v RMS 0.056 amp RMS and 350 v RMS 0.056 amp RMS, #10-11-12 CT 6.3 v 3.0 amp and 6.3 v 3.0 amp; filled w/asphalt base compound; w/melting point 300°F; hermetically sealed metallic case, gray enamel finish; 5" h x 3 $\frac{3}{4}$ " wd x 3 $\frac{3}{16}$ " d, less term and mtg studs; 12 slotted term on ceramic bushings, located on bottom $\frac{1}{2}$ " h; four $\frac{1}{4}$ "-20 thd mtg studs on 2 $\frac{3}{4}$ " x 2 $\frac{1}{2}$ " mtg/c; 190° to 200°F water immersion test for 2 minutes spec JAN-T-27.	Power transformer	-304676	Freed Trans per Haz TR-1128	TR-1128	T-104	1
(TB) TERMINAL BOARDS							
TB-101	SUB-ASSEMBLY: component mtg board; 32 term pins, phenolic board; 5 $\frac{1}{16}$ " lg x 2 $\frac{7}{8}$ " wd x $\frac{7}{8}$ " h overall; two #6-32 thd tap mtg posts 4.750" c to c; incl C-162, C-163, C-164, C-167, C-168, C-169, L-165, L-170, R-162, R-164, R-166, R-167, R-168, R-169.	Component mtg		Hazeltine Elec part/dwg A-4634	A-4634	TB-101	0
TB-102	SUB-ASSEMBLY: component mtg board; 24 term pins, phenolic board; 3 $\frac{3}{8}$ " lg x 2 $\frac{1}{4}$ " wd x 1 $\frac{3}{16}$ " h overall; two #6-32 thd tap mtg inserts 1 $\frac{1}{32}$ " lg; incl R-124, R-127, R-131, R-132, R-128 R-136, R-139, R-141, R-142, R-144, R-146, R-147, R-148.	Component mtg		Hazeltine Elec part/dwg A-4666	A-4666	TB-102	0
TB-103	SUB-ASSEMBLY: component mtg board; 6 term pins, phenolic board; 2 $\frac{1}{4}$ " lg x 1 $\frac{1}{16}$ " wd x 1 $\frac{9}{32}$ " h overall; two #6-32 thd tap mtg inserts 1 $\frac{1}{32}$ " lg; incl R-103, R-104, R-105.	Component mtg		Hazeltine Elec part/dwg A-4669	A-4669	TB-103	0

TB-104	SUB-ASSEMBLY: component mtg board; 33 term pins, phenolic board; $7\frac{3}{8}$ " lg x $2\frac{3}{4}$ " wd x $1\frac{9}{32}$ " h overall; four #6-32 thd tap inserts $1\frac{1}{32}$ " lg; incl C-112, C-115, C-117, C-125, C-126, C-127, L-103, L-115, R-107, R-108, R-109, R-112, R-113, R-114, R-117, R-118, R-119, R-121, R-122, R-123, R-125, R-126.	Component mtg		Hazeltine Elec part/dwg A-4670	A-4670	TB-104	0
TB-105	SUB-ASSEMBLY: component mtg board; 24 term pins, phenolic term board; $7\frac{1}{2}$ " lg x $1\frac{3}{4}$ " wd x $\frac{7}{8}$ " h overall; three 0.157" diam mtg holes; incl C-151, C-152, C-153, C-154, C-157, C-158, C-159, R-106, R-151, R-152, R-153, C-154, R-155, R-163, R-181,	Component mtg		Hazeltine Elec part/dwg A-4667	A-4667	TB-105	0
TB-106	SUB-ASSEMBLY: component mtg board; 3 term pins, 2 term lugs, phenolic term board; $3\frac{1}{8}$ " lg x $2\frac{3}{4}$ " wd x $1\frac{9}{32}$ " h overall; incl C-144, C-145, L-144, L-145.	Component mtg		Hazeltine Elec part/dwg A-4882	A-4882	TB-106	0
(V) VACUUM TUBES							
V-101	TUBE, electron: miniature pentagrid converter.	Mixer	JAN-6BE6		TU-1083	V-101	3
V-102	TUBE, electron: miniature RF amplifier pentode, remote cutoff.	IF amplifier	JAN-6BA6		TU-1084	V-102	3
V-103	TUBE, electron: receiving pentode amplifier, a miniature version of 6SH7.	First limiter	JAN-6AU6		TU-10093	V-103, V-104, V-109	9
V-104	Same as V-103.	Second limiter					
V-105	TUBE, electron: VHF twin diode.	Discriminator	JAN-6AL5		TU-10009	V-105, V-107	6
V-106	TUBE, electron: dual triode.	Consists of V-106A, V-106B	JAN-12AX7		TU-1086	V-106, V-106A, V-106B	3
V-106A	Part of V-106.	Buffer					
V-106B	Part of V-106.	Meter amplifier					
V-107	Same as V-105.	Meter rectifier					
V-108	TUBE, electron: HF twin triode.	Calibrating oscillator	JAN-6J6		TU-10014	V-108	3
V-109	Same as V-103.	Local oscillator					
V-110	TUBE, electron: high-transconductance, sharp cut-off, miniature pentode.	Frequency multiplier	JAN-6AH6		TU-10098	V-110	3
V-111	TUBE, electron: voltage regulator.	Voltage regulator	JAN-OC3/VR105		TU-10045	V-111	2
V-112	TUBE, electron: full-wave high-vacuum rectifier.	Rectifier	JAN-5Y3GT/G		TU-10007	V-112	2

TABLE 8-4. COMBINED PARTS AND SPARE PARTS LIST—Cont'd

PARTS							SPARE PARTS
SYMBOL DESIG.	NAME OF PART AND DESCRIPTION	FUNCTION	JAN OR NAVY TYPE DESIG.	MFR. AND MFR'S. DESIG.	HAZELTINE PART/DWG NUMBER	ALL SYMBOL DESIGNATIONS INVOLVED	EQUIP. QUAN.
V-113	TUBE, ballast: glass; 0.98-1.05 amp, 4.5-10 v drop; T-9 bulb, 3 $\frac{3}{16}$ " lg x 1 $\frac{1}{8}$ " diam overall; std octal base, connections to pins #2 and #7. (W) WIRES	Ballast		Amperite part 10-4D	VR-1002	V-113	1
W-201	CABLE ASSEMBLY, power: Navy type DCOP-2 cable; 11' 10 $\frac{3}{4}$ " lg excluding terminations; connector-receptacle Navy type -491077 one end, connector-plug Navy type -49825 other end; used w/models OCT-2 and OCT-3 equipments. (X) SOCKETS	Models OCT-2 and OCT-3 power cable assem	-62450 (12' 0")	Hazeltine Elec part/dwg A-4949	A-4949	W-201	1
X-101	SOCKET, tube: 7 miniature cont; one-piece mtg saddle; two 0.125" diam mtg holes $\frac{1}{8}$ " c to c; round ceramic body 0.625" diam, extends $\frac{1}{32}$ " below steel mtg saddle, 1 $\frac{1}{32}$ " h x 1 $\frac{1}{8}$ " across mtg saddle overall; phosphor bronze, silver pl cont; outer shield $\frac{3}{4}$ " h, center shield 0.095" ID locating tab or notch on shell between cont #1 and #7, insulation fungicidal treated, center shield and shell wired together to gnd; spec JAN-S-28.	V-101 socket	SO10C		SO10C	X-101, X-102, X-103 X-104, X-105, X-107, X-108, X-109, X-110	5
X-102	Same as X-101.	V-102 socket					
X-103	Same as X-101.	V-103 socket					
X-104	Same as X-101.	V-104 socket					
X-105	Same as X-101.	V-105 socket					
X-106	SOCKET, tube: noval miniature spring clip cont; one piece saddle mtg; two $\frac{1}{8}$ " diam mtg holes on 1 $\frac{1}{8}$ " mtg/c; round molded mica filled phenolic body, dimen incl shield base 0.940" diam x $\frac{29}{64}$ " lg, less cont, saddle 1 $\frac{11}{16}$ " lg; beryllium-copper cont, silver pl; 0.102" I.D. center shield, 2 wire holes on end.	V-106 socket	-491819	Cinch part 52F12875	SO-10050	X-106	1
X-107	Same as X-101.	V-107 socket					
X-108	Same as X-101.	V-108 socket					

ORIGINAL

X-109	Same as X-101.	V-109 socket					
X-110	Same as X-101.	V-110 socket					
X-111	SOCKET, tube: std octal, has 4 gnd lugs equally spaced w/0.078" diam holes; one-piece cadmium pl steel saddle mtg; two #6-32 thd bushings $\frac{1}{8}$ " lg welded to saddle $1\frac{1}{2}$ " c to c; $1\frac{25}{64}$ " lg x $\frac{1}{2}$ " h overall, circular ceramic body; phosphor bronze cont, silver pl; ceramic base per spec JAN-I-10, grade L-3 or better, phosphor bronze cont per Navy spec 46B14, subject to 100 hr salt spray test, insulation fungicidal treated.	V-111 socket	-491841	Ucinite part 115215	SO-10028	X-111, X-112, X-113	2
X-112	Same as X-111.	V-112 socket					
X-113	Same as X-111.	V-113 socket					
	(XF) SOCKETS						
XF-101	HOLDER, fuse: cylindrical post w/bayonet type plug; for single fuse of type 3 AG or $\frac{1}{4}$ " x $1\frac{1}{4}$ " overall dimen; type SFE20, ACM, MDL, MTH; molded black phenolic body and plug; 15 amp normal current capacity, used w/25 v and 250 v fuses; $2\frac{1}{16}$ " lg x $1\frac{1}{16}$ " diam; $\frac{1}{2}$ "-24 thd bushing for single hole mtg, flat for keying, furnished w/hardware; 2 solder lug term, one on end, one on side; test probe hole in plug, must not contain any materials nutrient for fungi.	F-101 holder		Buss type HKM	FU-10010-2	XF-101, XF-102, XF-103, XF-104	1
XF-102	Same as XF-101.	F-102 holder					
XF-103	Same as XF-101.	F-103 holder					
XF-104	Same as XF-101.	F-104 holder					
XF-105	CLIP: fuse; phosphor bronze, nickel pl; not insulated; for use w/250 v 3 amp fuse; spring clip action; max jaw opening $\frac{1}{4}$ " diam; one 0.134" diam mtg hole through base.	H-201 holder		Littlefuse cat 1011	FC-10003	XF-105	0

TABLE 8-4. COMBINED PARTS AND SPARE PARTS LIST—Cont'd

PARTS							SPARE PARTS
SYMBOL DESIG.	NAME OF PART AND DESCRIPTION	FUNCTION	JAN OR NAVY TYPE DESIG.	MFR. AND MFR'S. DESIG.	HAZELTINE PART/DWG NUMBER	ALL SYMBOL DESIGNATIONS INVOLVED	EQUIP. QUAN.
XI-101	(XI) SOCKET LIGHT, indicator: (pilot); w/lens; $2\frac{1}{32}$ " diam red frosted lens; full dimout type; bayonet base for bulbs #44, #47, and NE-51; 500 v DC socket; enclosed brass shell; $2\frac{7}{32}$ " diam x $2\frac{5}{16}$ " lg o/a incl term; mounts by means of $1\frac{1}{16}$ "-27 thd bushing $\frac{1}{16}$ " lg; socket horizontally mtd, lamp replaceable from front of panel, two solder lug term on rear end; bakelite socket housing, contains no fungi nutrients, furnished in spares w/mtg hardware.	I-101 socket housing		Dialco part 12-2210-621	RC-10059-2	XI-101	1
XZ-101	(XZ) CRYSTAL SOCKET SOCKET, crystal: molded mykroy body, phosphor bronze cont, silver pl, retaining springs, beryllium copper; 3 spring clip cont; oval shape, $2\frac{1}{32}$ " lg x $1\frac{5}{8}$ " wd x $\frac{9}{32}$ " h overall; two 0.172" diam mtg holes $12\frac{7}{32}$ " c to c.	Z-101 socket	-491369-A	Elec Mech type ETS-3	SO-1075	XZ-101	1
Z-101	(Z) IMPEDANCES CRYSTAL UNIT, quartz: 2 xtal pl; freq plate "A" 1000 kc ± 1 kc, freq plate "B" 1000 kc ± 1 kc plus 1000 cps ± 50 cps, freq "A" and "B" are variable capacitor adjustable to have difference of 1000 cps ± 10 cps and maintain 1000 cps difference -15°C to $+70^{\circ}\text{C}$ temp range; 3 pins unequally spaced on bottom, 0.156" diam x $\frac{37}{64}$ " lg, xtal "A" pin, xtal "B" pin, one common pin, rectangular body $2\frac{3}{16}$ " h x $1\frac{5}{8}$ " wd x $1\frac{3}{8}$ " d less pins; spec JAN-C-16A as applicable to this xtal unit, Navy dwg XA-8848E.	Consists of Z-101A, Z-101B	-40323	Crystal type XL-5	XL-1004	Z-101, Z-101A, Z-101B	1
Z-101A	Part of Z-101.	V-108 frequency control					
Z-101B	Part of Z-101.	V-108 frequency control					

TABLE 8-5. CROSS REFERENCE PARTS LIST

Designation	Key Symbol	Designation	Key Symbol
JAN TYPES		JAN TYPES—Cont'd.	
CC21CK020D	C-165	RC21BF185J	R-128
CC21SL220K	C-120	RC21BF221K	R-156
CC26HG270J	C-161	RC21BF223K	R-102
CM20C181J	C-111	RC21BF271K	R-167
CM20C221K	C-162	RC20BF272J	R-115
CM20C300K	C-159	RC21BF274J	R-136
CM20C470J	C-125	RC21BF332K	R-107
CM20C511J	C-167	RC21BF473J	R-127
CM25C102J	C-112	RC21BF473K	R-117
CM25E821G	C-115	RC21BF475K	R-131
CM35C102K	C-151	RC21BF563K	R-168
CM40C103J	C-127	RC21BF564J	R-148
CM40C103K	C-131	RC21BF683J	R-141
CP67BEG103X	C-106	RC21BF823K	R-153
CP69B5EF104X	C-107	RC30BF333K	R-108
CP69BB1EF504X	C-130	RC31BF104K	R-106
CP70E1EF405X	C-181	RC40BF153K	R-104
RC20BF124K	R-166	RC41BF390K	R-181
RC20BF134J	R-144	RC41BF680K	R-101
RC21BF102J	R-124	RW21E402	R-180
RC21BF102K	R-105	SOS3	E-105
RC21BF103K	R-122	SOS6	E-101
RC21BF104J	R-132	SO10C	V-101
RC21BF104K	R-111	ST52N	S-110
RC21BF105K	R-125	6AL5	V-105
RC21BF106J	R-133	6AH6	V-110
RC21BF123K	R-113	6AU6	V-103
RC21BF151K	R-103	6BA6	V-102
RC21BF153K	R-112	6BE6	V-101
RC21BF155J	R-142	6J6	V-108
RC21BF164J	R-147	12AX7	V-106
RC21BF182K	R-151	OC3/VR105	V-111
RC21BF183K	R-162	5Y3GT/G	V-112
NAVY TYPES		NAVY TYPES—Cont'd.	
-10708	A-302	-472327	L-104
-10709	A-401	-481973	C-102
-22731	M-101	-482062	C-155
-40323	Z-101	-483390-A	C-160
-49194	J-101	-484851	C-105
-49679	E-113	-49025-A	J-102
-49825	P-201	-491076	J-103
-60170	101-199	-491077	P-202
	series	-491369-A	XZ-101
-28032-2	F-101	-491678	E-112
-304676	T-104	-491819	V-106
-304685	L-181	-491841	V-111
-472317	T-101	-631234-M10	R-140
-472318	L-125	-631302-M20	R-145
-472319	L-115	-631667-M20	R-165
-472320	L-165	-631985-20	R-143
-472321	L-170	-633503-M20	R-130
-472322	T-103	-635764-L10	R-135
-472323	L-101	-635897-L20	R-120
-472324	L-102	-635957-L20	R-149
-472325	L-160	-637037-M20	R-110
-472326	L-103	TB14	I-101

TABLE 8-6. APPLICABLE COLOR CODES

CAPACITOR COLOR CODES

RMA 3-DOT COLOR CODE FOR MICA-DIELECTRIC CAPACITORS

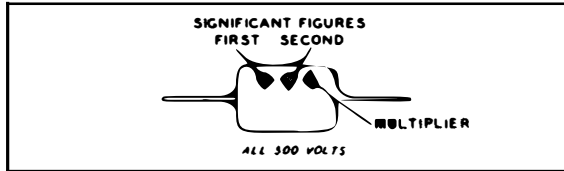

JAN 6-DOT COLOR CODE FOR PAPER-DIELECTRIC CAPACITORS

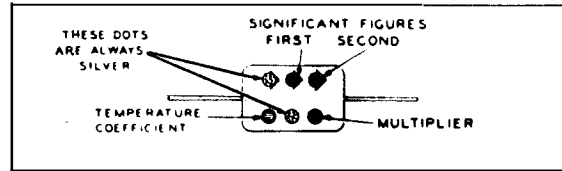

RMA 6-DOT COLOR CODE FOR MICA-DIELECTRIC CAPACITORS

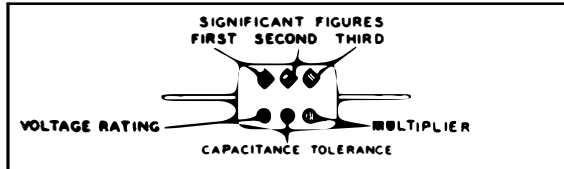

JAN 6-DOT COLOR CODE FOR MICA-DIELECTRIC CAPACITORS

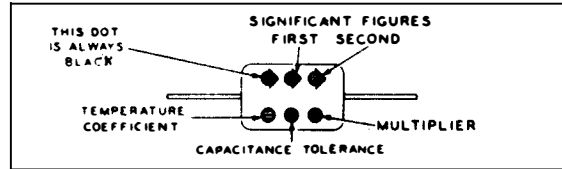

RMA COLOR CODE FOR TUBULAR CERAMIC-DIELECTRIC CAPACITORS

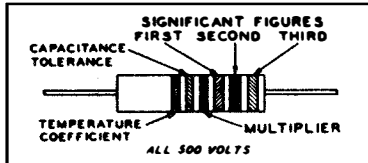

JAN COLOR CODE FOR FIXED CERAMIC-DIELECTRIC CAPACITORS

RADIAL TYPE NON-INSULATED

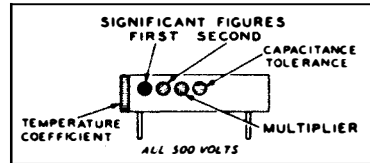

AXIAL TYPE INSULATED

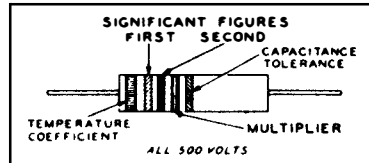

RMA: RADIO MANUFACTURERS ASSOCIATION
JAN: JOINT ARMY-NAVY

RESISTORS				CAPACITORS				
TOLERANCE	MULTIPLIER	SIGNIFICANT FIGURE	COLOR	MULTIPLIER			VOLTAGE RATING	TEMPERATURE COEFFICIENT
				RMA MICA AND CERAMIC-DIELECTRIC	JAN MICA AND PAPER-DIELECTRIC	JAN CERAMIC DIELECTRIC		
	1	0	BLACK	1	1	1		A
	10	1	BROWN	10	10	10	100	B
	100	2	RED	100	100	100	200	C
	1000	3	ORANGE	1000	1000	1000	300	D
	10000	4	YELLOW	10000			400	E
	100000	5	GREEN	100000			500	F
	1000000	6	BLUE	1000000			600	G
	10000000	7	VIOLET	10000000			700	
	100000000	8	GRAY	100000000		0.01	800	
	1000000000	9	WHITE	1000000000		0.1	900	
5	0.1		GOLD	0.1	0.1		1000	
10	0.01		SILVER	0.01	0.01		2000	
20			NO COLOR				500	

RESISTOR COLOR CODES

RMA COLOR CODE FOR FIXED COMPOSITION RESISTORS

AXIAL TYPE

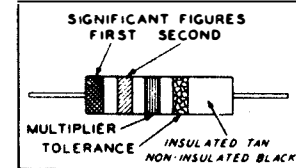

RADIAL TYPE

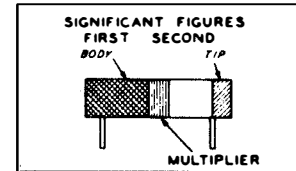

JAN COLOR CODE FOR FIXED COMPOSITION RESISTORS

AXIAL TYPE INSULATED

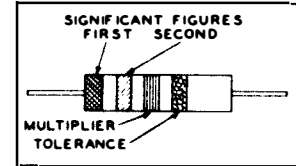

RADIAL TYPE NON-INSULATED

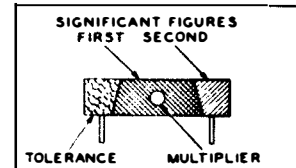

TABLE 8-7. LIST OF MANUFACTURERS

Abbreviations	Prefix	Name	Address
AB	CBZ	Allen-Bradley Co.	118 West Greenfield Ave., Milwaukee 4, Wisconsin
Allen Mfg	CAYT	The Allen Mfg. Co.	Hartford 1, Connecticut
Amperite	CAGK	Amperite Company	561 Broadway New York, N. Y.
Birtcher	CAIS	Birtcher Corp.	5087 Huntington Drive, Los Angeles 32, California
Buss	CFA	Bussman Mfg. Co.	Jefferson & University Sts., St. Louis 7, Missouri
Cal Inst	—	Calibrated Instrument	54 Franklin St., New York, N. Y.
Cardwell	—	Cardwell, Allen D., Mfg. Corp.	Brooklyn 1, New York
Cinch	CMG	Cinch Mfg. Co.	2335 W. Van Buren St., Chicago 12, Illinois
Crystal	CACE	Crystal Research Lab.	29 Allyn St., Hartford, Conn.
Dialco	CAYZ	Dial Light Co. of America, Inc.	900 Broadway New York 3, N. Y.
Elec Mech	CEZ	Electronics Mechanics, Inc.	70 Clifton Blvd., Clifton, N. J.
Freed Trans	CFX	Freed Transformer Company	72 Spring Street, New York, N. Y.
Guthman	CAUX	Edwin I. Guthman & Co.	15 South Throop St., Chicago, Ill.
Hammarlund	CHC	Hammarlund Mfg. Co., Inc.	460 W. 34th St., New York 1, N. Y.
*Hazeltine Elec	CHZ	Hazeltine Electronics Corp.	5825 Little Neck Parkway, Little Neck, L. I., N. Y.
Hart/Amertype	—	Hart, Frederick & Co., Inc. (Recordgraph Division)	Poughkeepsie, New York
Harnett Elec	CBEZ	Harnett Elec. Corp.	138 Haven Ave., Port Washington, L. I., N. Y.
Hubbell	CHU	Hubbell, Harvey, Inc.	1930 Thomas St., Bridgeport 2, Conn.
Ind Proa	CARO	Industrial Prod. Co.	Danbury, Connecticut
Littelfuse	CLF	Littelfuse, Inc.	4757 No. Ravenswood Ave., Chicago 40, Illinois
LN Barry	CAYU	L. N. Barry Co.	489 Main St., Cambridge 42, Mass.
Mallory	CMA	Mallory P. R. & Co., Inc.	3029 E. Washington St., Indianapolis 6, Indiana
Natl Co	CNA	National Co., Inc.	61 Sherman St., Malden, Mass.
Oak	COC	Oak Manufacturing Co.	1260 Clybourn Ave., Chicago 10, Ill.
Precision	—	Precision Gear	444 W. 33rd St., New York, N. Y.
Sickles	CFW	Sickles, F. W., Co.	165 Front St., Chicopee, Mass.
Suffolk Prod	CBKK	Suffolk Products, Inc.	Woodvine & Scudder Ave., Northport, L. I., N. Y.
Ucinite	CUF	Ucinite Company	1 Nevada St., Newtonville, Mass.
Weston	CV	Weston Elec. Instrument Co.	614 Frelinghuysen Ave., Newark 5, N. J.

* When the manufacturer's designation is preceded by the abbreviation "Haz", it indicates that the acceptable manufacturer's designation is the contractor's part/drawing number that follows.



INDEX

SUBJECT	FIGURE OR TABLE	SECTION	PARAGRAPH
A			
A-c line fuses.....	5-1	5	2
A-c power source.....		3	3
Accessories—list of.....	1-1	1	3
Adjustments—			
alignment.....	7-3	7
installation.....	3-2	3	8
operational.....	4-1	4	3, 4
servicing.....	7-2	7	5
Alignment procedures.....	7-2	7
AN/OCT-2—equipment supplied.....	1-1	1	3
AN/OCT-3—equipment supplied.....	1-1	1	3
Approximate frequency calibration charts.....	4-2, 4-3	4	5c
Aural tuning indication.....	4-1	2, 4	2c
B			
Basic similarities of AN/OCT-2 and AN/OCT-3.....	1-1	1	7
Bench tests—			
adjustments.....	7-2	7
procedures.....	7-2	7
schedules.....	6-1	6	2
sequence.....	7	2
tuning and alignment.....	7-2	7
Block diagram—			
indicator circuits, keyed operation.....	2-4	2	11
indicator circuits, tune operation.....	2-2	2	9
indicator circuits, unkeyed operation.....	2-3	2	10
RF Monitor.....	2-1	2	2
RF Monitor, basic.....	1-2	1	2
typical frequency-shift.....	2-5	2	15
Bottom view of chassis.....	7-3	7
Bureau of Ships Manual—requirements of.....	6	2a
C			
Cable—			
connections diagram.....	3-3	3	6, 7, 8
fabrication instructions.....	3-4	3	6, 7, 8
Calibration—			
checks and adjustment.....	3	8
frequency charts.....	4-2, 4-3	4
procedure.....	4-1	4	3, 4
Capabilities—performance.....	1	8
Causes of trouble—servicing.....	7-1	7	6
Chart—			
frequency calibration.....	4-2, 4-3	4
lubrication.....	6-1	6	3
resistance and voltage.....	7-5	7	4c, 4d
routine check.....	5-1	5	1
trouble shooting.....	7-2	7	6
winding data.....	7-3	7
Chassis—			
bottom view.....	7-3	7
layout diagram.....	5-1	5
top view.....	7-2	7
Checks—			
bench test.....	7-2	7
calibration.....	4-1	4	3, 4
installation.....	3	8
tube.....	5-1	5, 7	3, 4b
Circuit analysis—			
see "Theory of Operation"			
Circuit diagram—			
see "Block, Schematic, or Wiring Diagram"			
Color Codes.....	8-6	8
Combined parts and spare parts list.....	8-4	8
Connections—cable.....	3-3	3	6, 7, 8
Contents—table of.....	Front Matter	(Page i)
Contractor.....	1	8c
Contractual guarantee.....	Front Matter	(Page v)
Controls—			
functions of.....	2	14
locations of.....	4-1	4	2
operational use of.....	4-1	4	2
Correction page.....	Front Matter	(Page C)
Cross reference list—parts.....	8-5	8
Coupling to transmitter.....	3	6d, 7b

SUBJECT	FIGURE OR TABLE	SECTION	PARAGRAPH
D			
Data—			
recording of	6	1
reference	1	8
winding	7-3	7
Diagrams—			
see "Block, Schematic, and Wiring"			
Dimensions and weights	1-1, 1-3	1	1, 5
Disassembly instructions	7	3
Discriminator	2	7
Drawings—			
see "List of Illustrations"			
E			
Effective pages	Front Matter	(Page A)
Equipment—			
alignment	7-2	7
bench tests	7-2	7
calibration	4-1	4	3, 4
required but not supplied	1-2	1	4
supplied	1-1	1	3
tube complement	1-4	1	6
F			
Fabrication—cable	3-4	3	6, 7, 8
Failure report	7-1	7
Frequency—			
bands	1	8h, 8i
calibration charts	4-2, 4-3	4
power source	3	3
Frequency shift—			
measurements	4-1	4	5, 6
Monitor OCT-2, equipment supplied	1-1	1	3
Monitor OCT-3, equipment supplied	1-1	1	3
see also "Monitor"			
Telegraph system—summary	2-5	2	15
Functions—			
see "Parts list"			
Fuses—			
locations and functions	5	2
replacement of	5	2
G			
Gain control—			
see "Controls"			
General—			
description	1
information summary	1	8
maintenance notes	6	1
trouble shooting notes	7	2
Guarantee—contractual	Front Matter	(Page v)
H			
Headphone monitoring	4-1	2, 4	2c
High-voltage supply	2	13
I			
I-f amplifier—			
alignment	7-2	7
circuit analysis	2	5, 6
limiters	2	6
Illustrations—list of	Front Matter	(Page iii)
Indicator circuit operation—			
keyed	2-4	2	11
tune	2-2	2	9
unkeyed	2-3	2	10
Information—general	1	9
Inspection—maintenance	7	2e
Isolation—trouble	7	4
Installation—			
procedures	3-1, 3-2	3	6, 7
record of	Front Matter	(Page v)
Interchangeability of major units	1	7
Introduction—general	1	1

SUBJECT	FIGURE OR TABLE	SECTION	PARAGRAPH
K			
Keyed operation—			
block and schematic diagram.....	2-4	2
circuit function.....	2	11
frequency-shift measurement.....	4-1	4	5, 6
Keying—frequency-shift.....	2-5	2	15
L			
List of—			
cross-reference parts.....	8-5	8
illustrations.....	Front Matter	(Page iii)
major units.....	8-3	8
manufacturers.....	8-7	8
tables.....	Front Matter	(Page iv)
Local oscillator.....	2	4
Localization—trouble.....	7	2
Location of—			
fuses.....	5	2
tubes.....	5-1	5	3
Lubrication—			
chart.....	6-1	6
procedure.....	6-1	6	3
M			
Main Signal channel.....	2	2
Maintenance—			
bench tests.....	7-2	7
notes.....	6, 7	2, 2
procedures.....	7	1
test schedule.....	6-1	6	2
Major units—			
interchangeability.....	1	7
list of.....	8-3	8
Manufacturers—list of.....	8-7	8
Measurement—			
approximate frequency.....	4-2, 4-3	4	1, 2
calibration.....	4-1	4	3, 4
frequency-shift.....	4-1	4	5, 6
keyed signal.....	4-1	4	6
unkeyed signal.....	4-1	4	5
Monitor—			
alignment.....	7-2	7
bench tests.....	7-2	7
bottom view.....	7-2	7
controls.....	4-1	2, 4	14, 2
OCT-2, equipment supplied.....	1-1	1	3
OCT-3, equipment supplied.....	1-1	1	3
operational procedures.....	4-1	4	2
top view.....	7-2	7
tube complement.....	1-4	1	6
Mounting details.....	3-1, 3-2	3	6, 7
N			
Notes—			
maintenance.....	6	1
trouble shooting.....	7	2
Notice—safety.....	Front Matter	(Page vii)
O			
Observational checks.....	7	2e
OCT-2, equipment supplied.....	1-1	1	3
OCT-3, equipment supplied.....	1-1	1	3
Operation—			
controls.....	4-1	4
precautions.....	4	1
procedure.....	4-1	4	2
theory of.....	2
Ordering parts.....	Front Matter	(Page vi)
Oscillator—local.....	2	4

SUBJECT	FIGURE OR TABLE	SECTION	PARAGRAPH
P			
Panel controls— see "Controls"			
Parts, ordering of.....	Front Matter	(Page vi)
Pin connections—vacuum-tube.....	5-1	5	3
Power supply— cable.....	3-3, 3-4	3
function of.....	2	13
fuses.....	5	2
source requirements.....	3	3
Practical wiring diagram.....	7-7	7
Precautions to be observed.....	4	1
Pre-operational checks.....	4	3, 4
Preventive maintenance.....	6
Promulgating letter.....	Front Matter	(Page B)
R			
Readying the equipment.....	3	5
Reference data.....	1	8
Requirements— power source.....	3	3
r-f input level.....	1	8
Repair procedures.....	7	4
Repetition of tests—maintenance.....	7	2d
Replacement— fuses.....	5	2
tubes.....	5-1	5	3
Report of failure.....	Front Matter	(Page vi)
Resistance— chart.....	7-5	7
measurements.....	7
Resuscitation notice.....	Front Matter	(Page vii)
RF Monitor— see "Monitor, OCT-2, and OCT-3"	1	8
R-f input level.....	5	1
Routine check chart.....	5-1		
S			
Safety notice.....	Front Matter	(Page vii)
Sample failure report form.....	7-1	7
Schedule—maintenance.....	6-1	6	2
Schematic diagram.....	7-6	7
Servicing— local oscillator.....	7-4	7	5
procedures.....	7	1
Shipping data.....	1-3	1	5
Signal tracing.....	7	4
Sockets—tube, location of.....	5-1	5	3
Source—power, requirements.....	3	3
Spare parts boxes— shipping data.....	1-3, 8-1, 8-2	1, 8
weights and dimensions.....	1-3, 8-1, 8-2	1, 8
Stage localization.....	7	2a
Supplied equipment.....	1-1	1	3
Symptoms of trouble.....	7-2	7	6
System—frequency-shift telegraph.....	2-5	2	15
T			
Table of contents.....	Front Matter	(Page i)
Technical characteristics.....	1	8
Test (s)— bench.....	7-2	7
equipment.....	7-2	7
schedules.....	6-1	6	2
Trouble shooting.....	7	4
Trouble symptoms.....	7-2	7	6

SUBJECT	FIGURE OR TABLE	SECTION	PARAGRAPH
T			
Tubes, electron			
checking of	7	4b
complement	1-4	1	7
pin connections diagram	5-1	5
replacement data	5-1	5	3
Tuning and alignment procedure	7-2	7
U			
Units—major	8-3	8
Unkeyed operation—			
block and schematic diagram	2-3	2
circuit function	2	10
frequency-shift measurement	4-1	4	5, 6
Unpacking the equipment	3	3
V			
Vacuum tube—			
see "Tube"			
Voltage chart	7-5	7
Voltage measurements	7	4d
Voltmeter loading	7	4d
W			
Weights—			
shipping	1-3	1
spare parts boxes	8-1, 8-2	8
Winding data	7-3	7
Wiring diagram	7-7	7
Wrap-arounds for OCT-3	1-1	1	3

