

NAVSHIPS 93237

★

TECHNICAL MANUAL  
*for*  
ADAPTER, CONTROL  
MX-1743A/SRC

+ CHANGE 1 - MX-1743B/SRC

MILWAUKEE ELECTRONICS CORPORATION  
5231A NORTH HOPKINS STREET  
MILWAUKEE 9, WISCONSIN

DEPARTMENT OF THE NAVY  
BUREAU OF SHIPS

UNCLASSIFIED

Contract N126s-86091

Approved by BuShips 21 October, 1958

**LIST OF EFFECTIVE PAGES**

PAGE NUMBERS	CHANGE IN EFFECT	PAGE NUMBERS	CHANGE IN EFFECT
Title Page	Original	4-0 to 4-2	Original
ii to vi	Original	5-1 to 5-2	Original
1-0 to 1-2	Original	6-1	Original
2-1 to 2-2	Original	7-0 to 7-2	Original
3-1	Original		

## INSTRUCTION SHEET

Change 1 to Technical Manual for Adapter, Control MX-1743A/SRC NAVSHIPS 93237.

This change revises the Manual to cover the MX-1743A/SRC and MX-1743B/SRC and is in effect immediately.

This change supersedes temporary correction T-1 only after Field Change 1-MX-1743A/SRC has been accomplished.

1. Insert the corrected wiring diagram Figure 4-3 and corrected schematic diagram Figure 4-4 after Figure 4-2.
2. Insert this permanent change under the front cover.

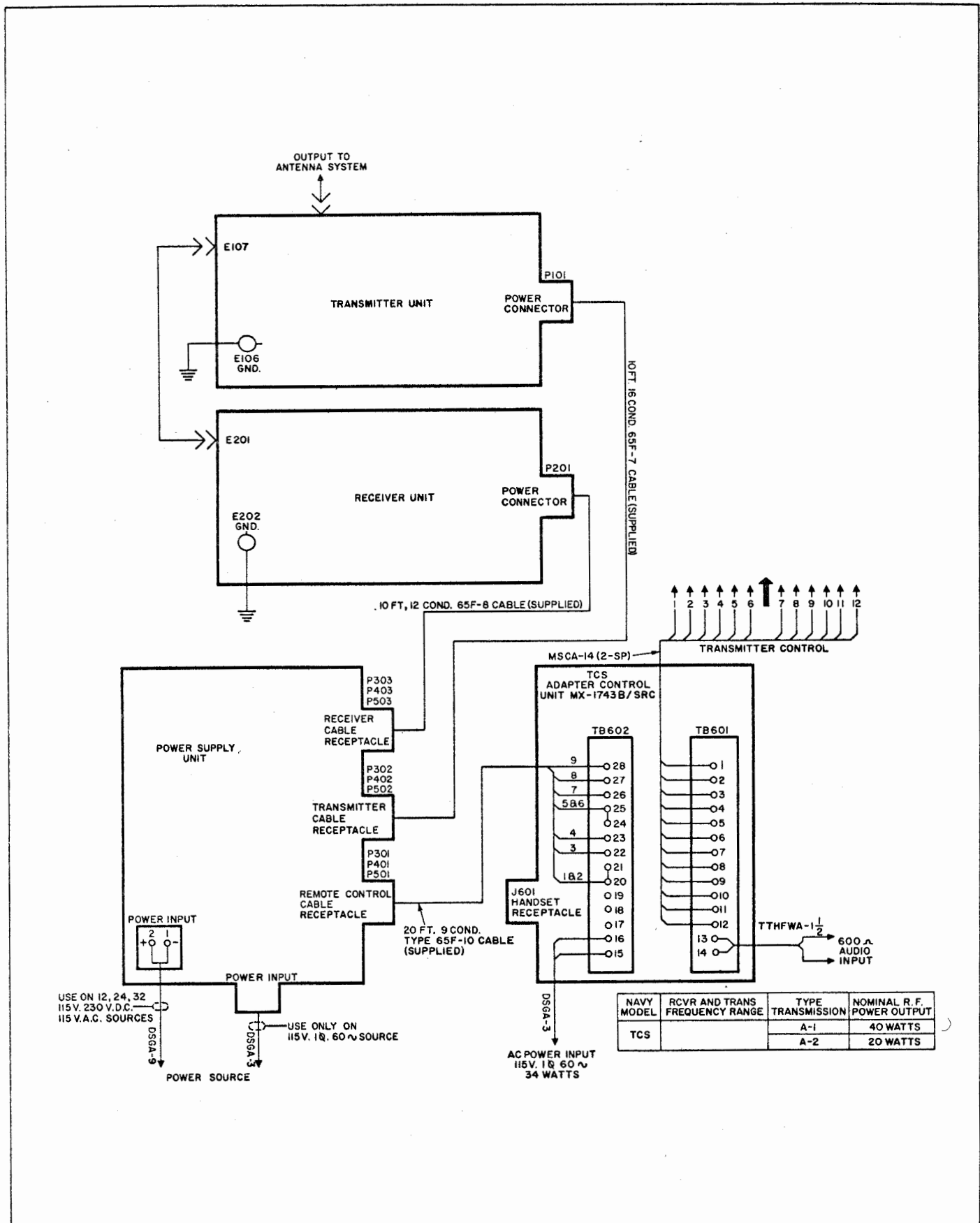

Figure 4-3. Basic Communications System Interconnection Wiring Diagram

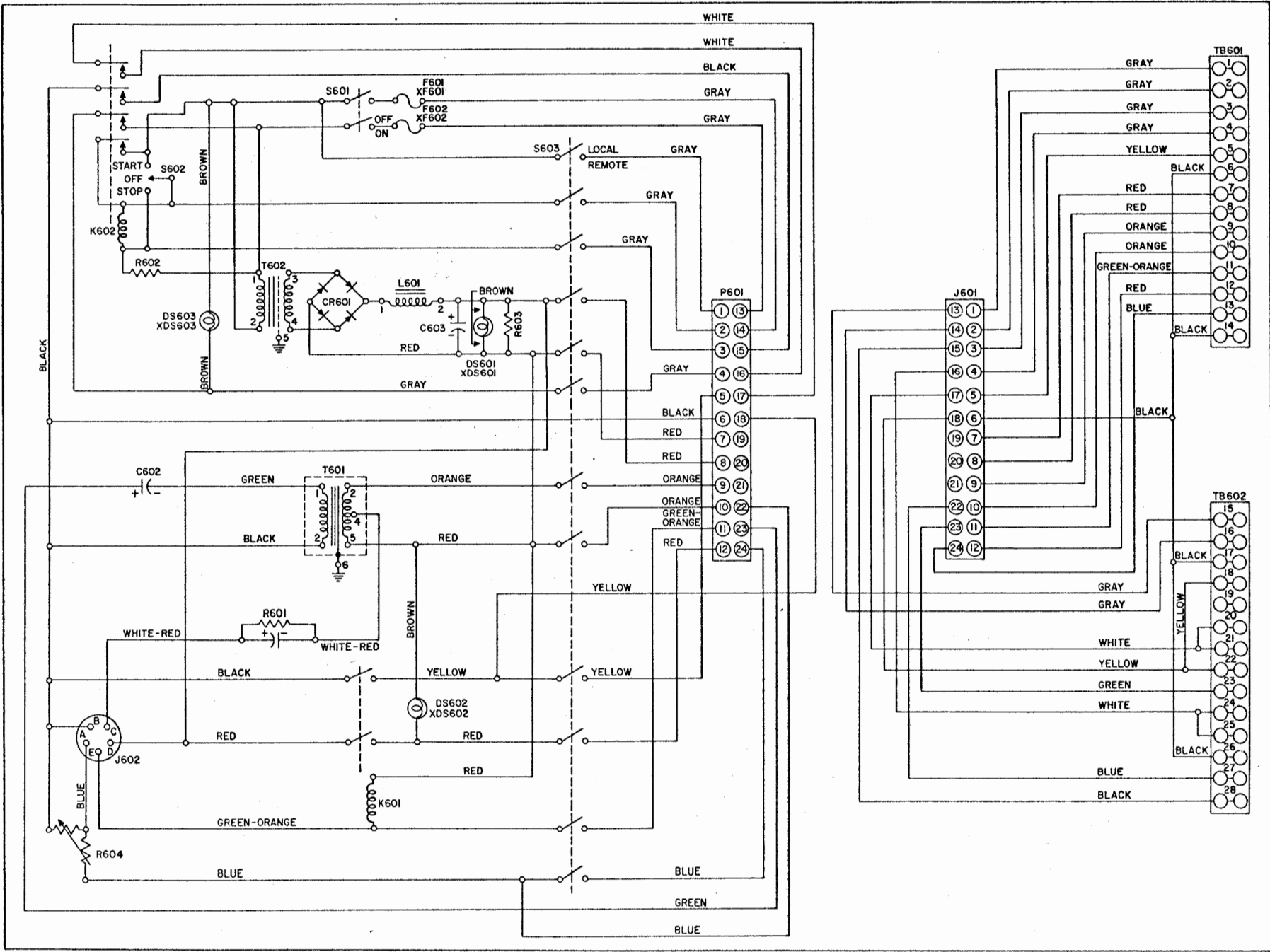

Figure 4-4. Adapter, Control MX-1743B/SRC Schematic Wiring Diagram

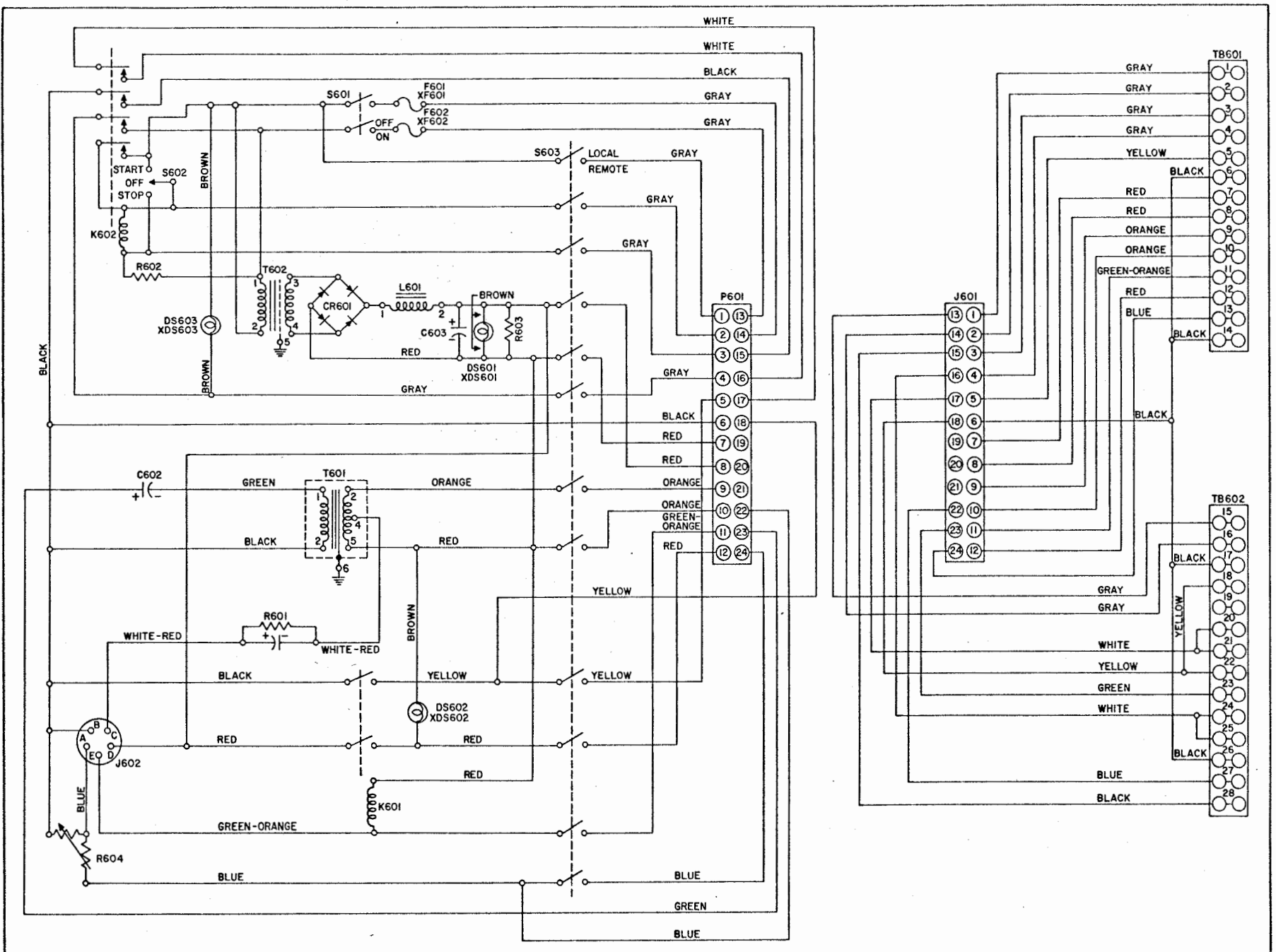

Figure 4-4. Adapter, Control MX-1743B/SRC Schematic Wiring Diagram



**DEPARTMENT OF THE NAVY**  
BUREAU OF SHIPS  
WASHINGTON 25, D. C.

IN REPLY REFER TO  
Code 695E-100

From: Chief, Bureau of Ships  
To: All Activities concerned with the Installation, Operation,  
and Maintenance of the Subject Equipment

Subj: Technical Manual for Control Adapter MX-1743A/SRC,  
NAVSHIPS 93237.

1. This is the Technical Manual for the subject equipment and is in effect upon receipt.
2. When superseded by a later edition, this publication shall be destroyed.
3. Extracts from this publication may be made to facilitate the preparation of other Department of Defense publications.
4. Errors found in this publication (other than obvious typographical errors), which have not been corrected by means of Temporary Corrections or Permanent Changes should be reported. Such report should include the complete title of the publication and the publication number (short title); identify the page and line or figure and location of the error; and be forwarded to the Electronics Publications Section of the Bureau of Ships.
5. All Navy requests for NAVSHIPS electronics publications should be directed to the nearest Bureau of Supplies and Accounts Forms and Publications Supply Point. When changes or revised books are distributed, notice will be included in the Electronics Information Bulletin, NAVSHIPS 900, 022A, and in the Forms and Publications Supply Office Index of Forms and Publications, Cognizance "I".

**A. G. MUMMA**  
Chief of Bureau

**RECORD OF CORRECTIONS MADE**

CHANGE NO.	DATE	FIELD CHANGE NO.	SIGNATURE



**TABLE OF CONTENTS**

SECTION 1--GENERAL INFORMATION		SECTION 4--PRINCIPLES OF OPERATION			
Paragraph	Page	Paragraph	Page		
1-1.	Equipment Illustration . . . . .	1-1	4-1.	Overall Functional Description . . . . .	4-0
1-2.	Functional Description . . . . .	1-1	4-2.	Functional Sections . . . . .	4-0
1-3.	Factory or Field Changes . . . . .	1-1			
1-4.	Quick Reference Data . . . . .	1-1			
1-5.	Equipment Lists . . . . .	1-2			
	<b>SECTION 2--INSTALLATION</b>			<b>SECTION 5--TROUBLE-SHOOTING</b>	
2-1.	Adjustments . . . . .	2-1	5-1.	Test Equipment and Special Tools . . . . .	5-1
2-2.	Installation of Cable . . . . .	2-1	5-2.	Overall Trouble-Shooting. . . . .	5-1
	<b>SECTION 3--OPERATOR'S SECTION</b>			<b>SECTION 6--REPAIR</b>	
3-1.	Functional Operation . . . . .	3-1	6-1.	Failure Report . . . . .	6-1
3-2.	Operating Procedures . . . . .	3-1	6-2.	Tuning and Adjustment . . . . .	6-1
3-3.	Summary of Operating Procedures . . . . .	3-1	6-3.	Removal, Adjustment, Repair and Reassembly of Parts and Subassemblies . . . . .	6-1
				<b>SECTION 7--PARTS LIST</b>	
			7-1.	Introduction . . . . .	7-0

**LIST OF ILLUSTRATIONS**

SECTION 1--GENERAL INFORMATION		SECTION 3--OPERATOR'S SECTION			
Figure	Page	Figure	Page		
1-1.	Adapter, Control MX-1743A/SRC . . . . .	1-0	3-1.	Adapter, Control MX-1743A/SRC . . . . .	3-1
	<b>SECTION 2--INSTALLATION</b>			<b>SECTION 4--PRINCIPLES OF OPERATION</b>	
2-1.	Adapter, Control MX-1743A/SRC-- Removal of Panel-Chassis Assembly . . . . .	2-1	4-1.	Basic Communication System Inter-connection Wiring Diagram . . . . .	4-1
2-2.	Adapter, Control MX-1743A/SRC-- Internal Back Box View, Panel and Chassis Removed . . . . .	2-2	4-2.	Adapter, Control MX-1743A/SRC-- Schematic Wiring Diagram. . . . .	4-2
2-3.	Adapter, Control MX-1743A/SRC-- Mounting Dimensions . . . . .	2-2		<b>SECTION 5--TROUBLE SHOOTING</b>	
2-4.	Installation of TCS Cable 65F-10 . . . . .	2-2	5-1.	Adapter Control--Panel and Chassis Assembly, Top View . . . . .	5-2
			5-2.	Adapter Control--Location of Test Points--Bottom of Chassis. . . . .	5-2

**LIST OF TABLES**

SECTION 1--GENERAL INFORMATION

SECTION 7--PARTS LIST

Table		Page	Table		Page
1-1.	Equipment Supplied . . . . .	1-1	7-1.	Maintenance Parts List . . . . .	7-0
1-2.	Shipping Data . . . . .	1-1	7-2.	List of Manufacturers . . . . .	7-2

SECTION 5--TROUBLE-SHOOTING

5-1.	Adapter, Control MX-1743A/SRC-- System Trouble-Shooting Chart .	5-1
------	--	-----

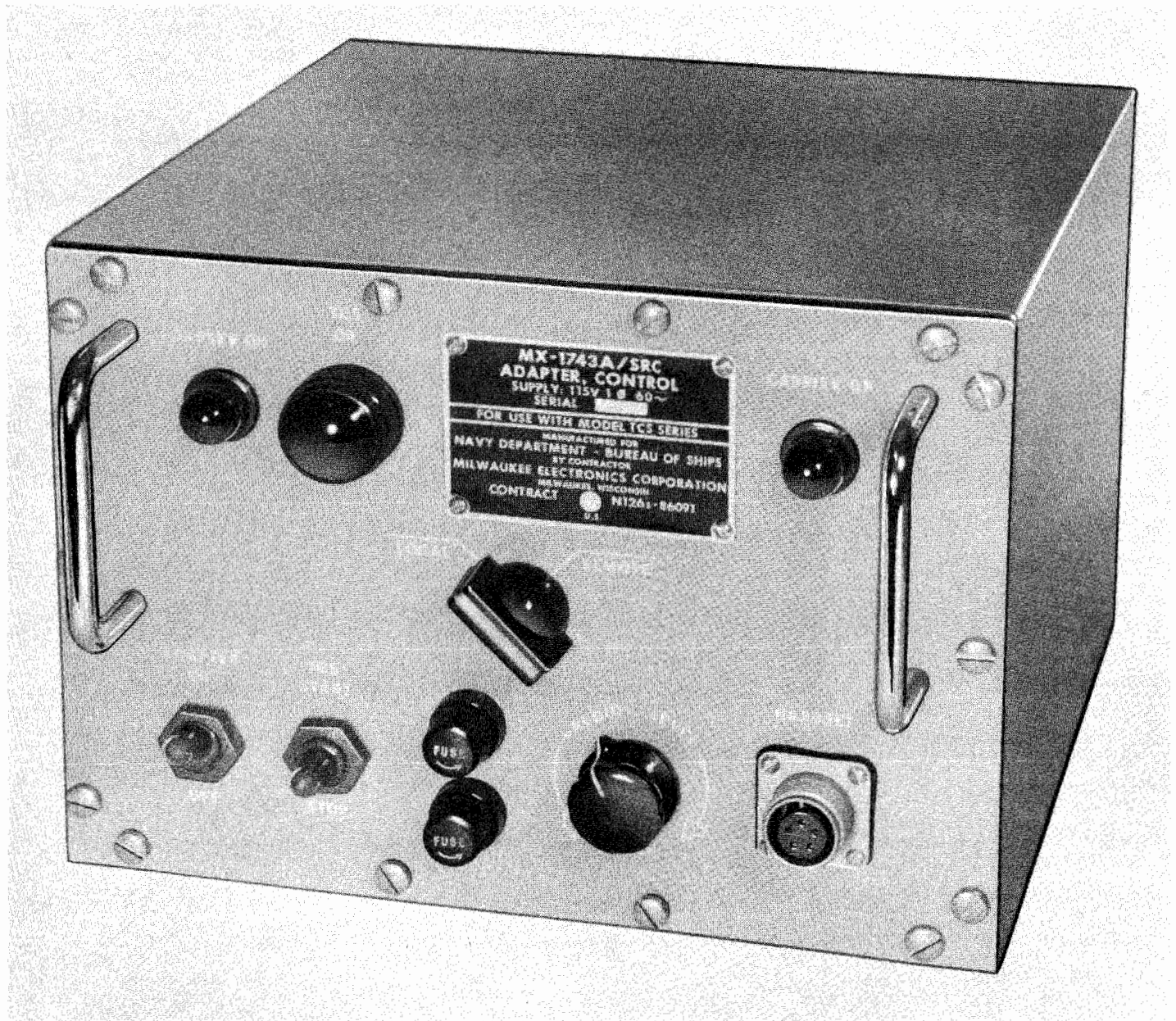

Figure 1-1. Adapter, Control MX-1743A/SRC

## SECTION 1 GENERAL INFORMATION

### 1-1. EQUIPMENT ILLUSTRATION.

This Technical Manual covers the installation, operation, trouble shooting and repair of the Adapter, Control MX-1743A/SRC. Figure 1-1 illustrates the complete unit.

### 1-2. FUNCTIONAL DESCRIPTION.

a. Purpose — The TCS Adapter, Control is designed to allow the interconnection of a TCS Transmitter and Receiver with the standard Navy Six-wire control system. It accomplishes the following operations.

(1) Allows remote or local operation of an associated TCS Transmitter and Receiver.

(2) Turns power on or off for the TCS Transmitter and Receiver.

(3) Provides a visual indication when the carrier is on.

(4) Provides a visual indication when the TCS Transmitter and Receiver is on.

(5) Permits use of a handset for transmission and reception of voice signals by provision of a receptacle on the Adapter Control.

(6) Permits keying of the Transmitter at the Adapter, Control MX-1743A/SRC.

(7) Provides 12 volts D.C. for operation of the microphone and relay power.

b. Description — The Adapter, Control MX-1743A/SRC consists of an enclosure with all the controls on the front panel. Two terminal boards are located inside the unit for external wiring. Knockouts are provided on the back and bottom for installation of stuffing tubes.

### 1-3. FACTORY OR FIELD CHANGES.

No Field Changes have been made.

### 1-4. QUICK REFERENCE DATA.

a. Nomenclature — Adapter, Control MX-1743A/SRC.

b. Contract ESO N126s-86091.

c. Contractor — Milwaukee Electronics Corp., Milwaukee, Wisconsin.

d. Cognizant Naval Inspector — Inspector of Naval Material, Milwaukee, Wisconsin.

e. Frequency — 60 cycles.

f. Power Supply — 115 volts, single phase.

g. There are no vacuum tubes in this equipment.

TABLE 1-1. ADAPTER, CONTROL EQUIPMENT SUPPLIED

Quant. Per Equip.	NOMENCLATURE		OVERALL DIMENSIONS*			Volume	Weight
	Name	Designation	Height	Width	Depth		
1	Adapter-Control	MX-1743A/SRC	7	10-1/2	10	0.425	12-1/4

\*Dimensions are in inches, volume in cubic feet, weight in pounds.

TABLE 1-2. ADAPTER, CONTROL, SHIPPING DATA

Box No.	NOMENCLATURE		OVERALL DIMENSIONS*			Volume	Weight
	Name	Designation	Height	Width	Depth		
1	Adapter, Control Technical Manual	MX-1743A/SRC NavShips	7-1/4	10-3/4	10-1/4	0.46	14-1/4

\*Dimensions are in inches, volume in cubic feet, weight in pounds.

h. Input impedance — 600 ohms in remote position and 35 ohms in local position.

i. Output — Through headphones at J-602 handset receptacle for use with Navy type 51082 handset.

**1-5. EQUIPMENT LISTS.**

a. Equipment Supplied — Table 1-1 lists the equipment supplied under this contract.

b. Equipment Similarities — Later units can be identified, in comparison with earlier units, by the following construction differences:

(1) An indicator lamp has been added to provide TCS start-stop indication.

(2) The position of the "Adapter On" and "Carrier On" indicator lamps have been interchanged.

(3) The position of the "Adapter On" and "TCS start-stop" switches have been interchanged.

(4) "Drawer pull" type handles have been provided for the front panel.

## SECTION 2 INSTALLATION

### 2-1. ADJUSTMENTS.

All adjustments have been made at the factory and no adjustments should be necessary in order to put the equipment into operation. Care should be taken that suitable, watertight connectors are used at the knockout locations. When the chassis is replaced into the back box, care should be taken not to pinch any connecting wires. Receptacle J601 is self-aligning to provide good pressure on its mating plug. The receptacle is designed to be loosely mounted in its bracket.

### 2-2. INSTALLATION OF CABLE.

The MX-1743A/SRC contains terminal strip TB-602 which necessitates the removal of the plug from the TCS Cable No. 65F-10 before the conductors can be connected.

Figure 2-4 indicates the cross connections from terminals 20 through 28 on TB602 to the TCS Cable No. 65F-10.

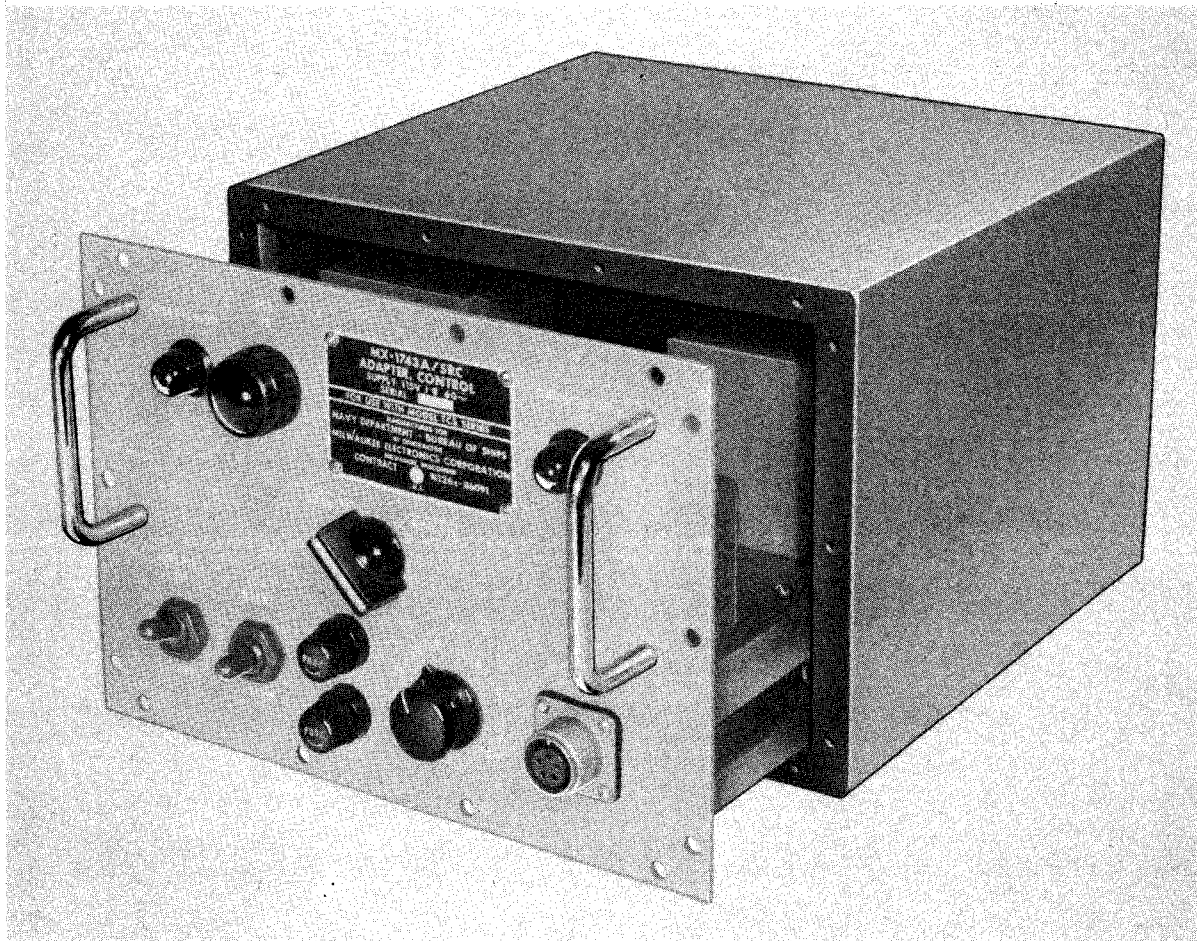

Figure 2-1. Adapter, Control MX-1743A/SRC Removal of Panel-Chassis Assembly



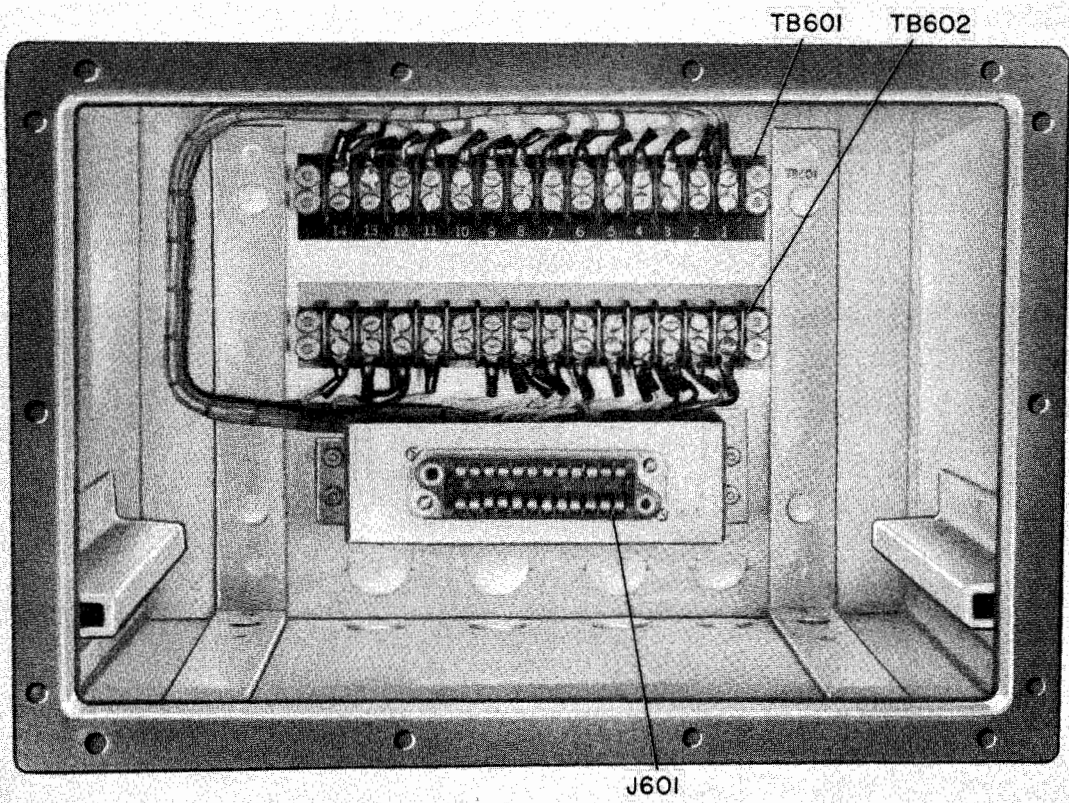

Figure 2-2. Adapter, Control MX-1743A/SRC Internal Back Box View, Panel and Chassis Removed

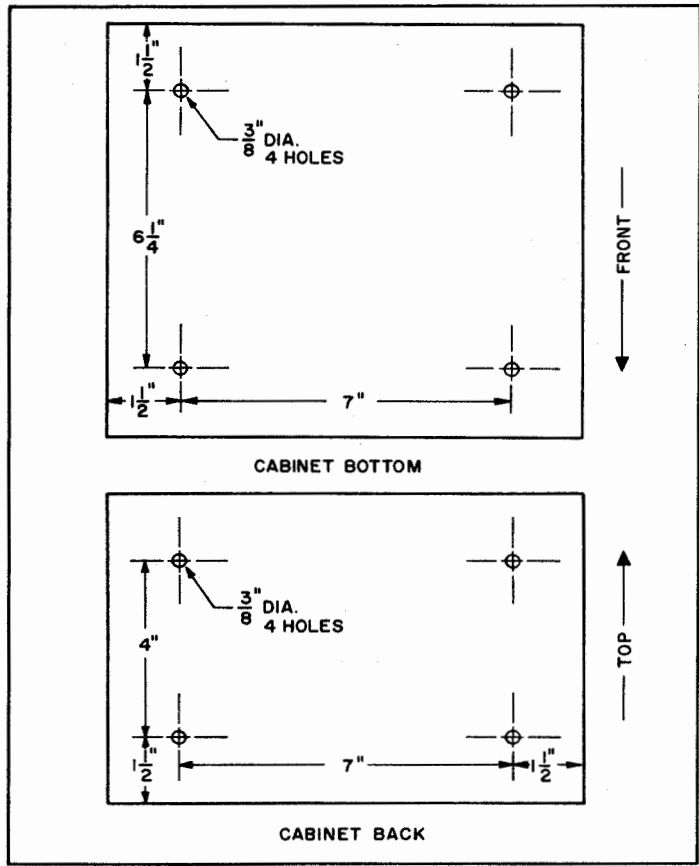

Figure 2-3. Adapter, Control MX-1743A/SRC Mounting Dimensions

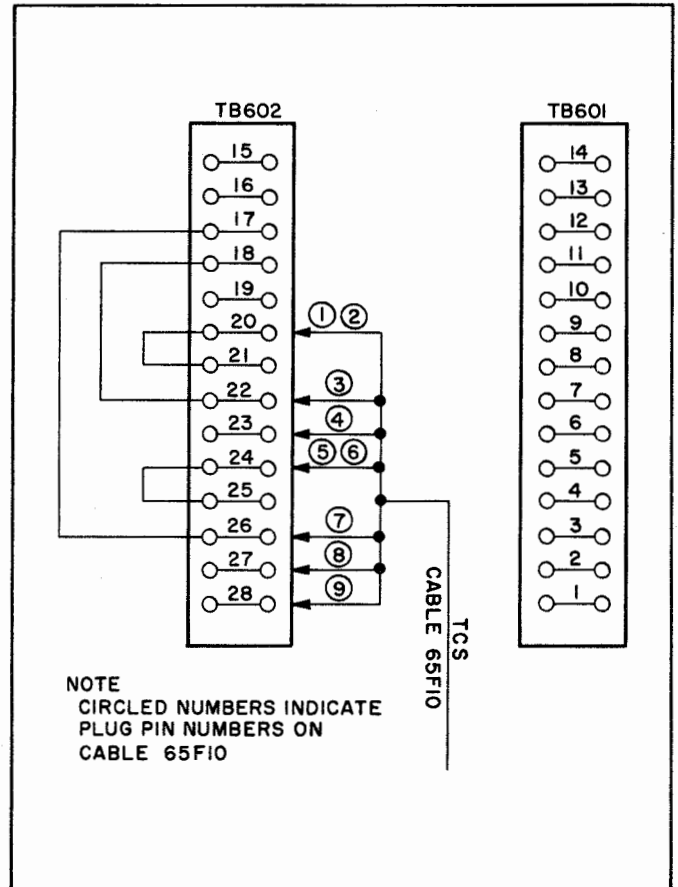

Figure 2-4. Installation of TCS Cable 65F-10

## SECTION 3 OPERATOR'S SECTION

### 3-1. FUNCTIONAL OPERATION.

The TCS Adapter, Control Unit MX-1743A/SRC is used in conjunction with MF/HF Transmitter-Receiver Combination.

### 3-2. OPERATING PROCEDURES.

a. STOP-START CIRCUIT — The start-stop circuit operates on 115 volts A.C. The TCS transmitter may be turned ON or OFF with the Adapter, in either LOCAL or REMOTE position. Relay K602 controls the power circuit of the transmitter.

b. CARRIER CONTROL CIRCUIT — The carrier control circuit utilizes the 13 volts D.C. internal power source. Keying the local or remote hand set allows current to flow through the coil Relay K601. In order for this circuit to operate properly a five-wire hand set should be used in the LOCAL position. The hand set should be connected as follows:

On J602 — the earphone connected from A to B; the microphone connected from C to D; the key connected from E to D.

c. KEYING CIRCUIT — The keying circuit operates in parallel with the TCS transmitter keying circuit.

### 3-3. SUMMARY OF OPERATING PROCEDURES.

- (1) To start the equipment push the Adapter Switch S601 to the ON position. Adapter pilot light should be illuminated.
- (2) Plug hand set #51082 into Receptacle J602.
- (3) Push the TCS Switch to the START position.
- (4) Raise or lower the Audio Level as necessary.
- (5) To secure equipment, both the TCS Switch and the Adapter Switch must be turned to the "OFF" position.

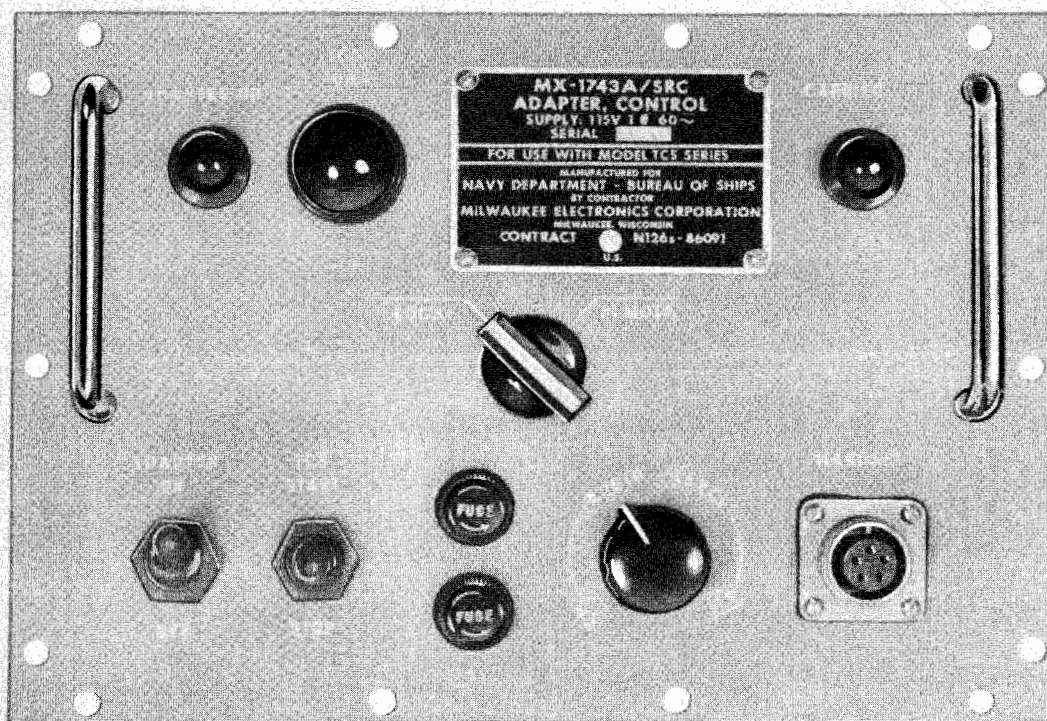

Figure 3-1. Adapter, Control MX-1743A/SRC



## **SECTION 4**

### **PRINCIPLES OF OPERATION**

#### **4-1. OVERALL FUNCTIONAL DESCRIPTION.**

The function of the TCS Adapter Unit is best explained by referring to Figure 4-1, Basic Communication System Interconnection Wiring Plan. The transmitter units, when operated in conjunction with an antenna loading coil, a power supply unit, Navy Type 21770 or Type 21881, and Rectifier Power Unit PP-388/U will function with any standard Navy six-wire control system.

#### **4-2. FUNCTIONAL SECTIONS.**

Essentially the MX-1743A/SRC Adapter, Control is composed of a single phase, full wave, filtered, bridge type rectifier, a D.C. bias to the Input Transformer T601, and various switching arrangements to operate a TCS equipment on a standard ship's supply.

Refer to Figure 3-1. The control is put into operation by closing the Adapter "ON-OFF" Switch S601 whereupon 115 volts A.C. is fed directly from Terminals #13 and #14 on P601 to the Input Transformer T602. This energizes the rectifier circuit and illuminates the Pilot Light DS601. When the TCS Adapter "Start-Stop" Switch S602 is raised Relay K602 closes and locks itself in that position. The spring-loaded switch returns to its neutral position. To open Relay K602, Switch S602 is thrown to the "STOP" position. When the "Local-Remote" Switch S603 is closed, the switch is in the "Remote" position. The TCS Transmitter-Receiver can be operated from other remote positions through the radio transmitter transfer switchboard SB-83/SRT and the radio receiver transfer switch-board SB-82/SRR when the Local-Remote Switch is in the Remote position.

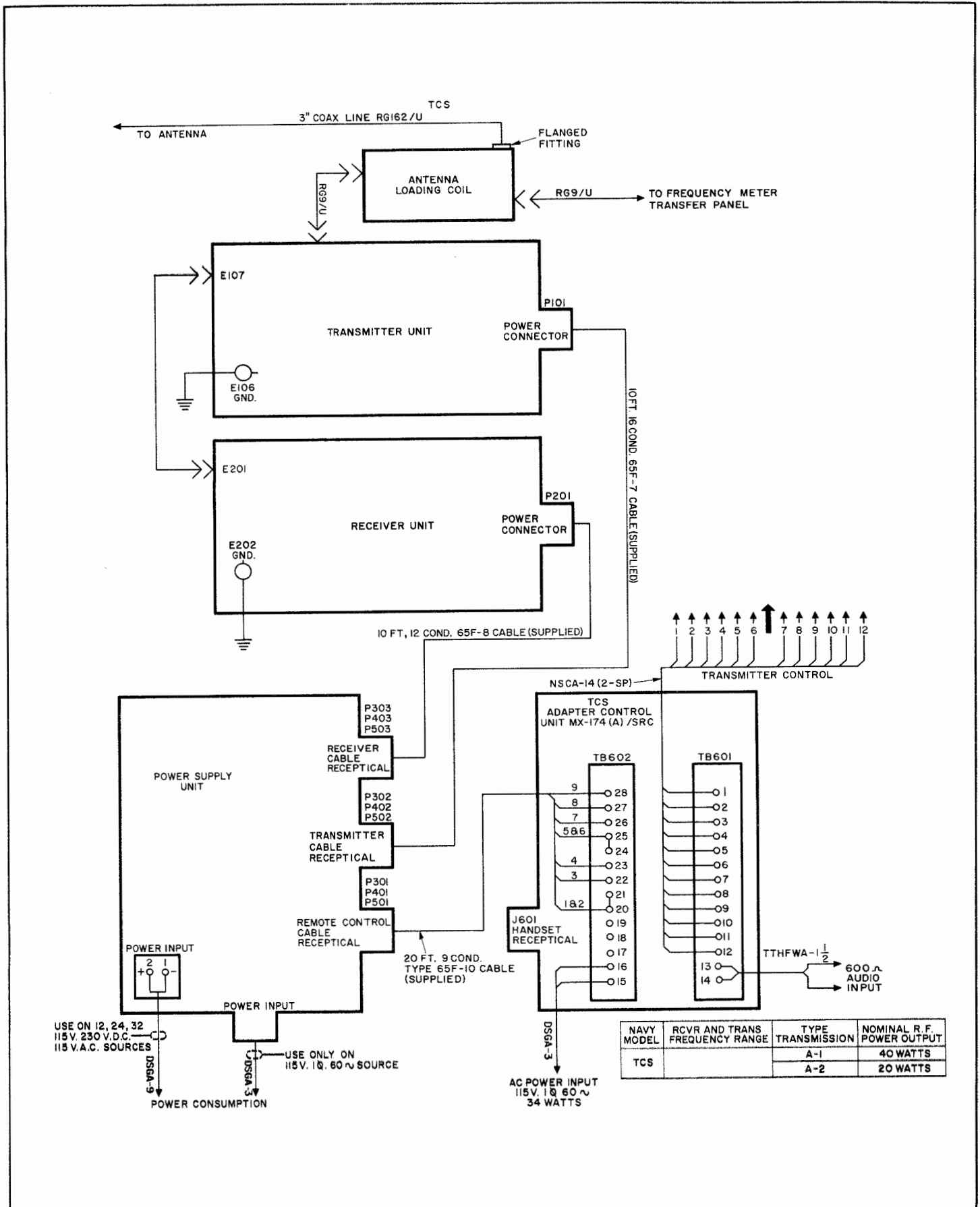

Figure 4-1. Basic Communication System Interconnection Wiring Diagram

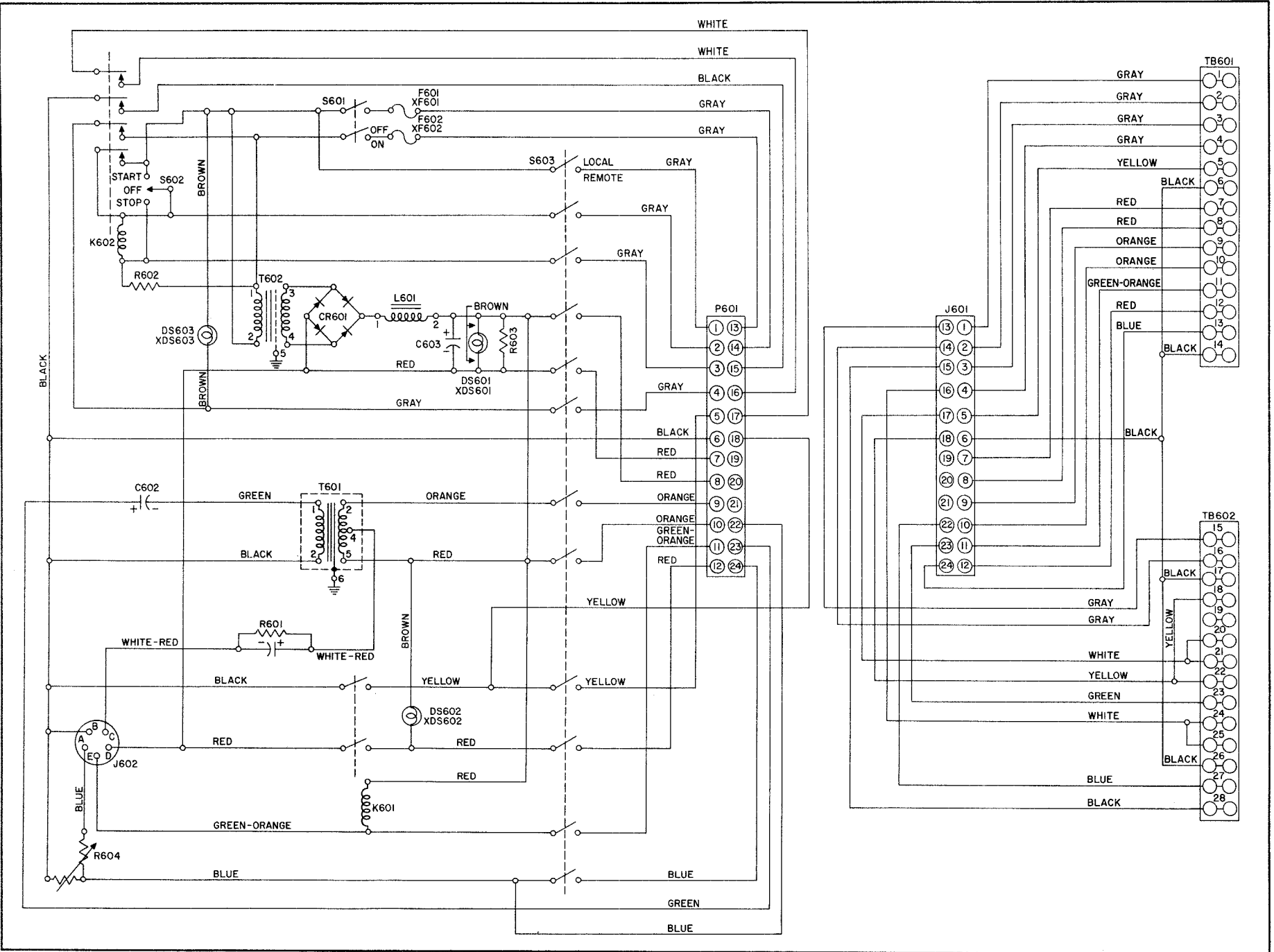

Figure 4-2. Adapter, Control MX-1743A/SRC Schematic Wiring Diagram

## SECTION 5 TROUBLE-SHOOTING

### 5-1. TEST EQUIPMENT AND SPECIAL TOOLS.

The only test equipment necessary is a Volt-Ohm-Ammeter Multitester.

### 5-2. OVERALL TROUBLE-SHOOTING.

a. PRELIMINARY CHECK — Make a careful visual inspection of all items including: S601 Adapter "On-

Off" Switch; S602 TCS Adapter "Start-Stop" Switch; S603 "Local-Remote" Switch; F601 and F602 Fuses; K601 Relay, Pilot Lamps.

b. The above should be carefully checked for charred insulation and any visual physical damage before removing any of the components. Also check for loose cable and broken wires.

TABLE 5-1. ADAPTER, CONTROL MX-1743A/SRC SYSTEM TROUBLE-SHOOTING CHART

STEP	PRELIMINARY ACTION	NORMAL INDICATION	NEXT STEP
1	Chassis removed from panel. Apply 115 volts AC to Terminals #13 and #14 on P601 (Plug). Close Switch S601 (On-off Switch).	"ADAPTER ON" indicator should light.	If pilot light does not light, check Fuses F601-602. Check continuity of Switch S601 (On-Off Switch). Check primary voltage of Power Transformer T602. (Should read 115 volts.) Check secondary voltage of Power Transformer T602. (Should read approximately 13 volts.) Check output voltage of Rectifier Stack CR601. Check voltage across Pilot Lamp DS601.
2	Switch S602 TCS Adapter in "Start" position.	Relay K602 should operate and remain closed when Switch S602 is released. "TCS ON" indicator lamp should be illuminated.	If Relay K602 does not operate, check voltage across relay coil. Check continuity of Switch S602. If lamp DS603 does not light replace pilot lamp.
3	"Local-Remote" Switch S603 in "Local" (open) position: Plug hand set into J602 Receptacle. Operate "Press-to-talk" switch on handset.	Relay K601 will operate illuminating Pilot Lamp DS602.	If Relay K602 does operate and Lamp DS602 does not light replace pilot lamp.

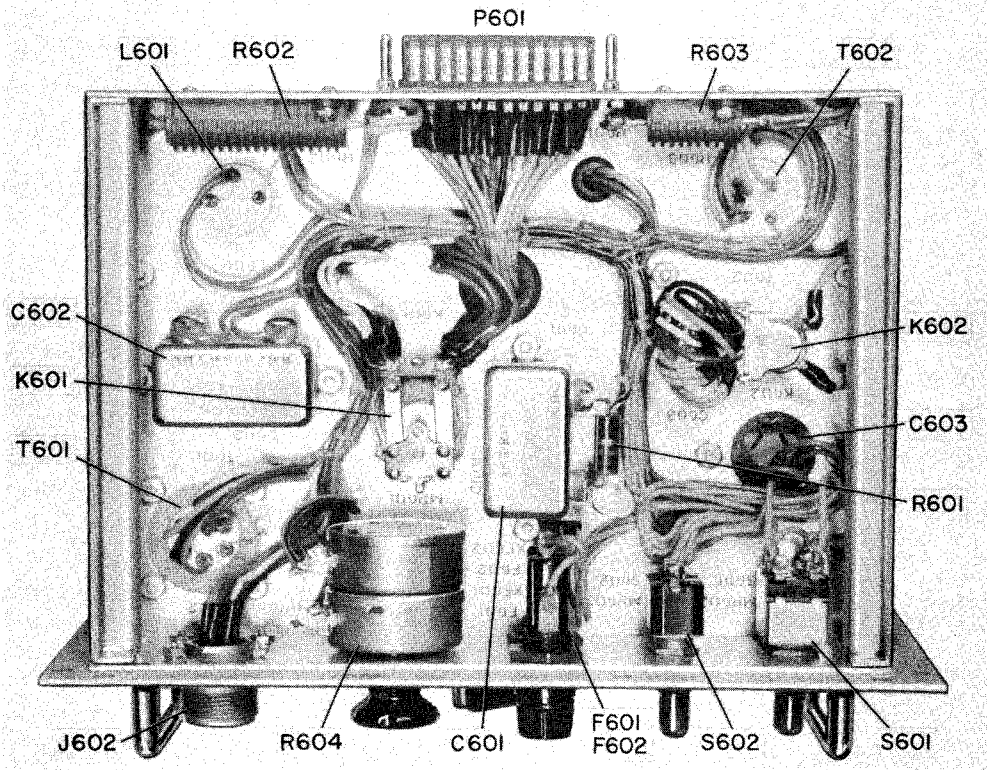

Figure 5-1. Adapter, Control, Panel and Chassis Assembly, Top View

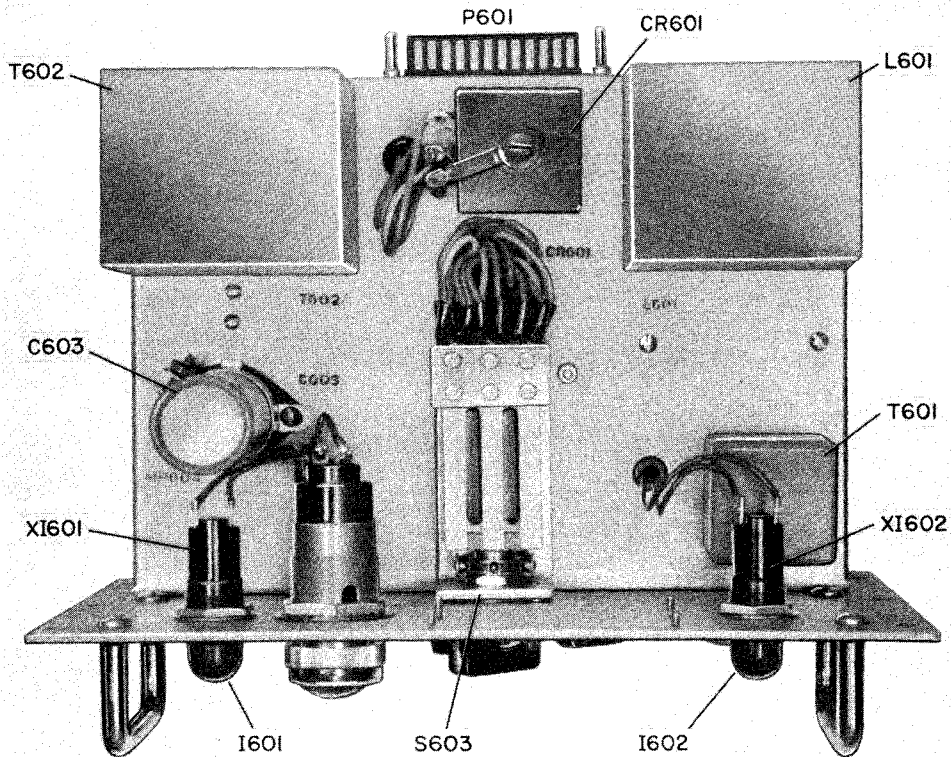

Figure 5-2. Adapter, Control, Location of Test Points, Bottom of Chassis

## SECTION 6 REPAIR

### 6-1. FAILURE REPORT.

#### FAILURE REPORT

Report each failure of the equipment, whether caused by a defective part, wear, improper operation, or an external cause. Use ELECTRONIC FAILURE REPORT form DD787. Each pad of the forms includes full instructions for filling out the forms and forwarding them to the Bureau of Ships. However, the importance of providing complete information cannot be emphasized too much. Be sure that you include the model designation and serial number of the equipment (from the equipment identification plate), the type number and serial of the major unit (from the major unit identification plate), and the type number and reference designation of the particular defective part (from the technical manual). Describe the cause of the failure completely, continuing on the back of the form if necessary. Do not substitute brevity for clarity. And remember--there are two sides to the failure report---

#### YOUR SIDE

Every FAILURE REPORT is a boost for you:

1. It shows that you are doing your job.
2. It helps make your job easier
3. It insures available replacements.
4. It gives you a chance to pass your knowledge to every man on the team.

Always keep a supply of failure report forms on board. You can get them from the nearest Forms and Publications Supply Point.

### 6-2. TUNING AND ADJUSTMENT.

TEST EQUIPMENT AND SPECIAL TOOLS — A Volt-Ohm-Ammeter Multitester is required. In the event that a TCS equipment and a hand set are available, these would be helpful in localizing the troubles.

### 6-3. REMOVAL, ADJUSTMENT, REPAIR AND RE-ASSEMBLY OF PARTS AND SUBASSEMBLIES. (Refer to Figure 2-1.)

Removal of the chassis and panel can be accomplished by removing the fourteen (14) screws from the front panel and slide the panel forward. Tracing the circuit by means of the Schematic Wiring Diagram, Figure 4-2, and pictorial diagrams of the chassis, Figures 5-1 and 5-2, will enable the proper location of the defective component part.

#### BUREAU SIDE

The Bureau of Ships uses the information to:

1. Evaluate present equipment.
2. Improve future equipment.
3. Order replacements for stock.
4. Prepare field changes.
5. Publish maintenance data.

To remove the defective component part it is necessary to unsolder the leads carefully and remove the mounting screws. When the replacement part is replaced to its position make sure that the solder is well fused by exerting a light tension on the lead and check carefully any cracks in the solder. If cracks do appear, resolder the lead.

When the part has been replaced and circuit checks out satisfactory, replace the chassis back into the back box and make sure all the mounting screws in the front panel are tight.

Ratings of all component parts are shown in Section 7. Resistance values of resistors can be checked by means of an Ohmmeter.

## SECTION 7 PARTS LIST

### 7-1. INTRODUCTION.

This section consists of a "Maintenance Parts List," and a "List of Manufacturers." These tables contain information that will enable maintenance and supply activities to fabricate or procure circuit components or parts subject to replacement because of wear.

#### NOTE

New Stock Number Identification Tables (SNIT's) issued by the Electronics Supply Office include Federal Stock Numbers and Source, Maintenance, and Recoverability Codes. Therefore, reference shall be made to the SNIT for this information.

a. To use the Maintenance Parts List (Table 7-1), first identify the part by its reference designation symbol. This information may be obtained from the Description Section or from the wiring schematic or installation diagram. Then locate the symbol in the first column of Table 7-1.

The "Name and Description" column contains the nomenclature of the part, its design characteristics, the manufacturer's prefix code, and the part or drawing number in the order indicated. The "Locating Function" column presents a brief summary of the component's function in the equipment.

b. The List of Manufacturers (Table 7-2) contains a list of the names and addresses of the manufacturers supplying parts used in the equipment and their prefix codes. These codes appear as combinations of capital letters or names near the end of the part description in the Maintenance Parts List, Table 7-1.

TABLE 7-1. ADAPTER, CONTROL MX-1743A/SRC MAINTENANCE PARTS LIST (SHEET 1)

REF. DESIG.	NAME AND DESCRIPTION	LOCATING FUNCTION
C601	CAPACITOR: Bathtub, 100 mfd., 25 VDCW, ASC #ED100-25	Bias
C602	CAPACITOR: Bathtub, 8 mfd., 450 VDCW, ASC #ED-8-450	Input Filter
C603	CAPACITOR: Electrolytic, 1000 mfd., 15 VDCW, MAL #WP-039	Power Supply Filter Capacitor
CR601	RECTIFIER, SELENIUM: Single phase, full wave bridge, RRC #Q1B1S5G	Rectifier
DS601	LAMP, MINIATURE BAYONET: 12 V., GLEC #1813	Pilot Lamps
DS602	Same as DS601	
DS603	LAMP, DOUBLE CONTACT: 125 V., GLEC #6S6DC125	Pilot Lamp
F601	FUSE: 3 amp., BUS #AGC-3	Rectifier Protection
F602	Same as F601	
J601	RECEPTACLE: 24 contact, AMP #26-190-24	Stationary Back Box Receptacle
J602	RECEPTACLE: 5 contact, AMP #MS-3102A-14S-5S	Handset Receptacle
K601	RELAY: 12 VDC coil, DPST-N.O., 2 amp. contacts, ADE #MG2A12VD	Handset Energized Relay
K602	RELAY: 60 VAC coil, contacts 4PST-N.O., 5 amp. contacts, ADE #TF4A60VA	Adapter on Relay

TABLE 7-1. ADAPTER, CONTROL MX-1743A/SRC MAINTENANCE PARTS LIST (SHEET 2)

REF. DESIG.	NAME AND DESCRIPTION	LOCATING FUNCTION
L601	REACTOR: 0.2 Hy., 1 amp., MTC #L-13662	Rectifier Filter Choke
MP601	KNOB, VOLUME CONTROL, BAKELITE: MIC #5001-6	R604 Resistor
MP602	SEAL, TOGGLE SWITCH: APM #1030	Toggle Cover
MP603	Same as MP602	
MP604	PLATE, INSULATING, PHENOLIC: MAL #BP-4	Filter Capacitor Mounting
MP605	GASKET-CABINET, NEOPRENE: MEC #100146	Front Panel
MP606	GASKET-CONNECTOR, NEOPRENE: MEC #100145	Front Panel
P601	PLUG: 24 contact, AMP #26-159-24	Chassis Plug
R601	RESISTOR, FIXED CARBON: 120 ohms, 2 watt, 5% AB #HB	Bias
R602	RESISTOR, FIXED, PRECISION WIRE WOUND: 350 ohms, 50 watt, 3%, DABU #RH-50	K602 Blocking Resistor
R603	RESISTOR, FIXED, PRECISION WIRE WOUND: 150 ohms, 25 watt, 3%, DABU #RH-25	Power Supply Bleeder
R604	RESISTOR, VARIABLE, WIRE WOUND: 600 ohms, dual pad, 4 watts, CPH #H-5695	Handset Receptacle Volume Control
S601	SWITCH, TOGGLE, DPST: Bat handle solder terminals, 250 v., 10 amp., CELI #ST-52K	Power Supply Bleeder
S602	SWITCH, TOGGLE, SPDT-NO: Center off momentary on both sides, CELI #ST-42G	Carrier On Switch
S603	SWITCH, LOCAL-REMOTE, ROTARY: Navy drwg #RE24D173 Rev. G., NEMS	Local-Remote Switch
T601	TRANSFORMER, INPUT, OAS #S-2273	Signal Transformer
T602	TRANSFORMER, POWER: MTC #A1-13428	Rectifier Power
TB601	TERMINAL BOARD: Barrier type, 14 terminal, XLX #14MA14-5B	Back Box Terminal
TB602	Same as TB601	
XDS601	LAMP BASE, MINIATURE BAYONET, GREEN JEWEL: DLC #53410-992	Lamp Holder
XDS602	Same as XDS601	
XDS603	LAMP BASE, DOUBLE CONTACT, BAYONET RED JEWEL: DLC #51202-111	Lamp Holder
XF601	HOLDER, FUSE: BUS #HCM	
XF602	Same as XF601	



TABLE 7-2. ADAPTER, CONTROL MX-1743A/SRC, LIST OF MANUFACTURERS

CODE	MANUFACTURER	ADDRESS
ADE ..	Advance Relays .....	2435 N. Naomi St., Burbank 28, Calif.
AB ..	Allen-Bradley Co. ....	114 W. Greenfield Ave., Milwaukee, Wis.
AMP ..	Amphenol Electronics .....	1830 S. 54th Ave., Chicago 50, Ill.
ACS ..	Astron Corp .....	255 Grant Ave., E. Newark, New Jersey
APM ..	Automatic and Precision Mfg. Co. ....	252 Hawthorne Ave., Yonkers 5, New York
BUS ..	Bussman Manufacturing Co. ....	2534 W. University Ave., St. Louis, Mo.
CELI ..	Carling Electric, Inc .....	495 New Park Ave., Hartford, Conn.
CPH ..	Chicago Telephone Supply .....	1144 W. Beardsley, Elkhart, Indiana
DABU ..	Dale Products, Inc .....	P.O. Box 136, Columbus, Nebraska
DLC ..	Dialight Corp .....	60 Stewart Ave., Brooklyn 37, New York
XLX ..	Excellex Electronics, Inc .....	335 Van Siclen Ave., Brooklyn 7, New York
GLEC ..	General Electric Co .....	Nela Park, Cleveland 12, Ohio
MAL ..	P. R. Mallory and Co., Inc .....	3029 E. Washington St., Indianapolis, Ind.
MEC ..	Milwaukee Electronics Corp .....	5231-A N. Hopkins St., Milwaukee 9, Wis.
MTC ..	Milwaukee Transformer Co .....	5231 N. Hopkins St., Milwaukee 9, Wis.
MIC ..	Molded Insulation Co .....	335 E. Price St., Philadelphia 44, Pa.
NEMS ..	Nems-Clarke, Inc .....	919 Jessup-Blair Drive, Silver Springs, Md.
RRC ..	Radio Receptor Co., Inc .....	240 Wythe Ave., Brooklyn 11, New York
OAS ..	Oscar A. Schott Co .....	500 - 11th Ave., South, Minneapolis 4, Minn.