

NAVSHIPS 93084



TECHNICAL MANUAL

for

ADAPTER, CONTROL
MX-1743/SRC

JOHN R. HOLLINGSWORTH
NUTT & FRENCH CREEK ROADS
PHOENIXVILLE, PENNA.

DEPARTMENT OF THE NAVY
BUREAU OF SHIPS

UNCLASSIFIED

Contract: N126s-81281

Approved by BuShips: 18 November 1957

LIST OF EFFECTIVE PAGES

PAGE NUMBERS	CHANGE IN EFFECT	PAGE NUMBERS	CHANGE IN EFFECT
Title Page	Original	4-0 to 4-4	Original
ii to vi	Original	5-1 to 5-2	Original
1-0 to 1-1	Original	6-1	Original
2-0 to 2-2	Original	7-0 to 7-5	Original
3-1	Original		



DEPARTMENT OF THE NAVY
BUREAU OF SHIPS
WASHINGTON 25, D. C.

IN REPLY REFER TO
Code 993-100

From: Chief, Bureau of Ships
To: All Activities concerned with the Installation,
Operation, and Maintenance of the Subject Equipment
Subj: Technical Manual for Adapter, Control MX-1743/SRC,
NAVSHIPS 93084

1. This non-registered publication is the technical manual for the subject equipment and is in effect upon receipt.
2. When superseded by a later edition, this publication shall be destroyed.
3. Extracts from this publication may be made to facilitate the preparation of other Department of Defense publications.
4. Errors found in this publication (other than obvious typographical errors), which have not been corrected by means of Temporary Corrections or Permanent Changes, should be reported. Such report should include the complete title of the publication and the publication number (short title); identify the page and line or figure and location of the error; describe the error or indicate what change should be made; and be forwarded to the Electronics Publications Section of the Bureau of Ships.
5. All Navy requests for NAVSHIPS electronics publications should be directed to the nearest Bureau of Supplies and Accounts Forms and Publications Supply Point. When changes or revised books are distributed, notice will be included in the Electronics Information Bulletin, NAVSHIPS 900,022, and in the Index of Bureau of Ships General and Electronics Publications, NAVSHIPS 250-020.

A. G. MUMMA
Chief of Bureau

TABLE OF CONTENTS**SECTION 1—GENERAL INFORMATION**

<i>Paragraph</i>	<i>Page</i>
1-1. Equipment Description	1-1
1-2. Function Description	1-1
1-3. Factory or Field Changes	1-1
1-4. Quick Reference Data	1-1
1-5. Equipment Lists	1-1

SECTION 2—INSTALLATION

2-1. Adjustments	2-0
2-2. Installation of Cable	2-2

SECTION 3—OPERATOR'S SECTION

3-1. Functional Operation	3-1
3-2. Operating Procedures	3-1
3-3. Summary of Operating Procedures	3-1

SECTION 4—PRINCIPLES OF OPERATION

4-1. Overall Functional Description	4-0
4-2. Functional Sections	4-0

SECTION 5—TROUBLE-SHOOTING

<i>Paragraph</i>	<i>Page</i>
5-1. Test Equipment and Special Tools	5-1
5-2. Overall Trouble-Shooting	5-1

SECTION 6—REPAIR

6-1. Failure Report	6-1
6-2. Tuning and Adjustment	6-1
6-3. Removal, Adjustment, Repair and Reassembly of Parts and Sub-Assemblies	6-1

SECTION 7—PARTS LIST

7-1. Introduction	7-0
7-2. Maintenance Parts List	7-0
7-3. Stock Number Identification	7-0
7-4. List of Manufacturers	7-0
7-5. Notes	7-0
a. Source Codes	7-0
b. Maintenance Codes	7-1
c. Recoverability Codes	7-1

LIST OF ILLUSTRATIONS**SECTION 1—GENERAL INFORMATION**

<i>Figure</i>	<i>Page</i>
1-1. Adapter, Control MX-1743/SRC	1-0

SECTION 2—INSTALLATION

2-1. Adapter, Control MX-1743/SRC — Removal of Panel-Chassis Assembly	2-0
2-2. Adapter, Control MX-1743/SRC — View Showing Internal of Back Box	2-1
2-3. Adapter, Control MX-1743/SRC—Mounting Dimensions	2-1
2-4. Installation of TCS Cable 65F-10.....	2-2

SECTION 3—OPERATOR'S SECTION

3-1. Adapter, Control MX-1743/SRC	3-1
---	-----

SECTION 4—PRINCIPLES OF OPERATION

<i>Figure</i>	<i>Page</i>
4-1. Basic Communication System Interconnection Wiring Plan	4-1
4-2. Schematic Wiring Diagram	4-3

SECTION 5—TROUBLE-SHOOTING

5-1. Adapter Control—Panel Chassis Assembly, Top View	5-2
5-2. Adapter, Control—Location of Test Points —Bottom of Chassis	5-2

LIST OF TABLES

SECTION 1—GENERAL INFORMATION		SECTION 7—PARTS LIST	
<i>Table</i>	<i>Page</i>	<i>Table</i>	<i>Page</i>
1-1. Equipment Supplied	1-1	7-1. Maintenance Parts List	7-2
1-2. Shipping Data	1-1	7-2. Stock Number Identification Table	7-4
SECTION 5—TROUBLE-SHOOTING		7-3. List of Manufacturers	7-5
5-1. Adapter, Control MX-1743/SRC—System Trouble-Shooting Chart	5-1		

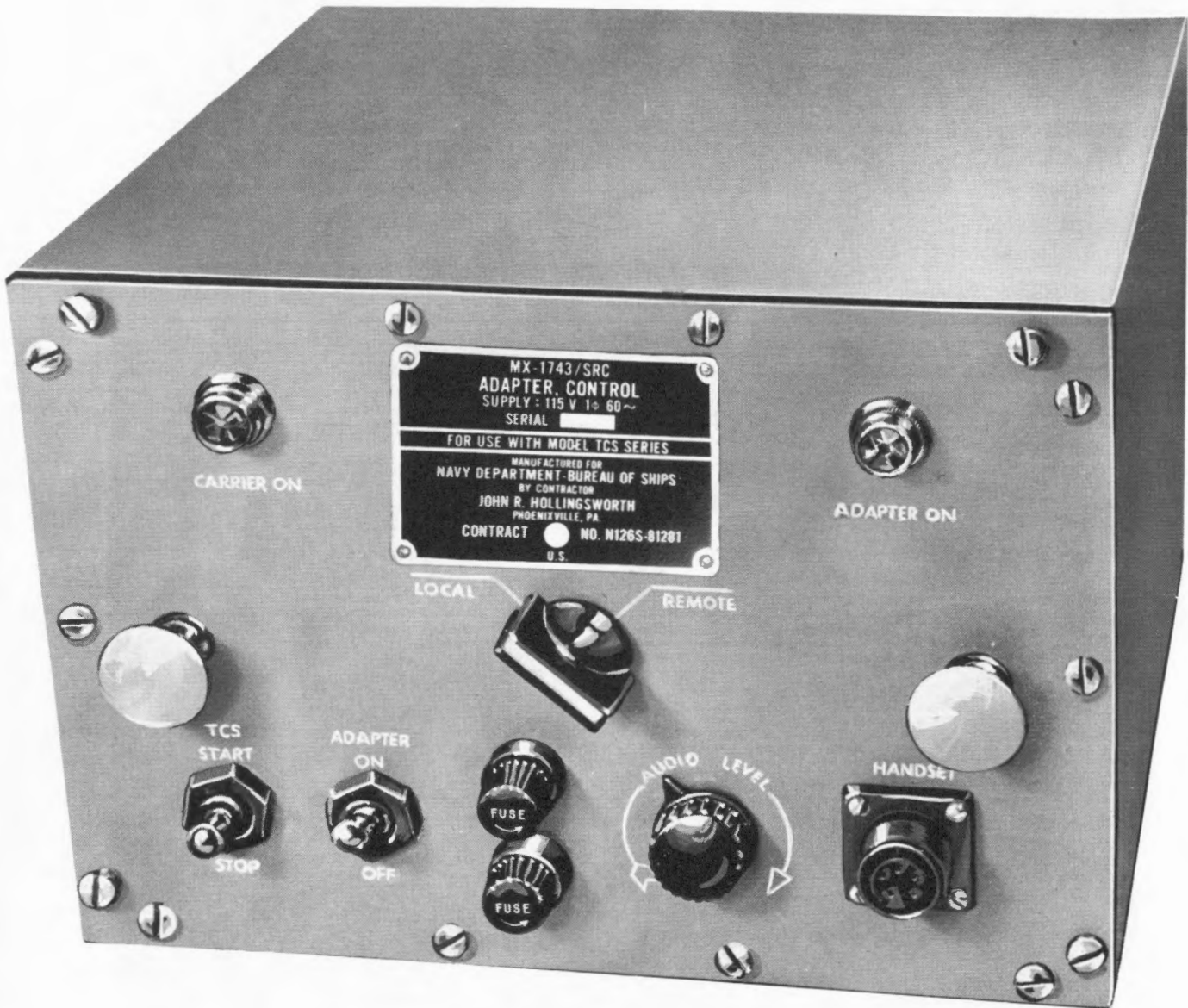

Figure 1-1. Adapter, Control MX-1743/SRC

SECTION 1 GENERAL INFORMATION

1-1. EQUIPMENT DESCRIPTION.

This manual covers the installation and operation of the TCS Adapter, Control Unit, MX-1743/SRC, as illustrated.

1-2. FUNCTIONAL DESCRIPTION.

The TCS Adapter Unit is designed to allow interconnection of a TCS Transceiver with the standard Navy six-wire control system. The Navy MX-1743/SRC Adapter, Control Unit operates on 115 volts A.C. and it provides 12 volt D.C. for microphone and relay power.

1-3. FACTORY OR FIELD CHANGES.

No field changes have been made.

1-4. QUICK REFERENCE DATA.

- a. Frequency—60 cycles.
- b. Power Supply—115 volts, single phase.
- c. There are no vacuum tubes in this equipment.
- d. Input Impedance—600 ohms in remote position and 35 ohms in local position.
- e. Output—through head phones at #J-602 hand set receptacle. For use with Type #51082 hand set.
- f. Navy Adapter, Control Unit MX-1743/SRC.

1-5. EQUIPMENT LISTS.

TABLE 1-1. ADAPTER, CONTROL, EQUIPMENT SUPPLIED

QUANT. PER EQUIP.	NOMENCLATURE		OVERALL DIMENSIONS *			VOLUME	WEIGHT
	NAME	DESIGNATION	HEIGHT	WIDTH	DEPTH		
1	Adapter, Control	MX-1743/SRC	7	10½	10	1.1	12¼

* Dimensions are in inches, volume in cubic feet, weight in pounds.

TABLE 1-2. ADAPTER, CONTROL, SHIPPING DATA

BOX NO.	NOMENCLATURE		OVERALL DIMENSIONS *			VOLUME	WEIGHT
	NAME	DESIGNATION	HEIGHT	WIDTH	DEPTH		
1	Adapter, Control Technical Manual	MX-1743/SRC Navships 93084	7¼	10¾	10¼	1.1	14¼

* Dimensions are in inches, volume in cubic feet, weight in pounds.

SECTION 2 INSTALLATION

2-1. ADJUSTMENTS.

All adjustments have been made at the factory and no adjustments should be necessary in order to put the equipment into operation. Care should be taken that suitable, watertight connectors are used at the knock-

out locations. When the chassis is replaced into the back box, care should be taken not to pinch any connecting wires. Receptacle #J-601 is self-aligning to provide good pressure on its mating plug. The receptacle is designed to be loosely mounted in its bracket.

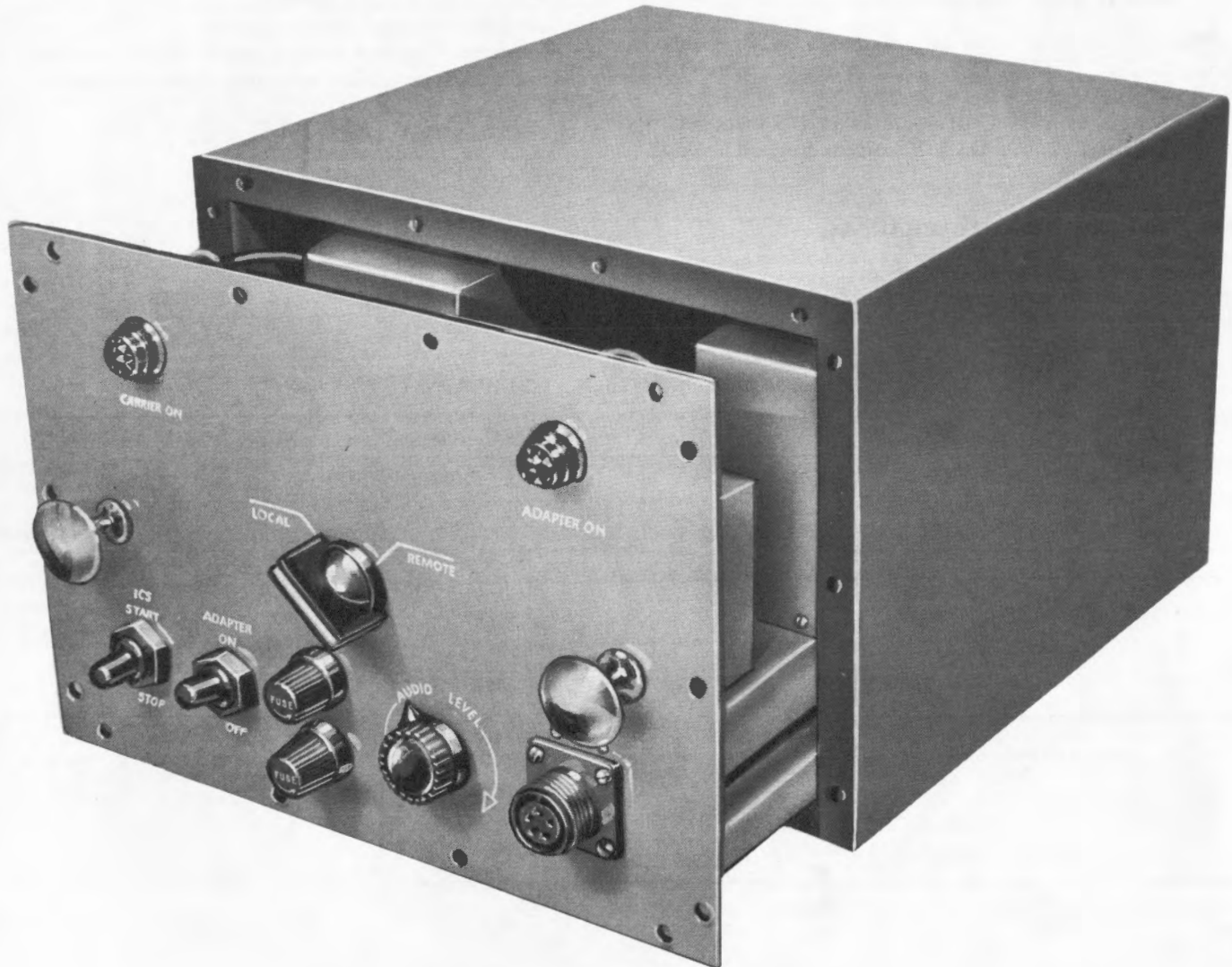

Figure 2-1. Adapter, Control MX-1743/SRC, Removal of Panel-Chassis Assembly

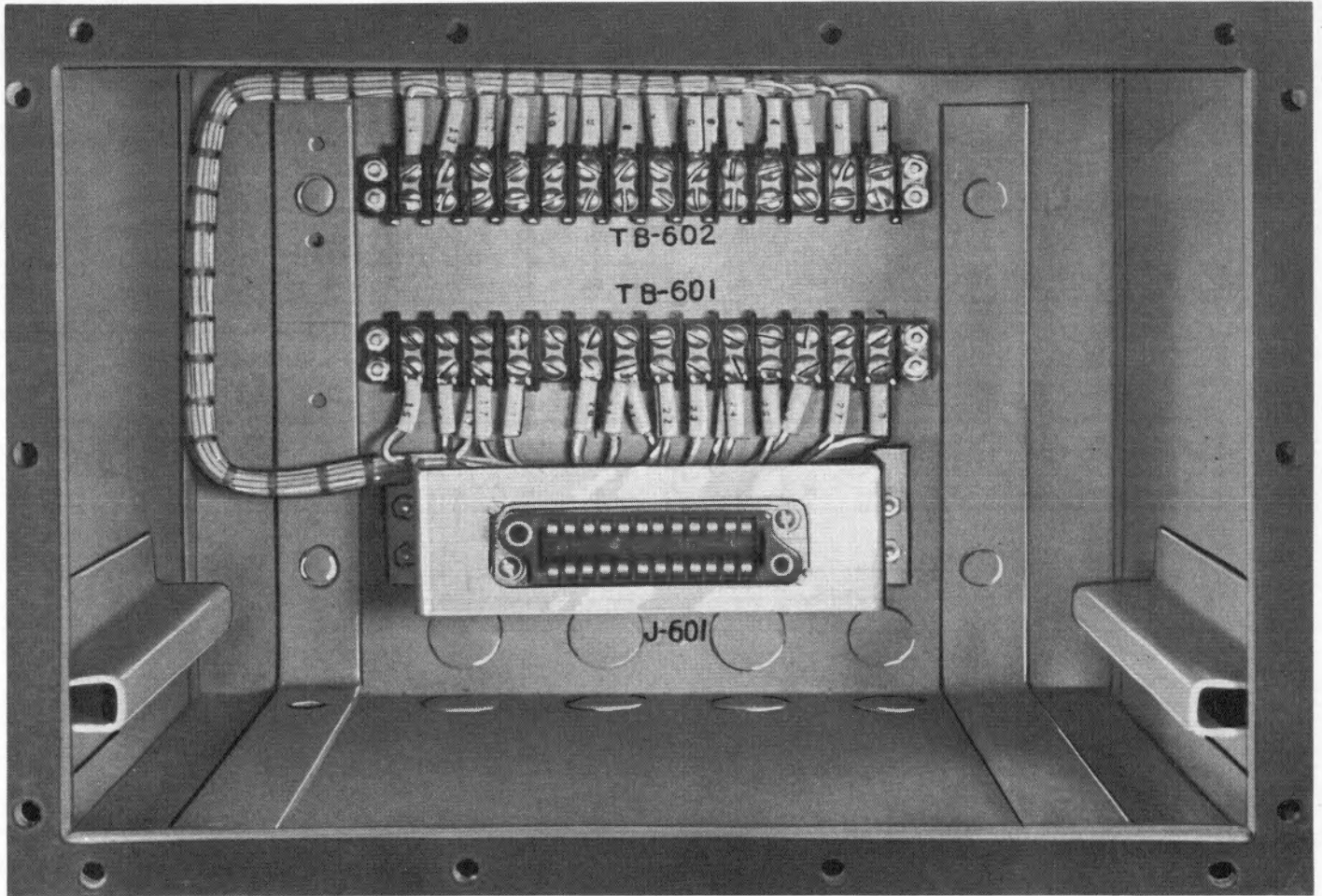

Figure 2-2. Adapter, Control MX-1743/SRC, Internal Back Box View, Panel and Chassis Removed

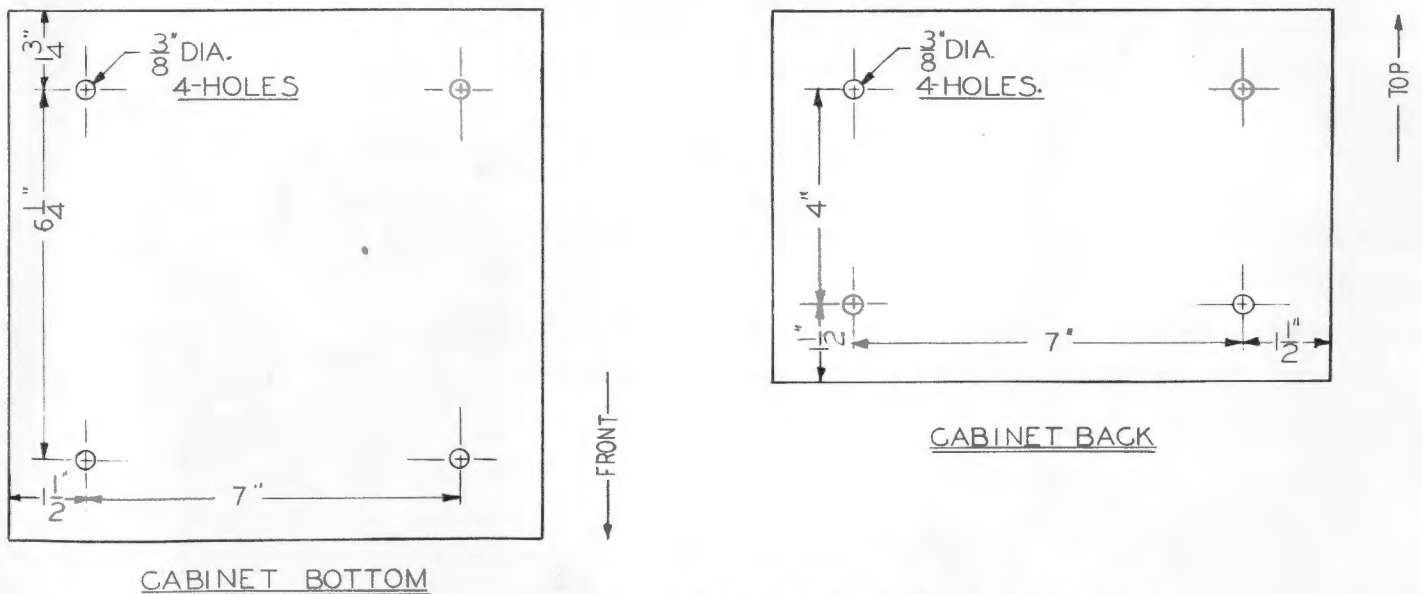

Figure 2-3. Adapter, Control MX-1743/SRC, Mounting Dimensions

2-2. INSTALLATION OF CABLE.

The MX-1743/SRC contains terminal strip TB-602 which necessitates the removal of the plug from the TCS Cable No. 65F-10 before the conductors can be connected.

Figure 2-4 indicates the cross connections from terminals 20 through 28 on TB-602 to the TCS Cable No. 65F-10.

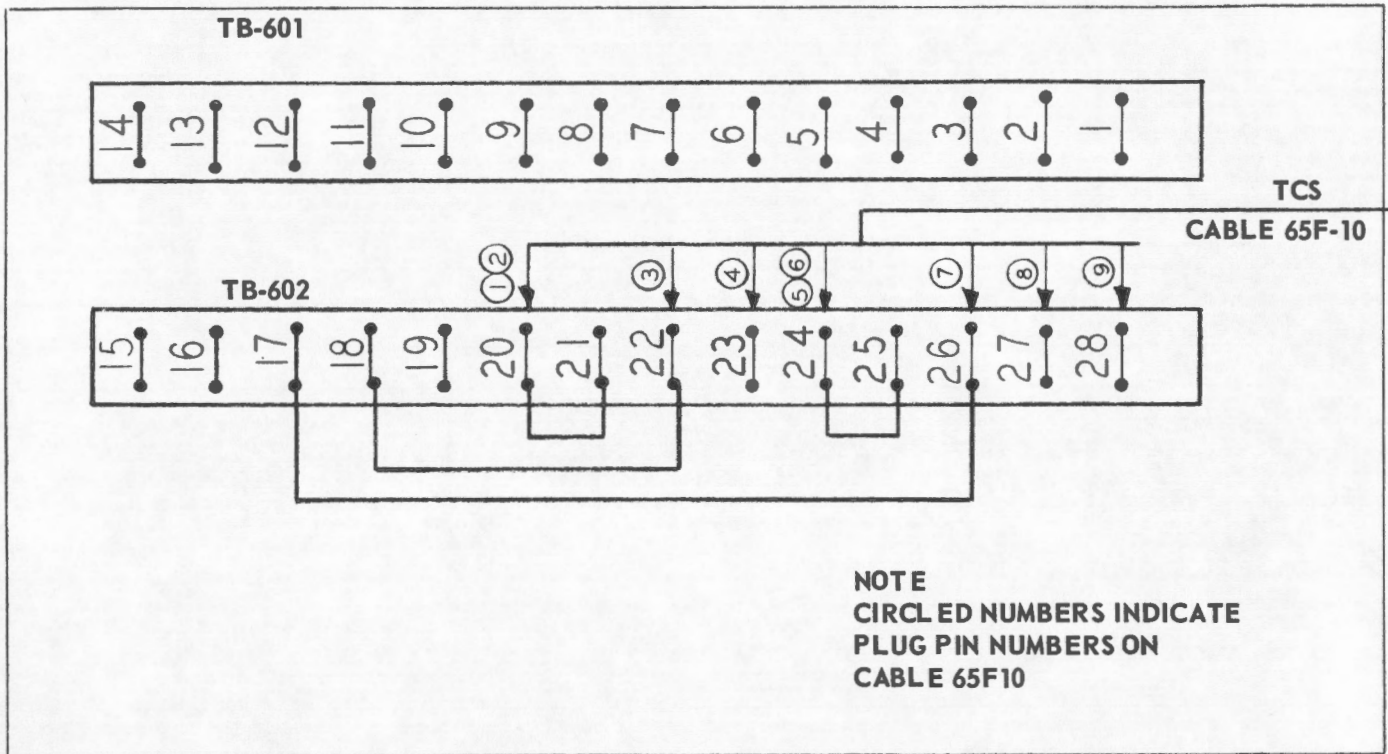

Figure 2-4. Installation of TCS Cable 65 F-10

SECTION 3 OPERATOR'S SECTION

3-1. FUNCTIONAL OPERATION.

The TCS Adapter, Control Unit MX-1743/SRC is used in conjunction with MF/HF Transmitter-Receiver Combination.

3-2. OPERATING PROCEDURES.

a. STOP-START CIRCUIT.—The start-stop circuit operates on 115 volts A.C. The TCS transmitter may be turned ON or OFF with the Adapter, in either LOCAL or REMOTE position. Relay #K-602 controls the power circuit of the transmitter.

b. CARRIER CONTROL CIRCUIT.—The carrier control circuit utilizes the 13 volts D.C. internal power source. Keying the local or remote hand set allows current to flow through the coil Relay #K-601. In order for this circuit to operate properly a five-wire hand set should be used in the LOCAL position. The hand set should be connected as follows:

On J-601—the receiver connected from A to B; the microphone connected from C to D; the key connected from E to D.

c. KEYING CIRCUIT.—The keying circuit operates in parallel with the TCS transmitter keying circuit.

3-3. SUMMARY OF OPERATING PROCEDURES.

- (1) To start the equipment turn the Adapter Switch (S-601) to the ON position. Adapter pilot light should be illuminated.
- (2) Plug hand set #51082 into Receptacle J-602.
- (3) Turn the TCS Switch to the START position.
- (4) Raise or lower the Audio Level as necessary.
- (5) To secure equipment, both the TCS Switch and the Adapter Switch must be turned to the "OFF" position.

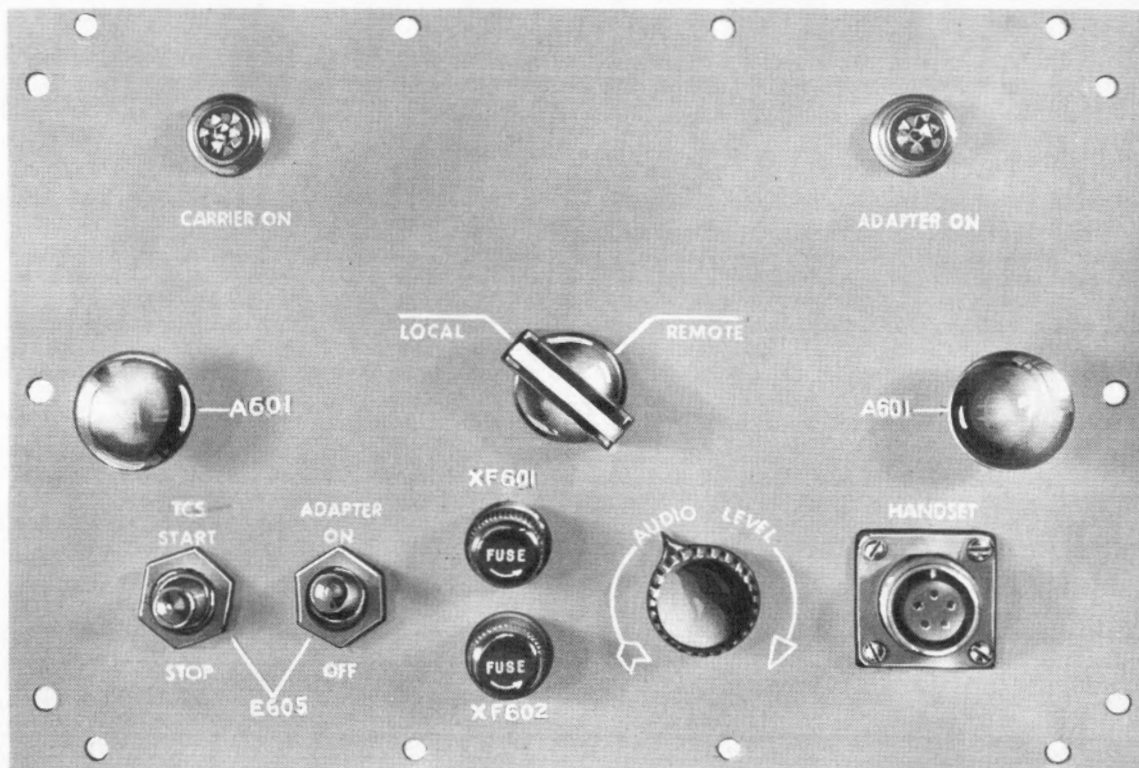

Figure 3-1. Adapter, Control MX-1743/SRC

SECTION 4

PRINCIPLES OF OPERATION

4-1. OVERALL FUNCTIONAL DESCRIPTION.

The function of the TCS Adapter Unit is best explained by referring to Figure 4-1, Basic Communication System Interconnection Wiring Plan. The transceiver units, when operated in conjunction with an antenna loading coil, a power supply unit, Navy Type 21770 or Type 21881, and Rectifier Power Unit PP-388/U will function with any standard Navy six-wire control system.

4-2. FUNCTIONAL SECTIONS.

Essentially the MX-1743/SRC Adapter, Control is composed of a single phase, full wave, filtered, bridge type rectifier, a D.C. bias to the Input Transformer T-601, and various switching arrangements to operate a TCS equipment on a standard ship's supply.

Refer to Figure 3-1. The control is put into opera-

tion by closing the Adapter "ON-OFF" Switch (S-601) whereupon 115 volts A.C. is fed directly from Terminals #13 and #14 on P-601 to the Input Transformer (T-602). This energizes the rectifier circuit and illuminates the Pilot Light (I-601). When the TCS Adapter "Start-Stop" Switch (S-602) is raised Relay (K-602) closes and locks itself in that position. The spring-loaded switch returns to its neutral position. To open Relay (K-602), Switch (S-602) is thrown to the "STOP" position. When the "Local-Remote" Switch (S-603) is closed, the switch is in the "Remote" position. The TCS Transmitter-Receiver can be operated from other remote positions through the radio transmitter transfer switchboard SB-83/SRT and the radio receiver transfer switchboard SB-82/SRR when the Local-Remote Switch is in the Remote position.

FIGURE 1

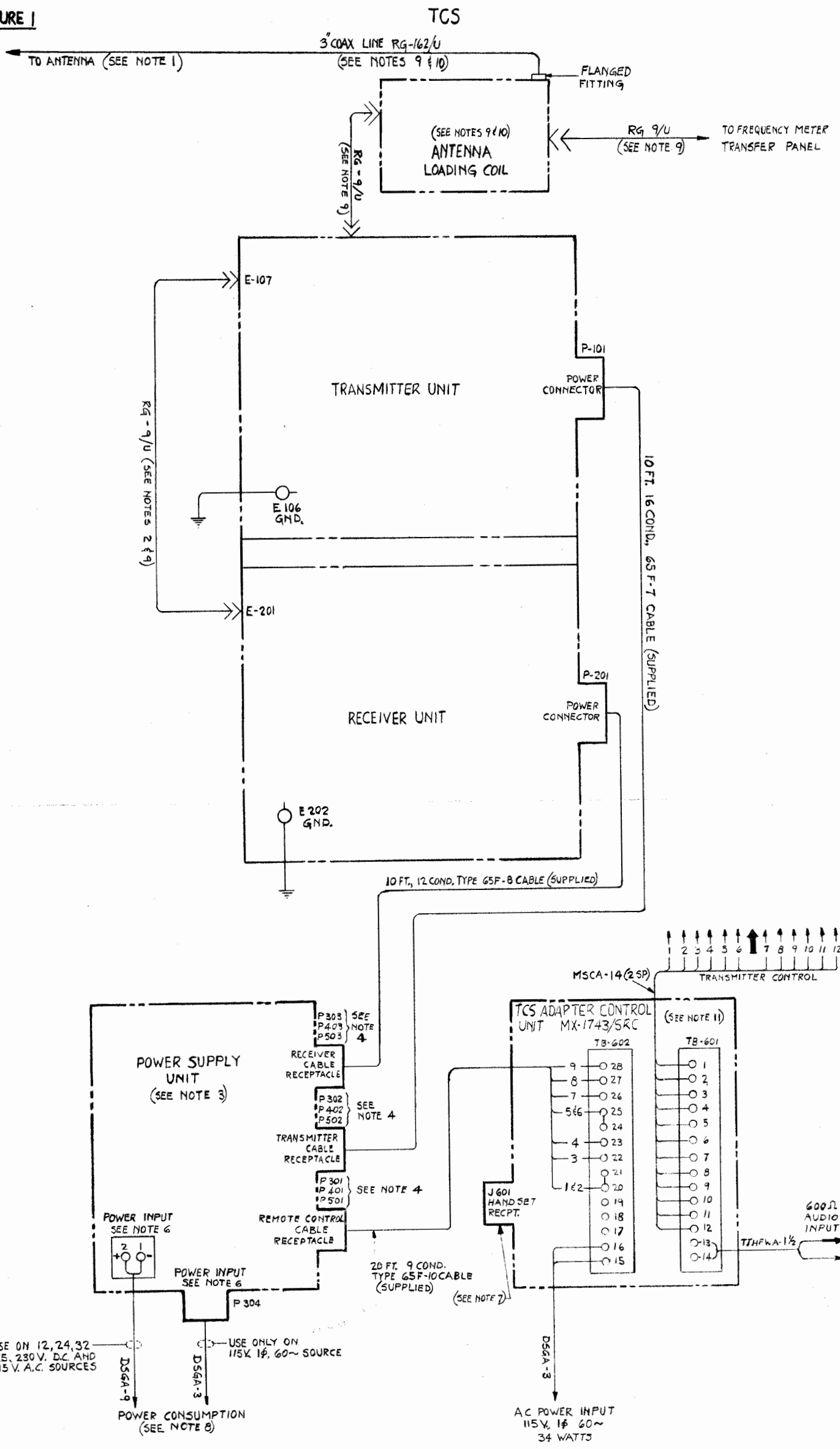

ORIGINAL

Figure 4-1. Adapter, Control MX-1743/SRC, Basic Communication System

UNCLASSIFIED

4-1
4-2

MX-1743/SRC
PRINCIPLES OF OPERATION

UNCLASSIFIED
NAVSHIPS 93084

Figure 4-1

NAVY MODEL	RCVR. AND TRANS. FREQUENCY RANGE	TYPE TRANSMISSION	NOMINAL R.F. POWER OUTPUT
TCS		A1	40 WATTS
		A3	20 WATTS

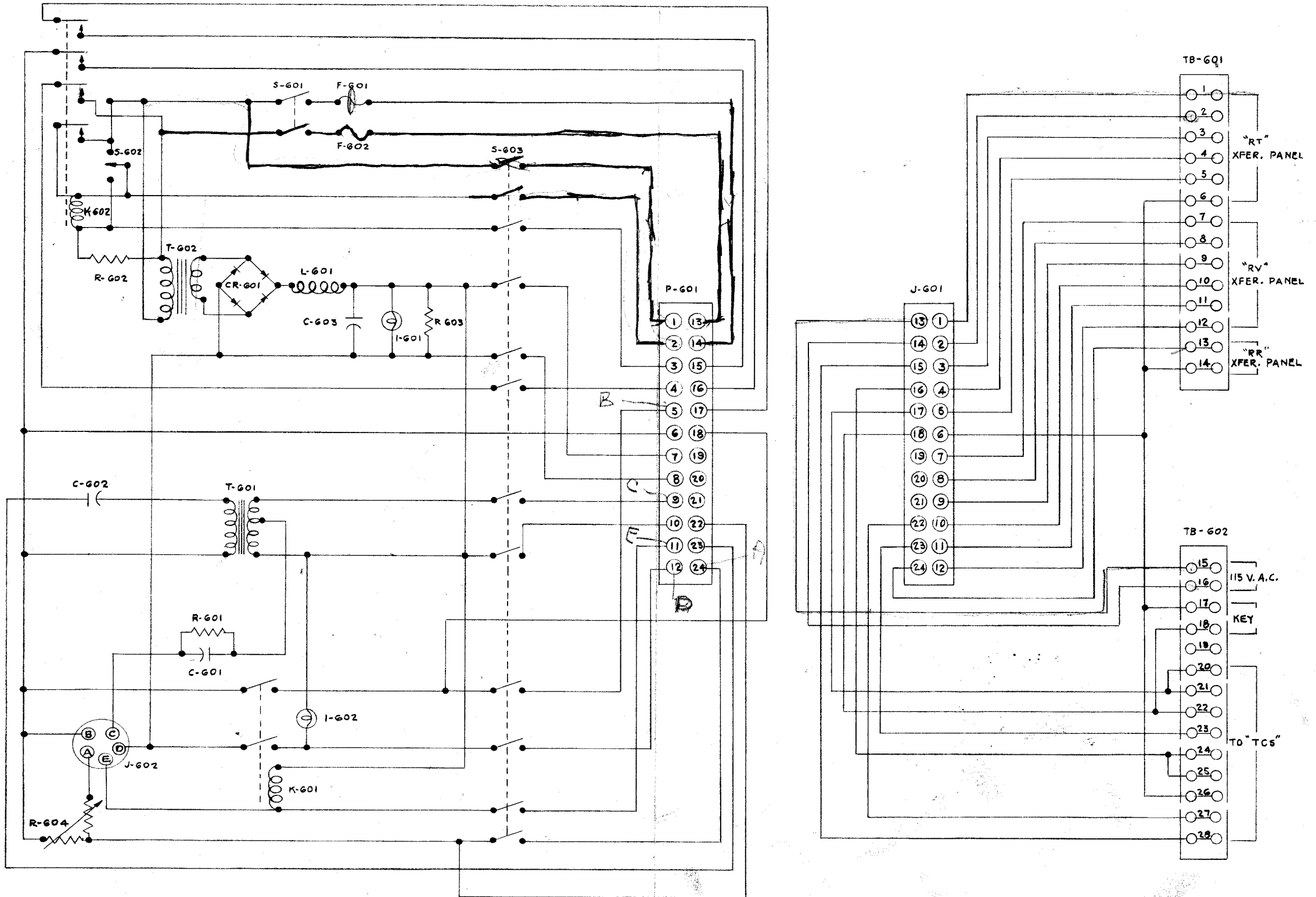

Figure 4-2. Adapter, Control MX-1743/SRC Schematic Wiring Diagram

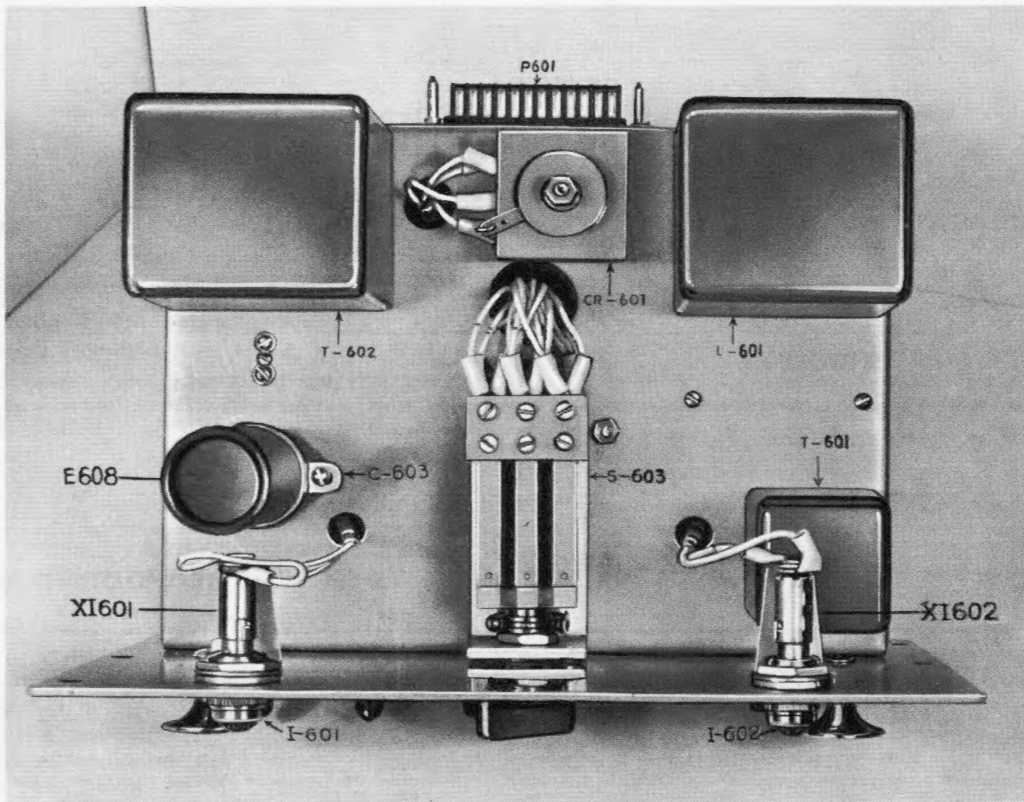

Figure 5-1. Adapter, Control, Panel and Chassis Assembly, Top View



Figure 5-2. Adapter, Control, Location of Test Points, Bottom of Chassis

SECTION 5 TROUBLE-SHOOTING

5-1. TEST EQUIPMENT AND SPECIAL TOOLS.

The only test equipment necessary is a Volt-Ohm-Ammeter Multitester.

5-2. OVERALL TROUBLE-SHOOTING.

a. PRELIMINARY CHECK.—Make a careful visual inspection of all items including: S-601 Adapter

“On-Off” Switch; S-602 TCS Adapter “Start-Stop” Switch; S-603 “Local-Remote” Switch; F-601 and F-602 Fuses; K-601 Relay, Pilot Lamps.

b. The above should be carefully checked for charred insulation and any visual physical damage before removing any of the components. Also check for loose cable and broken wires.

TABLE 5-1. ADAPTER, CONTROL MX-1743/SRC, SYSTEM TROUBLE-SHOOTING CHART

STEP	PRELIMINARY ACTION	NORMAL INDICATION	NEXT STEP
1	Chassis removed from panel. Apply 115 volts AC to Terminals #13 and #14 on P-601 (Plug). Close Switch S-601 (On-Off Switch).	“ADAPTER ON” indicator should light.	If pilot light does not light, check Fuses F-601-602. Check continuity of Switch S-601 (On-Off Switch). Check primary voltage of Power Transformer T-602. (Should read 115 volts.) Check secondary voltage of Power Transformer T-602. (Should read approximately 13 volts.) Check output voltage of Rectifier Stack CR-601. Check voltage across Pilot Lamp I-601.
2	Switch S-602 TCS Adapter in “Start” position.	Relay K-602 should operate and remain closed when Switch S-602 is released.	If Relay K-602 does not operate, check voltage across relay coil. Check continuity of Switch S-602.
3	“Local-Remote” Switch S-603 in “Local” (open) position. Plug hand set into J-602 Receptacle. Operate “Press-to-talk” switch on handset.	Relay K-601 will operate illuminating Pilot Lamp I-602.	If Relay K-601 does operate and Lamp I-602 does not light replace pilot lamp.

SECTION 6

REPAIR

6-1. FAILURE REPORT.

FAILURE REPORT

Report each failure of the equipment, whether caused by a defective part, wear, improper operation, or an external cause. Use ELECTRONIC FAILURE REPORT form DD787. Each pad of the forms includes full instructions for filling out the forms and forwarding them to the Bureau of Ships. However, the importance of providing complete information cannot be emphasized too much. Be sure that you include the model designation and serial number of the equipment (from the equipment identification plate), the type number and serial of the major unit (from the major unit identification plate), and the type number and reference designation of the particular defective part (from the technical manual). Describe the cause of the failure completely, continuing on the back of the form if necessary. Do not substitute brevity for clarity. And remember—there are two sides to the failure report—

YOUR SIDE

Every FAILURE REPORT is a boost for you:

1. It shows that you are doing your job.
2. It helps make your job easier.
3. It insures available replacements.
4. It gives you a chance to pass your knowledge to every man on the team.

Always keep a supply of failure report forms on board. You can get them from the nearest Forms and Publications Supply Point.

6-2. TUNING AND ADJUSTMENT.

TEST EQUIPMENT AND SPECIAL TOOLS.—A Volt-Ohm-Ammeter Multitester is required. In the event that a TCS equipment and a hand set are available, these would be helpful in localizing the troubles.

6-3. REMOVAL, ADJUSTMENT, REPAIR AND RE-ASSEMBLY OF PARTS AND SUB-ASSEMBLIES.

Refer to Figure 2-1.

Removal of the chassis and panel can be accomplished by removing the fourteen (14) screws from the front panel and slide the panel forward. Tracing the circuit by means of the Schematic Wiring Diagram, Figure 4-2, and pictorial diagrams of the chassis,

BUREAU SIDE

The Bureau of Ships uses the information to:

1. Evaluate present equipment.
2. Improve future equipment.
3. Order replacements for stock.
4. Prepare field changes.
5. Publish maintenance data.

Figures 5-1 and 5-2, will enable the proper location of the defective component part.

To remove the defective component part it is necessary to unsolder the leads carefully and remove the mounting screws. When the replacement part is replaced to its position make sure that the solder is well fused by exerting a light tension on the lead and check carefully any cracks in the solder. If cracks do appear, resolder the lead.

When the part has been replaced and circuit checks out satisfactory, replace the chassis back into the back box and make sure all the mounting screws in the front panel are tight.

Ratings of all component parts are shown in Section 7. Resistance values of resistors can be checked by means of an Ohmmeter.

SECTION 7

PARTS LIST

7-1. INTRODUCTION.

Reference designations have been assigned to identify all maintenance parts of the equipment. They are used for marking the equipment (adjacent to the part they identify) and are included on drawings, diagrams and the parts list. The letters of a reference designation indicate the kind of part (generic group) such as resistor, amplifier, electron tubes, etc. The number differentiates between parts of the same generic group. Sockets associated with a particular plug-in device, such as an electron tube or fuse, are identified by a reference designation which includes the reference designation of the plug-in device. For example, the socket for fuse F101 is designated XF101.

7-2. MAINTENANCE PARTS LIST.

Table 7-1 lists all major units and their maintenance parts. The parts of each major unit are grouped together. Column 1 lists the reference series of each major unit, followed by the reference designations of the various parts in alphabetical and numerical order. Column 2 refers to the explanatory notes that appear in paragraph 7-5 below. Column 3 gives the name and describes the various parts. Complete information is given for all key parts (parts differing from any part previously listed in this table) and sub-key parts (parts identical with a key part but appearing for the first time for a major unit). However, reference is made to the key part or sub-key part for the data. Column 4 indicates how the part is used and gives its functional location in the equipment.

7-3. STOCK NUMBER IDENTIFICATION.

Table 7-2 is arranged by key designation. The "Stock Number" column gives stock numbers for the various key parts. Therefore, if you have the reference designation for a part, you can easily locate the stock number.

7-4. LIST OF MANUFACTURERS.

Table 7-3 lists manufacturers of parts used in the equipment. The first column includes the abbreviations used in table 7-1 to identify manufacturers.

7-5. NOTES.

The following Source Maintenance and Recoverability Codes provide additional information concerning items listed in Table 7-1.

a. SOURCE CODES.

(1) P SERIES PARTS, PROCURED, SUPPLY SYSTEM STOCK.

(a) P—Applied to parts which are procured in view of relatively high usage and which are relatively simple to manufacture within the Naval Establishment if necessary. Code "P" indicates that the part is available in the supply system.

(b) P1—Applied to parts which are procured in view of relatively high usage but which are very difficult, impractical, or uneconomical to manufacture. Code "P1" indicates that the part is available in the supply system.

(c) P2—Applied to parts for which little usage is anticipated but which are procured in limited quantity for insurance purposes. Parts coded "P2" are difficult to manufacture, require special tooling not normally available within the Naval Establishment, or require long production lead time.

(d) P3—Applied to parts which are procured in quantity in accordance with the life expectancy of the part. Parts coded "P3" are deteriorative in nature and may require special storage conditions.

(2) M SERIES MANUFACTURE, PARTS NOT PROCURED.—M—Applied to parts which are capable of being manufactured within the Naval Establishment. Parts coded "M" have no anticipated or relatively low usage, or possess restrictive installation or storage factors. Code "M" will not be applied to an item when the item is coded "P" for other applications and system support is maintained; the item appears in the Navy Stock List of General Stores or the Navy Stock List of the Electronics Supply Office; or supply support responsibility for the item has been vested in another inventory manager.

(3) A—SERIES ASSEMBLY, ASSEMBLY NOT PROCURED.—A—Applied to assemblies which are not procured but which are to be assembled within the Naval Establishment prior to installation. At least one of the parts in the assembly must be a "P" series part which carries an individual part number and description.

(4) N SERIES NOT PROCURED OR STOCK, WILL BE PROCURED ON DEMAND.—N—Applied to parts which do not meet established criteria for stocking and which are normally readily available from commercial sources. Parts coded "N" will be procured on demand in accordance with applicable procedures.

(5) X SERIES NOT PROCURED, NORMALLY IMPRACTICABLE FOR STOCKING, MAINTENANCE OR MANUFACTURE.

(a) X—Applied to main structural members or similar parts which, if required, would suggest extensive repair. The need for a part, or parts, coded "X" will normally result in a recommendation for complete overhaul or retirement of the equipment from service.

(b) X1—Applied to parts for which procurement of the next larger assembly source coded "P" is justified; e.g., an internal detail part, such as welded segments inseparable from its assembly, a part of which must be machined and installed with other parts in a matched set, or a part of an assembly, which, if required, would suggest extensive reconditioning of such assembly.

(c) X2—Applied to parts which are not procured for stock but may be acquired for use through salvage. Activities requiring such parts will attempt to obtain salvage; if not obtainable from salvage, such parts will be requisitioned through normal supply channels with supporting justification. Repeated requests may justify a change to a "P" source code.

(6) U SERIES NOT PROCURED, NOT OF SUPPLY OR MAINTENANCE SIGNIFICANCE.—U—Applied to parts which are not of supply maintenance significance, such as installation drawings, diagrams, instruction sheets, field service drawing numbers and parts which should not or cannot be procured or manufactured (optional).

b. MAINTENANCE CODES.

CODE	MAINTENANCE ECHELON
O	Overhaul activities.
T	Tender or Repair Ship.
F	Activity to which equipment is assigned (e.g. vessel, FASRON or self-supported squadron).
E	Specialized repair facilities.
B	Specific maintenance requirements not applicable (optional).

c. RECOVERABILITY CODES.

(1) CODE DEFINITION AND APPLICATION OF CODE.

(a) R—Repairable parts which are uneconomical and practical to repair. Replacements will be obtained and expended parts returned in accordance with instructions issued by the inventory manager.

(b) S—Salvageable parts which are economical and practical to salvage and which may be placed in "Ready for Issue" condition by cleaning, replating, anodizing, adjusting, replacement of bearings or bushings. "S" coded parts may contain parts or materials which are usable, valuable or critical, and which may be placed in the supply system for issue.

(c) C—Consumable (expendable) parts that are neither repairable nor salvageable (optional).

d. CODE FORMAT.—In assigning the above listed codes, the following sequence has been followed:

SOURCE	MAINTENANCE		RECOVERABILITY
(1)	(2)	(3)	(4)
Consumer Source Information	Lowest Maintenance Echelon capable of installing parts	Lowest Maintenance Echelon capable of manufacturing, assembling or testing a part prior to installation	Recoverability status

TABLE 7-1. ADAPTER, CONTROL MX-1743/SRC, MAINTENANCE PARTS LIST

REF. DESIG.	NOTES	NAME AND DESCRIPTION	LOCATING FUNCTION
A-601	P2FFC	KNOB, NICKEL PLATED BRASS: HOLLINGSWORTH Part No. A-4016-15	
C-601	P1FFC	CAPACITOR: Bathtub, 100 mfd. AEV type BT 25 V.	Bias
C-602	P1FFC	CAPACITOR: Bathtub, 8 mfd. 450VDCW, AEV type BT, 450 V.	Input Filter
C-603	P1FFC	CAPACITOR: 1000 mfd., 15 VDCW, AEV AFH1-02	Rectifier Filter
CR-601	P1FFC	RECTIFIER, SELENIUM: Single phase, full wave bridge, ITRC, C1B1STBGX	Rectifier
E-601	P2FFC	KNOB, VOLUME CONTROL, BAKELITE: Molded Insulation Co., Part No. V12-A	R-604 Resistor
E-602	PFFC	GROMMET, RUBBER: For $\frac{3}{8}$ " hole, $\frac{1}{16}$ " panel	Chassis
E-603	PFFC	GROMMET, RUBBER: For $\frac{3}{4}$ " hole	Chassis
E-604	PFFC	GROMMET, RUBBER: For $\frac{5}{16}$ " hole	Chassis
E-605	P2FFC	SEAL, TOGGLE SWITCH: Automatic Precision Mfg. Co., Part No. Hexseal 1030	Toggle Cover
E-606	MFFC	GASKET, NEOPRENE: $\frac{1}{16}$ " thick, JOHN R. HOLLINGSWORTH, Dwg. No. B-SK-111-1	Front Panel
E-607	MFFC	GASKET, NEOPRENE: $\frac{1}{16}$ " thick, JOHN R. HOLLINGSWORTH, Dwg. No. A-4016-42	Handset Receptacle J-602
E-608	NFFC	INSULATING TUBE, PAPER: 1" I.D., Sangamo Electric Co., Part No. KCT-3	HSG. for C-603
F-601	P1FFC	FUSE: 3 amp. BUS part HES, $1\frac{1}{2}$ " long x $\frac{3}{32}$ " diameter, glass tube	Rectifier Protection
F-602	P1FFC	Same as F-601	
I-601	P1FFC	LAMP, MINIATURE BAYONET: 12-16 V., GE Part No. G-53	Pilot Lamps
I-602	P1FFC	Same as I-601	
J-601	P2FFC	RECEPTACLE: 24 contacts, AMP Part No. 26-190-24	Stationary Back Box Receptacle
J-602	P2FFC	RECEPTACLE: 5 contacts, AMP Part No. AN-3102A-14S-5S	Handset Receptacle
K-601	P1FFC	RELAY: 12 VDC coil, contacts DPST, N.O., 2 amp., ADE Part No. MG2A12VD	Handset Energized Relay
K-602	P1FFC	RELAY: 60 VAC coil, contacts 4PST, N.O., 5 amp., ADE Part No. TF4A60VA	Adapter on Relay
L-601	P1FFC	REACTOR: 0.2 Hy., 1 amp., HJR Part No. 4022-1, MIL-T-27, Grade 1, Class A	Rectifier Filter Choke
P-601	P2FFC	PLUG: 24 contacts, AMP Part No. 26-159-24	Chassis Plug
R-601	P1FFC	RESISTOR, FIXED, CARBON COMP.: 120 ohms, 2 watt, 5%, AB, IRC Part No. BTD	Bias
R-602	P1FFC	RESISTOR, FIXED, PRECISION WIRE WOUND: 350 ohms, 50 watt, 3%, DABU Part No. RH-50	K-602 Blocking Resistor
R-603	P1FFC	RESISTOR, FIXED, PRECISION WIRE WOUND: 150 ohms, 25 watt, 3%, DABU Part No. RH-25	Rectifier Bleeder
R-604	P1FFC	RESISTOR, VARIABLE, WIRE WOUND: 600 ohm, dual pad, 4 watt, CTS type 2-25-H-5695	Handset Receptacle Volume Control

TABLE 7-1. ADAPTER, CONTROL MX-1743/SRC, MAINTENANCE PARTS LIST (Cont.)

REF. DESIG.	NOTES	NAME AND DESCRIPTION	LOCATING FUNCTION
S-601	P1FFC	SWITCH, TOGGLE, DPST: Bat. handle solder terminals, 250 V., 10 amp., CELI Part No. ST-52K	Rectifier Bleeder
S-602	P1FFC	SWITCH, TOGGLE, SPDT: Start-stop, center off momentary on both sides, CELI Part No. ST-42G	Carrier on Switch
S-603	P1FFC	SWITCH, LOCAL-REMOTE, ROTARY TRANSMITTER: Navy type 241302. Navy drawing RE24D173 Rev. G.	Local-Remote Switch
T-601	P1FFC	TRANSFORMER, INPUT: HJR Part No. 4021-1	Signal Transformer
T-602	P1FFC	TRANSFORMER, POWER: Primary, 110 V.; Secondary, 17 V., 1.0 amp., HJR Part No. 4023-1	Rectifier Power
TB-601	MFFC	TERMINAL BOARD: 14 terminals, 5-40 x 3/16 Screws, CINS Part No. 14-140	Back Box Terminal Board
TB-602	MFFC	Same as TB-601	
XF-601	P2FFC	HOLDER, FUSE: Panel mounted, bayonet knob, solder terminals, Bussman type HCM	
XF-602	P2FFC	Same as XF-601	
XI-601	P2FFC	LAMP BASE, MINIATURE BAYONET, GREEN FACETED LENS: Dialight Corp. Part No. 810B-431 per MIL-L-3661 #LH50-FR2	Pilot Lights
XI-602	P2FFC	Same as XI-601	

TABLE 7-2. STOCK NUMBER IDENTIFICATION TABLE

REFERENCE DESIGNATION	FEDERAL STOCK NUMBERS
A-601	G5340-291-8714
C-601	N5910-195-8532
C-602	N5910-666-5419
C-603	N5910-196-1619
CR-601	N6130-635-5683
E-601	N5355-160-6132
E-602	N5325-263-6632
E-603	N5325-286-0332
E-604	N5325-286-5809
E-605	N5975-099-5747
E-606	G5330-244-0191
E-607	G5330-244-0191
E-608	<i>For reference only</i>
F-601	N5920-665-0573
F-602	N5920-665-0573
I-601	G6240-013-1282
I-602	G6240-013-1282
J-601	N5935-259-3966
J-602	N5935-230-1561
K-601	N5945-557-9303
K-602	N5945-524-3396
L-601	
P-601	N5935-258-2974
R-601	N5905-279-2596
R-602	N5905-557-9544
R-603	N5905-636-6064
R-604	N5905-256-6396
S-601	N5930-050-2704
S-602	N5930-050-2686
S-603	N5930-548-5542
T-601	
T-602	N5950-693-4694
TB-601	N5940-109-2582
TB-602	N5940-109-2582
XF-601	G5920-247-3818
XF-602	G5920-247-3818
XI-601	N6210-299-4018
XI-602	N6210-299-4018

TABLE 7-3. ADAPTER, CONTROL MX-1743/SRC, LIST OF MANUFACTURERS

ABBREVIATION	NAME	ADDRESS
ADE	Advance Electric and Relay Division, Elgin National Watch Co.	2435 N. Naomi St., Burbank 28, Calif.
AEV	Aerovox Corporation	740 Belleville Ave., New Bedford, Mass.
AMP	Amphenol Electronics Corp.	1830 S. 54th Ave., Chicago 50, Ill.
ATFG	Atlantic Felt & Gasket Company	Torresdale and Frankford Aves., Philadelphia 24, Pa.
BUS	Bussmann Manufacturing Company....	2534 W. University Ave., St. Louis, Mo.
CELI	Carling Electric, Inc.	495 New Park Ave., Hartford, Conn.
CPH	Chicago Telephone Supply Company...	1142-1232 W. Beardsley Ave., Elkhart, Ind.
CINS	Cinch Manufacturing Corporation....	1028 S. Homan St., Chicago, Ill.
DABU	Dale Products, Incorporated	Plant St., Columbus, Neb.
DLC	Dialight Corporation	60 Stewart Ave., Brooklyn 37, N. Y.
EN	Elastic Stop Nut Corp. of America....	2330 Vauxhall Rd., Union, N. J.
GLEC	General Electric Company	Nela Park, Cleveland 12, Ohio
GUDA	Gudebrod Brothers Silk Co., Inc.	Pottstown, Pa.
HJR	John R. Hollingsworth	Nutt and French Creek Rds., Phoenixville, Pa.
ITRC	International Rectifier Corp.	1521 E. Grand Ave., El Segundo, Calif.
IRC	International Resistance Company	401 N. Broad St., Philadelphia 8, Pa.
MAL	P. R. Mallory & Company, Inc.	3029 E. Washington St., Indianapolis, Ind.
NEMS	Nems-Clarke, Incorporated	919 Jesup-Blair Drive, Silver Springs, Md.
PLQ	Plastoid Corporation	42-61 24th St., Long Island City 1, N. Y.
SMD	Sangamo Electric Company	11th and Converse Sts., Springfield, Ill.