

★  
NAVSHIPS 0967-292-9020

VOLUME 2  
TECHNICAL MANUAL

*for*

KEYER, FREQUENCY SHIFT  
KY-655/FRT

*Used with:*

AN/FRT-83(V) 1 KW HF ISB TRANSMITTER  
AN/FRT-84(V) 10 KW HF ISB TRANSMITTER  
AN/FRT-85(V) 40 KW HF ISB TRANSMITTER  
AN/FRT-86(V) 200 KW HF ISB TRANSMITTER

DEPARTMENT OF THE NAVY  
NAVAL ELECTRONIC SYSTEMS COMMAND

★  
*Publication: 15 October 1969*

*Change 1: 1 May 1971*

KY-655/FRT

INTERIM DATA

1.1 INSTRUCTIONS

1.1.1 These corrections for NAVSHIPS 0967-292-9020 (Vol. 2, Technical Manual for Keyer, Frequency Shift KY-655/FRT) are supplied as pack-up data to provide field personnel with current information on changes.

1.1.2 Make pen-and-ink corrections as indicated on corrected page, cross out "CHANGE 1" at the bottom of the page and insert "INTERIM DATA CHANGE".

1.2 PEN-AND-INK CORRECTIONS

Page 5-47/5-48, figure 5-23, Cable Interconnection Diagram (Sheet 2 of 2): Just below center at left of figure 5-23, locate line between A7J1-D and A6J2-J. On this line and immediately to the left of the dotted line indicating a shield cable, add a dot and ground symbol to show pin A7J1-D is grounded to the case of the KY-655/FRT.

IMPORTANT

Read above instructions before consulting any of the publications or changes to publications shipped with this equipment.

## LIST OF EFFECTIVE PAGES

PAGE NUMBERS	CHANGE IN EFFECT	PAGE NUMBERS	CHANGE IN EFFECT
Title Page	Change 1	5-47/5-48	Change 1
ii	Change 1	6-1 to 6-5	Original
iii to v	Original	6-6	Change 1
vi Blank	Original	6-7 to 6-8	Original
vii	Original	6-9	Change 1
1-0 to 1-4	Original	6-10 to 6-12	Original
2-1 to 2-10	Original	6-13 to 6-14	Change 1
3-1 to 3-7	Original	6-15	Original
4-1 to 4-10	Original	6-16	Change 1
4-11/4-12	Change 1	6-17 to 6-21	Original
4-13 to 4-20	Original	6-22	Change 1
5-1 to 5-16	Original	6-23/6-24	Original
5-17 to 5-18	Change 1	i-1 to i-4	Original
5-19 to 5-46	Original		

RF Communications, 1680 University Ave., Rochester, New York 14610

Errors found in this publication (other than obvious typographical errors) which have not been corrected by means of Temporary Corrections or Permanent Changes should be reported. Such report should include the complete title of the publication and the publication number (short title); identify the page and line or figure and location of the error; and be forwarded to the Technical Publications Branch, Headquarters, Naval Electronic Systems Command (Code 0453) Washington, D.C. 20360.

All Navy requests for NAVSHIPS electronics publications listed in the current issue of NAVSANDA Publication 2002 "NAVY STOCK LIST OF FORMS AND PUBLICATIONS" Cognizance Symbol I, or in a subsequent issue of the Electronics Information Bulletin should be directed to the appropriate Forms and Publications Supply Point.

## TABLE OF CONTENTS

Paragraph		Page
SECTION 1 - GENERAL INFORMATION		
1-1.	Introduction . . . . .	1-1
1-2.	Functional Description . . . . .	1-1
1-3.	Quick Reference Data . . . . .	1-2
1-4.	Equipment Lists . . . . .	1-3
SECTION 2 - INSTALLATION		
2-1.	Unpacking and Handling . . . . .	2-1
2-2.	Power Requirements and Distribution . . . . .	2-2
2-3.	Installation Planning . . . . .	2-2
2-4.	Installation Requirements . . . . .	2-4
2-5.	Initial Operating Tests . . . . .	2-8
2-6.	Preparation for Reshipment . . . . .	2-10
SECTION 3 - OPERATION		
3-1.	Functional Operation . . . . .	3-1
3-2.	Operating Procedures . . . . .	3-1
3-3.	Summary of Operation . . . . .	3-6
3-4.	Emergency Operation . . . . .	3-6
3-5.	Operator's Maintenance . . . . .	3-7/3-8
SECTION 4 - TROUBLE SHOOTING		
4-1.	Introduction . . . . .	4-1
4-2.	Logical Trouble Shooting . . . . .	4-1
4-3.	Over-all Functional Description . . . . .	4-2
4-4.	TTY Selector (A1) . . . . .	4-5
4-5.	Keyer and Transition Relay (A2) . . . . .	4-5
4-6.	FS Oscillator (A3) . . . . .	4-6
4-7.	Frequency Calibration (A4) . . . . .	4-7
4-8.	Audio Amplifier (A5) . . . . .	4-8
4-9.	Power Supply (PS1) . . . . .	4-9
4-10.	Service Block Diagrams . . . . .	4-10
SECTION 5 - MAINTENANCE		
5-1.	Introduction . . . . .	5-1
5-2.	Tuning and Adjustment . . . . .	5-1
5-3.	Repair . . . . .	5-14
5-4.	Removal and Replacement . . . . .	5-14
5-5.	Maintenance Illustrations . . . . .	5-16

TABLE OF CONTENTS (Cont)

Paragraph		Page
SECTION 6 - PARTS LIST		
6-1.	Introduction . . . . .	6-1
6-2.	Reference Designations . . . . .	6-1
6-3.	List of Units . . . . .	6-2
6-4.	Maintenance Parts List . . . . .	6-2
6-5.	Special Tools and Equipment . . . . .	6-2
6-6.	List of Manufacturers . . . . .	6-2
6-7.	Stock Number Identification . . . . .	6-2

LIST OF ILLUSTRATIONS

Figure		Page
SECTION 1 - GENERAL INFORMATION		
1-1.	Keyer, Frequency Shift KY-655/FRT . . . . .	1-0
SECTION 2 - INSTALLATION		
2-1.	Keyer, Frequency Shift KY-655/FRT, Outline Drawing . .	2-3
2-2.	Location of External Cable Connections to Keyer . . . . .	2-5
2-3.	Primary Power Cable, Assembly Procedure . . . . .	2-6
2-4.	Data Cable, Assembly Procedure . . . . .	2-7
SECTION 3 - OPERATION		
3-1.	Frequency Shift Keyer KY-655/FRT, Location of controls and Indicators . . . . .	3-2
SECTION 4 - TROUBLE SHOOTING		
4-1.	System Basic Block Diagram . . . . .	4-3
4-2.	Keyer, Functional Block Diagram . . . . .	4-4
4-3.	Keyer, Over-all Block Diagram . . . . .	4-11/4-12
4-4.	Keyer and Transition Relay Assembly (A2), Service Block Diagram . . . . .	4-13/4-14
4-5.	FS Oscillator Assembly (A3), Service Block Diagram . .	4-15/4-16
4-6.	Audio Amplifier Assembly (A5), Service Block Diagram . . . . .	4-17/4-18
4-7.	Power Supply Assembly (PS1), Service Block Diagram . . . . .	4-19/4-20
SECTION 5 - MAINTENANCE		
5-1.	Assembly and Component Location Diagram, (Sheet 1 of 2) . . . . .	5-17
5-1.	Assembly and Component Location Diagram, (Sheet 2 of 2) . . . . .	5-18
5-2.	TTY Selector (A1), Component Location Diagram . . . . .	5-19

## LIST OF ILLUSTRATIONS (Cont)

Figure		Page
SECTION 5 - MAINTENANCE (Cont)		
5-3.	Keyer and Transition Relay (A2), Component Location Diagram . . . . .	5-20
5-4.	Frequency Shift Oscillator (A3), Component Location Diagram . . . . .	5-21
5-5.	Oscillator Board No. 1 (A3A1), Component Location Diagram . . . . .	5-22
5-6.	Oscillator Board No. 2 (A3A2), Component Location Diagram . . . . .	5-23
5-7.	Frequency Calibration (A4), Component Location Diagram . . . . .	5-23
5-8.	Audio Amplifier (A5), Component Location Diagram . . .	5-24
5-9.	Power Supply (PS1), Component Location Diagram . . . .	5-25
5-10.	Relay Control (PS1A1), Component Location Diagram . . .	5-26
5-11.	±10 VDC Regulator (PS1A2), Component Location Diagram . . . . .	5-26
5-12.	±18 VDC Regulator (PS1A3), Component Location Diagram . . . . .	5-27
5-13.	Rectifier/Filter (PS1A4), Component Location Diagram . . . . .	5-27
5-14.	Frequency Shift Oscillator (A3), Disassembly Diagram . .	5-28
5-15.	Power Supply (PS1), Removal of Printed Circuit Boards . . . . .	5-28
5-16.	AC Distribution Diagram . . . . .	5-29/5-30
5-17.	TTY Selector A1, Schematic Diagram . . . . .	5-31/5-32
5-18.	Keyer and Transition Relay (A2), Schematic Diagram . . .	5-33/5-34
5-19.	Frequency Shift Oscillator (A3), Schematic Diagram . . .	5-35/5-36
5-20.	Frequency Calibration Assembly (A4), Schematic Diagram . . . . .	5-37/5-38
5-21.	Audio Amplifier (A5), Schematic Diagram . . . . .	5-39/5-40
5-22.	Power Supply (A1PS1), Schematic Diagram (Sheet 1 of 2) . . . . .	5-41/5-42
5-22.	Power Supply (A1PS1), Schematic Diagram (Sheet 2 of 2) . . . . .	5-43/5-44
5-23.	Cable Interconnection Diagram (Sheet 1 of 2) . . . . .	5-45/5-46
5-23	Cable Interconnection Diagram (Sheet 2 of 2) . . . . .	5-47/5-48

## LIST OF TABLES

Table		Page
SECTION 1 - GENERAL INFORMATION		
1-1.	Equipment Supplied . . . . .	1-4
1-2.	Equipment Required But Not Supplied . . . . .	1-4
SECTION 2 - INSTALLATION		
2-1.	Connectors Supplied and External Cable Requirements . . .	2-5
SECTION 3 - OPERATION		
3-1.	Operating Controls and Devices . . . . .	3-3
3-2.	Operating Modes and Outputs . . . . .	3-4
3-3.	Circuit Test Measurements . . . . .	3-5
3-4.	Keyer, Frequency Shift KY-655/FRT, Summary of Operation . . . . .	3-6
SECTION 5 - MAINTENANCE		
5-1.	Test Equipment . . . . .	5-1
5-2.	Preliminary Control Settings . . . . .	5-2
5-3.	Frequency Calibration (A4) and Keyer and Transition Relay (A2) Voltage Check . . . . .	5-8
5-4.	Resistance Values of A4R6 for Various Frequency Ranges. . . . .	5-13



Figure 1-1. Keyer, Frequency Shift KY-655/FRT



SECTION 1  
GENERAL INFORMATION

1-1. INTRODUCTION.

Keyer, Frequency Shift KY-655/FRT consists of a chassis assembly and enclosure, that supplies signals in modulation modes A1 (cw), F1 (fsk), and F4 (facsimile/analog) to Modulator-Synthesizer MD-777/FRT. The unit is intended for installation in a standard relay rack or cabinet.

1-2. FUNCTIONAL DESCRIPTION.

Keyer, Frequency Shift KY-655/FRT is an electronic keyer which accepts cw (key), teletype, or facsimile analog inputs (selectable by a 5-position, front-panel switch) at speeds up to 400 bauds.

The keyer employs a highly stable, voltage-controlled oscillator circuit to provide a 1000-cps signal for cw keying, and a frequency-shift signal for teletype or facsimile operation. The frequency-shift signal is selectable about the following center frequencies by means of a 4-position, front-panel switch:

- a. 1900 cps.
- b. 2000 cps.
- c. 2550 cps.
- d. Selectable frequency (customer option).

When operating in the teletype keying mode, the frequency deviation about the center frequency is continuously variable from 0 to 1000 cps by a front-panel readout control.

The keyer is also a transition detector. It incorporates a relay which cycles Modulator-Synthesizer MD-777/FRT to an "off-the-air" condition in A1 and F1 modes when the input goes into a sustained "mark", "space", or receiving mode during operation, thus preventing unwanted transmissions. The release time of the relay is manually adjustable over a 100 msec to a 5 second range. The attack time is less than 1 msec. (A strapping option allows control of the relay by an external switch.) A changeover relay is also provided which allows an external audio line input to appear at the output of the keyer when CLASS OF EMISSION A1F1F4 is not selected.

Operating functions of the keyer are performed using front-panel controls. The keyer may be switched to the "standby" or "operate" mode at either the Modulator-Synthesizer MD-777/FRT (exciter) or Control-Indicator, Transmitter C-7709/FRT (remote control unit).

The chassis assembly is mounted in the enclosure on a retractable slide mechanism. The mechanism permits extension of the chassis as a drawer, and rotation of the chassis over a 90° arc to expose all modules for inspection and maintenance. Modular construction with printed circuit boards is used extensively in the unit. For operation, the keyer requires a primary power source of 115/230 volts ac, 50/60 cycles, single phase. Standby power requirements are approximately 28 watts and full power requirements are approximately 30 watts.

1-3. QUICK REFERENCE DATA.

a. GENERAL.

- (1) NOMENCLATURE: Keyer, Frequency Shift KY-655/FRT.
- (2) CONTRACT NUMBER: N00600-67-C-0589.
- (3) DATE OF CONTRACT: 15 February 1967.
- (4) CONTRACTOR: RF Communications, Inc., Rochester, New York, 14610, U.S.A.
- (5) COGNIZANT INSPECTOR: DCASR, Boston, Massachusetts.
- (6) NUMBER OF PACKAGES: 1.

b. FUNCTIONAL CHARACTERISTICS.

- (1) PRIMARY POWER REQUIREMENTS:
  - (a) Voltage: 115/230 vac ( $\pm 10\%$ ); frequency: 50/60 cps ( $\pm 5\%$ ), single phase.
  - (b) Current: Operating, 0.25 (115V); 0.125 (230V) amps.
  - (c) Power: Operating, 30 watts; standby, 28 watts.
- (2) KEYSIGNAL INPUTS:

<u>Input Signal (Mode)</u>	<u>Input Impedance</u>	<u>Operating Differential</u>
Cw (A1)	47,000 ohms	N/A
TTY (F1), 20 ma neutral	147 ohms	8.5 - 11.5 ma $\pm 1$ ma
TTY (F1), 60 ma neutral	47 ohms	25.5 - 34.5 ma $\pm 3$ ma
TTY (F1), 50 volts neutral	47,000 ohms	21 - 29 volts $\pm 2.5$ V
TTY (F1), 100 volts neutral	100,000 ohms	42 - 58 volts $\pm 5$ V
TTY (F1), dry relay contacts	47,000 ohms	N/A
TTY (F1), polar	100,000 ohms	$\pm 200$ mv $\pm 50$ mv
Facsimile (F4)	600 ohms	$\frac{+1V \text{ to } +10V}{800 \text{ cps shift}}$

(3) KEYSIGNAL OUTPUT FREQUENCIES:

- (a) 1000 cps tone (A1 operation); (2000 cps optional).
- (b) 1900 cps center frequency (F1 and F4 operation).

- (c) 2000 cps center frequency (F1 and F4 operation).
- (d) 2550 cps center frequency (F1 and F4 operation).
- (e) Optional center frequency, 400 cps to 3000 cps.
- (4) KEYER OUTPUT LEVEL: Adjustable from -10 dbm to +3 dbm.
- (5) KEYER OUTPUT LEVEL CHANGE: Less than 0.5 db at 1000 cps deviation.
- (6) KEYER OUTPUT IMPEDANCE: 600 ohms  $\pm 5\%$ .
- (7) HUM AND NOISE: -65 dbm or less (transition relay open).
- (8) TOTAL HARMONIC DISTORTION: -42 db or better (500 to 3000 cps).
- (9) KEYING RATE: 0 to 400 bauds.
- (10) FACSIMILE LINEARITY: Within  $\pm 9$  cps from +1 to +10 volt input range.
- (11) TELETYPE LINEARITY:  $\pm 1$  cps  $\pm 1\%$  of dial reading for any TTY DEVIATION CPS dial setting from 012 to 1000.
- (12) FREQUENCY STABILITY:  $\pm 1$  cps per day.
- (13) TRANSITION RELAY CLOSURE TIME: Less than 1 millisecond.
- (14) TRANSITION RELAY DELAY TIME: Adjustable from 100 milliseconds to 5 seconds.

1-4. EQUIPMENT LISTS.

- a. EQUIPMENT SUPPLIED. - Table 1-1 lists the names, quantities, dimensions, and weights of all equipment supplied.
- b. EQUIPMENT REQUIRED BUT NOT SUPPLIED. - Table 1-2 lists the equipment required for keyer operation but not supplied.
- c. SHIPPING DATA. - Table 1-1 includes all essential data required for shipping.

TABLE 1-1. EQUIPMENT SUPPLIED

QTY PER EQUIP.	NOMENCLATURE		DIMENSIONS (IN.)			VOL (CU FT)	WT (LBS)
	NAME	DESIG	HGT	W	D		
1	Keyer, Frequency Shift	KY-655/FRT	3.5	19	22.5	.85	40
2	Technical Manual	NAVSHIPS 0967-292-9020	10.75	8.25	0.50		
2	Maintenance Standards Book	NAVSHIPS 0967-293-4010	10.75	8.25	0.25		
Bulk only	Overhaul and Repair Instructions	NAVSHIPS 0967-293-4020	10.75	8.25	0.25		
1	Cable Assembly	D45336G1	See Parts List				
1	Connector	MS3108R14S-7S	See Parts List				
1	Connector	MS3116F14-15SW	See Parts List				
1	Extender Cable	C45629G1	See Parts List				
1	Extender Cable	C45630G1	See Parts List				

TABLE 1-2. EQUIPMENT REQUIRED BUT NOT SUPPLIED

QTY PER EQUIP.	NOMENCLATURE		USE	KEYER CHARACTERISTICS
	NAME	DESIGNATION		
1	Differential Voltmeter	Fluke Model 883AB	Trouble shooting and maintenance procedures ↑ ↓	±1 vdc to ±28 vdc
1	Multimeter	AN/PSM-6		0 to 100 ma
1	Frequency Counter	AN/USM-207 (with video amplifier)		0 to 3000 cps
1	Oscilloscope	Tektronix 585A with Type 82 plug-in unit		0 to 3000 cps
1	DC Power Supply	Power Designs, Inc. Model 4005		0 to 100 vdc, 0 to 60 ma
1	Audio Signal Generator	H-P Model 206A		50 cps - 2000 cps
1	Audio Level Meter	H-P Model 403A		-20 to +10 dbm
1	Shunt Resistor	H-P Model 11033A		600Ω, 1/4W

SECTION 2  
INSTALLATION

2-1. UNPACKING AND HANDLING.

a. DESCRIPTION OF PACKAGING AND PACKING METHODS. - Keyer, Frequency Shift KY-655/FRT and accessories are packed for shipment in a wooden box and carton, packaged as follows:

(1) The keyer and two copies of the technical manual are contained in a carton. End spacers in the carton contain bags of dessicant. A waterproof, vaporproof barrier surrounds the keyer carton. The technical manuals, in sealed envelopes, are packed on top of the carton outside of the barrier. This package is surrounded by an outer carton.

(2) The packaged keyer and technical manuals are enclosed in a wooden box, reinforced with metal bands. Refer to table 1-1 for a complete list of the items supplied.

b. UNPACKING INSTRUCTIONS.

- (1) Observe markings on the wooden box and place it on a flat surface with the top up.
- (2) Release the reinforcing bands to permit removal of a side panel of the box.
- (3) Use a nail puller and remove the box side panel.
- (4) Open the inner carton and remove the technical manuals.
- (5) Cut open the waterproof liner.
- (6) Open the inner carton and remove contents.
- (7) Check the contents against the list in table 1-1.

c. HANDLING. - Normal precautions for lifting and transporting electronic equipment should be observed when handling the keyer. It may be lifted by the panel handles or grasped at the enclosure corners if convenient.

d. MECHANICAL INSPECTION. - Directly following unpacking and before installation, inspect the keyer to detect any damage which may have occurred during shipment. A check of the following items may avoid much inconvenience during installation and initial equipment operation.

- (1) Check for nuts, washers, or other foreign particles which may be lodged where they could cause a short circuit.
- (2) Tighten any screws or nuts on mechanical assemblies which may have worked loose.

(3) Look for broken wires or loose cable connections.

(4) Operate all mechanical controls through their full range of travel to detect jammed controls, bent control shafts, or other evidence of mechanical damage.

(5) See that all plug-in modules and cable connections are seated in their sockets.

## 2-2. POWER REQUIREMENTS AND DISTRIBUTION. (See figure 5-16.)

a. REQUIREMENTS. - The keyer is to be operated from a primary power source of 115 or 230 volts ac, 50 to 60 cycles, single phase. The voltage tolerance is  $\pm 10\%$  and the frequency tolerance is  $\pm 5\%$ . These tolerances should not be exceeded.

b. PRIMARY POWER CONNECTIONS. - Primary power connections to the keyer require attachment of a power input cable. Table 2-1 lists the cables and connections for all external cables required but not supplied which are attached to the keyer.

c. DISTRIBUTION. - The primary power distribution diagram (figure 5-16) illustrates the distribution of ac power circuits within the keyer. Primary ac power, via the ac power input filter A7FL1 at input connector A6J2, passes through the overload circuit breaker A6CB1 and the 115/230 volt power selection switch A6S3 to the power supply transformer PS1T1. Circuit breaker CB1 opens and removes primary power if the current exceeds 1.0 amperes, and can be reset manually.

## 2-3. INSTALLATION PLANNING. (See figure 2-1.)

Keyer, Frequency Shift KY-655/FRT is intended for installation in a standard relay rack or cabinet with Modulator-Synthesizer MD-777/FRT and Decoder-Encoder KY-656/FRT. Facilities are provided for interconnection with these units. In selecting a suitable location for installation, the following factors should be considered:

a. POWER SOURCE. - The power source described in paragraph 2-2a must be available at the location for keyer operation.

b. CABLE LENGTHS. - The length of connecting cables to the transmitter is not critical.

c. SERVICE ACCESS. - The keyer design permits most servicing to be done at the front. The enclosure slide-and-tilt mechanism allows the chassis to be extended and tilted at various angles. Operation of this mechanism is given in detail in paragraph 2-4. To allow  $45^\circ$  indexing when the chassis is fully extended, the keyer unit must be at least 12 inches above the mounting surface deck or floor. There must be at least 24 inches in front of the unit to permit full extension of the chassis, and a clearance of at least 12 inches above the unit for chassis indexing. At least two inches is required at the chassis rear to provide space for external cable connections.

d. TEMPERATURE AND VENTILATION. - The keyer dissipates heat at a rate of approximately 2 Btu per minute. The use of solid state circuits, combined with the heat conduction and dissipation ability of the chassis and panel structures, limit the keyer temperature rise to  $15^\circ\text{C}$  above the ambient temperature at the location. The normal operating temperature range of the keyer is from  $0^\circ\text{C}$  ( $32^\circ\text{F}$ ) to  $+57^\circ\text{C}$  ( $+135^\circ\text{F}$ ).

e. INTERACTION WITH OTHER EQUIPMENT. - A principal feature of the keyer is its ability to operate in an environment close to other facilities. Internal shielding and effective filtering reduce the possibility of interaction with other communication equipment.

f. OPERATION WITH AUXILIARY EQUIPMENT. - Installation planning should consider the relative locations of auxiliary equipment to be used with the keyer, in addition to the aforementioned exciter and local control units. The source and routing of auxiliary, dc control, monitoring, rf output, and primary power cables, etc., should be considered during the planning stage.

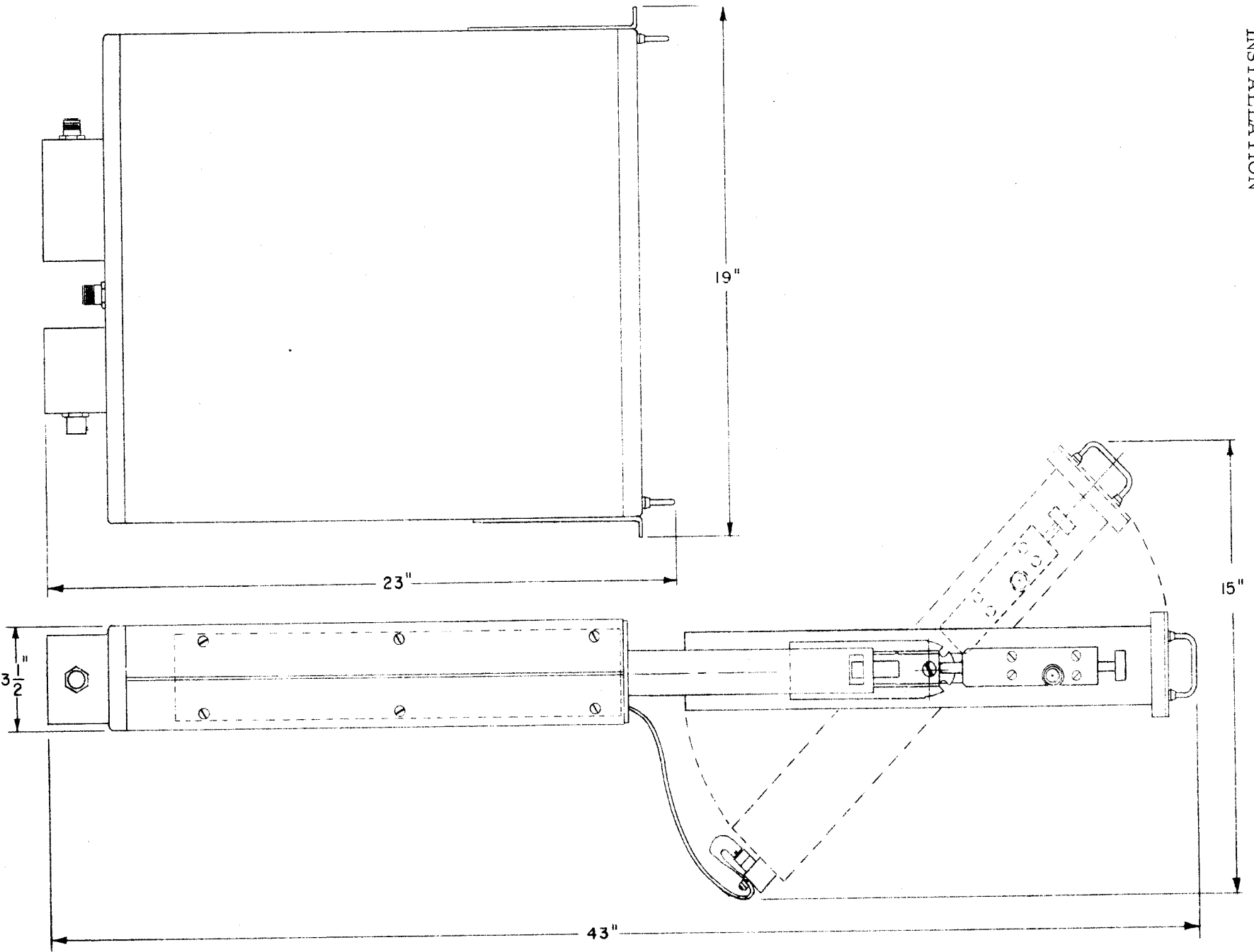

Figure 2-1. Keyer, Frequency Shift KY-655/FRT, Outline Drawing

#### 2-4. INSTALLATION REQUIREMENTS.

Installation of the keyer consists of securing the chassis enclosure to the standard relay rack or cabinet and completing the necessary external cable connections. Because the keyer is shipped assembled, the chassis assembly must be removed from its outer enclosure prior to rack installation. The empty enclosure is then installed on the rack and the chassis assembly reinserted.

a. REMOVING AND REPLACING THE DRAWER. - The following procedures describe the steps for removing and replacing the chassis assembly (drawer) in the enclosure.

(1) REMOVING THE DRAWER.

(a) Loosen the panel captive screws and open the drawer to its fully extended position.

(b) Reach in and disconnect the retractable cable at connector A6J2 at the chassis rear.

(c) Press the rear latches on both slide mechanisms and pull the drawer forward, supporting it when it separates from the slides.

(2) REPLACING THE DRAWER.

(a) Engage the drawer slides and push in until the drawer locks in the fully extended position.

(b) Connect the retractable cable at connector A6J2.

(c) Press the forward latches at both slides and close the drawer. Tighten the panel captive screws to secure the drawer in the enclosure.

b. RACK OR CABINET INSTALLATION. - The keyer enclosure contains side flanges for mounting in a standard rack or cabinet. Prior to installation, remove the chassis assembly from the enclosure following the procedure described in paragraph a(1) above.

(1) Place the empty keyer enclosure in position and secure using 1/2-inch, 10-32, fillister-head machine screws and washers.

(2) Install the assembly in the enclosure following instructions given in paragraph a(2) above.

c. OPENING, INDEXING, AND CLOSING THE DRAWER. - The following procedure describes steps to be performed for opening, indexing, and closing the drawer.

(1) To open the drawer, loosen the panel captive screws and pull the drawer out on its slides. It will lock in a fully extended position.

(2) To index the drawer on its horizontal axis, pull the levers forward on both sides simultaneously. Rotate the drawer and release the two levers to lock the drawer at the desired position.

(3) To close the drawer, index it to its horizontal position. Press the forward latches on both slides simultaneously. Close the drawer and secure with the panel captive screws.

d. EXTERNAL CABLES. - Three external cables are required for connection to receptacle on the rear filter panel of the keyer enclosure (figure 2-2). Two of these cables are not supplied with the keyer because of variations in installation requirements. Mating



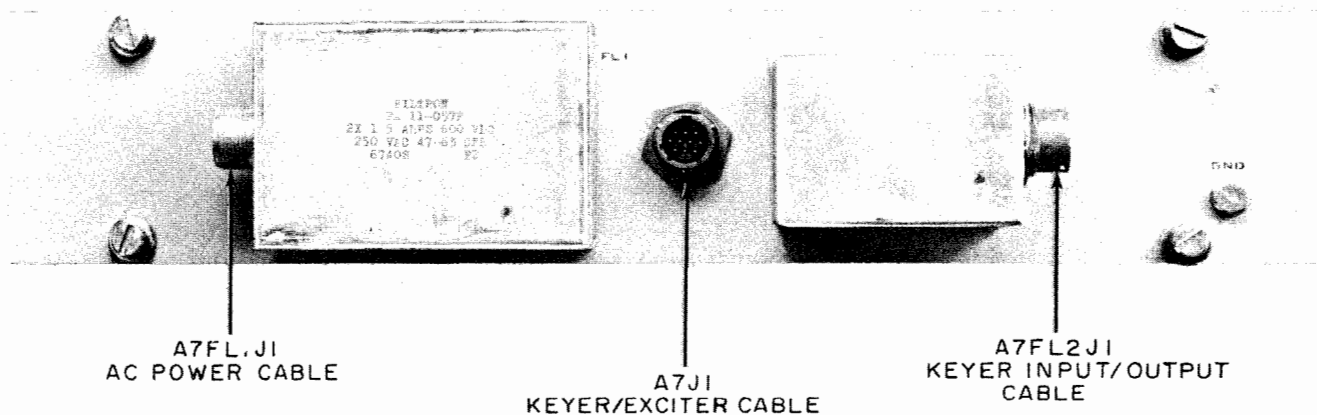

Figure 2-2. Location of External Cable Connections to Keyer

connectors are furnished for the two external cables and instructions for assembly of these cables are contained in table 2-1. The third external cable is for interconnection with Modulator-Synthesizer MD-777/FRT and is supplied with the keyer. The following paragraphs contain information relative to cable assembly and connections to the keyer. Detailed instructions for cable assembly are contained in NAVSHIPS 900,171, Chapters 5 and 6.

(1) CABLE ASSEMBLY. - Figure 2-3 shows the method of assembling the ac primary power cable and figure 2-4, the keyer input cable.

(2) CONNECTION TO KEYER. - Figure 2-2 shows the location of all external connections at the rear of the keyer enclosure. If rear access is limited at the relay rack or cabinet, the external cables can be connected just prior to installation of the enclosure. Otherwise, make all cable connections following the enclosure installation.

(3) COMPLETING CABLE CONNECTIONS. - To complete external cabling at the keyer unit, the following connections are to be made:

(a) Connect cable assembly W1 from Modulator-Synthesizer MD-777/FRT to the keyer output receptacle A7J1.

(b) Connect the keyer input cable from connector A7FL2J1 to the signal source at the installation site.

(c) Connect the ac power cable from connector A7FL1J1 to the primary power source at the installation site (paragraph 2-2a).

TABLE 2-1. CONNECTORS SUPPLIED AND EXTERNAL CABLE REQUIREMENTS

CIRCUIT WHERE USED	TYPE CABLE	EQUIPMENT RECEPTACLE	CABLE CONNECTOR
Primary power, 115/230 volt ac, 50/60 cycles, single phase, A7FL1J1	THFA, or equivalent	Sealtron, 001-14S-7P-7S	MS3108R14S-7S
Keyer input/output A7FL2J1		MS3114F14-15PW	MS3116F14-15SW

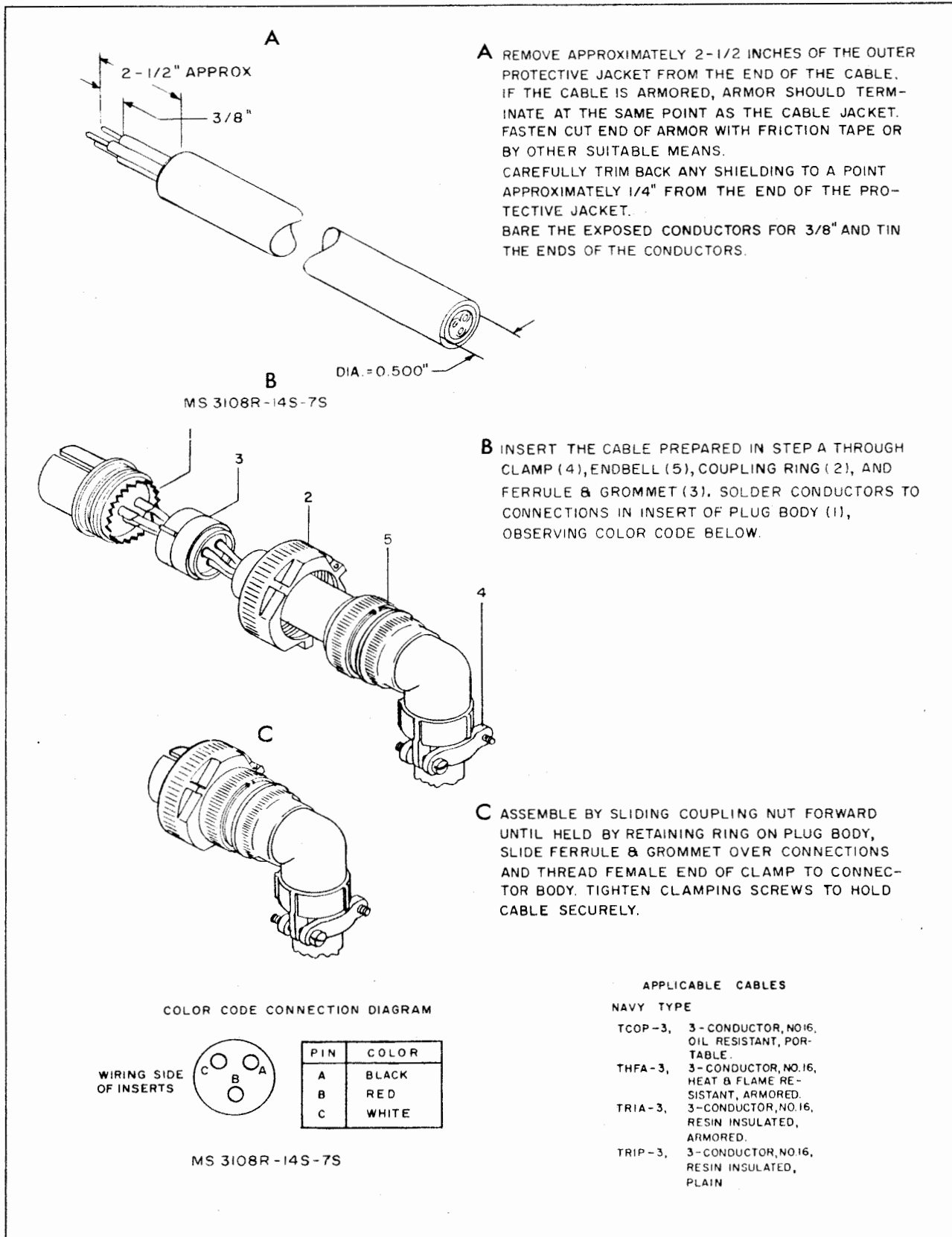

Figure 2-3. Primary Power Cable, Assembly Procedure

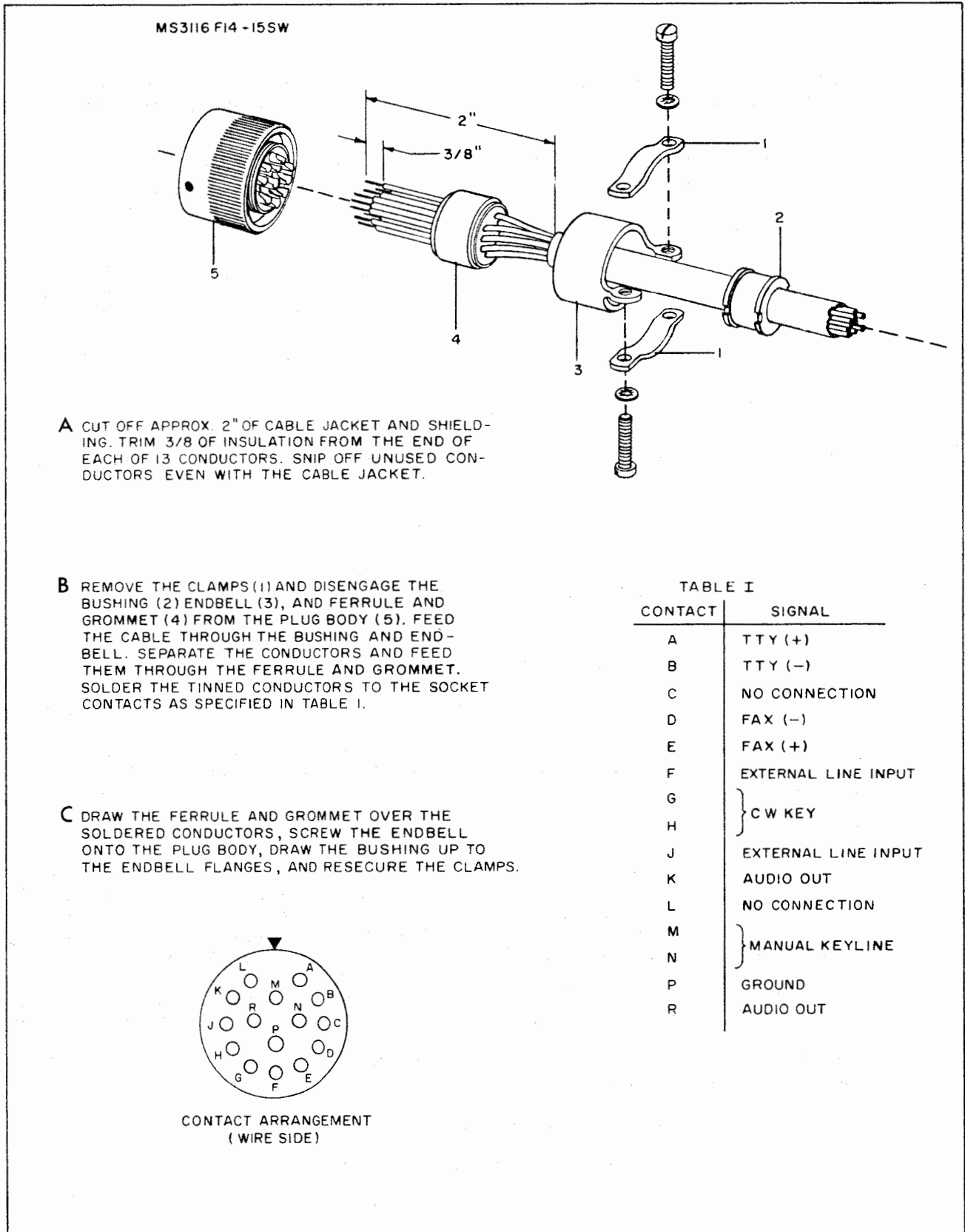

Figure 2-4. Data Cable, Assembly Procedure

## 2-5. INITIAL OPERATING TESTS.

a. GENERAL. - Following installation of the keyer and prior to making performance tests, initial operating tests are performed to assure optimum keyer performance. Operational aspects and features of the keyer are checked with particular attention to any conditions noted which could lead to abnormal performance.

b. INITIALLY ENERGIZING KEYER. - The location of each operating control is shown in figure 3-1. Table 3-1 gives a brief description of the control functions and indicates their preset positions. To energize the transmitter initially, perform the following steps in the order presented:

(1) To permit the keyer to operate as an independent unit, strap TB1-1 to TB1-2 and TB1-3 to TB1-4. This enables the keyer to be energized locally by its panel controls. Refer to the notes on figure 5-23, sheet 2 for variations in the connections to TB1 and TB2.

(2) Strap TB2-1 to TB2-2 only. This allows the keyline relay to be operated by the transition detector.

(3) Make sure that all external cable connections are secure.

(4) Verify that the keyer is connected to the correct primary power source described in paragraph 2-2a.

### CAUTION

Make sure the 115V/230 vac toggle switch (figure 3-1) is in the position which corresponds with the primary power source voltage.

(5) Place external primary power switches ON at installation site.

(6) Set RESET/TRIPPED switch to RESET. STANDBY pushbutton will light.

(7) Check the dc supply voltages by setting the CIRCUIT TEST switch to the +10, -10, +18, and -18 positions. CIRCUIT TEST meter M1 readings should be in the "green" segment.

(8) Allow the keyer to warm up for 6 hours.

c. SELECTION OF OPTIONAL CENTER FREQUENCY. - Keyer, Frequency Shift KY-655/FRT provides an optional, or fourth, center frequency output when the CTR FREQ (CPS) control is in the optional position. This output may be selected from any frequency within the range of 400 to 3000 cps and is determined at the installation site. Refer to paragraph 5-2e for detailed instructions on selecting the optional center frequency output.

d. FUNCTION TEST. - The FUNCTION TEST switch provides a means of checking the keyer outputs in the three keying modes while the unit is in a nonoperating condition.

(1) Connect a frequency counter H-P 5245L (or equivalent) to the OUTPUT MONITOR jack on the front panel.

(2) Preset all operating controls according to table 3-1.

(3) Press the OPERATE pushbutton. The button will light.

(4) Set the CTR FREQ (CPS) switch to each position. Observe that the frequency counter reading corresponds with the switch setting. Adjust FREQ ADJUST control on front panel if necessary.

(5) Set the MODE switch to CW and FUNCTION TEST to CW. The frequency counter reads 1000 cps (or 2000 cps if optional CW frequency selected per paragraph 5-2f).

(6) Set the FUNCTION TEST switch to OPERATE. The frequency counter reads 0 cps.

(7) Set the CTR FREQ (CPS) switch to 1900, MODE to TTY NORM, TTY DEVIATION CPS to 999, and FUNCTION TEST to TTY MK. Observe a frequency counter reading of 1400 cps  $\pm$ 11 cps.

(8) Set the FUNCTION TEST switch to TTY SP. The frequency counter reads 2400 cps  $\pm$ 11 cps.

(9) Set the MODE switch to TTY REV and the FUNCTION TEST to TTY MK. The frequency counter reads 2400 cps  $\pm$ 11 cps.

(10) Set the FUNCTION TEST switch to TTY SP. The frequency counter reads 1400 cps  $\pm$ 11 cps.

(11) Set the TTY DEVIATION CPS control to 000, CTR FREQ (CPS) to 2000, MODE to FAX NORM, and FUNCTION TEST to FAX WHT. The frequency counter reads 1600 cps  $\pm$ 9 cps.

(12) Set the FUNCTION TEST switch to FAX BLK. The frequency counter reads 2400 cps  $\pm$ 9 cps.

(13) Set the MODE switch to FAX REV and FUNCTION TEST to FAX WHT. The frequency counter reads 2400 cps  $\pm$ 9 cps.

(14) Set the FUNCTION TEST switch to FAX BLK. The frequency counter reads 1600 cps  $\pm$ 9 cps.

e. SELECTION OF TTY INPUT. - Various TTY transmitters will have different output loop currents or voltages. The keyer can accommodate these different TTY transmitter outputs by means of selecting a matching input loop within the keyer.

(1) Set the TTY INPUT SELECTOR on the keyer subpanel (figure 3-1) to the appropriate position (60 MA, 20 MA, 100V, 50V, POLAR, or DRY CONT) for the type of TTY transmitter used.

(2) Connect the TTY transmitter which is to be used at the installation site to the keyer input jack A7FL2J1 (figure 2-2). Refer to the appropriate technical manual for the TTY transmitter used.

(3) Set the FUNCTION TEST switch to OPERATE and the CIRCUIT TEST switch to TTY. The CIRCUIT TEST meter will read in the green segment when the TTY transmitter is transmitting.

f. OUTPUT LEVEL ADJUSTMENT. - The keyer output level must be adjusted to suit the requirements of the installation site.

(1) Terminate the keyer output with a 600-ohm load across A7FL2J1 (figure 2-2), pins K and R.

(2) Connect an audio level meter (H-P 403A or equivalent) across the 600-ohm load.

(3) Set the FUNCTION TEST switch to OPERATE and energize the TTY transmitter; ground A7 J1-E (to switch from EXT LINE to keyer output).

(4) Set the DELAY switch (figure 3-1) to MAX and adjust the LEVEL control for the required output level as measured on the audio level meter. (An output level of 0 dbm may be obtained by setting the CIRCUIT TEST switch to OUTPUT and adjusting the LEVEL control until the CIRCUIT TEST meter reads in the green segment.

g. SETTING DELAY TIME OF TRANSITION RELAY. - Prior to keyer operation in the system, the delay or "release" time of the transition detection relay must be set to suit the requirements of the installation site.

- (1) Terminate the keyer output with a 600-ohm load across A7FL2J1 pins K and R.
- (2) Connect an oscilloscope (Tektronix 585A with Type 82 plug-in or equivalent) across the 600-ohm load.
- (3) Set the FUNCTION TEST switch to OPERATE and energize the TTY transmitter.
- (4) Stop the TTY transmitter. Measure the time interval until the keyer output level (as monitored on the oscilloscope) goes to zero. This interval is the transition relay delay time.
- (5) Adjust the DELAY control for the required transition relay delay time. This is accomplished by repeatedly turning the FUNCTION TEST switch from OPERATE to TTY MK, and adjusting the DELAY control as required.

h. OPERATION WITH OTHER EQUIPMENT. - Keyer, Frequency Shift KY-655/FRT is intended for operation with Modulator-Synthesizer MD-777/FRT and Decoder-Encoder KY-656/FRT. Final tests should be performed using the keyer as a part of this system before turning equipment over to operating personnel.

Note

Before installing the keyer as part of the system, the straps on TB1 which enabled the keyer to be energized locally must be removed and the straps for remote power operation replaced. See paragraph 2-5b.

## 2-6. PREPARATION FOR RESHIPMENT.

a. EQUIPMENT DISASSEMBLY. - The following steps form a logical sequence for keyer preparation prior to reshipment.

- (1) Place the panel circuit breaker in the TRIPPED position and removal all primary power by opening the power source switches at the installation site.
- (2) Disconnect all external cables at the rear panel.
- (3) Remove from relay rack or cabinet (reverse of procedure described in paragraph 2-4b).
- (4) Collect all re-usable mounting hardware, external cables and connectors, and the two technical manuals. Spare parts to be returned with the keyer should be inventoried and replaced in their original containers if possible. Provisions should be made for replacement of missing or defective items prior to shipment.

b. REPACKAGING. - Refer to the latest packaging specifications for the instructions and requirements for packaging and packing the keyer. Also observe the following:

- (1) Mark the box containing technical manuals "TECHNICAL MANUALS INSIDE".
- (2) Check that all plug-in circuit boards and modules are secure.

SECTION 3  
OPERATION

3-1. FUNCTIONAL OPERATION.

Keyer, Frequency Shift KY-655/FRT is intended for operation with Modulator-Synthesizer MD-777/FRT (exciter) and Decoder-Encoder KY-656/FRT (local control unit) to provide rf drive, modulation, and operating controls for the Power Amplifier AN/FRT-( ) in CLASS OF EMISSION A1F1F4 only. In any other CLASS OF EMISSION other than A1F1F4 a changeover relay provides an EXTERNAL LINE at the output of the keyer.

The keyer accepts signal inputs of either cw (key), tty (teletype), or fax (facsimile/analog), and provides output signals of 1000 cps (or 2000 cps for optional cw frequency) in A1 (cw) mode, and frequency-shift signals in F1 (tty) and F4 (fax) modes. The mode is selected by a 5-position front-panel switch. The frequency-shift tones are selectable about the following center frequencies by means of a 4-position, front-panel switch:

- a. 1900 cps.
- b. 2000 cps.
- c. 2550 cps.
- d. 400-3000 cps; frequency to be selected at the installation site.

The amount of frequency deviation about the selected center frequency in the F1 (tty) mode is determined by a front-panel vernier control.

The keyer is also a transition detector in the A1 or F1 keying modes. It incorporates a relay which cycles the exciter to an "off-the-air" condition when either an F1 keyed input or an A1 "key-up" condition is sustained for a period longer than a predetermined delay time, thus preventing unwanted transmissions. The delay time is manually adjustable by the operator to suit requirements of operating conditions.

In addition, test circuits are incorporated, operable by front-panel controls, for measuring dc supply voltages and monitoring keyer outputs in the three keying modes while the keyer is in a nonoperating condition.

All operating functions of the keyer are performed using front-panel controls. When in system operation, the keyer can only be switched from "standby" to "operate" and from "operate" to "standby" modes by either the exciter or the Control Indicator, Transmitter C-7709/FRT (remote control unit). The keyer operates from a primary power source of 115/230 volts ac, 50/60 cycles, single phase. The power requirement for "standby" operation is 28 watts and for normal operation, 30 watts.

3-2. OPERATING PROCEDURES.

a. DESCRIPTION OF CONTROLS. - All controls for keyer operation are located on the front panel with seldom used controls available on a subpanel, which is exposed when the drawer is opened. Figure 3-1 shows the location of all controls, and table 3-1 supplies a functional description of each control. In addition, table 3-1 provides the "preset" control

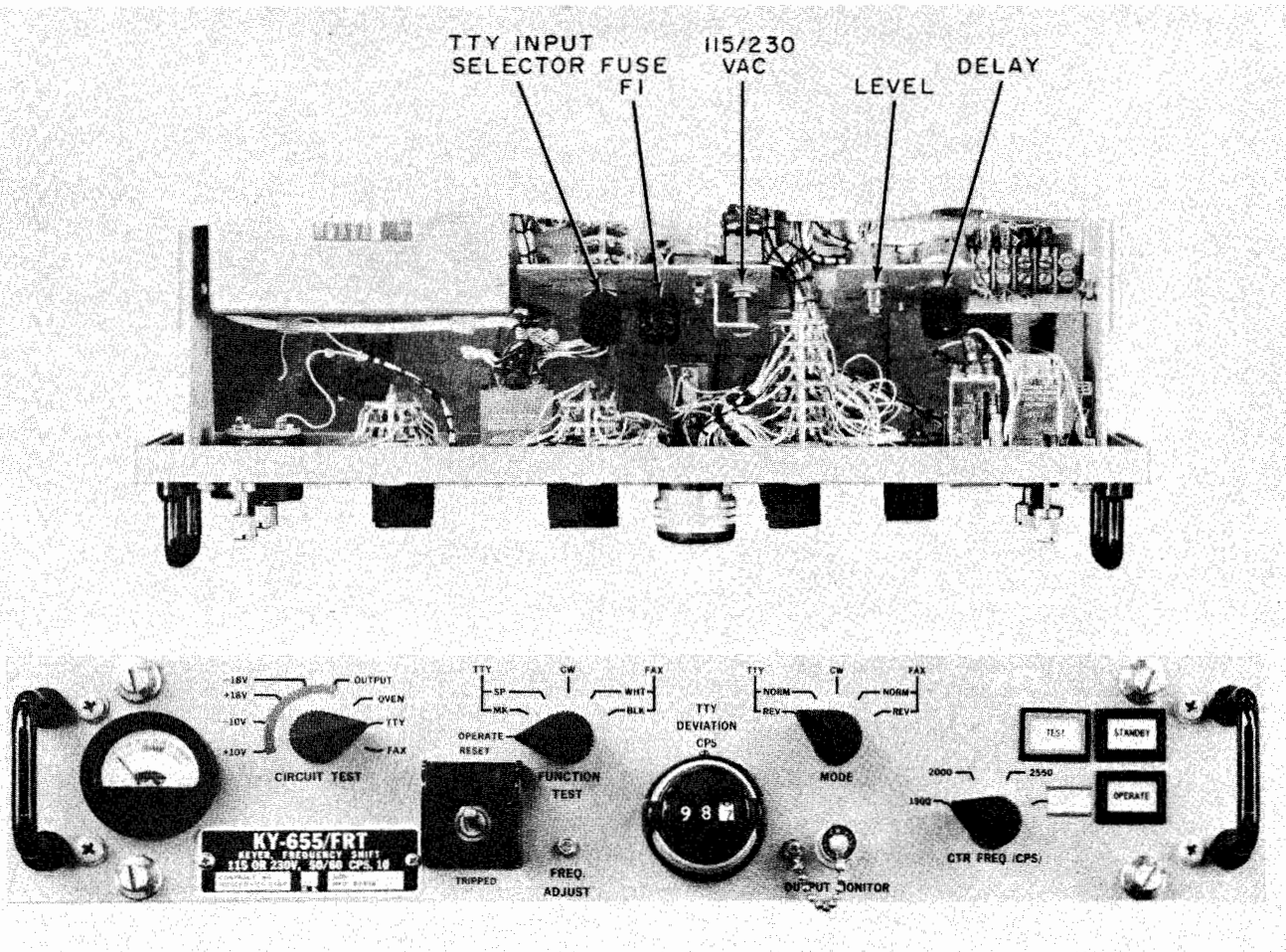

Figure 3-1. Frequency Shift Keyer KY-655/FRT,  
Location of Controls and Indicators

positions to be used for the initial performance tests contained in Section 2, and for the alignment and adjustment procedure in Section 5.

b. MODES OF OPERATION. - Table 3-2 lists the keyer modes of operation and their related outputs.

c. SEQUENCE OF OPERATION.

#### CAUTION

Before starting the keyer for the first time, make sure that the primary power source corresponds with the information contained in paragraph 2-2a. Verify that the 115V/230V switch on the subpanel is set in the correct position for the primary power available.

#### Note

To perform the following procedures, the keyer must be operated as a part of a complete HF ISB transmitter. Make sure that TB1 and TB2 are strapped for system operation. (Refer to figure 5-23 sheet 2 notes 1 and 2).



TABLE 3-1. OPERATING CONTROLS AND DEVICES

CONTROL NAME	PRESET POSITION	CONTROL FUNCTION
<u>FRONT PANEL</u>		
OPERATE Pushbutton	None	Illuminated pushbutton. Press to start keyer operation when keyer is not tied into over-all system; green lamp lights.
STANDBY Pushbutton	None	Illuminated pushbutton. Press to place keyer at standby when keyer is not tied into over-all system; white lamp lights.
TEST Lamp	None	Illuminated indicator. Amber lamp lights when FUNCTION TEST switch is not in OPERATE position.
CIRCUIT TEST	OUTPUT	Test meter and selector switch. Tests keyer at selected circuit points for monitoring and trouble shooting.
FUNCTION TEST	OPERATE	Six-position rotary switch. Simulates the various input signals (tty, fax, cw (key)).
TTY DEVIATION CPS	N/A	Dual potentiometer. Controls the amount of deviation about the selected center frequency for the tty mode of operation.
MODE	N/A	Six-position rotary switch. Selects the desired input and output signals (tty, fax, or cw).
CTR FREQ (CPS)	N/A	Four-position rotary switch. Selects the center frequency (1900 cps, 2000 cps, 2550 cps, or optional) of the output signal.
FREQ ADJUST	N/A	Variable resistor. Adjust for FS oscillator frequency aging correction.
RESET/TRIPPED	RESET	Primary power circuit breaker. Trips to remove keyer power in event of abnormal primary current level.
<u>SUBPANEL</u>		
TTY INPUT SELECTOR	N/A	Six-position rotary switch. Matches the keyer to the type of tty input signal.
DELAY	N/A	Variable resistor. Sets the release time of transition detector relay to conform to the installation requirements.
LEVEL	N/A	Variable resistor. Sets the audio output level to conform to the installation requirements.
115V/230V	Power Source	Toggle switch. Selects keyer power supply circuit for operation from 115 or 230 volts, ac power source.

TABLE 3-2. OPERATING MODES AND OUTPUTS

MODE	OUTPUT FREQUENCIES	FREQUENCY DEVIATION					
TTY	<table style="border: none;"> <tr> <td style="border: none;">1900</td> <td rowspan="4" style="border: none; vertical-align: middle;">} Center frequencies</td> </tr> <tr> <td style="border: none;">2000</td> </tr> <tr> <td style="border: none;">2550</td> </tr> <tr> <td style="border: none;">Optional</td> </tr> </table>	1900	} Center frequencies	2000	2550	Optional	Adjustable from 0 to $\pm 500$ cps about each center frequency.
1900	} Center frequencies						
2000							
2550							
Optional							
CW	1000 cps	N/A					
FAX	<table style="border: none;"> <tr> <td style="border: none;">1900</td> <td rowspan="4" style="border: none; vertical-align: middle;">} Center frequencies</td> </tr> <tr> <td style="border: none;">2000</td> </tr> <tr> <td style="border: none;">2550</td> </tr> <tr> <td style="border: none;">Optional</td> </tr> </table>	1900	} Center frequencies	2000	2550	Optional	From +400 cps (black) to -400 cps (white) about each center frequency.
1900	} Center frequencies						
2000							
2550							
Optional							

(1) STARTING. - Place external power source switches on at the installation site. Note the keyer pushbuttons which are lighted. Allow the keyer to warm up for 6 hours.

(2) MODE SELECTION. - Keyer operating mode is selected by turning the MODE switch to the appropriate position for the desired type of input.

(a) TTY MODE.

1. Set the MODE switch to TTY NORM (TTY REV position may be used in the event that a reversal of the standard fsk output is desired).

2. Select the desired output center frequency by turning the CTR FREQ (CPS) switch to the appropriate position. Next to the optional output frequency position on the CTR FREQ (CPS) control, a "window" is provided for inserting a label which has the optional frequency marked on it.

3. Turn the TTY DEVIATION CPS vernier control to the required deviation.

(b) CW MODE.

1. Set the MODE switch to CW.

(c) FAX MODE.

1. Set the MODE switch to FAX NORM (FAX REV position may be used in the event that a reversal of the standard facsimile output is required).

2. Select the desired output center frequency by turning the CTR FREQ (CPS) switch to the appropriate position.

3. Select CLASS OF EMISSION A1F1F4 (see NAVSHIPS 0967-292-9030).

(3) STOPPING. - To stop the keyer, press the STANDBY pushbutton located on the exciter or remote control unit front panel.

CAUTION

Do not use the RESET/TRIPPED circuit breaker as a keyer on/off switch. To do so, removes power from the frequency shift oscillator oven and will affect calibration to the output frequencies.

(4) AFTER USE. - During a "standby" condition between periods of actual operation, the following steps are suggested as good operating practice:

(a) Log any abnormal performance noted during operation.

(b) Perform maintenance checks for the keyer unit as described in Maintenance Standards Book NAVSHIPS 0967-293-4010.

d. INDICATOR PRESENTATIONS. - The front panel test meter and CIRCUIT TEST switch are used for checking keyer operation at selected circuit points. These tests include a measurement of the various dc power supply voltages, measurement of the frequency shift oscillator oven voltage, and a measurement of the audio output level when the keyer is operating. In addition, when the switch is in the TTY or FAX position, the meter indicates whether TTY or FAX inputs are being keyed or are left in either the mark or space condition.

To indicate acceptable meter readings for most measurements, a central section of the meter scale is colored green. Those CIRCUIT TEST switch positions using this colored section are identified by a green band on the panel. Switch positions which are not marked with the green band, represent measurements which provide informative readings outside of the green scale section. Table 3-3 lists the selector switch positions, identifies the keyer circuit to be checked, and gives the required meter reading for acceptance.

TABLE 3-3. CIRCUIT TEST MEASUREMENTS

SWITCH POSITION	CIRCUIT TESTED	METER READING REQUIRED
+10V	+10 dc power supply	Within green scale section.
-10V	-10 dc power supply	Within green scale section.
+18V	+18 dc power supply	Within green scale section.
-18V	-18 dc power supply	Within green scale section.
OUTPUT	Audio output	Within green scale section (for audio output level of approximately 0 dbm).
OVEN	+28 dc oven supply	Varies between zero level and full scale depending on ambient temperature.
TTY		Within green scale section when input is keyed; at zero level when input is in space condition; full scale when input is in mark condition.
FAX		10% when input is in black condition; full scale when input is in white condition.

e. NONOPERATING CONTROLS. - The following controls are intended for use by technicians in adjusting and calibrating the keyer and should be adjusted by a qualified technician only; figure 3-1 shows control locations.

(1) FUNCTION TEST. - A six-position selector switch, used during initial performance tests only, to check the keyer outputs while the keyer is in operation independent of other system units.

(2) FREQ ADJ. - A potentiometer adjustment for calibrating the keyer output frequency.

(3) 115V/230 VAC. - A toggle switch for selecting keyer operation from either a 115-volt or 230-volt ac primary power source.

(4) TTY INPUT SELECTOR. - A six-position selector switch used to match the keyer tty input circuit with various teletype output loop currents and voltages.

(5) DELAY. - A potentiometer adjustment for setting the transition relay delay or "release" time.

(6) LEVEL. - A potentiometer adjustment for setting the keyer audio output level.

### 3-3. SUMMARY OF OPERATION.

A summary of the procedures for keyer operation in proper sequence is given in table 3-4. These instructions include the procedures for starting and stopping the keyer, mode selection, selection of output center frequency, and setting the amount of tty deviation required.

### 3-4. EMERGENCY OPERATION.

The circuit characteristics of the keyer are such that, in the event of keyer unit failure, no emergency procedure by the operator is effective.

TABLE 3-4. KEYER, FREQUENCY SHIFT KY-655/FRT,  
SUMMARY OF OPERATION

1. TTY DEVIATION	Rotate TTY DEVIATION CPS vernier control to setting corresponding to the amount of deviation required about the selected output center frequency (tty mode only).
2. MODE SELECTION	Set MODE switch to the desired mode.
3. CENTER FREQUENCY OUTPUT	Set CTR FREQ (CPS) selector to desired output frequency (for tty and fax modes only).
4. STARTING	Select A1F1F4 CLASS OF EMISSION and put the transmitter to an "in the air" condition.
5. STOPPING	Place the transmitter on STANDBY.

### 3-5. OPERATOR'S MAINTENANCE.

a. GENERAL. - Electronic technicians are usually responsible for the maintenance and repair of transmitting equipment, although routine items of preventive maintenance which do not require elaborate test set-ups are normally assigned to the operator. Basic trouble shooting and the repair of minor defects may also be required of operating personnel from time to time. In order to meet this responsibility, the operator must have a thorough knowledge of the equipment, including a complete familiarity with the function of all controls and the procedures governing their use. A general knowledge of the circuit should be acquired so that the location of a probable cause of minor electrical or mechanical failure may be determined and corrected. Under normal conditions, however, major repairs or precise circuit adjustments should not be attempted by other than qualified technicians.

b. OPERATING CHECKS. - The keyer unit is intended for long periods of operation without requiring adjustments other than changing the operating frequency or mode. The following checks should be performed periodically by the operator as preventive maintenance steps.

(1) CIRCUIT TEST. - With the keyer unit at OPERATE, use the CIRCUIT TEST selector switch, FUNCTION TEST switch, and panel meter to check the keyer circuits for normal operation (table 3-3). Log the measurements obtained for reference and compare them with previous measurements to indicate any deviation.

(2) SYSTEM TEST. - At scheduled intervals, perform operating tests with the other transmitting system units to verify normal system operation.

c. PREVENTIVE MAINTENANCE. - A systematic, scheduled method of checking the keyer unit's performance and performing preventive maintenance is contained in the Maintenance Standards Book, NAVSHIPS 0967-293-4010.

d. EMERGENCY MAINTENANCE. - Operating personnel must expect the possibility of keyer unit failure when technician services are not immediately available. In an emergency, the need for keeping the keyer in operation is of utmost importance and the operator must be able to recognize major failure symptoms, determine the particular area of trouble, and make emergency repairs when possible. It is not practical to discuss every type of failure which may possibly occur. Instead, a general outline of trouble shooting techniques will be presented to aid the operator in developing a systematic approach to the problem.

(1) ISOLATING TROUBLE. - The keyer unit consists of a number of closely related functional circuits, contained in individual circuit modules, each performing a specific task which contributes to keyer operation. Depending on the particular circuit involved, trouble symptoms can range from a noticeable reduction in output level to a complete breakdown in the keyer. A haphazard search for trouble will not accomplish much, except by accident. A more effective approach concerns the identification of the faulty module based upon observed trouble symptoms such as abnormal measurements when using the CIRCUIT TEST switch. Make the following checks:

(a) Check that all panel controls and subpanel controls are in the intended positions and have not been moved accidentally.

(b) If the keyer unit is completely inoperative (no indication on the STANDBY or OPERATE pushbuttons), check the primary power source at the installation site for blown fuses, etc.

(c) Inspect and secure all external cable connections.

SECTION 4  
TROUBLE SHOOTING

4-1. INTRODUCTION.

This section of the technical manual contains information to enable the electronics technician to locate efficiently the cause of equipment malfunction and abnormal performance. Effective trouble shooting of electronic equipment consists of recognizing the fault symptom, identifying the circuit responsible, and isolating the defective component or module in order to repair the equipment and return it to normal operation. To perform these steps quickly and efficiently, the technician should clearly understand the purpose and operation of each functional circuit in the equipment, and follow a systematic, logical trouble shooting procedure. A haphazard search for the faulty circuit can be successful only by accident.

4-2. LOGICAL TROUBLE SHOOTING.

The following paragraphs describe a general trouble shooting technique based on six logical trouble shooting steps. If adequate field data of equipment faults is not available as a guide, a trouble shooting procedure similar to these steps should be followed.

a. SYMPTOM RECOGNITION. - This is the first step in a logical trouble shooting procedure and it requires a complete familiarity with the equipment and its operating characteristics. Some troubles, not a direct result of component failure, are only apparent as a condition of less than optimum performance. This type of trouble is usually discovered during performance of the preventive maintenance steps contained in the Maintenance Standards Book. It is well to recognize performance deterioration in addition to more apparent symptoms. More obvious troubles such as low output level or complete equipment breakdown are readily discerned.

b. SYMPTOM INVESTIGATION. - When a trouble symptom occurs and is recognized, the situation should be investigated to elaborate the symptom and further identify the trouble. Equipment controls can be adjusted and panel meter readings noted in an attempt to identify the symptom with a particular equipment function or mode of operation. For example, if keyer operation is defective for the tty mode of operation and normal in the cw and fax modes, the trouble can be associated with that circuit section employed for the tty mode.

c. PROBABLE FAULTY SECTION. - The next step in a logical trouble shooting procedure is to make a tentative decision, based on results of the symptom investigation, as to the most likely circuit section at fault. The decision should be based upon the trouble symptom and a knowledge of the equipment circuits, and be limited to those circuit sections, which if defective, could probably cause the trouble. The block diagrams, together with the functional descriptions of these diagrams, should be referred to when deciding the possible faulty circuit section. For example, using the fault symptom described in the previous paragraph, a number of tentative decisions can be made:

- (1) The trouble can be caused by a faulty MODE switch or switch circuit, but--
- (2) the frequency shift oscillator and audio amplifier circuits are not faulty because other modes of operation are normal, therefore--

(3) the trouble is caused by a faulty MODE switch or circuit supplying the defective mode signals only.

d. LOCALIZING THE FAULTY CIRCUIT. - To localize the trouble to a particular circuit section, tests should be made in an order which requires the least testing time. The test sequence should be based on validating the tentative decisions in the order of the test difficulty. If the first circuit tested is not at fault, the next circuit must be tested, and so on, until the faulty section is located. Refer to the functional circuit descriptions, service block diagrams, and test data for the particular circuit being tested. Perform tests and checks which will either eliminate or pinpoint the circuit under examination. For example, using the previously discussed fault symptom, the following test sequence and procedures could be employed:

(1) Examine the MODE switch contacts and check the circuit in question using an ohmmeter.

(2) If the MODE switch is not defective, check for presence of signal supplied from the teletypewriter output.

(3) If a normal input signal is being supplied, check the associated input circuits (tty selector module, TTY INPUT SELECTOR switch, etc.).

e. ISOLATING THE FAULTY COMPONENT. - When the faulty circuit section or module has been identified, the trouble should be pinpointed to the particular parts at fault. For example, using the previously discussed fault symptom, the following procedure could be followed to isolate the faulty component:

(1) Continuity at suspected MODE switch circuits can be established by circuit tests.

(2) If a normal input signal is being supplied from the teletypewriter, trace the signal to the tty selector and the keyer and transition relay modules.

(3) Check the tty selector and the keyer and transition relay modules by measuring at suitable test points to isolate the faulty component or components.

f. FAULT ANALYSIS. - When the faulty component has been isolated by circuit tests and measurements, review the tentative decisions and the trouble shooting procedure employed to establish the reason for component failure. Make sure that the defective component is the actual cause of trouble and not just the result of an undiscovered malfunction, perhaps in another circuit. For example, a short-circuited capacitor in a power supply decoupling circuit can cause a resistor, located in another module, to overheat and burn out. A fault analysis of this trouble would consider the following aspects when establishing the reason for the component failure. Otherwise, a replacement of the burned-out resistor would not only fail to solve the problem, but result in another burned-out resistor:

(1) Only an abnormally high current flow could have caused the resistor to overheat and burn out.

(2) Current flow of this magnitude could only occur if a short circuit existed at the load terminal and not the supply terminal of the resistor.

(3) Circuit measurements at the resistor would verify this analysis and lead to the discovery of the short-circuited decoupling capacitor.

#### 4-3. OVER-ALL FUNCTIONAL DESCRIPTION.

a. GENERAL. - The keyer, figure 4-1, accepts inputs of cw (key), tty, or fax/analog signals at speeds up to 400 bauds. For cw on-off keying, the keyer generates a 1000-cycle tone on key down. For tty and fax keying, the keyer generates frequency shift tones about

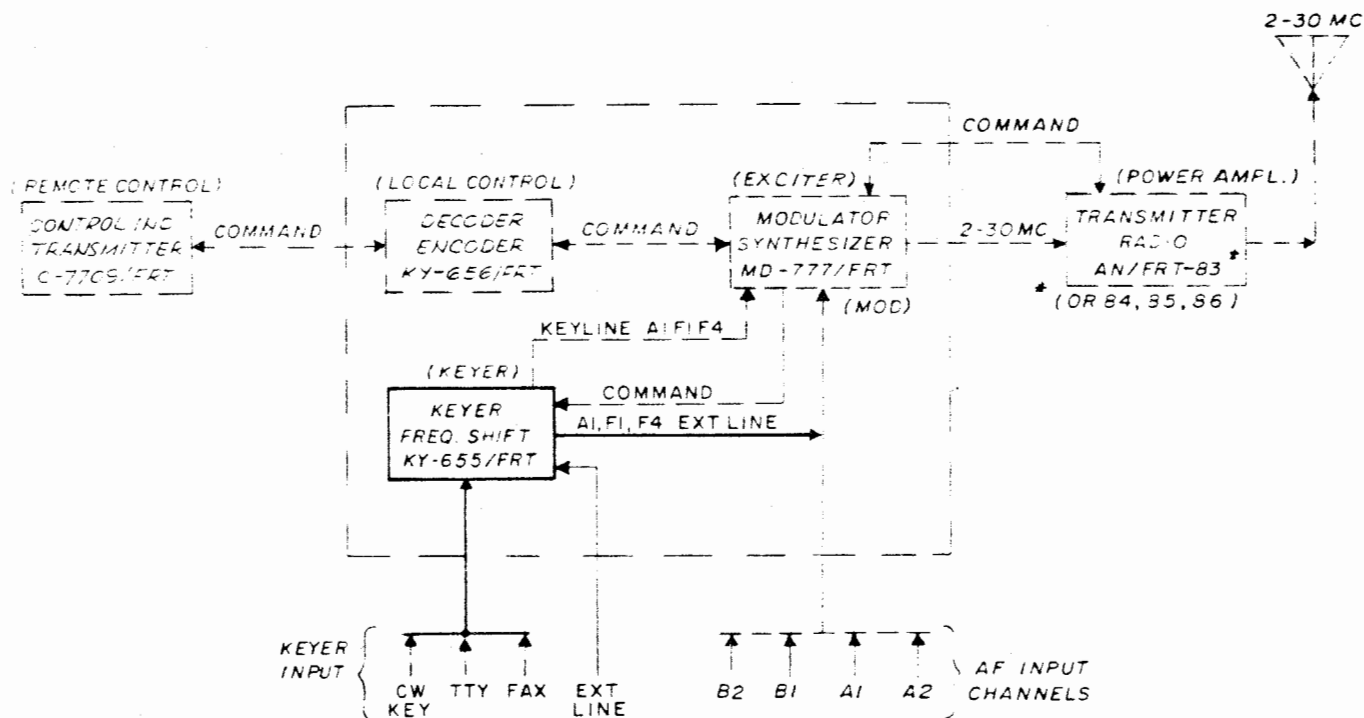

Figure 4-1. System Basic Block Diagram

four center frequencies which are selectable. The selectable center frequencies are: 2550 cycles, 2000 cycles, 1900 cycles, and an optional frequency (400 cps to 3000 cps). The type of signal to be received and the audio output to be generated are selected from front panel controls. The keyer output provides audio modulation for the exciter which in turn provides modulation for the transmitter in the A1F1F4 CLASS OF EMISSION.

All keyer operating functions are performed using front-panel controls. However, standby-operate conditions of the keyer are controlled either locally (from the exciter location) or remotely (remote control unit). Refer to the functional block and servicing block diagrams and schematics provided, as required for a complete understanding of the circuit under discussion.

b. FUNCTIONAL BLOCK DIAGRAM. - Figure 4-2 is a functional block diagram of the keyer which indicates the main signal path through the unit. The keyer input which may be cw (key), tty, or fax is selected at the front panel MODE switch. For cw on-off keying, a 1000-cycle tone is generated. For tty and fax, frequency-shift tones are generated. After the type signal is selected and the correct tone is generated, the output signal is applied to the exciter. The routing of each type input through the keyer is described in the following paragraphs.

(1) TTY INPUT. - The tty input which may be 20 ma neutral, 60 ma neutral, 50 volts neutral, 100 volts neutral, dry contact, or polar is routed from the MODE switch to the tty selector assembly (A1). The signal is coupled through one of several resistors, as determined by the TTY INPUT SELECTOR switch, which matches the keyer input to the type of input signal. From the tty selector, the tty signal is coupled to the keyer and transition relay assembly (A2).

The tty signal triggers the electronic keyer which in turn shifts the FS oscillator (A3) frequency. In addition, the electronic keyer triggers the transition detector, which enables the keyline and cycles the transmitter to an on-the-air condition.



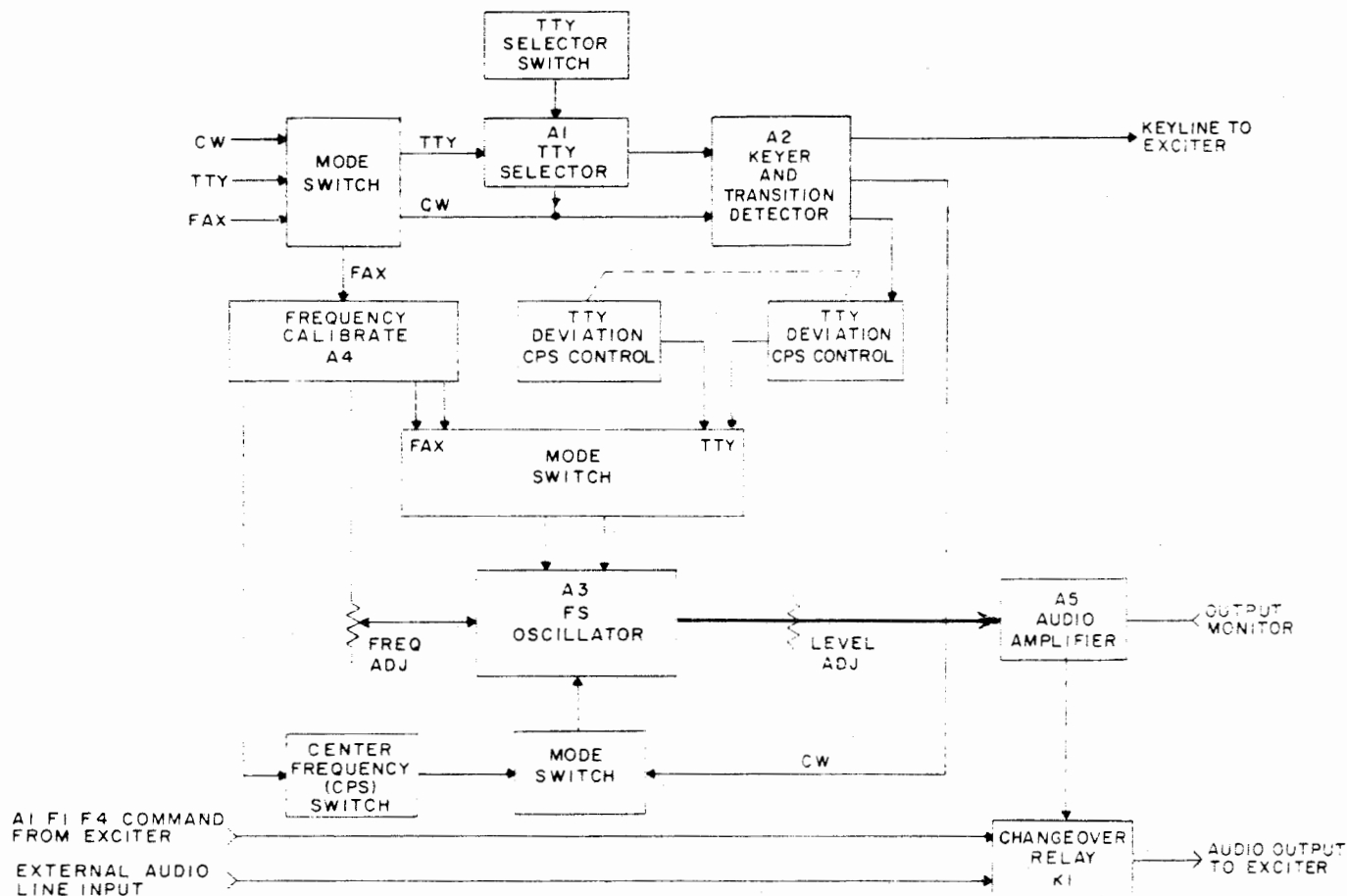

Figure 4-2. Keyer, Functional Block Diagram

Within the FS oscillator assembly, a frequency-shift signal is developed. In the tty mode, the frequency of the signal is determined by the setting of the four-position CTR FREQ (CPS) switch, the TTY DEVIATION CPS control, and the input signal condition. The TTY DEVIATION CPS control sets the frequency plus and minus one-half the dial reading about the selected center frequency, as the input changes from space to mark. The output from the oscillator is coupled through the LEVEL adjust, which controls the audio level to the audio amplifier assembly (A5) and then via the changeover relay K1 to the exciter. The audio output can be monitored at the front panel OUTPUT MONITOR jack.

(2) CW INPUT. - The cw input is routed from the MODE switch to the tty selector assembly (A1) and then to the keyer and transition relay assembly (A2). The signal triggers the electronic keyer which in turn triggers the FS oscillator (A3). In addition, the electronic keyer triggers the transition detector, which cycles the transmitter to an on-the-air condition.

Within the FS oscillator assembly, a 1000-cycle tone is developed for cw "on-off" keying (2000-cycle tone if optional cw frequency selected). The output from the oscillator for cw is coupled to the audio amplifier and then via the changeover relay K1 to the exciter.

(3) FAX INPUT. - The fax input is routed from the MODE switch to the frequency calibration board (A4), and coupled through a potentiometer to the FS oscillator assembly.

Within the FS oscillator assembly, a frequency-shift tone is developed. The frequency of the tone is determined by the setting of the CTR FREQ (CPS) switch and the facsimile/analog input level. The frequency-shift tone varies linearly from +400 cps (for a +1-volt input) to -400 cps (for a +10-volt input) about the center frequency selected. The output from the oscillator is coupled to the audio amplifier assembly (A5) and then via the change-over relay K1 to the exciter.

4-4. TTY SELECTOR (A1). (See figure 4-3.)

a. DESCRIPTION. - The tty selector module is a printed circuit board that contains several resistor networks which provide variations in the input impedance as required to receive the various teletype input signals, and to level shift all neutral signals to polar signals. The appropriate network is selected by the TTY INPUT SELECTOR switch S6, mounted on the chassis subpanel. The 60 ma, 20 ma, 100 volt, and 50 volt teletype input signals are applied to pins 1, 2, 3, and 4, respectively (figure 5-17). For the dry contact position of TTY INPUT SELECTOR switch and per cw key input, the input signal is applied across resistor R4. For the polar position of the TTY INPUT SELECTOR switch, the teletype input is applied directly to the keyer and transition relay board A2. The output from each resistor network is coupled by way of the TTY INPUT SELECTOR switch, to the keyer and transition relay board (A2). Variable resistor R20 is used to align the selector board as described in paragraph 5-2d(6).

b. PRELIMINARY CHECK. - Before beginning trouble shooting, de-energize the equipment and make a preliminary check of the following:

(1) Seating of the module connector.

(2) Component connections (loose or cold solder joints, etc.)

c. TEST EQUIPMENT. - Electronic Multimeter AN/USM-116.

d. CONTROL SETTINGS. - Not applicable.

e. TEST DATA. (See figure 5-17.) - No external test points are provided on the tty selector module (A1). Trouble shooting is performed by measuring the resistance of the various resistors.

4-5. KEYER AND TRANSITION RELAY (A2). (See figure 4-3.)

a. DESCRIPTION. - The keyer and transition relay module is a printed circuit board that contains an amplifier limiter circuit and a signal transition detector circuit. The amplifier provides amplification for cw (key) and teletype input signals; the transition detector detects an input signal change from high to low or from low to high and initiates a keyline closure to the transmitter by way of the exciter. These two circuits are described in the following paragraphs; refer to figures 4-4 and 5-18 as required.

(1) AMPLIFIER CIRCUIT. - The amplifier consists of transistors Q2, Q4, Q6, Q8, Q10, and Q1. The input signal is applied to the gate circuit of Q2 through A2P1-13. Diodes CR1 and CR3, in the gate circuit of Q2, protect the transistor against damage from excessive input voltages. Transistor Q2 is a source follower which has a high input impedance and a low output impedance, which provides an impedance match between the input signal and amplifier Q4. R14 is adjusted for side stability. (The adjustment of R14 is described in paragraph 5-2d(4).) Amplifier Q4 raises the level of the input signal to a level usable to drive the Schmitt trigger. The Schmitt trigger, which consists of Q6 and Q8, reshapes the input waveform. The output from Q8 is applied to the base of Q1 by way of A2P1-16, the MODE switch S1, and A2P1-14. When the MODE switch is in the TTY REV position, the output of Q8 is inverted by Q10 before being applied to the base of Q1. Transistor Q1 functions as a switch; a high output representing a "mark" and a low output represents a "space". The output from Q1 is used to shift the frequency of the FS oscillator module (A3). For the tty mode, the output of Q1 is adjusted by resistor R5; for the cw mode,

the output of Q1 is adjusted by resistor R8. (The adjustment of R8 and R5 is described in paragraph 5-2d(4).) The output of Q1 is also applied to the signal transition detector circuit.

(2) SIGNAL TRANSITION DETECTOR CIRCUIT. - The signal transition detector circuit is used to energize and de-energize relay K1 which provides a keyline open or closed condition to the transmitter. When a signal is received, the keyline closes, and the transmitter cycles to an on-the-air condition. When there is a sustained signal, the keyline opens, and the transmitter cycles to an off-the-air condition. Transitions in the input signal are detected in the base circuit of Q3. When the output of Q1 goes from high to low or from low to high, L1 rings and the positive excursions of the ringing turns on Q3. With Q3 conducting, Q5, which functions as a switch, is off, and a positive voltage pulse is coupled through CR6 to turn on Q12 and subsequently energize relay K1. A positive voltage pulse is also applied via C3 which triggers Q7, discharging C5. (The output from A2P1-11 is applied to A2P1-6 by way of the MODE switch and the FUNCTION TEST switch.) When there is a sustained mark or space, Q7 turns off when the available current from C5 and R27 drops below the minimum holding current. With Q7 turned off, capacitor C5 is charged through R27 and the DELAY adjustment R7 located on the subpanel. When the charge on capacitor C5 reaches the firing voltage, Q7 conducts and a positive voltage pulse is coupled through R41 to turn on Q11 and de-energize relay K1. The contacts (5 and 8) of relay K1 provide a keyline closure to the exciter in A1F1F4 class of emission; K1 contacts 7 and 9 are in series with the audio output of the keyer.

Switch Q13 is connected to the output of Q10 in the cw mode by way of the MODE switch. When a cw key down signal is received, Q13 turns on which holds Q12 in conduction and subsequently overrides the reset pulse from timing circuit Q2. Transistor Q13 is used to defeat the automatic opening of relay K1 in a sustained key down condition.

b. PRELIMINARY CHECK. - Before beginning trouble shooting, de-energize the equipment and make a preliminary check of the following:

- (1) Seating of the module connector.
- (2) Component connections (loose or cold solder joints, etc.).

c. TEST EQUIPMENT. - None.

d. CONTROL SETTINGS. - Rotate the FUNCTION TEST and CIRCUIT TEST switches as required. Place the MODE switch in the TTY NORM position.

e. TEST DATA. (See figure 5-18.) - No external test points are available on module A2. Trouble shooting is performed by rotating the CIRCUIT TEST switch to the TTY position and observing the meter deflection.

4-6. FS OSCILLATOR (A3). (See figure 4-3.)

a. DESCRIPTION. - The FS oscillator module consists of an oven, and two printed circuit boards which contain two crystal-controlled Colpitts-type oscillator circuits, a mixer circuit, and regulated voltage circuits. The output from the module is an audio frequency which is the difference between the two oscillator frequencies. The crystals used are matched for frequency shift with temperature and aging drift; refer to figures 4-5 and 5-19 as required.

The operating frequency of oscillator Q2 is dependent on the capacitance of varactor CR6. The voltage applied to varactor CR6 is determined by the input to pin A1-5. For all modes of operation except cw, the input to A1-5 is applied from the CTR FREQ (CPS) switch. For the cw mode, the input to A1-5 is applied from the keyer and transition relay module (A2). The voltage from A1-5 is applied to R4 which is a preset sensitivity control that compensates for tolerance variations in varactors and crystals. When an increase in voltage is coupled from R4 to varactor CR6, the capacitance of CR6 increases and

subsequently the frequency of the oscillator decreases. If the voltage applied to CR6 decreases the frequency of the oscillator increases. The output of the oscillator is coupled through emitter follower Q4 and amplified by Q6. Diodes CR7 and CR8 at the output of Q6, limit the input level to mixer Z1 in order to keep the output level constant and minimize distortion. L13 filters the limited signal.

The operating frequency of oscillator Q1 is dependent on the capacitance of varactors CR5 and CR4. The voltage applied to CR5 is determined by the setting of the front panel FREQ ADJUST control A6R9. Varactor CR5 and A6R9 compensate for oscillator aging. The voltage applied to CR4 is determined by the output of Q1 on board A2. Resistor R5 on board A2 is a preset sensitivity control which compensates for tolerance variations in crystals and varactors. Transistor A2Q1 and its associated components provide compensation for the nonlinear frequency/voltage characteristics of the oscillator. Because of the compensating circuit, the oscillator frequency can be made to vary linearly with input voltage. The input to the base of Q1 is determined by the front-panel MODE switch S1-G. The inputs to A2-3 and A2-4 are summed at the junction of A2R2 and A2R1 and the diode-resistor network. For tty, the input is applied to A2-3 and A2-4 from the TTY DEVIATION CPS control; for cw, the inputs at A2-3 and A2-4 are a fixed bias, and for fax, the inputs at A2-3 and A2-4 come via the fax calibration portion of the frequency calibration assembly (A4). For increases at the input to A2Q1, the frequency of oscillator A1Q1 decreases, and for decreases at the input the frequency of the oscillator increases. The output of A1Q1 is coupled through emitter follower A1Q3, amplified and limited by Q5, and applied to mixer Z1.

The output of the mixer is the difference frequency between the two oscillator frequencies as established by the mode of operation. For the tty mode, the output is variable from 0 to 500 cps above to 0 to 500 cps below one of the following frequencies: 1900 cps, 2000 cps, 2550 cps, and an optional frequency. For the cw mode, the output is a 1000 cps for "key down" condition and 0 cps for "key-up". For the fax mode, the output is continuously variable from 400 cps below to 400 cps above one of the following frequencies: 1900 cps, 2000 cps, 2550 cps, and an optional frequency. Coil L14 and C34 at the output of Z1 form an rf filter so that only the af signals are coupled to the audio amplifier assembly (A5). The output level is 25 mv rms  $\pm 2$  db.

Zener diodes CR1 and CR2 provide voltages of +6 vdc and +12 vdc, respectively. The +6 vdc is used on oscillator card A3A2 and, together with the +12 vdc, is used for bias on the frequency calibration assembly A4.

b. PRELIMINARY CHECK. - Before beginning trouble shooting, turn the power off and make a preliminary check of the following:

- (1) Seating of the chassis harness plug.
- (2) Component connections (loose or cold solder joints, etc.).

c. TEST EQUIPMENT. - Not applicable.

d. CONTROL SETTINGS. - Not applicable.

e. TEST DATA. (See figure 5-19.) - No external test points are provided on the FS oscillator (A3). Therefore, trouble shooting is performed by repeating the test data for initial operating tests (paragraphs 2-5d and 2-5f). Satisfactory completion of these tests assures normal performance of card A3 (see paragraph 4-8).

4-7. FREQUENCY CALIBRATION (A4). (See figure 4-3.)

a. DESCRIPTION. - The frequency calibration module (A4) is a printed circuit board that contains several resistor networks. Each network provides a voltage which is used to vary the frequency of the FS oscillator (A3). The inputs to the calibration module, with the exception of fax input, are dc voltages (+18 vdc and +12 vdc). For the fax mode of operation,

the fax inputs (varying dc voltage) are coupled by way of the front-panel MODE switch to terminals 13 and 14 of the calibration module. The outputs from the module are applied, by way of the MODE switch, to the FS oscillator module (A3). The outputs, which are adjustable, are used within the oscillator module to vary the operating frequency. The output adjustments (variable resistors R9, R11 through R17, and R21) are described in paragraph 5-2d(3).

b. PRELIMINARY CHECK. - Before beginning trouble shooting, de-energize the equipment and make a preliminary check of the following:

- (1) Seating of the module connector.
- (2) Component connections (loose or cold solder joints, etc.).

c. TEST EQUIPMENT. - Electronic Multimeter AN/USM-116.

d. TEST DATA. (See figure 5-20.) - No external test points are provided on the frequency calibration module (A4). Trouble shooting is performed by measuring the resistance of the various resistors.

4-8. AUDIO AMPLIFIER (A5). (See figure 4-3.)

a. DESCRIPTION. - The audio amplifier module is a printed circuit board that contains five amplifier stages and a meter detector stage. This module amplifies the audio output of the FS oscillator module (A3) to a level suitable for modulating the exciter, and provides a buffered monitor output and a metering output. Refer to figures 4-6 and 5-21 as required.

The output from the FS oscillator module is applied to the base of the first amplifier Q2 by way of A5P1-4. Amplifier Q2 has a voltage gain of 12 db. The output of Q2 is coupled to Q3, which has a voltage gain of 12 db. The output of Q3 is coupled to the input of the final amplifier (Q1) through XA5-2, the MODE switch A6S1E-1, 2, 4, and 5, and the contacts of relay K1 in the keyer and transition relay module (A2). When the MODE switch is in the CW position (A6S1E-3), the output of Q3 is amplified by Q5, which has a voltage gain of 12 db, before being applied to the final amplifier Q1. (A high-pass filter in the input of Q5, consisting of R20 and C9, attenuates the repetition frequency developed by cw on-off keying. R16 sets the level to compensate for filter loss.) The output of Q3 is also coupled through emitter follower Q6 and subsequently applied to the OUTPUT MONITOR jack via the FUNCTION TEST switch A6S2G. The final amplifier Q1 has a voltage gain of 6 db. The output of Q1 is coupled through matching transformer T1 to the output (XA5-8, 10) and subsequently to the exciter. The output of Q1 is also coupled through detector Q4 to the CIRCUIT TEST switch for monitoring purposes.

b. PRELIMINARY CHECK. - Before beginning trouble shooting, de-energize the equipment and make a preliminary check of the following:

- (1) Seating of the module connector.
- (2) Component connections (loose or cold solder joints, etc.).

c. TEST EQUIPMENT. - Not applicable.

d. CONTROL SETTINGS. - Rotate the CIRCUIT TEST and FUNCTION TEST switches as required. Place the MODE switch in the TTY NORM position.

e. TEST DATA. (See figure 5-21.) - No external test points are provided on the audio amplifier module (A5). Trouble shooting is performed by rotating the CIRCUIT TEST switch to the OUTPUT position and repeating the test data for initial operating tests (paragraph 2-5f).

4-9. POWER SUPPLY (PS1). (See figure 4-3.)

a. DESCRIPTION. - The power supply assembly, which consists of four subassemblies, provides the dc voltages required for operation of the Frequency Shift Keyer KY-655/FRT. Subassembly A1 consists of three relays which switch +18 vdc, ground, and a contact closure. Subassemblies A2 and A3 consist of four regulator circuits which develop +18 vdc with floating return, regulated +10 vdc and -10 vdc with floating returns, and +18 vdc with a grounded return. Subassembly A4 contains rectifier circuits. The operation of these circuits is described in the following paragraphs. A +28-volt oven supply is also contained in the power supply. Refer to figures 4-7 and 5-22 as required.

(1) RELAY SUBASSEMBLY (A1). - The relay subassembly contains three relays, K1, K2, and K3. When ac power is applied to the power supply, relay K3 is energized (+28 vdc applied from rectifier CR1/CR2) and contacts A3 and A2 open. If the power is removed from the power supply, K3 is de-energized and contacts A2 and A3 close, which provides a system fault indication. Relays K1 and K2 close when an operate command is generated either locally or remotely (Modulator-Synthesizer MD-777/FRT). When K1 and K2 are energized, a ground is applied to the front panel OPERATE indicator through K2 contacts B2 and B1, and +18 vdc is applied to the keyer and transition relay module (A2) through K2 contacts A1 and A2. In local power control a ground is coupled from the front panel STANDBY switch through K1 contacts B1 and B2 to hold the relays energized, and +18 vdc is coupled to the audio amplifier (A5) through K1 contacts A1 and A2. When K1 and K2 are de-energized, a ground is applied to the front panel STANDBY indicator through K2 contacts B2 and B3, and there are open circuits through B2 and B3, and A2 and A3.

(2) REGULATOR ASSEMBLIES (A2 AND A3). - The regulator assemblies contain four series regulator circuits. The regulated voltages developed are +18 vdc with grounded return, +18 vdc with floating return, and  $\pm 10$  vdc with floating return. The operation of each circuit is identical except for the voltage developed; therefore, the +18 volt regulator is the only circuit described. The circuit consists of series regulator PS1Q3 (mounted on the power supply chassis), control amplifier Q1, and differential amplifier Q3 and Q5. A sample of the +18 volt output is developed at the arm of resistor R16. The sample voltage is compared with a fixed reference voltage (+6 vdc) developed by Zener diode CR2 in the differential amplifier stage Q3 and Q5. The output at the collector of Q3 drives the base of Q1 which controls the conductance of series regulator PS1Q3. When the sampled output voltage exceeds the reference voltage, the differential amplifier output drives Q1 further into conduction and subsequently decreases the conduction of PS1Q3. When the sample voltage is less than the reference voltage, the voltage drop across Q1 is increased which increases the conduction of PS1Q3 and subsequently raises the output voltage. The conductance of series regulator PS1Q3 is controlled to maintain a constant +18 volt output. Zener diode CR1 in the emitter of Q1 establishes a constant bias, while diodes CR3 and CR5 provide temperature compensation.

(3) RECTIFIER SUBASSEMBLY (A4). - The rectifier assembly consists of four full-wave rectifier and filter circuits. The voltage developed at terminals 11 and 12 (rectifiers CR1/CR2 and CR3/CR4) is approximately +21 vdc. The voltage developed at terminals 13 and 14 (rectifiers CR5/CR6 and CR7/CR8) is approximately 30 vdc.

b. PRELIMINARY CHECK. - Before beginning trouble shooting, de-energize the equipment and make a preliminary check of the following:

- (1) Seating of the keyer chassis plug.
- (2) Component connections (loose or cold solder joints, etc.).

c. TEST EQUIPMENT. - Electronic Multimeter AN/USM-116.

d. CONTROL SETTINGS. - Not applicable.

e. TEST DATA. (See figure 5-22.) - No external test points are provided on the power supply assembly PS1. Trouble shooting is performed by measuring the output voltages.

#### 4-10. SERVICE BLOCK DIAGRAMS.

Figures 4-4 thru 4-7 are service block diagrams for the keyer unit modules. These illustrations provide maintenance technician with a pictorial guide for use in trouble shooting. Main signal flow is represented by heavyweight lines, and lightweight lines are used for secondary path. Arrowheads, placed on the flow lines, indicate the direction of signal flow. Waveforms, where applicable, are placed at appropriate test points on the service block diagrams.

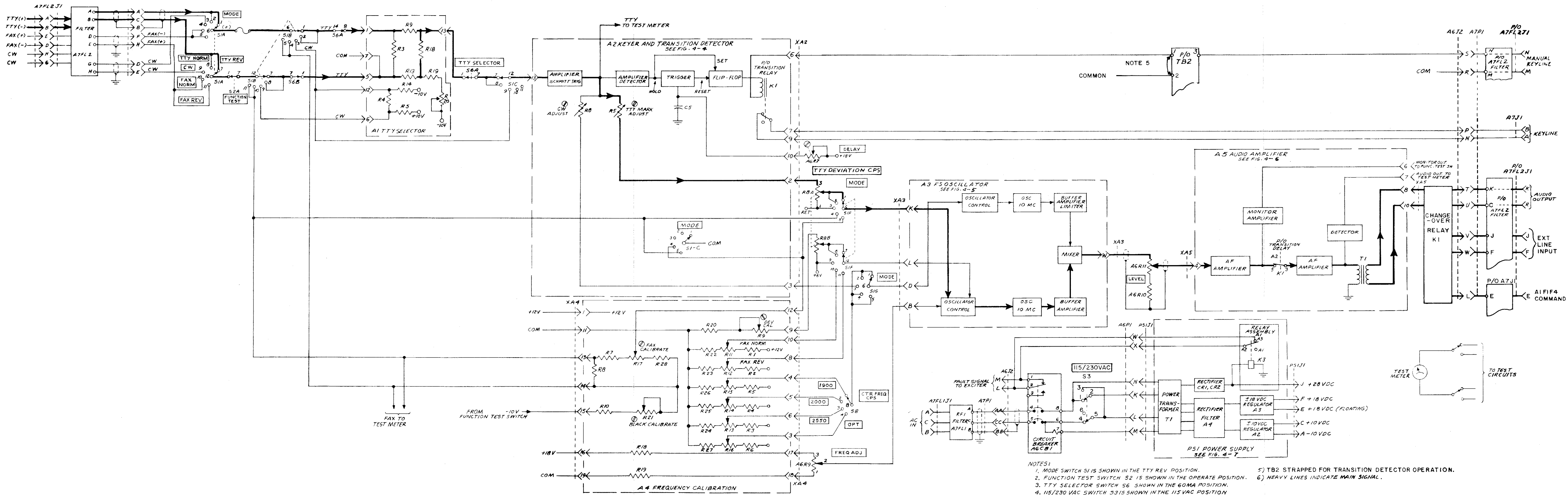

- NOTES:
1. MODE SWITCH S1 IS SHOWN IN THE TTY REV POSITION.
  2. FUNCTION TEST SWITCH S2 IS SHOWN IN THE OPERATE POSITION.
  3. TTY SELECTOR SWITCH S6 IS SHOWN IN THE 60MA POSITION.
  4. 115/230 VAC SWITCH S3 IS SHOWN IN THE 115 VAC POSITION.
  5. TB2 STRAPPED FOR TRANSITION DETECTOR OPERATION.
  6. HEAVY LINES INDICATE MAIN SIGNAL.



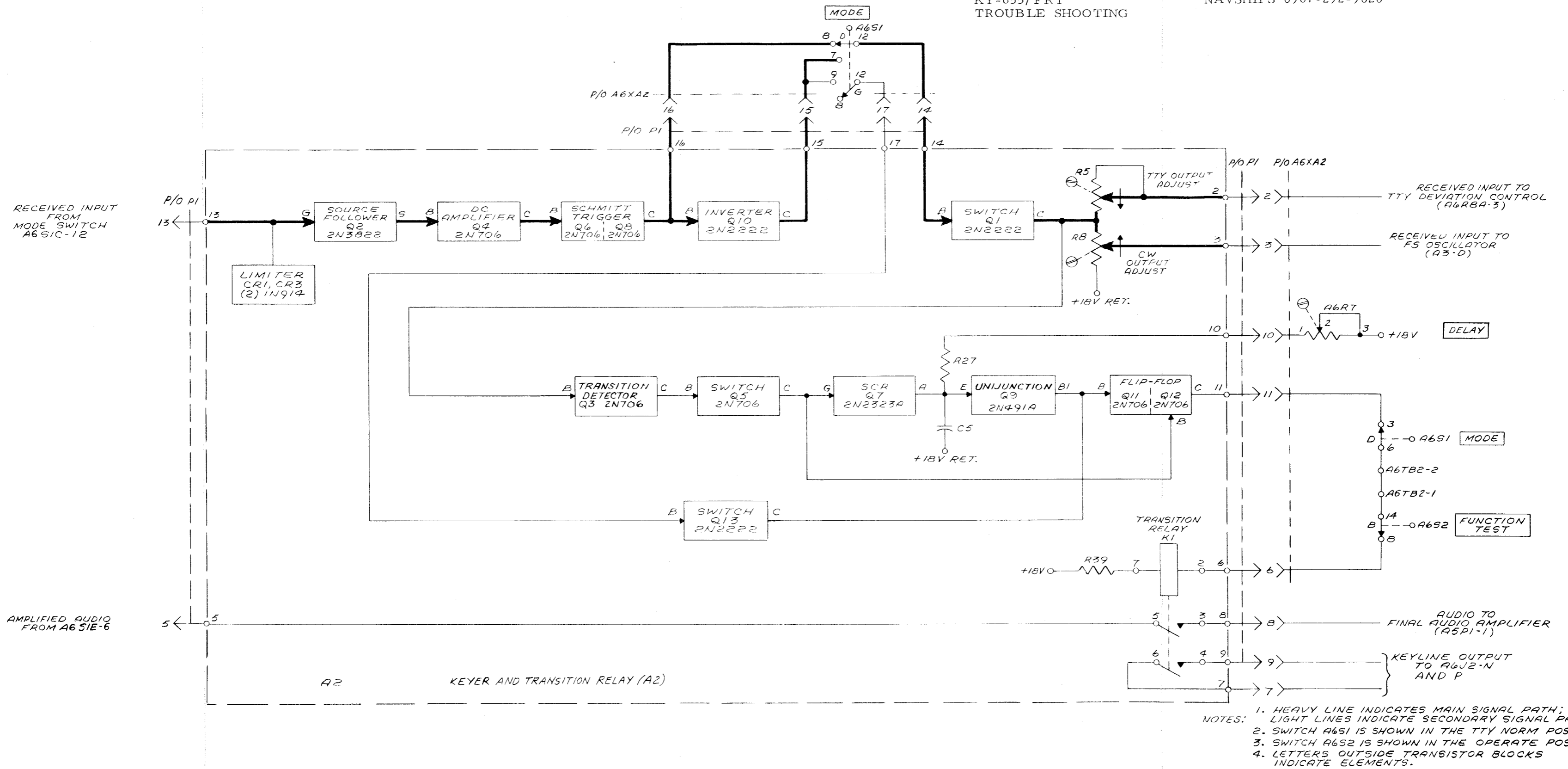

Figure 4-4. Keyer and Transition Relay Assembly (A2), Service Block Diagram

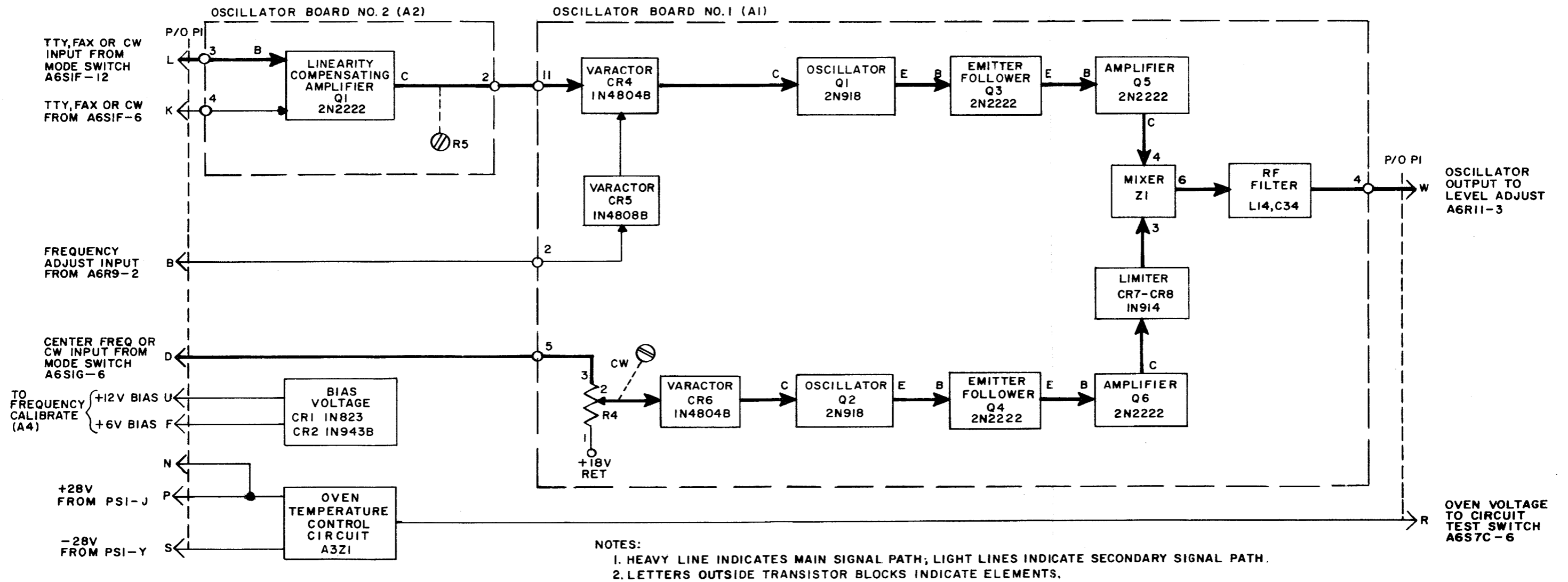
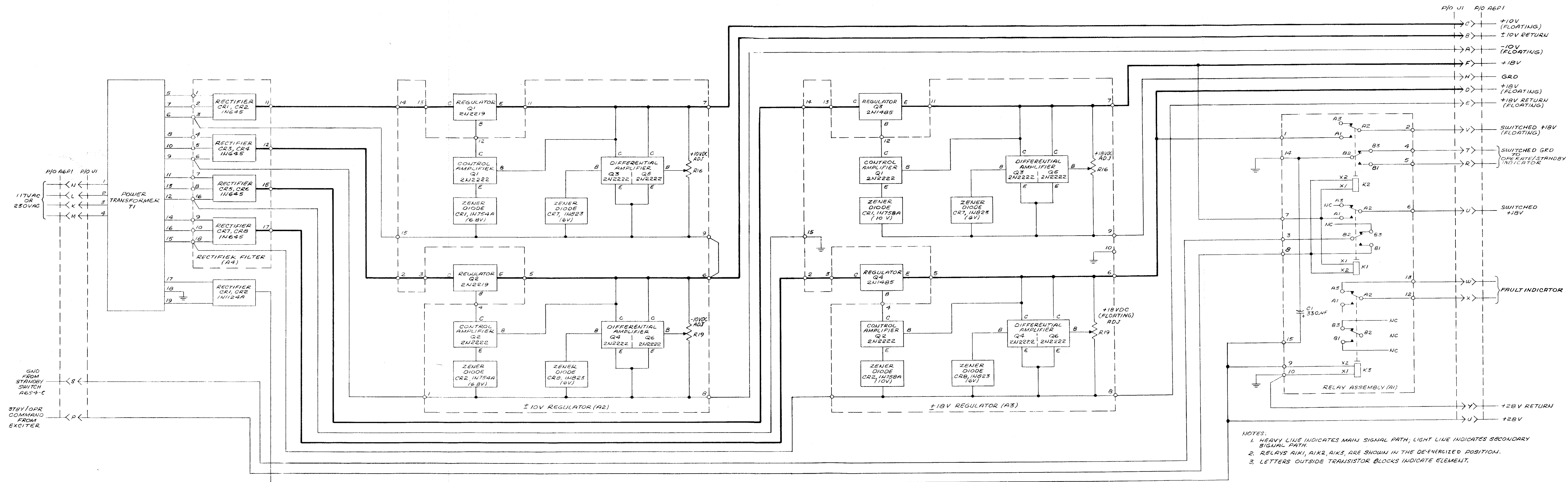

Figure 4-5. FS Oscillator Assembly (A3),  
Service Block Diagram





NOTES:  
1. HEAVY LINE INDICATES MAIN SIGNAL PATH; LIGHT LINE INDICATES SECONDARY SIGNAL PATH.  
2. RELAYS A1K1, A1K2, A1K3, ARE SHOWN IN THE DE-ENERGIZED POSITION.  
3. LETTERS OUTSIDE TRANSISTOR BLOCKS INDICATE ELEMENT.

Figure 4-7. Power Supply Assembly (PS1),  
Service Block Diagram

SECTION 5  
 MAINTENANCE

5-1. INTRODUCTION.

This section provides removal, replacement, repair and alignment procedures on a unit-by-unit basis for thorough and efficient maintenance of the modular subassemblies in the Keyer, Frequency Shift KY-655/FRT. Refer to the Maintenance Standards Book (NAVSHIPS 0967-293-4010) for complete preventive maintenance and reference standards procedures.

Note

The Naval Electronic Systems Command no longer requires the submission of failure reports for all equipments. Failure reports and performance and operational reports are to be accomplished for designated equipments (refer to Electronics Installation and Maintenance Book, NAVSHIPS 0967-000-0000) only to the extent required by existing directives. All failures shall be reported for those equipments requiring the use of failure reports.

5-2. TUNING AND ADJUSTMENT.

a. GENERAL. - The following paragraphs contain information on tuning and adjustment procedures required to insure performance capabilities expected of the keyer. Coverage includes test equipment, control settings, procedures, and instructions for selecting the optional output center frequency.

b. TEST EQUIPMENT. - Table 5-1 lists all test equipment required for tuning and adjustment procedures:

TABLE 5-1. TEST EQUIPMENT

TYPE	MODEL (OR EQUIVALENT)	APPLICATION
Differential Voltmeter	Fluke Model 883AB	AC-DC volts, ohms, measurements
Multimeter	AN/PSM-6	
Frequency Counter	AN/USM-207 (with video amplifier)	Frequency measurements
Oscilloscope	Tektronix 585A with Type 82 plug-in unit	Waveform measurements

TABLE 5-1. TEST EQUIPMENT (Cont)

TYPE	MODEL (OR EQUIVALENT)	APPLICATION
DC Power Supply	Power Designs, Inc. Model 4005	Audio test signals
Audio Signal Generator	Hewlett-Packard Model 206A	
Audio Level Meter	Hewlett-Packard Model 403A	
Shunt Resistor	Hewlett-Packard Model 11033A	

CAUTION

Always de-energize the keyer before removing or replacing modules when using the test cable. Otherwise, interrupting live circuits will damage connector terminals and may damage critical components.

c. PRELIMINARY CONTROL SETTINGS. - Table 5-2 lists keyer preliminary control settings. Some of these settings will vary during performance of the tuning and adjustment procedures; refer to figures 3-1 and 5-1 for controls and connector information as required.

TABLE 5-2. PRELIMINARY CONTROL SETTINGS

CONTROL	SETTING
OPERATE	ON (green light)
STANDBY	OFF (no light)
CIRCUIT TEST	OUTPUT
FUNCTION TEST	OPERATE
TTY DEVIATION CPS	000
MODE	TTY NORM
CTR FREQ (CPS)	N/A
FREQ ADJUST	N/A
RESET/TRIPPED	RESET
TTY INPUT SELECTOR	N/A
DELAY	N/A
LEVEL	N/A
115V/230V	As Required

d. TUNING AND ADJUSTMENT PROCEDURES.

(1) INTRODUCTION. - This paragraph includes instructions for performing all tuning, alignment, and other adjustment procedures required to insure optimum keyer performance. The keyer modules (figure 5-1) will be aligned first and in the order specified below. After aligning and installing the modules, perform the final keyer tests and adjustments provided in paragraph 5-2d(8).

- (a) Power supply (PS1).
- (b) Frequency calibration (A4).
- (c) Keyer and transition relay (A2).
- (d) Audio amplifier (A5).
- (e) TTY selector (A1).
- (f) Frequency shift oscillator (A3).

Note

Before any frequency adjustment or alignment is performed, a warm-up period of at least six hours must be observed to enable the oscillator to stabilize.

(2) POWER SUPPLY (PS1). (See figure 5-9.)

(a) TEST EQUIPMENT. - To adjust the power supply module, the following test equipment (table 5-1) is required:

1. AC/DC differential voltmeter.

(b) INSTRUCTIONS. - To adjust the power supply module output voltages:

1. Select the positive scale on the voltmeter.
2. Connect the voltmeter common lead to tty selector board (A1) terminal P1-5, and the positive lead to A1 terminal P1-9, figure 5-2.
3. Adjust PS1A2R16 to read +10 vdc on the voltmeter.
4. Select the negative scale on the voltmeter.
5. Connect the voltmeter positive lead to tty selector board (A1) terminal 8.
6. Adjust PS1A2R19 to read -10 vdc on the voltmeter.
7. Select the positive scale on the voltmeter.
8. Connect the voltmeter positive lead to keyer and transition relay board (A2) terminal P1-1, figure 5-3.
9. Adjust PS1A3R19 to read +18 vdc on the voltmeter.
10. Connect the voltmeter positive lead to audio amplifier board (A5) terminal P1-3, and the negative lead to chassis ground, figure 5-8.
11. Adjust PS1A3R16 to read +18 vdc on the voltmeter.

Note

The power supply also provides a +28 vdc output for the oven temperature control circuit in the frequency shift oscillator. However, this voltage is not adjustable.

(3) FREQUENCY CALIBRATION (A4). (See figure 5-7.)

(a) TEST EQUIPMENT. - To adjust the frequency calibration module, the following test equipment (table 5-1) is required:

1. Frequency counter, with plug-in unit.
2. DC power supply.
3. AC/DC differential voltmeter.

(b) INSTRUCTIONS. - To adjust the frequency calibration module:

1. Connect the frequency counter to the front panel OUTPUT MONITOR jack.
2. Set the CTR FREQ (CPS) switch to the position specified below and adjust the indicated resistor for the desired frequency counter readout.

<u>CTR FREQ (CPS) Setting</u>	<u>Adjustment</u>	<u>Freq. Counter Readout (CPS)</u>
OPT	A4R16	Selected Optional Frequency
1900	A4R15	1900
2000	A4R14	2000
2550	A4R13	2550

3. Set the CTR FREQ (CPS) switch to 2000, TTY DEVIATION CPS to 999, and the FUNCTION TEST to TTY SP.

4. Adjust A4R9 on the frequency calibration module for a reading of 2500 cps on the frequency counter.

5. Set the MODE switch to FAX NORM, and the CTR FREQ (CPS) switch to 2000.

6. Connect the positive output lead of the external power supply to A7FL2J1-E (figure 5-1) and the return lead to A7FL2J1-D (fax input terminals).

7. Connect the voltmeter across the power supply, and adjust the supply for an output voltage of +1 vdc  $\pm$  5 mv as measured on the voltmeter.

8. Adjust A4R11 for a reading of 2400 cps on the frequency counter.

9. Set the MODE switch to FAX REV.

10. Adjust A4R12 for a reading of 1600 cps on the frequency counter.

11. Set the MODE switch to FAX NORM.



12. Increase the power supply output voltage to +10 vdc  $\pm$ 5 mv.

13. Adjust A4R17 for a reading of 1600 cps on the frequency counter.

14. Set the MODE switch to FAX REV. If frequency counter does not read 2400 cps, repeat steps 7 through 13.

15. Set MODE switch to FAX NORM and FUNCTION TEST to FAX BLK.

16. Adjust A4R21 for a reading of 2400 cps on the frequency counter.

(4) KEYER AND TRANSITION RELAY (A2). (See figure 5-3.)

(a) TEST EQUIPMENT. - To align the keyer and transition relay module, the following test equipment (table 5-1) is required:

1. Audio signal generator.

2. Frequency counter, with plug-in unit.

(b) INSTRUCTIONS. - To align the keyer and transition relay module:

1. Set the front panel MODE switch to CW, CTR FREQ (CPS) to 2000, and FUNCTION TEST to CW.

2. Connect the frequency counter to the keyer OUTPUT MONITOR jack.

3. Adjust A2R8 for a reading of 1000 cps on the frequency counter.

4. Set the MODE switch to TTY NORM, FUNCTION TEST to TTY MK, and TTY DEVIATION CPS to 999.

5. Adjust A2R5 for a reading of 1500 cps on the frequency counter.

6. Set the FUNCTION TEST switch to OPERATE and the TTY INPUT SELECTOR switch (figure 3-1) to POLAR.

7. Connect the audio signal generator across the tty input terminals (A7FL2J1-A and A7FL2J1-B). Note that the audio signal generator output is floating off ground.

8. Set the audio signal generator frequency to 50 cps, and the output level to 500 mv rms.

9. Set the CIRCUIT TEST switch to TTY.

10. Adjust A2R14 until the CIRCUIT TEST meter reads in the green area.

11. Decrease the audio signal generator output level, readjusting A2R14 to maintain a CIRCUIT TEST meter green area reading, until A2R14 has no control. This level should be less than 100 mv rms.

(5) AUDIO AMPLIFIER (A5). (See figure 5-8.)

(a) TEST EQUIPMENT. - To align the audio amplifier module, the following test equipment (table 5-1) is required:

1. Audio level meter, with shunt resistor.

(b) INSTRUCTIONS. - To align the audio amplifier module:

1. Set the MODE switch to TTY NORM and FUNCTION TEST to OPERATE, and CENTER FREQ switch to 2000 cps.

2. Strap TB2 for manual keyline operation; see sheet 2, note 2 of figure 5-23.

3. Connect the audio level meter to audio output terminals A7FL2J1-K and R.

4. Set the front panel CIRCUIT TEST switch to OUTPUT; short together A7FL2J1 pins M and N and ground A7J1 pin E.

Note

A reading of 50 on the CIRCUIT TEST meter equals 0 dbm on audio level meter.

5. Adjust the LEVEL control on the keyer subpanel for a reading of 0 dbm on the audio level meter.

6. Set the MODE switch to CW.

7. Short together A7FL2J1-G and A7FL2J1-H (figure 5-1).

8. Adjust A5R16 for a reading of 0 dbm on the audio level meter.

9. Remove the shorts from A7FL2J1 and A7J1 and replace strap on TB2 for system operation.

(6) TTY SELECTOR (A1). (See figure 5-6.)

(a) TEST EQUIPMENT. - To align the tty selector module, the following test equipment (table 5-1) is required:

1. Multimeter.

2. DC power supply.

(b) INSTRUCTIONS. - To align the tty selector module:

1. Set the MODE switch to TTY NORM, FUNCTION TEST to OPERATE, CTR FREQ (CPS) to 2000, CIRCUIT TEST to TTY, TTY DEVIATION CPS to 600, and the TTY INPUT SELECTOR switch on the keyer subpanel to 60 ma (see figure 3-1).

2. Connect the multimeter and power supply in series with A7FL2-A (positive) and A7FL2-B (negative) (figure 5-1). Set the multimeter to read dc current in the 100 ma range.

3. Adjust the power supply output for a reading of 30 ma on the multimeter.

4. Vary the power supply output from 28 ma to 32 ma  $\pm$ 4 ma. The CIRCUIT TEST meter will read above the green area for mark, and below the green area for space.

5. Adjust A1R20 for symmetry about 30 ma.

(7) FREQUENCY SHIFT OSCILLATOR (A3). (See figure 5-4.)

(a) TEST EQUIPMENT. - To align the frequency shift oscillator module, the following test equipment (table 5-1) is required:

1. Frequency counter, with plug-in unit.
2. Oscilloscope, with plug-in unit.
3. AC/DC differential voltmeter.

(b) INSTRUCTIONS. - To align the frequency shift oscillator module:

Note

All controls with the exception of A3A1L5 are factory preset adjustments and should not be readjusted in the field. The following procedure is to be used as an initial alignment procedure, and performed only after the following conditions have been met.

1. The keyer chassis and all modules have been pretested, aligned, and allowed to warm-up at least six hours prior to adjustments.
2. The front panel FREQ ADJUST control is set fully counterclockwise and then adjusted five turns clockwise.
3. Set the MODE switch to CW, the FUNCTION TEST to OPERATE, and connect the frequency counter and oscilloscope to the OUTPUT MONITOR jack.
4. Remove the oscillator outer cover and adjust A3A1L5 for 0 cps output as observed on the oscilloscope. Replace cover immediately to maintain normal operating temperature.
5. Set the FUNCTION TEST switch to CW. Observe a reading of 1000 cps  $\pm$ 100 cps on frequency counter.
6. Set CENTER FREQ (CPS) switch to 2000, FUNCTION TEST to TTY SP, MODE to TTY NORM, and TTY DEVIATION CPS control to 000. Observe reading of 2000 cps  $\pm$ 100 cps on the frequency counter.
7. Set TTY DEVIATION CPS control to 999  $\pm$ 1 (1000). Observe reading of 2500 cps  $\pm$ 100 cps on the frequency counter.
8. Set FUNCTION TEST switch to TTY MK. Observe reading of 1500 cps  $\pm$ 100 cps on the frequency counter.

(8) FINAL KEYER ALIGNMENT.

(a) TEST EQUIPMENT. - To align the keyer, the following test equipment (table 5-1) is required:

1. Oscilloscope, with plug-in unit.
2. Frequency counter, with plug-in unit.
3. Audio level meter.
4. Shunt resistor.

TABLE 5-3. FREQUENCY CALIBRATION (A4) AND KEYER  
AND TRANSITION RELAY (A2) VOLTAGE CHECK

FRONT PANEL SETTINGS				VOLTMETER CONNECTIONS		VOLTMETER READING (+ vdc)	ADJUSTMENT
MODE	FUNCTION TEST	CTR FREQ (CPS)	TTY DEVIATION CPS	POSITIVE	NEGATIVE		
TTY NORM	TTY SP	OPT	000	A4P1-3*	A4P1-11	0 - 11V*	A4R16
TTY NORM	TTY SP	1900	000	A4P1-4	A4P1-11	9.03	A4R15
TTY NORM	TTY SP	2000	000	A4P1-5	A4P1-11	9.25	A4R14
TTY NORM	TTY SP	2550	000	A4P1-6	A4P1-11	10.35	A4R13
TTY NORM	TTY SP	N/A	000	A3J1-L	A4P1-11	6.35	N/A
TTY NORM	TTY SP	N/A	999	A3J1-L	A4P1-11	3.91	A4R9
TTY NORM	TTY MK	N/A	999	A3J1-K	A4P1-11	3.41	A2R5 <sup>Δ</sup>
CW	CW	N/A	N/A	A3J1-D	A4P1-11	6.35	A2R8

NOTE: The voltage readings given in the above table are typical readings, and will vary slightly from unit to unit. Final adjustments are always determined by final keyer alignment (paragraph 5-2d(8)).

\* Figure 5-7; <sup>Δ</sup> Figure 5-3.

NAVSHIPS 0967-292-9020

KY-655/FRT  
MAINTENANCE

5. Audio signal generator.

6. DC power supply.

(b) CONDITIONS. - The following conditions must be observed prior to performing final alignment procedures:

1. All prealigned modules have been installed, the power is applied 6 hours prior to adjustment, and the FREQ ADJUST control was set fully counterclockwise, then 5 turns clockwise.

2. The FUNCTION TEST switch is set to OPERATE, MODE to CW, CTR FREQ (CPS) to 1900, CIRCUIT TEST to TTY, and TTY DEVIATION CPS to 000.

(c) INSTRUCTIONS. - To align the keyer, perform the following steps:

1. Power Supply Adjust. Set the CIRCUIT TEST switch to the +10V, -10V, +10V, -18V, and oven positions. The CIRCUIT TEST meter should read in the green segment of the scale for each setting. If necessary, adjust per the instructions of paragraph 5-2d(2) and then set the CIRCUIT TEST switch to TTY.

2. Reference Adjust. Connect an oscilloscope to the OUTPUT MONITOR jack. If necessary, remove the cover from the FS oscillator module (A3) and adjust A3A1L5 (figure 5-4) for 0 frequency output. Replace the cover and disconnect the oscilloscope.

3. CW Adjust. Connect a frequency counter to the OUTPUT MONITOR jack. Set the FUNCTION TEST switch to CW, and adjust A2R8 (figure 5-3) for a frequency counter reading of 1000 cps.

4. Center Frequency Adjust. Set the FUNCTION TEST switch to TTY SP, the MODE switch to TTY NORM and adjust A4R15 (figure 5-7) for a frequency counter reading of 1900 cps.

a. Set the CTR FREQ (CPS) switch to 2000, and adjust A4R14 for a frequency counter reading of 2000 cps.

b. Set the CTR FREQ (CPS) switch to 2550, and adjust A4R13 for a frequency counter reading of 2550 cps.

c. Set the CTR FREQ (CPS) switch to the optional frequency position, and adjust A4R16 for a frequency counter reading of the selected optional center frequency.

5. Space Adjust. Set the CTR FREQ (CPS) switch to 2000 and the TTY DEVIATION CPS dial to 999 and adjust A4R9 (figure 5-7) for a frequency counter reading of 2500 cps.

6. Mark Adjust. Set the FUNCTION TEST switch to TTY MK and adjust A2R5 (figure 5-3) for a frequency counter reading of 1500 cps.

7. Linearity Check. Set the TTY DEVIATION CPS dial or FUNCTION TEST switch as specified below and observe the indicated frequency counter reading.

<u>Switch Setting</u>	<u>Freq. Counter Reading</u>
TTY DEVIATION CPS to 500	1750 ± 6 cps
FUNCTION TEST to TTY SP	2250 ± 6 cps
TTY DEVIATION CPS to 012	2006 ± 1 cps

<u>Switch Setting</u>	<u>Freq. Counter Reading</u>
FUNCTION TEST to TTY MK	1994 ± 1 cps
TTY DEVIATION CPS to 999	1500 ± 11 cps
FUNCTION TEST to TTY SP	2500 ± 11 cps

8. TTY NORM/REV Check. Set the CTR FREQ (CPS) switch to 2000, TTY DEVIATION CPS switch to 012, FUNCTION TEST to TTY MK, and MODE to TTY REV. The frequency counter should read 2006 ± 1 cps.

9. FAX/Analog Adjust. Set the FUNCTION TEST switch to FAX BLK and the MODE switch to FAX NORM and adjust A4R11 (figure 5-7) for a frequency counter reading of 2400 cps.

a. Set the FUNCTION TEST switch to FAX WHT and adjust A4R17 for a frequency counter reading of 1600 cps.

b. Set the FUNCTION TEST switch to FAX BLK, the MODE switch to FAX REV and adjust A4R12 for a frequency counter reading of 1600 cps.

c. Repeat procedure 9 thru step b and readjust if necessary.

d. Disconnect the frequency counter.

10. Output Level Adjust. Strap terminal board TB2 for keyline manual operation and close the keyline manual switch by shorting A7J1FL2 terminals M and N (see figure 5-23).

a. Set the MODE switch to TTY NORM, FUNCTION TEST to OPERATE, TTY DEVIATION CPS to 999, CTR FREQ (CPS) to 2000, and CIRCUIT TEST to OUTPUT. Ground A7J1 pin E.

b. Terminate the keyer output with a 600-ohm load across A7FL2J1 pins K and R and adjust the LEVEL control for a center scale reading (0 dbm) on the CIRCUIT TEST meter. Measure and record the output level across the load with an audio level meter.

c. Set the MODE switch to TTY REV. The change in output level, as recorded in step b, is less than 0.5 db.

d. Set the MODE switch to CW, close the CW input key by shorting pins G and H of A7FL2J1 and adjust A5R16 (figure 5-8) for an audio level meter reading of 0 dbm.

e. Disconnect the audio level meter, 600-ohm load, and cw input key short from A7FL2J1.

11. Side Stability Adjust. Ensure that the keyer is set up as in procedure 10 thru step a and set the CIRCUIT TEST switch to TTY.

a. Connect an audio signal generator across A7FL2J1 pins B (TTY-) and A (TTY +) and set the TTY INPUT SELECTOR switch to POLAR.

b. Set the signal generator for 50 cps at 0 dbm. If the CIRCUIT TEST meter does not read in the green segment of the scale, adjust A2R8 (figure 5-3).

c. Reduce the signal generator output, adjusting A2R8 to maintain a center scale reading on the CIRCUIT TEST meter. Stop when A2R8 has no further control over the meter reading. The level should be less than 100 mv rms.

d. Remove the keyline manual strap from TB2 and the keyline switch short from A7J1FL2.

12. TTY Inputs Adjustment. Connect a multimeter and power supply in series with A7FL2J1-A (positive) and A7FL2J1-B (negative). Set the multimeter to read dc current in the 100 ma range.

a. Set the MODE switch to TTY NORM, FUNCTION TEST to OPERATE, TTY DEVIATION CPS to 999 CTR FREQ (CPS) to 2000, and CIRCUIT TEST to TTY.

b. Check all of the TTY inputs by setting the TTY INPUT SELECTOR switch to each position and supplying the corresponding voltage or current. Observe that, as the applied voltage or current increases from zero to the specific input level, the CIRCUIT TEST meter indicates a change from space to mark (zero to full-scale deflection) at a point equal to one-half the input level  $\pm 15\%$ ,  $\pm 10\%$ .

Example: With an input level of 60 ma, the change from space to mark should occur between 31.5 and 37.5 ma.

$$60 \text{ ma} \div 2 = 30$$

$$15\% \text{ of } 30 = 4.5$$

$$10\% \text{ of } 30 = 3$$

$$30 + 4.5 \pm 3 = 31.5 \text{ to } 37.5$$

Observe also that, as the applied voltage or current decreases from the specific input level to zero, the CIRCUIT TEST meter indicates a change from mark to space at a point equal to one-half the input level  $-15\%$ ,  $\pm 10\%$ .

Example: With the same 60 ma input, the change from mark to space will occur between 28.5 and 22.5 ma.

$$30 - 4.5 \pm 3 = 28.5 \text{ to } 22.5$$

If necessary, adjust A1R20 (figure 5-2) for symmetry.

c. Disconnect the power supply and multimeter.

13. FAX/Analog Input Check. Connect a power supply and multimeter in series to A7FL2J1-E (FAX +) and A7FL2J1-D (FAX -). Connect a frequency counter to the OUTPUT MONITOR jack.

a. Set the CIRCUIT TEST switch to FAX, FUNCTION TEST to OPERATE, MODE to FAX NORM, and CTR FREQ (CPS) to 2000.

b. Set the power supply for a +1-volt output. The frequency counter should read 2400 cps  $\pm 9$  cps.

c. Set the power supply for a +10-volt output. The frequency counter should read 1600 cps  $\pm 9$  cps.

d. Disconnect the power supply and frequency counter.

e. SELECTION OF OPTIONAL CENTER FREQUENCY OUTPUT.

(1) GENERAL. - The keyer is designed to provide four output center frequencies. Three of these output center frequencies are fixed (1900 cps, 2000 cps, and 2550 cps) and the fourth may be selected at the installation site from the range of frequencies between 400 and 3000 cps. This paragraph contains instructions for selecting the optional output center frequency.

(a) TEST EQUIPMENT. - To select the optional output center frequency, the following test equipment (table 5-1) is required:

1. Frequency counter, with plug-in unit.

(b) INSTRUCTIONS. - To select the optional output center frequency requires changing values of R6 on the frequency calibration module (A4). After the choice of the optional output center frequency has been made, refer to table 5-4. For each value of A4R6, listed in Column 2 of table 5-4, there is a corresponding range of frequencies in Column 1. Find the resistor value in Column 2 which corresponds to the range of frequencies in which the desired output center frequency falls. For example, if an output center frequency of 1500 cps is desired, the proper value of A4R6 is 1800 ohms. 1800 ohms is the resistor value which corresponds to the frequency range (1440 to 1755 cps) into which 1500 cps falls.

1. Replace A4R6 with resistor of proper value and set the MODE switch to TTY NORM, the TTY DEVIATION CPS control to 000, and the CTR FREQ (CPS) switch to OPT.

2. Connect the frequency counter to the OUTPUT MONITOR jack and adjust A4R16 until the desired output center frequency is indicated on the frequency counter.

f. SELECTION OF OPTIONAL CW 2000 CPS OUTPUT.

(1) INTRODUCTION. - This paragraph includes instructions for obtaining the optional cw output frequency of 2000 cps.

(a) TEST EQUIPMENT. - To select the optional cw output frequency, the following test equipment (table 5-1) is required:

1. Frequency counter, with plug-in unit.

(b) INSTRUCTIONS. - To select the optional cw output frequency:

1. Replace A2R7 by a jumper and set the MODE and FUNCTION TEST switches to CW.

2. Connect the frequency counter to the OUTPUT MONITOR jack and adjust A2R8 for a reading of 2000 cps on the frequency counter.

5-3. REPAIR.

a. GENERAL. - Keyer, Frequency Shift KY-655/FRT is designed and constructed to require a minimum repair effort. The entire keyer is composed of readily accessible and removable subassemblies and modules. Paragraph 5-4 contains complete instructions for the removal and replacement of subassemblies within the keyer.

WARNING

Remove primary power from equipment before attempting module removal, replacement, or any repair procedures.



TABLE 5-4. RESISTANCE VALUES OF A4R6 FOR  
VARIOUS FREQUENCY RANGES

COLUMN 1		COLUMN 2
MINIMUM FREQUENCY (CPS)	MAXIMUM FREQUENCY (CPS)	A4R6 VALUE* (OHMS)
400	465	13,500
435	500	12,000
465	530	11,000
505	575	10,000
530	605	9,100
575	660	8,200
625	720	7,500
675	780	6,800
710	835	5,600
785	920	5,200
845	995	4,700
915	1080	3,900
1040	1240	3,300
1160	1385	2,700
1300	1580	2,200
1440	1755	1,800
1560	1925	1,500
1810	2270	1,000
1925	2440	820
2040	2620	620
2200	2800	470
2400	3000	390

\* Use 1% tolerance, wirewound precision resistors.

b. MODULE REPAIR. - Module repair, at a field maintenance level, will consist of identifying, removing, and replacing the faulty module or plug-in printed circuit card. In the event that emergency repairs are necessary in the field, observe all precautions applicable for unsoldering and soldering small parts on printed circuit boards. Small parts (resistors, capacitors, diodes, etc.) may be damaged by excessive heat during soldering. Use a heat sink such as long-nose pliers or metal clips between the heat source and the part to be soldered. Solder as rapidly as possible and use a low wattage soldering iron.

c. USE OF PARTS LOCATION AND SCHEMATIC DIAGRAMS. - When repairing any part of a subassembly of the keyer, refer to the applicable parts location diagram and schematic included at the end of this section. These diagrams (when used with the parts information supplied in Section 6) fully identify and locate all replaceable electrical parts.

5-4. REMOVAL AND REPLACEMENT.

a. GENERAL. - This paragraph contains instructions for the removal of modular subassemblies from the keyer and their subsequent replacement. The procedures given below should be followed carefully to prevent damaging the equipment. Force should not be used when removing or inserting modules to avoid damaging the multipin connectors.

b. PROCEDURES.

(1) TTY SELECTOR (A1).

(a) REMOVAL. - Refer to paragraph 2-4c for instructions for opening, indexing, and closing the keyer drawer, and loosen the captive mounting screws which secure the A1 module to the keyer chassis. Remove the tty selector module plug A1P1 from the keyer chassis receptacle A6XA1; remove the module.

(b) REPLACEMENT. - Position the A1 module into place on the keyer chassis, fasten the captive mounting screws, and carefully insert A1P1 into A6XA1.

(2) KEYER AND TRANSITION RELAY (A2).

(a) REMOVAL. - Refer to paragraph 2-4c for operation of the keyer drawer and loosen the captive mounting screws on the A2 module, and remove the keyer and transition relay module plug A2P1 from the keyer chassis receptacle A6XA2; remove the module.

(b) REPLACEMENT. - Position the A2 module into place on the keyer chassis, fasten the captive mounting screws, and carefully insert A2P1 into A6XA2.

(3) FREQUENCY SHIFT OSCILLATOR (A3). (See figure 5-14.)

(a) REMOVAL.

1. Refer to paragraph 2-4c for operation of the keyer drawer.

2. Remove the mounting nuts which secure the A3 module to the bottom of the keyer chassis.

3. Disconnect the keyer chassis plug P2 from the oscillator receptacle A3J1; remove the frequency shift oscillator module from the chassis.

4. Remove the mounting screws which secure the cover to the frequency shift oscillator module; remove the cover.

5. Remove the mounting screws which secure the cavity cover to the module; slowly remove the cavity cover disconnecting the heater sensor plug at the same time.

6. Remove the screws from the corners of oscillator board #2 (A3A2).

7. Separate oscillator boards #1 and #2 (A3A1 and A3A2) by unsoldering the interconnection wires. Label unsoldered connections for proper reassembly.

(b) REPLACEMENT. - Reverse the removal procedures given in paragraph (a).

(4) FREQUENCY CALIBRATION (A4).

(a) REMOVAL. - Refer to paragraph 2-4c for operation of the keyer drawer and loosen the screws securing the A4 module to the keyer chassis. Remove the frequency calibration module plug A4P1 from the keyer chassis receptacle A6XA4; remove the module.

(b) REPLACEMENT. - Position the A4 module into place on the keyer chassis, fasten the captive mounting screws, and carefully insert A4P1 into A6XA4.

(5) AUDIO AMPLIFIER (A5).

(a) REMOVAL. - Refer to paragraph 2-4c for operation of the keyer drawer and loosen the captive mounting screws on the A5 module, and remove the audio amplifier module plug A5P1 from the keyer chassis receptacle A6XA5; remove the module.

(b) REPLACEMENT. - Position the A5 module into place on the keyer chassis, fasten the captive mounting screws, and carefully insert A5P1 into A6XA5.

(6) POWER SUPPLY (PS1). (See figure 5-15.)

(a) REMOVAL.

1. Refer to paragraph 2-4c for instructions for opening, indexing, and closing the keyer drawer.

2. Remove keyer chassis plug P1 from the power supply receptacle PS1J1.

3. Loosen the captive mounting screws which secure the power supply module to the keyer chassis; remove the module.

4. Remove the screws which secure the cover to the power supply module; remove the cover.

5. Remove the relay control board (PS1A1) by removing the screws which secure it to the side of the module frame, and unsolder the interconnecting wires. Label unsoldered connections for proper reassembly.

6. Remove the mounting screws on the side, and the mounting screws on the bottom of the module frame which secure the board assembly; remove the board assembly.

7. Remove the rectifier/filter board (PS1A4) from the board assembly by removing the mounting screws and spacers. Unsolder the interconnection wires and label unsoldered wires for proper reassembly.

8. Remove the  $\pm 18$  vdc regulator board (PS1A3) by unsoldering the interconnection wires. Label unsoldered connections for proper reassembly.

9. Remove the  $\pm 10$  vdc regulator board (PS1A2) by removing the mounting screws on the side of the board assembly. Unsolder the connection wires; label unsoldered connections for proper reassembly.

(b) REPLACEMENT. - Reverse the removal procedures given in paragraph (a).

5-5. MAINTENANCE ILLUSTRATIONS.

The illustrations, located at the end of this section, are for use by the technician to maintain, trouble shoot, and repair the keyer. They consist of parts location illustrations, schematic diagrams, and a primary-power distribution diagram.

a. PART LOCATION ILLUSTRATIONS. - Figures 5-1 through 5-13 are the part locations illustrations. They identify, by means of callouts, the relative location of all circuit elements.

b. PRIMARY POWER DISTRIBUTION DIAGRAM. - Figure 5-16 shows the distribution of primary power in the keyer. It is an across-the-line type diagram showing the circuit elements directly related to the distribution of ac primary power within the set.

c. SCHEMATIC DIAGRAMS. - Schematic diagrams of each module in the receiving set, together with the module interconnection diagrams, are provided in figures 5-17 through 5-23. Where applicable, primary signal flow is indicated by a heavyweight line with arrowheads to indicate the direction of flow. Secondary signal paths, where applicable, are indicated by lightweight lines with arrowheads. The following information applies to all schematic diagrams in this section of the manual:

- (1) All part values are given in ohms, picofarads, and microhenries unless otherwise indicated.
- (2) The dc resistance of indicators and transformer windings is omitted if less than one ohm.
- (3) All resistors are rated 1/4 watt unless otherwise indicated.
- (4) All dc voltages are measured between card terminals and the keyer chassis using a 20,000 ohm-per-voltmeter, unless otherwise indicated. All ac voltage measurements are performed using a 1000 ohm-per-voltmeter unless otherwise indicated.
- (5) All relays are shown de-energized.

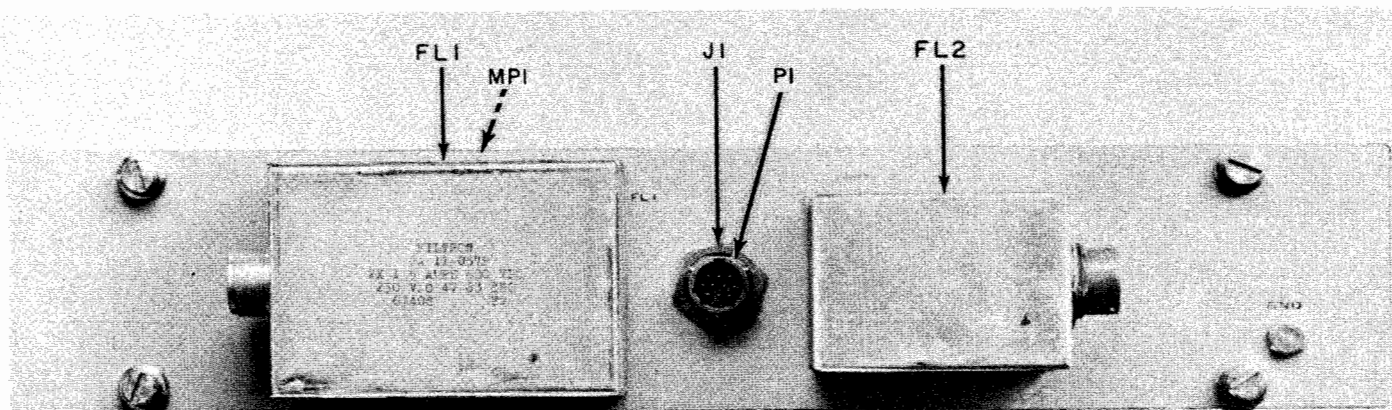

(A7) FILTER PANEL ASSEMBLY

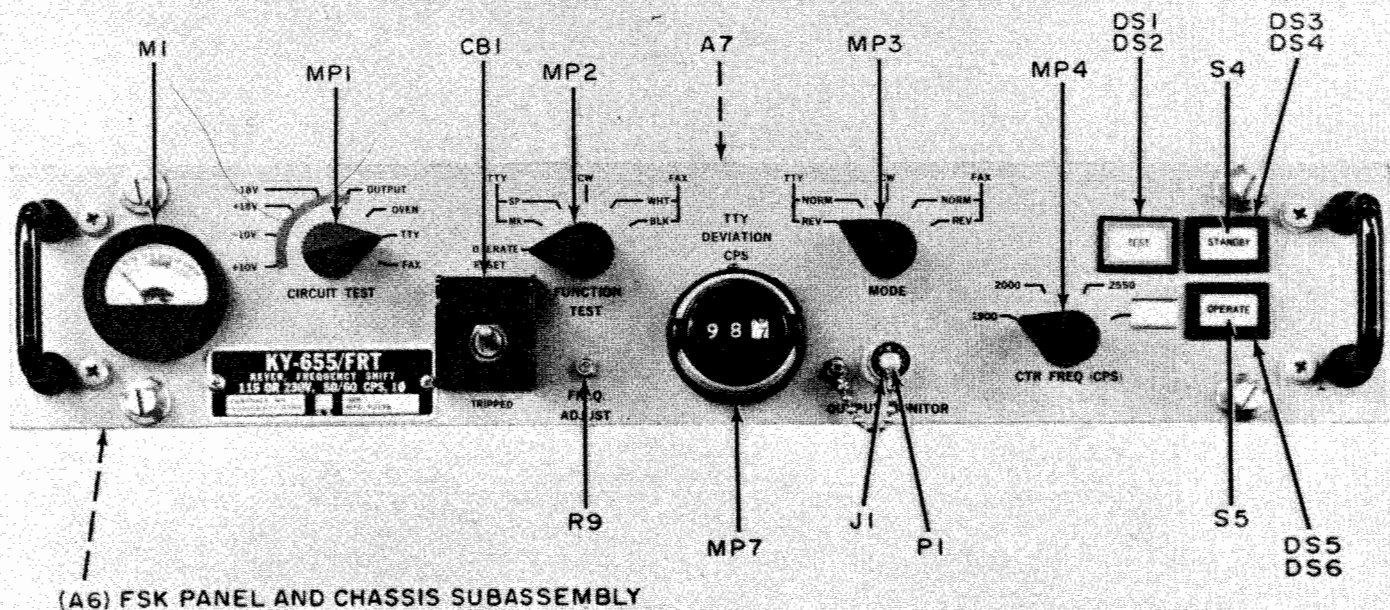

(A6) FSK PANEL AND CHASSIS SUBASSEMBLY

Figure 5-1. Assembly and Component Location Diagram (Sheet 1 of 2)

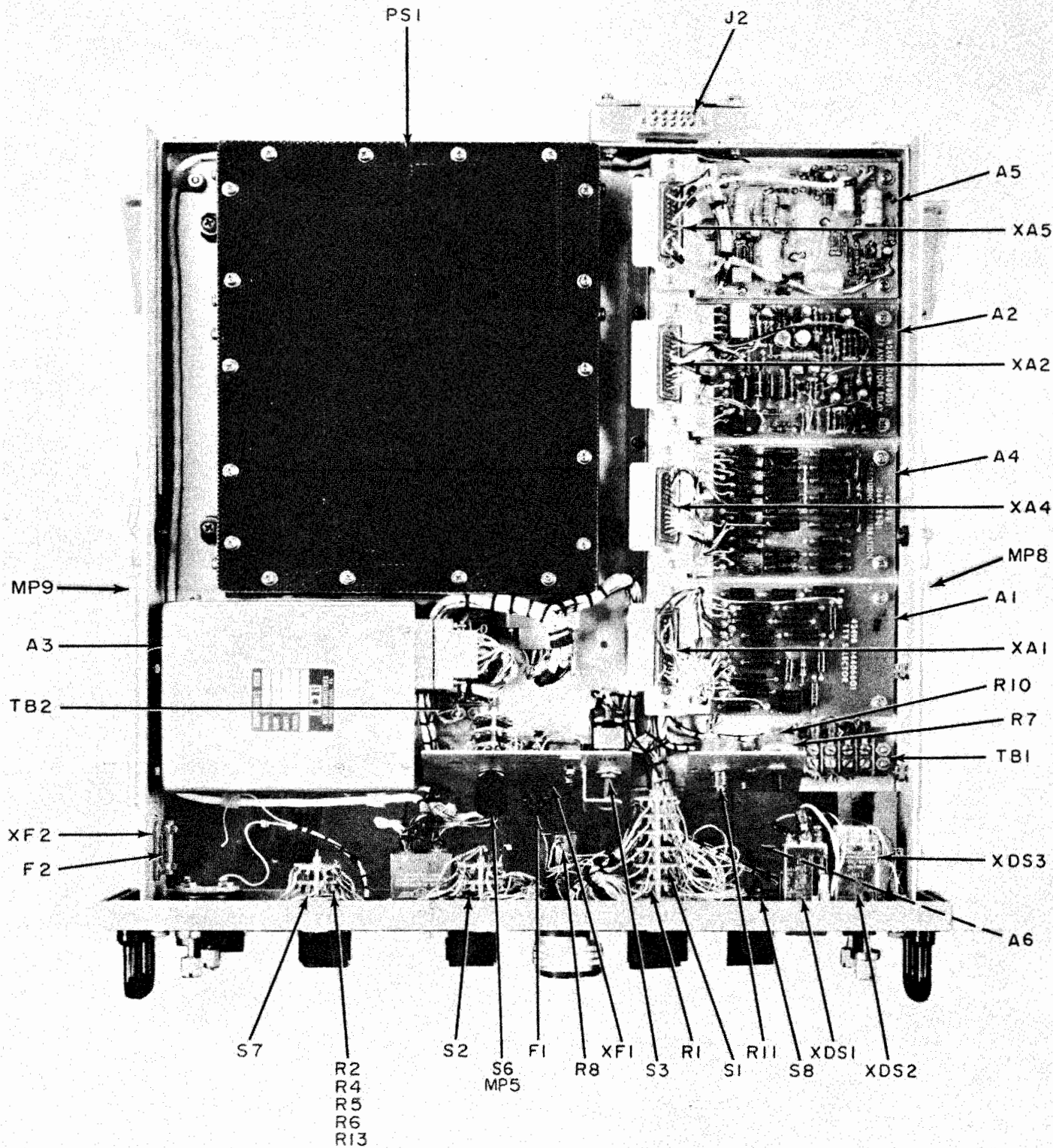

Figure 5-1. Assembly and Component Location Diagram (Sheet 2 of 2)

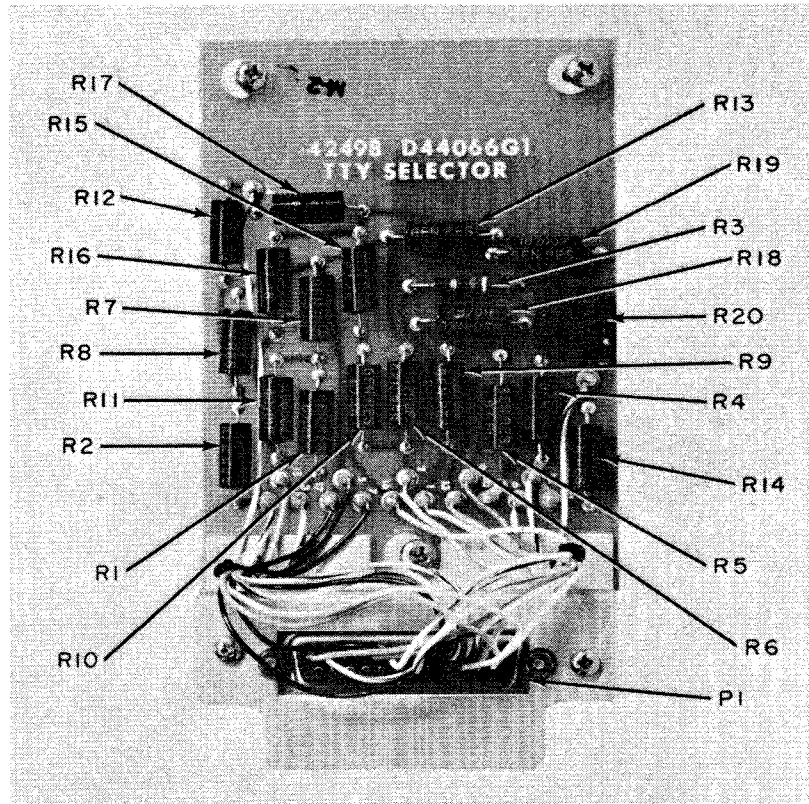

Figure 5-2. TTY Selector (A1), Component Location Diagram

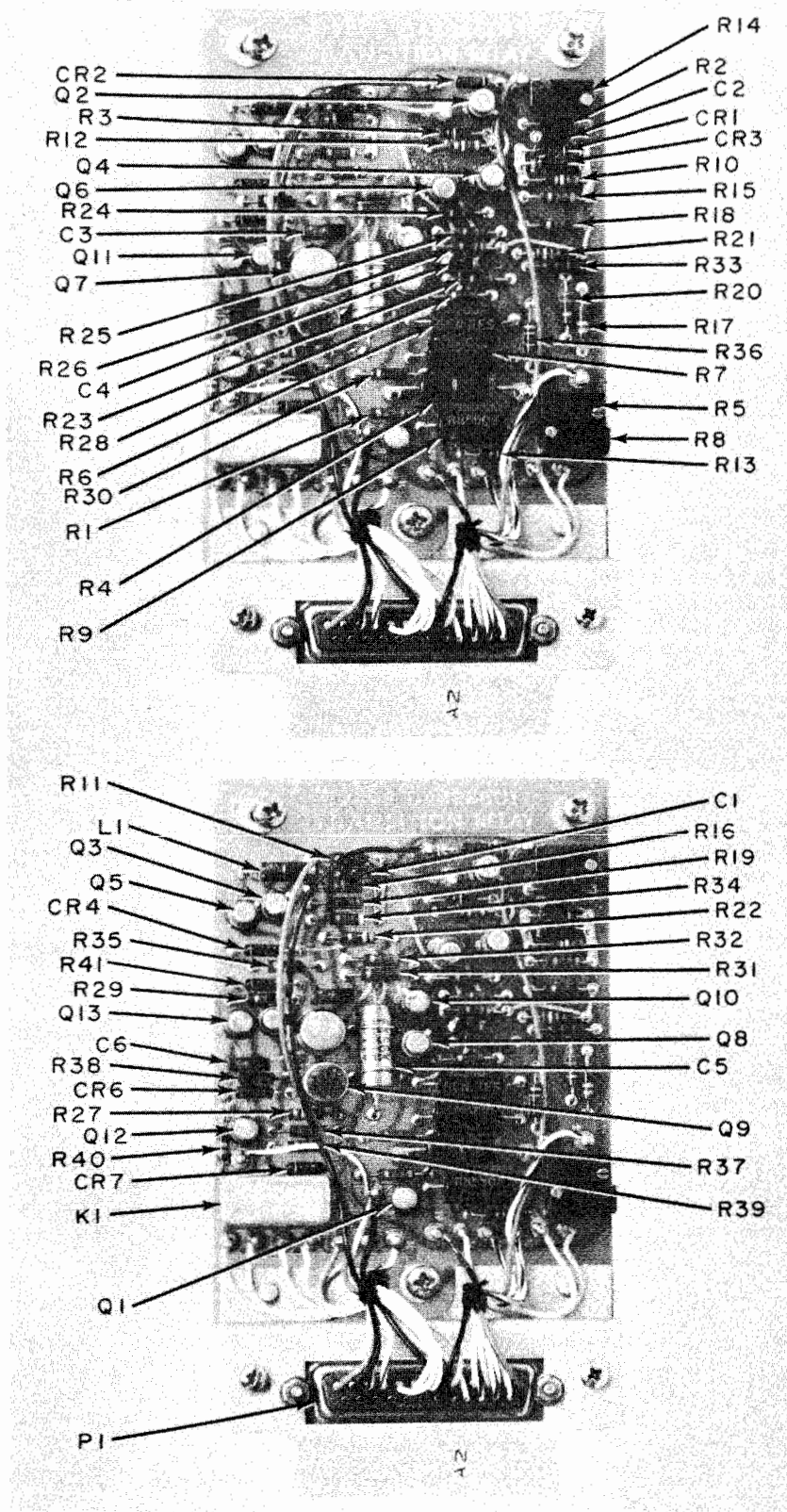

Figure 5-3. Keyer and Transition Relay (A2), Component Location Diagram



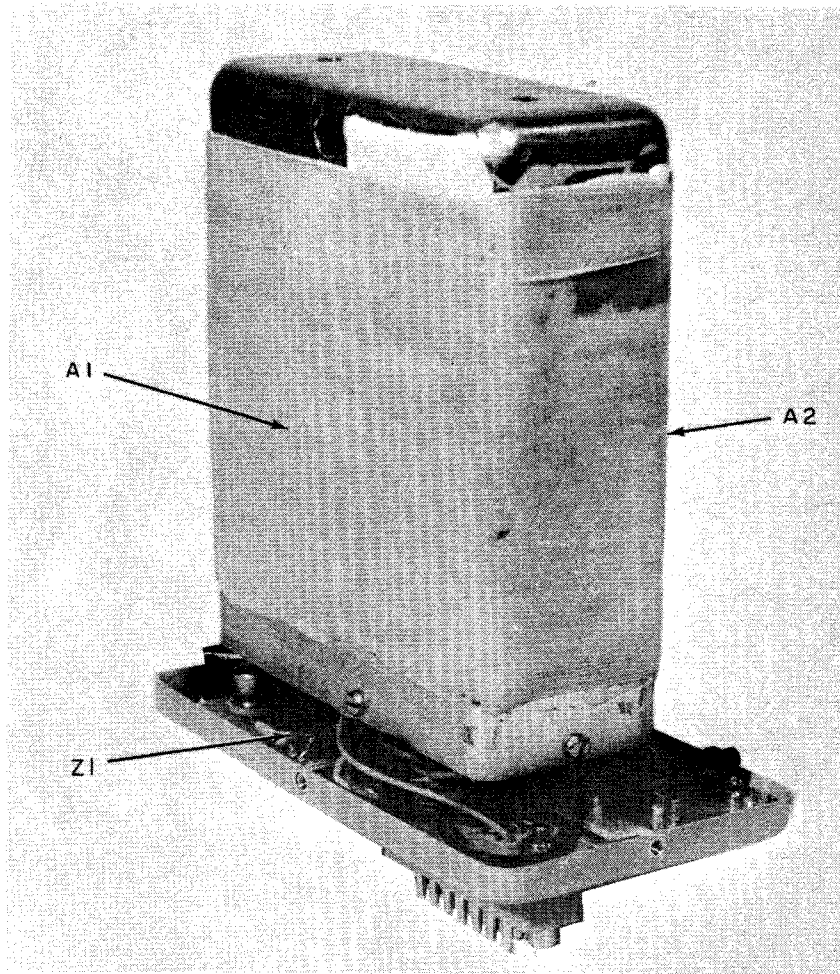

Figure 5-4. Frequency Shift Oscillator (A3), Component Location Diagram

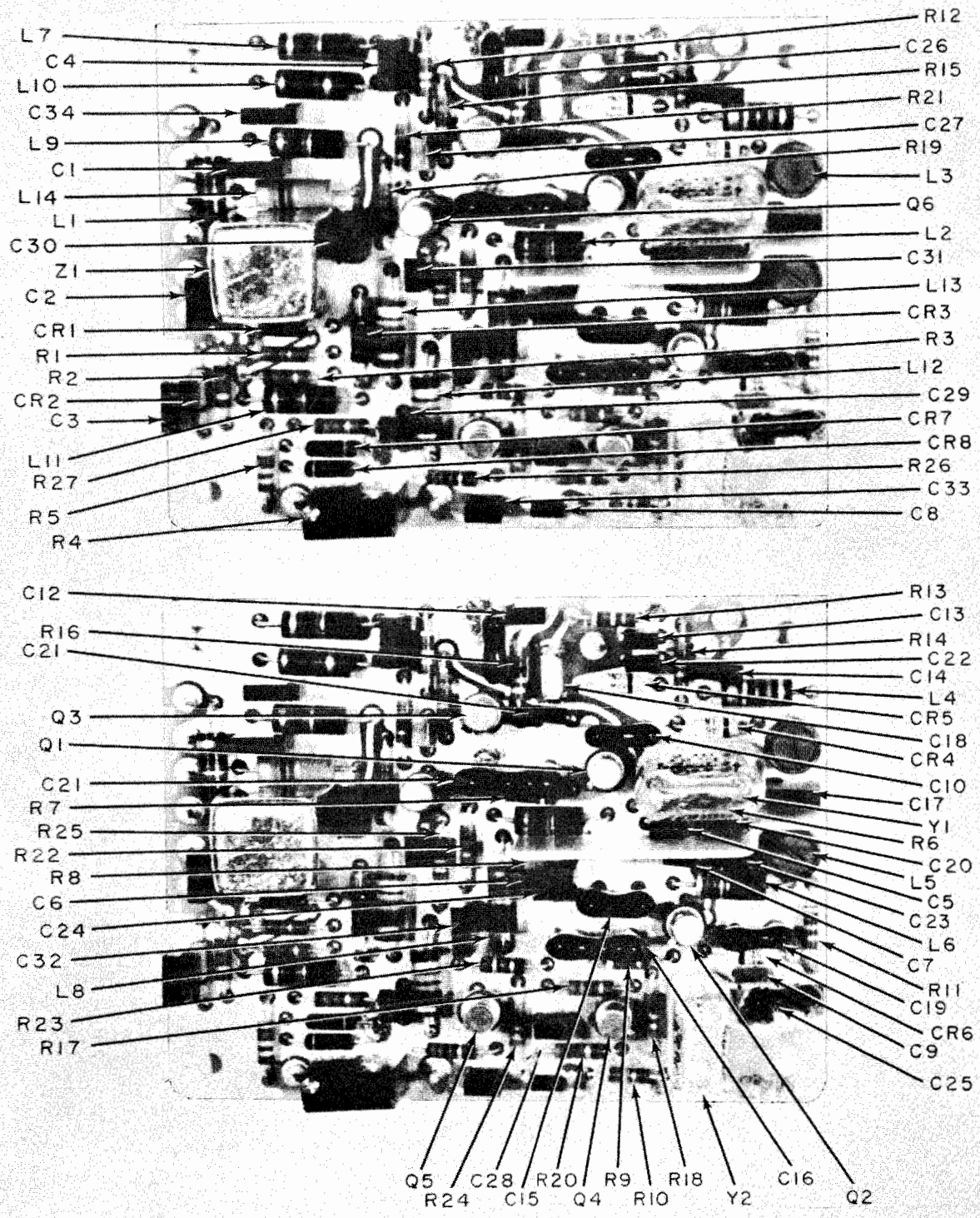

Figure 5-5. Oscillator Board No. 1 (A3A1), Component Location Diagram

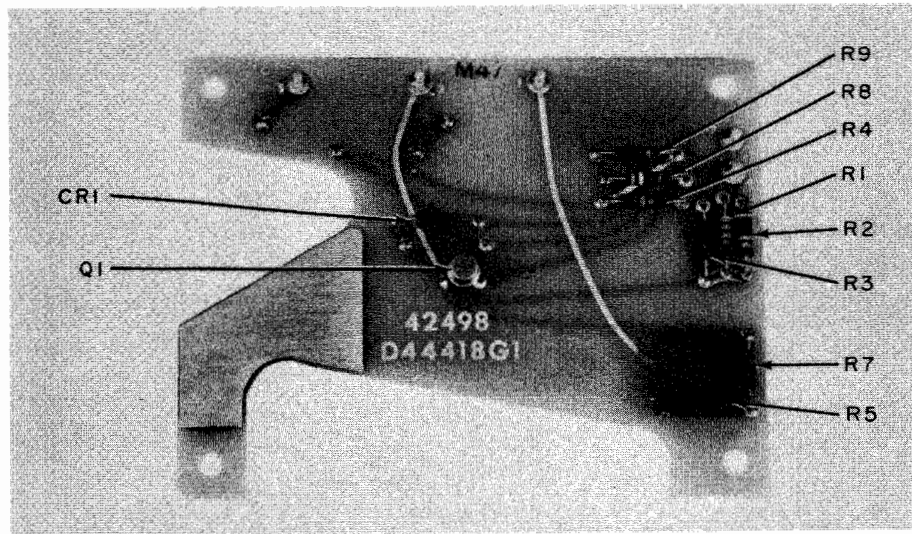

Figure 5-6. Oscillator Board No. 2 (A3A2), Component Location Diagram

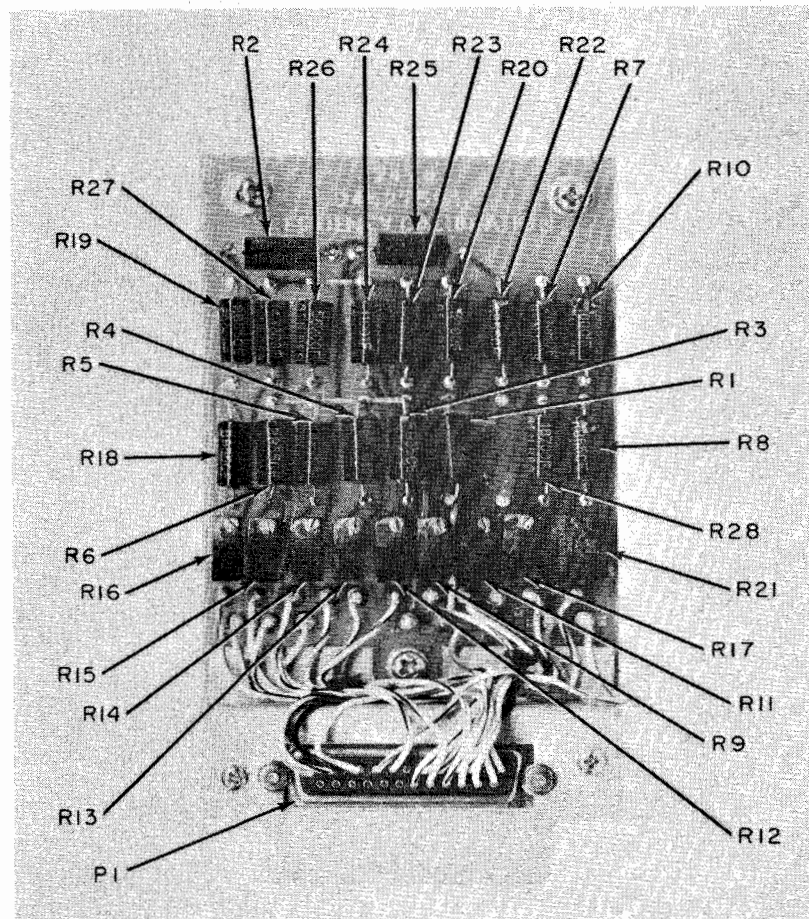

Figure 5-7. Frequency Calibration (A4), Component Location Diagram

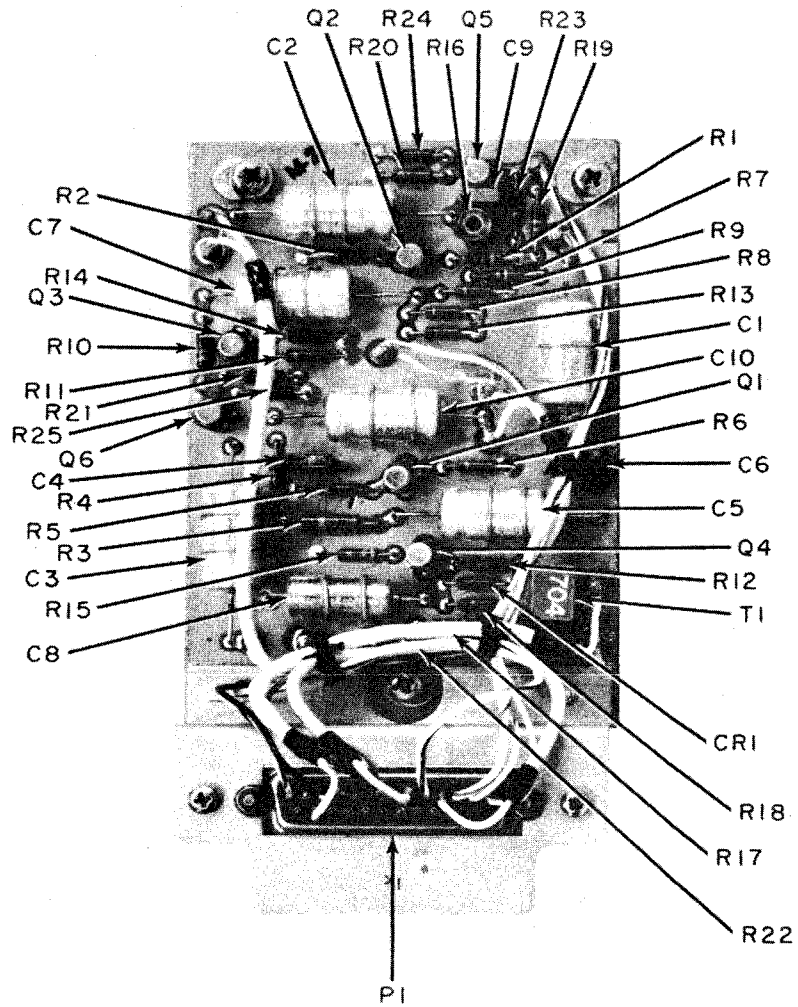

Figure 5-8. Audio Amplifier (A5), Component Location Diagram

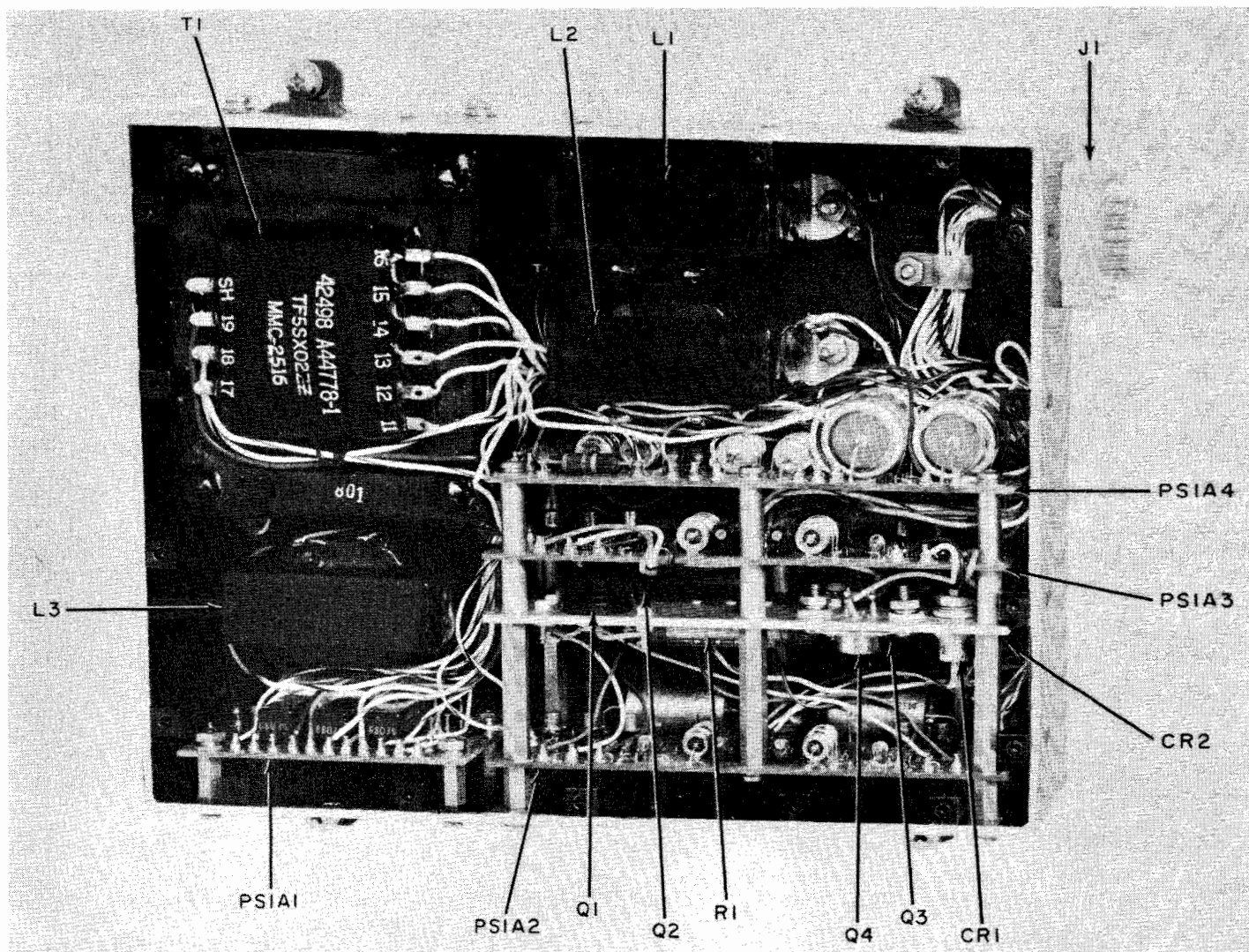

Figure 5-9. Power Supply (PS1), Component Location Diagram

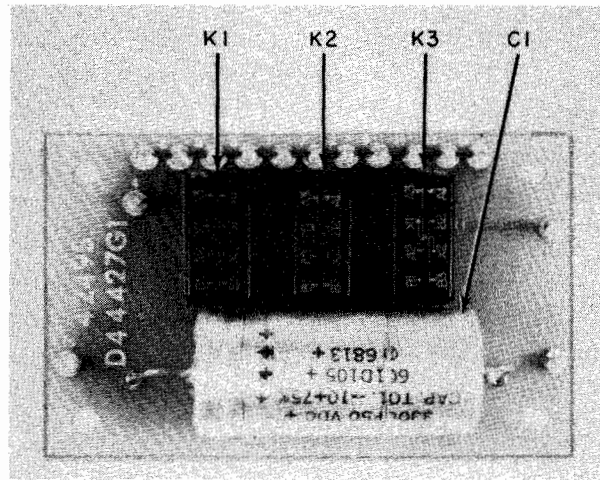

Figure 5-10. Relay Control (PS1A1), Component Location Diagram

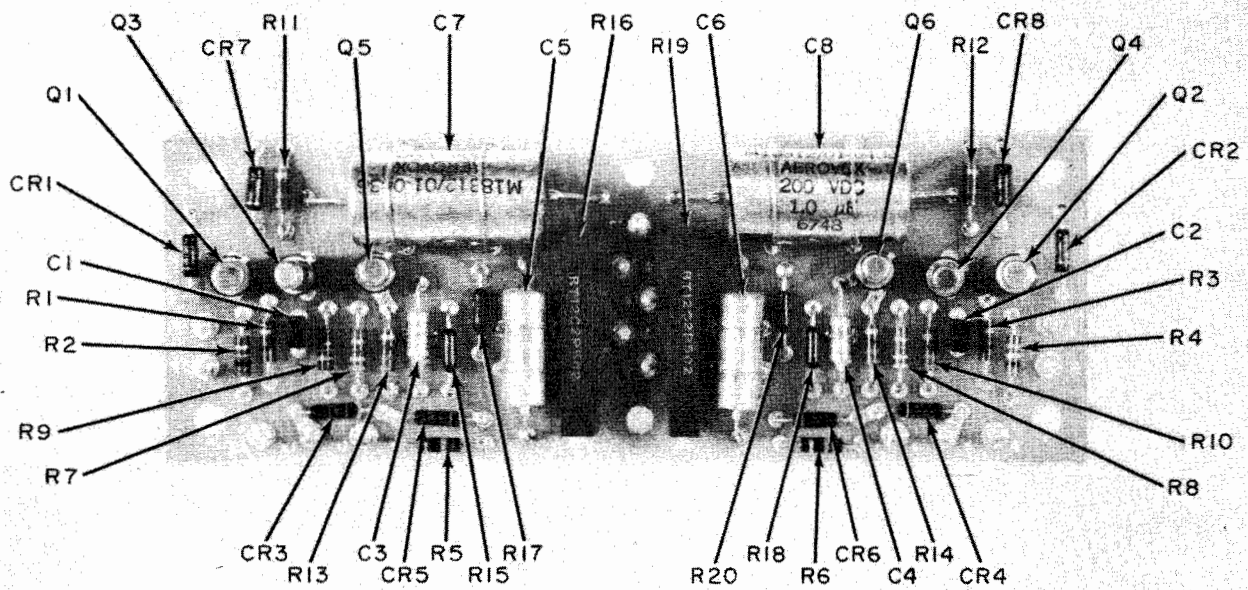

Figure 5-11. ±10 VDC Regulator (PS1A2), Component Location Diagram

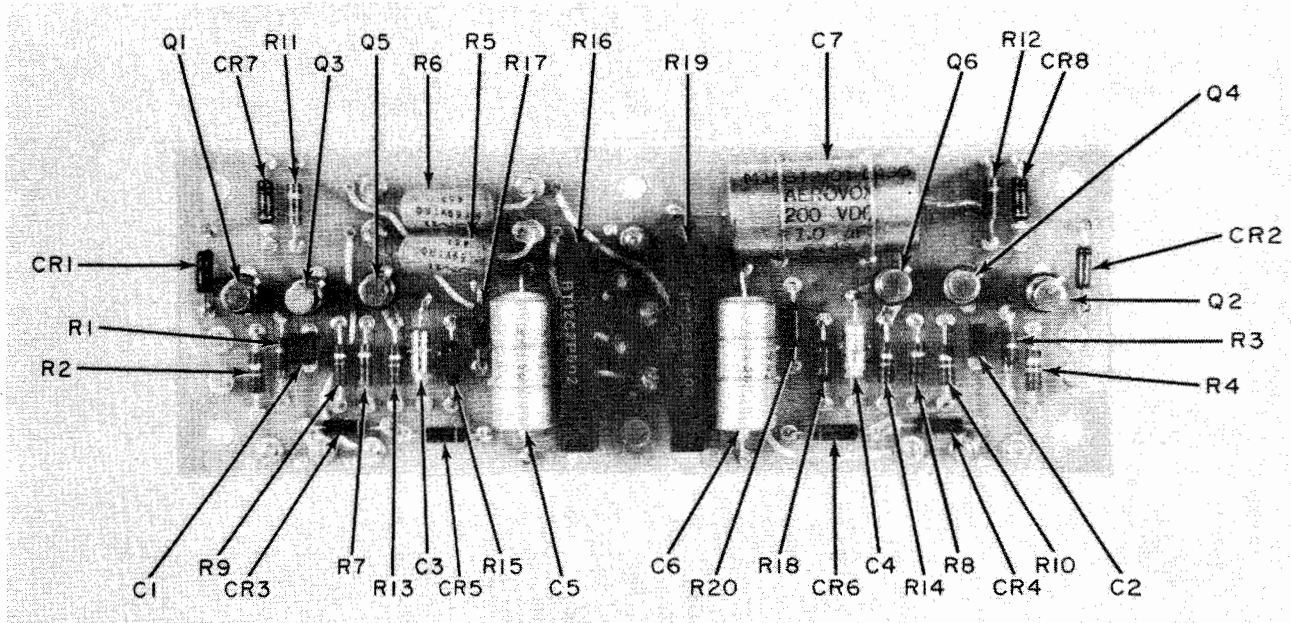

Figure 5-12.  $\pm 18$  VDC Regulator (PS1A3), Component Location Diagram

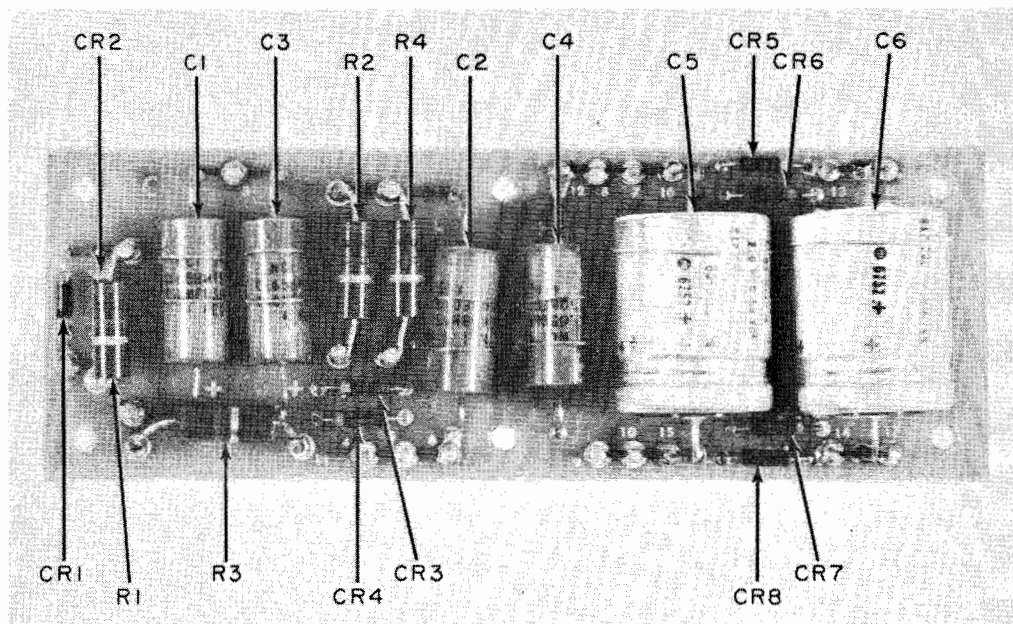

Figure 5-13. Rectifier/Filter (PS1A4), Component Location Diagram

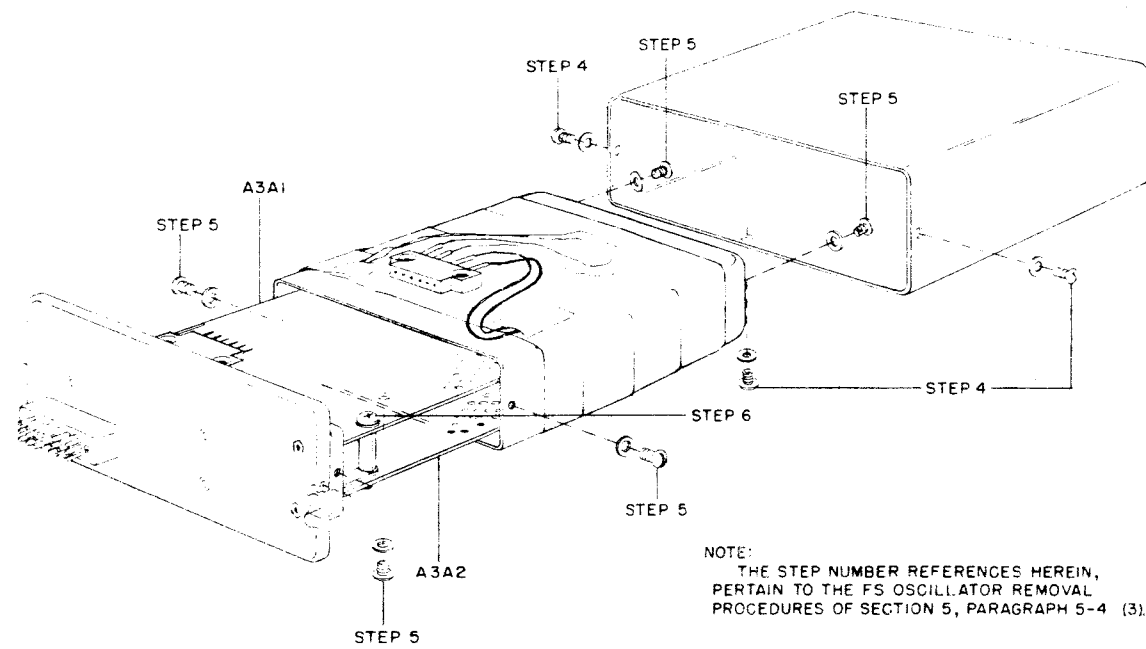

Figure 5-14. Frequency Shift Oscillator (A3), Disassembly Diagram

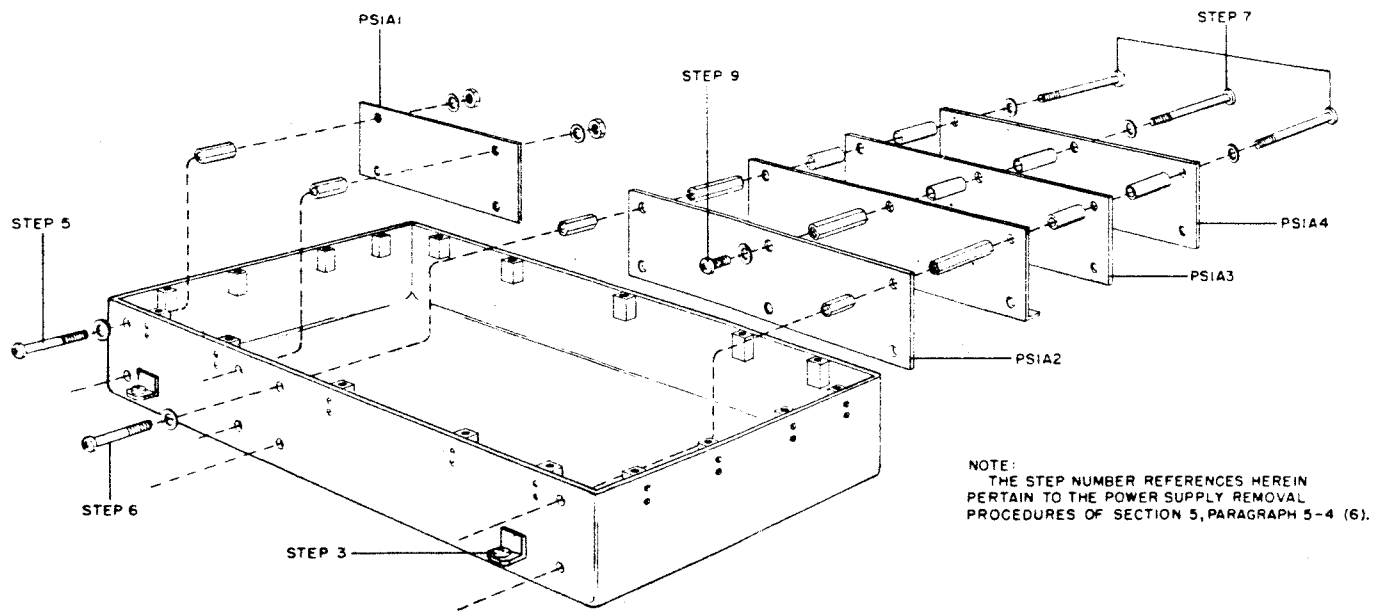
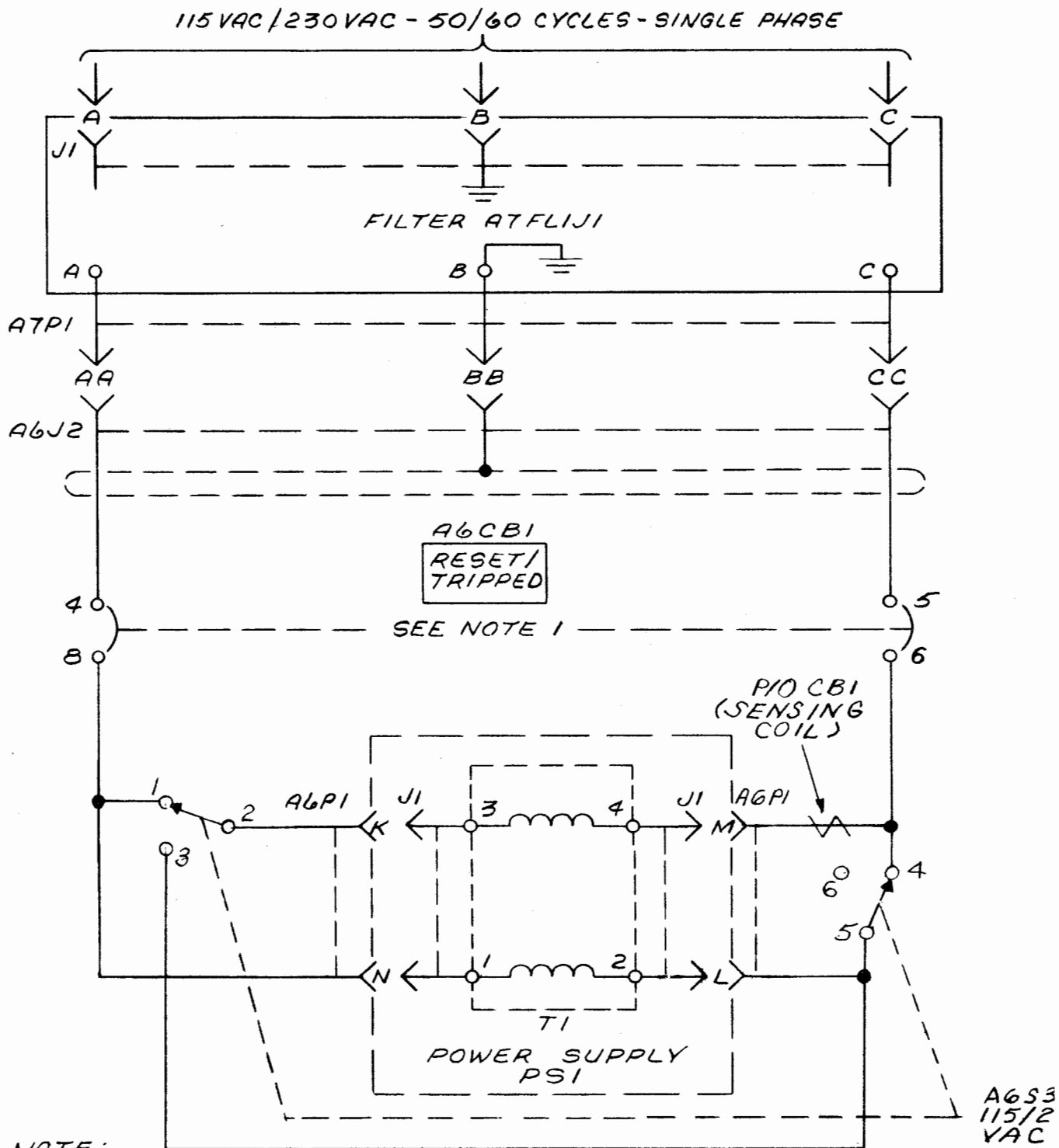

Figure 5-15. Power Supply (PS1), Removal of Printed Circuit Boards





NOTE:  
CIRCUIT BREAKER A6CB1 OPENS  
IF CURRENT EXCEEDS 1 AMP.

Figure 5-16. AC Distribution Diagram

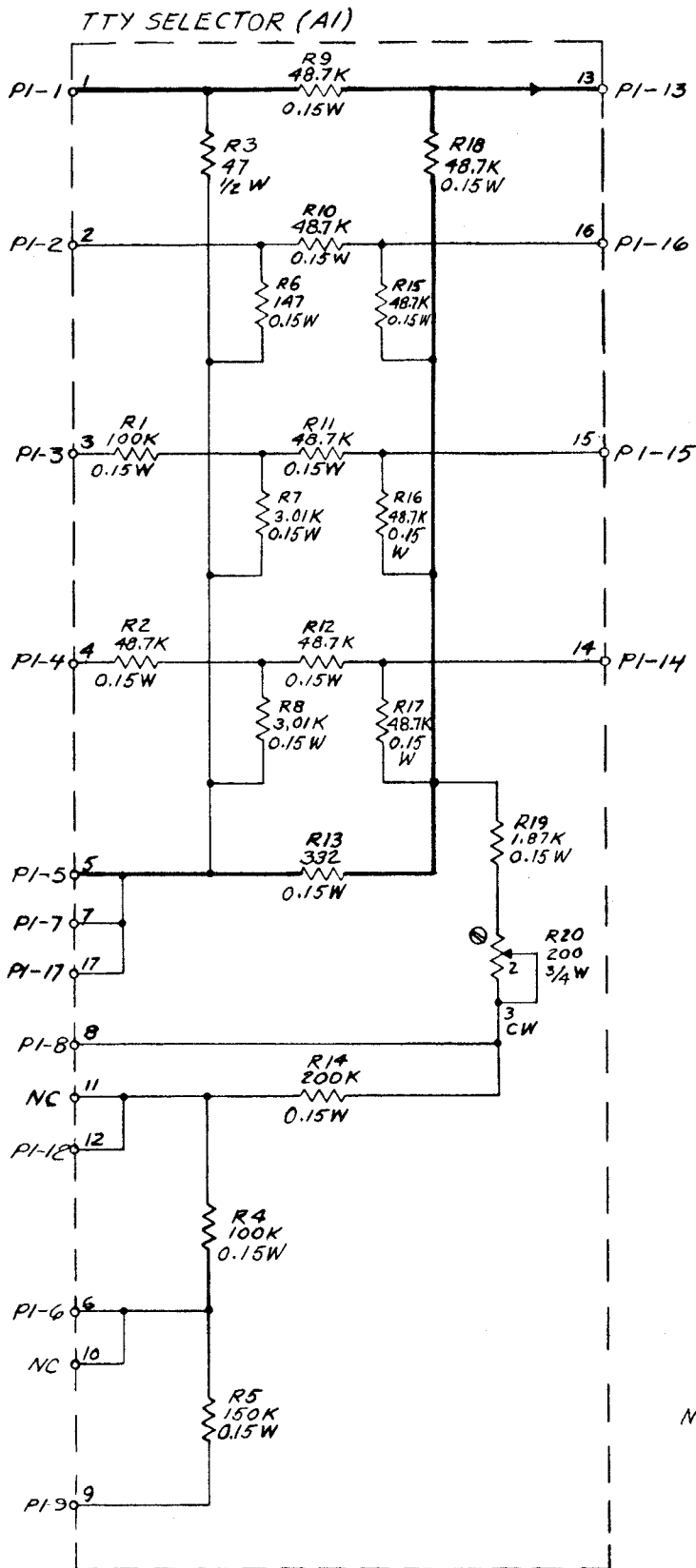

FROM	PI	CIRCUIT
A1-1	1	"60 mA"
A1-2	2	"20 mA"
A1-3	3	"100V"
A1-4	4	"50V"
A1-5	5	COM
A1-6	6	CW DRY CONTACT TTY INPUT
A1-7	7	COM
A1-8	8	-10V
A1-9	9	+10V
NC	10	SPARE
NC	11	SPARE
A1-12	12	CW DRY CONTACT
A1-13	13	"60 mA" POLAR OUT
A1-14	14	"50V" POLAR OUT
A1-15	15	"100V" POLAR OUT
A1-16	16	"20 mA" POLAR OUT
A1-17	17	COM
NC	18	SPARES
NC	19	
NC	20	
NC	21	
NC	22	
NC	23	
NC	24	
NC	25	

NOTES:

1. SHOWN IN THE 60 mA POSITION.
2. SEE PARA 5-5.

Figure 5-17. TTY Selector A1,  
Schematic Diagram

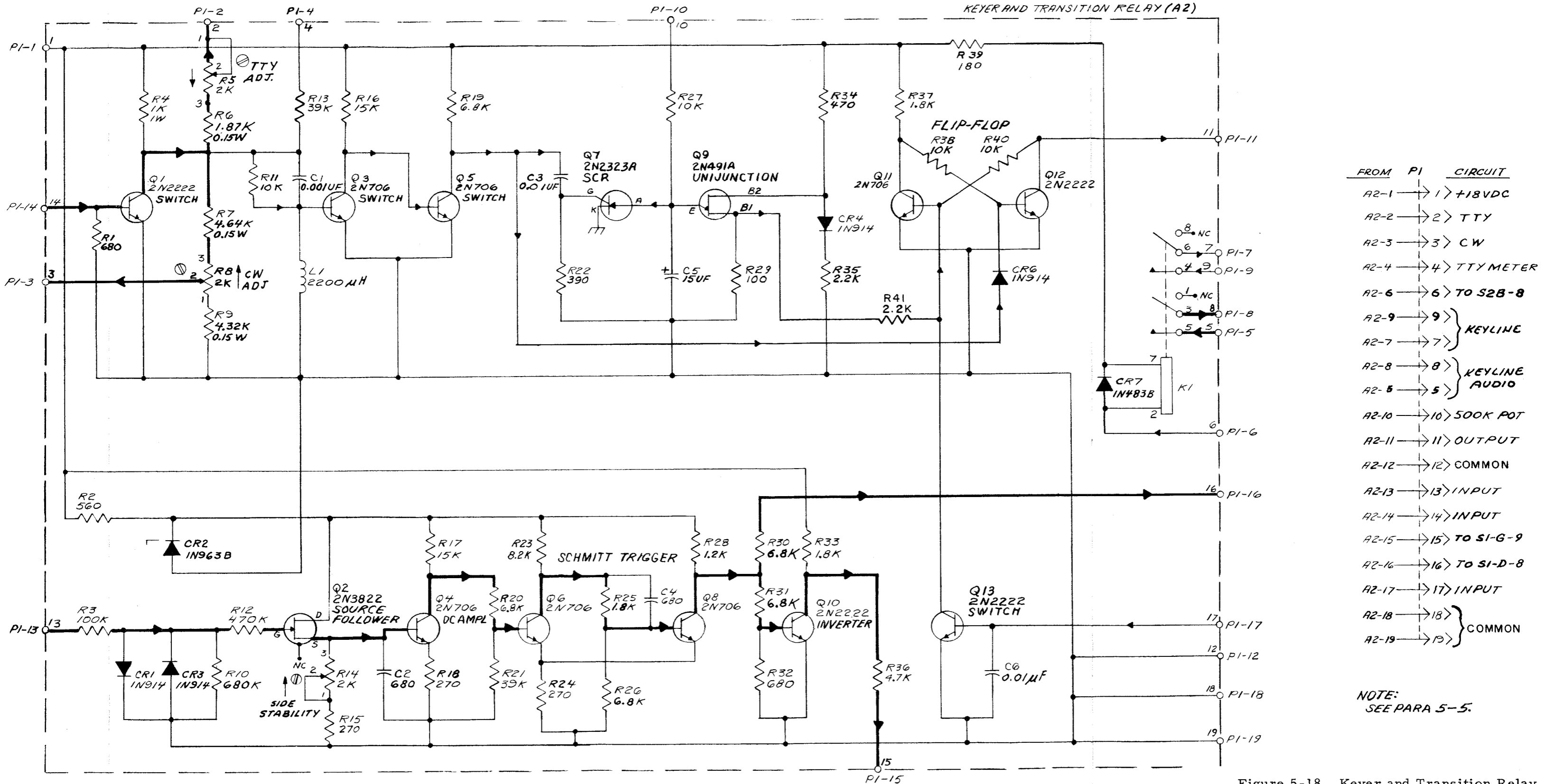

Figure 5-18. Keyer and Transition Relay (A2), Schematic Diagram

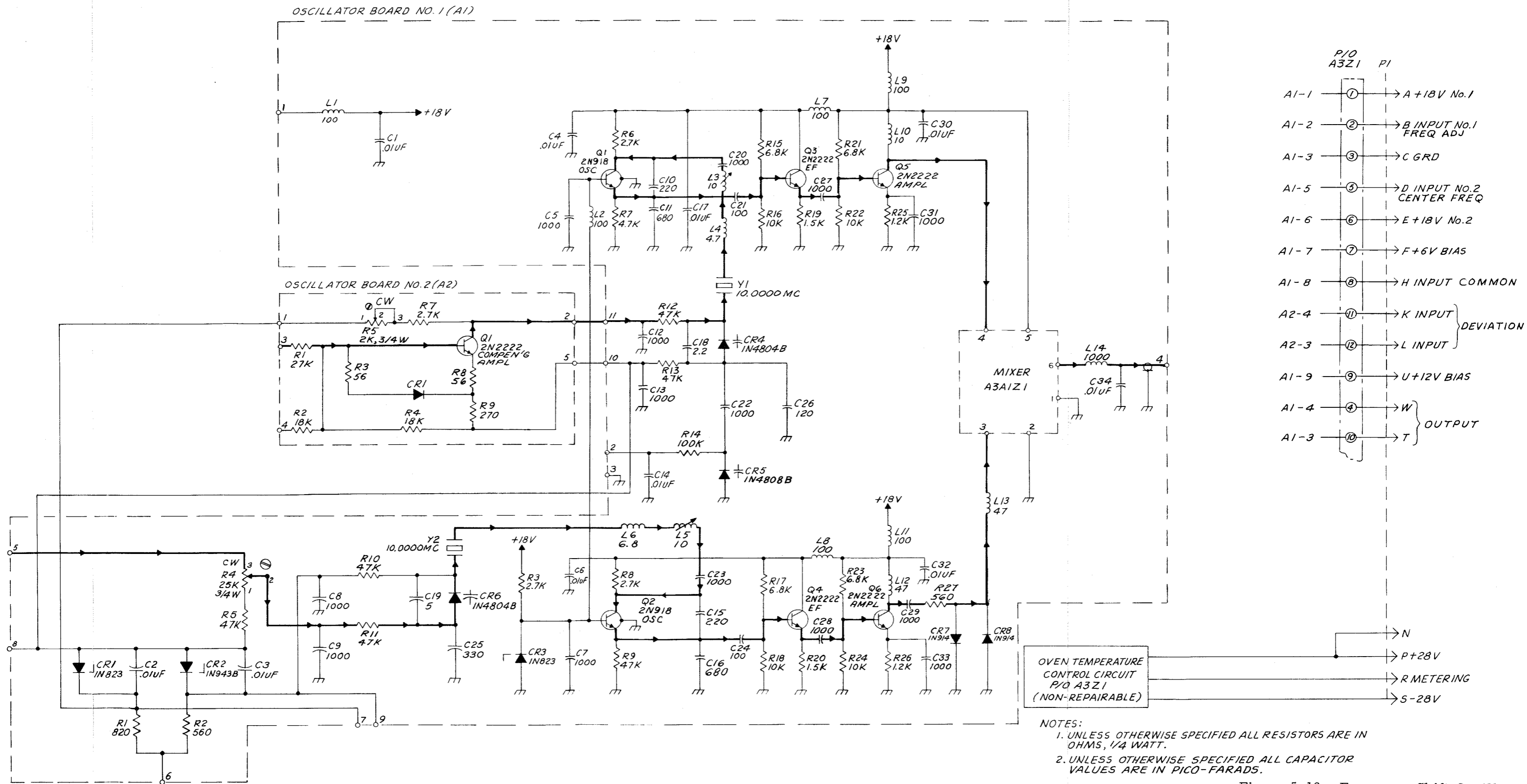
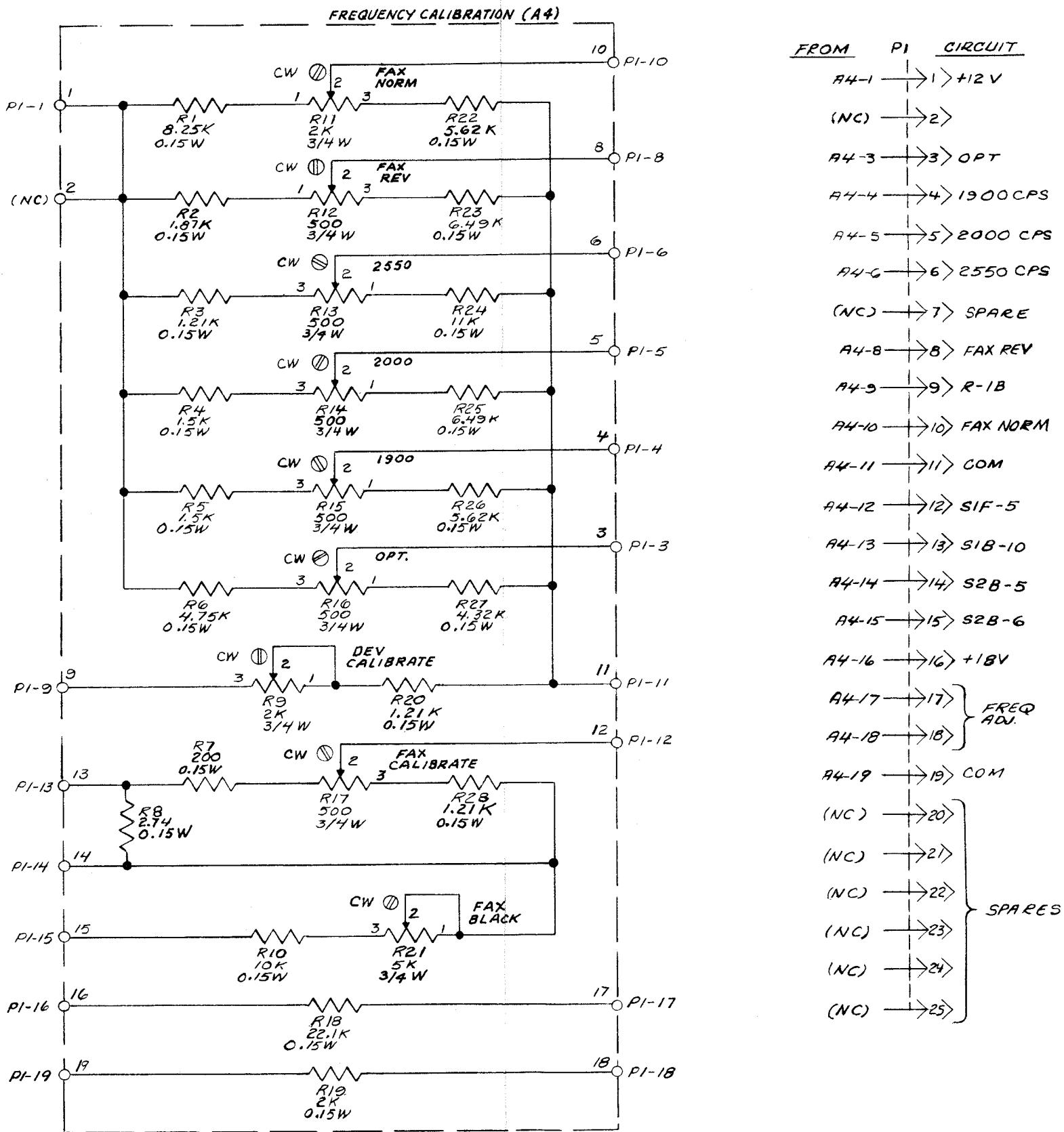

Figure 5-19. Frequency Shift Oscillator (A3), Schematic Diagram

ORIGINAL



ORIGINAL

Figure 5-20. Frequency Calibration Assembly (A4), Schematic Diagram

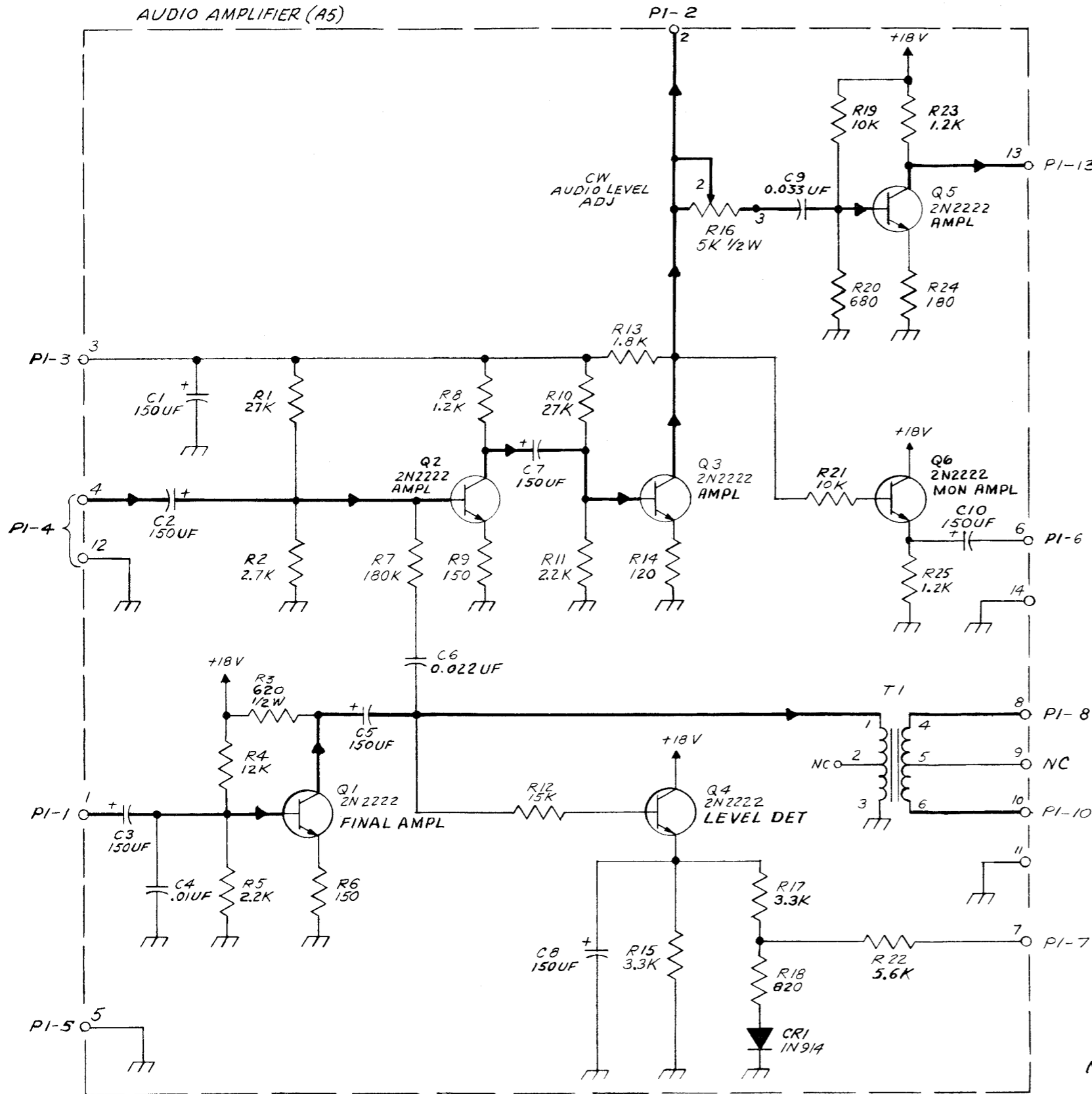

NOTE:  
SEE PARA 5-5.

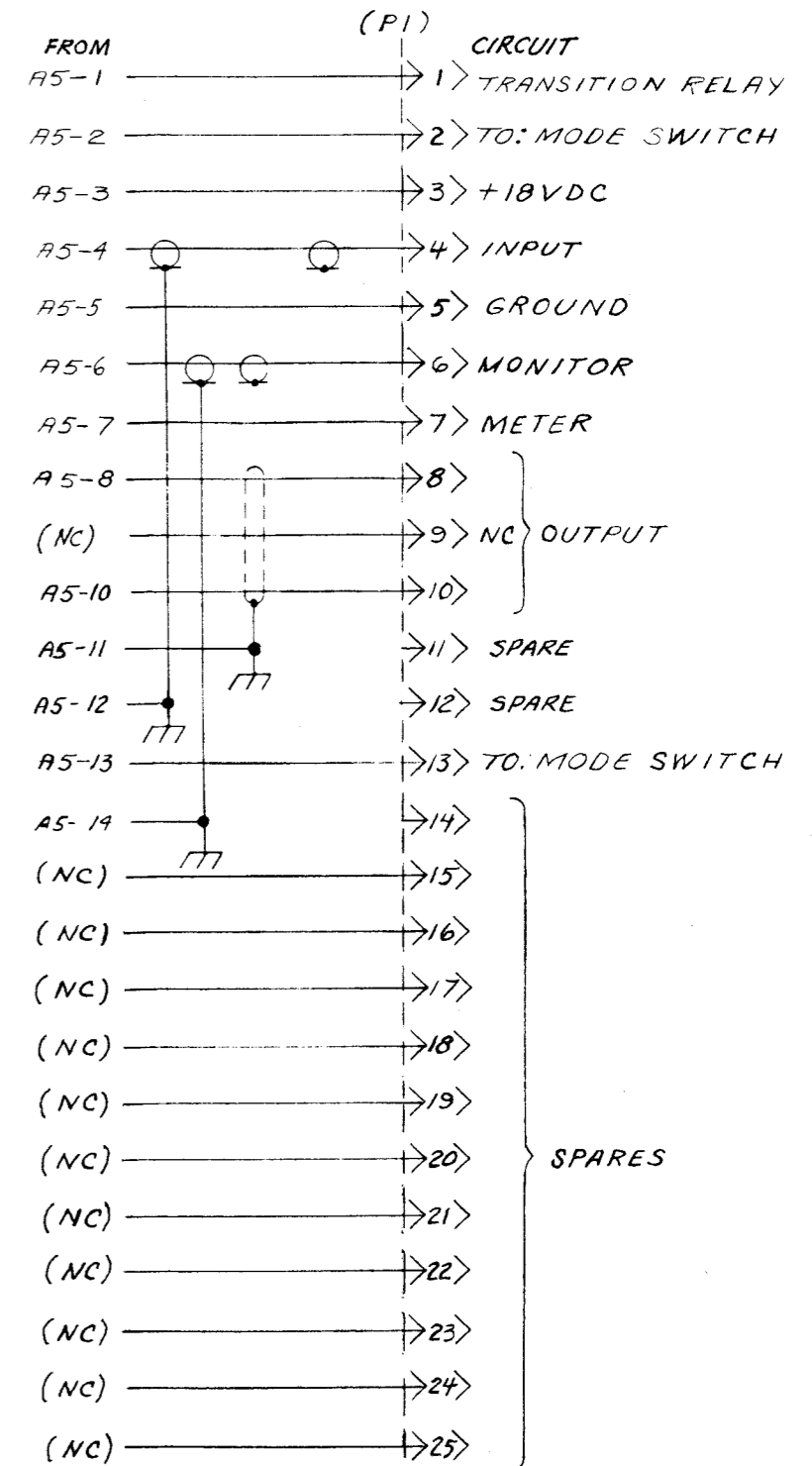

Figure 5-21. Audio Amplifier (A5),  
Schematic Diagram

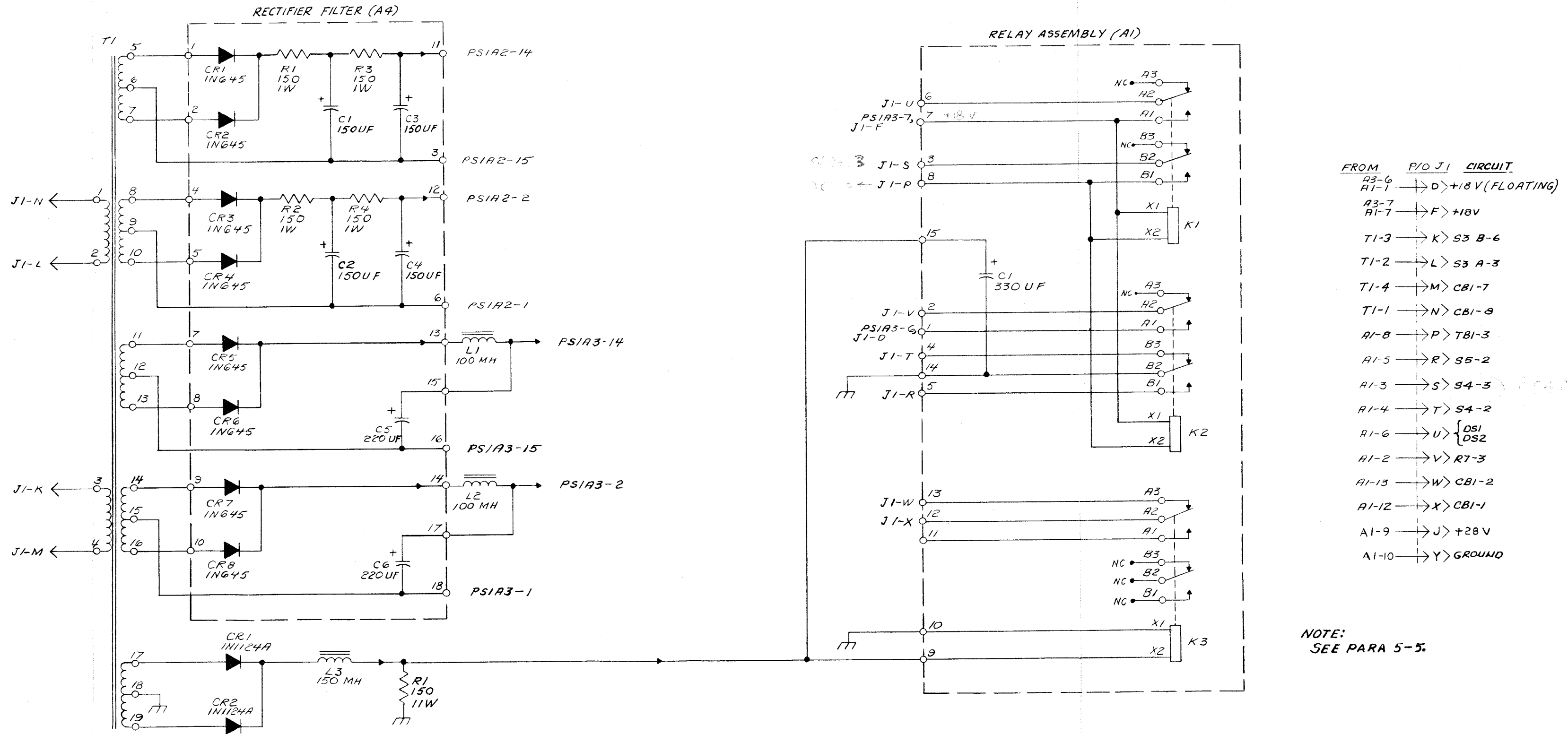
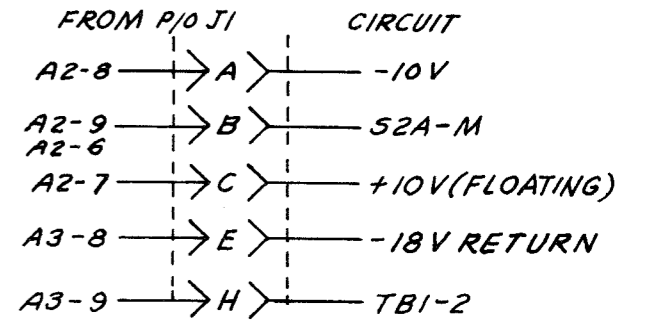
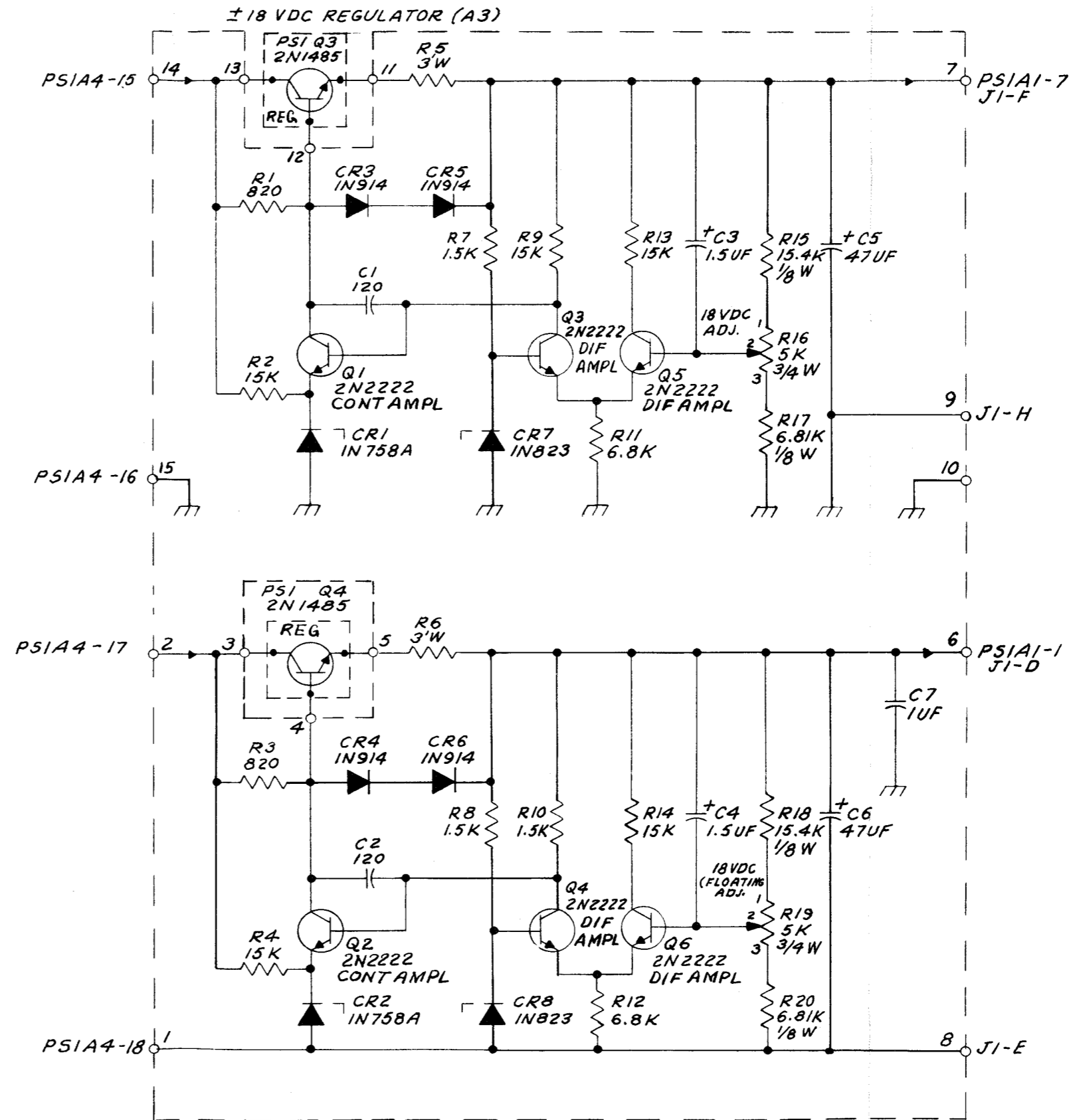
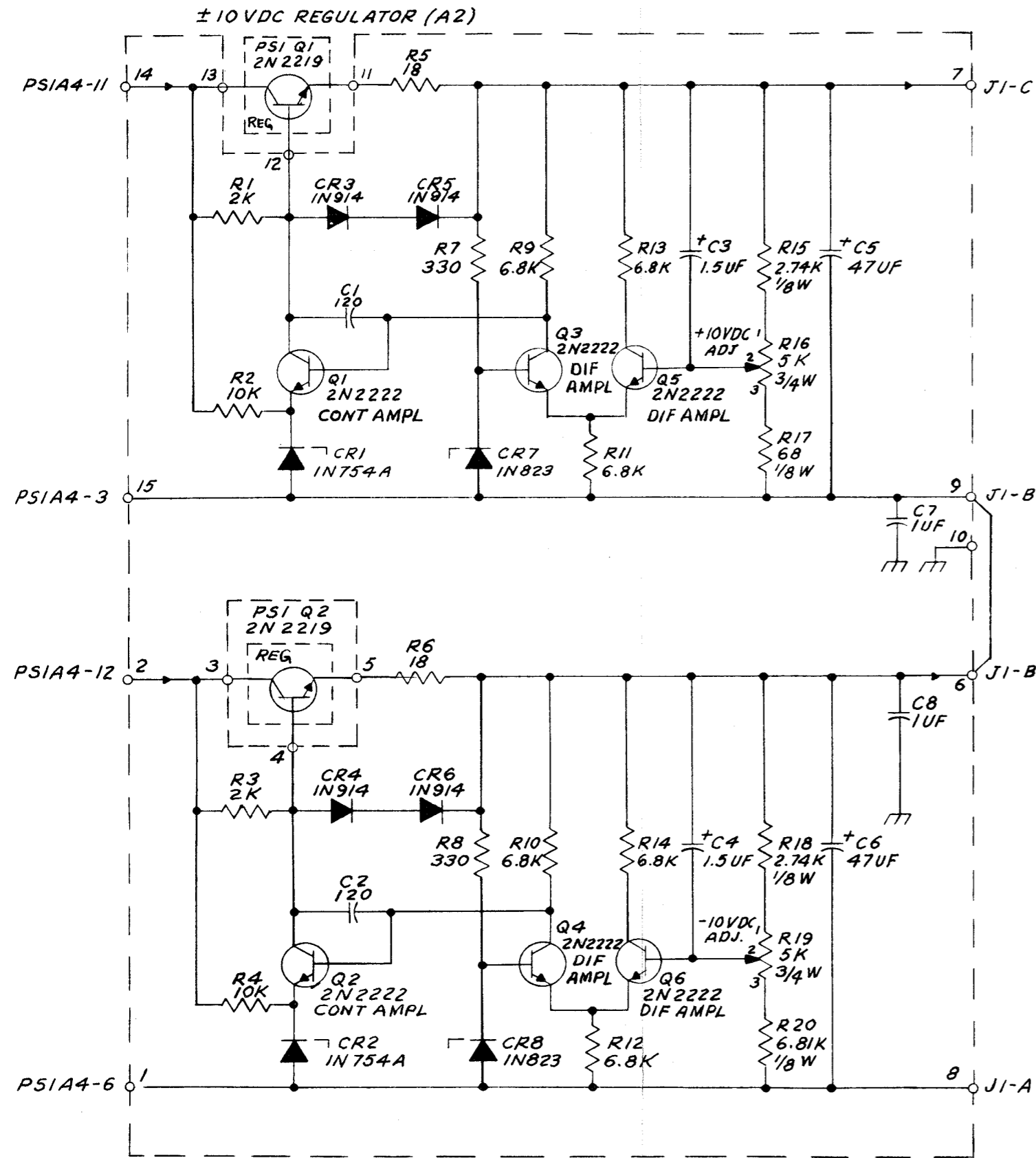

Figure 5-22. Power Supply (A1PS1),  
Schematic Diagram (Sheet 1 of 2)



NOTE:  
SEE PARA 5-5.

Figure 5-22. Power Supply (A1PS1),  
Schematic Diagram (Sheet 2 of 2)



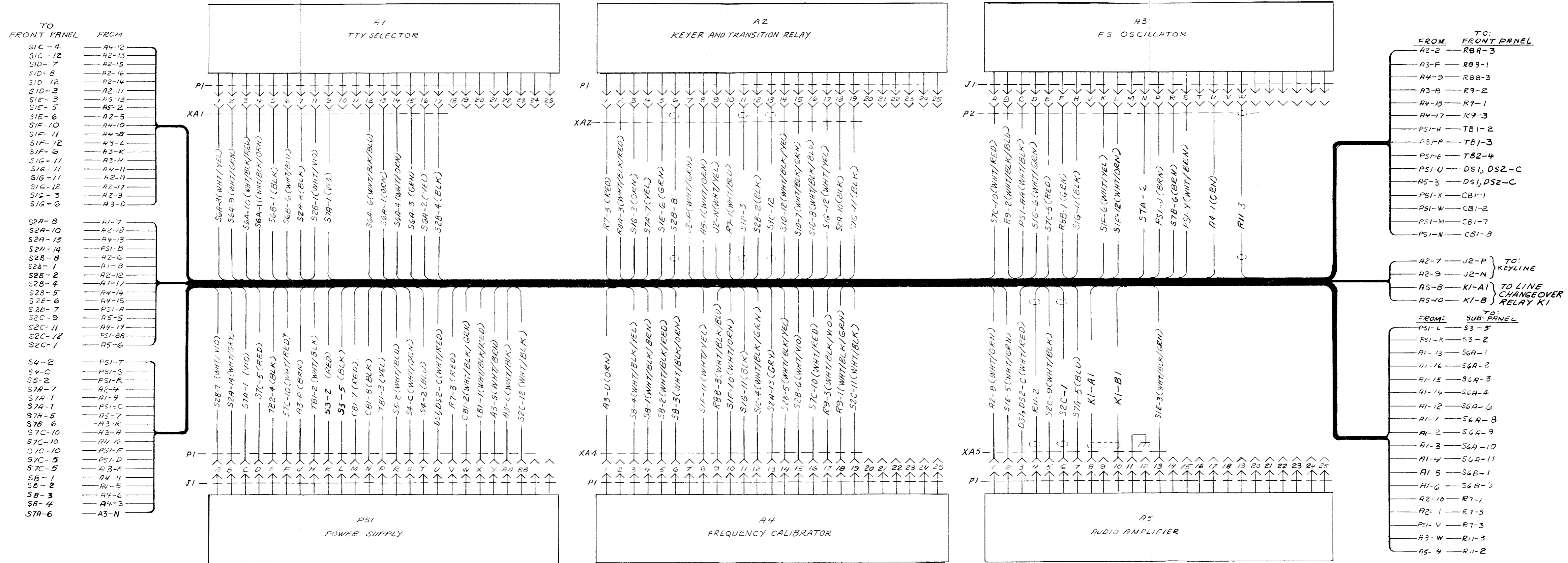
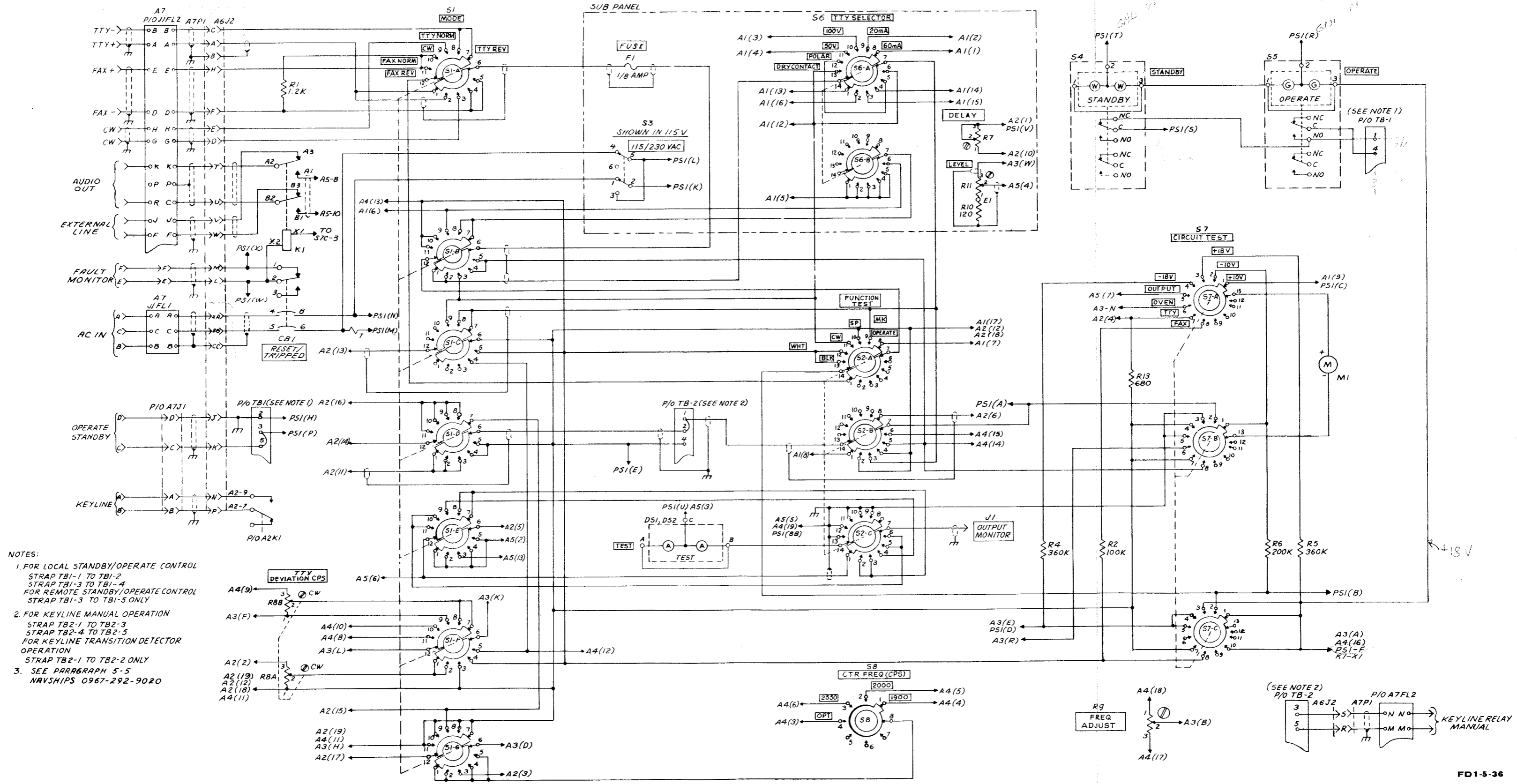

Figure 5-23. Cable Interconnection Diagram (Sheet 1 of 2)

ORIGINAL



- NOTES:
- FOR LOCAL STANDBY/OPERATE CONTROL  
STRAP TBI-1 TO TBI-2  
STRAP TBI-3 TO TBI-4  
FOR REMOTE STANDBY/OPERATE CONTROL  
STRAP TBI-3 TO TBI-5 ONLY
  - FOR KEYLINE MANUAL OPERATION  
STRAP TB2-1 TO TB2-3  
STRAP TB2-4 TO TB2-5  
FOR KEYLINE TRANSITION DETECTOR  
OPERATION  
STRAP TB2-1 TO TB2-2 ONLY
  - SEE PARAGRAPH 5-5  
NAVSHIPS 0967-292-9020

Figure 5-23. Cable Interconnection Diagram  
(Sheet 2 of 2)

SECTION 6  
PARTS LIST

6-1. INTRODUCTION.

This parts list identifies all replaceable assemblies, subassemblies and detail parts of maintenance significance for Keyer, Frequency Shift KY-655/FRT, Part No. E43968G1, manufactured by National Radio Company, Inc., Melrose, Mass. The list is used to facilitate ready identification of components for replacement and ordering purposes. It makes reference to the parts-location Illustrations in Section 5 of this technical manual.

6-2. REFERENCE DESIGNATIONS.

The unit numbering method of assigning reference designations has been used to identify assemblies, subassemblies and parts. This method has been expanded as much as necessary to adequately cover the various degrees of subdivision of the equipment. Partial reference designations have been used to identify piece parts listed within an assembly, subassembly and in Illustrations in Section 5. Complete reference designation may be obtained by prefixing the assembly or subassembly reference designator listed at the top of each page and on Illustrations to the partial reference designation of the piece part. Examples of this unit numbering method and typical expansions of the same are illustrated by the following:

Example 1:

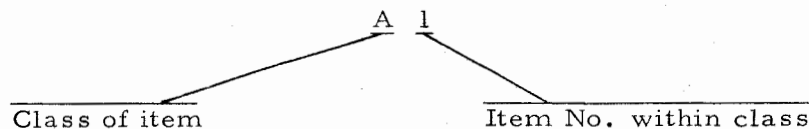

Read as: A1 First (1) assembly of end items. Typical of prefix used at top of page.

Example 2:

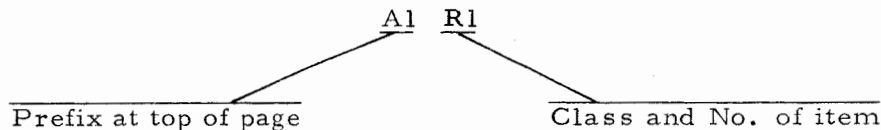

Read as: First (1) resistor (R) of first (1) assembly (A). Top of page prefix A1 added to class and number of Item R1.

Example 3:

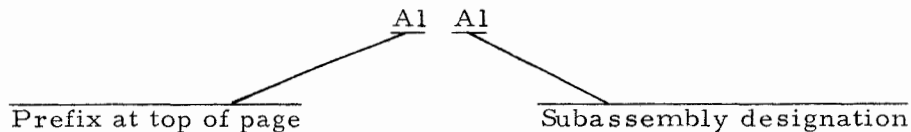

Read as: First (1) subassembly (A) of first (1) assembly (A). Top of page prefix A1 added to subassembly designation A1.

Example 4:



Read as: First (1) resistor (R) of first (1) subassembly (A) of first (1) assembly (A). Top of page prefix A1A1 added to class and number of Item R1.

#### 6-3. LIST OF UNITS.

Table 6-1 is a listing of the units comprising the equipment. The units are listed by their complete reference designation. Table 6-1 contains the following information for each unit listed: (1) reference designation, (2) name and (3) location of the first page of its parts listing in table 6-2.

#### 6-4. MAINTENANCE PARTS LIST.

Table 6-2 lists all assemblies and their maintenance parts. Table 6-2 provides the following information: (1) the complete reference designation by adding the top of the page prefix to the piece part reference designation, (2) name and brief description, and (3) identification of the illustration which pictorially locates the part.

#### 6-5. SPECIAL TOOLS AND EQUIPMENT.

Special tools and equipment supplied with but not part of the equipment are listed at the end of the MAINTENANCE PARTS LIST.

#### 6-6. LIST OF MANUFACTURERS.

Table 6-3 lists the manufacturers of parts used in the equipment. The table includes the manufacturers' code used in table 6-2 to identify the manufacturers. These codes were taken from the Federal Supply Code for Manufacturers, H4-1.

#### 6-7. STOCK NUMBER IDENTIFICATION.

Stock Number Identification Tables (SNIT) and Allowance Parts Lists (APL) issued by Electronics Supply Office (ESO) include Federal Stock Numbers and Source Maintenance and Recoverability Codes. Therefore, reference should be made to the SNIT and APL prepared for this equipment for stock numbering information.

TABLE 6-1. LIST OF UNITS

REF DESIG	NAME	PAGE
	Keyer, Frequency Shift KY-655/FRT	6-4
A1	Printed Circuit Board Subassembly; TTY Selector	6-4
A2	Printed Circuit Board Subassembly; Keyer and Transistor Relay	6-5
A3	Frequency Shift Oscillator Subassembly	6-7
A3A1	Printed Circuit Board Subassembly, Oscillator No. 1	6-8
A3A2	Printed Circuit Board Subassembly, Oscillator No. 2	6-10
A4	Printed Circuit Board Subassembly, Frequency Calibration Board	6-11
A5	Printed Circuit Board Subassembly, Audio Amplifier	6-12
A6	Frequency Shift Keyer Subassembly	6-14
A7	Filter Panel Assembly	6-16
PS1	Power Supply Assembly	6-17
PS1A1	Printed Circuit Board Subassembly, Keyer Relay Control	6-18
PS1A2	Printed Circuit Board Subassembly, 10 Volt Regulator	6-19
PS1A3	Printed Circuit Board Subassembly, 18 Volt Regulator	6-20
PS1A4	Printed Circuit Board Subassembly, Rectifier Filter	6-21

TABLE 6-2. MAINTENANCE PARTS LIST

REF DESIG	NOTES	NAME AND DESCRIPTION	FIG. NO.
		KEYER, FREQUENCY SHIFT KY-655/FRT: A self-contained Power Supply that converts Teletype signals of six types into frequency shift signals over the 250 Hz to 3040 Hz range centered around any one of four preselected center frequencies. The unit also provides CW keying function of 1000 Hz to the Modulator-Oscillator Group and accepts analog input signals converting them into frequency shift signals; 14304 dwg E43968G1.	5-1
A1		PRINTED CIRCUIT BOARD SUBASSEMBLY, TTY SELECTOR: Processes the TTY and CW signals (except polar) received from an external source by converting them into polar keying signals for use by the Transition Relay Assembly; 14304 dwg D44066G1.	5-1
P1		CONNECTOR, PLUG, ELECTRICAL: 25 male contacts, 5 amps 1250 vac RMS, 60 kHz, brass, gold plated finish; 14303 dwg A45175-3; 71468 type DBM 25P.	5-2
R1		RESISTOR: MIL type RN60C1003F.	5-2
R2		RESISTOR: MIL type RN60C4872F.	5-2
R3		RESISTOR: MIL type RC20GF470J.	5-2
R4		Same as R1.	5-2
R5		RESISTOR: MIL type RN60C1503F.	5-2
R6		RESISTOR: MIL type RN60C1470F.	5-2
R7		RESISTOR: MIL type RN60C3011F.	5-2
R8		Same as R7.	5-2
R9		Same as R2.	5-2
R10		Same as R2.	5-2
R11		Same as R2.	5-2
R12		Same as R2.	5-2
R13		RESISTOR: MIL type RN60C3320F.	5-2
R14		RESISTOR: MIL type RN60C2003F.	5-2
R15		Same as R2.	5-2
R16		Same as R2.	5-2
R17		Same as R2.	5-2
R18		Same as R2.	5-2
R19		RESISTOR: MIL type RN60C1871F.	5-2
R20		RESISTOR: MIL type RT22C2P201.	5-2

TABLE 6-2. MAINTENANCE PARTS LIST (Cont)

REF DESIG	NOTES	NAME AND DESCRIPTION	FIG. NO.
A2		PRINTED CIRCUIT BOARD SUBASSEMBLY, KEYER AND TRANSITION RELAY: Two functionally related circuits mounted on one printed circuit board. The unit amplifies the polar signals received from the TTY selector, and supplies the correct signal level to drive the frequency shift oscillator. The unit also provides a key-line closure to the Modulator-Synthesizer upon receipt of a polar keying signal from the TTY selector; 14304 dwg D43986G1.	5-1
C1		CAPACITOR: MIL type CK05CW102K.	5-3
C2		CAPACITOR: MIL type CK05CW681K.	5-3
C3		CAPACITOR: MIL type CK06CW103K.	5-3
C4		Same as C2.	5-3
C5		CAPACITOR: MIL type CS13BF156K.	5-3
C6		Same as C3.	5-3
CR1		SEMICONDUCTOR: MIL type 1N914.	5-3
CR2		SEMICONDUCTOR: MIL type 1N963B.	5-3
CR3		Same as CR1.	5-3
CR4		Same as CR1.	5-3
CR5		Not used.	
CR6		Same as CR1.	5-3
CR7		SEMICONDUCTOR: MIL type 1N483B.	5-3
K1		RELAY, ARMATURE: Double pole normally open; 0.5 amp, 250 vdc; 42498 dwg A44195-1; 12965 type MG-2A.	5-3
L1		COIL, RF: MIL type MS90537-53.	5-3
P1		CONNECTOR, PLUG, ELECTRICAL: 25 male contacts, 5 amps 1250 vac RMS, 60 kHz, brass, gold plated finish; rectangular, cadmium plated w/yellow chromate finish; 14304 dwg A45175-3; 71468 type DBM25P.	5-3
Q1		TRANSISTOR: MIL type 2N2222.	5-3
Q2		TRANSISTOR: MIL type 2N3822.	5-3
Q3		TRANSISTOR: MIL type 2N706.	5-3
Q4 thru Q6		Same as Q3.	5-3
Q7		TRANSISTOR: MIL type 2N2323A.	5-3
Q8		Same as Q3.	5-3
Q9		TRANSISTOR: MIL type 2N491A.	5-3
Q10		Same as Q1.	5-3
Q11		Same as Q3.	5-3
Q12		Same as Q1.	5-3
Q13		Same as Q1.	5-3
R1		RESISTOR: MIL type RC07GF681K.	5-3
R2		RESISTOR: MIL type RC07GF561K.	5-3
R3		RESISTOR: MIL type RC07GF104K.	5-3
R4		RESISTOR: MIL type M22684-03-0097.	5-3
R5		RESISTOR: MIL type RT22C2W202.	5-3
R6		RESISTOR: MIL type RB55CE18700F.	5-3
R7		RESISTOR: MIL type RB55CE46400F.	5-3
R8		Same as R5.	5-3
R9		RESISTOR: MIL type RB55CE43200F.	5-3
R10		RESISTOR: MIL type RC07GF684K.	5-3

TABLE 6-2. MAINTENANCE PARTS LIST (Cont)

REF DESIG	NOTES	NAME AND DESCRIPTION	FIG. NO.
A2 (cont)			
R11		RESISTOR: MIL type RC07GF103K.	5-3
R12		RESISTOR: MIL type RC07GF474K.	5-3
R13		RESISTOR: MIL type RC07GF393J.	5-3
R14		Same as R5.	5-3
R15		RESISTOR: MIL type RC07GF271K.	5-3
R16		RESISTOR: MIL type RC07GF153K.	5-3
R17		Same as R16.	5-3
R18		Same as R15.	5-3
R19		RESISTOR: MIL type RC07GF682K.	5-3
R20		RESISTOR: MIL type RC07GF682J.	5-3
R21		Same as R13.	5-3
R22		RESISTOR: MIL type RC07GF391K.	5-3
R23		RESISTOR: MIL type RC07GF822K.	5-3
R24		Same as R15.	5-3
R25		RESISTOR: MIL type RC07GF182K.	5-3
R26		Same as R19.	5-3
R27		Same as R11.	5-3
R28		RESISTOR: MIL type RC07GF122K.	5-3
R29		RESISTOR: MIL type RC07GF101K.	5-3
R30		<b>RESISTOR: MIL type RC07GF572K</b>	5-3
R31		<b>Same as R30.</b>	5-3
R32		Same as R1.	5-3
R33		Same as R25.	5-3
R34		RESISTOR: MIL type RC07GF471K.	5-3
R35		RESISTOR: MIL type RC07GF222K.	5-3
R36		RESISTOR: MIL type RC07GF472K.	5-3
R37		Same as R25.	5-3
R38		Same as R11.	5-3
R39		RESISTOR: MIL type RC07GF181K.	5-3
R40		Same as R11.	5-3
R41		Same as R35. (Not shown)	



TABLE 6-2. MAINTENANCE PARTS LIST (Cont)

REF DESIG	NOTES	NAME AND DESCRIPTION	FIG. NO.
A3		<p>FREQUENCY SHIFT OSCILLATOR SUBASSEMBLY: Oscillators are mounted in a temperature controlled oven assembly; two voltage controlled, high stability crystal oscillators perform the following functions: 1. one oscillator determines the centre frequency, 2. the second oscillator determines the degree of frequency shift; the difference in frequency between the two oscillators is the output frequency of the keyer, 14304 dwg D44866G1.</p>	5-1
Z1		<p>OVEN, OSCILLATOR: 28 vdc input voltage; 1.0 amp max input current; 500 MW max internal power dissipation; 4 hours max warm-up time; 14304 dwg A44362-1; 82567 type V12448.</p>	5-4

TABLE 6-2. MAINTENANCE PARTS LIST (Cont)

REF DESIG	NOTES	NAME AND DESCRIPTION	FIG. NO.
A3A1		PRINTED CIRCUIT BOARD SUBASSEMBLY, FREQUENCY SHIFT OSCILLATOR NO. 1: 14304 dwg D44424G1.	5-4
C1		CAPACITOR: MIL type CK06CW103K.	5-5
C2 thru C4		Same as C1.	5-5
C5		CAPACITOR: MIL type CK05CW102K.	5-5
C6		Same as C1.	5-5
C7		Same as C5.	5-5
C8		Same as C5.	5-5
C9		Same as C5.	5-5
C10		CAPACITOR: MIL type CM05FC221JP3.	5-5
C11		CAPACITOR: MIL type CM06FC681JP3.	5-5
C12		Same as C5.	5-5
C13		Same as C5.	5-5
C14		Same as C1.	5-5
C15		Same as C10.	5-5
C16		Same as C11.	5-5
C17		Same as C1.	5-5
C18		CAPACITOR: MIL type CC20CJ2R2C.	5-5
C19		CAPACITOR: MIL type CM05FC050JP3.	5-5
C20		Same as C5.	5-5
C21		CAPACITOR: MIL type CK05CW101K.	5-5
C22		Same as C5.	5-5
C23		Same as C5.	5-5
C24		Same as C21.	5-5
C25		CAPACITOR: MIL type CM05FC331JP3.	5-5
C26		CAPACITOR: MIL type CM05FC121JP3.	5-5
C27		Same as C5.	5-5
C28		Same as C5.	5-5
C29		Same as C5.	5-5
C30		Same as C1.	5-5
C31		Same as C5.	5-5
C32		Same as C1.	5-5
C33		Same as C5.	5-5
C34		Same as C1.	5-5
CR1		SEMICONDUCTOR: MIL type 1N823.	5-5
CR2		SEMICONDUCTOR: MIL type 1N943B.	5-5
CR3		Same as CR1.	5-5
CR4		VARACTOR: MIL type 1N4804B.	5-5
CR5		VARACTOR: MIL type 1N4808B.	5-5
CR6		Same as CR4.	5-5
CR7		SEMICONDUCTOR: MIL type 1N914.	5-5
CR8		Same as CR7.	5-5
L1		COIL, RF: MIL type MS90537-37.	5-5
L2		Same as L1.	5-5
L3		COIL, RF: 10 uh, Q46 at 2.5 MHz, 480 ma, 1.4 ohms dc resistance; 14304 dwg A46248-1; 43543 type WEEVL10.	5-5
L4		COIL, RF: MIL type MS90537-21.	5-5
L5		Same as L3.	5-5
L6		COIL, RF: MIL type MS90537-23.	5-5
L7		Same as L1.	5-5
L8		Same as L1.	5-5
L9		Same as L1.	5-5

TABLE 6-2. MAINTENANCE PARTS LIST (Cont)

REF DESIG	NOTES	NAME AND DESCRIPTION	FIG. NO.
A3A1 (cont)			
L10		COIL, RF: MIL type MS90537-25.	5-5
L11		Same as L1.	5-5
L12		COIL, RF: MIL type MS90537-33.	5-5
L13		Same as L12.	5-5
L14		COIL, RF: MIL type MS90537-49.	5-5
Q1		TRANSISTOR: MIL type 2N918.	5-5
Q2		Same as Q1.	5-5
Q3		TRANSISTOR: MIL type 2N2222.	5-5
Q4		Same as Q3.	5-5
Q5		Same as Q3.	5-5
Q6		Same as Q3.	5-5
R1		RESISTOR: MIL type RC07GF821K.	5-5
R2		RESISTOR: MIL type RC07GF561K.	5-5
R3		RESISTOR: MIL type <b>RC07GF272J</b> .	5-5
R4		RESISTOR: MIL type RJ22CW253.	5-5
R5		RESISTOR: MIL type RC07GF473K.	5-5
R6		RESISTOR: MIL type RC07GF272J.	5-5
R7		RESISTOR: MIL type RC07GF472J.	5-5
R8		Same as R6.	5-5
R9		Same as R7.	5-5
R10		Same as R5.	5-5
R11		Same as R5.	5-5
R12		Same as R5.	5-5
R13		Same as R5.	5-5
R14		RESISTOR: MIL type RC07GF104K.	5-5
R15		RESISTOR: MIL type RC07GF682K.	5-5
R16		RESISTOR: MIL type RC07GF103K.	5-5
R17		Same as R15.	5-5
R18		Same as R16.	5-5
R19		RESISTOR: MIL type RC07GF152K.	5-5
R20		Same as R19.	5-5
R21		Same as R15.	5-5
R22		Same as R16.	5-5
R23		Same as R15.	5-5
R24		Same as R16.	5-5
R25		RESISTOR: MIL type RC07GF122K.	5-5
R26		Same as R25.	5-5
R27		Same as R2.	5-5
Y1, Y2		CRYSTAL UNIT, QUARTZ: 10,000 MHz porm .001 pct frequency tolerance; plus 75 deg C to plus 85 deg C operating temp. range; matched pair; 42498 dwg A44197-1.	5-5
Z1		MIXER, RF: 50 ohms impedance; F1 input 10 MHz, F2 input 10 MHz, F3 output 0-3 kHz; 42498 dwg A42962-2.	5-5

TABLE 6-2. MAINTENANCE PARTS LIST (Cont)

REF DESIG	NOTES	NAME AND DESCRIPTION	FIG. NO.
A3A2		PRINTED CIRCUIT BOARD SUBASSEMBLY, FREQUENCY SHIFT OSCILLATOR NO. 2: 14304 dwg D44418G1.	5-4
CR1		SEMICONDUCTOR: Silicon; glass hermetically sealed; 0.096 in. dia by 0.265 in. lg excl wire leads; 14304 dwg A47751-1; 16352 type LD117.	5-6
Q1		TRANSISTOR: MIL type 2N2222.	5-6
R1		RESISTOR: MIL type RC07GF273J.	5-6
R2		RESISTOR: MIL type RC07GF183J.	5-6
R3		RESISTOR: MIL type RC07GF560J.	5-6
R4		Same as R2.	5-6
R5		RESISTOR: MIL type RT22C2P202.	5-6
R6		Not used.	5-6
R7		RESISTOR: MIL type RC07GF272J.	5-6
R8		Same as R3.	5-6
R9		RESISTOR: MIL type RC07GF271J.	5-6

TABLE 6-2. MAINTENANCE PARTS LIST (Cont)

REF DESIG	NOTES	NAME AND DESCRIPTION	FIG. NO.
A4		PRINTED CIRCUIT BOARD SUBASSEMBLY, FREQUENCY CALIBRATION BOARD: Provides all required voltage levels for setting the centre fre- quencies of the keyer; the "fax" input signal processing circuitry is also part of the frequency calibration subassembly; 14304 dwg D44225G1.	5-1
P1		CONNECTOR, PLUG, ELECTRICAL: 25 male con- tacts, 5 amps, 1250 vac RMS, 60 kHz, brass, gold plated finish rectangular, steel, cadmium plated w/yellow chromate finish; 14304 dwg A45175-3; 71468 type DBM25P.	5-7
R1		RESISTOR: MIL type RB55CE82500F.	5-7
R2		RESISTOR: MIL type RB55CE18700F.	5-7
R3		RESISTOR: MIL type RB55CE12100F.	5-7
R4		RESISTOR: MIL type RB55CE15000F.	5-7
R5		Same as R4.	5-7
R6		RESISTOR: MIL type RB55CE47500F.	5-7
R7		RESISTOR: MIL type RB55CE200R0F.	5-7
R8		RESISTOR: MIL type RB55CE27400F.	5-7
R9		RESISTOR: MIL type RT22C2W202.	5-7
R10		RESISTOR: MIL type RB55CE10001F.	5-7
R11		Same as R9.	5-7
R12		RESISTOR: MIL type RT22C2W501.	5-7
R13		Same as R12.	5-7
R14		Same as R12.	5-7
R15		Same as R12.	5-7
R16		Same as R12.	5-7
R17		Same as R12.	5-7
R18		RESISTOR: MIL type RB55CE22101F.	5-7
R19		RESISTOR: MIL type RB55CE20000F.	5-7
R20		Same as R3.	5-7
R21		RESISTOR: MIL type RT22C2P502.	5-7
R22		RESISTOR: MIL type RB55CE56200F.	5-7
R23		RESISTOR: MIL type RB55CE64900F.	5-7
R24		RESISTOR: MIL type RB55CE11001F.	5-7
R25		Same as R23.	5-7
R26		Same as R22.	5-7
R27		RESISTOR: MIL type RB55CE43200F.	5-7
R28		Same as R3.	5-7

TABLE 6-2. MAINTENANCE PARTS LIST (Cont)

REF DESIG	NOTES	NAME AND DESCRIPTION	FIG. NO.
A5		PRINTED CIRCUIT BOARD SUBASSEMBLY, AUDIO AMPLIFIER: Circuitry raises output of the frequency shift oscillator to the required system level; 14304 dwg D44274G1.	5-1
C1		CAPACITOR: MIL type CL65BH151MP3.	5-8
C2		Same as C1.	5-8
C3		Same as C1.	5-8
C4		CAPACITOR: MIL type CK06CW103K.	5-8
C5		Same as C1.	5-8
C6		CAPACITOR: MIL type CK06BX223K.	5-8
C7		Same as C1.	5-8
C8		CAPACITOR: MIL type CS13BB157K.	5-8
C9		CAPACITOR: MIL type CK06BX333K.	5-8
C10		Same as C1.	5-8
CR1		SEMICONDUCTOR: MIL type 1N914.	5-8
P1		CONNECTOR, PLUG, ELECTRICAL: 25 male contacts, 5 amps, 1250 vac RMS, 60 kHz, brass, gold plated finish; rectangular, steel cadmium plated w/yellow chromate finish; 14304 dwg A45175-3; 71468 type DBM25P.	5-8
Q1		TRANSISTOR: MIL type 2N2222.	5-8
Q2		Same as Q1.	5-8
Q3		Same as Q1.	5-8
Q4		Same as Q1.	5-8
Q5		Same as Q1.	5-8
Q6		Same as Q1.	5-8
R1		RESISTOR: MIL type RC07GF273K.	5-8
R2		RESISTOR: MIL type RC07GF272K.	5-8
R3		RESISTOR: MIL type RC20GF621K.	5-8
R4		RESISTOR: MIL type RC07GF123K.	5-8
R5		RESISTOR: MIL type RC07GF222K.	5-8
R6		RESISTOR: MIL type RC07GF151K.	5-8
R7		RESISTOR: MIL type RC07GF184K.	5-8
R8		RESISTOR: MIL type RC07GF122K.	5-8
R9		Same as R6.	5-8
R10		Same as R1.	5-8
R11		Same as R5.	5-8
R12		RESISTOR: MIL type RC07GF153K.	5-8
R13		RESISTOR: MIL type RC07GF182K.	5-8
R14		RESISTOR: MIL type RC07GF121K.	5-8
R15		RESISTOR: MIL type RC07GF332J.	5-8
R16		RESISTOR, VARIABLE: Non-wirewound; 5,000 ohms, porm 20 pct, 0.5 w; 14304 dwg A42564-1; 80740 type 61M5K.	5-8
R17		Same as R15.	5-8
R18		RESISTOR: MIL type RC07GF821J.	5-8
R19		RESISTOR: MIL type RC07GF103K.	5-8
R20		RESISTOR: MIL type RC07GF681K.	5-8
R21		Same as R19.	5-8
R22		RESISTOR: MIL type RC07GF562J.	5-8
R23		Same as R8.	5-8
R24		RESISTOR: MIL type RC07GF181K.	5-8
R25		Same as R8.	5-8

TABLE 6-2. MAINTENANCE PARTS LIST (Cont)

REF DESIG	NOTES	NAME AND DESCRIPTION	FIG. NO.
A5(cont) T1		TRANSFORMER, AUDIO FREQUENCY: 50 MW; 600 ohms center tapped primary and secondary impedance rating; 3 ma primary and secondary dc current rating; 72 ohms primary dc resistance, 92 ohms secondary dc resistance; 42498 dwg A46244-1; 81095 type SP67.	

REF DESIG	NOTES	NAME AND DESCRIPTION	FIG. NO.
A6		FREQUENCY SHIFT KEYSUBASSEMBLY: All the electronic subassemblies used in the keyer are mounted on the main chassis and front panel assembly; all subassemblies plug into multipin connectors which are part of the main chassis harness; connecting the individual module connectors to the front panel, and to the interface connector mounted on the rear of the main chassis; 42498 dwg E43921G 1.	5-1
CB1		CIRCUIT BREAKER: SPDT; 1.0 amp, 240 vac, 60 cps; 42498 dwg A44733-3; 81541 type AP13SR199-3.	5-1
DS1		LAMP, INCAND: 18 vdc, 0.04 amp; T-1 3/4 bulb; 42498 dwg A46155-2; 24446 type 370.	5-1
DS2 thru DS6		Same as DS1.	5-1
F1		FUSE: MIL type F02A250V1-8A.	5-1
F2		FUSE: MIL type FM03-1-8A.	5-1
J1		CONNECTOR, RECEPTACLE, ELECTRICAL: 1 female contact, 1 amp, 50 ohms impedance, 500 vdc, phospher bronze; straight shape, brass, silver plated finish; 42498 dwg A44259-1; 74868 type 17825.	5-1
J2		CONNECTOR, RECEPTACLE, ELECTRICAL: 26 male contacts, 13 amps, phospher bronze, gold plated finish; rectangular, plastic; 42498 dwg A42559-3; 81312 type MRAC26PG7.	5-1
K1		RELAY: MIL type M5757-9-003. (Not shown)	5-1
M1		AMMETER: 0 to 100 ua range of inscription; porm 3 pct accuracy at full scale deflection; white background w/black and green markings; 42498 dwg A44050-1; 11707 type 59.8076.	5-1

TABLE 6-2. MAINTENANCE PARTS LIST (Cont)

REF DESIG	NOTES	NAME AND DESCRIPTION	FIG. NO.
A6(cont.)		<b>FREQUENCY SHIFT KEYS SUBASSEMBLY</b>	5-1
MP1		<b>KNOB: MIL type MS91528-1K2B.</b>	5-1
MP2 thru MP5		Same as MP1.	5-1
MP6		Not used.	
MP7		<b>COUNTER, DIAL: In-line digital readout (3 digit display) 000 to 999 to 10 turns of control knob; 1 turn displays readout of 100 in increments of tenths; CW rotation; 42498 dwg A45881-1; 96791 type 1309BS896100.</b>	5-1
MP8		<b>Slide Assy, Right Hand: Aluminum Channels and lockarms, aluminum anodized finish; cadmium plated cres components; 42498 dwg A44599-5.</b>	5-1
MP9		<b>Slide Assy, Left Hand: Aluminum Channels and lockarms, aluminum anodized finish; cadmium plated cres components; 42498 dwg A44599-6</b>	5-1
P1		<b>CONNECTOR, RECEPTACLE, ELECTRICAL: 26 female contacts, 13 amps, phospher bronze, gold plated finish; rectangular, plastic; 42498 dwg A42560-3; 81312 type MRAC26SG7.</b>	5-1
P2		<b>CONNECTOR: MIL type MS18177-1.</b>	5-1
R1		<b>RESISTOR: MIL type RC07GF122J.</b>	5-1
R2		<b>RESISTOR: MIL type RC07GF104J.</b>	5-1
R3		Not used.	
R4		<b>RESISTOR: MIL type RC07GF364J.</b>	5-1
R5		Same as R4.	5-1
R6		<b>RESISTOR: MIL type RC07GF204J.</b>	5-1
R7		<b>RESISTOR: MIL type RV4SAYS504C.</b>	5-1
R8		<b>RESISTOR: VARIABLE: Wirewound; dual; 10 turn; 1,000 ohms, porm 3 pct, 2 w each section; 42498 dwg A44059-1; 80294 type 3500-135-102/102.</b>	5-1
R9		<b>RESISTOR, VARIABLE: Lead screw actuated; 25 turn; 2,000 ohms, porm 10 pct, 0.5 w at plus 70 deg C; 42498 dwg A44057-1; 80294 type 3052S1-202M.</b>	5-1



TABLE 6-2. MAINTENANCE PARTS LIST (Cont)

REF DESIG	NOTES	NAME AND DESCRIPTION	FIG. NO.
A6 (cont)			
R10		RESISTOR: MIL type RC07GF121J.	5-1
R11		RESISTOR: MIL type RV4LAYSAl02C.	5-1
R12		Not used.	
R13		RESISTOR: MIL type RC07GF681J.	5-1
S1		SWITCH, ROTARY: 7 sections, 2 poles and 5 positions for each section; nonshorting contacts; 30 deg positioning increment; 14304 dwg A44700-1; 76854 type 267633A7.	5-1
S2		SWITCH, ROTARY: 3 sections, 2 poles and 6 positions for each section; nonshorting contacts; 30 deg positioning increment; 14304 dwg A44692-1; 76854 type 267632A3.	5-1
S3		SWITCH: MIL type MS35059-23.	5-1
S4		SWITCH, PUSH: 2 PDT; 3 amps, 28 vdc; 14304 dwg A44044-27; 96182 type 90E10A1C2J1(W)H1L10N1R12 STANDBY.	5-1
S5		SWITCH, PUSH: 2 PDT; 3 amps, 28 vdc; 14304 dwg A44044-26; 96182 type 90E10A1C2J1(G)H1L10N1R12 OPERATE.	5-1
S6		Same as S2.	5-1
S7		SWITCH, ROTARY: 3 sections, 1 pole and 12 positions for each section; nonshorting contacts; 30 deg positioning increment; 14304 dwg A44683-1; 76854 type 267631A3.	5-1
S8		SWITCH, ROTARY: 1 section, 1 pole and 4 positions; nonshorting contacts; 45 deg positioning increment; 14304 dwg A44706-1; 76854 type 267634AA1.	5-1
TB1		TERMINAL BOARD: MIL type 37TB5.	5-1
TB2		Same as TB1.	5-1
XA1		CONNECTOR, RECEPTACLE, ELECTRICAL: 25 female contacts, 5 amps, 1250 vac RMS, copper, gold plated finish; rectangular, steel, cadmium plated finish; 14304 dwg A45176-3; 71468 type DBMF25S.	5-1
XA2		Same as XA1.	5-1
XA3		Not used.	
XA4		Same as XA1.	5-1
XA5		Same as XA1.	5-1
XDS1		LIGHT, INDICATOR: 1 amp, filter color amber; marked "TEST"; 14304 dwg A44045-22; 96182 type 80E10A1F1(A)H1J11L1N12 TEST.	5-1
XF1		FUSEHOLDER: MIL type FHN20G.	5-1
XF2		FUSEHOLDER: Rectangular; molded bakelite base; 0.625 in. h by 0.500 in. w by 1.625 in. lg o/a; 14304 dwg A46064-1; 71400 type 4574.	5-1

TABLE 6-2. MAINTENANCE PARTS LIST (Cont)

REF DESIG	NOTES	NAME AND DESCRIPTION	FIG. NO.
A7		<p><b>FILTER PANEL ASSEMBLY:</b> The filter assembly used by the keyer is mounted on the rear panel of the outer cabinet; two RF filter subassemblies are part of the panel along with the multi-pin connectors required for interfacing with external apparatus; the cable connecting the main chassis and the filters is part of the filter assembly, providing input, output signals and power connections are required by the keyer; 42498 dwg E44636G1.</p>	5-1
FL1		<p><b>FILTER, RADIO INTERFERENCE:</b> 250 vac or 600 vdc, 2 x 1.5 amps; 42498 dwg A44196-1; 13619 type RF2890-3.</p>	5-1
FL2		<p><b>FILTER, RADIO INTERFERENCE:</b> 12 active; 250 vdc, 0.1 amp at plus 25 deg C for each section; 42498 dwg A44859-1.</p>	5-1
J1 P1		<p><b>CONNECTOR:</b> MIL type MS3114E12-10PX. <b>CONNECTOR, PLUG, ELECTRICAL:</b> 26 female contacts, 13 amps, phospher bronze, gold plated finish; rectangular, plastic; 42498 dwg A42560-3; 81312 type MRAC26SG7.</p>	5-1
MP1		<p><b>Cable, Ribbon:</b> no. 24AWG; 10 twisted, shielded pair; 1 black and 1 white conductor, teflon jacket; 42498 dwg A46099-7</p>	5-1

TABLE 6-2. MAINTENANCE PARTS LIST (Cont)

REF DESIG	NOTES	NAME AND DESCRIPTION	FIG. NO.
PS1		POWER SUPPLY ASSEMBLY: Consists of six functionally related circuits; a common transformer and rectifier assembly; two plus 18 volt dc regulators; plus 10 volt dc regulator; minus 10 volt dc regulator; 28 volt dc oven supply and a relay control circuit; the power supply assembly supplies all operating voltages for the keyer from a 110/220 vac 60 cps source; 14304 dwg E44188G1.	5-1
CR1		SEMICONDUCTOR: MIL type 1N1124A.	5-9
CR2		Same as CR1.	5-9
J1		CONNECTOR, RECEPTACLE, ELECTRICAL: 26 male contacts, 13 amps, phospher bronze, gold plated finish; rectangular, plastic; 14304 dwg A42559-3; 81312 type MRAC26PG7.	5-9
L1		CHOKE, RF: 100 mh, 0.2 amp, 55 vdc; 14304 dwg A44727-2.	5-9
L2		Same as L1.	5-9
L3		CHOKE, RF: 150 mh, 0.2 amp, and 30 mh, 1.0 amp, 55 vdc; 14304 dwg A44727-1.	5-9
Q1		TRANSISTOR: MIL type 2N2219.	5-9
Q2		Same as Q1.	5-9
Q3		TRANSISTOR: MIL type 2N1485.	5-9
Q4		Same as Q3.	5-9
R1		RESISTOR: MIL type RW68V151.	5-9
T1		TRANSFORMER, POWER, STEP-UP: Primary winding 115 and 230 vac, 47 to 63 cps, single phase; secondary windings no. 1 and 2 tapped at 50 v, 0.02 amp dc; secondary windings no. 3 and 4 tapped at 68 v, 0.3 amp dc and secondary winding no. 5 tapped at 70 v, 1.2 amps dc; 14304 dwg A44778-1.	5-9



TABLE 6-2. MAINTENANCE PARTS LIST (Cont)

REF DESIG	NOTES	NAME AND DESCRIPTION	FIG. NO.
PS1A2		PRINTED CIRCUIT BOARD SUBASSEMBLY, 10 VOLT REGULATOR: Provides $\pm 10$ vdc with floating return to the Keyer and Transition Relay module (A2); 14304 dwg D44266G1.	5-9
C1		CAPACITOR: MIL type CK05CW121K.	5-11
C2		Same as C1.	5-11
C3		CAPACITOR: MIL type CS13BE155K.	5-11
C4		Same as C3.	5-11
C5		CAPACITOR: MIL type CS13BE476K.	5-11
C6		Same as C5.	5-11
C7		CAPACITOR: MIL type M18312-01-0436.	5-11
C8		Same as C7.	5-11
CR1		SEMICONDUCTOR: MIL type 1N754A.	5-11
CR2		Same as CR1.	5-11
CR3		SEMICONDUCTOR: MIL type 1N914.	5-11
CR4		Same as CR3.	5-11
CR5		Same as CR3.	5-11
CR6		Same as CR3.	5-11
CR7		SEMICONDUCTOR: MIL type 1N823.	5-11
CR8		Same as CR7.	5-11
Q1		TRANSISTOR: MIL type 2N2222.	5-11
Q2		Same as Q1.	5-11
Q3		Same as Q1.	5-11
Q4		Same as Q1.	5-11
Q5		Same as Q1.	5-11
Q6		Same as Q1.	5-11
R1		RESISTOR: MIL type RC07GF202K.	5-11
R2		RESISTOR: MIL type RC07GF103K.	5-11
R3		Same as R1.	5-11
R4		Same as R2.	5-11
R5		RESISTOR: MIL type RC07GF180K.	5-11
R6		Same as R5.	5-11
R7		RESISTOR: MIL type RC07GF331K.	5-11
R8		Same as R7.	5-11
R9		RESISTOR: MIL type RC07GF682J.	5-11
R10 thru R14		Same as R9.	5-11
R15		RESISTOR: MIL type RN55D2741F.	5-11
R16		RESISTOR: MIL type RT12C2P502.	5-11
R17		RESISTOR: MIL type RN55D6811F.	5-11
R18		Same as R15.	5-11
R19		Same as R16.	5-11
R20		Same as R17.	5-11

TABLE 6-2. MAINTENANCE PARTS LIST (Cont)

REF DESIG	NOTES	NAME AND DESCRIPTION	FIG. NO.
PS1A3		PRINTED CIRCUIT BOARD SUBASSEMBLY, ±18 VOLT REGULATOR: Provides +18 vdc with grounded return and +18 vdc with floating return to the TTY Selector (A1) and FS Oscillator (A3) modules; 14304 dwg D44265G1.	5-9
C1		CAPACITOR: MIL type CK05CW121K.	5-12
C2		Same as C1.	5-12
C3		CAPACITOR: MIL type CS13BE155K.	5-12
C4		Same as C3.	5-12
C5		CAPACITOR: MIL type CS13BF476K.	5-12
C6		Same as C5.	5-12
C7		CAPACITOR: MIL type M18312-01-0436.	5-12
CR1		SEMICONDUCTOR: MIL type 1N758A.	5-12
CR2		Same as CR1.	5-12
CR3		SEMICONDUCTOR: MIL type 1N914.	5-12
CR4		Same as CR3.	5-12
CR5		Same as CR3.	5-12
CR6		Same as CR3.	5-12
CR7		SEMICONDUCTOR: MIL type 1N823.	5-12
CR8		Same as CR7.	5-12
Q1		TRANSISTOR: MIL type 2N2222.	5-12
Q2		Same as Q1.	5-12
Q3		Same as Q1.	5-12
Q4		Same as Q1.	5-12
Q5		Same as Q1.	5-12
Q6		Same as Q1.	5-12
R1		RESISTOR: MIL type RC07GF821K.	5-12
R2		RESISTOR: MIL type RC07GF153K.	5-12
R3		Same as R1.	5-12
R4		Same as R2.	5-12
R5		RESISTOR: MIL type RW69V1R0.	5-12
R6		Same as R5.	5-12
R7		RESISTOR: MIL type RC07GF152K.	5-12
R8		Same as R7.	5-12
R9		RESISTOR: MIL type RC07GF153K.	5-12
R10		Same as R9.	5-12
R11		RESISTOR: MIL type RC07GF682K.	5-12
R12		Same as R11.	5-12
R13		Same as R9.	5-12
R14		Same as R9.	5-12
R15		RESISTOR: MIL type RN55D1542F.	5-12
R16		RESISTOR: MIL type RT12C2P502.	5-12
R17		RESISTOR: MIL type RN55D6811F.	5-12
R18		Same as R15.	5-12
R19		Same as R16.	5-12
R20		Same as R17.	5-12

TABLE 6-2. MAINTENANCE PARTS LIST (Cont)

REF DESIG	NOTES	NAME AND DESCRIPTION	FIG. NO.
PS1A4  C1 C2 thru C4 C5 C6 CR1 CR2 CR3 CR4 CR5 CR6 CR7 CR8 R1 R2 R3 R4		PRINTED CIRCUIT BOARD SUBASSEMBLY, RECTIFIER FILTER: Provides +21 vdc to the Keyer and Transition Relay module (A2), and -30 vdc to the FS Oscillator module (A3); 14304 dwg D44248G1. CAPACITOR: MIL type CL65BH151MP3. Same as C1. CAPACITOR: MIL type M39018-03-0148. Same as C5. SEMICONDUCTOR: MIL type 1N645. Same as CR1. Same as CR1. Same as CR1. Same as CR1. Same as CR1. Same as CR1. Same as CR1. Same as CR1. Same as CR1. RESISTOR: MIL type RC32GF151K. Same as R1. Same as R1. Same as R1.	5-9  5-13

TABLE 6-2. MAINTENANCE PARTS LIST (Cont)

REF DESIG	NOTES	NAME AND DESCRIPTION	FIG. NO.
		<p>SUPPLIED WITH BUT NOT PART OF EQUIPMENT</p> <p>SPECIAL TOOL AND EQUIPMENT</p> <p>CABLE ASSEMBLY, SPECIAL PURPOSE, ELECTRICAL: C/o one connector plug MIL type MS3116E12-10S on one end and one connector plug MIL type MS3116E12-10SX on the other end; 7 ft. lg hook-up wire housed in conduit assembly; 42498 dwg D45336G1.</p> <p>CONNECTOR: MIL type MS3108R14S7S.</p> <p>CONNECTOR: MIL type <b>MS3116F14-15SW</b>.</p> <p>CABLE ASSEMBLY, SPECIAL PURPOSE, ELECTRICAL: C/o one connector plug MIL type MS18176-1 on one end and one connector plug MIL type MS18177-1 on the other end; 42498 dwg C45629G1.</p> <p>CABLE ASSEMBLY, SPECIAL PURPOSE, ELECTRICAL: C/o one connector plug Cannon Electric Co. type DBM25P on one end and one con- nector plug Cannon Electric Co. type DBMF25S on the other end; 42498 dwg C45630G1.</p>	



TABLE 6-3. LIST OF MANUFACTURERS

MFR CODE	NAME	ADDRESS
11707	Ideal Precision Meter Co., Inc.	214 Franklin Street Brooklyn, N. Y. 11222
12965	Computer Components, Inc.	88-06 Van Wyck Express Way Jamaica, N. Y. 11418
30463	Breeze-Illinois, Inc.	Wyoming, Ill. 61491
14304	RF Communications, Inc.	1680 University Avenue, Rochester, New York, 14610
43543	Nytronics, Inc. Transformer Co. Div.	Third Avenue Alpha, N. J. 08866
71400	Bussmann Mfg. Div. of McGraw-Edison Co.	2536 W. University Street St. Louis, Mo. 63017
71468	ITT Cannon Electric, Inc.	3208 Humbolt Street Los Angeles, Calif. 90031
74868	Amphenol Corp. Amphenol RF Div.	33 E. Franklin Street Danbury, Conn. 06810
76854	Oak Mfg. Co.	S. Main Street Crystal Lake, Ill. 60014
80294	Bourns, Inc.	1200 Columbia Avenue Riverside, Calif. 92507
80740	Beckman Instruments, Inc.	2500 Harbor Blvd. Fullerton, Calif. 92634
81095	Triad Transformer Corp.	4055 Redwood Avenue Venice, Calif. 90293
81312	Winchester Electronics Div. Litton Ind., Inc.	Main Street and Hillside Ave. Oakville, Conn.
81541	Airpax Electronics, Inc.	Woods Road Cambridge, Md. 21613
82567	Reeves-Hoffman	Cherry - North Streets Carlisle, Pa.
94148	Scientific Electronic Products, Inc.	2303 West 8th Street Loveland, Colo. 80537
95275	Vitramon, Inc.	Box 544 Bridgeport, Conn. 06601
96182	Master Specialties Co.	1640 Monrovia Costa Mesa, Calif. 92627
96791	Amphenol Corp. Amphenol Controls Div.	120 S. Main Street Janesville, Wis. 53545

INDEX

Paragraph  
(Figure)  
\* Table

A

Ac distribution diagram . . . . . (5-16)  
 Adjustment, tuning, and procedures . . . . . 5-2d  
 Alignment final . . . . . 5-2d(8)  
 Amplifier circuit, trouble shooting . . . . . 4-5a(1)  
 Assembly and component location diagrams . . . . . (5-1)  
 Audio Amplifier A5:  
     component location diagram . . . . . (5-8)  
     removal and replacement . . . . . 5-4b(5)  
     schematic diagram . . . . . (5-21)  
     service block diagram . . . . . (4-6)  
     trouble shooting . . . . . 4-8  
     tuning and adjustment . . . . . 5-2d(5)

B

Block diagrams, functional . . . . . (4-2)  
     over-all . . . . . (4-3)  
     service . . . . . (4-4 thru 4-7), 1-10  
     system basic . . . . . (4-1)

C

Cable, external, connections to keyer, location of . . . . . (2-2)  
 Cable interconnection diagram . . . . . (5-23)  
 Cable, primary power, assembly procedure . . . . . (2-3)  
 Characteristics, functional . . . . . 1-3b  
 Circuit, amplifier, trouble shooting . . . . . 4-5a(1)  
 Circuit, signal transition detector, trouble shooting . . . . . 4-5a(2)  
 Circuit test measurements . . . . . \* 3-3  
 Connectors supplied and external cable requirements . . . . . \* 2-1  
 Control settings, preliminary . . . . . \* 5-2  
 Controls and devices, operating . . . . . \* 3-1  
 Controls and indicators, location of . . . . . (3-1)

D

Data quick reference . . . . . 1-3  
 Data cable, assembly procedures . . . . . (2-4)  
 Description, functional . . . . . 1-2  
     over-all functional . . . . . 4-3  
     general . . . . . 4-3a  
 Diagram, cable interconnection . . . . . (5-23)  
 Diagram, component location . . . . . (5-1 thru 5-13)  
 Diagram, disassembly, FS oscillator . . . . . (5-14)  
 Diagram, functional block, keyer . . . . . (4-2)  
 Diagram, over-all block, keyer . . . . . (4-3)

## INDEX (Cont)

Paragraph  
(Figure)  
\* Table

## D (Cont)

Diagram, schematic . . . . .	(5-17 thru 5-22)
Diagram, service block . . . . .	(4-4 thru 4-7)
Diagram, system basic block . . . . .	(4-1)
Dimensions, keyer . . . . .	(2-1)

## E

Emergency maintenance . . . . .	3-5d
Emergency operation . . . . .	3-4
Equipment lists . . . . .	1-4
Equipment, required but not supplied . . . . .	* 1-2
Equipment, special tools and . . . . .	6-5
Equipment, supplied . . . . .	* 1-1
Equipment, test . . . . .	* 5-1

## F

Frequency Calibration, A4:	
component location diagram . . . . .	(5-7)
schematic diagram . . . . .	(5-20)
removal and replacement . . . . .	5-4b(4)
trouble shooting . . . . .	4-7
tuning and adjustment . . . . .	5-2d(3)
voltage check . . . . .	* 5-3
Frequency Shift Oscillator, A3:	
component board diagram . . . . .	(5-4)
disassembly diagram . . . . .	(5-14)
removal and repair . . . . .	5-4b(3)
schematic diagram . . . . .	(5-19)
service block diagram . . . . .	(4-5)
trouble shooting . . . . .	4-6
tuning and adjustment . . . . .	5-2d(7)
Functional block diagram, keyer . . . . .	(4-2)
Functional description . . . . .	1-2
Functional operation . . . . .	3-1

## H

Handling, unpacking and . . . . .	2-1
-----------------------------------	-----

## I

Identification, stock number . . . . .	6-7
Initial operating tests . . . . .	2-5
Installation planning . . . . .	2-3
Installation requirements . . . . .	2-4

## K

Keyer, frequency shift KY-655/FRT . . . . .	(1-1)
Keyer and Transition Relay A2:	
component location diagram . . . . .	(5-3)

INDEX (Cont)

Paragraph  
(Figure)  
\* Table

K (Cont)

removal and replacement . . . . .	5-4b(2)
schematic diagram . . . . .	(5-18)
service block diagram . . . . .	(4-4)
trouble shooting . . . . .	4-5
tuning and adjustment . . . . .	5-2d(3)
voltage check . . . . .	* 5-3

L

Logical trouble shooting . . . . .	4-2
------------------------------------	-----

M

Maintenance illustrations . . . . .	5-5
Maintenance operator's . . . . .	3-5
Maintenance parts list . . . . .	* 6-2, 6-4
Maintenance test equipment . . . . .	* 5-1
Manufacturers, list of . . . . .	* 6-3, 6-6
Modes and outputs, operating . . . . .	* 3-2

O

Operating modes and outputs . . . . .	* 3-2
Operating procedures . . . . .	3-2
Operation, emergency . . . . .	3-4
Operation, functional . . . . .	3-1
Operation, summary of . . . . .	3-3
Operation, summary of . . . . .	* 3-4
Operator's maintenance . . . . .	3-5
Oscillator Board No. 1, (A3A1):	
component location diagram . . . . .	(5-5)
Oscillator Board No. 2, (A3A2):	
component location diagram . . . . .	(5-6)
Outline drawing, keyer . . . . .	(2-1)
Over-all block diagram, keyer . . . . .	(4-3)

P

Power, primary, distribution diagram . . . . .	(5-16)
Power requirements and distribution . . . . .	2-2
Power requirements, primary . . . . .	1-3b(1)
Power Supply PSI:	
component location diagram . . . . .	(5-9)
removal of printed circuit boards . . . . .	(5-15)
removal and replacement . . . . .	5-4b(6)
schematic diagram . . . . .	(5-22)
service block diagram . . . . .	(4-7)
trouble shooting . . . . .	4-9
tuning and adjustment . . . . .	5-2d(2)
Preliminary control settings . . . . .	* 5-2
Procedures, tuning and adjustment . . . . .	5-2d

INDEX (Cont)

	Paragraph (Figure) * Table
Q	
Quick reference data . . . . .	1-3
R	
Rectifier/Filter (PS1A4):	
component location diagram . . . . .	(5-13)
trouble shooting . . . . .	4-9a(3)
Reference data, quick . . . . .	1-3
Reference designations . . . . .	6-2
Regulator, ±10 VDC, (PS1A2):	
component location diagram . . . . .	(5-11)
trouble shooting . . . . .	4-9a(2)
Regulator, ±18 VDC, (PS1A3):	
component location diagram . . . . .	(5-12)
trouble shooting . . . . .	4-9a(2)
Relay Control (PS1A1):	
component location diagram . . . . .	(5-10)
trouble shooting . . . . .	4-9a(1)
Removal and replacement, modules . . . . .	5-4
Repair . . . . .	5-3
Resistance values of A4R6 for various frequency ranges . . . . .	* 5-4
S	
Schematic diagrams . . . . .	(5-17 thru 5-22)
Selection of optional center frequency output . . . . .	5-2e
Selection of optional cw 2000 cps output . . . . .	5-2f
Service block diagrams . . . . .	(4-4 thru 4-7) 4-10
Signal transition detector circuit, trouble shooting . . . . .	4-5a(2)
Special tools and equipment . . . . .	6-5
Stock number identification . . . . .	6-7
Subassembly, rectifier (A4) trouble shooting . . . . .	4-9a(3)
relay (A1) trouble shooting . . . . .	4-9a(1)
T	
Test equipment . . . . .	* 5-1
Tests, initial operating . . . . .	2-5
Tools and equipment, special . . . . .	6-5
Trouble shooting, logical . . . . .	4-2
TTY Selector A1:	
component location diagram . . . . .	(5-2)
removal and replacement . . . . .	5-4b(1)
schematic diagram . . . . .	(5-17)
trouble shooting . . . . .	4-4
tuning and adjustment . . . . .	5-2d(6)
Tuning and adjustment . . . . .	5-2
U	
Units, list of . . . . .	* 6-1, 6-3
Unpacking and handling . . . . .	2-1

# ADDENDUM TO INSTRUCTION MANUAL 6703-0010

for RF-2040 (KY-655), Keyer, Frequency Shift

**Applies to:** All Units

(L39)

## ADDENDUM COVERAGE

This is a three page addendum covering changes to the RF-2040 instruction manual (6703-0010).

## INSTRUCTIONS

Make the following pen-and-ink changes and/or additions to the RF-2040 instruction manual:

1. All references in the manual to the KY-655/FRT are to be changed to or understood as referring to the RF-2040. All references to the MD-777/FRT are to be changed to or understood as referring to the RF-131 Exciter. All references to NAVSHIPS 0967-292-9020/9021 should be deleted.
2. Page 1-2, paragraph 1.3, step a. (4):  
FROM – Contractor: RF Communications, Inc., Rochester, New York, 14610, U.S.A.  
TO – Contractor: RF Communications, Division of Harris Corp., Rochester, New York, 14610, U.S.A.
3. Page 1-4, Table 1-1, mark entire table: "See Table 1-1 in Addendum L39 at the front of this manual."
4. Page 2-5, figure 2-2, reference designator at "AC Power Cable" should be "A7FL1J1".
5. Page 2-5, Table 2-1, add: "Keyer/exciter cable-refer to 0426-9000-connector MS3116E12-10SX".
6. Page 3-1, delete the first paragraph under "3-1. Functional Operation", and replace it with the following:  
"Keyer/Frequency Shift RF-2040 is intended for operation with the RF-131 Exciter as used in an RF-130 (1 kW) or RF-745 (10 kW) Transmitting System.
7. Page 3-1, last paragraph under "3-1. Functional Operation", add: "Note that there is no remote control unit used with the RF-2040".
8. Page 3-6, Table 3-4, column 4 (Starting), change "put the transmitter to an "in the air" condition" to "put the transmitter to an "on the air" condition".
9. Page 4-5, paragraph 4-4 "TTY Selector (A1)", step a. (Description), change "TTY INPUT SELECTOR switch and per CW key input," to "TTY INPUT SELECTOR switch and for CW key input,".
10. Page 4-6, second paragraph, change "firing voltage, Q7 conducts" to "firing voltage, Q9 conducts", "The contacts (5 and 8)" to "The contacts (4 and 6)", and "K1 contacts 7 and 9" to "K1 contacts 3 and 5".
11. Page 4-7, first paragraph, last line, change "L13 filters" to "L14 filters".
12. Page 4-7, second paragraph, change "Mode switch S1-G" to "Mode switch S1-F".
13. Page 4-8, second paragraph under "4-8. Audio Amplifier (A5)", change "FUNCTION TEST switch A6S2G." to "FUNCTION TEST switch A6S2C.".



# ADDENDUM TO INSTRUCTION MANUAL 6703-0010

14. Page 4-9, second paragraph, last line, change ". . . open circuits through B2 and B3," to ". . . open circuits through K1 contacts B2 and B3,".
15. Page 5-1, Table 5-1, change "AN/PSM-6" to "Simpson 260 or equivalent", and "AN/USM-207" to "Hewlett Packard 5245L or equivalent".
16. Page 5-6, step (6) "TTY Selector (A1)", change "(see figure 5-6)" to "(see figure 5-2)".
17. Page 5-10, step 11.b., last line, change "A2R8" to "A2R14", step 10, change "A7J1FL2" to "A7FL2J1".
18. Page 5-11, step 11.c., top of the page, change "A2R8" to "A2R14" (two places).
19. Page 5-11, step 11.d., top of the page, Change "A7J1FL2" to "A7FL2J1".
20. Page 5-22, Figure 5-5, change reference designator callouts from "Q6" (top right) to "Q5", and "Q5" (bottom center) to "Q6".
21. Page 5-33/5-34, Figure 5-18, bottom left-hand side of schematic, change "R15 270" to "R15 27".
22. Page 5-47/5-48, Figure 5-23, make the following changes:
  - (a) From - "J1FL2", To - "FL2J1"
  - (b) From - "J1FL1", To - "FL1J1"
  - (c) From - "A7FL2", To - "A7FL2J1"
  - (d) Label pins E and F (FAULT MONITOR), on the left-hand side of the schematic, "P/O A7J1".
  - (e) At note 3, delete "NAVSHIPS 0967-292-9020".
23. Page 6-1, first paragraph, third line, change "National Radio Company, Inc., Melrose, Mass." to "RF Communications, Division of Harris Corp., Rochester, N.Y.".
24. Page 6-3, Table 6-1, reference designator A2, change from "Keyer and Transistor Relay" to "Keyer and Transition Relay".
25. Change all manufacturer codes from "14303" and/or "42498" to "14304".
26. Page 6-6, reference designator R15, change part no. from "RC07GF271K" to "RC07GF270K".
27. Page 6-6, reference designator R18, change from "Same as R15" to "Resistor: Mil type RC07GF271K", and change all further "Same as R15" to read "Resistor: Mil type RC07GF271K".
28. Page 6-6, reference designator R41, delete "Not Shown" and add "See Figure 5-3".
29. Page 6-9, reference designator R3, change part no. from "RC07GF272J" to "RC07GF272K".
30. Page 6-13, reference designators F1, F2, and K1, change dashes in part numbers to slashes (/). The part nos. should read; F1: F02A250V1/8A, F2: FM03-1/8A, K1: M5757/9-003.
31. Page 6-14, reference designators MP8 and MP9, change part no. from "A44599-6" to "D44599-6".
32. Page 6-23/6-24, MFR code 14304, change from "RF Communications, Inc." to "RF Communications, Division of Harris Corp.".



# ADDENDUM TO INSTRUCTION MANUAL 6703-0010

TABLE 1-1. EQUIPMENT SUPPLIED

QTY. PER EQUIP.	NOMENCLATURE		DIMENSIONS (INCHES)		
	NAME	PART NO.	H	W	D
1 ea.	Keyer Frequency Shift	RF-2040	3.5 (Vol. 0.85 cu. ft.)	19 (Wt. 40 lbs)	22.5
2 ea.	Instruction Manual	6703-0010	10.75	8.25	0.50
1 set	RF-2040 Interface Instructions	0426-9000	---	---	---
1 ea.	Connector w/AC line cord	MS3108R-14S-7S	---	---	---
1 ea.	Connector w/CE Jumper	MS3116E-12-10SX	---	---	---
1 ea.	Connector w/M-N Jumper	MS3116F-14-15SW	---	---	---
1 ea.	Extender Cable	C45629G1	---	---	---
1 ea.	Extender Cable	C45630G1	---	---	---
8 ea.	Screw	MS51958-64	---	---	---
8 ea.	Lock Washer	MS35338-138	---	---	---
8 ea.	Flat Washer	MS15795-808	---	---	---

