

SECTION 4 - ANTENNA COUPLERS

4.1 AN/SRA-13, 14, & 15 GENERAL DESCRIPTION

a. The AN/SRA-13, 13A, and 13B antenna coupler group is capable of coupling four transmitters with output power up to 500 watts each into a single broadband antenna. Each transmitter operating with a coupler group must be set to operate at channels spaced at least 10 percent from any other frequency in the group. Each coupler operates over a frequency range of 2 to 6 megacycles. The AN/SRA-13A group is electrically and mechanically interchangeable with antenna coupler group AN/SRA-13; internal components parts differ. The AN/SRA-13B is electrically and physically interchangeable with AN/SRA-13 and AN/SRA-13A except that the components comprising the redesigned area of the AN/SRA-13B are not interchangeable with corresponding components of the AN/SRA-13 and AN/SRA-13A.

b. The AN/SRA-14, 14A, and 14B antenna coupler group is capable of coupling four transmitters with output power up to 500 watts ^{EACH} into a single broadband antenna. Each transmitter operating with a coupler group must be set to operate at channels spaced at least 10 percent from any other frequency in the group. Each coupler operates over a frequency range of 4 to 12 megacycles. The AN/SRA-14A group is electrically and mechanically interchangeable with antenna coupler group AN/SRA-14; internal components parts differ. The AN/SRA-14B is electrically and physically interchangeable with AN/SRA-14 and AN/SRA-14A except that for component parts compressing the redesigned area. The AN/SRA-14B has been redesigned so that meters and toggle switches provide incident power information as well as reflected power data.

c. The AN/SRA-15, 15A, and 15B antenna coupler group is capable of coupling four transmitters with output power up to 500 watts each into a single broadband antenna. Each transmitter operating with a coupler group must be set to operate at channels spaces at least 10 percent from any other frequency in the group. Each coupler operates over a frequency range of 6 to 18 megacycles. The AN/SRA-15A group is electrically and mechanically interchangeable with antenna coupler group AN/SRA-15; internal components parts differ. The AN/SRA-15B is electrically and physically interchangeable with AN/SRA-15 and AN/SRA-15A except that for component parts compressing the redesigned area. The AN/SRA-15B has been redesigned so that meters and toggle switches provide incident power information as well as reflected power data.

4.2 REFERENCE DATA

- a. Table of Technical Publications - Table 4-1
- b. Primary Power Requirements - Table 4-2
- c. Heat Dissipation - Table 4-3
- d. Unit Weight - Table 4-3

4.3 INSTALLATION REQUIREMENTS

a. Arrangement - The AN/SRA-13, 14, and 15 are designed for mounting in an upright position on the deck. See Figure 4-1 for typical foundation details. Make certain that the cabinet is level to ensure smooth working control shafts. Clearance of 24 inches is required at front of multicoupler for removal of drawer assemblies, 15 inches is required at right side for connection of matching network, and 3 inches is required at left side for ventilation.

b. Outline and Mounting Dimensions - Figure 4-2.

c. Grounding Specifications - All bonding and grounding to be in accordance with Table 4-1, Item No. 2.

4.4 CABLE DIAGRAM AND CONNECTION DETAILS

a. Elementary Connections - Figure 4-3.

b. Electronics Installation and Maintenance Standards - To be in accordance with Table 4-1, Item No. 7.

c. Security Requirements - To be in accordance with Table 4-1, Item No. 9

4.5 FIELD CHANGE REQUIREMENTS - See Table 4-1 Item No. 7.

ORIGINAL

| ITEM NO. | NAVSHIPS NO. DRAWING NO. MIL. STD. NO. | TITLE |
|----------|----------------------------------------------|-----------------------------------------------------------------------------------------------------------------------------------|
| 1 | 0280-381-6006` | Technical Manual for Antenna Coupler Groups AN/SRA-13, 13A, 13B, 13C, AN/SRA-14, 14A, 14B, 14C, and AN/SRA-15, 15A, 15B, and 15C. |
| 2 | Mil. Std. 1310A (NAVY) | Shipboard Bonding and Grounding Methods for Electromagnetic Compatibility |
| 3 | 0967-177-3030 | Shipboard Antenna Systems Volume 3 Multicoupler Systems |
| 4 | *RE-F2687921 | Outline and Mounting Data |
| 5 | *RE-F2687922 | Pictorial System Diagram |
| 6 | *RE-C2687931 | Primary Power Distribution Diagram |
| 7 | 0967-000-0000 | Electronics Installation and Maintenance Books |
| 8 | 0981-052-8090 | Data Pertaining to Electrical Shipboard Cable |
| 9 | NAVSHIPS INST. 05510.33B | Installation Criteria for Shipboard Secure Electrical Information Processing System |
| | | |
| | | |

*These plans are not essential for installation, but if available use as reference.

TABLE OF TECHNICAL PUBLICATIONS

TABLE 4-1

ANTENNA COUPLERS

NAVSHIPS 0967-306-1010

TABLE 4-1

| EQUIPMENT | VOLTAGE | CURRENT | POWER | REMARKS |
|-------------------------------------|---------------------------------|---------|--------------|----------------------------|
| AN/SRA-13 AN/SRA-14 AN/SRA-15 | 115 VAC, 60 HZ, Single Phase | | 345 watts | Power - Maximum on Standby |

TABLE OF PRIMARY POWER REQUIREMENTS
TABLE 4-2

| EQUIPMENT | HEAT DISSIPATION | UNIT WEIGHT |
|-----------|---------------------|----------------|
| AN/SRA-13 | 310 WATTS | 306 LBS. |
| AN/SRA-14 | 310 WATTS | 230 LBS. |
| AN/SRA-15 | 310 WATTS | 276 LBS. |
| | | |

TABLE OF MISCELLANEOUS DATA
TABLE 4-3

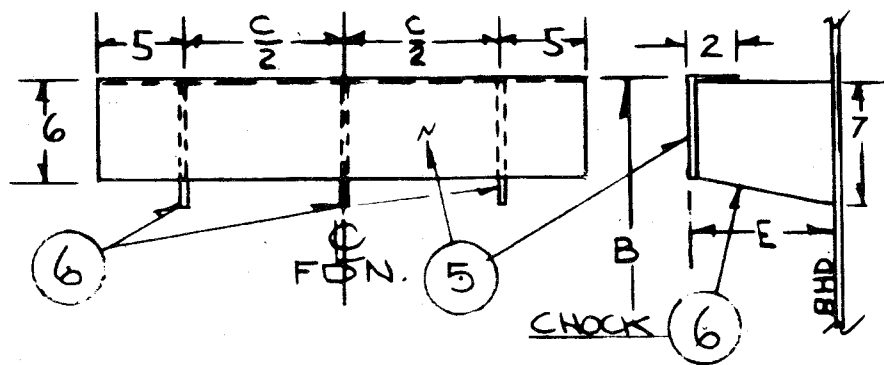

DETAIL "A"

ONLY FOR BHD. MOUNT.
USE IN LIEU OF PCS. # 2 & # 3
WITH PCS. # 1 & # 4

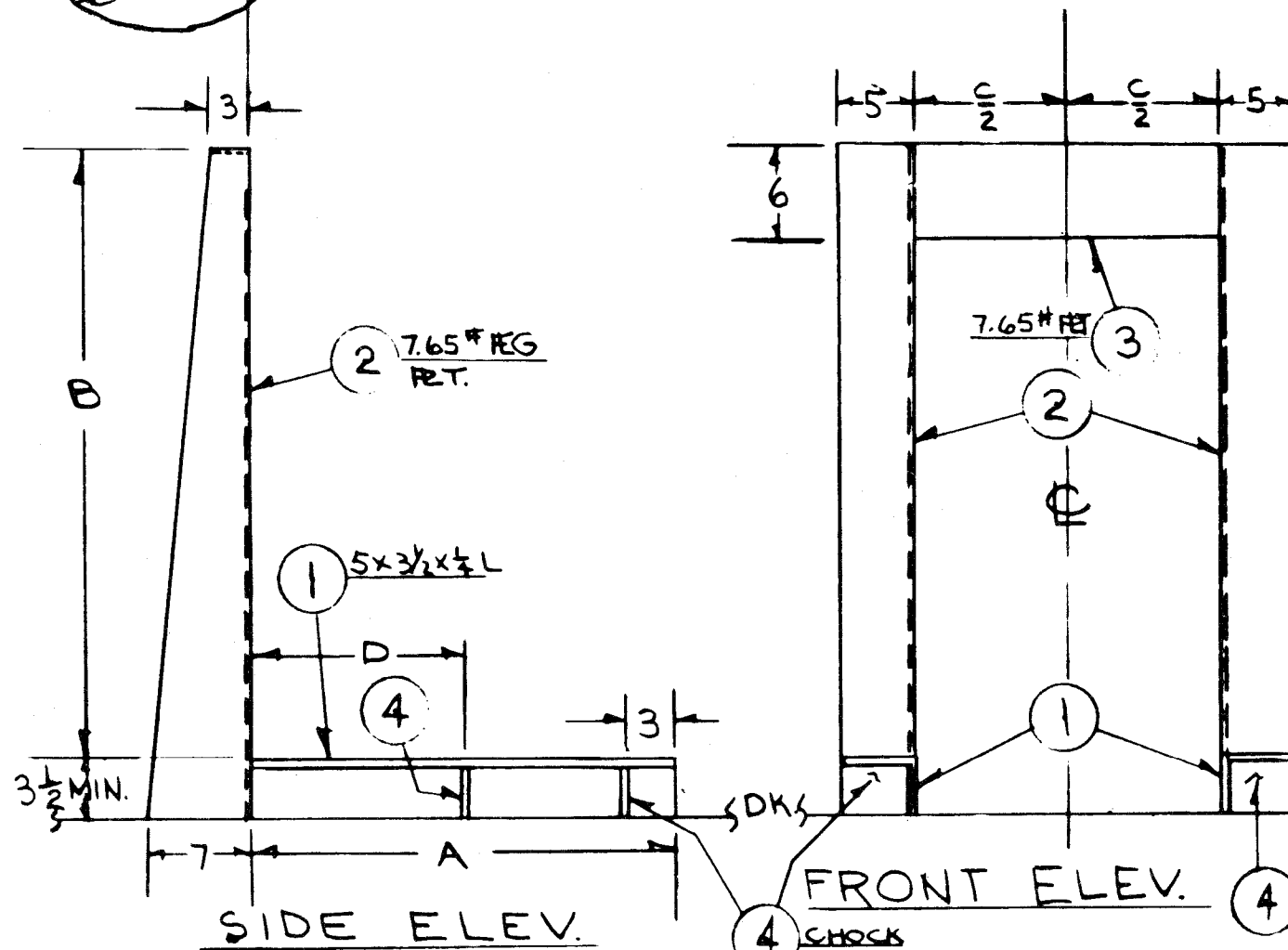
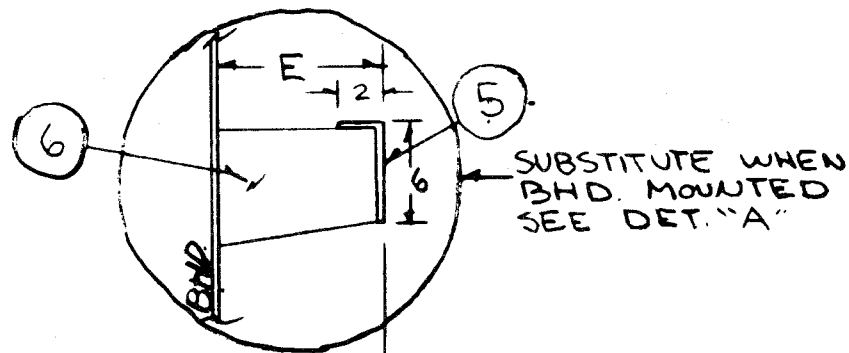

ANTENNA COUPLERS

FIGURE 4-1

| LIST OF MATERIAL-QUANTITIES FOR ONE SHIP | | | | | |
|------------------------------------------|---------------------|-----------|----------|-------------|----------------|
| Piece No. | NAME | No. Req'D | MATERIAL | Mt'l Spec. | Remarks |
| 1 | 5X3 1/2 X 1/4 Angle | 2 | M. Stl. | Mil-S-20166 | |
| 2 | 7.65# Plt. | 2 | M. Stl. | Mil-S-16113 | |
| 3 | 7.65# Plt. | 1 | M. Stl. | Mil-S-16113 | |
| 4 | 7.65# Plt. | 4 | M. Stl. | Mil-S-16113 | |
| 5 | 7.65# Plt. | 1 | M. Stl. | Mil-S-16113 | Bhd. Mtg. Only |
| 6 | 7.65# Plt. | 3 | M. Stl. | Mil-S-16113 | Bhd. Mtg. Only |
| | | | | | |
| | | | | | |

NOTES:

1. All variable dimensions and type of foundation to be specified on location.
2. Foundation for AN/SRA-16 to be as follows:
 - a. Dimension "A" = 26"
 - b. Dimension "B" = 39 1/2"
 - c. Dimension "C" = 17 1/2"
 - d. Dimension "D" = 13 1/4"
 - e. Dimension "E" = A/R
3. Foundation for AN/SRA-13, 14, and 15 to be as follows:
 - a. Dimension "A" = 20"
 - b. Dimension "B" = 46 1/2"
 - c. Dimension "C" = 14 1/2"
 - d. Dimension "D" = 10"
 - e. Dimension "E" = A/R
4. Size and location of mounting bolts for unit to be taken from equipment.

AN/SRA-13, 14, 15, & 16
ANTENNA COUPLER GROUP
TYPICAL FOUNDATION DETAILS
FIGURE 4-1

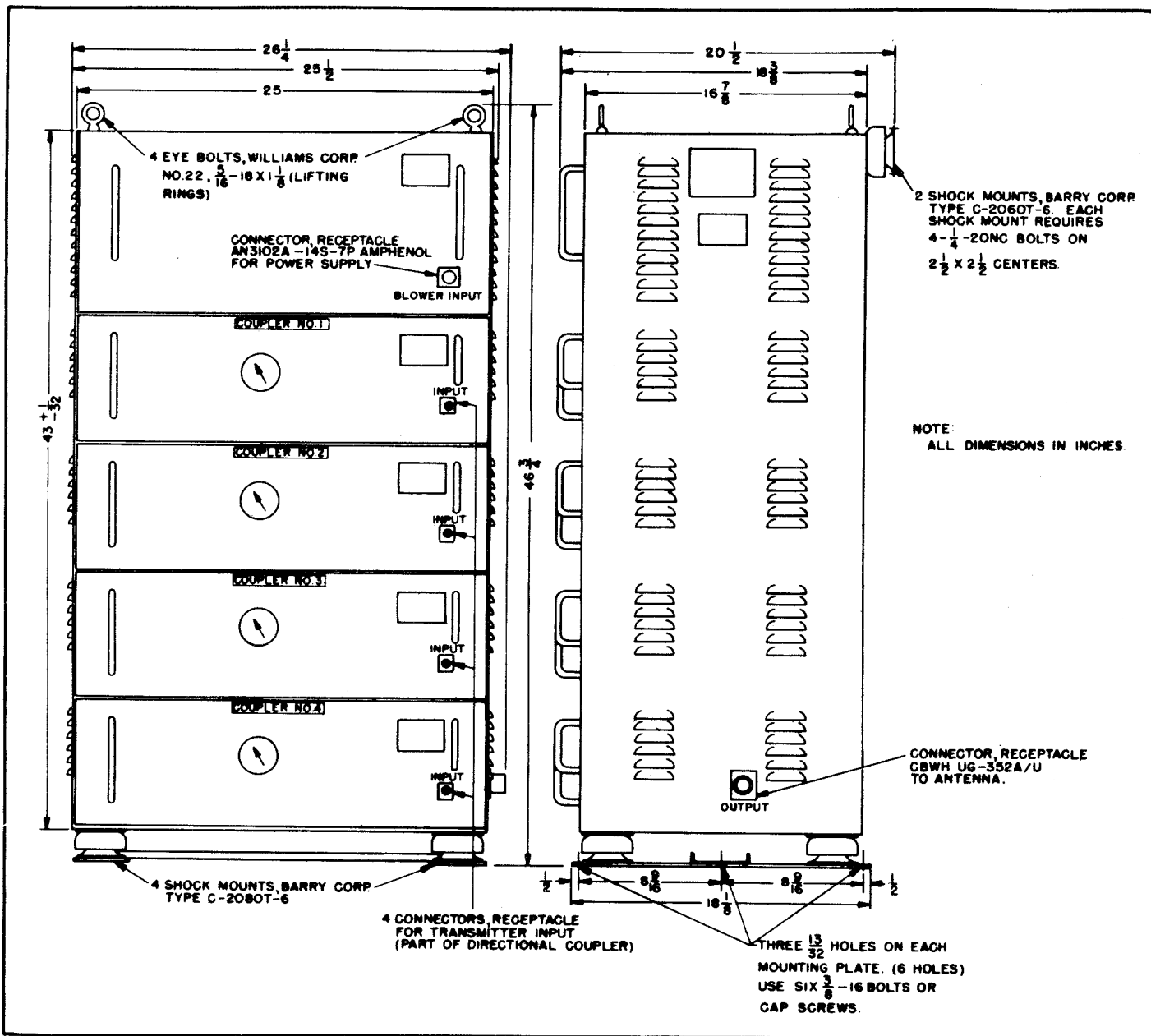

AN/SRA-13, 14, AND 15
OUTLINE AND MOUNTING DIMENSIONS
FIGURE 4-2

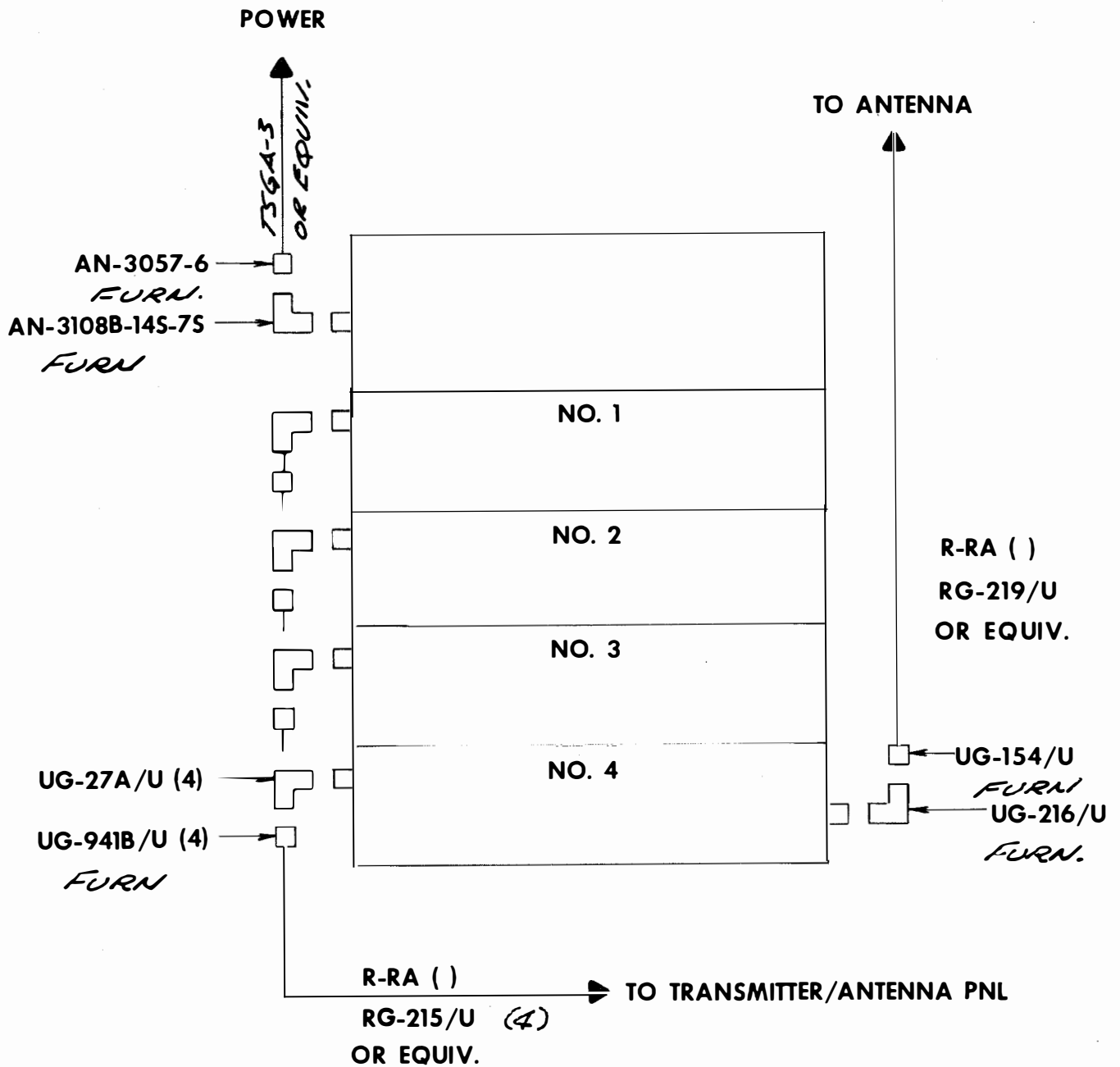

AN/SRA-13, 14, AND 15 ANTENNA COUPLERS CABLE DIAGRAM

FIGURE 4-3

SECTION 4 - ANTENNA COUPLERS

4.6 AN/SRA-16 GENERAL DESCRIPTION

The AN/SRA-16, 16A, 16B antenna coupler group is capable of coupling four transmitters into a single broadband antenna. The principal function of this equipment is to provide an efficient means for operating several transmitters having an output power up to 500 watts into a single broadband antenna. Each transmitter operating with a coupler group must be set to operate at channels spaced at least 10 percent from any other frequency in the group. Each coupler operates over a frequency range of from 9 - 26 megacycles, in three steps, under control of a band switch which selects either the 9 - 12 megacycles range, the 12 - 18 megacycles range or the 18 - 26 megacycles range. The AN/SRA-16A group is electrically and mechanically interchangeable with antenna coupler group AN/SRA-16; internal components parts differ. The AN/SRA-16B group is electrically and physically interchangeable with AN/SRA-16 and AN/SRA-16A except for component parts of redesigned area. The AN/SRA-16B has been redesigned so that meters and toggle switches provide incident power information as well as reflected power data.

4.7 REFERENCE DATA

- a. Table of Technical Publications - Table 4-4
- b. Primary Power Requirements - Table 4-5
- c. Heat Dissipation - Table 4-6
- d. Unit Weight - Table 4-6

4.8 INSTALLATION REQUIREMENTS

a. Arrangement - The AN/SRA-16 is designed for mounting in an upright position on the deck. See Figure 4-1 for typical foundation details. Make certain that the cabinet is in a level position to insure smooth working control shafts. Clearance of 30 inches is required at front of multicoupler for removal of drawer assemblies, 15 inches is required at right side for connection of transmission line and 3 inches is required at left side for ventilation.

- b. Outline and Mounting Dimensions - Figure 4-4.
- c. Grounding Specifications - All bonding and grounding to be in accordance with Table 4-4, Item No. 2.

4.9 CABLE DIAGRAM AND CONNECTION DETAILS

- a. Elementary Connections - Figure 4-5.
- b. Electronics Installation and Maintenance Standards - To be in accordance with Table 4-4, Item No. 5.
- c. Security Requirements - To be in accordance with Table 4-4, Item No. 7.

4.10 FIELD CHANGE REQUIREMENTS - See Table 4-4 Item No. 5.



ORIGINAL

| ITEM NO. | NAVSHIPS NO. DRAWING NO. MIL. STD. NO. | TITLE |
|----------|----------------------------------------------|-------------------------------------------------------------------------------------|
| 1 | 0280-401-6003 | Technical Manual for Antenna Coupler Groups AN/SRA-16 and AN/SRA-16A |
| 2 | Mil. Std. 1310 (NAVY) | Shipboard Bonding and Grounding Methods for Electromagnetic Compatibility |
| 3 | *RE-F2687920 | Pictorial System Diagram |
| 4 | *RE-F2697919 | Outline and Mounting Data |
| 5 | 0967-000-0000 | Electronics Installation and Maintenance Books |
| 6 | 0981-052-8090 | Data Pertaining to Electrical Shipboard Cable |
| 7 | NAVSHIPS INST. 05510.33B | Installation Criteria for Shipboard Secure Electrical Information Processing System |
| | | |
| | | |

*These plans are not essential for installation, but if available, use as reference.

TABLE OF TECHNICAL PUBLICATIONS

TABLE 4-4

ANTENNA COUPLERS

NAVSHIPS 0967-306-1010

TABLE 4-4

ANTENNA COUPLERS

| EQUIPMENT | VOLTAGE | CURRENT | POWER | REMARKS |
|--------------------------|------------------------------|---------|-----------|--------------------------|
| AN/SRA-16 and AN/SRA-16A | 115 VAC, 60 Hz, Single Phase | | 345 Watts | Maximum power on standby |

TABLE OF PRIMARY POWER REQUIREMENTS
TABLE 4-5

NAVSHIPS 0967-306-1010

| EQUIPMENT | HEAT DISSIPATION | UNIT WEIGHT | REMARKS |
|--------------------------|------------------|-------------|---------|
| AN/SRA-16 and AN/SRA-16A | 310 Watts | 320 Lbs. | |

TABLE OF MISCELLANEOUS DATA
TABLE 4-6

TABLE 4-5/4-6

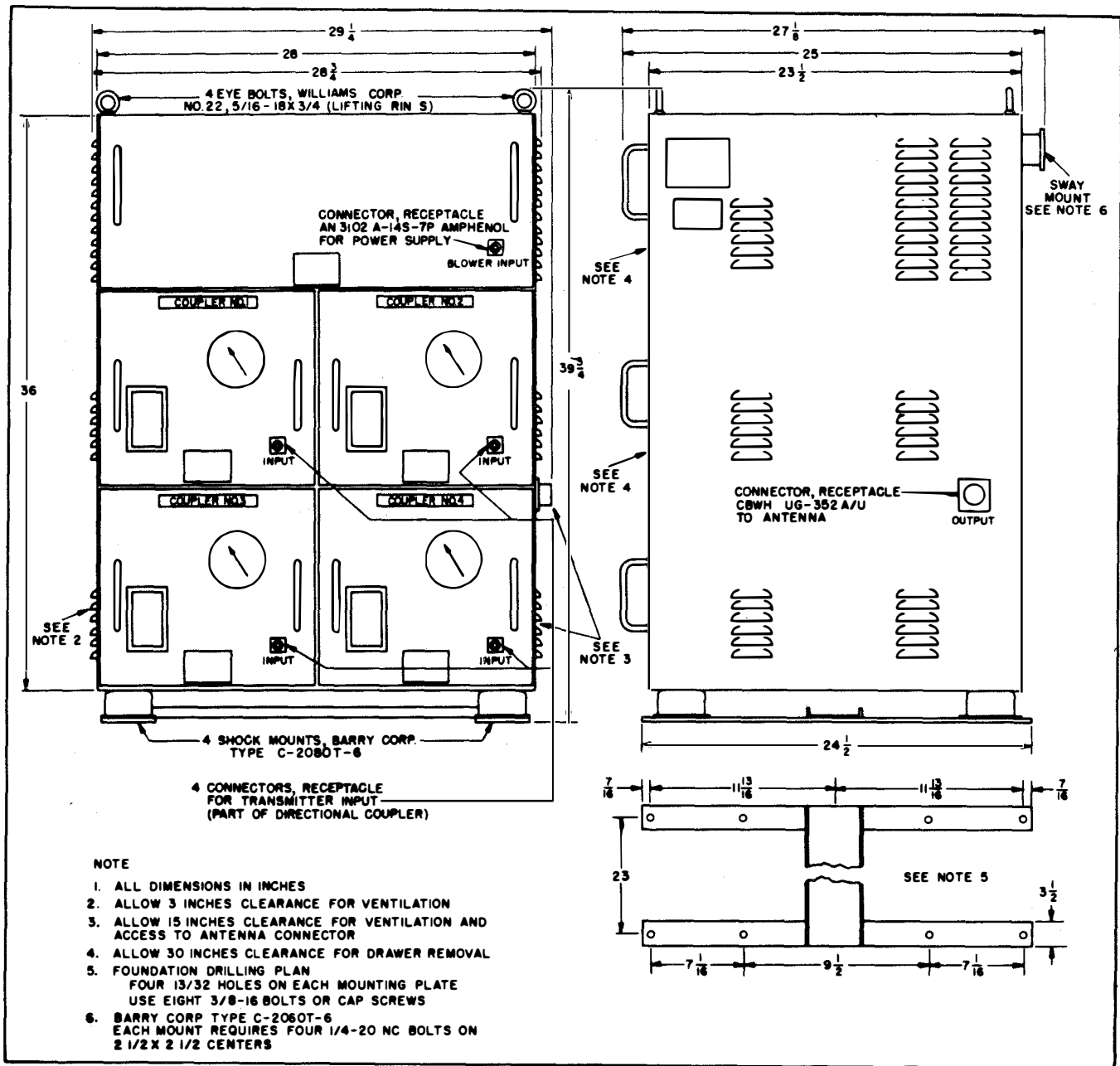

AN/SRA-16 OUTLINE AND MOUNTING DIMENSIONS

FIGURE 4-4

FIGURE 4-5

NAVSHIPS 0967- 306- 1010

ANTENNA COUPLERS

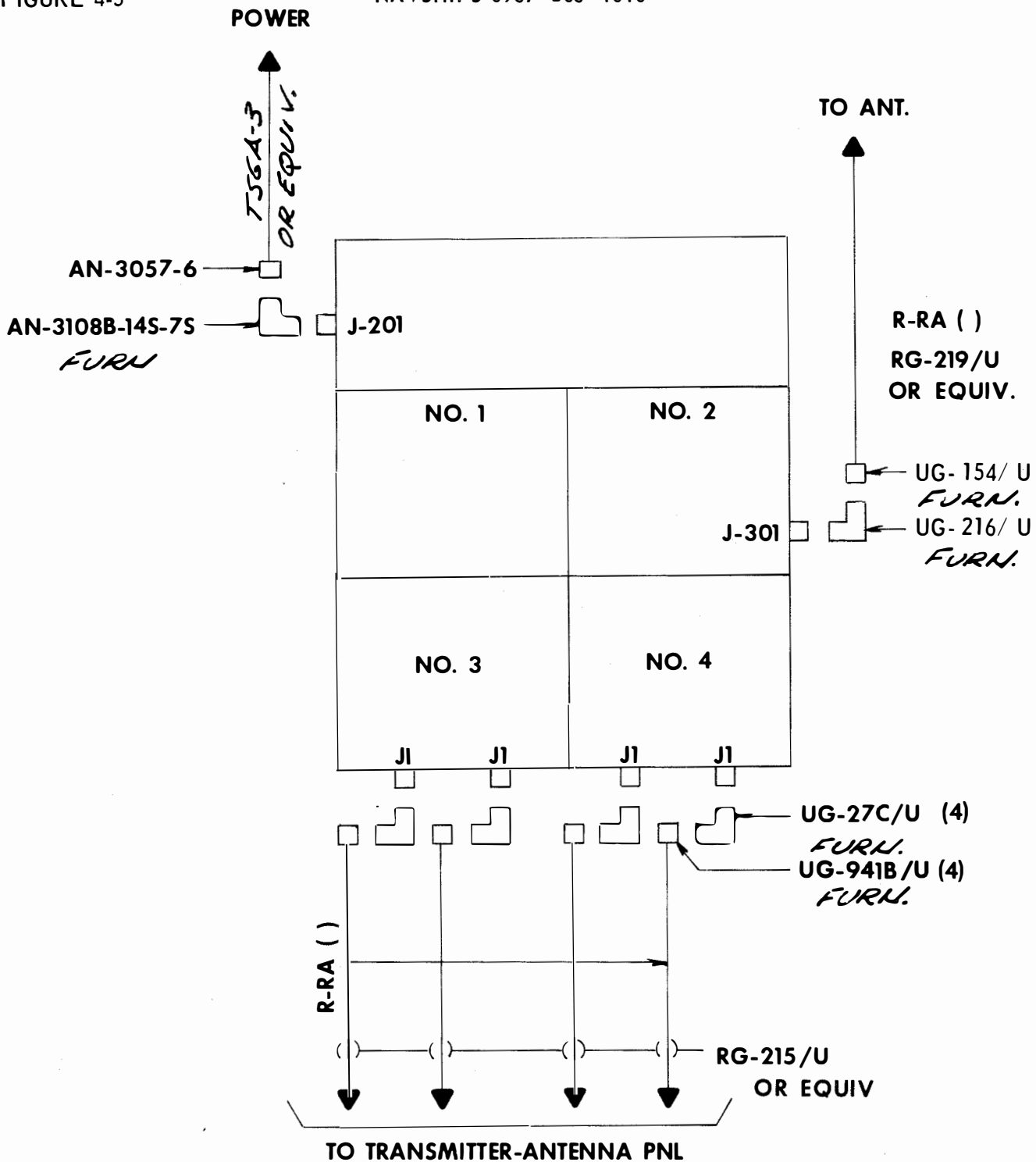

AN/SRA-16 ANTENNA COUPLER
CABLE DIAGRAM

FIGURE 4-5