

HOLLOW STATE NEWSLETTER

"For lovers of vacuum tube radios"

Issue # 44
Spring 1998

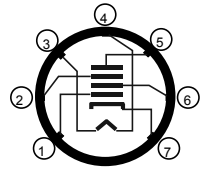

HSN is produced and published by and for the community of those who appreciate the fine accomplishments of the manufacturers of 'top of the line' vacuum tube communication radios and auxiliary equipment. Originally created by a group of R-390 users, HSN has expanded to include industrial, military, and consumer grade receivers by Collins, Hammarlund, National, Hallicrafters and others. HSN includes tips, modifications, alignment and restoration advice, product reviews, parts, tubes and service sources, and subscriber buy/sell information - all provided by subscribers and friends of HSN. See page 8 for submissions, disclaimers, reprinting, copyrights, subscriptions, reprints, and the Editor's and Publisher's Corner.

Editor – Reid Wheeler
5910 Boulevard Lp SE
Olympia WA 98501-8408
Phone: (360) 786-6756 6-9pm PLT
Fax: (360) 753-3824 anytime
E-mail: reid@olywa.net

Publisher – Ralph Sanserino
P.O. Box 1831
Perris CA 92572-1831
E-mail: sanser@pe.net

CONTENTS

	Page
Feature Articles	
Heath Vacuum Tube Voltmeters – Kurt H. Miska	1
Departments	
Questions and Answers from Our Readers	6
Short Subjects – <i>Litz Wire-the effects of broken strands</i>	6
<i>Additional Manual Sources</i>	7
Publications of Interest	7
Buy/Sell/Trade Items	7,8

THE HEATH VACUUM TUBE VOLTMETERS - THE UNIVERSAL TEST INSTRUMENT AND A PIECE OF ELECTRONIC HISTORY

by Kurt H. Miska, N8WGW, khm@tir.com
3488 Wagner Woods Court, Ann Arbor, MI 48103

This article originally appeared in Electric Radio magazine, under the title "The Heath Vacuum Tube Voltmeters," October 1994, No. 66, p. 28. This revised version is reproduced here with the permission of the publisher and editor of Electric Radio magazine.

Once the mainstay of nearly every electronics workbench in the country, and possibly the world, the ubiquitous and classic vacuum tube voltmeter, always known simply as a VTVM, has for all practical purposes disappeared. Its demise can probably be attributed almost entirely to the appearance of the digital multimeter and a few FET analog voltmeters. VTVMs, once made by nearly all manufacturers of test equipment, came in a wide range of shapes, sizes and prices. Many of them were also available as kits.

For this article, it is best to classify VTVMs in two categories. The first would be the relatively simple Heath, Eico, RCA and Knight (Allied Radio) instruments, and the second category would include the much more sophisticated VTVMs produced by Hewlett Packard, Ballantine, Boonton, and similar companies. This effectively separates these instruments by price. The meters in the first category were priced within the reach of virtually all amateurs and experimenters and were generally priced below \$50. On the other hand, the much more complex meters in the second category were well into the three-figure range. This article deals with the classic Heathkit VTVMs.

WHY A VACUUM TUBE VOLTMETER?

The vacuum tube voltmeter is as old as the thermionic diode, or, to put it more simply, 102 years old, according to the introduction in John F. Rider's book Vacuum Tube Voltmeters. With the rapid maturing of the electronics industry in the 1930s, engineers and designers developed increasingly sophisticated VTVM

circuits, using triodes and pentodes, that minimized loading of high impedance circuits. It is a well-known fact that even 20,000 ohms/volt meters load circuits excessively, to the point where readings are, for all practical purposes, meaningless. The VTVM, with at least several megohms of input impedance, solves the problem.

Fundamentally, there are two types of VTVMs - diode types and triode types. I'll bypass the former since they are no practical commercial instruments of this type. High input impedance amplifiers were available in the 1930s and it stood to reason that coupling such an amplifier to a meter would produce an instrument that could measure DC voltages. From there it was but a small step to adding a voltage divider to the amplifier input so as not to damage the measuring circuit with high voltages. That was the beginning.

The Heath VTVMs, and also those offered by Eico, RCA, Hickock and Knight, basically comprised three circuits--a power supply, the metering circuit, and rectifier circuit to handle alternating current. Generally, the power supply was a very modest affair consisting, in the early days, a selenium rectifier and, in later, more compact models, a silicon diode. The metering circuit was designed around a twin triode--a 6SN7 in the earlier instruments and the more compact 12AU7 in later models. Similarly, AC was first handled by a 6H6 and later by a miniature 6AL5.

For an understanding of the theory of operation of these VTVMs, permit me to quote from Basic Electronic Test Instruments, an old, easy-to-understand text I picked up for a dollar at hamfest.

"A difficulty often experienced with simple triode voltmeters is the tendency of meter zero to shift from original balance. This occurs slowly during periods of operation on a single voltage range, and abruptly when changing from one range to another. Frequent readjustment of the zero set rheostat is necessary. The simple triode circuit is subject also to power supply fluctuations and to variations in tube characteristics. These conditions are relieved in the circuit shown in the accompanying schematic. While basically a DC VTVM, this circuit may be used also to check AC voltages, as will be shown later, by preceding it with a diode rectifier. A single twin-triode, such as the ubiquitous 12AT7, is used. V1 handles the applied test voltage, while V2 is a balancing tube.

"A high resistance, R3, is connected in series with the junction point of the two cathode resistors (R1 and R2) and the source of bias voltage. Because of its high value, this resistance, rather than the tube characteristics, largely determines the cathode current. The circuit accordingly is divorced almost completely from variations in tube

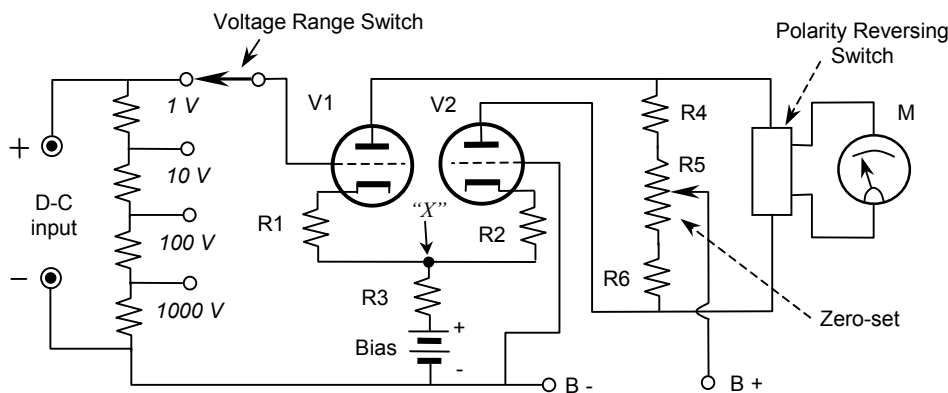

characteristics and from small plate-current changes resulting from tube and power-supply fluctuations. When a positive test voltage is applied to the upper input terminal, tube V1 draws increased plate current, raising point "X" to a higher positive value. This increased positive potential is applied automatically to the cathode of V2, thereby reducing the plate current of that tube. The net result of this action is to make the top of R4 more positive and the bottom of R6 less positive. This difference of potential causes a current to

flow through the meter, M. If the upper input terminal inadvertently is made negative, the meter would be directed downward. However: the polarity-reversing switch may be thrown to obtain an upward deflection for the negative input voltage. This feature removes the necessity of interchanging the test leads. To measure AC voltages a simple rectifier circuit is added to the front end of the twin-triode circuit.

"The input resistance of triode VTVMs is the total resistance of the input voltage divider associated with the range switch. This resistance is as high as 100 megohms in some commercial instruments, but values between 10 and 20 megohms are more common."

The Heath VTVMs used so widely by radio and TV service shops, and by radio amateurs and experimenters measured DC, AC and resistance. Most of them measured up to 1,000 volts AC and DC and resistance up to 1,000 megohms. On many of them the DC range could be extended to a staggering 30,000 volts by means of a well-insulated probe. Some could measure RF voltages with a demodulator probe.

THE QUINTESSENTIAL VTVM

Sometimes the words VTVM and Heathkit seem almost synonymous. Talk to most hams, electronic experimenters, or TV service technicians and they will either fondly recall their first Heathkit VTVM or they will say that they cherish the one still doing yeoman's service on their workbench.

The Heath Company in Benton Harbor, Michigan introduced its first VTVM, the model V-1, in November 1947, shortly after the company started offering its O-1 oscilloscope kits. The model V-1, in kit form, sold for the princely sum of \$24.50. It is not known how long the V-1 remained in production.

According to Heath historian Chuck Penson, WA7ZZE, in St. Paul, Minnesota, the basic Heath design philosophy was to reverse engineer and simplify the considerably complex circuits found in expensive industrial instruments, such as those made by Hewlett Packard and others. Thus, the design embodied in the V-1 became the foundation for all of its VTVMs up to the model V-7A. That first unit used a 6X5 rectifier, a 6SN7 meter amplifier, and a 6H6 half-wave doubler to deal with measuring AC. Its ranges were 0-3, 0-30, 0-100, and 0-1000 volts AC and DC on a linear scale and up to 1,000 megohms of resistance, a feature largely unmatched by the manufacturers of today's digital multimeters. It also featured a dB scale. The meter movement was a 500-microampere unit in a clear plastic housing and the range switches were hefty ceramic units. The clear meter housing became very much a trademark of all Heath VTVMs.

An advertisement described the V-1 in glowing, but probably justified, terms. "The best quality of materials is supplied -- aluminum cabinet, beautiful two color panel, 500 microamp meter, ceramic switches, glass enclosed precision voltage divider resistors, and every required part right down to the hook-up wire. Detailed blueprints and instructions make the assembly pleasant and simple. Average construction time is less than four short hours, and you have the best and most useful test instrument available."

Heath's reputation as a maker of quality kits was further enhanced by its excellent construction/instruction manuals. With careful workmanship, and systematically checking off each step, the builder couldn't help but build an instrument that worked when turned on for the first time.

Another line in that same ad reads, and again probably merited, "acclaimed by all who have seen it the most beautiful radio test instrument on the market."

Little is known about the V-2 and V-3 instruments. In all probability they were very similar to the V-1. We do know though that the V-4 was first produced in 1950. Each subsequent model offered small

improvements and by the time the model V7A was offered, Heath had sold half a million VTVMs. The V-7A, the last of the V-series, was also the first of Heath's VTVMs to use a printed circuit board. The V-7A's voltage ranges are in sequences of 1.5, 5 for RMS and a 4, 14 for peak-to-peak measurements. (1.5 V RMS x 2.828 = 4.2 V peak-to-peak.)

The multi-function VTVMs (DC, AC, ohms) included the series from the V-1 through the V-7A, the IM-11, IM-18 and the IM-5218. The IM-5218 marked the end of the line for the company's VTVMs, that model lasting to 1983.

There were three VTVMs with horizontal panel layouts designed to be placed on the workbench or suspended below a shelf over the workbench. They included the IM-13, IM-28 and the IM-5228 available from March 1963 to 1968. Like the other Heath VTVMs, they featured seven AC, seven DC, and seven resistance ranges.

Then there were the Deluxe Service Bench VTVMs with the 6 in. meter movements, multi-colored meter scales, and separate low voltage AC scales. Two models were built between 1960 and 1963; the IM-10 from 1960 to 1962 and the IM-32 from July 1962 to 1963.

The IM-11 VTVM represented a departure from the classic V-series. The most obvious change was use of a single switchable AC/DC/ohms test probe with a short ground lead. DC for one setting and AC and ohms for the other. I briefly owned an IM-11 but the single probe for everything was, to my way of thinking, uncomfortable and I traded it for a mint V-6A.

The following is quoted directly from the Heath instruction manual for the Model V-7A, but applies pretty much equally to all the Heath VTVMs from the V-1 to the V-7A. Obviously, the earlier VTVMs used different tubes, but, in principle, the description applies.

"The sensitive 200 microampere meter movement is in the cathode circuit of a 12AU7 twin-triode. The zero adjust control balances the two sections of the triode such that with zero input voltage applied to the first grid, the voltage drop across each portion of the zero adjust control is the same. This being true, the meter reads zero. Applying a voltage to the first grid, upsets the balance in the cathode circuit and the meter provides an indication. The relationship between the test voltage applied to the first grid and the meter indicating current is linear and therefore the meter is calibrated with a linear scale. The advantage of having the meter in a vacuum tube circuit of this kind is that the voltage to be measured is not applied directly to the meter but rather to the tube. Because the tube is limited to the amount of current it can draw, the meter movement is electronically protected."

"The maximum voltage applied to the 12AU7 is about 3 volts. Higher test voltages are reduced by a voltage divider which has a total resistance of 10 megohms. An additional 1 megohm in the DC test probe permits measurements to be made in circuits carrying RF voltages with minimal disturbance of such circuits.

"When measuring AC, a 6AL5 twin-diode is used as a half-wave doubler to provide a DC voltage proportional to the peak-to-peak value of the applied AC voltage. This DC voltage is applied through the voltage divider to the 12AU7 causing the meter to indicate as previously described.

"For resistance measurements, a 1.5 volt battery is connected through a string of multipliers and the resistance to be tested, thus forming a voltage divider across the battery. A resultant portion of the battery voltage is applied to the twin-triode. The meter scale is calibrated in resistance for this function."

For less than \$5 accessory probes could be added to the Heath VTVMs. An RF probe extended the RF measurement capabilities to 250 MHz, and DC high voltage probe enabled TV service technicians to measure up to 30,000 volts. The probe multiplied each range by a factor of 100.

HEATH'S AC VTVMs

In September 1951 The Heath Company added the AV-1 to its already successful VTVM offering. This was an AC-only VTVM, sometimes called an audio VTVM. This series remained available from 1951 through 1981 and included the AV1 to AV3, the IM-21, IM-38 and IM-5238. The IM-5238 reached the end of the line in 1981. These instruments featured 10 ranges from 0.01 to 300 volts RMS, had 10 megohms input impedance, and were useful from 10 Hz to 500 kHz. All of them also featured a dB scale.

The IM-21 was a more sophisticated instrument than its predecessor AV-3. The design incorporated a cathode follower stage on all ranges for increased input impedance and a two-stage amplifier for high output stability and linearity. At \$33.95 for the kit, and \$60.25 assembled, it was one of the more expensive instruments sold by Heath.

With introduction of the IM-5238 Deluxe AC Voltmeter in 1976, Heath competed with the Hewlett Packard or Ballantine-type of instrument. Essentially a laboratory meter, this AC voltmeter covered from 1 mV to 300 volts in 12 ranges. Input impedance was 10 megohms shunted by 30 pF with a frequency response from 10 Hz to 1 MHz. Like its much more expensive counterparts, the IM-5238 provided some additional features besides voltage measurements; these were DC output proportional to input volts (1 volt full scale); DC (proportional to log of input volts), 3 volts full scale, and C (amplified output), 1 volt peak-to-peak, full scale.

GETTING TO KNOW YOUR VTVM

"How to Understand and Use Your Vacuum Tube Voltmeter" was the name of a course once offered by the Heath Company. Reportedly the course was used by many schools and individuals for self study. The course combined text and hands-on work. The course assumed no prior knowledge of electronics but also did not "talk down" to the more experienced student. The advertisement noted that a special power supply and component board were included for doing the experiments. VTVM, power supply and circuit board retailed for \$42.

EPILOG

It was a sad day in 1992 when the Heath Company announced that it would no longer offer kits. Countless hams and experimenters would no longer experience the joy of unpacking a Heathkit VTVM kit, laying out the parts and putting these fine instruments together. I once owned a model V-4A but made the mistake of lending it to someone and never got it back. So, when, many years later, I spotted a V-7A at Purchase Radio, I snapped it up and now I treasure it highly. Since then I've added one more, a V-6 in mint condition that I treasure equally. Total investment was no more than \$25 for both.

But, I digress. Now, new Heath enthusiasts have to depend on hamfests to find those classic instruments. What they find will either be immaculate or flogged to within an inch of its life. To paraphrase a famous quote...."The Heathkit VTVM kit is dead, long live the Heathkit VTVM."

The author thanks Chuck Penson, WA7ZZE and historian on Heath electronic products, St. Paul, Minnesota, for his valuable assistance in the preparation of this article.

References

Basic Electronic Test Instruments by Rufus P. Turner, Rinehart & Company, New York, New York, 1958.

The Radio Amateur's Handbook, 36th ed., 1959, American Radio Relay League, West Hartford, Connecticut.

Heathkit Vacuum Tube Voltmeter Model V-7A, condensed manual, 1960, The Heath Company, Benton Harbor, Michigan.

Kurt H. Miska, N8WGW, is an avid test equipment enthusiast whose heart skips a beat when spotting vacuum tube powered analog test equipment at a hamfest or at Purchase Radio in Ann Arbor, Michigan.

QUESTIONS AND ANSWERS FROM OUR READERS

This section will present questions from subscribers for which responses are solicited. If you can help in providing answers, suggestions or just plain good advice - please send them to the editor for inclusion in the next issue of HSN.

Nothing this issue

SHORT SUBJECTS

LITZ WIRE – THE EFFECT OF BROKEN STRANDS

Alan Douglas

Originally printed in the Delaware Valley Historic Radio Club “Oscillator” – July 1997 titled “Chestnuts Roasting on the Internet” - reprinted with permission of the author

“Everyone” knows that if you wind an RF coil of litz wire, if just one strand breaks, the “Q” [quality factor] goes to pot. This old chestnut just won’t go away, as evidenced by present-day techno-chatter on the Web.

John Morecroft tried. From the second edition (1928) of his *Principles of Radio Communication*, pg 172: “Analysis shows no logical reason for such an effect.” He proceeds to give his experimental results which indeed show that the effect is negligible. Again, in 1933 the RCA License Laboratory made a study, using three- and seven-strand litz, and got the same results. Here is the report as condensed for *Electronic* magazine in Dec. 1933: One broken strand out of seven drops the “Q” by two percent. Wow!

Effect of broken strands

When using fine wire, e.g., No. 41, it is comforting to know that a broken strand is not of great importance, particularly when there are seven or more strands. When a break occurs, it is most likely to be found at the end of the lead where a mechanical operation prepares the wire for tinning. The following table shows the percentage loss of Q due to broken strands:

Number of broken strands	I.F. =>	450 kc	450 kc.	260 kc	260 kc
	L =>	2 mh.	2 mh.	4 mh.	4 mh.
	Wire =>	7/41	3/40	7/41	3/40
1	3	11	2	19
2	5	30	5	49
3	7
4	10
5	18
6	33	..	41	..

It is evident that the effect of broken strands is far less than proportional to the number of broken strands. One broken strand is of no practical importance. The above data apply to broken strands at the high end of a coil. Broken strands at the low end of a coil are found to have practically the same effect.

As a conclusion, it is fair to state that 3/40 is favorable when very *small* i-f coils are desired; 7/41 is desirable when medium size are in order; 10/41 is worthwhile only when *large* coils can be tolerated, at i.f.

At r.f., 7/41 and 10/41 are worthy at the low frequency end of the broadcast spectrum, but at 1,500 kc. no Litz wire tested in the study is to a worthwhile degree advantageous over solid wire.

The effect of a broken strand is unimportant when using 7/41 or 10/41, and not serious when using 3/40. A broken strand is not the equivalent of a removal of that strand. Despite the break, the strand still assists the process of conduction through the coil.

Considering both i.f. and r.f., 10/41, 7/41 and 3/40 appear to be three suitable Litz wires for general use in present-day receivers. The inclusion of 10/41, if not definitely logical at i.f. is desirable as regards r.f.

It is not important to make an extensive study of Litz wire at 175 kc. Only at high intermediate frequency – such as 450 kc. and at r.f. is Litz wire worthwhile.

Anybody with a Q-meter and some time can do the same. I did it and guess what? I got the same results!

ADDITIONAL MANUAL SOURCES – *Geoff Fors Hallicrafters* – Ardco Electronics, P.O.Box 95, Berwyn IL 60402 offers crisp photocopies of manuals for nearly every Hallicrafters product. Prices are reasonable and generally below the competition, service is fast. Send SASE with inquires for specific manuals, no catalog. National – Maximilian Associates, 11 Plymouth Lane, Swampscott MA 01907 is run by Max Fuchs, a former National employee. He offers what presumably are photocopies of the service manuals for most items made by National, including pre-war sets. Send SASE for his price list

PUBLICATIONS OF INTEREST

Nothing this issue

WANTED TO BUY / SELL / TRADE / WHATEVER

FOR SALE Are your SP-600JX dials yellowed and/or chipped? Restore your SP-600JX xx and replace those yellow or chipped dials. I have had some SP-600JX dial overlays made. These were made by a photographic process complete with the raised lettering on glossy, white stock and are absolutely top quality. Best of all, your dials can be re-done with out defacing the original dial face. Simply turn the dials around and install the new overlays. Nothing can be easier. There are two styles: One is a very fine lettering font which is found on the JX-1 etc. The second is a more bold font which I have seen on the JX-17, 21 and 26. Cost is approximately \$50 for both the dial and logging scale. If interested, send an E-Mail to: crippel@usa.net or write: Chuck Rippel, 2341 Herring Ditch Road, Chesapeake, VA 23323-6419 (757) 485-9660

FOR SALE Stainless Steel R390A front panel hardware kits. With the treatment given R390A's by the military, most of the front panel hardware on the radios can stand replacement. Front panel screws have oxidized and their slots rounded from use. I have complete kits of all R390A front panel hardware available with a keyed placement pictorial. These parts are all brand new stainless steel and are as original. The kit even includes the special meter screws and 5 conical lock washers for the center front panel screws. \$25 each set. Contact Chuck Rippel, address above.

FOR SALE Rebuilt R390A Filter Caps. The most common single failure in the R390A is becoming the 2 electrolytic capacitors on the power supply. The 2 section 45mfd and 3 section 30mfd units fail and cause low voltage, power supply strain and static/noise in the radio. I can rebuild yours with quality US made, new (not New Old Stock) Mallory components for \$70/pr. Remember, electrolytic caps fail from age, not use. NOS caps are usually bad caps. As most R390A filter caps are now leaking, I have found the results to be immediate with cleaner audio and a reduction of noise being the benefit. The technique is somewhat difficult and is one I was compelled to develop after Frontier Capacitor found they were difficult and declined to do mine. Your caps are returned looking original and plug right back in the radio. An individualized specification sheet for your capacitors is included. Contact Chuck Rippel, address above.

WANTED R390 in good working condition. Also looking for table mount cabinets for 51J-3 and Navy RCH. Robert Harding, KC5LHR, 1321 Monte Largo Dr NE, Albuquerque NM 87112; (505) 291-0950 or e-mail Robert.Harding@abq.com

WANTED Subscriber John Gillespie is rebuilding a BC-348Q with some damaged coils. He is looking for a coil rewinding service or a coil winder. Alternatively, anyone who is parting out a BC-348Q should contact him at 55 West 4th Street, Hamilton, Ontario L9C 3M5.

EDITOR'S AND PUBLISHER'S CORNER

Ever experimenting, HSN No.44, as you can plainly see, is part of an ongoing effort to make HSN a little more 'user-friendly'. By moving most of the 'fine print' and this column to the last page you can get right into the 'meat' of the feature article right away.

Some items which are expected to be in HSN No. 45 include additional parts/tube vendors, some more 'snippets' about the SP-600, a fix to the R-390A antenna trimmer, and more on tube shields for the R-390A. I continue to browse the Boatanchors mail list as well as the new R-390 list, always looking for new material. There have been several items of interest to HSN subscribers that I will need to follow up on with the authors – my policy to get author approval of all communications has not changed.

SUBSCRIPTIONS: \$5 for 4 issues (3 issues published per year).

BACK ISSUES: \$1 each, all issues currently available - minimum order is 5 issues.

SELECTED REPRINTS: The best of *Hollow State Newsletter* from issues 1-4, \$1; Rebuild notes for the URM-25D, \$1.

INDEX: Issues 1 through 35 (9 pages - topics by Issue/page number) - \$1

PAYMENT: Send check or money order payable to the publisher, **Ralph Sanserino**. Prices apply to the USA, Canada, and Mexico. Double quoted prices to other areas. Checks and money orders must be in USA funds payable in USA clearinghouse format.

All submissions for possible publication in *HSN* should be sent to the Editor - materials will not be returned unless requested and with sufficient postage included. The Editor and Publisher assume no responsibility for the accuracy or safety of untested modifications or the reliability of suppliers of services, parts, or equipment mentioned in *HSN*. Opinions expressed in *HSN* belong to the individual contributors and do not necessarily reflect those of the Editor or Publisher. Copyrighted materials from trade journals, magazines, etc. cannot be reproduced without accompanying reprinting release; however, clippings are appreciated and will be appropriately paraphrased if used. Questions, comments and inquiries concerning *HSN* are welcome. Submittals selected for publication are subject to editing. **All articles and information shared through this newsletter may be reprinted only with permission of the author.**
