

# COLLINS DESCRIPTIVE SPECIFICATIONS

CDS 129

Copy No. 9

DESCRIPTIVE SPECIFICATIONS

for

COLLINS TYPE 205E 40 KW CW TRANSMITTER

June 22, 1948

## COLLINS RADIO COMPANY

C E D A R . R A P I D S , I O W A , U . S . A .

DESCRIPTIVE SPECIFICATIONS

for

COLLINS TYPE 205E-1 40 KW CW TRANSMITTER

Collins Radio Company  
Cedar Rapids, Iowa

## GENERAL DESCRIPTION

A high power general purpose communications transmitter capable of telegraphic on-off or frequency shift keying at speeds in excess of 400 words per minute at a power output level in excess of 50 kilowatts or alternately capable of amplifying the power output of a single side band transmitter (Western Electric D156,000 or equivalent) to a peak envelope power in excess of 30 kilowatts is described herein. This transmitter includes all of the equipment necessary to take power from the 230 volt, three phase, 60 cycle power line and deliver radio frequency energy to the terminals of a 600 ohm transmission line at any desired frequency between the limits of 4.0 to 26.0 megacycles. This equipment is designed in accordance with the best acceptable practice for military and commercial shore station operation.

This transmitter consists of a Collins 205D-1 unit (15 KW CW or 8 kw peak envelope single side band) followed by a grounded grid power amplifier stage. The design is such that the 205D-1 unit may be used independently or as a driver for the power amplifier or alternately the power amplifier can be added to any Collins 205D-1. To accomplish this end, the power amplifier is a complete unit requiring only control circuit and drive connections from the 205D-1 transmitter.

## ELECTRICAL SPECIFICATIONS

1. Power output . . . . . 40 Kw continuous (class C operation)  
30 Kw peak linear amplifier  
(class B operation).
2. Frequency range. . . . . 4.0 to 22.0 Mc continuous at full  
rated power. 22.0 to 26.0 Mc  
with linear reduction in power to  
75% of rated at 26.0 Mc.
3. Frequency changing method. . . . . Continuously variable tuning ele-  
ments, motor driven.
4. Keying capability. . . . . 400 wpm maximum.
5. Keying input voltage . . . . . 20 to 150 volts DC.
6. Keying input circuit impedance . . . . . 25,000 ohms.
7. Normal radio frequency load impedance. Balanced 600 ohms with 2:1 maximum  
SWR.
8. Primary line . . . . . 230 volts, three phase.
9. Primary line frequency . . . . . 57 to 63 cps.
10. Primary line voltage tolerance . . . . .  $\pm 10\%$ .
11. Primary power input (approximately). . . . . Key up - 14.5 KVA.  
Key down - 85.0 KVA.
12. Carrier frequency stability in terms of maximum frequency deviation pro-  
duced by the following causes:

Keying . . . . .	0.0001%
Transmitter tuning (except oscillator) . . . . .	0.0001%
Power output adjustment. . . . .	0.0001%
Oscillator tube changes. . . . .	no specification.
Other tube changes . . . . .	no specification.
$\pm 10\%$ supply line voltage variation . . . . .	0.0001%
Permanent change in ambient temperature - per degree Centigrade change. . . . .	0.0002%
30 to 95% humidity variation . . . . .	0.0002%
Locked Key - during first 5 minutes. . . . .	0.0002%
5 minutes to 2 hours after start. . . . .	0.0002%
Change from locked to intermittently keyed	0.0002%

### 13. Frequency monitoring Provisions:

A front panel jack is provided to deliver a sample of the grid voltage of the first frequency multiplier (crystal frequency) to the external frequency monitor. A second jack is provided for headphone connection to the transmitter terminal strip.

14. Hum and Noise Level: Less than 1% equivalent amplitude or phase modulation.

### 15. Magnitude of Radio Frequency Harmonics and/or Spurious Radiations:

No minimum standard is specified. They are maintained at the lowest value consistent with good engineering practice.

16. Interference to Co-channel Reception:

Sufficient shielding is provided around the stages preceding the keyed stage to reduce direct radiation to a negligible value.

## ELECTRICAL DESCRIPTION

### 1. Tube Complement:

Oscillator . . . . .	6AK5
First Buffer . . . . .	6AG7
Second Buffer. . . . .	6AG7
Keyer. . . . .	12AU7
First frequency multiplier . . . . .	807
Second frequency multiplier. . . . .	807
Driver . . . . .	4-250A
Intermediate power amplifier . . . . .	(2) 3X2500A3
Power amplifier. . . . .	(6) 3X2500A3
Low voltage rectifier. . . . .	(2) 3B28
Bias supply rectifiers . . . . .	(6) 3B28
I.P.A. power rectifier . . . . .	(6) 4B32
Power amplifier power rectifier. . . . .	(12) 4B32
Oscillator voltage stabilization . . . . .	(2) VR-150

2. Expected Tube Life: Greater than 2000 hours in normal operation.

3. Block Diagram: Refer to the preceding pages.

4. Schematic Diagram: Not included.

### 5. Exciter:

The exciter consists of those tubes and circuits which comprise the oscillator, the first buffer, the second buffer, the first frequency multiplier, and the keyer stages. These circuits and tubes are enclosed in sturdy metal boxes to provide the required shielding. These units are readily removable sub-assemblies which are connected to the power and other external circuits through suitable pin type connectors.

The oscillator is a modified Pierce type with no tuning adjustments. 2.0 to 4.33 megacycle crystals mounted in Bliley type BC-46 holders are used in this oscillator. Switching provision is made for selecting any one of six positions. Since these Bliley type holders have self-contained heating ovens, no other provision for oscillator or crystal heating is made.

Isolation of the crystal oscillator from the effects of loading, switching, etc. of subsequent stages is provided by a 6AG7 first buffer. This stage is operated as a wide band cathode follower to feed power into a low impedance circuit. This low impedance circuit contains switching facilities for feeding the oscillator output to either a 50 or 80 ohm coaxial line external to the transmitter or the input of the second buffer. The input of the second buffer is designed to be switched to take power either from the internal oscillator or from a 50 to 80 ohm coaxial line from an external oscillator.

The second buffer is a 6AG7 broad band untuned amplifier which provides required voltage gain from the low impedance coupling and switching circuit to the grid of the first frequency multiplier. This stage is also the main keyed stage.

The first frequency multiplier, an 807, has its grid, screen, and cathode circuits enclosed in a good shielding enclosure with the second buffer and keyer. This stage is also keyed simultaneously with the first buffer to insure a minimum of feed through with the key open. The output circuit for the frequency multiplier is the first tunable circuit in the transmitter and has a tuning range of 4.0 to 13.0 megacycles.

Power for this exciter is obtained from the 600 volt low voltage supply which also supplies power for the second multiplier and the driver amplifier screen.

#### 6. Frequency Multiplier.

Two frequency multiplying stages are incorporated in this transmitter. The first multiplier provides output at either two or three times crystal frequency. The second multiplier, which is also an 807, utilizes multiplying factors of one or two so that its output frequency is the required carrier value. This means the frequency multiplier output frequency range will be from 4.0 to 26.0 megacycles.

Both multiplier stages utilize continuously variable tuned circuits.

This second multiplier is mounted as an integral part of the transmitter cabinet and adjacent to the driver amplifier.

#### 7. Driver Amplifier.

A single type 4-250A/5D22 in a conventional single end to push-pull circuit is used to drive the power amplifier. This stage operates at 4000 volts anode potential, which is obtained from the main power supply. Minimum circuits loss between this stage and the power amplifier is insured by the use of a single coupling circuit which is made possible by the proper selection of the mechanical arrangement of this circuit.

#### 8. Intermediate Power Amplifier.

Two high transconductance forced air cooled triode tubes in a push-pull circuit constitute the intermediate power amplifier. The tube around which this circuit is designed is the Eimac type 3X2500A3.

By utilizing this tube with its extremely high transconductance, very high tube efficiency is obtained with relatively low anode voltages. Although tube efficiencies in the order of 85% or greater are readily obtainable from this tube, the design is based on a 68% amplifier (including tank circuit) efficiency. This is conservative design and should be exceeded under normal operating conditions.

The tank circuit for this amplifier is continuously variable with a motor driven adjustment. Magnetic coupling to the antenna loading circuits is made readily adjustable for ease of tuning and maintenance of power.

The filaments of this intermediate power amplifier are operated from high reactance transformers which provide automatic current limiting on start-up and thus eliminate any kind of step starting system.

The grid circuit of this intermediate power amplifier contains provision for coupling the output of a Western Electric type D156,000 twin channel transmitter. 200 ohm balanced coaxial input is provided. One kilowatt peak power from the D156,000 transmitter is required.

Means are also provided for adjusting the bias and loading of this amplifier for linear amplifier operation.

#### 9. Power Amplifier.

Six type 3X2500A3 tubes in a push-pull grounded grid circuit constitute the power amplifier stage. The tubes are identical to those used in the intermediate power amplifier. Between 4.0 and 22.0 Mc this amplifier is capable of delivering in excess of 50 Kw useful power for CW operation and is therefore operated very conservatively at 40 Kw output. When adjusted as a linear amplifier for twin channel or single side band operation, a peak useful power in excess of 30 Kw is available. The amplifier is designed to operate satisfactorily and conservatively at a top frequency of 26.0 MC, however, tank circuit considerations indicate that a uniform power reduction between 22.0 and 26.0 Mc. to 75% of rated power is desirable to insure conservative operation at the highest operating frequencies.

The tank circuit for this amplifier is continuously variable with a motor driven adjustment. Magnetic coupling to the antenna loading circuit is readily adjustable for ease of tuning and maintenance of power.

The filaments of the power amplifier are operated from high reactance transformers which provide automatic current limiting on start-up and thus eliminate any kind of step starting system.

Provision is made for adjusting the bias and loading of this amplifier for either class C or class B linear operation.

#### 10. Power Supplies.

The main power supply which supplies the DC power to the power amplifier, is completely independent of the supplies for the intermediate power amplifier and exciters. Provision is made for interconnecting the controls of the two supplies, however. This supply utilizes 12 type 4B32\* tubes in a conventional three phase, full wave rectifier circuit.

\* Type 3B28 and 4B32 tubes are Xenon filled rectifier tubes which are very non-critical of operating temperature. They have the same current and voltage ratings as 866A and 872A tubes and are directly interchangeable therewith.



A high current bias supply utilizing 4 type 3B28\* rectifiers provides bias for the power amplifier independent of the bias supply in the intermediate power amplifier.

The power supply, which furnishes DC voltage to the intermediate power amplifier and its driver, is a conventional three phase, full wave rectifier circuit utilizing 4B32 tubes.

The DC filters for the main power supply and the intermediate power supply are designed with inductance and capacity sufficient to reduce the peak value of the AC ripple voltage to 1.0% of the DC voltage. This design will permit off-on keying at the maximum specified speed of 400 words per minute.

A high current bias supply utilizing 2 types 3B28 rectifiers in a single phase, full wave circuit is provided. This supply delivers 450 volts at a maximum current of 0.8 amperes to provide bias for all keyed stages.

600 volts at 0.5 amperes for operation for all low level stages is provided by a single phase, full wave supply utilizing 2 type 3B28 rectifiers.

\* Type 3B28 and 4B32 tubes are Xenon filled rectifier tubes which are very non-critical of operating temperature. They have the same current and voltage ratings as 866A and 872A tubes and are directly interchangeable therewith.

## CONTROL AND SUPERVISION FACILITIES

### 1. Operating Equipment.

#### (a) Filament and Blower Start-Stop.

Single pole, single throw toggle switches are located on the front panel of each unit in this transmitter. These switches serve the dual function of filament and blower control and emergency shut down. They directly control the filament contactors for the radiation cooled tubes which in turn control the contactors for the forced air cooled tubes and their associated blowers. All forced air cooled tube circuits are interlocked through the blowers and filament contactors to preclude the possibility of application or maintenance of any potentials in the absence of proper cooling air. Complete filament circuit fault protection is provided by a system of circuit breakers and fuses. The use of fuses is kept to a minimum.

Voltage regulating transformers are used to maintain proper primary voltage for all but the intermediate and final power amplifier filament transformers. Primary tap switches and rheostats are provided for control of these power amplifier filaments. All power amplifier filament transformers are of the current limiting type.

#### (b) Plate Voltage Start-Stop.

A momentary contact type start button and a similar stop button are located on the front panel of each unit in this transmitter. The controls on the panels of the two units which comprise the exciter and intermediate power amplifier control the low and high voltage DC in only these units while the controls on the two units which comprise the final power amplifier control the DC voltages in the entire transmitter.

A control circuit in which these start-stop switches are incorporated is completely independent of, though interlocked with, the filament and blower circuits in the transmitter. These circuits are adequately protected by circuit breakers.

Both high voltage power supplies utilize Westinghouse Deion type motor operated breakers for their start-stop contactors as well as for overload protection. The normal AC overcurrent trips in these breakers are augmented by undervoltage release coils which will instantaneously trip the breaker if the coil current is interrupted. Very high speed overload protection is thus obtained by locating the overload relay and certain control circuit contacts in series with this undervoltage release coil.

#### (c) Automatic Restarting Following Overload.

Provision is made for automatic restarting of the high voltage power supply following an overload trip-out. This restarting feature is automatically disabled for the first 30 seconds following manual start up so that an overload will cause a lock-out during this interval. Overloads occurring subsequent to

this initial 30 second period will start the automatic reclosure circuit which will in turn produce up to eight consecutive reclosures before final lock-out. Both the number of consecutive reclosures and the time during which they must occur to cause a lock-out are adjustable.

## 2. Indicating Instruments.

Weston 730 series rectangular meters with illuminated scales are used throughout this transmitter. These meters are located at average eye level on the front panel of the transmitter. A total of fifteen meters on the front of the transmitter, plus two radio frequency meters which are to be mounted external to the transmitter, are provided for metering the following circuits.

The following meters are located on the Intermediate Power Amplifier Cabinet:

1. I.P.A. total plate current.
2. I.P.A. multimeter (5 pos. selector switch).
  - (a) I.P.A. #1 cathode current.
  - (b) I.P.A. #2 cathode current.
  - (c) I.P.A. total grid.
  - (d) I.P.A. #1 grid current.
  - (e) I.P.A. #2 grid current.
3. Driver cathode.
4. Exciter and driver multimeter #2 (5 pos. selector switch).  
(Common with multimeter #1).
  - (a) Driver grid current.
  - (b) 2nd mult. grid current.
  - (c) 1st mult. grid current.
  - (d) Right I.P.A. R.F. Drive voltage.
  - (e) Right I.P.A. R.F. Output voltage.
5. Exciter and driver multimeter #1 (5 pos. selector switch).  
(Common with multimeter #2).
  - (a) 2nd mult. cathode current.
  - (b) 1st mult. cathode current.
  - (c) Low voltage DC voltage
  - (d) Left I.P.A. R.F. drive voltage
  - (e) Left I.P.A. R.F. output voltage

The following meters are located on the I.P.A. Rectifier and Control Cabinet:

1. High voltage DC.
2. Primary line AC multimeter (5 pos. selector switch).
  - (a) Phase 1 voltage.
  - (b) Phase 2 voltage.
  - (c) Phase 3 voltage.
  - (d) Regulated filament Buss No. 1 voltage.
  - (e) Regulated filament Buss No. 2 voltage.

3. I.P.A. filament multimeter (2 pos. selector switch  
common with line mult. switch).
  - (a) I.P.A. #1 fil. voltage.
  - (b) I.P.A. #2 fil. voltage.

The following meters are located on the Final Power Amplifier Cabinet:

1. Total P.A. plate current.
2. Total P.A. grid current.
3. P.A. multimeter #1 (4 Pos. selector switch).
  - (a) Left P.A. R.F. drive voltage.
  - (b) Right P.A. R.F. drive voltage.
  - (c) Left P.A. R.F. plate voltage.
  - (d) Right P.A. R.F. plate voltage.
4. P.A. multimeter #2 (8 pos. selector switch).
  - (a) Left P.A. grid current.
  - (b) Right P.A. grid current.
  - (c) P.A. #1 cathode current.
  - (d) P.A. #2 cathode current.
  - (e) P.A. #3 cathode current.
  - (f) P.A. #4 cathode current.
  - (g) P.A. #5 cathode current.
  - (h) P.A. #6 cathode current.

The following meters are located on the P.A. Rectifier Cabinet:

1. P.A. plate voltage.
2. P.A. filament multimeter (2 Pos. selector switch).
  - (a) Left P.A. fil. voltage.
  - (b) Right P.A. fil. voltage.
3. Primary line AC multimeter (5 pos. selector switch common with  
P.A. fil mult. switch).
  - (a) Phase 1 voltage.
  - (b) Phase 2 voltage.
  - (c) Phase 3 voltage.
  - (d) Regulated filament Buss No. 1 voltage.
  - (e) Regulated filament Buss No. 2 voltage.

Running time meters are provided in each rectifier and control bay for individually recording the elapsed hours of filament operation and hours of operation with plate voltage applied. These meters are located inside of non-interlocked doors.

### 3. Indicating Lamps.

Four colored indicating lamps using 6 watt, 115 volt bulbs are located on the front panels of each unit of the transmitter adjacent to the filament and plate start-stop switches. The indication and color for these lamps is as follows:

Driver (205D) Unit.

- (a) Filaments and blower "on" with air interlock closed - amber.
- (b) Bias and low voltage "on" (L.V. pilot on rectifier cabinet, bias pilot on R. F. cabinet) . . . . . - green.
- (c) High voltage DC "on" . . . . . - red.
- (d) DC supply breaker tripped and auto reset . . . . . - amber.

Power Amplifier Unit.

- (a) Filaments and blowers "on" with air interlock closed- amber.
- (b) Bias voltage "on". . . . . - green.
- (c) High voltage DC "on" . . . . . - red.
- (d) DC supply breaker tripped and auto reset . . . . . - amber.

Two 50 watt lamps and ruby globes are supplied with the equipment. A properly fused circuit to connect these lamps to the main plate supply primaries is also provided. Placement of the lamps is then at the customer's option in installation.

A warning alarm is provided to sound an audible signal whenever the transmitter has a power supply lock-out following an overload. A pair of terminals on the terminal board are connected into this alarm circuit so that they will be energized with 230 volts simultaneously with the operation of the alarm. This voltage may then be used to operate any external alarm warning device which may be desired.

4. Frequency Changing Provision.

There are nine continuously variable tuned circuits in this transmitter. All of these circuits are remotely adjusted through individual simple electrical servomechanisms. Six small control knobs for these circuits are conveniently located on the control panel behind the small access door in the front of the driver unit. Three additional controls are located behind the small access door on the power amplifier unit. Each of these servo systems contains a simple two stage amplifier to insure a high degree of accuracy between the final position of the driven circuit and the manual position of the manual control. Approximately one minute is required to drive the power amplifier tank circuit through its entire range.

5. Tune-Operate Controls.

The intermediate power amplifier and its exciter (205D Unit) is provided with a three position tune-operate switch. This switch performs the following functions:

- (1) A low voltage position in which position the high voltage supply is locked off.
- (2) A high voltage tune position in which series resistors are inserted in the high voltage supply primary leads.
- (3) An operate position.

The power amplifier is provided with a front panel means for selecting reduced plate voltage for tuning or reduced power operation.

#### 6. Automatic Protective Equipment.

(a) Primary line breakers of the manual switch type are used to protect all branch circuits connected to the transmitter primary power terminals. These breakers provide adequate protection against overload of any otherwise unprotected circuits with which they are loaded. In addition, they provide a convenient means of manually isolating each branch circuit for service or inspection. These breakers are accessibly located behind non-interlocked front doors.

The high voltage power supplies are likewise protected by electrically operated breakers. These are Westinghouse Deion type with thermal magnetic over-current trips for AC overload protection and under-voltage release coils for DC overload protection. On this type breaker the under-voltage release must be continuously excited to hold the breaker closed. Very high speed DC overload protection is provided therefore by locating the DC overload relay contacts in series with this under-voltage release. This provides an interrupting speed of less than .03 seconds (2 cycles) after parting of the overload relay contacts and is perhaps the highest speed mechanical installation that is practical.

#### (b) Air Interlocks.

The intermediate and final power amplifiers in this equipment utilize forced air cooled tubes. Cooling air is furnished by high pressure motor driven blowers. The power amplifiers are cooled by separate blower systems, and are therefore capable of independent operation. In each case, however, an interlock switch is provided which will be actuated by the air flow and prevent application of any potentials to the amplifier tubes until a safe volume of air is passing through the tube radiators. Failure of air for any cause whatsoever will then cause an immediate shut down of all equipment supplying power to these tubes.

#### (c) Door Interlocks.

All access doors to enclosures where potentials of greater than 250 volts are accessible are electrically interlocked to prevent the application of these voltages while the doors are standing open or to remove these voltages if the doors are opened while power is "on".

#### (d) Emergency Shutdown Provisions.

The type of filament start-stop switches and their location in the circuit are such that they become the best possible emergency "off" switches. These consist of toggle switches prominently identified by red handles. Operating these toggle switches to the "off" position directly breaks the operating voltage to the main filament contactor which in turn removes power from all other circuits in the particular section of the transmitter with

which it is associated. The blowers and their control circuits are excluded from this emergency shutdown feature however to prevent the immediate termination of cooling air to the tubes.

## MECHANICAL DESCRIPTION

### 1. Enclosures.

This transmitter is contained in a four cabinet enclosure. These enclosures are made of heavy gauge sheet metal with large front and rear access doors. They are of modern Collins styling similar to that used for the Collins Broadcast and FM transmitters.

The complete transmitter requires a floor space of 15 feet 1/4 inches front width by 54 inches depth by 79-5/16 inches high. Only the final power amplifier cabinet requires the 54 inch depth while the remainder of the cabinets require 37-1/2 inches depth. An additional clearance for door swing of 21-1/2 inches rear and 43 inches front is required.

### 2. Location of Controls.

Only those controls normally associated with starting and stopping this transmitter are located on the external part of the front panel. These are the filament and plate voltage controls. All other controls are located on internal panels which are available through non-interlocked doors. Those controls which require access during normal operation for routine checking, etc. are accessible through a small door in the center of the lower front main access door. Some controls associated with frequency changing and other infrequently used circuits, may require opening of the lower front door for their access. This door, however, is not interlocked as it does not provide access to voltages greater than 250.

### 3. Accessibility of Equipment.

Location and mounting of component parts follows current commercial practice which provides ready access to all parts which may require servicing or replacement. Large front and rear doors provide the necessary access. Removal of side panels is not required for accessibility.

### 4. Terminal Location.

Primary power and inter-connecting control wiring terminals are located in the bottom section in the rear portion of each cabinet. They are accessible through the rear doors. Large opening in the floor of the cabinets provide access to external wiring or integral wiring ducts for adjacent unit connections.

Radio frequency power output terminals are located in the center of the top cover on the radio frequency units. These terminals are spaced for 600 ohm line connection. Adjacent to these terminals is a provision for mounting the radio frequency line ammeter sub-assembly.

### 5. Personnel Protection.

Every door which provides access to voltages in excess of 250 is both electrically and mechanically interlocked. The electrical interlock has been



previously described. Mechanical interlocking is provided to mechanically short to ground all DC or AC voltages which could conceivably exist either during normal operation or failure of the electrical interlock. These mechanical shorting devices are strategically located so as to be directly visible after opening a door and preparing to enter the enclosure.

#### 6. Equipment External to Enclosure.

The power transformers for both the intermediate power amplifier and the final power amplifier are supplied for external mounting. They are three phase, dry type, air cooled units with class B insulation and with a maximum temperature rise of 80°C above ambient. They are enclosed in protective sheet metal housings which are to be grounded upon installation. Provisions are made for conduit or flexible tubing connections to these enclosures. These two units are rated 24 KVA and 65 KVA.

Two additional sheet metal enclosures for housing the power transformer primary current carrying circuits are also supplied for external mounting. They are wall mounted with locking front access doors. These enclosures contain the main circuit breakers, voltage changing switches, and the series line resistors with their shorting contactor.

## COMPONENTS

The components to be used in this equipment are best quality units which meet standards for shore station operation.

Insulation for all radio frequency circuits is high grade ceramic while either ceramic or phenolic insulating material is used in AC and DC power circuits. Voltage stresses across insulating surfaces are held to accepted safe values after due consideration of the effects of humidity, altitude, and insulating medium.

Shielding and wiring are installed in accordance with the best accepted practice.

All components are legibly marked with their circuit symbol numbers in such a manner as to be readily visible without removing components.

Components and insulation are selected to provide satisfactory operation at relative humidities up to 95% and ambient temperatures to 50°C. In addition, breakdown voltage ratings of insulation and air capacitors are sufficient for operation at 6,000 feet above sea level.

The components and mechanics of this unit are sufficiently rugged to withstand shock and vibration normally encountered in shipment, installation, and subsequent operation.

## SPECIAL CONNECTIONS AND PROVISIONS

### 1. Test Key.

A test key is provided for operation in the key-down position during tune up and other adjustments. This is a three position key with the center position being the normal key-open position. This key will simulate key-down conditions when operated to either side of center position. One side, however, is momentary contact only while the other side is a locked position.

One of these keys is installed on each of the four units comprising this transmitter. They are located on the control panels accessible through the small access doors.

### 2. Frequency Monitoring Provisions.

A sample of the exciting voltage for the 6AG7 buffer amplifier which is the oscillator output, is fed through coaxial cable to a coaxial jack to which an external cable may be connected. A phone jack is mounted on the internal panel accessible through the small door of the exciter and is directly connected to terminals on the regular terminal strip. This jack is provided for aural checking of the frequency monitor output from the front panel of the transmitter.

### 3. Automatic Shut Down.

Provision is made to shut down the main DC power supplies automatically in the event that no keying impulses are applied to the input circuit for a period of 15 minutes. This feature can be disabled at will by the transmitter operator.

### 4. Provision for Frequency Shift Keying.

This transmitter is designed as a frequency multiplier and amplifier to follow any 2 to 4.5 megacycle exciter which is capable of supplying the required 10 to 20 volts of drive. To accomplish this end, provision has been made to mount standard rack mounting equipment on a special rack which is located in the lower front of the R.F. cabinet of this transmitter. This special rack or frame is so mounted that it will swing outward to provide access to the rear of the equipment mounted thereon. It provides side by side mounting for two groups of rack mounting equipment with 24-1/2 inches of vertical rack each. 10-1/2 inches of this space is occupied by two 5-1/4 inch units which contain the servo control amplifiers for the tuning motors. The space behind this rack is sufficient to accommodate 13-5/8 inch depth units with rear cable connections.

The transmitter is supplied for on-off keying with only the crystal oscillator unit mounted in this rack. The additional space may be used however in any of a number of ways to provide alternate methods of excitation. If provision for operation from external equipment with switching facilities for their selection is required, a simple switching panel can be mounted in this space.

For operation with frequency shift keying the Collins 709A-1 or 709A-2 frequency shift keyer and power supply can be mounted on this rack and added between the crystal oscillator and the transmitter input.

#### 5. R.F. Input Switching.

An R.F. input switching means is provided by a coaxial jack panel and interconnecting jumper or "patch" cables for selecting the desired exciting unit. This switching arrangement provides complete flexibility of the equipment mounted in the transmitter.

For multiple frequency operation the crystal oscillator can be augmented by the Collins 708A-1 or 708A-2 variable frequency oscillator unit which will also mount on this rack.

Many other alternatives are possible with this very flexible design.

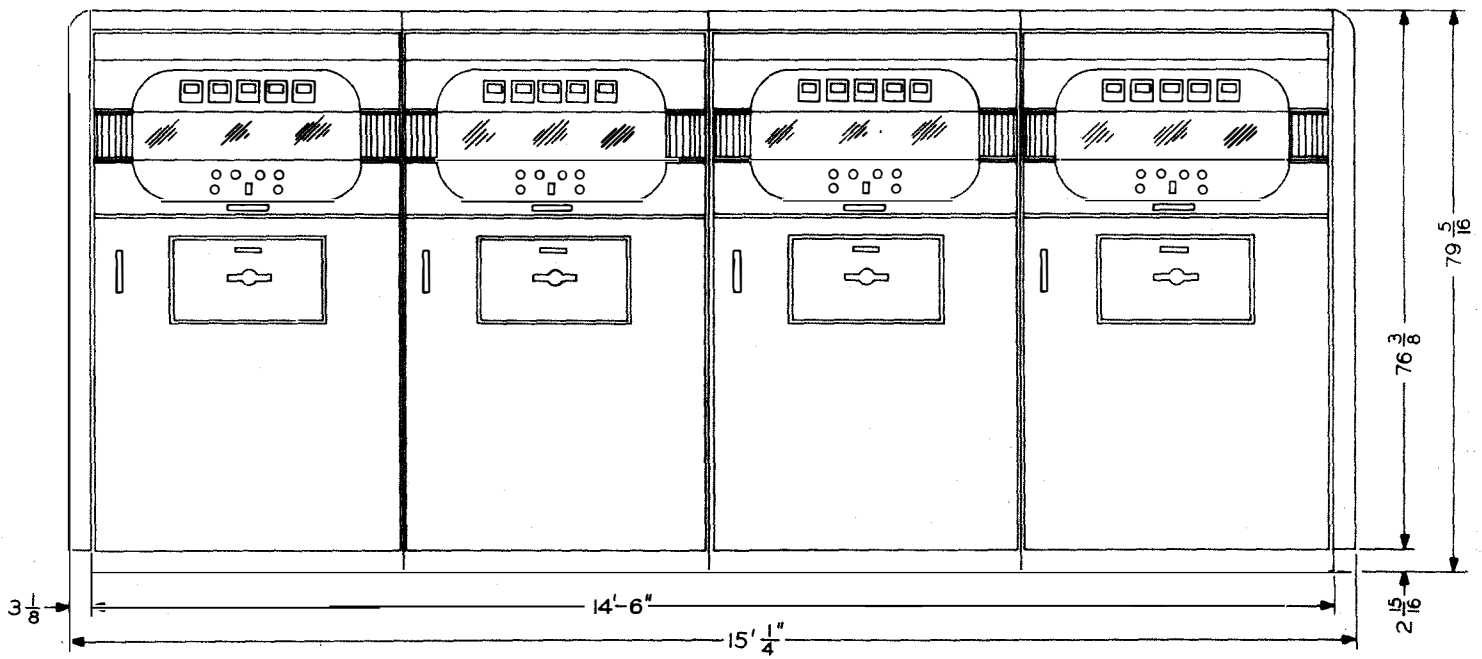
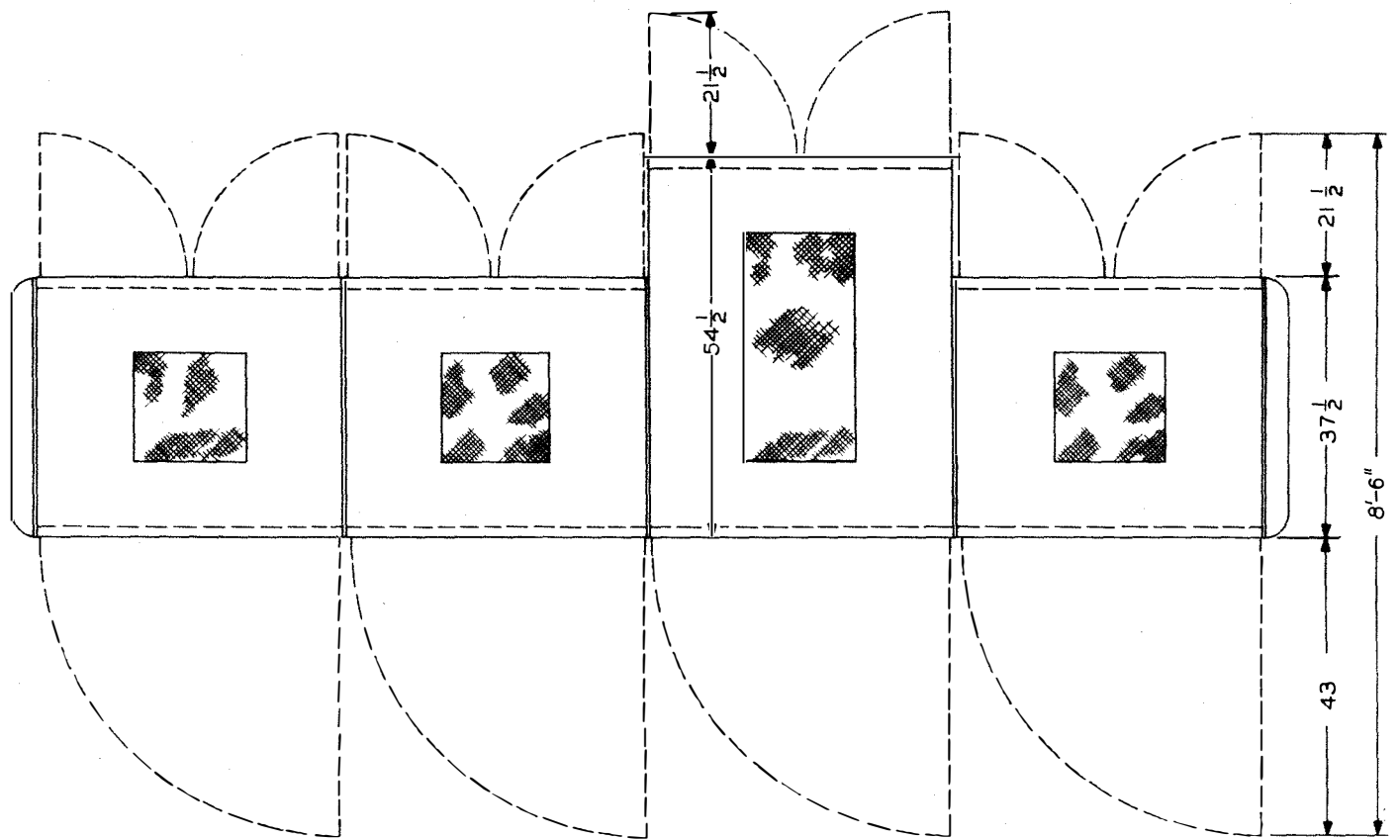

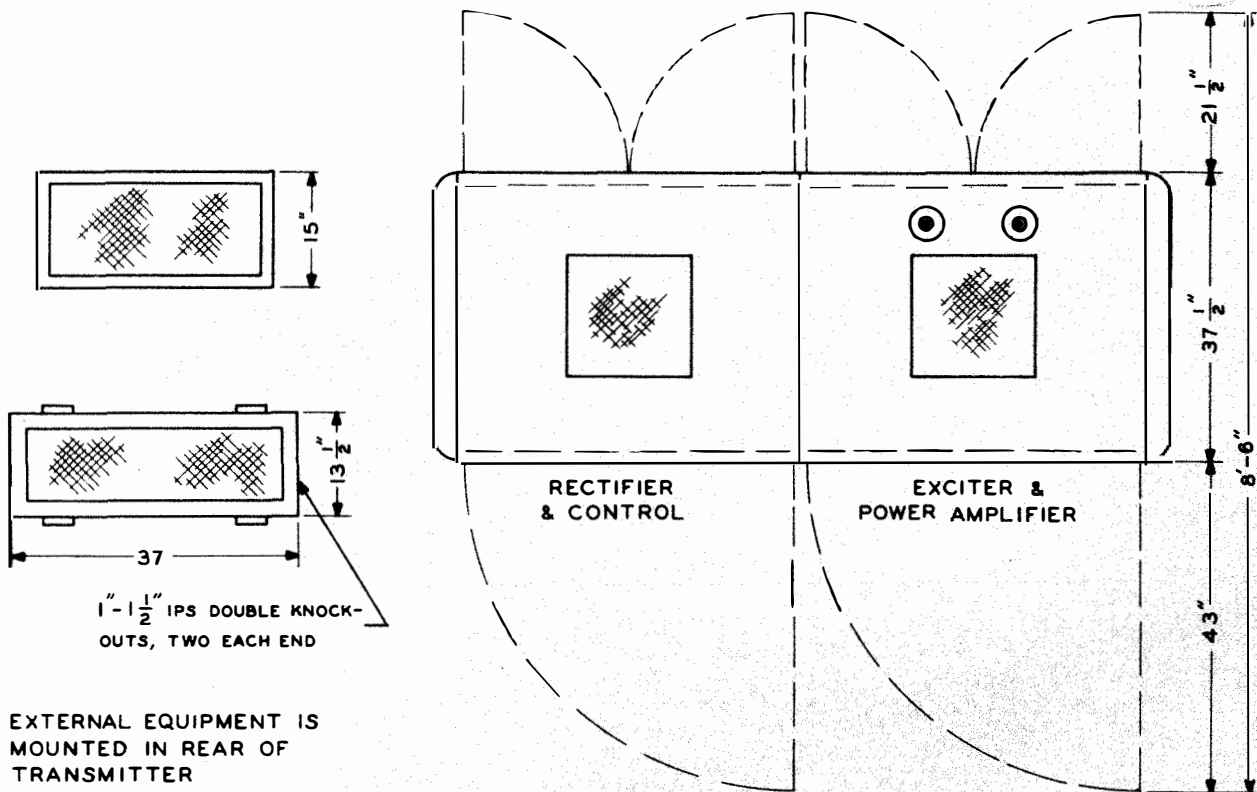

EXTERNAL EQUIPMENT IS MOUNTED IN REAR OF TRANSMITTER

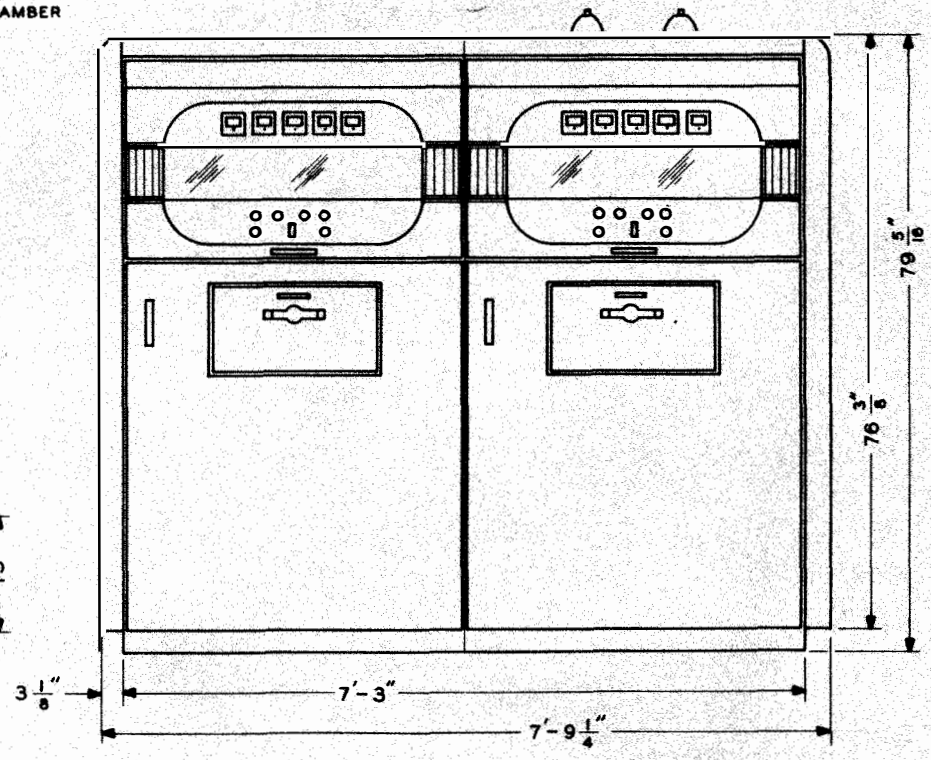
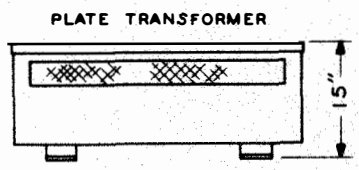
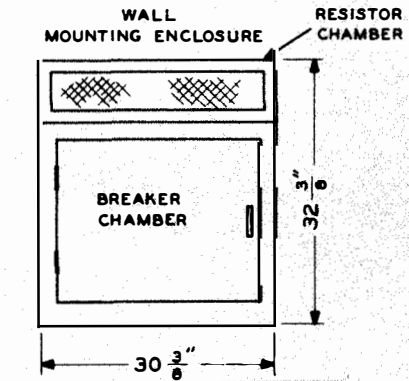

205D-1 TRANSMITTER PLAN & ELEVATION VIEWS

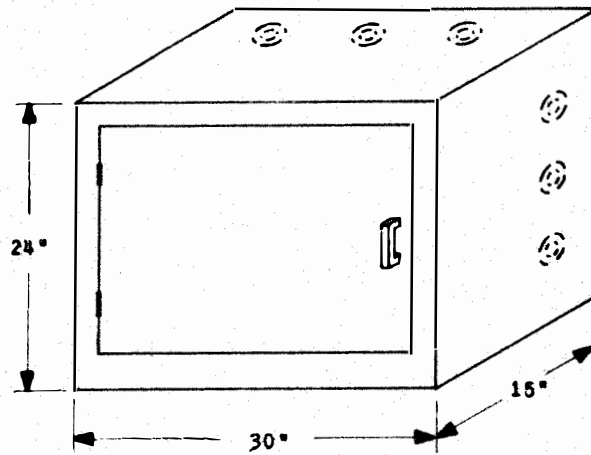

MAIN CONTACTOR - CIRCUIT BREAKER ENCLOSURE FOR EXTERNAL WALL MOUNTING

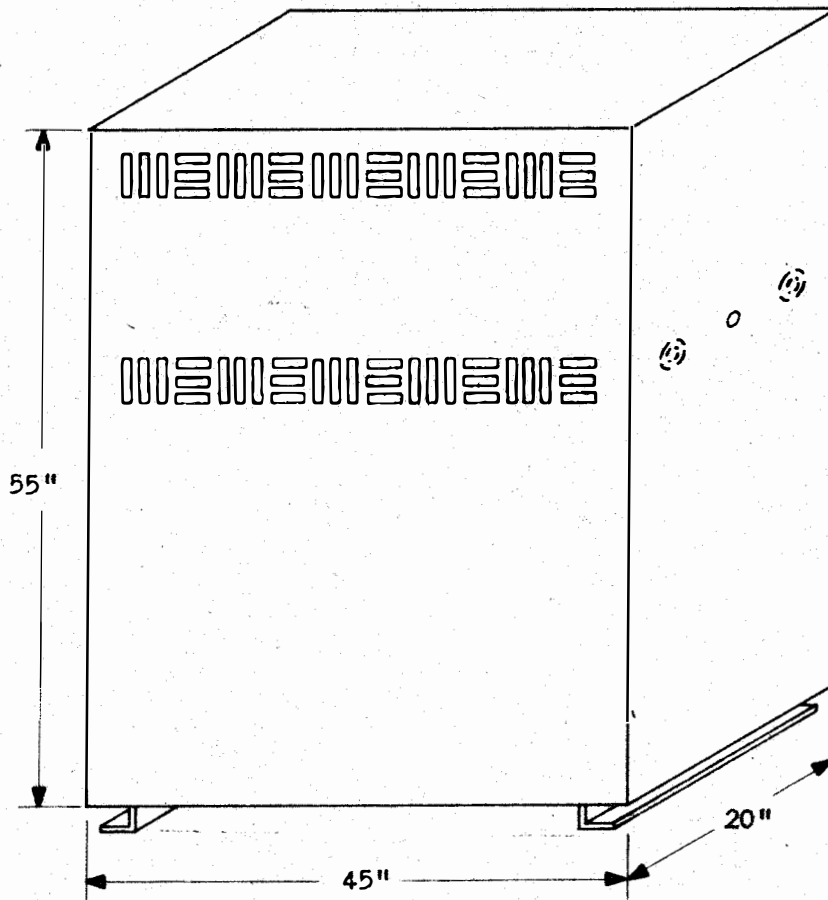

EXTERNAL PLATE TRANSFORMER - APPROXIMATE SIZE

205E EXTERNAL EQUIPMENT

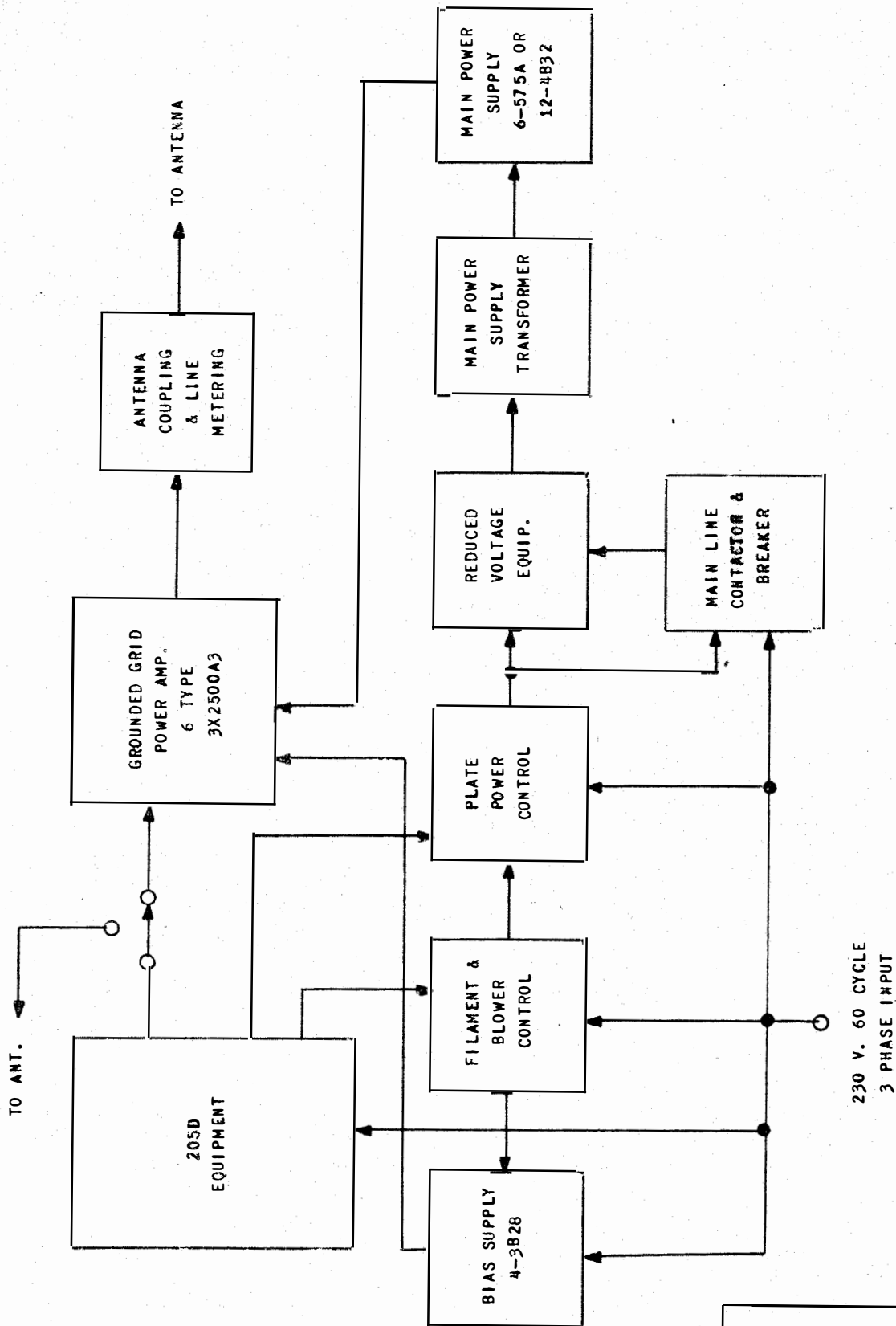

BLOCK DIAGRAM  
 COLLINS 205E-1  
 40 KW CW TRANSMITTER  
 6/18/48 J.L.H.



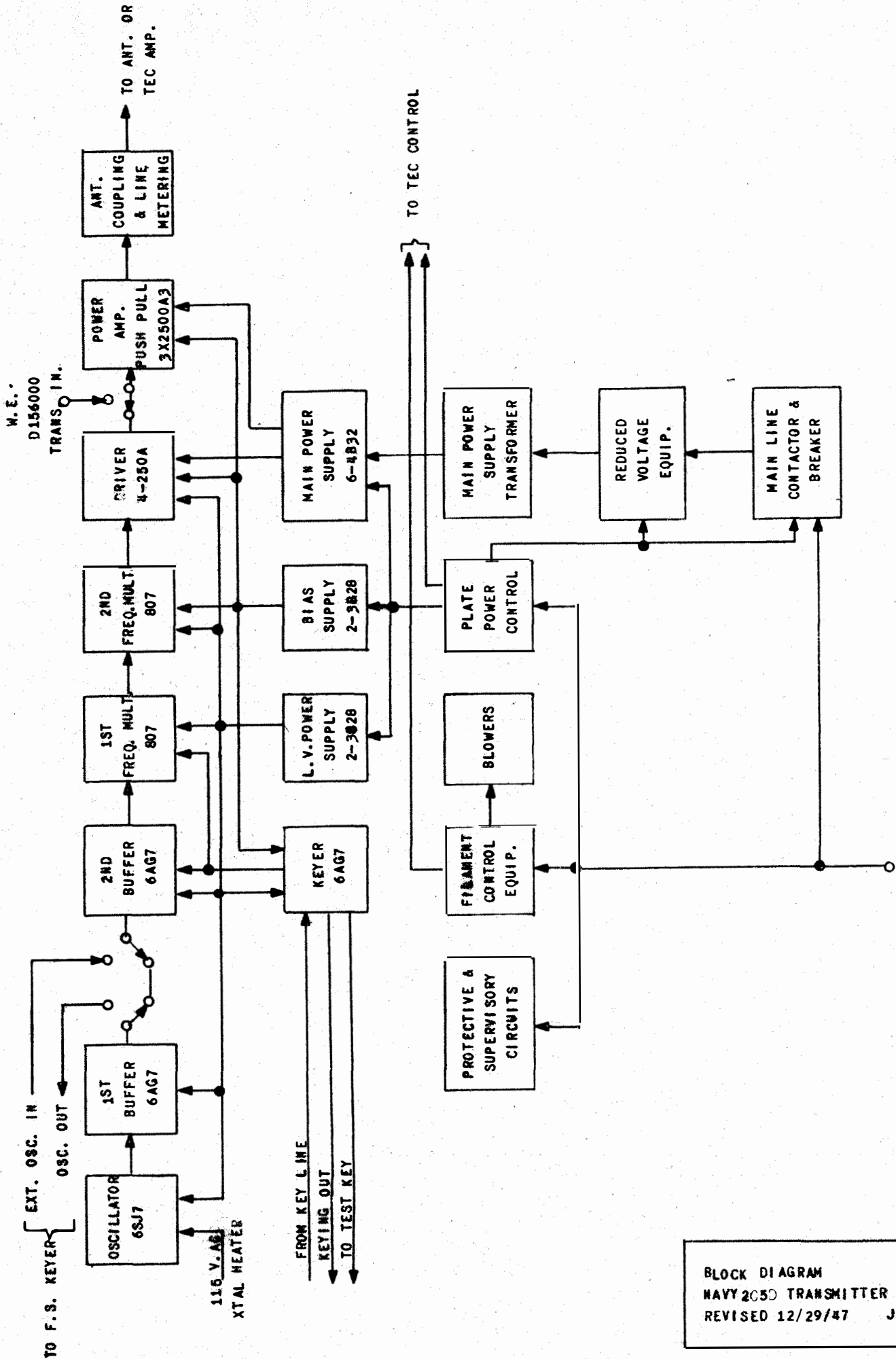

BLOCK DIAGRAM  
 NAVY 2050 TRANSMITTER  
 REVISED 12/29/47 J.L.H.

230 V. 60 CYCLE AC  
 3 PHASE INPUT