

student guide
for
**ELECTRONICS TECHNICIAN
CLASS "A" SCHOOL**

course

A-100-0062

A-100-0063

A-100-0066

**HF Transmitter/Receiver
Sub-Systems**



volume 3 (part 1)
AN/WRC-1B and
AN/URT-23(V²)

prepared by
NETPDCD
NAVAL EDUCATION & TRAINING
PROGRAM DEVELOPMENT CENTER
DETACHMENT Great Lakes

revised
January 1982



FOREWORD

This Student Guide is designed to supplement the classroom subject matter and practical application (lab exercises) of the Communications Systems section in the Electronics Technician Class "A" School Courses A-100-0062, A-100-0063, and A-100-0066.

The Student Guide, with its instructional sheets, is intended to serve as a study aid in this course of instruction and should greatly increase the student's knowledge of communications systems used in the electronics technician rate. This material may be retained by the student as a future reference and aid in the electronics field.

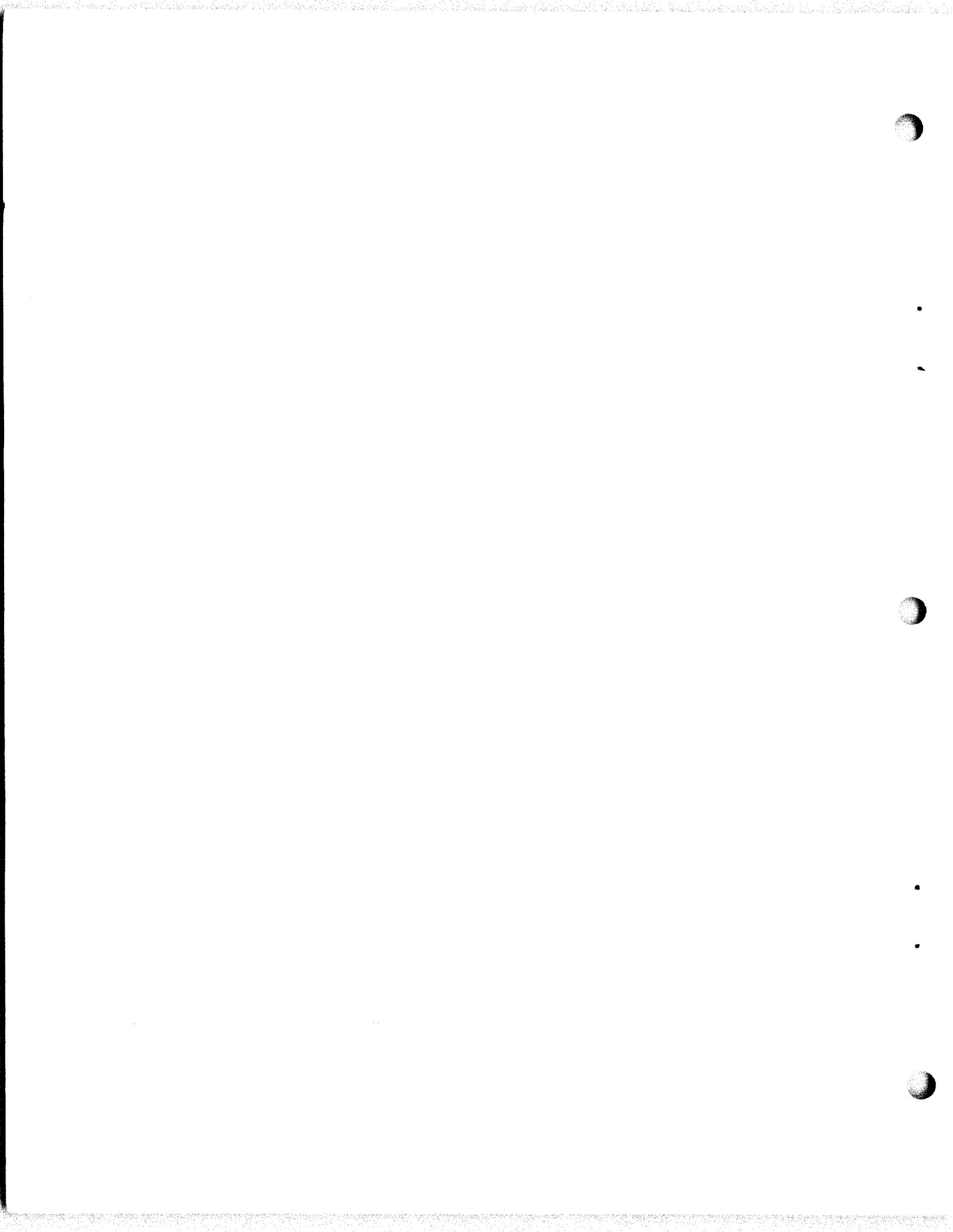
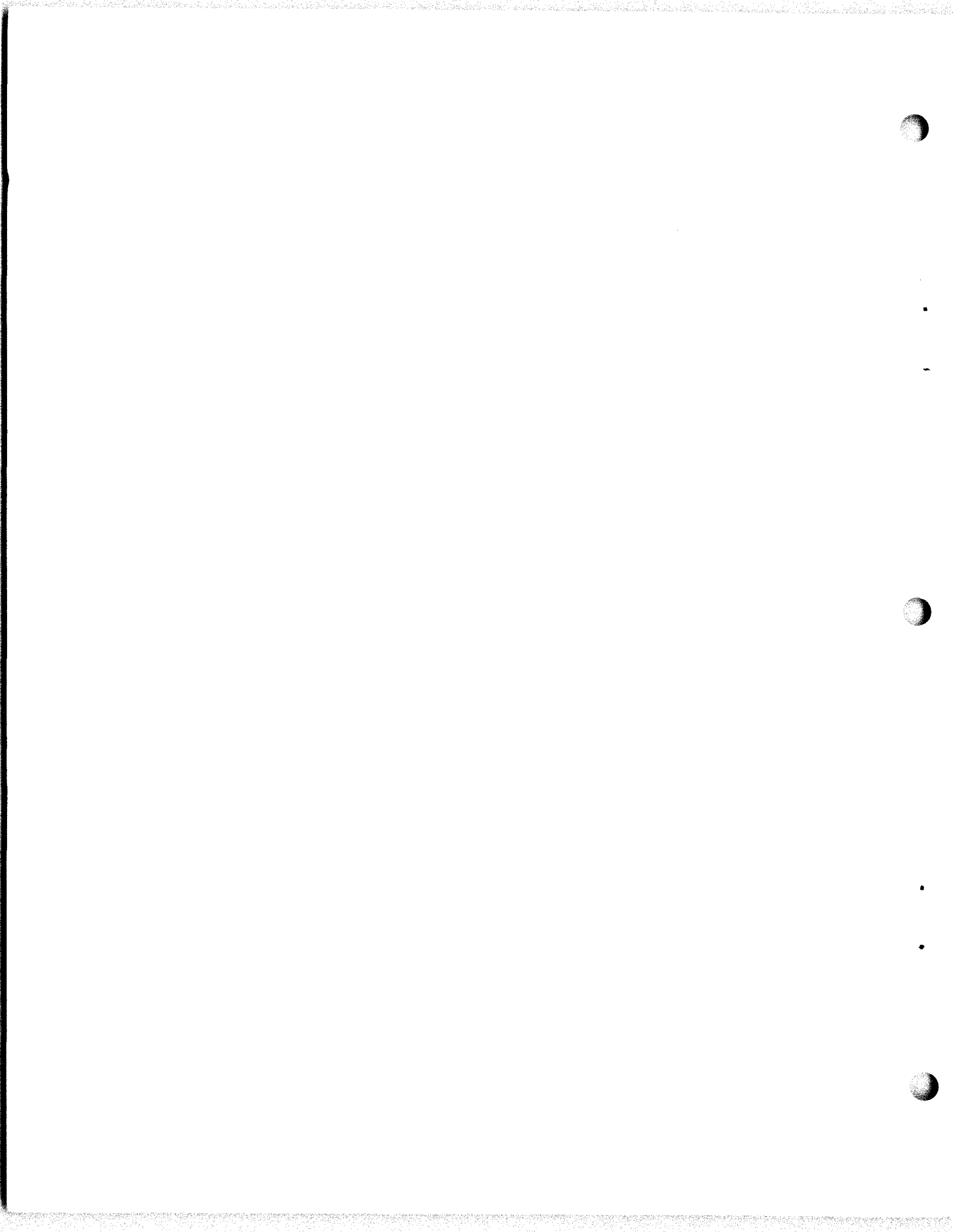

TABLE OF CONTENTS

	Page
Foreword	i
Table of Contents	iii
How To Use This Student Guide	v
Module 3.1.1.	1
Assignment Sheet 3.1.1.1 1A	2
Information Sheet 3.1.1.1.1I.	18
Information Sheet 3.1.1.1.2I	20
Job Sheet 3.1.1.1 1J.	41
Notetaking Sheet 3.1.1.1 1N	51
Assignment Sheet 3.1.1.2 1A	59
Information Sheet 3.1.1.2 1I.	65
Job Sheet 3.1.1.2 1J.	69
Notetaking Sheet 3.1.1.2 1N	74
Assignment Sheet 3.1.1.3 1A	78
Job Sheet 3.1.1.3 1J.	81
Assignment Sheet 3.1.1.4 1A	87
Assignment Sheet 3.1.1.5 1A	91
Job Sheet 3.1.1.5 1J.	95
Assignment Sheet 3.1.1.6 1A	98
Job Sheet 3.1.1.6 1J.	105
Assignment Sheet 3.1.1.7 1A	110
Assignment Sheet 3.1.1.8 1A	115
Information Sheet 3.1.1.8 1I.	121
Information Sheet 3.1.1.8 2I.	126
Job Sheet 3.1.1.8 1J.	130
Module 3.1.2.	139
Assignment Sheet 3.1.2.1 1A	140
Job Sheet 3.1.2.1 1J.	153
Assignment Sheet 3.1.2.2 1A	156
Job Sheet 3.1.2.2 1J.	159
Assignment Sheet 3.1.2.3 1A	164
Assignment Sheet 3.1.2.4 1A	167
Job Sheet 3.1.2.4 1J.	171
Assignment Sheet 3.1.2.5 1A	176
Assignment Sheet 3.1.2.6 1A	179
Job Sheet 3.1.2.6 1J.	183
Assignment Sheet 3.1.2.7 1A	186
Job Sheet 3.1.2.7 1J.	189
Module 3.1.3.	195
Assignment Sheet 3.1.3.1 1A	196
Job Sheet 3.1.3.1 1J.	197
Module 3.1.4.	203
Assignment Sheet 3.1.4.1 1A	204
Job Sheet 3.1.4.1 1J.	207
Assignment Sheet 3.1.4.2 1A	216
Job Sheet 3.1.4.2 1J.	219
Assignment Sheet 3.1.4.4 1A	224
Assignment Sheet 3.1.4.5 1A	227
Job Sheet 3.1.4.5 1J.	231
Job Sheet 3.1.4.5 2J.	239
Assignment Sheet 3.1.4.6 1A	240



HOW TO USE THIS STUDENT GUIDE

This Student Guide has been prepared for your use while attending the Electronics Technician Class "A" Course. Its primary purpose is to provide materials to enable you to gain an elementary and general knowledge of the fundamental concepts of advanced communications systems used in the electronics technician rate. You may make any notes that will help you in your review later in the course or that will help you when you are on your job at your next duty assignment.



.

.



.

.



OVERVIEW

MODULE 3.1.1

R-1051B/URR RECEIVER

In this module you will learn about the operation of the R-1051B/URR Receiver. You will learn the different types of signals that can be received and you will learn to operate the receiver. You will learn the function of each component part in the receiver, the distribution of voltages and signals in the receiver and how to check its operation. You will perform tests and adjustments and troubleshoot a faulty receiver.

The Terminal Objective of this module is:

3.2 ISOLATE a malfunction in the R-1051B/URR Receiver to the faulty component part, given technical manual, MRC, tools and test equipment. A minimum score of 70% must be achieved, based on locating the faulty component part, procedure, safety and time.

This module is divided into eight lessons:

- Lesson 3.1.1.1 Introduction to Communications and the R-1051B/URR
- Lesson 3.1.1.2 R-1051B/URR Receiver Functional Block Diagram Analysis
- Lesson 3.1.1.3 R-1051B/URR Receiver AC and DC Power Distribution Systems
- Lesson 3.1.1.4 R-1051B/URR Receiver Antenna Overload Relay and Receiver Code Generator Circuit Analysis
- Lesson 3.1.1.5 R-1051B/URR Receiver RF Amplifier Assembly Circuit Analysis
- Lesson 3.1.1.6 R-1051B/URR Receiver Frequency Standard and Translator Synthesizer Circuit Analysis
- Lesson 3.1.1.7 R-1051B/URR Receiver Mode Selector Circuit Analysis
- Lesson 3.1.1.8 R-1051B/URR Receiver IF/Audio Amplifier Assembly Circuit Analysis

ASSIGNMENT SHEET 3.1.1.1 1A

INTRODUCTION TO THE R-1051B/URR RADIO RECEIVER

INTRODUCTION:

This assignment sheet is comprised of three parts. Part I is designed to give you practice in using the Technical Manual to obtain information.

Part II is a reading assignment of the functional block analysis of the R-1051B/URR which will prepare you for the next lesson topic.

Part III consist of a reading assignment on the AC and DC power distribution in the R-1051B/URR. You will also be color coding these distribution systems on your chassis and maintenance schematics.

LESSON TOPIC OBJECTIVES:

3.1.1.1.1 Given multiple sets of specifications concerning frequency range, bandwidth, frequency accuracy and frequency stability, and the R-1051B/URR Technical manual, select the set of specifications that apply to the R-1051B/URR Receiver.

3.1.1.1.2 Verify the operation of the R-1051B/URR Receiver in accordance with Maintenance Requirement Card C-304 W-1, given the MRC, technical manual, tools, and test equipment.

3.1.1.1.3 Inspect the R-1051B/URR Receiver in accordance with Maintenance Requirement Card C-304 S-1, given the MRC, tools, and technical manual.

3.1.1.1.4 Verify the operation of the R-1051B/URR Receiver interlock system in accordance with Maintenance Requirement Card C-304 S-4, given tools and MRC.

STUDY QUESTIONS: Refer to Homework Handout

3.1.1.1 1A -H

Study Assignment Part II: R-1051B/URR Functional Block Analysis

Read and study page 3-1 (par 3-8) through page 3-10, R-1051B/URR Technical Manual Vol I.

The key points to look for in this reading assignment are:

1. Major signal path processing
2. Inputs and outputs of each function in the processing
3. Conversions accomplished and/or function of each Function

Use Functional Block diagram on page ___ of Student Guide, Volume _____ as an organizer.

3.1.1.1 1A -H

Study Assignment Part III: R-1051B/URR AC and DC Power Distribution

- A. Read and study page 3-29 (Par. 3-82) through page 3-31 R-1051B/URR Technical Manual Vol 1.
- B. Trace the power distribution of all AC and DC voltages using the chassis and mainframe schematic diagram of the R-1051B/URR in the Student Guide Volume 3. Figures 1 thru 8 will aid in locating the circuits on the schematic diagram. All power is derived from the 115 VAC line connected to 1A1J3 on the rear of the case. The power supply consists of the +110 VDC, +28 VDC, -30 VDC, regulated +20 VDC, 6.3 VAC and +4 VDC power supplies.

1. Using a black and red pencil or fine point felt tip pen and Figure 1 color code the 115 VAC input to the R-1051B.
2. Next to pins R and S on the chassis and mainframe schematic are pins A and C, labeled auxiliary 115 VAC supply. This added connection, along with the AUX/NORM switch, 1A2S7, allow the R-1051B to be operated as a separate receiver with S7 in the norm position. The R-1051B is being used in a configuration such as the WRC-1B and power is being supplied from a central junction box to the receiver via pins R and S. With S7 in the auxiliary position, the input power is supplied through pins A and C, from a separate power cord. The R-1051B is now being used as a separate receiver.

Two fuses are being used in the R-1051B because in fleet installations 60 VAC is supplied to each side of the input with a common ground to them.

- a. What is the purpose of DS1 and DS2?
- b. What is the purpose of the multiple taps on primary of 1A2T1?
3. Using a YELLOW pencil or fine point felt tip pen and the Figure 2, color code the mainframe 6.3 VAC distribution using dashed lines.
 - a. What is the 6.3 VAC supply used for? _____
 - b. What would the symptoms be if 6.3 VAC was lost? _____
4. Using a blue pencil or fine point felt tip pen and Figure 3, color code the mainframe +110 VDC supply distribution.

NOTE: The +110 VDC at K3, pin 8 is RECEIVE +110 V. Use DASHED blue lines to code this line.

- a. In what position must S6 be for DS5 to be lit? _____
- b. How can DS5 be used as a troubleshooting aid when checking the +110 VDC power supply? _____

3.1.1.1 1A-H

5. Using a GREEN pencil or fine point felt tip pen and Figure 4, color code the mainframe +28 VDC supply distribution.

NOTE: The +28 VDC at K1, pin 6 is called INTERLOCKED +28 V. Use DASHED green lines to code this line.

6. Using a ORANGE pencil or fine point felt tip pen and Figure 5, color code and mainframe -30 VDC power supply distribution.
- a. How are the -30 VDC inputs to the IF/AF Amplifier Assemblies used? _____

7. Using a PURPLE pencil or fine point felt tip pen and Figure 7, color code the RECEIVE +20 VDC supply.

NOTE: After entering the MODE SELECTOR switch (Section A, Rear), the +20 VDC is only present at pins 11, 2, and 5 when the appropriate modes are selected. Use PURPLE dots on these three lines.

- a. Which front panel control regulates the distribution of +20 VDC to the A12A1, 1A2A2, and 1A2A3 subassemblies? _____
8. Using a PURPLE pencil or fine point felt tip pen and Figure 7, color code the Receive +20 VDC supply.

NOTE: Dotted lines indicate lines controlled by position of MODE SELECT switch.

- a. What position of the MODE SELECT switch will supply +20 VDC to the BFO FREQ Control? _____
9. Using a BROWN pencil or fine point felt tip pen and Figure 8, color code the +4 VDC 100 cps supply.

NOTE: The +4 VDC is fed by the +20 VDC regulated (orange) supply. Use "dots" to code the +4 VDC line.

- a. What is the function of 1A2A11CR1 in the +4 VDC supply? _____

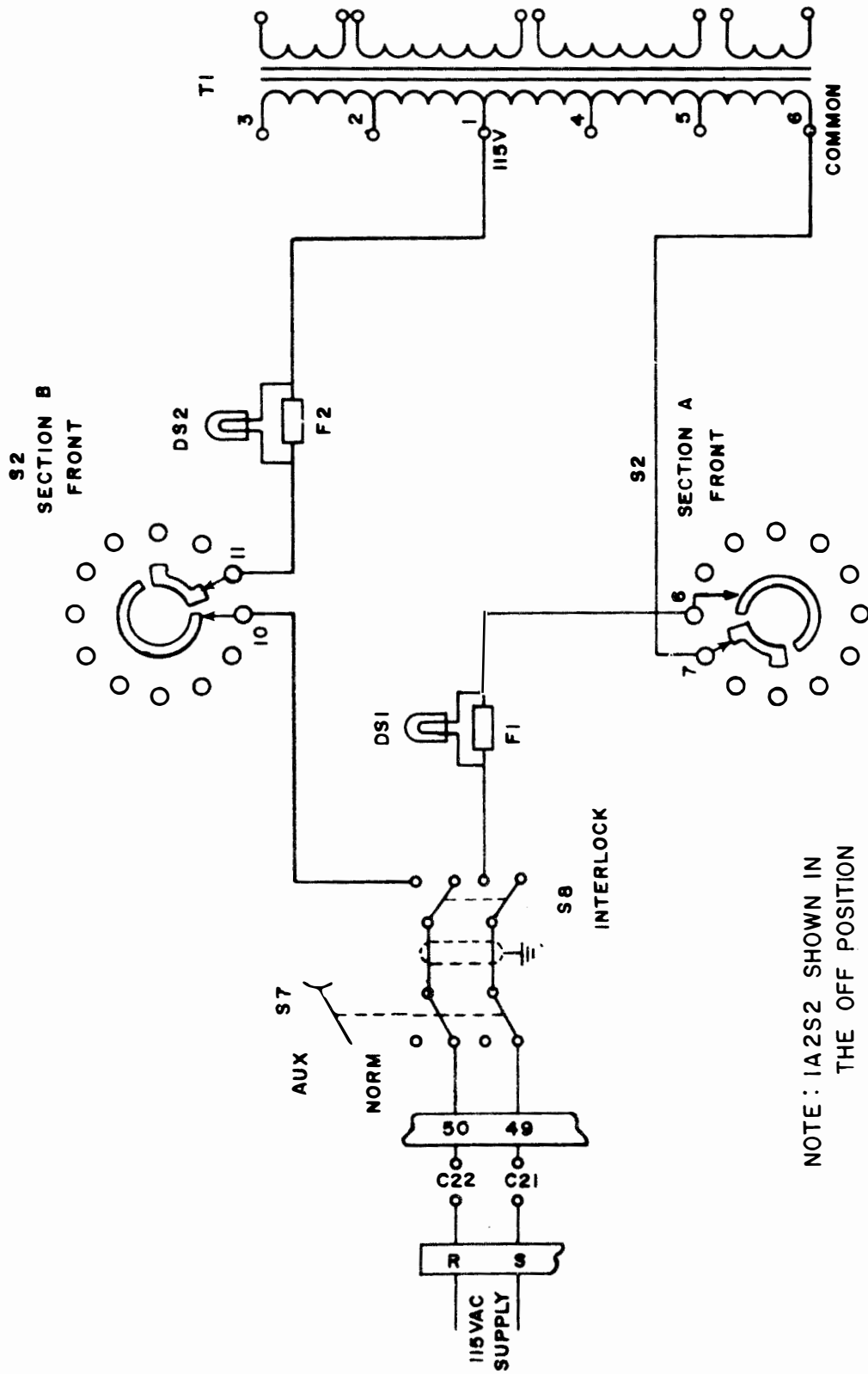

FIGURE 1

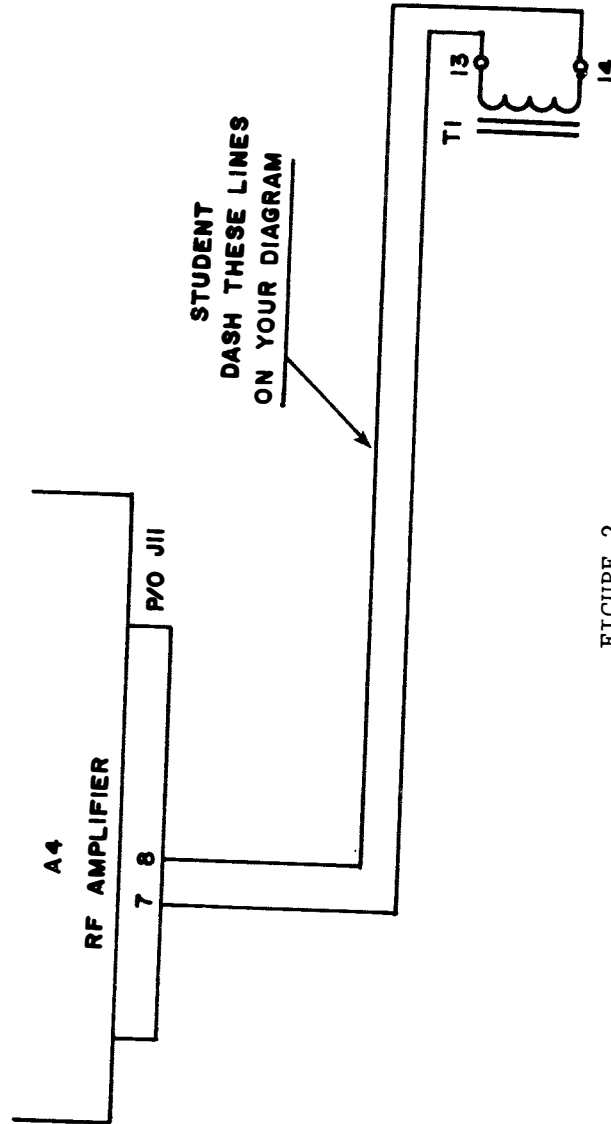

FIGURE 2

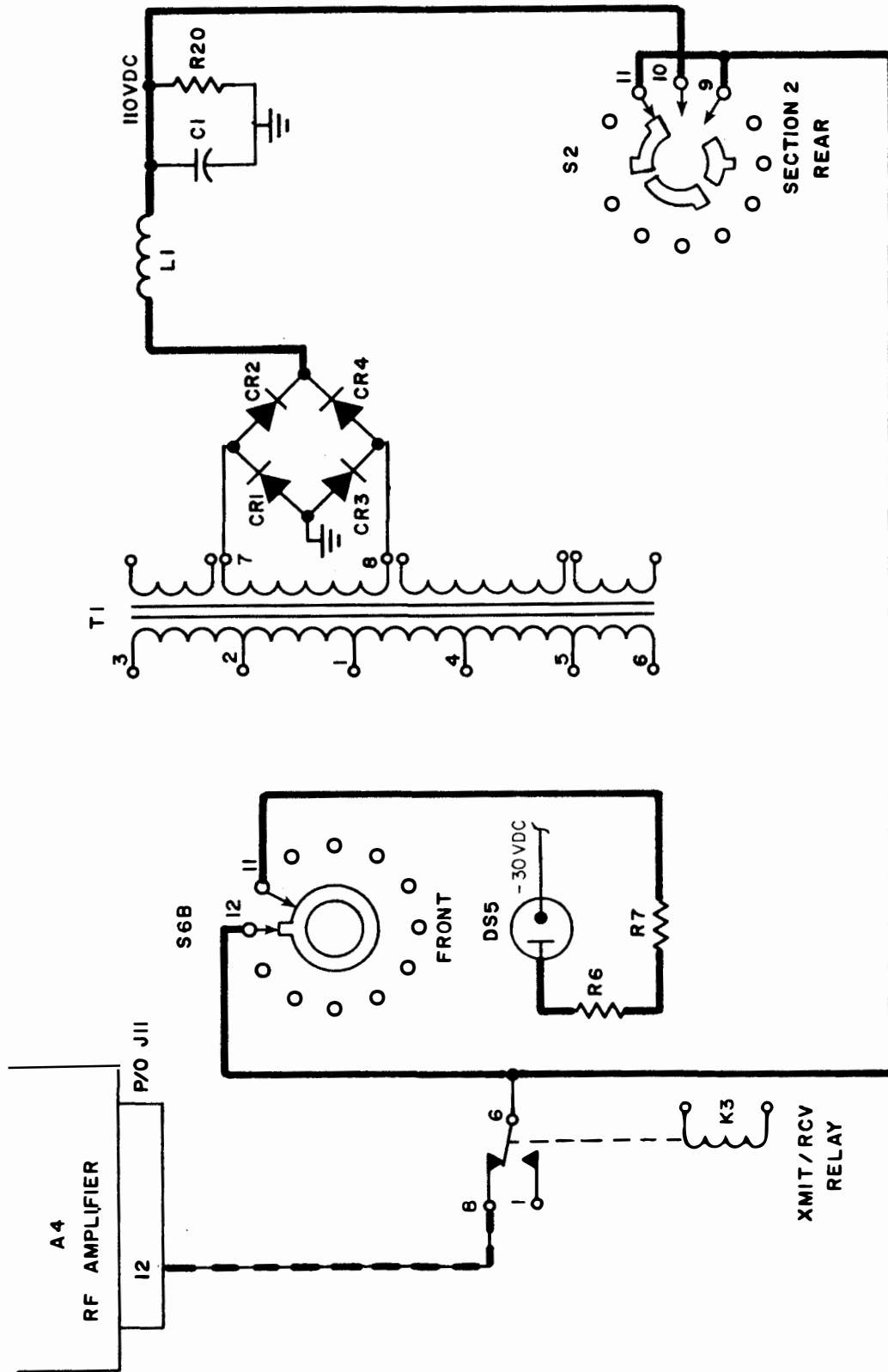

FIGURE 3

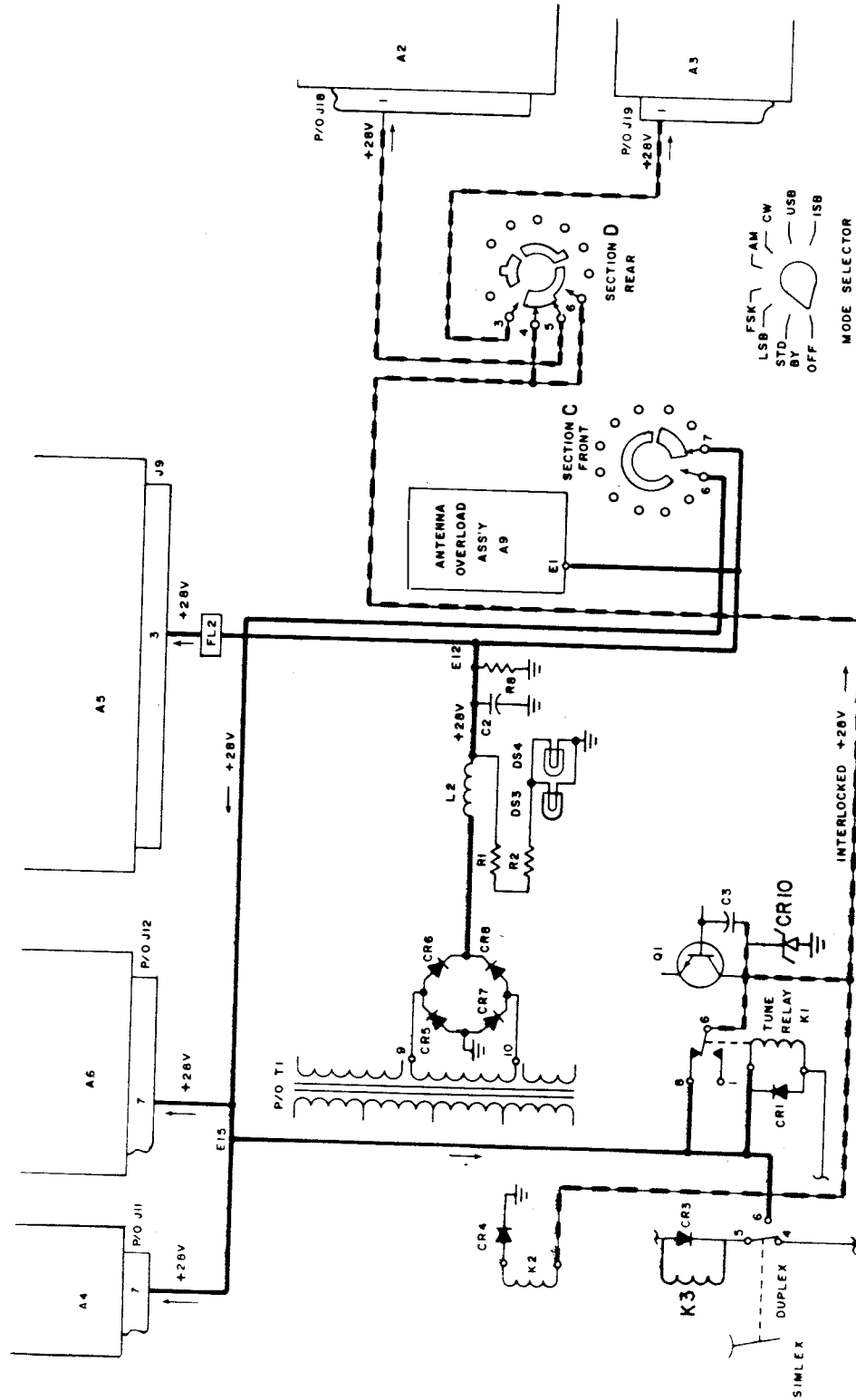

FIGURE 4

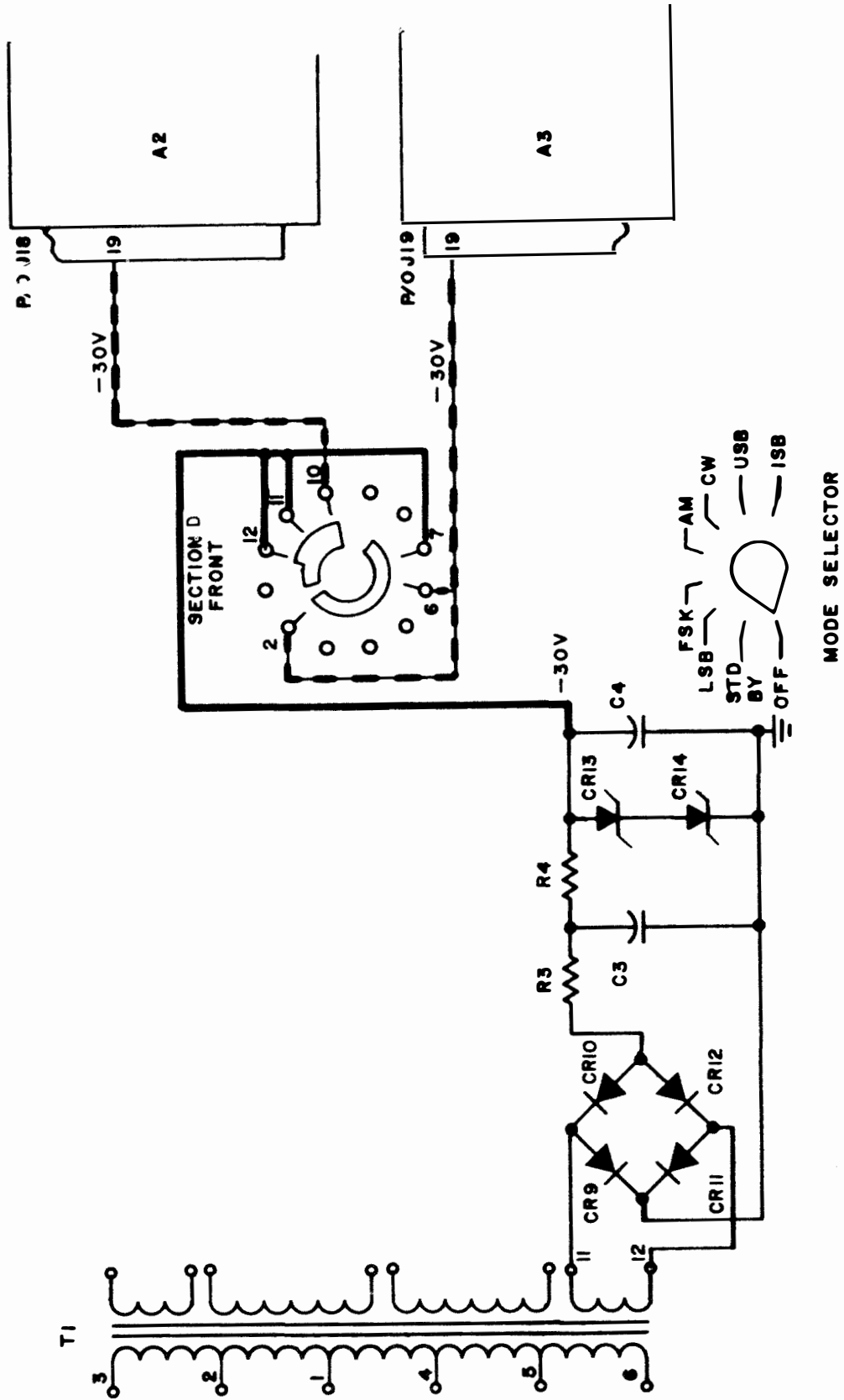

FIGURE 5

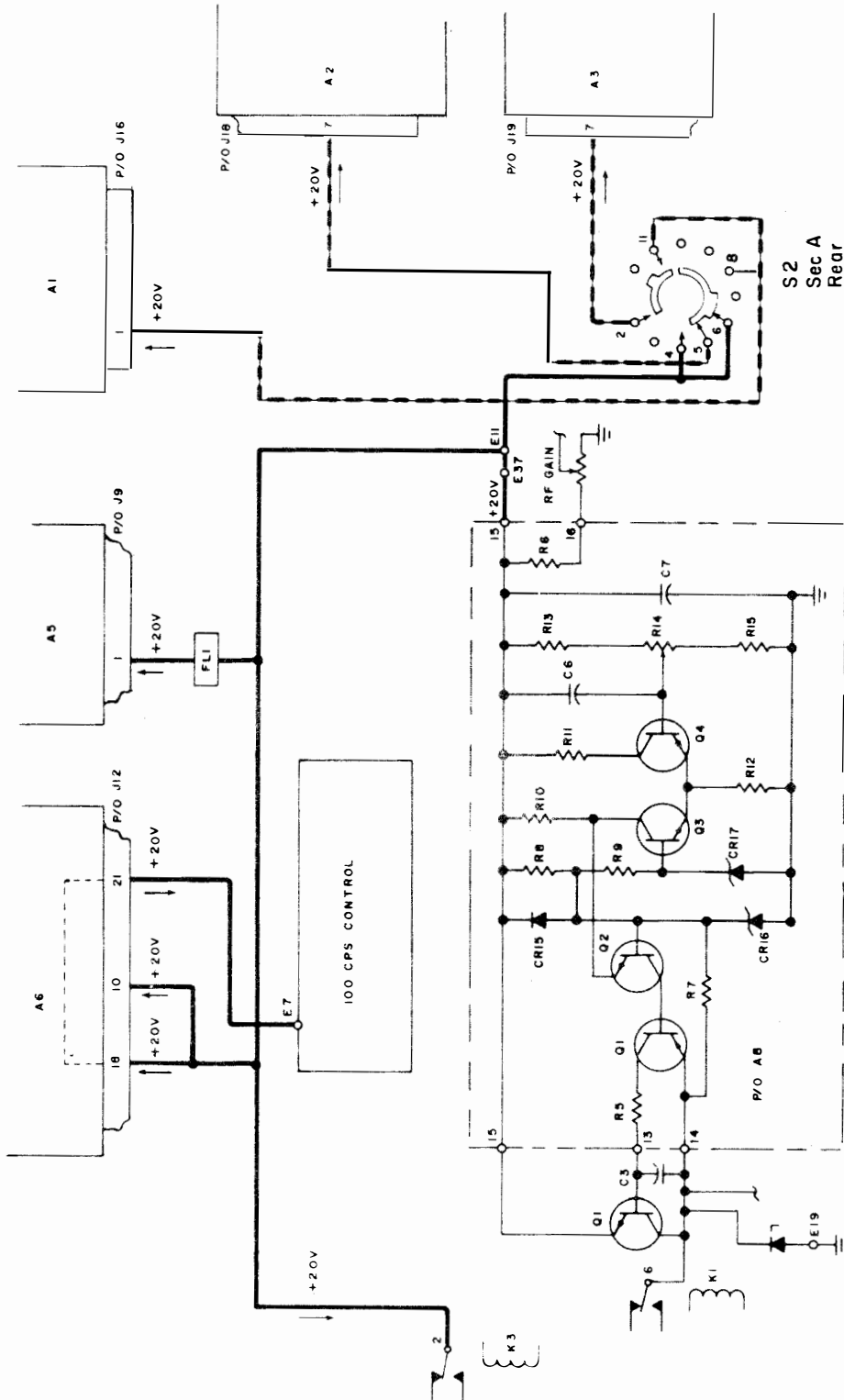

FIGURE 6

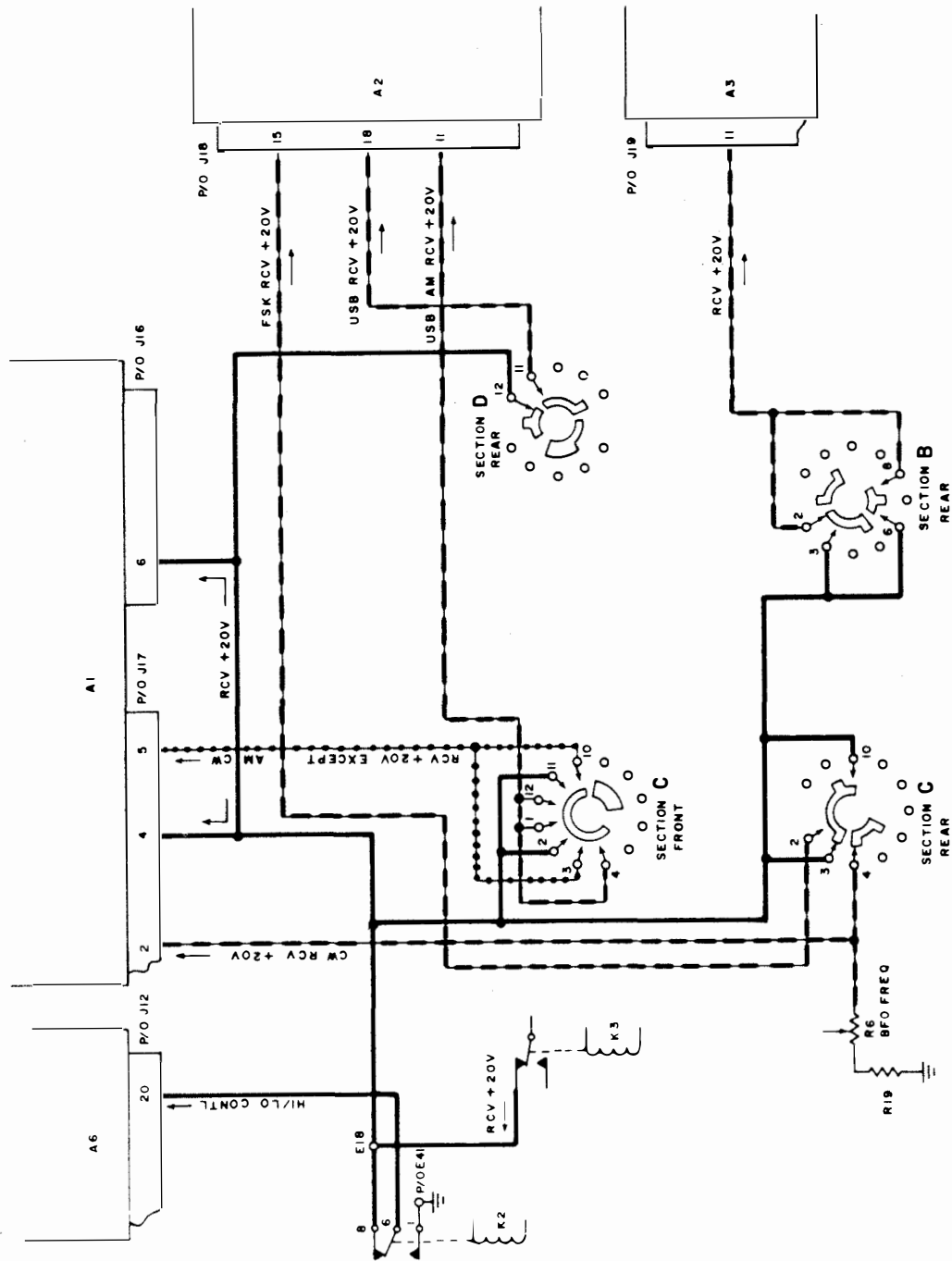

FIGURE 7

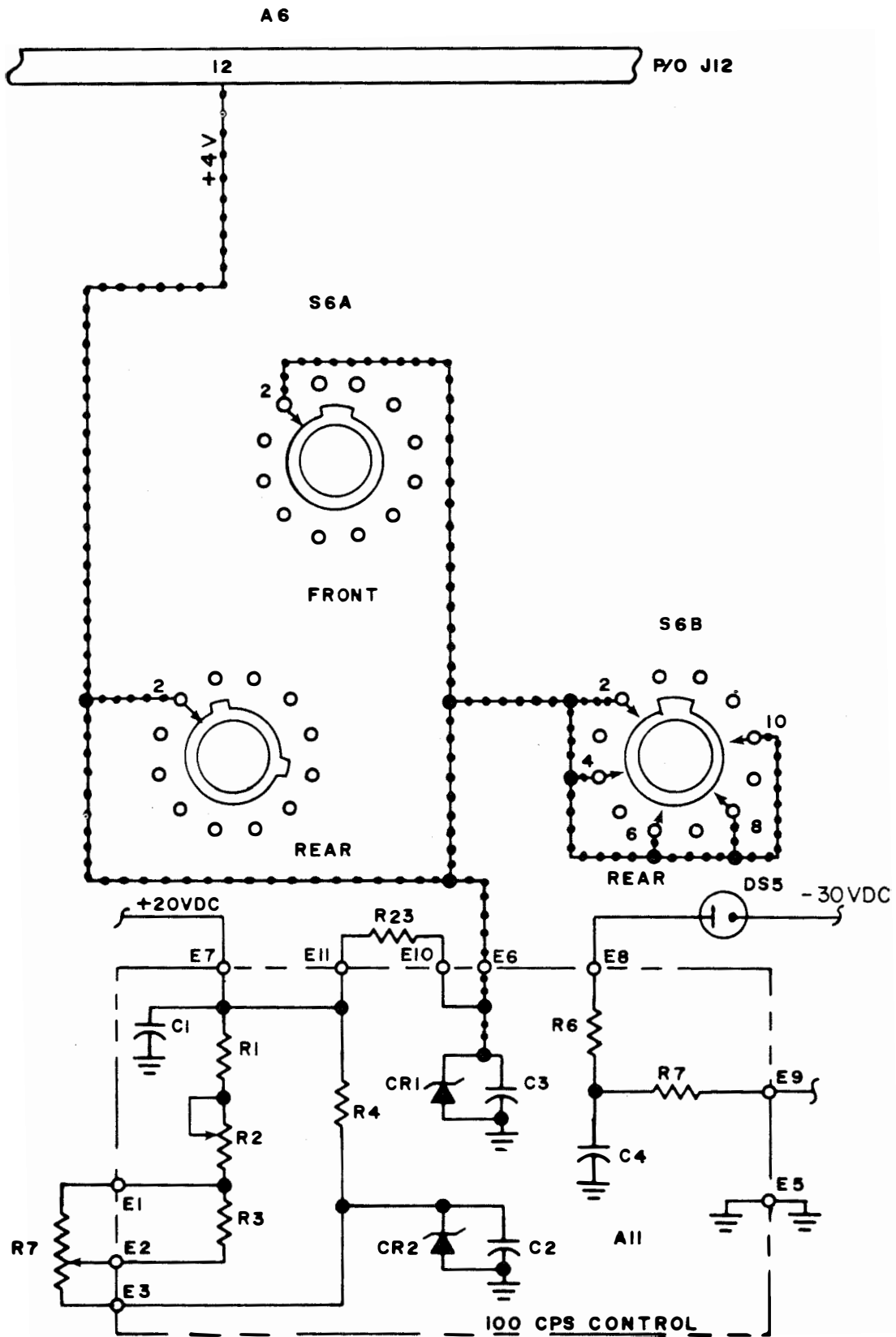
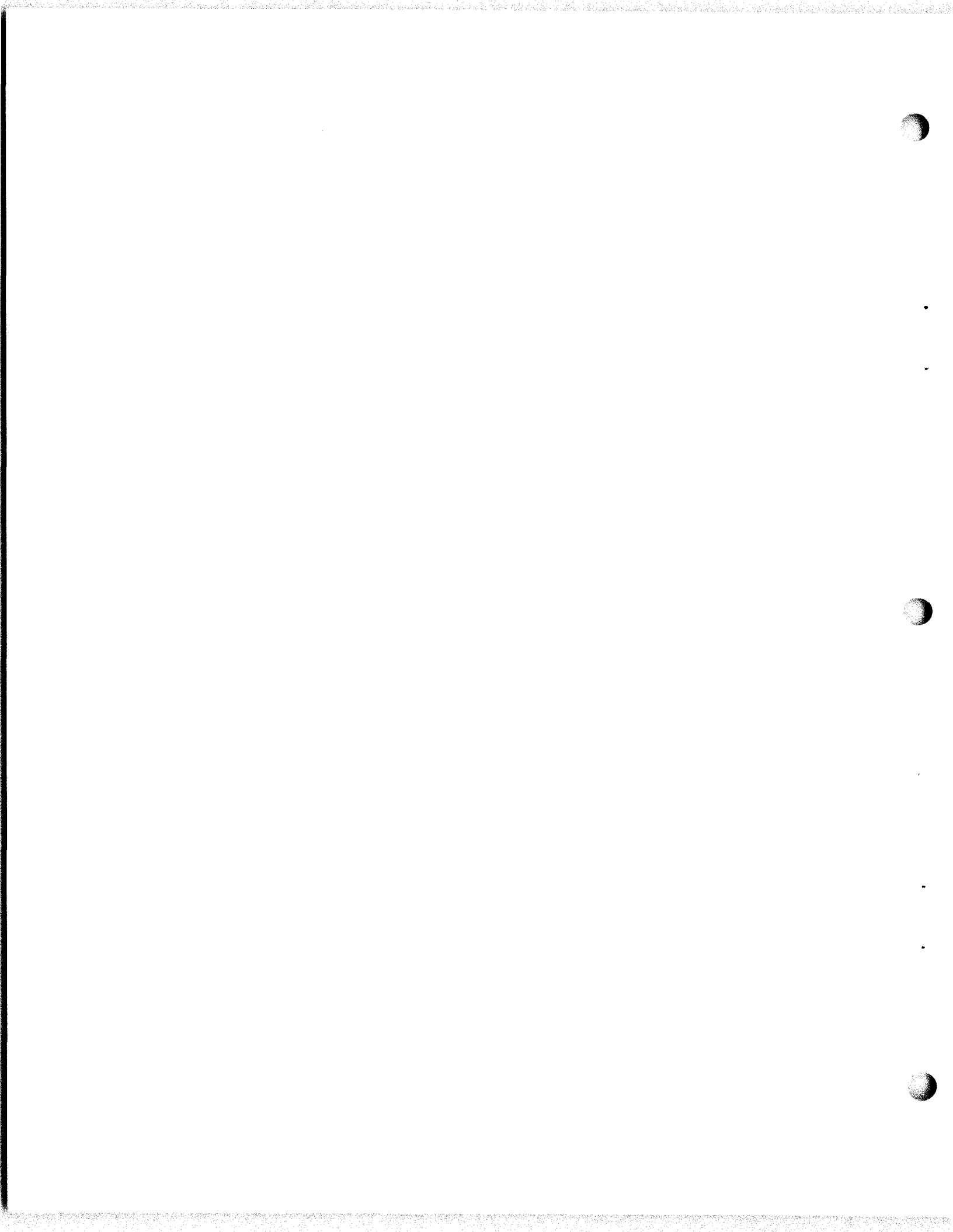

FIGURE 8



THIS PAGE LEFT BLANK INTENTIONALLY

STANDARD FREQUENCIES AND TIME SIGNALS

INTRODUCTION

Accuracy of frequencies is of prime importance in today's communications. Frequency standards are employed to ensure these accuracies. One standard that is available to all is furnished by The National Bureau of Standards via radio propagation. They are convenient signals for many applications. This information sheet will introduce you to their services.

REFERENCES

The Radio Amateur's Handbook, published by the American Radio Relay League, Newington, Conn. 06111, 56th edition, 1979

INFORMATION

The National Bureau of Standards maintains two radio transmitting stations, WWV at Ft. Collins, Colorado and WWVH near Kekaha, Kauai, Hawaii for broadcasting standard radio frequencies of high accuracy. WWV and WWVH broadcast are on 2.5, 5, 10 and 15 MHz. The broadcasts of both stations are continuous, night and day. Standard audio frequencies of 440, 500 and 600 Hz are broadcast on each radio-carrier frequency by WWV and WWVH. The duration of each tone is approximately 45 seconds. A 500 Hz tone is broadcast during even alternate minutes unless voice announcements or silent periods are scheduled. A 440 Hz tone is broadcast beginning one minute after the hour by WWVH and two minutes after the hour by WWV. The 440 Hz tone period is omitted during the first hour of the UTC day.

Transmitted frequencies from the two stations are accurate to ± 1 part in 10. Atomic frequency standards are used to maintain this accuracy. Voice announcements of the time, in English, are given every minute. WWV utilizes a male voice, and WWVH features a female voice to distinguish between the two stations. WWV time and frequency broadcasts can be heard by telephone also. The number to call is 303-499-7111, Boulder, Colorado.

All official announcements are made by voice. Time announcements are in UTC (Universal Coordinated Time). One-second markers are transmitted throughout all programs except that the 29th and 59th markers of each minute are omitted. Detailed information on hourly broadcast schedule is given in the accompanying format chart. Complete information on the services can be found in NBS Special Publication 432, NBS Frequency and Time Dissemination Services, available for 60 cents from the Superintendent of Documents, U.S. Government Printing Office, Washington, DC 20402.

Geophysical Alerts "Geoalerts" are broadcast in voice during the 18th minute for each hour from WWV. The messages are changed each day at 0400 UT with provisions to schedule immediate alerts of outstanding occurring events. Geoalerts tell of geophysical events affecting radio propagation, stratospheric warming, and related events.

3.1.1.1 II

WWV BROADCAST FORMAT

VIA TELEPHONE (303) 499-7111
(NOT A TOLL-FREE NUMBER)

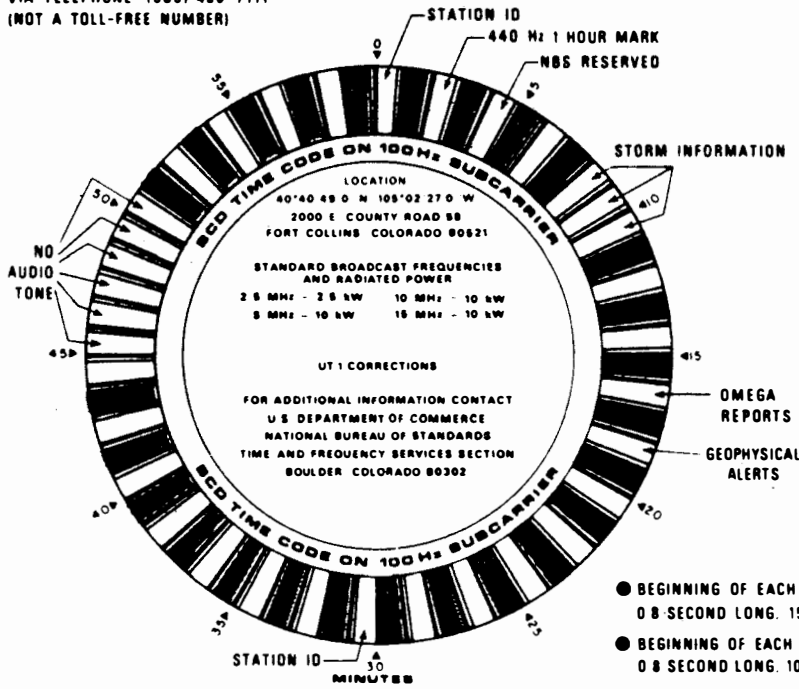

U.S. DEPARTMENT OF COMMERCE
National Bureau of Standards

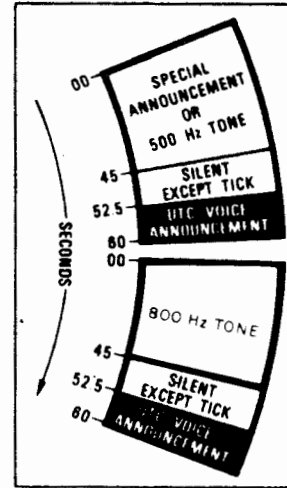

- BEGINNING OF EACH HOUR IS IDENTIFIED BY 0.8 SECOND LONG, 1500 Hz TONE
- BEGINNING OF EACH MINUTE IS IDENTIFIED BY 0.8 SECOND LONG, 1000 Hz TONE
- THE 29th & 59th SECOND PULSE OF EACH MINUTE IS OMITTED

WWVH BROADCAST FORMAT

VIA TELEPHONE (808) 335-4363 (NOT A TOLL-FREE NUMBER)

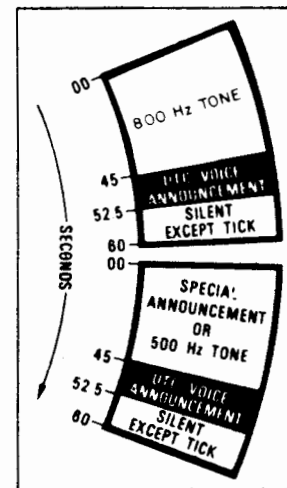
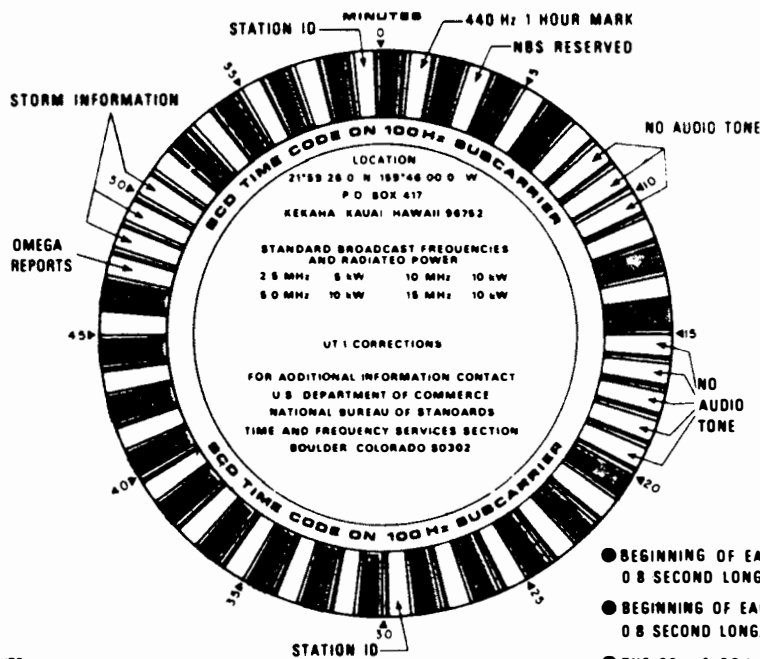

- BEGINNING OF EACH HOUR IS IDENTIFIED BY 0.8 SECOND LONG, 1500-Hz TONE
- BEGINNING OF EACH MINUTE IS IDENTIFIED BY 0.8 SECOND LONG, 1200-Hz TONE
- THE 29th & 59th SECOND PULSE OF EACH MINUTE IS OMITTED

DOCUMENTING A COMPLETED MAINTENANCE ACTION

INTRODUCTION

This information sheet will provide you with a basic introduction to complete Maintenance Action Documentation as required by the Maintenance Data Collection Sub-system (MDCS). MDCS is a part of the Navy Maintenance and Material Management Program (3-M). This Information Sheet contains illustrated, easy to follow instructions on how to complete the OPNAV 4790/2K (Ships Maintenance Action Form) for a completed maintenance action normally performed in a work center aboard ship.

Most of the code listings necessary for various blocks of the "2K" form are included as appendixes. The other manuals and publications mentioned are available in the work center or supply department.

REFERENCE(S)

OPNAVINST 4790.4, Volume II, 3M Manual

INFORMATION

In accordance with OPNAVINST 4790.4, Volume II, completed maintenance action documents will be submitted by surface ships ONLY in the following cases:

- a. When a maintenance action is material history significant.
- b. All corrective maintenance on selected equipment.
- c. Whenever a configuration change occurs to installed equipment or systems.

Submarines will report all corrective maintenance in accordance with OPNAVINST 4790.4, Volume II.

The following pages contain general information and illustrations of required entries for a Completed Maintenance Action with instructions for completing each block of the form.

3.1.1.1 2I

General information:

Section 1 of the Maintenance Data Form is used to identify the reporting activity and the equipment or system on which maintenance actions are being performed. Blocks A, B, 1 through 9, 13, 14, 16 and 17 are always filled in when reporting a maintenance action. Block 15 shall be marked (X) when a safety hazard threatens personnel. Blocks 19 through 24 are used for the numbers assigned by the INSURV Board. Blocks 10, 11, and 12 are not used. All entries must be legible and should be inserted within the 'tic' marks. To avoid error, care must be taken with the following characters:

- 1/I Make a 1 (one) without a flag and an "I" with flags at top and bottom.
- E/F Make sure the bottom of the "E" does not disappear in a line on the form, making it look like an "F".
- T/I Make sure the bottom on the "I" does not disappear into the line on the form, making it look like a "T".
- 2/Z Put a slash through the "Z" (Z).
- 6/G Make sure the loop in the "6" is closed, and that the flag on the vertical line of the "G" is distinct.
- 5/S Make sure the top of a five is square and put flags on the ends of "S".
- U/V Make the bottom of the "U" curved and put a tail on it. Make the "V" with a distinct point at the bottom.
- Ø/O Put a slash through the numeric zero and leave the alphabetic "O" open.

3.1.1.1 2I

OPNAV 4790/2K (Rev. 6-73) SHIP'S MAINTENANCE ACTION FORM (2-KILO) COMP DEFL

SECTION I. IDENTIFICATION		JOB CONTROL NUMBER																			
1. SHIP'S UIC 521760E010001		2. WORK CENTER		3. JOB SEQ. NO.		4. APL/AEL															
A. SHIP'S NAME				B. EQUIPMENT ROOM NAME				6. W W D		7. S S T A		8. C C A S		9. D D F R		10.		11. 12.			
10. HULL NUMBER				13. IDENT./EQUIPMENT SERIAL NUMBER				14. EIC													
19. SAFETY HAZARD <input type="checkbox"/>		16. LOCATION (Compartment/Deck/Frame/Side)						17. WHEN DISCOVERED DATE YR DAY													
CONFIGURATION CHANGE										FOR INSURY USE											
18. ALTERATIONS (REPAIR, GRIND, P12 Chg., etc.)										19. ***		20. INSURY NUMBER		21. SUFFIX		22. V		23. S		24. P/F	

BLOCK 1 - SHIP'S UIC
(SHIP'S UNIT IDENTIFICATION CODE)

Will always remain the same for any given ship. Unit Identification Code was formerly called "ship's accounting number."

BLOCK 2 - WORK CENTER

Will always remain the same for any work center.

BLOCK 3 - JOB SEQ. NO.
(JOB SEQUENCE NUMBER)

A four digit number used to identify the specific maintenance action being reported. Every work center will use sequential numbers starting with 0001 as assigned by the work center supervisor.

NOTE (1): All information for blocks 1, 2 and 3 should be obtained from the work center supervisor.

NOTE (2) Blocks 1, 2, and 3 as a group, make up the (JCN) JOB CONTROL NUMBER. The JCN is the number that identifies all maintenance and supply documents concerning any one maintenance action.

COMP/DEFL

Appropriate block must always be marked to denote the type of maintenance action. Enter "X" in COMP block for completed action.

OPNAV 4790/2K (Rev. 6-73)		SHIP'S MAINTENANCE ACTION FORM (2-KILO)				COMP	DEFL
SECTION I. IDENTIFICATION		JOB CONTROL NUMBER		4. APL/AEL			
1. SHIP'S UIC		2. WORK CENTER		3. JOB SEQ. NO.		58981766	
A. SHIP'S NAME		E. EQUIPMENT NOUN NAME		6. W N D		7. S T A	
USS ROGERS		AN/SPS-10F		8. C A S		9. D P R	
B. HULL NUMBER		13. IDENT./EQUIPMENT SERIAL NUMBER		14. ETC		10. 11. 12.	
DD-876							
15. SAFETY HAZARD <input type="checkbox"/>		16. LOCATION (Compartment/Deck/Floor/Side)		17. WHEN DISCOVERED DATE		YR DAY	
18. ALTERATIONS (REPAIR, ORDAIT, Pld Chg, etc.)		CONFIGURATION CHANGE		FOR INSURY USE			

BLOCK A - SHIP'S NAME

Ship's name must be entered in this space for all maintenance actions.

BLOCK B - HULL NUMBER

Ship's hull number must be entered in this space for all maintenance actions.

BLOCK 4 - APL/AEL
(ALLOWANCE PARTS LIST/ALLOWANCE EQUIPAGE LISTING)

Enter the APL or AEL number for the component or part being worked on. If none exists use the APL/AEL of the next higher level equipment. This number is found in the Coordinated Shipboard Allowance List (COSAL) (kept in the supply office of your Department office), or in the List of Effective Pages (LOEP) of the PMS Record. If after thorough research, it is determined that the APL/AEL is not listed in the COSAL or LOEP, enter "NOT LISTED." For non-maintenance items, enter "NA".

BLOCK 5 - EQUIPMENT NOUN NAME

Enter the noun name of the equipment on which maintenance is being reported. The noun name is limited to 16 positions; use standard abbreviations, if necessary, while retaining clarity. For those electronic equipments having an AN (Army-Navy) designation, it will be substituted for the noun-name of the equipment.

3.1.1.1 2I

OPNAV 4790/2K (Rev. 6-73)		SHIP'S MAINTENANCE ACTION FORM (2-K1LO)				COMP	DEFL														
SECTION I. IDENTIFICATION		JOB CONTROL NUMBER																			
1. SHIP'S UIC		2. WORK CENTER		3. JOB SEQ. NO.		4. APL/AEL															
A. SHIP'S NAME		B. EQUIPMENT MAIN NAME				<table border="1"> <tr> <td>6. WND</td> <td>7. STA</td> <td>8. CAS</td> <td>9. DFR</td> <td>10.</td> <td>11.</td> <td>12.</td> </tr> <tr> <td colspan="7" style="text-align: center;">2216</td> </tr> </table>		6. WND	7. STA	8. CAS	9. DFR	10.	11.	12.	2216						
6. WND	7. STA	8. CAS	9. DFR	10.	11.	12.															
2216																					
B. HULL NUMBER		13. IDENT./EQUIPMENT SERIAL NUMBER		14. ETC																	
15. SAFETY HAZARD <input type="checkbox"/>	16. LOCATION (Compartment/Deck/Frame/Side)				17. WHEN DISCOVERED DATE																
CONFIGURATION CHANGE				FOR INSURRY USE																	
18. ALTERATIONS (SW/PALT, ORDAIT, Pld Chg, etc.)				19. A/P/P	20. INQUIRY NUMBER	21. SUPPL	22. VNS/S														
						23. P/F															

BLOCK 6 - WND
(WHEN DISCOVERED)

Enter the code that identifies when the need for maintenance was discovered. A single number code obtained from Appendix 2.

BLOCK 7 - STA
(STATUS)

Enter the code which most accurately describes the effect of the failure or malfunction on the operational performance of the equipment or system when the need for maintenance was first discovered. A single number code obtained from Appendix 3.

BLOCK 8 - CAS
(CAUSE)

Enter the code that describes in the maintenance man's opinion, the cause of the failure or malfunction when the need for maintenance was first discovered. A single number code obtained from Appendix 4.

BLOCK 9 - DFR
(DEFERRAL REASON)

Enter the Deferral Reason Code which best describes why maintenance cannot be done at the time of deferral. "0" is used on all completed actions not previously deferred. A single number code obtained from Appendix 5.

3.1.1.1 2I

OPNAV 4790/2K (Rev. 6-73)		SHIP'S MAINTENANCE ACTION FORM (2-KILO)				COMP	DEFL					
SECTION 1. IDENTIFICATION		JOB CONTROL NUMBER										
1. SHIP'S UIC	2. WORK CENTER	3. JOB SEQ. NO.	4. APL/AEL									
A. SHIP'S NAME		5. EQUIPMENT HOUR NAME				6. W N D	7. S T A	8. C A S	9. D F R	10.	11.	12.
9. HULL NUMBER		13. IDENT./EQUIPMENT SERIAL NUMBER				14. EIC						
		C-123				P118						
15. SAFETY HAZARD <input type="checkbox"/>	16. LOCATION (Compartment/Deck/Frame/Side)					17. WHEN DISCLOSED DATE						
		CONFIGURATION CHANGE				FOR INSURRY USE						
18. ALTERATIONS (SHIPALT, ORGALT, P12 Chg, etc.)		19. #/00	20. HOUR NUMBER	21. SUFFIX	22. VESSEL	23. P/F						

BLOCK 13 - IDENT/EQUIPMENT SERIAL NUMBER

Enter the identification or serial number of the equipment or system on which maintenance is being performed:

NOTE (1): For electronics equipment, enter the serial number from the name plate of the equipment. Example: For AN/SPS-10C radar with serial number 48, the number "48" would be entered.

NOTE (2): If the serial number exceeds 12 characters, leave the block blank and enter "Serial Number" in the narrative, followed by the applicable number.

BLOCK 14 - EIC
(EQUIPMENT IDENTIFICATION CODE)

This code identifies the system, sub-system, or equipment on which maintenance was performed. In the event no EIC exists for the equipment on which maintenance was performed, enter the EIC of the next level: i.e., sub-system, or system. This code is obtained from the EIC MASTER INDEX.

3.1.1.1 2I

OPNAV 4790/2K (Rev. 6-73)		SHIP'S MAINTENANCE ACTION FORM (2-KILO)				COMP	DEF.
SECTION I. IDENTIFICATION		JOB CONTROL NUMBER					
1. SHIP'S LIC		2. WORK CENTER	3. JOB SEQ. NO.	4. APL/REL			
A. SHIP'S NAME		5. EQUIPMENT NAME				6. WNO	7. STA
8. HULL NUMBER		13. IDENT./EQUIPMENT SERIAL NUMBER		14. ETC		8. CAS	9. DFR
15. SAFETY HAZARD <input checked="" type="checkbox"/>		16. LOCATION (Compartment/Deck/Frame/Side)				17. WHEN DISCOVERED DATE	
		02-178-1-Q				6075	
19. ALTERATIONS (INSTALL, ORALTY, Fld Chg, etc.)		FOR INSURV USE					
SA-DD710-0023K							

BLOCK 15 - SAFETY HAZARD

An "X" will be placed in this block when, in the maintenance man's opinion, the documented maintenance action describes a problem or condition which has the potential to cause serious injury to personnel and/or serious damage to material. A brief explanation must be included in section IV - Remarks/Description.

BLOCK 16 - LOCATION
(COMPARTMENT/DECK/FRAME/SIDE)

Enter the location of the equipment or system on which the maintenance is being documented. It is made up of four elements separated by dashes (-).

NOTE (1): In those cases where a compartment number is not designated, the noun name of the deck should be used, for example "Fantail", "Flight Deck", etc.

BLOCK 17 - WHEN DISCOVERED DATE

Enter the Julian Date that the need for maintenance action was discovered. See Appendix 1.

BLOCK 18 - ALTERATIONS

If this maintenance action involves the performance of an alteration or field change, enter the identification as specified in the authorizing directive.

BLOCK 19 through 24 - FOR INSURV USE

For INSURV use only.

3.1.1.1 2I

SECTION III. COMPLETED ACTION	FOR SELECTED EQUIPMENTS ONLY																	
	29. ACT. TKN.	30. S/F MHRS.			31. COMPLETION DATE			32. ACT. MAINT. TIME	33. TI	34. METER READING								
	1	0	0	5	0	6	0	2	3	0	0	6	3	0	1	2	7	4

BLOCK 29 - ACT. TKN
(ACTION TAKEN)

Enter the code which best describes the situation. These codes shall always start in the left hand position of the block. Action codes are found in Appendix 6.

BLOCK 30 - S/F MHRS
(SHIP'S FORCE MAN HOURS)

Enter the total man hours spent on the maintenance action (to the nearest whole hour). Zeros (0) will be entered in all unused spaces to the left of the entry.

BLOCK 31 - COMPLETION DATE

Enter the Julian Date the Maintenance Action was completed. See Appendix 1.

BLOCK 32 - ACT. MAINT. TIME
(ACTIVE MAINTENANCE TIME)

Enter the total clock hours that the equipment was being worked on (to the nearest whole hour). Do not include any time not actually working on the equipment (i.e., waiting for parts, liberty, etc.).

BLOCK 33 - TI
(TROUBLE ISOLATION)

The percentage of active maintenance time (Block 32) that was spent in troubleshooting or isolating the trouble. Enter a single number to denote the percentage ("1" for 10%, "2" for 20%, "3" for 30%, etc.). If NONE enter "0".

BLOCK 34 - METER READING

If a specific time meter has been designated by the cognizant SYSCOM, the reading of this meter (to the nearest whole hour) at the time of repair is entered in this block.

NOTE: Blocks 32, 33, and 34 are used when reporting selected equipments only.

3.1.1.1 21

SECTION VI. REPAIR ACTIVITY PLANNING/ACTION									
48. REPAIR W/C	50. EST. MHRS.	51. ASST. REPAIR W/C	52. ASST. EST. MHRS.	53. SCHED. START DATE YR DAY	54. SCHED. COMP. DATE YR DAY				
55. REPAIR ACTIVITY UIC	56. WORK REQ. ROUTINE	57. EST. MANDAYS	58. EST. MANDAY COST \$	59. EST. MATERIAL COSTS \$					
60. EST. TOTAL COST \$	61. JOB ORDER NUMBER			62. LEAD PMS CODE	63. DATE OF EST. YR DAY				
64. FINAL ACT.	65. MHRS. EXPENDED	66. DATE COMPLETED YR DAY	G. COMPLETED BY (Signature - Rate)			H. ACCEPTED BY (Signature - Rate/Rate)			
			J J O' R ETR2			P P Jones ETC			

BLOCK G - COMPLETED BY

The senior man working on the job shall sign his name in this block and indicate his rate.

BLOCK H - ACCEPTED BY

The work center supervisor shall sign his name in this block and indicate his rate.

OPNAV 4790/2K (Rev. 6-73)				SHIP'S MAINTENANCE ACTION FORM (2-KILO)				COMP	DEFL		
SECTION I. IDENTIFICATION				JOB CONTROL NUMBER							
1. SHIP'S UIC 52176E0		2. WORK CENTER		3. JOB SEQ. NO. 000158981766		4. APL/REL.					
A. SHIP'S NAME USS ROGERS		B. EQUIPMENT NOM. NAME AN/SPS-10F		6. WND	7. STA	8. CLAS	9. DFR	10.	11.	12.	
C. HULL NUMBER DD876		D. IDENT./EQUIPMENT SERIAL NUMBER C-123		E. EIC P118		2216					
15. SAFETY HAZARD <input checked="" type="checkbox"/>		16. LOCATION (Compartment/Deck/Frame/Side) 02-178-1-Q				17. WHEN DISCOVERED DATE 8015					
18. ALTERATIONS (REPAI, ORDA, P12 Chg, etc.)				FOR INSURY USE							
SECTION II. DEFERRAL ACTION				19. S/F MHS. EXP.		20. DEFER. DATE		27. S/F MHS. REM.		28. DEADLINE DATE	
SECTION III. COMPLETED ACTION				29. ACT. TMR.		30. S/F MHS.		31. COMPLETION DATE		32. ACT. MAINT. TIME	
				1		00506		023006301274			
SECTION IV. REMARKS/DESCRIPTION											
35. REMARKS/DESCRIPTION 20A2 MONITOR SCOPE DIM AND FUZZY REPLACED CRT AND 1Z2 IN SWE EP GENERATOR BOARD											
37. COMP SUMMARY											
38. FIRST CONTACT/MAINT. MHN (Print)				39. RATE		40. SECOND CONTACT/SUPERVISOR (Print)				41. PRI	
C. DIV. INIT.				D. DEPT. INIT.		E. COMMANDING OFFICER'S SIGNATURE				F. TYCON AUTHORIZATION	
44. SPECIAL PURPOSE				45. IUC		46. TYCOM				47. CONT. SHEET	
SECTION V. SUPPLEMENTARY INFORMATION											
47. BLUEPRINTS, TECH. MANUALS, PLANS, ETC.						AVAILABLE ON BOARD		48. PREARRIVAL/ARRIVAL CONFERENCE ACTION/REMARKS			
						YES NO					
SECTION VI. REPAIR ACTIVITY PLANNING/ACTION											
49. REPAIR W/C		50. EST. MHS.		51. ASST. REPAIR W/C		52. ASST. EST. MHS.		53. SCHED. START DATE		54. SCHED. COMP. DATE	
								YR DAY		YR DAY	
55. REPAIR ACTIVITY UIC				56. WORK REQ. ROUTINE				57. EST. MANDAYS		58. EST. MANDRY COST \$	
60. EST. TOTAL COST \$				61. JOB ORDER NUMBER				62. LEAD P&E CODE		63. DATE OF EST.	
64. FINAL ACT.		65. MHS. EXPENDED		66. DATE COMPLETED		67. COMPLETED BY (Signature - Rate)			68. ACCEPTED BY (Signature - Rate/Rank)		
						JJ Doe ETR2			PP Jones ETC		

OPNAV 4790/2K, Ships Maintenance Action Form

JULIAN DATE CALENDAR

(PERPETUAL)

Day	Jan	Feb	Mar	Apr	May	June	July	Aug	Sep	Oct	Nov	Dec	Day
1	001	032	060	091	121	152	182	213	244	274	305	335	1
2	002	033	061	092	122	153	183	214	245	275	306	336	2
3	003	034	062	093	123	154	184	215	246	276	307	337	3
4	004	035	063	094	124	155	185	216	247	277	308	338	4
5	005	036	064	095	125	156	186	217	248	278	309	339	5
6	006	037	065	096	126	157	187	218	249	279	310	340	6
7	007	038	066	097	127	158	188	219	250	280	311	341	7
8	008	039	067	098	128	159	189	220	251	281	312	342	8
9	009	040	068	099	129	160	190	221	252	282	313	343	9
10	010	041	069	100	130	161	191	222	253	283	314	344	10
11	011	042	070	101	131	162	192	223	254	284	315	345	11
12	012	043	071	102	132	163	193	224	255	285	316	346	12
13	013	044	072	103	133	164	194	225	256	286	317	347	13
14	014	045	073	104	134	165	195	226	257	287	318	348	14
15	015	046	074	105	135	166	196	227	258	288	319	349	15
16	016	047	075	106	136	167	197	228	259	289	320	350	16
17	017	048	076	107	137	168	198	229	260	290	321	351	17
18	018	049	077	108	138	169	199	230	261	291	322	352	18
19	019	050	078	109	139	170	200	231	262	292	323	353	19
20	020	051	079	110	140	171	201	232	263	293	324	354	20
21	021	052	080	111	141	172	202	233	264	294	325	355	21
22	022	053	081	112	142	173	203	234	265	295	326	356	22
23	023	054	082	113	143	174	204	235	266	296	327	357	23
24	024	055	083	114	144	175	205	236	267	297	328	358	24
25	025	056	084	115	145	176	206	237	268	298	329	359	25
26	026	057	085	116	146	177	207	238	269	299	330	360	26
27	027	058	086	117	147	178	208	239	270	300	331	361	27
28	028	059	087	118	148	179	209	240	271	301	332	362	28
29	029		088	119	149	180	210	241	272	302	333	363	29
30	030		089	120	150	181	211	242	273	303	334	364	30
31	031		090		151		212	243		304		365	31

FOR LEAP YEAR USE REVERSE SIDE

JULIAN DATE CALENDAR

FOR LEAP YEARS ONLY

Day	Jan	Feb	Mar	Apr	May	June	July	Aug	Sep	Oct	Nov	Dec	Day
1	001	032	061	092	122	153	183	214	245	275	306	336	1
2	002	033	062	093	123	154	184	215	246	276	307	337	2
3	003	034	063	094	124	155	185	216	247	277	308	338	3
4	004	035	064	095	125	156	186	217	248	278	309	339	4
5	005	036	065	096	126	157	187	218	249	279	310	340	5
6	006	037	066	097	127	158	188	219	250	280	311	341	6
7	007	038	067	098	128	159	189	220	251	281	312	342	7
8	008	039	068	099	129	160	190	221	252	282	313	343	8
9	009	040	069	100	130	161	191	222	253	283	314	344	9
10	010	041	070	101	131	162	192	223	254	284	315	345	10
11	011	042	071	102	132	163	193	224	255	285	316	346	11
12	012	043	072	103	133	164	194	225	256	286	317	347	12
13	013	044	073	104	134	165	195	226	257	287	318	348	13
14	014	045	074	105	135	166	196	227	258	288	319	349	14
15	015	046	075	106	136	167	197	228	259	289	320	350	15
16	016	047	076	107	137	168	198	229	260	290	321	351	16
17	017	048	077	108	138	169	199	230	261	291	322	352	17
18	018	049	078	109	139	170	200	231	262	292	323	353	18
19	019	050	079	110	140	171	201	232	263	293	324	354	19
20	020	051	080	111	141	172	202	233	264	294	325	355	20
21	021	052	081	112	142	173	203	234	265	295	326	356	21
22	022	053	082	113	143	174	204	235	266	296	327	357	22
23	023	054	083	114	144	175	205	236	267	297	328	358	23
24	024	055	084	115	145	176	206	237	268	298	329	359	24
25	025	056	085	116	146	177	207	238	269	299	330	360	25
26	026	057	086	117	147	178	208	239	270	300	331	361	26
27	027	058	087	118	148	179	209	240	271	301	332	362	27
28	028	059	088	119	149	180	210	241	272	302	333	363	28
29	029	060	089	120	150	181	211	242	273	303	334	364	29
30	030		090	121	151	182	212	243	274	304	335	365	30
31	031		091		152		213	244		305		366	31

(USE IN 1964, 1968, 1972, etc.)

GPO:1976-0-622-037

3.1.1.1 2I

APPENDIX 2
WHEN DISCOVERED CODES
(BLOCK 6)

These codes are designed to depict the circumstances under which the need for maintenance was discovered.

1 = Lighting Off or Starting

2 = Normal Operation

3 = During Operability Tests

4 = During Inspection

5 = Shifting Operational Modes

6 = During PMS

7 = Securing

∅ = Not Applicable (to be used when reporting a configuration change, printing services, etc.)

APPENDIX 3
STATUS CODES
(BLOCK 7)

These codes are used to describe the effect of the failure or malfunction on the operational performance capability of the equipment. the "NOT APPLICABLE" code is to be used when there has been no malfunction, i.e., alteration, field change, printing services, PMS actions, etc.

- 1 = Operational
- 2 = Non-Operational
- 3 = Reduced Capability
- 4 = Not Applicable

APPENDIX 4
CAUSE CODES
(BLOCK 8)

This cause code is designed to aid the Maintenance Man in reporting his opinion of what basic factor caused the malfunction when the need for maintenance was first discovered. When more than one reason (cause) contributed to the malfunction/failure select the primary/overriding cause. Selection of this code should be made only after careful consideration of all the factors involved in the failure.

<u>CODE</u>	<u>CAUSE</u>	<u>DESCRIPTION</u>
1	Abnormal environment	Exposure to condition more extreme than those reasonably expected in the normal shipboard environment.
2	Manufacturer/installation defects	Material not manufactured or assembled according to specifications (Note: In these cases, a defective material report should be submitted in accordance with NAVSUPINST 4440.120C); or equipment not installed properly by IMA or depot.
3	Lack of knowledge or skill	Inadequate performance due to insufficient training, experience or physical coordination.
4	Communication problems	A breakdown in the passing, receiving or understanding of information.
5	Inadequate instruction/procedure	The instruction or procedural guide specified has omissions, errors, ambiguities or other deficiencies.
6	Inadequate design	Material which was manufactured and installed in accordance with specifications failed prematurely during normal usage under normal environmental conditions.

APPENDIX 4 (cont'd)

<u>CODE</u>	<u>CAUSE</u>	<u>DESCRIPTION</u>
7	Normal wear and tear	Material requires replacement after long service and/or as a result of PMS. Since selection of cause code 7 may require a knowledge of design or expected length of service, this may require the work center supervisor to seek advice form higher authority.
Ø	Not applicable (no mal-function) or other	(Explain in remarks)

APPENDIX 5
DEFERRAL REASON
(BLOCK 9)

The deferral reason codes are used to describe the reason maintenance cannot be done at the time of deferral.

<u>CODE</u>	<u>DEFERRAL REASON</u>	<u>WORK FOR WHICH CODE IS USED</u>
1	Due to ship's force work backlog/operational priority	Within capability of ship to accomplish but unable to do so because of ship's overall workload or operational considerations.
2	Lack of material	Within capability of ships force but unable to accomplish due to lack of parts; or lack of tools, test equipment, etc., which are on ship's allowance
3	No formal training in this equipment	Should be within capability of ship's force but personnel responsible have not received formal training in the maintenance of the equipment.
4	Formal training inadequate	Should be within capability of ship's force, and personnel responsible have received formal training but that training is considered inadequate.
5	Inadequate school practical training	Should be within capability of ship's force, and personnel responsible have received formal training, but practical maintenance aspects of training are considered inadequate.
6	Lack of facilities/capabilities	The ship is not allowed ship equipment or other facilities to accomplish; or work is otherwise beyond expected capabilities of ship's force to accomplish.

APPENDIX 5 (cont'd)

<u>CODE</u>	<u>DEFERRAL REASON</u>	<u>WORK FOR WHICH CODE IS USED</u>
7	Not authorized for ship's force accomplishment	Directive of higher authority specify that job will be done by other than ships force.
8	For ship's force overhaul or availability work list	For jobs to be done by ship's force during forthcoming overhaul or availability.
9	Lack of technical documentation	Should be within capability of ship to accomplish but unable to do so because technical manuals, blueprints, drawings, etc., not available.
Ø	Other - or not applicable	If "other," describe in "remarks."

APPENDIX 6
ACTION TAKEN CODES
(BLOCK 29/64)

These codes are used to describe the action taken. When entering these codes, they shall always start in the left-hand position of the block.

- 1 = Maintenance action completed; parts drawn from supply
- 2 = Maintenance action completed; required parts not drawn from supply (local manufacture, pre-expended bins, etc.)
- 3 = Maintenance action completed; no parts required
- 4 = Canceled (When this code is used, the deferral will be removed from the CSMP).
- 5 = Configuration Change (When this code is used, one of the following suffix codes which best describes the configuration change will be placed in the second position of the action taken block).
 - A = Partially completed alteration/field change
 - B = Fully completed alteration/field change
 - C = Equivalent alteration completed
 - D = Alteration/field change directive cited is not applicable
 - E = Exchange (removed one equipment and installed another)
 - F = Removed equipment (No exchange)
 - G = Installed equipment (No exchange)
- *6 = Rejected Work Request (Add suffix as follows to indicate reason)
 - A = Ship's Force/Standard Stock Item
 - B = Excessive Shop Workload/Insufficient Availability
 - C = Lack of Skills
 - D = Lack of Facilities

3.1.1.1 2I

APPENDIX 6 (cont'd)

E = Lack of Test or Calibration Equipment

F = Lack of Parts/Material

G = Lack of Documentation

H = Lack of funds

I = Other (Explain in Block 35)

Ø = None of the above. Describe in Remarks/Description Section.

*Block 64 only.

JOB SHEET

R1051B/URR: Operation and Familiarization

JOB SHEET NO. 3.1.1.1 1J

INTRODUCTION:

This job sheet will provide hands on experience in operating a R-1051B/URR Radio Receiver for maintenance purposes. It will involve physically inspecting the receiver, performing operational tests and checks utilizing Maintenance Requirement Card (MRC'S).

These experiences are necessary for a technician to determine the status of his equipment. The operational checks will aid in determining if a malfunction exists. Physical inspection is a key element in preventive and corrective maintenance.

LESSON TOPIC LEARNING OBJECTIVE(S):

3.1.1.1.2 VERIFY the operation of the R-1051B/URR Receiver in accordance with Maintenance requirement Card C-304 W1, given the MRC, technical manual, tools, and test equipment.

3.1.1.1.3 INSPECT the R-1051B/URR Receiver in accordance with Maintenance Requirement Card C-304 S-1, given the MRC, tools and technical manual.

3.1.1.1.4 VERIFY the operation of the R-1051V/URR Receiver interlock system in accordance with Maintenance Requirement Card C-304 S-4, given tools and the MRC.

REFERENCES:

NAVSHIPS 0967-427-4010 Technical Manual for Radio Receiver, Vol 1.

NAVSHIPS 0967-427-4020 R-1051B/URR Technical Manual, Vol II

OPNAV 4700-1 (A), Maintenance Requirement Card (MRC) Rev 3-69 BBM4
dated January 1975

OPNAV 4700-1 Maintenance Requirement Card (MRC) CDQ6 dated January 1978

OPNAV 4700-1 Maintenance Requirement Card (MRC) CBTO dated October 1979

3.1.1.1 1J

EQUIPMENT AND MATERIALS

1. R-1051B/URR Radio Receiver
2. Maintenance Requirement Cards C-304, W-1 and C-304, S-4

General: Observe all safety precautions.

JOB STEPS.

Part I: TEST/OPERATE RADIO RECEIVER

During this part you will be making adjustments to different controls and observing indications for desired responses. This should not be just a mechanical action on your part but rather be alert to the indications as both normal and abnormal ones are clues to a well trained mind.

1. Obtain a tool kit for your position from the lab instructor.
2. Refer to the Maintenance Requirement Card (MRC) C-304 W-1 on the following pages and perform all the steps on the MRC, this MRC has been modified to meet the needs of the Lab. It is not the Actual C-304 W-1 MRC used in the fleet.

3.1.1.1 1J

SHIP SYSTEM COMBAT		SUBSYSTEM Transceiver		MRC CODE C-304 W-1	
SYSTEM Communications		EQUIPMENT AN/WRC-1, 1B Radio Set R-1051, 1051B/URR Radio Receiver		RATES RMSN	M/H 0.2
MAINTENANCE REQUIREMENT DESCRIPTION 1. Test operate radio receiver.				TOTAL M/H 0.2 ELAPSED TIME 0.2	
SAFETY PRECAUTIONS 1. Comply with Navy Safety Precautions for Forces Afloat, OPNAVINST 5100 series.					
TOOLS, PARTS, MATERIALS, TEST EQUIPMENT 1. Headset					
PROCEDURE 1. Test operate Radio Receiver. a. Loosen retaining screws and withdraw chassis approximately 2" inches. b. Set the AUX/NORM switch to NORM. c. Set the Simplex/Duplex switch to Simplex. d. Slide receiver into normal position and tighten retaining screws.					
LOCATION				DATE	

PAGE 1 OF 2

MAINTENANCE REQUIREMENT CARD (MRC)

PROCEDURE (CONT)

- e. Set MODE SELECTOR switch to ISB; allow a 5-minute warm-up.
- f. Ensure receiver is not patched to any undesired listening position.
- g. Patch antenna to receiver.
- h. Set receiver switches and controls:
 - (1) CPS to 000
 - (2) RF GAIN fully clockwise.
 - (3) USB and ISB LINE LEVEL meter switches to +20 dB
 - (4) USB and LSB LINE LEVEL fully clockwise
 - (5) USB and LSB PHONE LEVEL to approximately midrange

NOTE 1

- i. Monitor a WWV, WWVH, or a known tone-modulated signals; USB and LSB LINE LEVEL meters should indicate simultaneously when station's carrier is modulated. Tones of intelligence coincidental with LINE METER indications should be heard in the headset plugged into ISB, then USB PHONE jacks; PHONE LEVEL controls may be adjusted for a comfortable listening level.
- j. Set CPS switch to VERNIER; indicator lamp should flash on and off. Tone in headset should vary as VERNIER control is rotated.
- k. For R-1501/URR only, set CPS switch to 500; verify that tone in headset changes pitch.
- l. For R-2051B/URFF only, rotate CPS switch from 300 through 900; verify that tone in headset changes pitch at each position.
- m. Set CPS switch to 000
- n. Set MODE SELECTOR to CW and rotate BFO FREQ control through its range; pitch of tone in headset should vary as BFO FREQ control is rotated.
- o. Set MODE SELECTOR to AM; a clear tone should be heard in headset when carrier is tone-modulated.
- p. Set MODE SELECTOR to FSK and tune receiver to a known FSK frequency; a tone shifting in frequency (or pitch) should be heard in the headset.
- q. Return equipment to normal readiness condition.

NOTES:

- 1. The following frequencies may be used in checking the Receiver operation
 - WWV=
 - AM/SSB=
 - FSK=

SHEET 2 OF 2

3.1.1.1 1J

PART II: TEST RECEIVER INTERLOCK

1. Refer to the Maintenance Requirement Card (MRC) C-304 S-4 on the following pages and perform all the steps on the MRC (Figure 2), for the steps below respond to the questions.

1.b. Vernier Lamp Flashing? yes _____ no _____

 e. Vernier Lamp Flashing? yes _____ no _____

3.1.1.1 1J

SHIP SYSTEM COMBAT		SUBSYSTEM		MRC CODE C-304 S-4	
SYSTEM		EQUIPMENT AN/WRC-1, 2B Radio Set R-1051, 1051B, D, E/URF Radio Receiver		RATES ETN3	M/H 0.1
MAINTENANCE REQUIREMENT DESCRIPTION 1. Test receiver interlock				TOTAL M/H 0.1 ELAPSED TIME 0.1	
SAFETY PRECAUTIONS 1. Forces afloat comply with Navy Safety Precautions for Forces Afloat, OPNAVINST 5100 series.					
TOOLS, PARTS, MATERIALS, TEST EQUIPMENT 1. 6" Normal duty screwdriver					
PROCEDURE 1. Test Receiver Interlock. a. Set receiver switches and controls: (1) Mode selector to position other than OFF or STBY (2) CPS (Hz) selector to V b. Verify that vernier indicator lamp is flashing c. Set mode selector switch to OFF d. Loosen retaining screws and withdraw chassis approximately 2 inches. e. Set mode selector switch to LSB; verify that vernier indicator lamp is not flashing. f. Set mode selector switch to OFF. g. Slide receiver into normal position and tighten retaining screws. h. Return equipment to current readiness condition.					
LOCATION				DATE	

PAGE
OF

MAINTENANCE REQUIREMENT CARD (MRC)

3.1.1.1 1J

PART III INSPECT RECEIVER

In this part you will not be accomplishing all the steps of the procedure as called for on the Maintenance Requirement Card. You will be required to read all steps and take note of the actions called for.

1. Refer to Maintenance Requirement Card (MRC) C-304 S-1 on the following pages and perform all the steps with an asterick (*) beside them. For the steps below respond to the question.

1.a. Was there excessive drag when sliding chassis out? yes _____ no _____

b. Digit indicators centered? yes _____ no _____

g. Discrepancies yes _____ no _____

If yes List

h. (1) Excessive slack yes _____ no _____

(2) Detent springs seating properly yes _____ no _____

(3) Damaged springs yes _____ no _____

i. Proper Lubrication yes _____ no _____

j. Locks engage? yes _____ no _____

2. Have instructor check your Job Sheet before securing the position

Instructor Signature

3. Return Tool Kits

SHIP SYSTEM COMBAT	SUBSYSTEM	MRC CODE C-304 S-1											
SYSTEM	EQUIPMENT AN/WRC-1, 1B Radio Set R-1051, 1051B/URR Radio Receiver	RATES RMSN	M/H 0.2										
MAINTENANCE REQUIREMENT DESCRIPTION 1. Clean, inspect and lubricate receiver		TOTAL M/H 0.2 ELAPSED TIME 0.2											
SAFETY PRECAUTIONS 1. Forces afloat comply with Navy Safety Precautions for Forces Afloat, OPNAVINST 5100 series.													
TOOLS, PARTS, MATERIALS, TEST EQUIPMENT <table border="0" style="width: 100%;"> <tr> <td>1. Clean rags</td> <td>6. Grease, MIL-G-23827</td> </tr> <tr> <td>2. Warning tag</td> <td>7. 6" Normal duty screwdriver</td> </tr> <tr> <td>3. Dusting brush</td> <td>8. Flashlight</td> </tr> <tr> <td>4. Oil, MIL-L-6085</td> <td></td> </tr> <tr> <td>5. Vacuum cleaner with non-metallic nozzle</td> <td></td> </tr> </table>				1. Clean rags	6. Grease, MIL-G-23827	2. Warning tag	7. 6" Normal duty screwdriver	3. Dusting brush	8. Flashlight	4. Oil, MIL-L-6085		5. Vacuum cleaner with non-metallic nozzle	
1. Clean rags	6. Grease, MIL-G-23827												
2. Warning tag	7. 6" Normal duty screwdriver												
3. Dusting brush	8. Flashlight												
4. Oil, MIL-L-6085													
5. Vacuum cleaner with non-metallic nozzle													
PROCEDURE Preliminary a. Set mode selector switch to OFF. b. Turn OFF and tag bulkhead power switch. 1. Clean, Inspect and Lubricate Receiver. * a. Loosen retaining screws and withdraw chassis until mechanical stops engage. * b. Rotate MCS/MHz and KCS/kHz controls through entire range, each digit indicator should be centered in window. * c. Release locks and tilt chassis upward 90 degrees. d. Wipe accessible surfaces with a clean rag. e. Use brush to remove dust and dirt from areas not easily accessible. f. Remove remaining dust and dirt with a vacuum cleaner. * g. Inspect interior of equipment for bulged for leaking capacitors, discolored or scorched components, cracked or frayed insulation, loose connections, and presence of foreign matter.													
LOCATION	DATE												

PROCEDURE (CONT)

- * h. Rotate each MCS/MHz and KCS/kHz control. Look for:
 - (1) Slack caused by loose chain tension idler gear assembly nuts
 - (2) KCS/kHz dual sprocket assembly detent springs seating properly on detent wheel
 - (3) Cracked or damaged MCS/MHz and KCS/kHz detent springs

NOTE 1 * Inspect gear teeth and chains for proper lubrication. If grease is dry or dirty:

- (1) Remove old grease with a clean, lint-free rag.
 - (2) Apply a thin film of grease to chains and exposed gear teeth.
 - (3) Apply 2 drops of oil to drive gear bearings.
 - (4) Rotate controls to distribute grease evenly.
 - (5) Remove excess lubricant with a clean, lint-free rag.
- * j. Release locks and lower chassis to horizontal position; to ensure locks engage.
 - * k. Release catches, slide chassis into cabinet, and tighten retaining screws.
 - * l. Return equipment to current readiness condition.

NOTES:

- 1. Inspect only and record status.

SHEET 2 OF 2

3.1.1.1 1J

Self Test Items:

1. Into what phone jack must the headset be plugged during AM operation?
2. When will the vermier light flash?
3. During the mode of operation would you use the BFO control?
4. The line level switches have two positions. Why?
5. Which phone level control would you use to adjust the headset audio when the receiver is in FSK?
6. What is the front panel indication if a fuse is blown?

NOTETAKING SHEET

R-1051B/URR FRONT PANEL CONTROLS

NOTETAKING SHEET: 3.1.1.1 1N

REFERENCES:

NAVSHIPS 0967-427-4020 Vol. II R-1051B/URR Technical Manual
NAVELEX 0967-LP-427-5020 AN/WRC-1B Technical Manual

NOTETAKING:

This notetaking sheet is provided for you to record the reference DRS designations and functions of the front panel controls for the R-1051B/URR.

3.1.1.1 1N

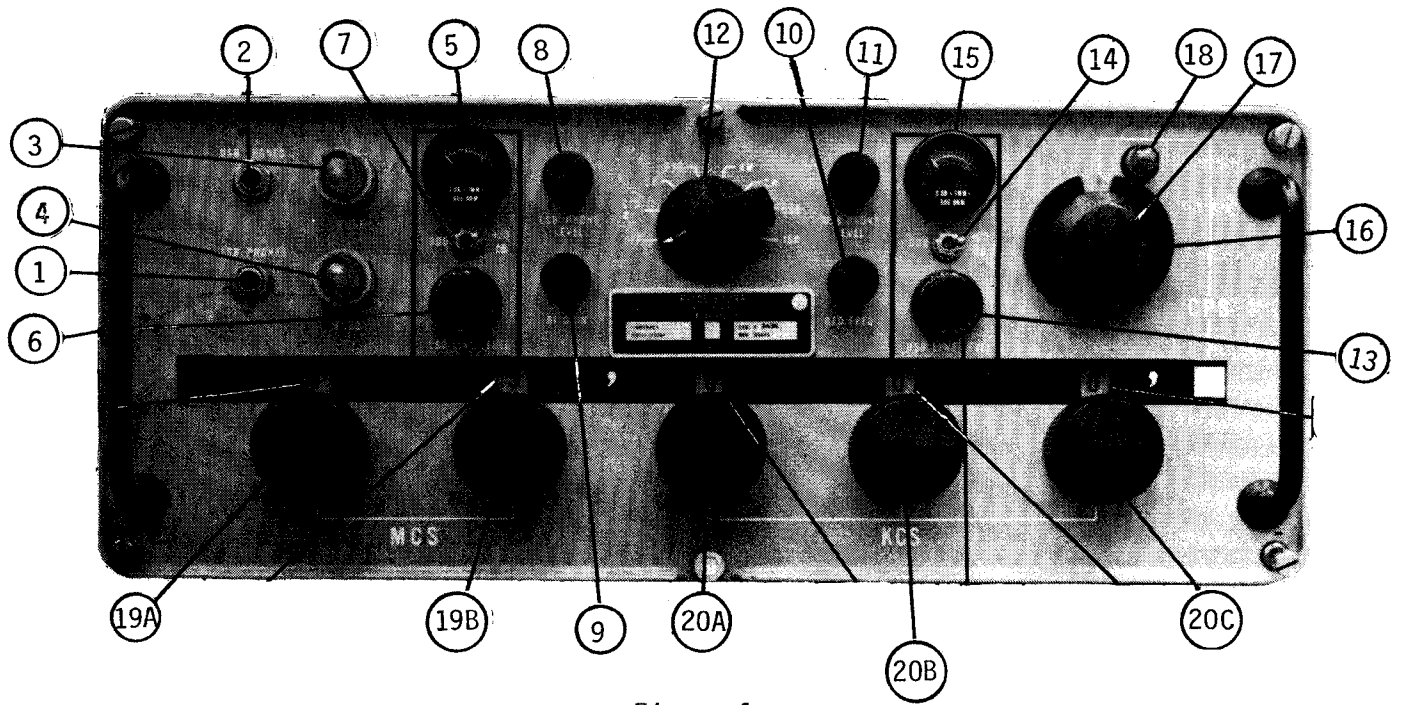

Figure 1

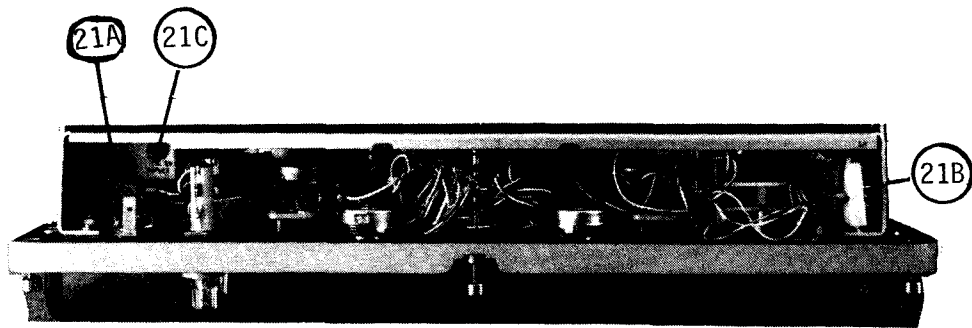

Figure 2

3.1.1.1 1N

Ref. Design.	FUNCTION
1	<hr/> <hr/> <hr/> <hr/> <hr/>
2	<hr/> <hr/> <hr/> <hr/> <hr/>
3	<hr/> <hr/> <hr/> <hr/> <hr/>
4	<hr/> <hr/> <hr/> <hr/> <hr/>
5	<hr/> <hr/> <hr/> <hr/> <hr/>

3.1.1.1 1N

Ref. Design.	FUNCTION
6	
7	
8	
9	
10	

3.1.1.1 IN

Ref. Design.	FUNCTION
11 _____	_____ _____ _____ _____ _____
12 _____	_____ _____ _____ _____ _____
13 _____	_____ _____ _____ _____ _____
14 _____	_____ _____ _____ _____ _____
15 _____	_____ _____ _____ _____ _____

3.1.1.1 1N

Ref. Design.	FUNCTION
16 _____	_____ _____ _____ _____
17 _____	_____ _____ _____ _____
18 _____	_____ _____ _____ _____
19A _____	_____ _____ _____ _____
19B _____	_____ _____ _____ _____

3.1.1.1 1N

Ref. Design.	FUNCTION
20A _____	_____ _____ _____ _____ _____
20B _____	_____ _____ _____ _____
20C _____	_____ _____ _____ _____
21A _____	_____ _____ _____ _____
21B _____	_____ _____ _____ _____ _____

3.1.1.1 1N

Ref. Design.

FUNCTION

21C _____

ASSIGNMENT SHEET 3.1.1.2 1A

R-0151B/URR FUNCTIONAL BLOCK ANALYSIS

INTRODUCTION:

This assignment sheet is comprised of two parts. Part I is designed to give practice using the Technical Manual and the Functional Block Diagram to obtain information.

Part II is a reading assignment on the following circuit: Antenna Overload, RF Amplifier, Translator/Synthesizer, and Frequency Standard circuits of the R-1051B which will prepare you for the next lesson topics.

Part III will aid you in troubleshooting the R-1051/URR Receiver

LESSON TOPIC OBJECTIVES:

3.1.1.2.1 IDENTIFY the function of each block in the R-1051B/URR Functional Block Diagram by matching the name of each block to its function, given the block diagram and a list of functions.

3.1.1.2.2 IDENTIFY signal distribution on the R-1051B/URR Functional Block Diagram by matching each signal designation to the statement describing its distribution path, given the Functional Block Diagram, a set of signal designations, and a set of statements describing signal distribution paths.

STUDY ASSIGNMENT: PART I: R-1051B/URR Technical Manual and Functional Block Analysis

Review classroom lesson topic material and notes.

STUDY QUESTIONS: Refer to Homework Handout

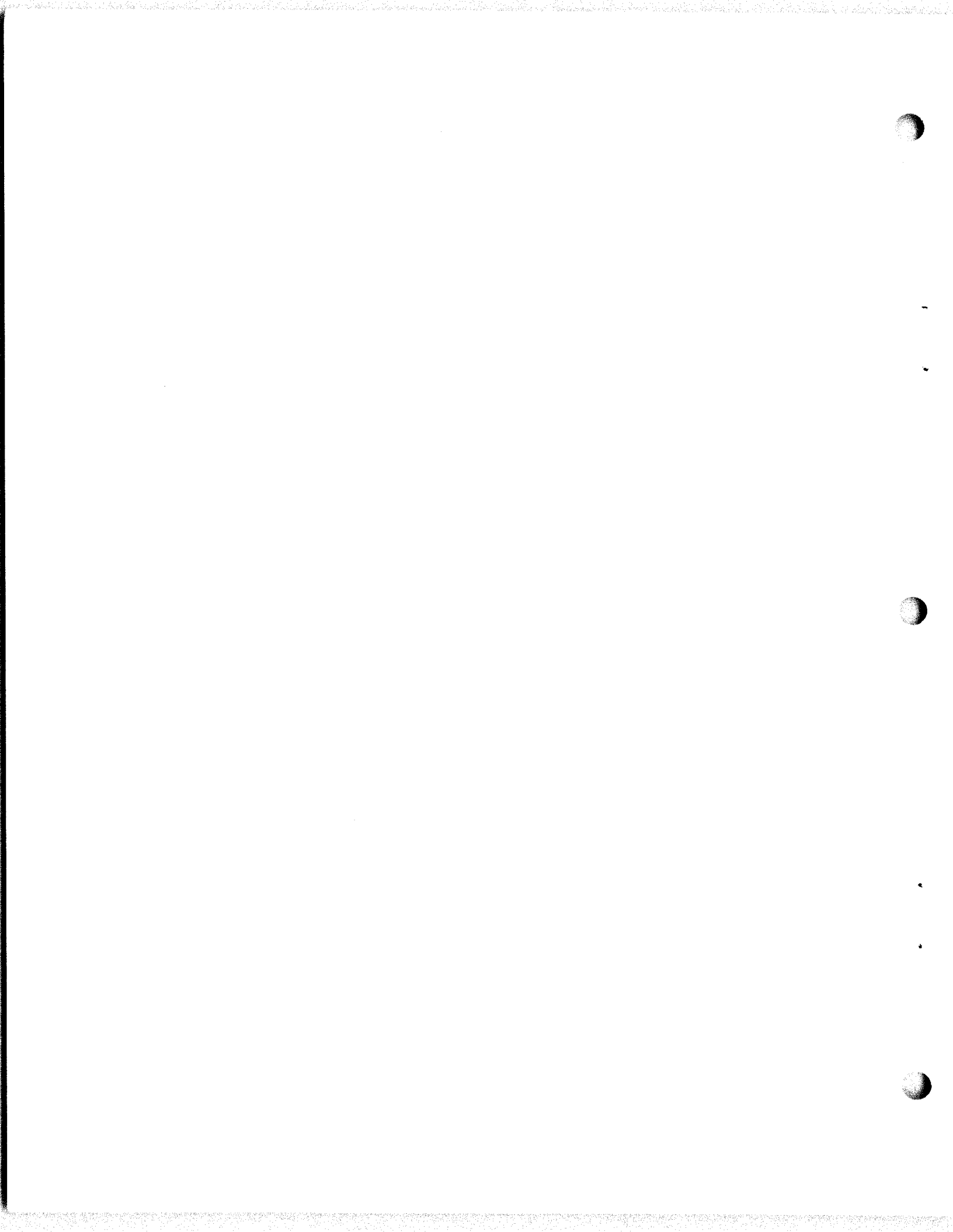

3.1.1.2 1A -H

Part III R-1051B Troubleshooting analysis.

The SYMPTOM column lists what mode(s) the R-1051B will not receive. In the POSSIBLE TROUBLE column list the NAME and REFERENCE DESIGNATION of the possible faulty module(s). In addition, if you choose module A2A1, A2A2 or A2A3, list the possible faulty circuit board or filter within that particular module.

SYMPTOM	POSSIBLE TROUBLE
FSK, AM, CW, USB ISB(USB)	
AM, CW	
ANY MODE	
LSB, ISB(LSB)	
SSB, FSK	
USB, FSK ISB(USB)	
CW	
FSK, AM, CW, USB, ISB	
CAN'T ADJUST BFO FREQUENCY	

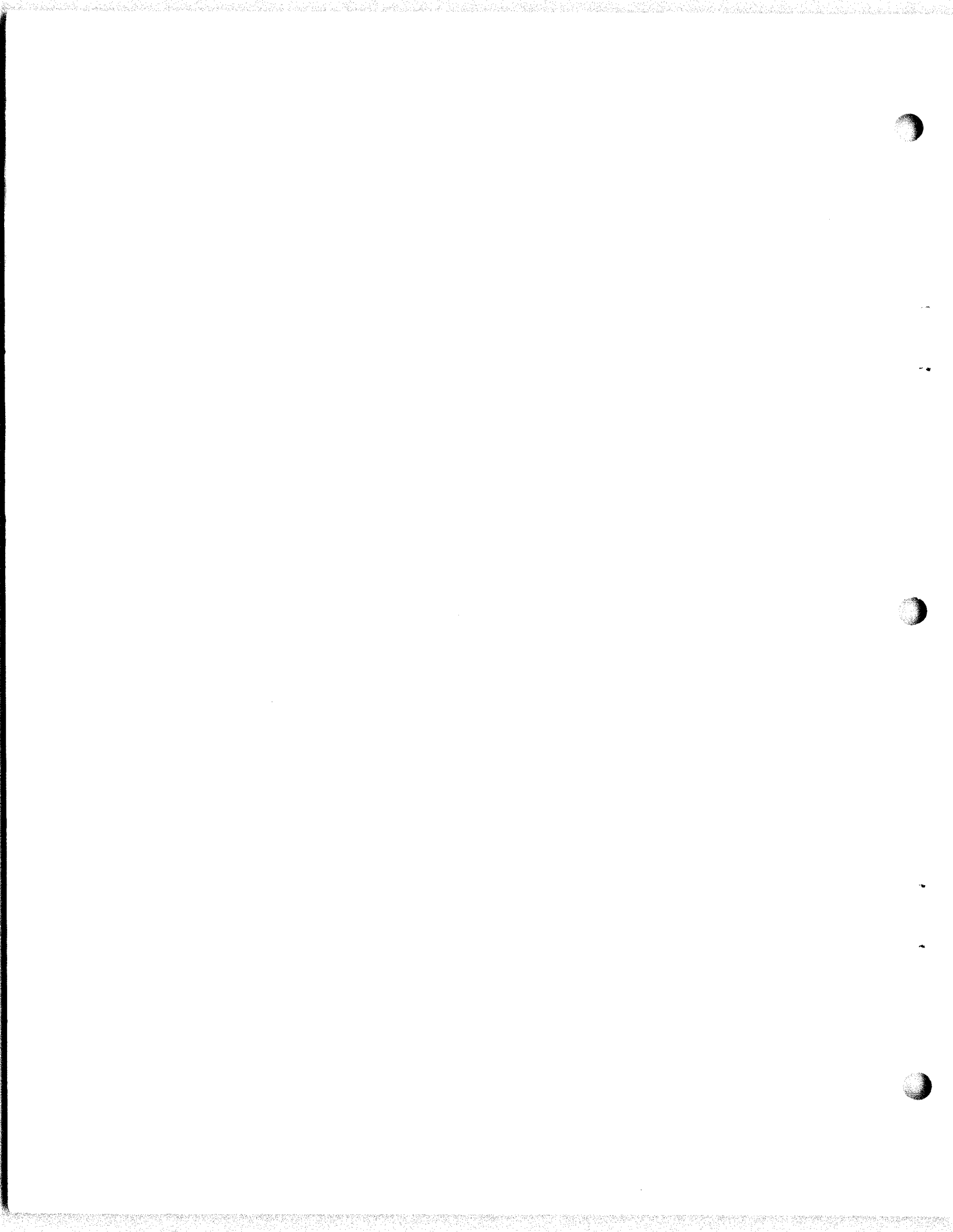

SUBASSEMBLY HANDLING AND TEST TECHNIQUES

INTRODUCTION

Removal, testing, and reinstallation of the module assemblies is a common requirement in the maintenance of many electronic equipment. The precautions inherent to this task apply not only to the R-1051B, but also to most modular type electronic equipments. This Information Sheet has been designed to familiarize you with these precautions and techniques.

REFERENCES

NAVELEX 0967-LP-427-4010, Volume I, Technical Manual for Radio Receiver R-1051B/URR

NAVSHIPS 0967-427-4020, Volume II, Technical Manual for Radio Receiver R-1051B/URR

NAVELEX 0967-LP-427-5020, Technical Manual for AN/WRC-1B

NAVELEX 0967-LP-970-9010, Volume I, Technical Manual for R-1051B/URR

INFORMATION

1. The R-1051 consists of two assemblies:
 - a. The receiver cabinet 1A1.
 - b. The receiver main frame 1A2.
2. The Main Frame provides stable mounting and interconnection of the various modular subassemblies and their associated controls. The inter-connection is accomplished through plugs/jacks and associated wiring harnesses.
3. Secure mounting is provided by the close arrangement of modules and by securing modules with mounting fasteners (screws). These modular subassemblies are relatively rugged, but may be damaged or knocked out of adjustment by:
 - a. Improper removal/installation techniques.
 - b. Improper test techniques.
 - c. Rough handling.
 - d. Improper packaging for shipment.
4. Removal Techniques: (CAUTION - Before removing any modular assembly, position Mode Select switch on front panel to "OFF".)

3.1.1.2 11

- a. The RF Filter subassembly 1A1A1, mounted in the Receiver Cabinet 1A1, is a very low failure item and will not normally require service. For this reason it is NOT a plug in type module. If service should be required, the front cover is removable to provide access to the filter components.
 - b. The Receiver Mode Selector 1A2A1 is a main frame plug in subassembly. It may be easily removed by loosening each of the two (2) captive screws which secure it to the main frame. These screws, located on the CORNERS of the module (as they are on the other "plug in" modules) need not be completely removed, but require loosening to the point of "free movement" in the vertical direction. They should slide freely for about one inch and then stop. The module may then be removed by grasping these screws and pulling gently in a vertical direction with a slight rocking motion until the module is free of the main frame.
5. After removing a module, take care to place it on a clean stable surface. Place it in a position which will not damage any connectors, plugs, controls, or projecting mechanical couplings as illustrated by Figure 1.

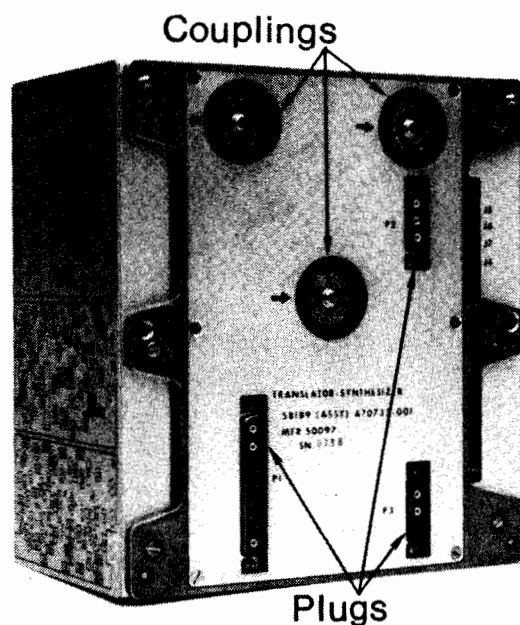

Figure 1

6. Testing a module by using the Input Conversion Output (ICO) technique normally is accomplished by using test points provided on the particular module. In the labs at ET school some of the test points have become disconnected from the circuit boards due to excessive use, therefore we will use a different technique. The module being tested will be removed and a signal check taken at its input, if the inputs are good replace that module and remove the next module in the signal path. To check that module's inputs we will also consider the output of the preceding module, so we will really be checking two points at the same time.

7. Module Reinstallation:

- a. Prior to placing a module in the main frame, check the connector pins in the main frame and the module assembly to ensure they are not bent. Reinstallation of the module into the main frame requires particular attention be given to alignment of all plugs and mechanical connections to prevent damaged pins, stripped screws and bent mechanical components. Align the module properly in the main frame, and gently lower it into place by grasping two mounting screws. When the module is in position, gently press and rock the corners of the module to seat the connectors. Secure the mounting screws by tightening each to the point of a just perceived resistance. Then alternately tighten each about one-half turn until they are all seated (moderate resistance only--do not overtighten).
- b. The precautions for the other assemblies in the R-1051 are the same as those previously outlined with the following exceptions:
 - (1) RF Amplifier 1A2A4 and Translator/Synthesizer 1A2A6 are mechanically coupled to the front panel KCS controls. These controls should be positioned to the "0" digit position prior to removal of the module. Replacement modules are also positioned on "0" at the repair depot to facilitate ease of assembly. This position may be verified by checking the bottom to the module and verifying the "0" marks on the couplings are aligned with the index marks on the module case (base). See Figure 2.

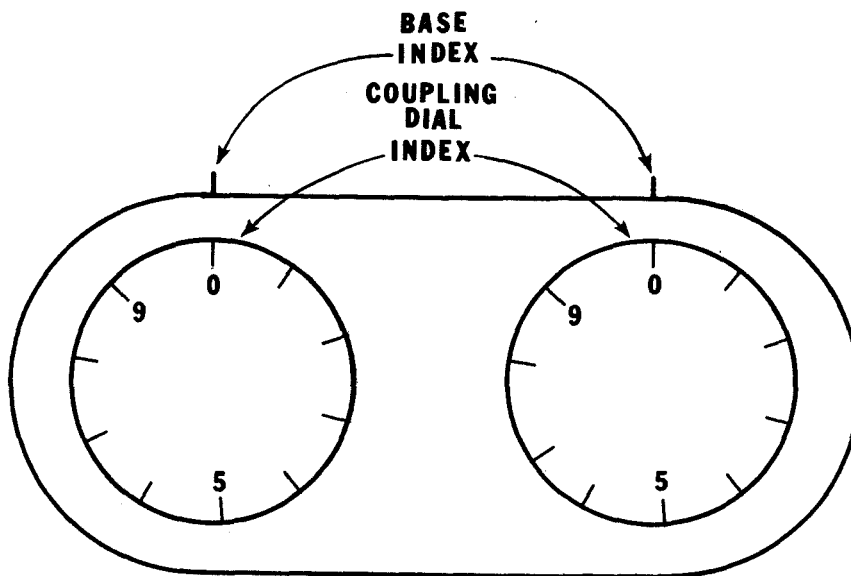

Figure 2

3.1.1.2 II

- (2) The Code Generator 1A2A7 is connected to the MCS controls. The controls should be positioned to the "0" digit position before removing the subassembly. The wiring harness for the A7 subassembly is sufficiently long to facilitate testing of the master and image code switches without the use of an extender cable. Failure of this subassembly is relatively common, but repair is usually facilitated by cleaning/adjusting the switches and switch contacts. (CAUTION - Deenergize the equipment prior to cleaning and/or adjusting switch contacts.)
- (3) The Power Supply 1A2A8 and the Antenna Overload 1A2A9 Subassemblies must be tested in place. Access to the components is achieved by removing the mounting screws. The fault may then be corrected, and the board replaced.

JOB SHEET

R-1051B/URR SIGNAL VERIFICATION

JOB SHEET NO. 3.1.1.2 1J

INTRODUCTION:

This job sheet will provide you with hands on experience in module signal tracing for the purpose of verifying input and output signals. It will involve physically removing modules, performing operational tests, and physical inspection of connections.

A point is reached during the course of logical troubleshooting that the technician must check out whether a function is or is not performing properly. This is where your knowledge of the functional block, the functional relationships and input/output requirements will allow you to isolate the faulty function of module.

LESSON TOPIC LEARNING OBJECTIVE(S):

3.1.1.2.2 IDENTIFY signal distribution paths on the R-1051B/URR Functional Block Diagram by matching each signal designation to the statement describing its distribution path, given the functional Block Diagram, a set of signal designations, and a set of statements describing signal distribution paths.

3.1.1.2.3 VERIFY the signal path of an operational R-1051B/URR Radio Receiver in accordance with Job Sheet 3.1.1.2 1J, given a job sheet, tools, equipment and materials.

REFERENCES:

NAVELEX 0967-LP-427-4010, Volume I, Technical Manual for Radio Receiver R-1051B/URR

EQUIPMENT AND MATERIALS:

1. R-1051B/URR Radio Receiver
2. AN/USM-117(V)1 Oscilloscope
3. AN/URM-25D RF Signal Generator
4. AN/USM-207 Frequency Counter
5. Tool Kit

JOB STEPS:

Precautions to be observed: Before removing or replacing any module make sure the primary power is secured by either the mode selector switch turned off or the interlock switch in the proper position. Use extreme caution when removing or replacing the modules because the pin connectors on the bottom are easily damaged.

3.1.1.2 1J

1. Preliminary operations and control settings of the R-1051B/URR Receiver:

- a. Frequency selector to 8.0 MHz.
- b. CPS switch to 000.
- c. RF Gain control fully clockwise.
- d. USB and LSB LINE LEVEL meter switches to +20dB.
- e. USB and LSB LINE LEVEL controls fully clockwise.
- f. USB and LSB PHONE LEVEL controls midrange.

2. Unscrew the six holding screws and slide the drawer out until it locks into position.

3. Locate the Translator/Synthesizer and unscrew the hold-down screws, remove module from chassis.

4. Defeat interlock 1A2S8. Place mode selector switch to the LSB mode.

NOTE: While the receiver is warming up (allow at least 5 minutes warmup time) you can set up your test equipment. Proceed to step 5.

5. Energize Test Equipment:

- a. AN/URM-25D set at 8 MHz CW, 1000 microvolts. With 50-ohm coaxial cable RG-58C/U connect RF OUT to ANT 50 OHM connector A1J23 at rear panel or receiver.
- b. AN/USM-425(V)1 adjust for proper time.
- c. AN/USM-207 set for store.

6. Using the oscilloscope, measure and record the peak to peak signal at the following test points. Furnish information requested below.

TEST POINT	P/P VOLTAGE	REF. STD./TOL.	SIGNAL SOURCE
1A2J14-A1	_____	_____	_____
1A2J12-A1	_____	_____	_____
1A2J12-A2	_____	_____	_____
1A2J12-A3	_____	_____	_____

3.1.1.2 1J

7. Measure the frequency at each of the following locations. Furnish information requested below.

TEST POINT	FREQUENCY	REF. STD./TOL.
1A2J12-A2	_____	_____
1A2J12-A3	_____	_____

PRECAUTION: Before performing the next step make sure the KCS frequency controls are still set at 000. This precaution must be observed to ensure proper alignment of cams on the bottom of the translator/synthesizer and on the receiver chassis.

8. Deenergize the receiver and replace the Translator/Synthesizer module.
9. Remove Receiver Mode Selector module from the chassis.
10. Energize the receiver. Measure and record the peak-to-peak signal at the following test points. Furnish information requested below.

TEST POINT	P/P VOLTAGE	REF. STC./TOL	SIGNAL SOURCE
1A2J16-A1	_____	_____	_____
1A2J17-A2	_____	_____	_____

11. Deenergize the receiver and replace the Receiver Mode Selector.
12. Remove the LSB IF/AF Amplifier from the chassis.
13. Energize the receiver. Measure the peak-to-peak signal at the following locations. Furnish information requested below.

TEST POINT	P/P VOLTAGE	REF. STD./TOL.	SIGNAL SOURCE
1A2J19-A2	_____	_____	_____
1A2J19-A3	_____	_____	_____

14. Deenergize the receiver and replace the LSB IF/AF Amplifier module.
15. Remove the USB IF/AF Amplifier module from the chassis.
16. Energize the receiver. Turn the mode selector switch to the CW mode of operation.

3.1.1.2 1J

17. Measure the peak-to-peak signal at the following locations. Furnish information requested below.

TEST POINT	P/P VOLTAGE	REF. STD./TOL.	SIGNAL SOURCE
1A2J18-A1	_____	_____	_____
1A2J18-A2	_____	_____	_____
1A2J18-A3	_____	_____	_____

18. Adjust RF GAIN control fully CCW. Measure the frequency at 1A2J18-A1 with the BFO control adjusted as indicated below. Record your findings in the space provided.

With the BFO control fully CW _____ kHz.

With the BFO control fully CCW _____ kHz.

After completion of this step turn the RF GAIN control CW again.

19. Turn the mode selector switch to USB. Measure the peak-to-peak signal at the following locations. Record your findings in the space provided.

TEST POINT	P/P VOLTAGE
1A2J18-A1	_____
1A2J18-A2	_____
1A2J18-A3	_____

20. Deenergize the receiver and replace the USB IF/AF Amplifier back in the equipment. Slide the drawer closed again.

NOTE: Reduce signal generator output to 5 μ v

21. The output checks for the USB and LSB IF/AF Amplifiers are done by using a headset plugged into the respective local output jack. Another output check may be accomplished by observing the LINE LEVEL METERS.

With the mode selector switch in LSB:

Do you receive good audio tone in the headset? _____

What is the LSB LINE LEVEL METER reading? _____

With the mode selector switch in USB:

Do you receive a good audio tone in the headset? _____

What is the USB LINE LEVEL METER reading? _____

3.1.1.2 1J

22. Bring your completed job sheet up for the instructor to check your work before securing the equipment.

INSTRUCTOR'S SIGNATURE

23. Secure the position and the equipment the way you found it. Then go back to your seat and complete the SELF TEST QUESTIONS.

SELF-TEST ITEMS:

1. What other mode of operation would use the same signal path as the CW mode of operation?

2. In Step 15 you were asked to make a signal check at 1A2J18-A1, why didn't you receive anything?

3. Explain how a zero beat (is obtained using the BFO control in the CW mode of operation?

4. In step 10 you were directed to turn the RF gain CCW. What is the reasons for this change?

NOTETAKING SHEET

R-1051B/URR SUBASSEMBLIES/MODULES

NOTETAKING SHEET 3.1.1.2 1N

REFERENCES:

NAVSHIPS 0967-427-4020, R-1051B/URR Technical Manual, Vol II
NAVELEX 0967-LP-970-9010, R-1051B/URR Technical Manual, Vol I
NAVELEX 0967-LP-427-5020, AN/WRC-1B Technical Manual

NOTETAKING:

This note taking sheet is provided for your to record the reference designations and names of the main subassemblies/modules for the R-1051/URR.

3.1.1.2 1N

A. R-1051B/URR

1. _____
 - a. _____
 - b. _____

2. _____
 - a. _____
 - b. _____
 - c. _____

3. _____
 - a. _____
 - b. _____
 - c. _____
 - d. _____
 - e. _____

4. _____
 - a. _____
 - b. _____
 - c. _____
 - d. _____

3.1.1.2 1N

5. _____

a. _____

b. _____

c. _____

6. _____

a. _____

b. _____

c. _____

7. _____

a. _____

b. _____

c. _____

8. _____

a. _____

b. _____

c. _____

9. _____

a. _____

b. _____

c. _____

3.1.1.2 1N

10. _____
- a. _____
 - b. _____
 - c. _____
 - d. _____

11. _____
- a. _____
 - b. _____
 - c. _____
 - d. _____

ASSIGNMENT SHEET 3.1.1.3 1A

R-1051B/URR RECEIVER AC AND DC POWER DISTRIBUTION SYSTEM

INTRODUCTION:

This assignment sheet is comprised of two parts. Part I is designed to give you practice using and reading a chassis main frame schematic diagram to obtain information.

Part II is a reading assignment on the following circuit descriptions in the R-1051B/URR Technical Manual to prepare you for the next lesson topics. Read the Frequency Standard on page 3-6, the Antenna Overload description on pages 3-10 and 3-11, the RF AMP on page 3-12, and the Translator/Synthesizer on page 3-12.

LESSON TOPIC OBJECTIVES

3.1.1.3.1 IDENTIFY the AC and DC voltage distribution paths in the R-1051B/URR by matching each voltage designation to the description of its distribution path, given the Chassis Schematic Diagram, a list of AC and DC voltages, and a list of statements describing voltage distribution paths.

STUDY QUESTIONS: Refer to Homework Handout

JOB SHEET

R-105B/URR RECEIVER AC AND DC POWER DISTRIBUTION SYSTEM

JOB SHEET NO. 3.1.1.3 1J

INTRODUCTION:

This job sheet will provide hands on experience in the chassis and main frame check out for the purpose of insuring all the voltages to and from the power supply are present. It will involve performing operational voltage checks and utilizing the chassis and main frame schematic diagram in the Student Guide.

You will also make some physical inspections prior to making any voltage checks. These experiences are necessary for a technician to determine the status of a certain power supply voltage in different modes of operation.

LESSON TOPIC LEARNING OBJECTIVES:

3.1.1.3.1 IDENTIFY The AC and DC voltage distribution paths in the R-1051B/URR by matching each voltage designation to the description of its distribution path, given the Chassis Schematic Diagram, a list of AC and DC voltages, and a list of statements describing voltage distribution paths.

3.1.1.3.2 VERIFY the operation of the AC and DC voltage distribution systems in the R-1051B/URR Receiver by measuring voltages at specified test points and comparing the results with the technical manual specifications, given the R-1051B/URR technical manual, test equipment, and a Job Sheet specifying the test points.

REFERENCES:

NAVELEX 0967-LP-427-4010, Volume 1, Technical Manual for Radio Receiver R-1051B/URR

EQUIPMENT AND MATERIALS:

1- R-1051B/URR Radio Receiver
1- AN/PSM-4
1-Tool Kit
1- MRC C-304 Q-1R card

GENERAL:

Observe all safety precautions.

3.1.1.3 1J

JOB STEPS:

- Step 1. Unscrew the six screws holding the receiver closed and slid the drawer out till it locks into position.
- Step 2. Tilt the receiver up at a 90° angle to expose the bottom for inspection.
- Step 3. Make a visual inspection of the wiring and components to insure that there are no broken or frayed wires. Also make a visual inspection of the components for broken or burnt components.
- Step 4. Defeat the interlock switch.
- Step 5. Make the following measurements and record your information below:

	TEST LOCATION		VOLTAGE	
			STANDBY	OPERATE
+110 VDC (+103 to +117 VDC)	_____	_____	_____	_____
+28 VDC (25 to +31 VDC)	_____	_____	_____	_____
-30 VDC (-28.5 to -31.5 VDC)	_____	_____	_____	_____

NOTE: USE THE CHASSIS AND MAIN FRAME SCHEMATIC DIAGRAM AND THE "E" TERMINAL LAYOUT IN THE R-1051B/URR TECHNICAL MANUAL PAGE 4-37.

- Step 6. Refer to the MRC C-304 Q-1R on the following pages and perform all the steps on the MRC. This MRC has been modified to meet the needs of the lab. It is not the actual C-304 Q-1R MRC used in the fleet.

Record your results of the MRC below:

TEST LOCATION	ORIGINAL VOLTAGE	ADJUSTED VOLTAGE
_____	_____	_____

- Step 7. Bring up your job sheet for the instructor to check your work.

Lab Instructor Signature

Secure your lab position and return all equipment and material to its proper place.

3.1.1.3 1J

SHIP SYSTEM Combat	SUBSYSTEM	MRC CODE C304 Q-1R	
SYSTEM	EQUIPMENT R-1051 B,D,E/URR	RATES 0.2	M/H 0.2
MAINTENANCE REQUIREMENT DESCRIPTION 1. Measure and adjust 20-volt regulated supply.		TOTAL M/H 0.2 ELAPSED TIME	
<p>SAFETY PRECAUTIONS</p> <ol style="list-style-type: none"> Forces afloat comply with Navy Safety Precautions for Forces Afloat, OPNAVINST 5100 series. When interlock switch is bypassed, voltages dangerous to life are present. <p>TOOLS, PARTS, MATERIAL, TEST EQUIPMENT</p> <ol style="list-style-type: none"> Multimeter, PSM-4 4" light duty screwdriver with insulated handle <p>PROCEDURE</p> <p>NOTE: Perform quarterly and when defective parts or modules have been replaced.</p> <p>Preliminary</p> <ol style="list-style-type: none"> Obtain permission from watch instructor prior to taking equipment out of service. <ol style="list-style-type: none"> Measure and Adjust 20-volt Regulator Supply. <ol style="list-style-type: none"> Turn equipment ON and set mode selector switch to STDBY. Loosen retaining screws and withdraw chassis until mechanical stops engage. Release tilt locks and tilt chassis upward 90 degrees. 			
LOCATION		DATE	

PAGE 1 OF 2

MAINTENANCE REQUIREMENT CARD (MRC)

3.1.1.3 1J

PROCEDURE (CONT)

WARNING: When interlock switch is bypassed, voltages dangerous to life are present.

- d. Defeat interlock switch;
- e. Set MCS frequency controls to 8 MCS.
- f. Set mode selector switch to AM.
- g. Set the multimeter negative lead to equipment chassis ground and positive lead to appropriate terminal below for the R-1051 B,D,E/ to tie point A2E11 (located in lower left-hand corner, to right of printed circuit board A2A8).
- h. Set multimeter to measure 20 VDC.

NOTE: Before making adjustments contact the lab instructor!

- i. Verify that multimeter indicates between 19.5 and 20.5 volts. If not, adjust potentiometer A2A8R14 for +20 VDC.
- j. Disconnect multimeter.
- k. Return chassis to horizontal position
- l. Slide chassis into case, tighten retaining screws.
- m. Return equipment to current readiness condition.

Sheet 2 of 2

MAINTENANCE REQUIREMENT CARD (MRC)

3.1.1.3 1J

SELF-TEST ITEMS

1. Failure of dial lamps 1A2A10DS3 and 1A2A10DS4 to light, when the mode selector switch is in an operate position and the lamps are known to be good, might be due to failure in the:
 - a. +20 VDC regulator circuit.
 - b. +28 VDC power supply circuitry.
 - c. +110 VDC power supply circuitry.
 - d. -30 VDC power supply circuitry.
2. When Radio Receiver R-1051B/URR is used independently, switch S9 should be in the:
 - a. DUPLEX position.
 - b. SIMPLEX position.
3. When Radio Receiver R-1051B/URR is used independently, switch S7 should be in the:
 - a. NORM position.
 - b. AUX position.
4. When relay K1 (TUNE RELAY) is energized:
 - a. Positive 20 VDC from the regulator circuit is applied to the circuits of the receiver.
 - b. Positive 28 VDC is removed from the +20 V regulator circuit.
 - c. The 115 VDC supply voltage is removed from transformer T1.
 - d. Relay K3 (XMIT-REC RELAY) is not energized.
5. If the coil of relay K2 should open the receiver would:
 - a. Receive only on those frequencies requiring HI BAND injection signals in the translation process.
 - b. Continue to operate without trouble on all frequencies.
 - c. Receive only on those frequencies requiring LO BAND injection signals in the translation process.
 - d. Lose all power as the fuses would blow when a ground was applied to K2.

3.1.1.3 1J

6. The operating voltage for VERNIER lamp 1A1DS5 is derived from:
 - a. The 110 VDC supply.
 - b. The +28 VDC supply
 - c. The +20 VDC supply.

ASSIGNMENT SHEET 3.1.1.4 1A

R-1051B/URR ANTENNA OVERLOAD RELAY AND RECEIVER
CODE GENERATOR CIRCUIT ANALYSIS

INTRODUCTION:

This assignment sheet is comprised of two parts. Part 1 is designed to give you practice using the technical manual and associated schematic diagrams to obtain information on the circuit analysis.

Part II is a reading assignment on the Receiver Mode Selector of the R-1051B/URR located on page 3-12 (paragraph 3-39), through page 3-17 (paragraph 3-54), to prepare you for the next lesson topic.

LESSON TOPIC OBJECTIVES

3.1.1.4.1 Given a list of each component part in the Receiver Code Generator circuit, a list of component part functions, and the R1051B/URR technical manual, SELECT the function of each component part in the Code Generator circuit from a list.

3.1.1.4.2 Given a listing of each signal in the Receiver Code Generator circuit, a list of statements describing signal distribution paths, and the R-1051B/URR technical manual, MATCH each signal to its distribution path description.

3.1.1.4.3 Given a list of each component part in the Antenna Overload Relay circuit, a list of component part functions, and the R-1051B/URR technical manual, SELECT the function of each component part in the Antenna Overload Relay circuit from the list.

STUDY QUESTIONS: Refer to Homework Handout

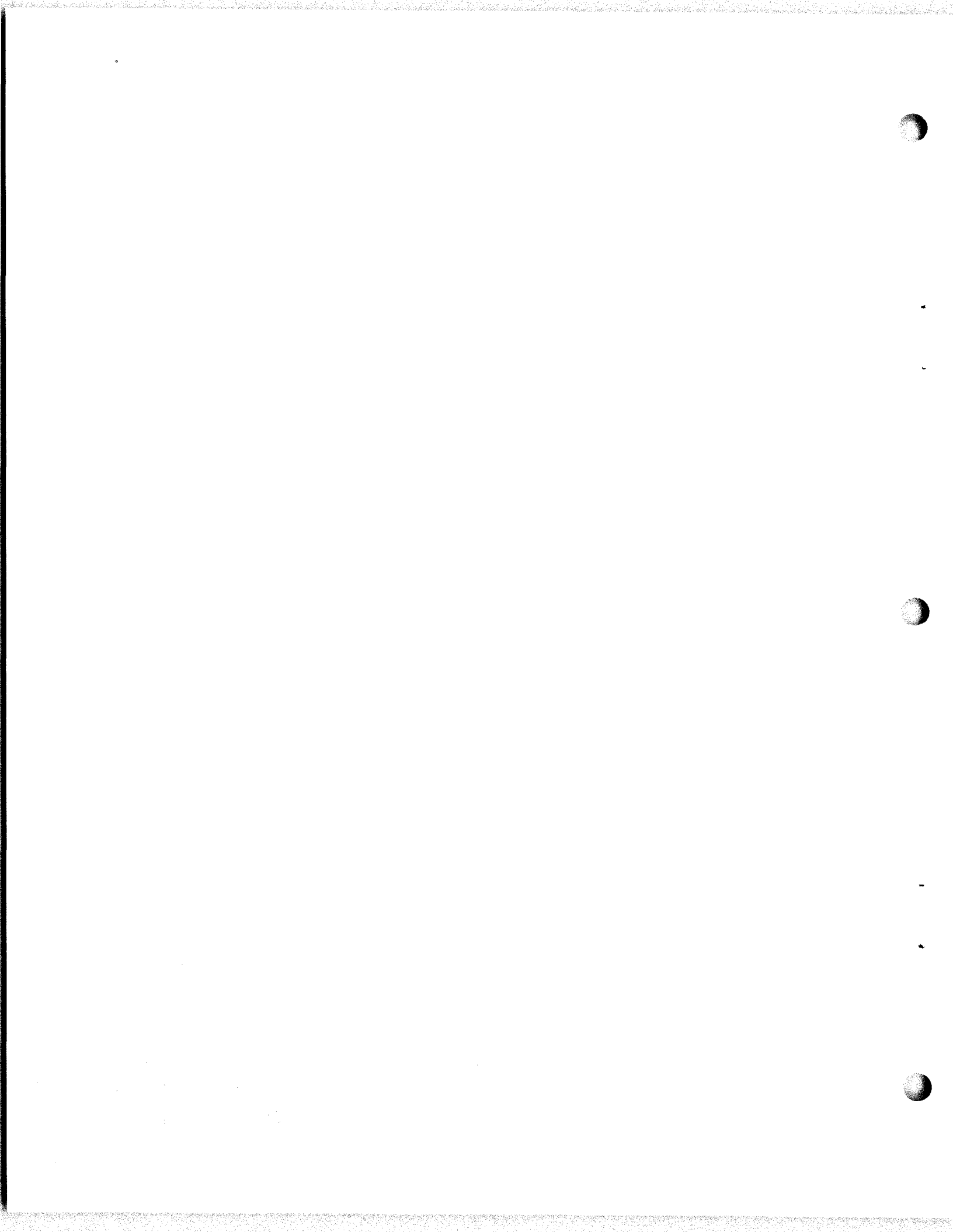

ASSIGNMENT SHEET 3.1.1.5 1A

R-1051B/URR RF AMPLIFIER ANALYSIS

INTRODUCTION

This assignment sheet is comprised of two parts. Part I is designed to give you practice in using a modified block diagram of the RF Amplifier, the chassis and main frame schematic diagram, and the functional block diagram to obtain information.

Part II is a reading assignment on the circuit description in the R-1051B/URR Technical Manual to prepare you for the next lesson topic. Read the description of the Frequency Standard on page 6 (paragraph 3-19). Also the description of the Translator/Synthesizer on pages 6, 7, and 8 (paragraph 3.20 through 3-30).

LESSON TOPIC OBJECTIVES

3.1.1.5.1 Given a list of each component part in the A2A4 Radio Frequency Amplifier Assembly, a list of component part functions, and the R-1051B/URR technical manual, SELECT the function of each component part in the A2A4 Assembly from the list.

3.1.1.5.2 Given a list of statements describing signal distribution paths, and the R-1051B/URR technical manual, SELECT the statement describing the output signal path from the A2A4 Radio Frequency Amplifier Assembly.

3.1.1.5.3 Given a list of each designated test point in the A2A4 Radio Frequency Amplifier Assembly, a set of waveforms with frequency and amplitude indicated, and the R-1051B/URR technical manual, MATCH each test point to the waveform present at the test point.

STUDY QUESTIONS: Refer to Homework Handout.



JOB SHEET

R-1051B/URR RF AMPLIFIER CHECKOUT

Job Sheet 3.1.1.5 1J

INTRODUCTION

This job sheet will provide hands on experience with the RF Amplifier. It will involve performing operational voltage checks to determine if the RF Amplifier is working properly.

You will also determine if the turret has selected the correct output strip (section). Also make other visual inspections of the module.

LESSON TOPIC LEARNING OBJECTIVES:

3.1.1.5.4 VERIFY the operational status of the 1A24 Radio Frequency Amplifier in the R-1051B/URR Receiver by monitoring waveforms and measuring voltages at specified test points and comparing the results with technical manual specifications, given a R-1051B/URR technical manual, test equipment, and a Job Sheet with procedures and test points specified.

REFERENCES:

NAVELEX 0967-427-4010 R-1051B/URR Technical Manual Vol. 1
NAVSHIPS 0967-970-9050 Maintenance Standards Book for R-1051B/URR Receiver

EQUIPMENT

- 1- R-1051B/URR Radio Receiver
- 1- AN/URM-25 RF Signal Generator
- 1- AN/USM 117 Oscilloscope
- 1- Tool kit

General

Observe all safety precautions.

Step 1. Unscrew the six screws holding the receiver closed and slide the drawer out until it locks into position.

Step 2. Your reference for the turret rotation check will be Table 1.

- a. Set the MODE SELECTOR TO LSB, and place the MHz controls on 2 MHz. The turret assembly should have rotated to the proper input, intersection, output tank assemblies.
- b. For the 2 MHz dialed up, you should have found that it stopped with A2 showing in the round hole in the top of the cover on the RF Amp.

3.1.1.5 1J

- c. Repeat steps 2a and 2b for each Megacycle 03 through 29. The turret should stop each at the correct section giving you the correct A# in the window for that frequency dialed.

Step 3. Check the RF Amplifier gain as directed in the R-1051B/URR technical manual, paragraphs 4-75, 4-76, 4-77 and 4-78 on page 4-27 utilizing the frequencies listed below.

NOTE: In paragraph 4-78 on page 4-27 it tells you to use 1000 mV for your output from the AN/URM 25. It should have read 1000 microvolts. It also tells you to use a RF voltmeter for the checks but for the school's lab you will use an AN/USM-117 Oscope in its place. Remember this is for school only. In the fleet use the RF voltmeter as called for.

	p/p	RMS	Av
a. 3.101 MHz.	_____ mV	_____	_____
b. 4.222 MHz.	_____ mV	_____	_____
c. 6.333 MHz.	_____ mV	_____	_____
d. 8.444 MHz.	_____ mV	_____	_____
e. 10.555 MHz.	_____ mV	_____	_____
f. 12.666 MHz.	_____ mV	_____	_____

Step 4. You have measured the peak to peak signal strength. Now you will convert these readings to an RMS value. Remember to convert the p/p signal to RMS, multiply the peak value by .707. Record your answers in the above chart.

Step 5. You now know the p/p values and also the RMS values. Still using the chart above you will compute the average/dB values. Here is the formula:

$$A_v = \frac{E_{out\ RMS}}{E_{in\ RMS}} \quad dB = 20 \text{ Log } A_v$$

Log 10=1
 Log 50=1.7
 Log 100=2
 Log 150=2.2
 Log 200=2.3

Step 6. Have the instructor verify your work.

 Instructor Initial

Step 7. Secure your lab position and return all equipment and materials to their proper place.

3.1.1.5 1J

DIGITAL TUNING OF THE RF AMPLIFIER

FREQ. MC	INPUT	INTERSTAGE	OUTPUT
2	A20	A25	A2
3	A21	A26	A3
4	A22	A27	A4
5	A23	A28	A5
6	A24	A29	A6
7	A25	A2	A7
8	A26	A3	A8
9	A27	A4	A9
10	A28	A5	A10
11	A29	A6	A11
12	A2	A7	A12
13	A3	A8	A13
14	A4	A9	A14
15	A5	A10	A15
16	A6	A11	A16
17	A7	A12	A17
18	A8	A13	A18
19	A9	A14	A19
20	A10	A15	A20
21	A11	A16	A21
22	A12	A17	A22
23	A13	A18	A23
24	A14	A19	A24
25	A15	A20	A25
26	A16	A21	A26
27	A17	A22	A27
28	A18	A23	A28
29	A19	A24	A29

Table 1

ASSIGNMENT SHEET 3.1.1.6 1A

R-1051B/URR FREQUENCY STANDARD AND TRANSLATOR/SYNTHESIZER ANALYSIS

INTRODUCTION:

This assignment sheet is comprised of two parts. Part I is designed to give you practice using and reading the Simplified Block Diagram of the R-1051B/URR, the Chassis Main Frame Schematic Diagram, the Frequency Standard Block Diagram, and the Frequency Translation Block Diagram to obtain information.

Part II is a reading assignment on the circuit description in the R-1051B/URR Technical Manual to prepare you for the next lesson topic. Read the Receiver Mode Selector description on pages 3-12, 3-13, 3-14, and 3-17.

LESSON TOPIC OBJECTIVES:

3.1.1.6.1 Given a block diagram of the A2A5 Frequency Standard Assembly, and the R-1051B/URR technical manual, SELECT the function of each component part in the 1A2A5 Assembly from the list.

3.1.1.6.2 IDENTIFY the function of each output signal frequency from the 1A2A5 Frequency Standard Assembly by matching the frequency to its functions, given a list of each output signal from the assembly, a list of statements describing the function performed by each output frequency, and the R-1051B/URR technical manual.

3.1.1.6.3 IDENTIFY the Input/Output signal characteristics of the 1A2A5 Frequency Standard by matching waveforms to signal designations, give a list of 1A2A5 unit input/output signal designations, a set of waveforms with amplitude and frequency indicated, and the R-1051B/URR technical manual.

3.1.1.6.4 Given a list of statements describing signal distribution paths, and the R-1051B/URR technical manual, IDENTIFY each signal distribution path from the 1A2A5 Frequency Standard by matching each signal path description to the signal distributed.

3.1.1.6.5 Adjust the 1A2A5 Frequency Standard in the R-1051B/URR Receiver in accordance with Maintenance Requirement Care C-304 M-1R, given the MRC, tools, test equipment and the R-1051B/URR technical manual.

3.1.1.6.7 IDENTIFY the function of each output signal from each subassembly in the 1A2A6 Translator/Synthesizer Assembly by matching output signal descriptions to function, given descriptions of each output signal from the 1A2A6 assembly, a list of functions, and the R-1051B/URR technical manual.

3.1.1.6.8 COMPUTE the output frequency from the 1A2A6A4 100 CPS Synthesizer Subassembly, given the MCS, KCS, and CPS dial settings and the R-1051B/URR technical manual.

3.1.1.6 1A

3.1.1.6.9 COMPUTE the output frequency from the 1A2A6A3 1 and 10 KCS Subassembly, given the MCS, KCS, and CPS dial settings, and the R-1051B/URR technical manual.

3.1.1.6.10 COMPUTE the output frequency from the 1A2A6A2 100 KCS Subassembly, given the MCS, KCS and CPS dial settings, and the R-1051B/URR technical manual.

3.1.1.6.11 COMPUTE the output frequency from the 1A2A6A4 MC Synthesizer Subassembly, given the MCS, KCS, and CPS dial settings, and the R-1051B/URR technical manual.

STUDY QUESTIONS: Refer to Homework Handout



JOB SHEET

R-1051B/URR FREQUENCY STANDARD

JOB SHEET NO. 3.1.1.6 1J

INTRODUCTION:

This job sheet will provide hands on experience in the Frequency Standard check out for the purpose of insring that all the signals out of the Frequency Standard are present. It will involve performing operational signal checks and frequency checks by using the Student Guide and Technical Manual.

LESSON TOPIC LEARNING OBJECTIVES:

3.1.1.6.5 ADJUST the 1A2A5 Frequency Standard in the R-1051B/URR Receiver in accordance with Maintenance Requirement Card C-304 M-1R, given the tools, test equipment and the R-1051B/URR Technical Manual.

REFERENCE:

NAVELEX 0967LP-427-4010 Volume 1 R-1051B/URR Technical Manual

EQUIPMENT and MATERIALS:

1. R-1051B/URR Radio Receiver (1)
2. Frequency Counter (1)
3. Single Trace Oscope (1)
4. MRC C-304 M-1R card

GENERAL:

Observe all safety precautions.

JOB STEPS:

- Step 1. Unscrew the six screws holding the receiver closed and slide the drawer out till it locks into position.
- Step 2. Loosen the four retaining screws on the Translator/Synthesizer down and remove the module from the chassis. Place the module on its side on the workbench.
- Step 3. Defeat the interlock switch.
- Step 4. Set up oscilloscope with a trace on the screen. Turn the frequency counter on.

3.1.1.6 1J

NOTE: Use the R-1051B/URR Simplified Block Diagram and the Main Chassis, Top View Connector Pin Location Diagram in the R-1051B/URR Technical Manual page 4-38.

Step 5. Make the following measurements using the frequency counter and oscilloscope, and record your information below:

	TEST LOCATION	FREQUENCY	VOLTAGE (P/P)
5 MHz (+ 0.5 Hz)	_____	_____	<u> </u> / <u> </u> minimal/actual
500 kHz (+ 0.1 Hz)	_____	_____	<u> </u> / <u> </u>
1 MHz	_____	_____	<u> </u> / <u> </u>
Ext 5 MHz in	_____	_____	<u> </u> / <u> </u>
10 MHz	_____	_____	<u> </u> / <u> </u>

Step 6. Refer to the MRC C-304 M-1R on the following pages and perform all the steps on the MRC. This MRC has been modified to meet the needs of the lab. It is not the actual C-304 M-1R used in the fleet.

Did your comparator lamp DS1 give you the indications asked for by the MRC C-304 M-1R?

yes/no

If your answer was no, would the frequency standard adjustment display any noticeable change in the way it glowed?

yes/no

Step 7. Bring up your job sheet for the instructor to check your work.

Lab Instructor Signature

Secure your lab position and return all equipment and materials to its proper place.

SHIP SYSTEM	SUBSYSTEM	MRC CODE C-304 M-1R	
SYSTEM	EQUIPMENT R-1051, B, D, E/URR	RATES ETN3	M/H 0.3
MAINTENANCE REQUIREMENT DESCRIPTION 1. Test and adjust frequency standard A2A5.		TOTAL M/H 0.3 ELAPSED TIME 0.3	
<p>SAFETY PRECAUTIONS</p> <ol style="list-style-type: none"> Forces afloat comply with Navy Safety Precautions for Forces Afloat, OPNAVINST 5100 series. When interlock switch is bypassed, voltages dangerous to life are present. <p>TOOLS, PARTS, MATERIALS, TEST EQUIPMENT</p> <ol style="list-style-type: none"> Frequency Standard, AN/URQ-10 or equivalent Compartment clock or watch with sweep second hand Tool kit <p>PROCEDURE</p> <p>NOTE 1: Various type frequency standards (A2A5) modules have different 5 MHz OSC source switch position markings. Early versions are marked COMP-INT-EXT, later versions marked INT/COMP-EXT NORMAL-EXT (OVEN STBY). Tests and adjustments are performed in COMP or (INT/COMP) positions.</p> <p>Preliminary</p> <ol style="list-style-type: none"> Ensure 5 MHz Frequency Standard A2A5 module oscillator source Switch is set to either COMP, INT/COMP, or EXT (OVEN STBY) position. This will energize the Internal Oscillator oven heater and allow temperature to stabilize prior to commencing test. 			
LOCATION		DATE January 1978	

PAGE 1 OF 2

PROCEDURE (CONT)

1. Test and Adjust Frequency Standard A2A5.

- a. Connect 5MHz signal from external frequency standard to EXT 5mc IN jack, if central frequency distributing system is not utilized.

WARNING: When interlock switch is bypassed, voltage dangerous to life are present.

- b. Loosen retaining screws and withdraw equipment chassis containing frequency standard; bypass interlock switch.
- c. Set 5MHz OSC source switch (located on top of A2A5 module) to COMP or (INT/COMP).
- d. Verify that comparator lamp DS1 is flashing at some visual rate. If flashing is not observed do not adjust or continue procedural steps. Perform corrective maintenance.
- e. Measure time with clock or watch from when the comparator lamp DS1 just begins to increase brilliance until DS1 again just begins to increase brilliance. The minimum lamp cycle time should be:
 - (1) 5 seconds for installations utilizing central frequency distribution systems.
 - (2) 10 seconds for installations not utilizing central frequency distribution systems.

CAUTION: When adjusting FREQ ADJUST (FINE FREQUENCY ADJUST) always turn slowly, do not overadjust. Less than one-quarter turn will correct most drift. Use very little pressure to prevent damage to capacitor.

NOTE 4: For Frequency standards that have both FINE and COARSE FREQUENCY ADJUST controls that are accessible on dust cover. If FREQ ADJUST (FINE FREQUENCY ADJUST) is at the end stop, reset this adjustment 13 turns from end stop; adjust COURSE ADJ for slowest rate of change of brilliance.

- f. If adjustment is necessary, adjust FREQ ADJUST (FINE FREQUENCY ADJUST) for minimum rate of change of brilliance (DS1) noted in step 1.e. If screwdriver slot is not accessible on top of frequency standard, remove dust cover. Repeat adjustment several times to obtain slowest rate of change.
- g. Wait 5 minutes and repeat step 1.e.
- h. Set 5MHz source switch to:
 - (1) EXT or (EXT NORMAL) on installations utilizing central frequency distribution systems.
- i. If step 1.h. (2) was performed, disconnect external frequency standart from EXT SMC IN jack.
- j. Reinstall dust cover on frequency standard, if applicable.
- k. Return equipment to normal readiness position.

3.1.1.6 1J

SELF-TEST ITEMS

1. In the functional checkout of the frequency standard subassembly, the frequency setting knobs must be set to a frequency of 2 MHz or above because:

a. The line voltage will not be applied to the frequency standard subassembly if 0 or 1 MHz is set up.

b. Plus 20 VDC will not be applied to the frequency standard subassembly if 0 or 1 MHz is set up.

c. The 10 MC signal from the frequency standard subassembly is short circuited if 0 or 1 MHz is set up.

d. None of the above is correct. It is not necessary to set the frequency setting knobs to any particular frequency.

2. In the functional checkout of the frequency standard subassembly it is necessary to check reception in the 5 and 10 MHz bands because:

a. These frequencies ensure that both the HI and LO injection are being developed.

b. These frequencies have time signal stations on them and the operator will be sure of hearing a signal.

c. This ensures that the 1 MHz and 10 MHz from the frequency standard subassembly is making good contact in the coaxial fittings between the subassembly and the main frame.

d. This ensures that the 1 MHz signal from the frequency standard subassembly is being applied to the 100 kHz synthesizer.

ASSIGNMENT SHEET 3.1.1.7 1A

R-1051B/URR RECEIVER MODE SELECTOR CIRCUIT ANALYSIS

INTRODUCTION:

This Assignment Sheet is comprised of three parts. Part I is designed to give you practice using the technical manual and associated schematic diagrams to obtain information on the circuit analysis.

Part II is a color coding assignment on the IF/AF amplifier schematic diagram located in the schematic pack, Vol 3. Part II will also aid you in seeing the overall picture of the module. With the colored schematic you can see how each section works for the other.

Part III is a reading assignment on the IF/Audio Amplifier of the R-1051B/URR located on page 3-17, Par. 3-55, through page 3-29, Par. 3-80 to prepare you for the next lesson topic.

LESSON TOPIC LEARNING OBJECTIVES

3.1.1.7.1 Given a list of component part functions in the A2A1 Receiver Mode Selector assembly, and the R-1051B/URR technical manual, SELECT the function performed by each component part in the A2A1 assembly.

3.1.1.7.2 Given a list of each output signal from the A2A1 Receiver Mode Selector Assembly, a list of statements describing signal distribution paths, and the R-1051B/URR technical manual, MATCH each output signal to its distribution path.

3.1.1.7.3 Given a list of each control signal into the A2A1 Receiver Mode Selector Assembly, a list of statements describing signal distribution paths, and the R-1051B/URR technical manual, MATCH each input control signal to its distribution path.

STUDY QUESTIONS: Refer to Homework Handout

ASSIGNMENT SHEET 3.1.1.8 1A

R-1051B/URR IF/AUDIO AMPLIFIER CIRCUIT ANALYSIS

INTRODUCTION:

This assignment sheet is comprised of three parts. Part I is designed to give you practice using the technical manual and the functional block diagram or the IF/Audio amplifier diagram to find information.

LESSON TOPIC OBJECTIVE(S):

3.1.1.8.1 IDENTIFY each signal that can be processed by the 1A2A2 and 1A2A3 IF/Audio Amplifier Assemblies by matching each assembly designation to each signal that can be processed by that assembly, given the R-1051B/URR technical manual, and a list of signals that can be received by the R-1051B/URR.

3.1.1.8.2 IDENTIFY the signal distribution path for each signal from the 1A2A2 and 1A2A3 IF/Audio Amplifier Assemblies by matching each signal to its distribution paths, given a list of signals from the 1A2A2 and 1A2A3 assemblies, a list of statements describing the signal distribution paths, and the R-1051B/URR technical manual.

3.1.1.8.3 Given a list of component part functions, and a list of each component part in the 1A2A2 and 1A2A3 IF/Audio Amplifier Assemblies, and the R-1051B/URR technical manual, IDENTIFY the function of each component in the IF/Audio Amplifier assemblies by selecting its function from the list.

STUDY QUESTIONS: Refer to Homework Handout

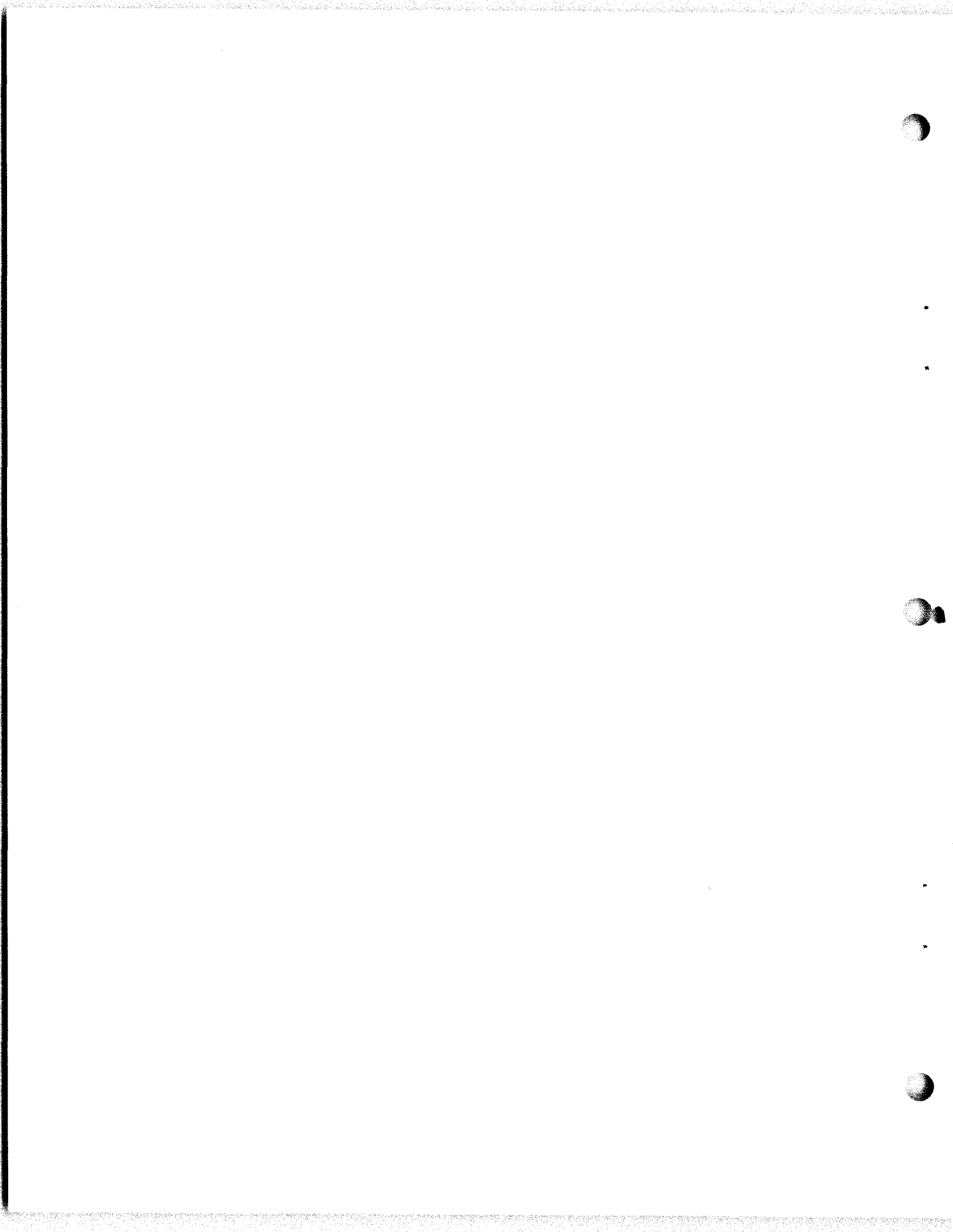

THE STEP TYPE AGC SYSTEM

INTRODUCTION:

The step type of AGC system is new. Older methods of AGC, such as those used in AM receivers, are almost completely useless when used in single sideband reception.

This information sheet discusses the basic concept of deriving the AGC voltage and its application to a transistor amplifier stage to control gain.

REFERENCES:

NAVSHIPS 94841(A), Technical Manual for Radio Receiver R-1051/URR, page 4-5, paragraph 4-25; page 4-30, paragraphs 4-131 through 4-142, page 4-34; pages 4-109, 4-110, Figure 4-54; pages 5-17, 5-18, Figure 5-3.

INFORMATION

Conventional AGC systems used in AM receivers are almost completely useless when used in single sideband reception. The problem is that the usual AGC system derives its control voltage from the carrier that is transmitted along with the information signal. Since in SSB transmission, no carrier is present to establish a signal strength level, the AGC system must establish its control voltage from the information contained in the one sideband. This information varies greatly in amplitude and, with normal voice operation, is intermittent. A second problem is intermodulation distortion when the bias of amplifiers is increased in order to control their gain.

A third problem is encountered with independent sideband operation. In this mode of operation, both sidebands are transmitted with different information on each one. Since two intermediate frequency channels are required for demodulation, two AGC signals are derived. The two sidebands involved may vary greatly in amplitude, so a way must be found to apply these two AGC control voltages to the receiver front end.

3.1.1.8 II

The basic approach to the problem of constructing such an AGC system is to reduce, or entirely eliminate, the interdependency of discharge and hang time. A sample of the received signal is taken from the IF path and applied to a tuned amplifier. Two outputs are taken from the amplifier, identical in frequency and character, but differing in amplitude by twenty percent. The larger of the two signals (E_1) is applied to a timing detector having a fast rise time and a definite prescribed discharge time. The lower amplitude signal (E_2) is applied to a similar detector having a fast rise time and an extremely long discharge time. The two DC output voltages of these detectors are compared in a switch. As long as E_1 remains above E_2 , the AGC output voltage will remain equal to E_2 and thus, be relatively flat even in the absence of input signal. Depending upon the pre-established discharge time constant of the timing detector, voltage E_1 will at some time drop to a value less than E_2 , at which time the comparison switch will discharge both detector outputs to ground, thus causing the AGC voltage to drop to near zero. If, during the process, new signal information is received in the IF amplifier strip, this circuit rapidly resets itself on the new information and repeats the above described process. Figure 1 illustrates the action that takes place.

Aside from the problem of derivation of an adequate control voltage, there is yet another problem; the generation of intermodulation distortion in the amplifiers whose gains are being controlled. For optimum AGC operation, the input function bias of the semiconductor amplifiers is reduced, hence, it would seem that the ability of the stage to handle the increased signals, without generation of an appreciable amount of intermodulation distortion, is somewhat limited.

Intermodulation distortion is the creation of distortion products based on the sum and difference frequency of harmonics of the desired signals. If signals of 1000 kHz and 1001 kHz were presented to a nonlinear element having second and third order curvature, the difference frequency of 1 kHz could remodulate each frequency to develop distortion products at 999 kHz and 1002 kHz. Since all of these signals are within the passband, selectivity is of no help. Reducing emitter current to control gain is accompanied by a reduction in power handling capability. As signal input is increased and the gain of the transistor is reduced, distortion tends to rise. The best solution to the problem is to preserve the linearity of the stage and to leave intact dynamic range of the amplifier, by finding other methods of controlling gain.

Removal of the by-pass capacitor from across the emitter resistor of a transistor amplifier results in decreased gain due to negative current feedback. Since the linear range of the amplifier is increased distortion is reduced with increase of signal. A transistor can be used as a variable resistance which is a function of a DC current change. This DC controlled impedance can be connected in series with the emitter by-pass capacitor to effectively control the gain by varying the degree of feedback.

3.1.1.8 1I

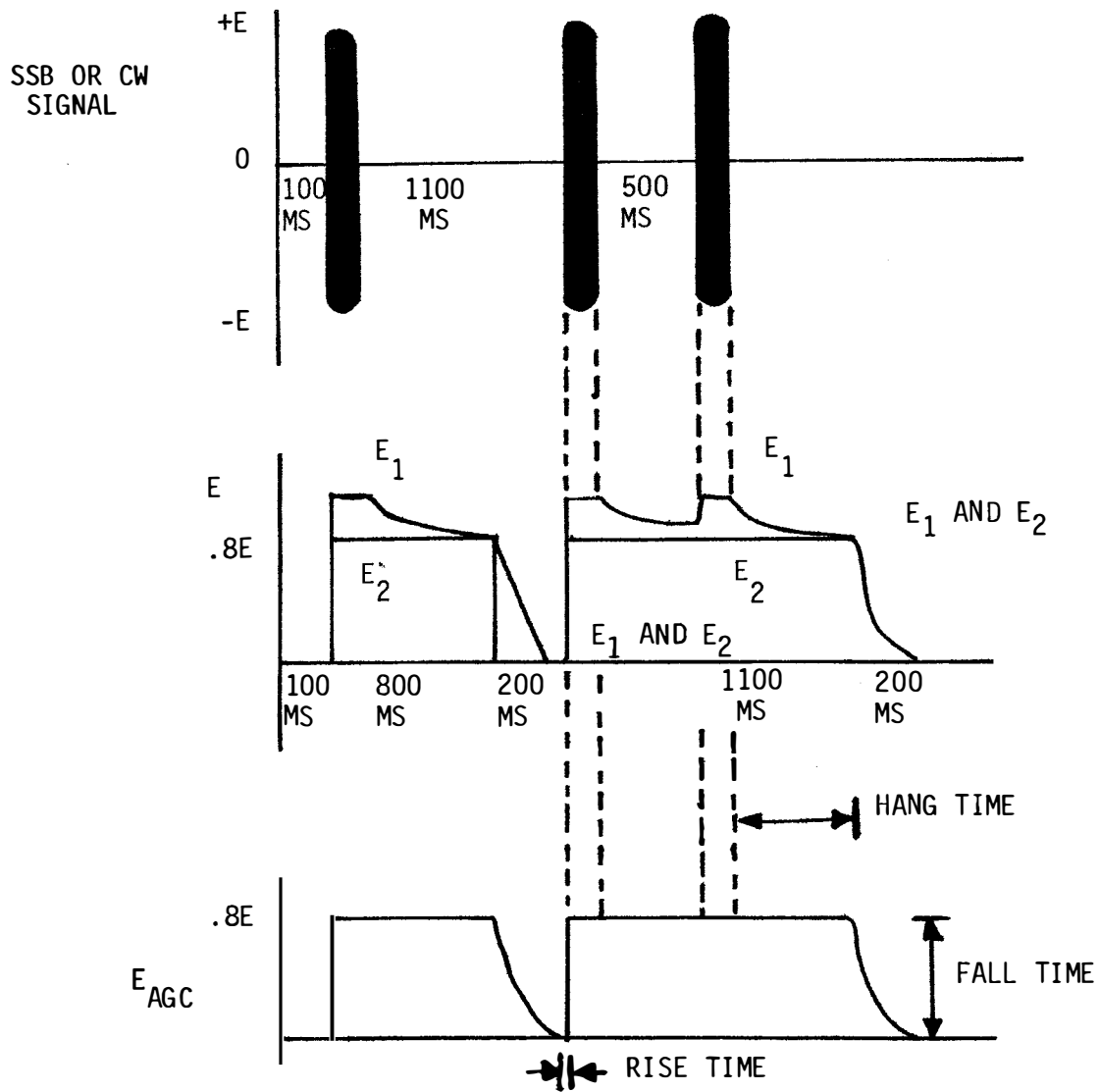

FIGURE 1
AGC RESPONSE TO SSB OR CW SIGNAL

3.1.1.8 1I (cont'd)

In independent sideband transmission, where each sideband is carrying different intelligence, one sideband may be received at a much different level than the other due to fading. Since each IF channel is developing an AGC voltage, a choice must be made as to which shall control the RF or front end gain. A simple gating method may be used to insure that the higher of the two control signals will govern the gain of the system.

Figure 2 presents a block diagram of the AGC system.

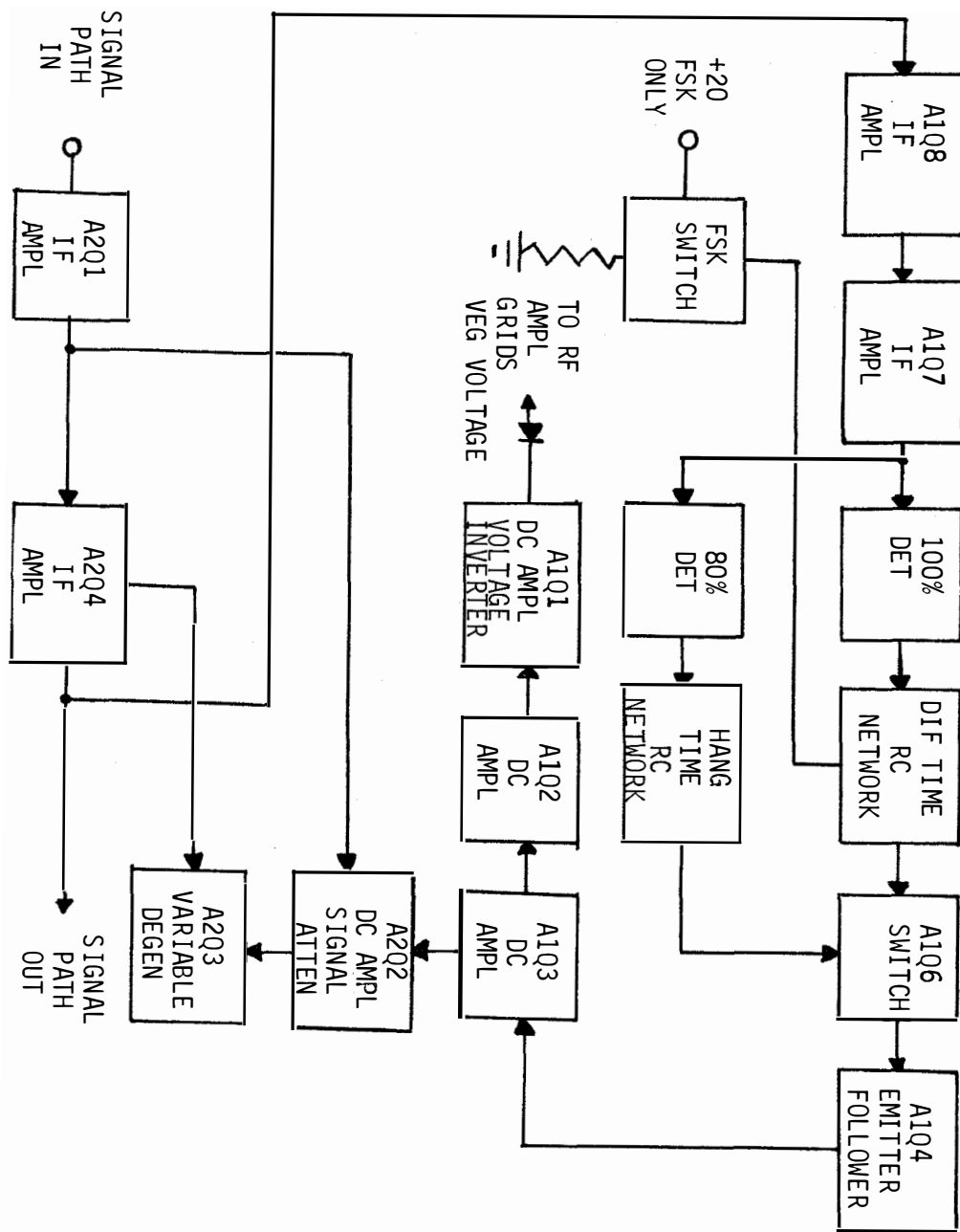

FIGURE 2

AGC SYSTEM BLOCK DIAGRAM

AGC CIRCUIT DESCRIPTION

INTRODUCTION:

Since the receiver IF, AGC and audio subassembly has, as the name suggests, several functions, it was deemed best to discuss the AGC circuitry separate from that of the IF and audio portions.

The student will find that he can completely divorce the AGC action from the rest of the subassembly circuitry. Since the AGC function is rather complicated, the student will appreciate this separation of circuit description.

REFERENCES:

NAVSHIPS 94841(A), Technical Manual for Radio Receiver, R-1051/URR, page 4-30, paragraphs 4-131 through 4-142, page 4-34; pages 5-17, 5-18, Figure 5-3.

INFORMATION:

After amplification in the first two stages of the regular signal IF amplifier, the signal is further amplified by two IF stages associated only with the AGC system. The four stages are A2Q1, A2Q4, A1Q8, and A1Q7 in that order.

Two signals of different amplitude are taken from the secondary of transformer A1T1. The 100-percent signal is rectified by diode A1CR5 and the resulting DC is applied to capacitor A1C5 and resistor A1R19, a time constant circuit having a fast rise time and a definite prescribed discharge time. This signal is also connected to the base of switch transistor A1Q6. To 80-percent signal from transformer A1T1 is rectified by diode A1CR4 and applied to the emitter of A1Q6 and to capacitor A1C3. Capacitor A1C3, and normal leakage resistance due to circuitry (this will be high), may be considered a time constant having a fast rise time and an extremely long discharge time. As long as the voltage on time constant circuit A1C5-A1R19 remains above the voltage on time constant circuit A1C3, the AGC voltage remains equal to the voltage on A1C3. At such time, as the voltage on A1C5-A1R19 drops below that on A1C3, transistor switch A1Q6 conducts heavily. When A1Q6 saturates, all three elements drop very close to ground potential. This action grounds both time constant circuits and they start to discharge rapidly. If, during this time, new information is received in the IF amplifier, the system resets itself based on the amplitude of the new information. Faster action is desired in the FSK mode of operation. In this mode, less fading can be tolerated so the step cycle must be speeded up. Transistor switch A1Q5 operates only in the FSK mode of transmission. Since this transistor is an NPN, a positive potential on its base causes it to saturate. When saturation takes place, all elements of the transistor drop to very near ground potential. This effectively grounds resistor A1R17 to place it in parallel with resistor A1R19, thus, halving the RC time constant of A1C5-A1R19. The control voltage of +20 DC is obtained from the mode selector switch. The high input impedance of emitter follower A1Q4 is used to couple the AGC circuit to DC amplifier A1Q3. The AGC

INFORMATION SHEET 3.1.1.8 2I

voltage for the IF amplifiers is taken from the emitter to this amplifier and fed to the base of transistor A2Q2. Diode A2CR1 acts to stabilize the base bias of A2Q2 for temperature variations. Capacitors A2C4 and A2C7 are in series. These two capacitors couple transformer A2T1 to the base of IF amplifier A2Q4. The effective impedance of the coupling capacitors is negligible at the intermediate frequency and can be disregarded. Transistor A2Q2 may be considered as a variable resistor whose resistance is controlled by the AGC voltage. The transistor, as a variable resistance is connected from the junction of the two capacitors to ground. This variable resistor A2R5, forms a voltage divider form of variable attenuator. Figure 1 shows a simplified circuit. The capacitors have been disregarded, since their impedance is negligible.

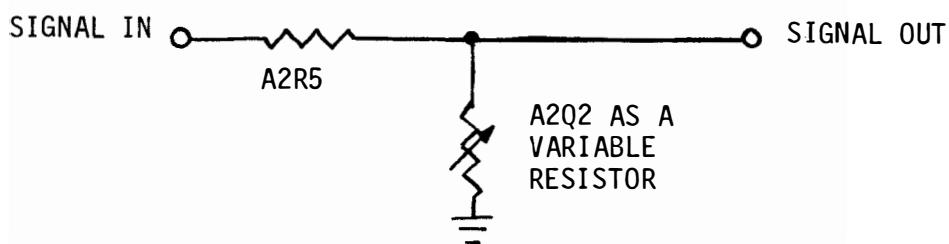

FIGURE 1

Voltage Divider, Simplified Circuit

Further control of the IF amplifier gain is achieved by transistor A2Q3 and associated circuitry. A small amount of gain is realized in transistor Q2Q2. The amplified DC is fed to the base of A2Q3. In this transistor configuration, the collector is DC isolated.

3.1.1.8 2I (cont'd)

Transistor A2Q3 can be considered as a variable resistor, under control of the AGC voltage, and in series with capacitor A2C9. The capacitor is the by-pass capacitor for emitter-bias resistor A2R12 of IF amplifier stage A2Q4. If A2Q4 had no by-pass capacitor, its gain would be considerably reduced due to negative current feedback. A2Q3, as a variable resistance in series with its by-pass capacitor, controls the gain of stage A2Q4 by effectively varying the negative current feedback. Figure 2 is a simplified schematic of this circuit.

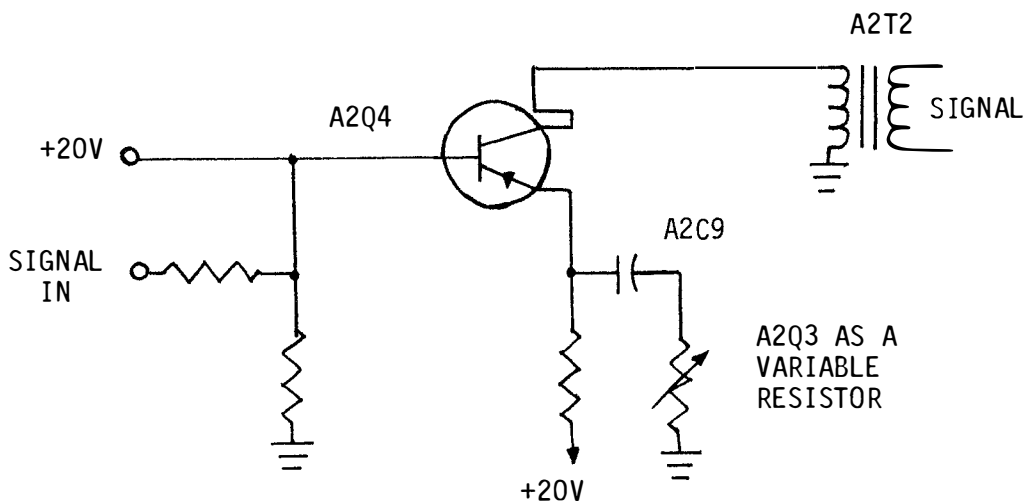

FIGURE 2

Amplifier Gain Control, Simplified Schematic

A second output from DC amplifier A1Q3 is taken from the collector and fed to the base of A1Q2, also a DC amplifier. This stage uses two diodes, A1CR2 and A1CR3, whose forward conduction stabilizes the emitter bias and sets the threshold at which AGC action begins in the RF Amplifier. The output of DC amplifier A1Q2 drives the base of amplifier A1Q1. This stage has -30 volts as its collector voltage. The output is a negative AGC voltage which is fed to the RF amplifier to control the gain of the two vacuum tubes used in this subassembly. This stage can swing slightly positive at low signal inputs, therefore, diode A1CR1 is used to prevent any application of this small DC voltage to the grids of the tubes.

3.1.1.8 2I (cont'd)

Diode A1CR1, taken together with the identical diode in the second IF amplifier AGC circuit, performs another function when both AGC voltages are present in the ISB mode of operation. Figure 3 shows the two AGC voltages applied through the diodes to the grids of the RF amplifier tubes. If it is assumed that AGC No. 1 is -1V at a given time and that AGC No. 2 is -2V at this same time, then the -2V will back bias the diode associated with AGC No. 1; therefore, AGC No. 2 takes over control of the RF amplifier until such time as AGC No. 1 becomes the higher of the two control voltages. When this happens, the diode associated with AGC No. 2 becomes back biased and AGC No. 1 takes over.

Two variable control are used to set the AGC voltages. Resistor A1R25 is used to set the overall AGC voltage as required by the IF amplifier and resistor A1R6 is used to set the required AGC voltage for the RF amplifier.

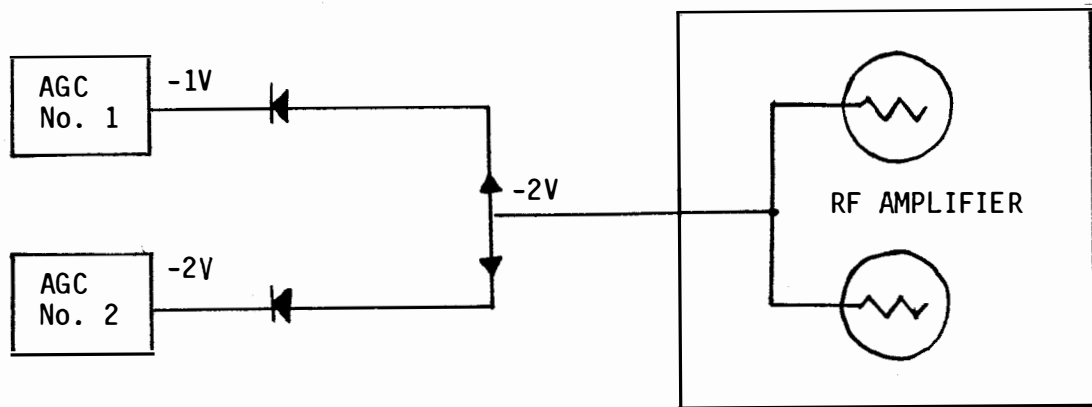

FIGURE 3
Applied AGC Voltages

JOB SHEET

R-1051B/URR RECEIVER SENSITIVITY ANALYSIS

JOB SHEET NO. 3.1.1.8 1J

INTRODUCTION

This job sheet will provide hands on experience on the testing of the receiver's sensitivity. This will also aid the student in understanding what receiver sensitivity is and to check the frequency accuracy.

You will also make some physical inspections prior to making any checks. These experiences are necessary for a technician to determine the status of that receiver.

LESSON TOPIC LEARNING OBJECTIVE(S):

3.1.1.8.4 VERIFY the operational status of the A2A2 and A2A3 IF/Audio Amplifier Assemblies in the R-1051B/URR Receiver by monitoring waveforms and measuring voltages at specified test points and comparing the results with the technical manual, test equipment, and a Job Sheet with procedures and test points specified.

REFERENCES:

NAVELEX 0967-LP-427-4010 R-1051B/URR Technical Manual, Volume 1

EQUIPMENT AND MATERIALS:

1. R-1051B/URR Radio Receiver (1)
2. RF Signal Generator, AN/URM-25 (1)
3. Electronic Counter, AN/USM-207 (1)
4. Maintenance Requirement Card (MRC) C-304, Q-2 (1)
5. Tool Kit (1)

GENERAL:

Observe all safety precautions

JOB STEPS:

- Step 1. Refer to the MRC C-304 Q-2 on the following pages and perform all the steps on the MRC. This MRC has been modified to meet the needs of the lab. It is not the actual C-304 Q-2 MRC used in the fleet.

3.1.1.8 1J

Step 2. Do the portion under Measure Receiver Sensitivity and complete the chart listed below, using the LSB mode of operation.

Frequency	Signal Generator Output	Frequency	Signal Generator Chart
3.101 MHz	_____	17.010 MHz.	_____
7.555 MHz	_____	20.010 MHz.	_____
10.898 MHz.	_____	23.010 MHz.	_____

Step 3. Still under the Measure Receiver Sensitivity complete this chart using the USB mode of operation.

Frequency	Signal Generator Output	Frequency	Signal Generator Chart
6.444 MHz.	_____	11.989 MHz.	_____
8.666 MHz.	_____	13.010 MHz.	_____
9.777 MHz.	_____	15.010 MHz.	_____

Step 4. Refer to the portion under Test Frequency Locking Action on the MRC C-304 Q-2 and perform all the steps listed.

Step 5. Bring up your job sheet for the instructor to check your work.

Lab Instructor's Signature

Secure your lab position and return all equipment and materials to their proper place.

SHIP SYSTEM		SUBSYSTEM		MRC CODE	
				C-304 Q-2	
SYSTEM		EQUIPMENT		RATES	M/H
		AN/WRC-1, 1B Radio Set R-1051, 1051B/URR Radio Receiver		ETN3	0.8
MAINTENANCE REQUIREMENT DESCRIPTION				TOTAL M/H	
<ol style="list-style-type: none"> 1. Test AGC circuit. 2. Measure receiver sensitivity. 3. Test frequency locking action. 				0.5	
				ELAPSED TIME	
				0.5	
SAFETY PRECAUTIONS					
<ol style="list-style-type: none"> 1. Forces afloat comply with Navy Safety Precautions for Forces Afloat, OPNAVINST 5100 series. 2. When interlock switch is bypassed, voltages dangerous to life are present. 					
TOOLS, PARTS, MATERIALS, TEST EQUIPMENT					
<ol style="list-style-type: none"> 1. Headset 2. Adapter, UG-201A/U 3. 4" Light duty screwdriver 4. Electronic Counter, AN/USM-207 (SCAT 4296) 5. RF Signal Generator, HEWLETT-PACKARD 606B (SCAT 4363) or AN/URM-25() (SCAT 4362) 6. 6' Test cable, RG-58/U with BNC connector on each end 7. 6' Audio Test cable, BNC connector on one end and phone plug on other end 					
PROCEDURE					
Preliminary					
<ol style="list-style-type: none"> a. Turn ON test equipment, allow a 10-minute warmup. 					
LOCATION				DATE January 1978	
				N	

Page 1 of 5

18

CDQ5

PROCEDURE (contd)

1. Measure Receiver Sensitivity.
 - a. Set receiver switches and controls:
 - (1) MODE SELECTOR to LSB
 - (2) RF GAIN fully clockwise
 - (3) MCS and KCS to 02,010
 - (4) CPS to 000
 - (5) USB and LSB LINE LEVEL meter switches to 0 dB
 - b. Adjust signal generator for:
 - (1) Frequency approximately 150 kHz from receiver frequency
 - (2) RF output of 0.5 microvolt
 - (3) CW modulation
 - c. Adjust LSB LINE LEVEL control for -10 dB indication on LSB LINE LEVEL meter.
 - d. Adjust signal generator frequency and output controls for a peak on-scale LSB LINE LEVEL meter indication, then adjust signal generator output control for a zero-dB line level meter indication; signal generator output should be 1 microvolt or less.
 - e. Set receiver MODE SELECTOR to USB.
 - f. Substituting "USB" for "LSB", repeat steps 2.b. through 2.d. at 2.010 MHz.
 - g. Set receiver MCS and KCS switches successively to each frequency listed in table 1; substituting "USB" for "LSB", repeat steps 2.b. through 2.d. at each frequency selection.

MHz	MHz	MHz	MHz
3.101	10.898	17.010	24.010
4.222	11.989	18.010	25.010
5.333	12.010	19.010	26.010
6.444	13.010	20.010	27.010
7.555	14.010	21.010	28.010
8.666	15.010	22.010	29.010
9.777	16.010	23.010	

Table 1

- h. Set receiver switches and controls:
 - (1) BFO FREQ to midrange
 - (2) MCS and KCS to 02,010
- i. Adjust signal generator frequency to approximately 150 kHz from receiver frequency; set signal generator RF output to 2 microvolts and modulation to CW.
- j. Adjust USB LINE LEVEL control for -10 dB of noise on USB LINE LEVEL meter; set MODE SELECTOR switch to CW and adjust RF GAIN control for -10 dB of noise on USB LINE LEVEL meter.

PROCEDURE (contd)

- k. Adjust USB LINE LEVEL control to maintain an on-scale USB LINE LEVEL meter indication while adjusting signal generator frequency control for a peak line level meter indication; then adjust USB LINE LEVEL control for a zero-dB line meter indication.
- l. Detune signal generator off frequency; USB LINE LEVEL meter indication should decrease at least 10 dB.
- m. Set receiver MODE SELECTOR switch to AM; turn RF GAIN control fully clockwise.
- n. Adjust signal generator for:
 - (1) Frequency approximately 150 kHz from receiver frequency
 - (2) RF output of 4 microvolts
 - (3) Modulation of 1000 Hz at 30 percent
- o. Adjust USB LINE LEVEL control to maintain an on-scale USB LINE LEVEL meter indication, while adjusting a signal generator frequency control for a peak line level meter indication; then adjust the USB LINE LEVEL control for a zero-dB line meter indication.
- p. Set signal generator modulation switch to CW; USB LINE LEVEL meter indication should decrease at least 10 dB.
- q. Disconnect signal generator.

2. Test Frequency Locking Action.

- a. Set receiver switches and controls:
 - (1) MODE SELECTOR to USB
 - (2) MCS and KCS to 04,996
 - (3) CPS to 500
 - (4) RF GAIN fully clockwise
 - (5) USB and LSB LINE LEVEL meter switches to +20 dB
 - (6) USB and LSB LINE LEVEL fully counterclockwise
 - (7) USB and LSB PHONE LEVEL fully clockwise

NOTE 1: If rear of receiver is not accessible, connect frequency standard 5-MHz output to receiver antenna input at receive distribution or antenna patch panel; omit steps 3.b. through 3.f.

- b. Disconnect antenna cable from ANT jack J23.
- c. Loosen retaining screws and withdraw receiver chassis until mechanical stops engage.
- d. Note position of COMP-INT-EXT switch located on frequency standard assembly; set switch to COMP.
- e. Bypass interlock switch S8 behind upper right-hand corner of front panel.

WARNING: When interlock switch is bypassed, voltages dangerous to life are present.

- f. Remove cap from INT 5MC OUT jack J24; connect test cable between INT 5MC OUT jack and ANT jack J23 at rear of receiver cabinet.

PROCEDURE (contd)

- g. Ensure receiver audio is not patched to any undesired listening or remote position.
- h. Connect electronic counter input to USB PHONES jack, using audio test cable.
- i. Adjust USB LINE LEVEL control for -10 dB indication on USB LINE LEVEL meter.
- j. Set counter time base to 1 SEC; counter should indicate 3500 Hz.

NOTE 2: When the 5 MHz feeding the receiver antenna input is not from the same basic source as that being used to operate the receiver, the counter will reflect any frequency difference between the two standards.

- k. Adjust receiver frequency to 4,997.5 kHz; counter should indicate 2500 Hz.
- l. Adjust receiver frequency to 4,998.5 kHz; counter should indicate 1500 Hz.
- m. Adjust receiver frequency to 4,999.5 kHz; counter should indicate 500 Hz.
- n. Set MODE SELECTOR to LSB.
- o. Adjust receiver frequency to 5,003.5 kHz.
- p. Connect counter input to LSB PHONES jack.
- q. Adjust LSB LINE LEVEL control for -10 dB indication on LSB LINE LEVEL meter; counter should indicate 3500 Hz.
- r. Adjust receiver frequency to 5,002.5 kHz; counter should indicate 2500 Hz.
- s. Adjust receiver frequency to 5,001.5 kHz; counter should indicate 1500 Hz.
- t. Adjust receiver frequency to 5,000.5 kHz; counter should indicate 500 Hz.
- u. Set CPS switch to 000.
- v. Set MCS and KCS switches to 5,001; counter should indicate 1000 Hz.
- w. For R-1051/URR only, set CPS switch to 500; counter should indicate 1500 Hz.
- x. For R-1051B/URR only, set CPS switch successively from 000 to 900; counter indication should increase in 100-Hz increments from 1000 to 1900 Hz.
- y. Set CPS switch to VERNIER.
- z. Turn VERNIER control fully counterclockwise; counter should indicate a maximum of 980 Hz.
- aa. Turn VERNIER control fully clockwise; counter should indicate a minimum of 2020 Hz.
- ab. Set CPS switch to 000; counter should indicate 1000 Hz.

NOTE 3: Step 3.ac. may be performed and is acceptable, using either the internal or an external 5MHz source.

- ac. Set MCs switches successively from 02 to 29, in 1-MHz increments; counter should indicate 1000 Hz at each increment.

PROCEDURE (contd)

- ad. Disconnect counter from LSB PHONES jack.
- ae. Set MCS and KCS switches to 05,000.
- af. SET MODE SELECTOR to CW.
- ag. Connect headset to USB PHONES jack.
- ah. Turn BFO front panel control from fully counterclockwise to fully clockwise; a zero-beat note should be heard near midrange of control.
- ai. Disconnect test cable from INT 5MC OUT jack J24 and ANT jack J23, or disconnect frequency standard from receiver input. Reconnect ant input cable to J-23, if removed.
- aj. Disconnect headset from USB PHONES jack.
- ak. Set COMP-INT-EXT switch to position noted in step 3.d., if applicable.
- al. Slide chassis into cabinet; tighten retaining screws.
- am. Return equipment to current readiness condition.

Page 5 of 5

18

CDQ5

N

3.1.1.8 1J

SELF TEST ITEMS

1. If the -30 VDC is not present at 1A2A2 P1-19, the module will
 - a. have improper bias at the push-pull amplifier stages.
 - b. generate distortion in the product detector.
 - c. not generate proper AGC for the IF amplifier stages.
 - d. not generate proper AGC for the RF amplifier stages.

2. 1A2A2A3, R13, R18, and R23 across the secondaries of 1A2AA2, T2, T3, serve what purpose?
 - a. Lower the center frequency of tuning.
 - b. Raise circuit Q.
 - c. Broaden the bandwidth.
 - d. Raise the center frequency of tuning.

3. Between terminals 4 and 6 of audio output transformer 1A2A2A2T1, the impedance is 600 ohms center tapped. Between terminals 4 and 5 the impedance is
 - a. 100 ohms
 - b. 150 ohms
 - c. 300 ohms
 - d. 600 ohms

4. During ISB reception 1A2A2A1CR1 and 1A2A3A1CR1
 - a. allow the RF amplifier AGC to be controlled by the greater of the AGC voltage.
 - b. protect -30 VDC supply from transients
 - c. allow the RF amplifier AGC to be controlled by the smaller of the 2AGC voltage.
 - d. block RF from getting into the AGC circuits.

5. 1A2A2A2Q3 may best be described as
 - a. an amplifier.
 - b. an emitter follower for impedance matching.
 - c. a variable impedance device.
 - d. a clamping circuit.

6. An open 1A2A2A3Q1 or Q2 would
 - a. give no output from 1A2A2A3T1.
 - b. burn out 1A2A2A2T1.
 - c. give distorted output in AM operation.
 - d. cause distortion in the audio.

3.1.1.8 1J

7. An open 1A2A2A3Q1 or Q2 would best be isolated by
 - a. giving it a sharp rap.
 - b. replace both Q1 and Q2.
 - c. checking base bias.
 - d. checking emitter voltage.

8. In product detector 1A2A2 A3Q1-Q2, the sum mixer products are eliminated by a
 - a. bandpass filter.
 - b. low-pass filter.
 - c. high-pass filter.
 - d. resistance-capacitance network.

OVERVIEW

MODULE 3.1.2

AN/URT 24 TRANSMITTER

In this module you will learn about the AN/URT-24 Transmitter which comprises the transmit function of the AN/WRC-1B. The AN/URT-24 consists of the following units: T-827 Transmitter, AM-3007 RF Amplifier, and the CU-937 Antenna Coupler. You will learn the different types of signals that can be transmitted and how to operate the transmitter. You will learn the function of each part in the receiver and how to check its operation. You will perform tests and adjustments and troubleshoot a faulty transmitter.

The Terminal Objective of this module is:

3.3 ISOLATE a malfunction in the AN/URT-24 Transmitter to the faulty part, given the technical manual, MRC, tools and test equipment. A minimum score of 70% must be achieved, based on locating the faulty part, procedure, safety and time.

This module is divided into seven lessons:

Lesson 3.1.2.1 Radio Transmitter Operation and Familiarization

Lesson 3.1.2.2 AN/URT-24 Functional Block Analysis

Lesson 3.1.2.3 T-827 Chassis Main Frame Circuit Analysis

Lesson 3.1.2.4 T-827 FSK Tone Generator and AF Amplifier Circuit Analysis

Lesson 3.1.2.5 T-827 Transmit Mode Selector Circuit Analysis

Lesson 3.1.2.6 T-827 IF Amplifier Circuit Analysis

Lesson 3.1.2.7 AM-3007 and CU-937 Circuit Analysis

ASSIGNMENT SHEET 3.1.2.1 1A

AN/URT-24 RADIO TRANSMITTER OPERATION AND FAMILIARIZATION

INTRODUCTION:

This assignment sheet is comprised of three parts. Part I is designed to give you practice in using the Technical Manual to obtain information.

Part II is a reading assignment of the functional block analysis of the AN/URT-24B which will prepare you for the next lesson topic.

Part III consists of a reading assignment on the AC and DC power distribution in the AN/URT-24B, and the T-827 B/URT. You will also be color coding these distribution systems on your chassis and maintenance schematics.

LESSON TOPIC LEARNING OBJECTIVES(S)

3.1.2.1.1 Given sets of specifications concerning type of transmitter, frequency range, RF power output, control signals, and AC power input, SELECT the set of specifications that apply to the AN/URT-24 Transmitter.

3.1.2.1.2 TEST/OPERATE Radio Transmitter AN/URT-24, when given the operator's handbook, in accordance with Job Sheet 3.1.3.1 1J.

STUDY QUESTIONS: Refer to Homework Handout

3.1.2.1 1A-H

The key points to look for in this reading assignment are

1. Major signal path processing
2. Inputs and outputs of each function in the processing
3. Conversions accomplished and/or function of each function

Use functional block diagram on page 47 of Student Guide Volume 3, part 2 as an organizer.

STUDY ASSIGNMENT PART III: T-827B/URT AC AND DC POWER DISTRIBUTION

A. Read and study pages 3-79 (Para 3-214) through page 3-84 (Para 3-219) WRC-1B Technical Manual Vol 1.

B. Trace the power distribution of all AC and DC voltages using the chassis and mainframe schematic diagram of the T-827B in the Student Guide Volume 3. Figures 1 through 8 will aid in locating the circuits on the schematic diagrams located in the rear of the assignment sheet.

C. All power is derived from the 115 VAC line connected to 2A1J4 on the rear of the case. The power supply consists of +110 VDC, +28VDC, 6.3 VDC, +20 VDC, and +12 VDC. The 20 V and 12 V are derived from the 28 VDC. A +4 VDC is derived from the 20 VDC.

1. TRACE the 115 VAC COMMON line using black as a recommended color starting at 2A1J4 pin S (20-G) on page 11 and using Figure 1.
2. TRACE the 115 VAC HOT line using red as a recommended color starting at 2A1J4 pin R (20-G) on page 11 and using Figure 1.
 - a. What position is 2A2S7 shown in? _____
 - b. In what position(s) of 2A2S2 will the 115 VAC be applied to 2A2T1? _____
3. TRACE the 6.3 VAC from 2A2T1 pin 13, 14 to the 2A2A4 RF amplifier using yellow as the recommended color on page 11 using Figure 2.
 - a. What is the purpose of 6.3 VAC supply? _____
4. TRACE the 110 VDC using blue as the recommended color on page 11 (8-C) and using Figure 3.

NOTE: The +110 VDC at K3, pin 7 is xmit +110 V. USE DASHED BLUE lines to code this line.

- a. What is the purpose of the +110 VDC? _____
 - b. What would the symptoms be if +110 failed? _____
5. TRACE +28 VDC line using green as a recommended color on page 11 using Figure 4 starting at L2 terminal 2 (9-D)

3.1.2.1 1A-H

NOTE: The +28 at K1, pin 6 is called Interlocked +28 V. USE DASHED GREEN lines to code this line.

The following is a list of purposes of the +28 V at the various jacks.

- a. 2A2J11-7 Turret drive relay and motor
- b. 2A2J12-7 MHz synthesizer
- c. 2A2J9-2 Crystal oven
- d. 2A1J4-M To interconnection box J-1265, K1, PA, PWR ON

6. TRACE +20 VDC line using purple as the recommended color on page 11 and using Figure 5.

NOTE: The +20 at K3 pin 12 is xmit +20. Use a DASHED PURPLE line to code this line using Figure 6.

NOTE: The dotted lines on Figure 6 are +20 VDC controlled by positions of MODE SELECT SWITCH. USE DOTTED PURPLE to code these lines.

The following is a list of purposes of the +20 V at

- a. 2A2J12-10 Module biasing
- b. 2A2J12-18 REC +20 : disables A6 RF Translator
- c. 2A2J9-1 Transistor biasing
- d. 2A2J17-9 Diode gate biasing (SSB Carrier reinsertion)
LEVELGATE, USB SIDETONE GATE, CW SIDETONE GATE
- e. 2A2J15-10 Transistor biasing
- f. 2A1J4-N AM-3007 APC, PPC Amplifiers
- g. 2A2J11-11 Xmit +20 for A38 board
- h. 2A2J12-16 Xmit +20 for RF Translator
- i. 2A2J12-20 Xmit +20 for LO filter selection
- j. 2A2J20-1 Transistor biasing an FSK, ISB/FSK
- k. 2A2J19-17 Transistor biasing in LSB, ISB, ISB/FSK
- l. 2A2J18-17 Transistor biasing in USB, AM, FSK, ISB, ISB/FSK
- m. 2A2J16-2 Isolation Amp biasing in LSB, ISB, ISB/FSK
- n. 2A2J16-5 Isolation Amp biasing in USB, AM, FSK, ISB, ISB/FSK
- o. 2A2J17-2 500 kHz Amp biasing in LSB, ISB, ISB/FSK
- p. 2A2J17-8 500 kHz Amp biasing in USB, AM, FSK, ISB, ISB/FSK
- q. 2A2J17-20 Xmit +20 for 500 kHz gate, CW carrier gate, AM
carrier gate, LSB sidetone gate
- r. 2A2J17-7 All modes except CW for 500 kHz gate, SSB carrier
reinsertion level gate
- s. 2A2J17-10 Biasing for CW carrier gate, CW sidetone OSC
- t. 2A2K17-4 Biasing for AM carrier gate
- u. 2A1J4-T AM-3007 Tuning

7. TRACE the +12 VDC on page 11 (10-F) using Figure 7 and using pink as the recommended color.

- a. The +12 V at J1 pin D when handset is connected, is driven for carbon mike oil, is passed through PTT button switch on handset to J1-6.

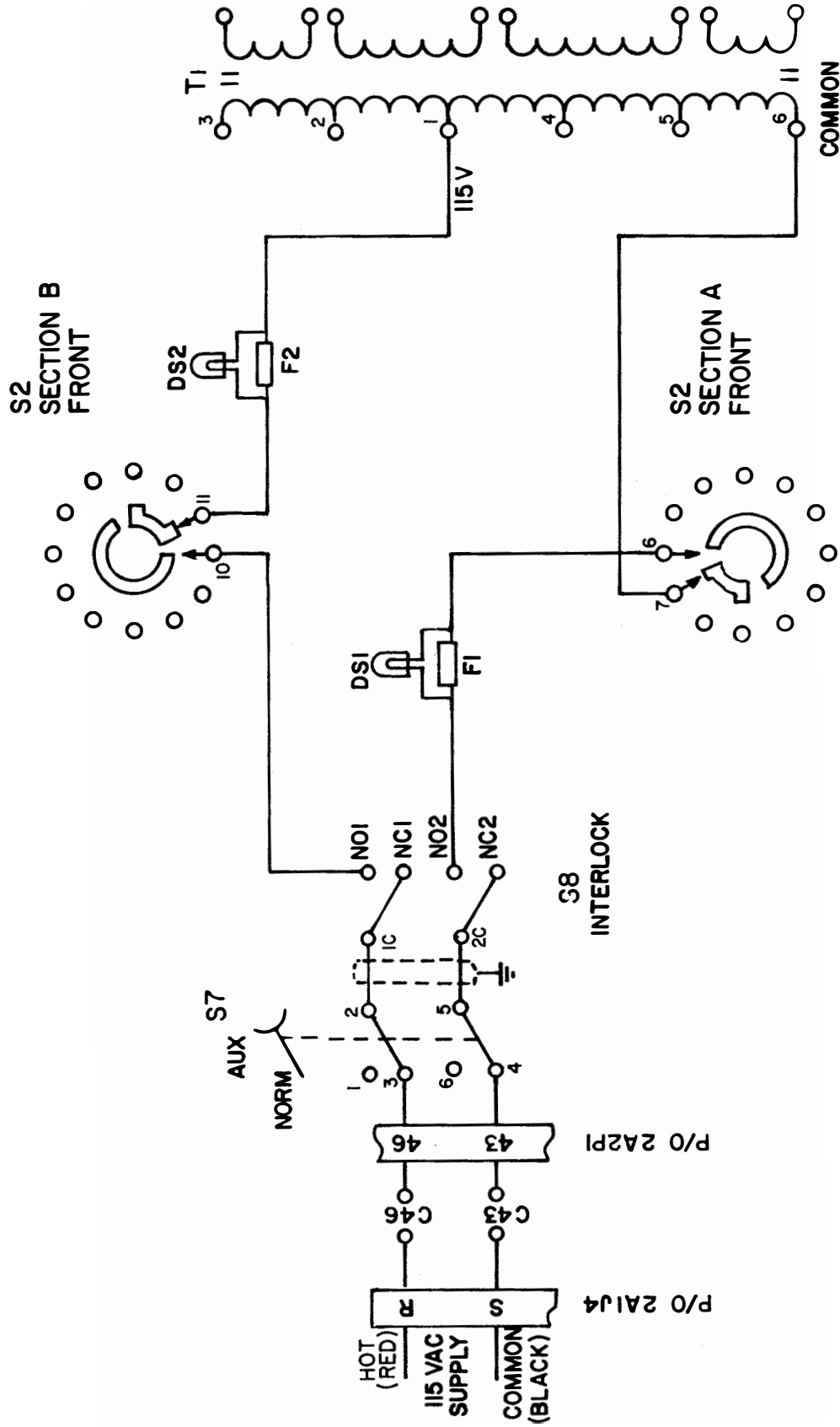

FIGURE 1

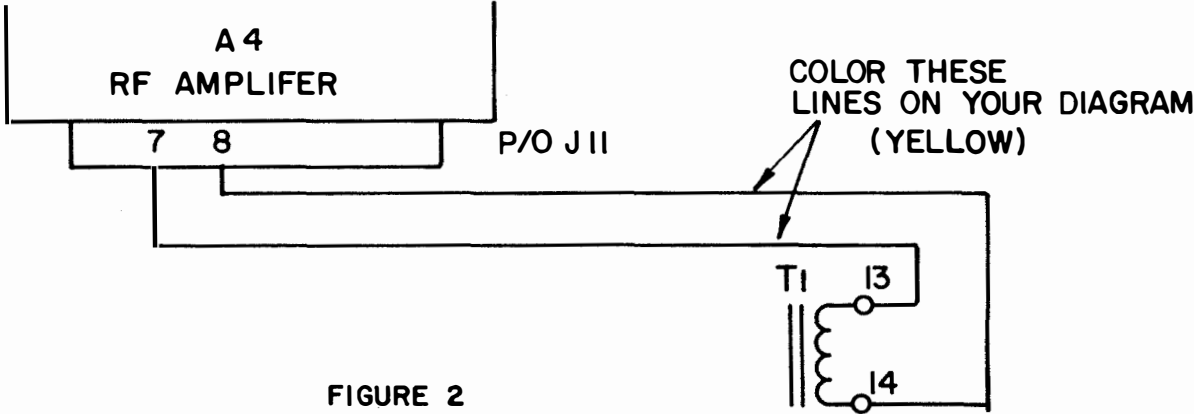

FIGURE 2

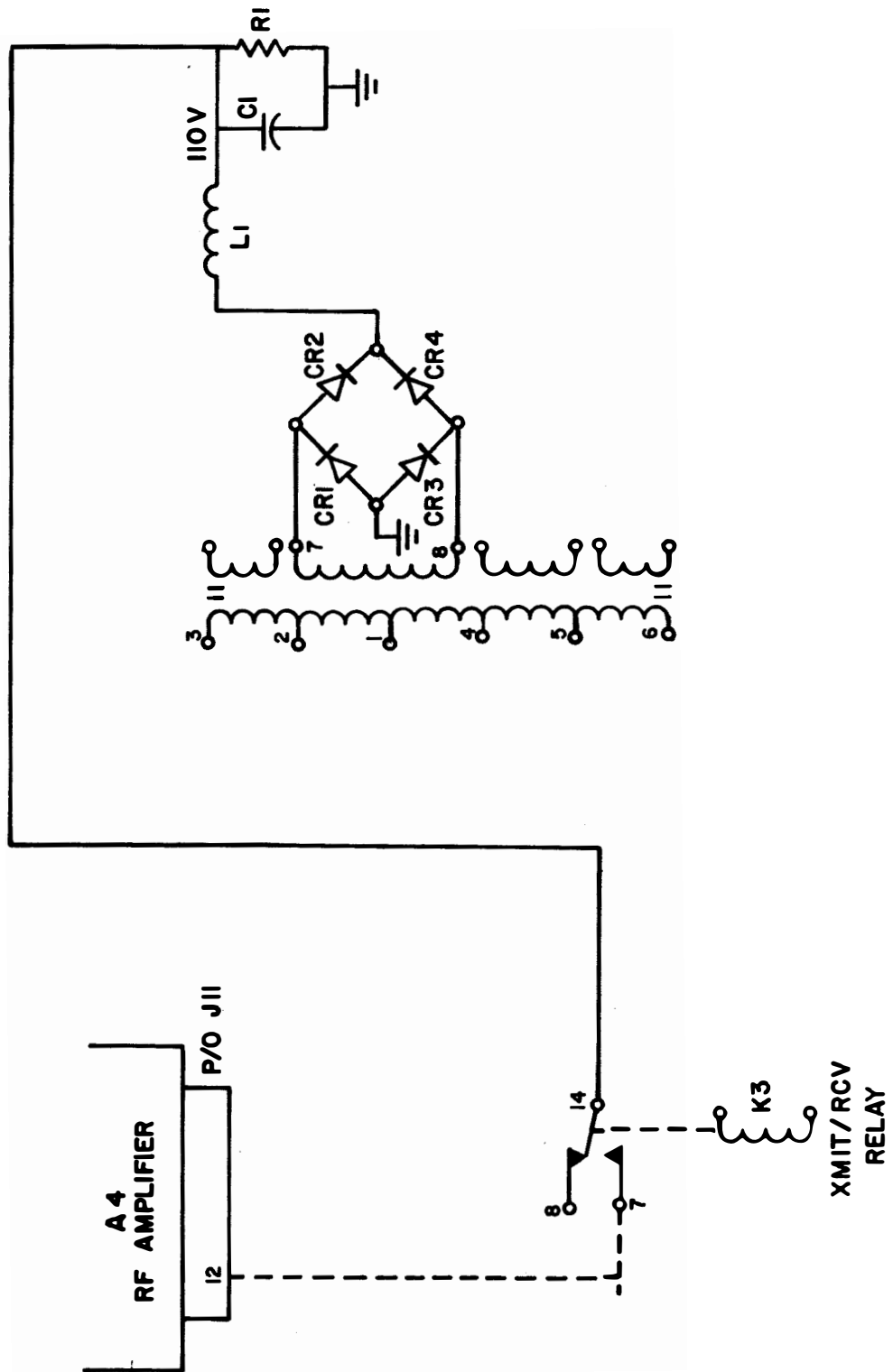

FIGURE 3

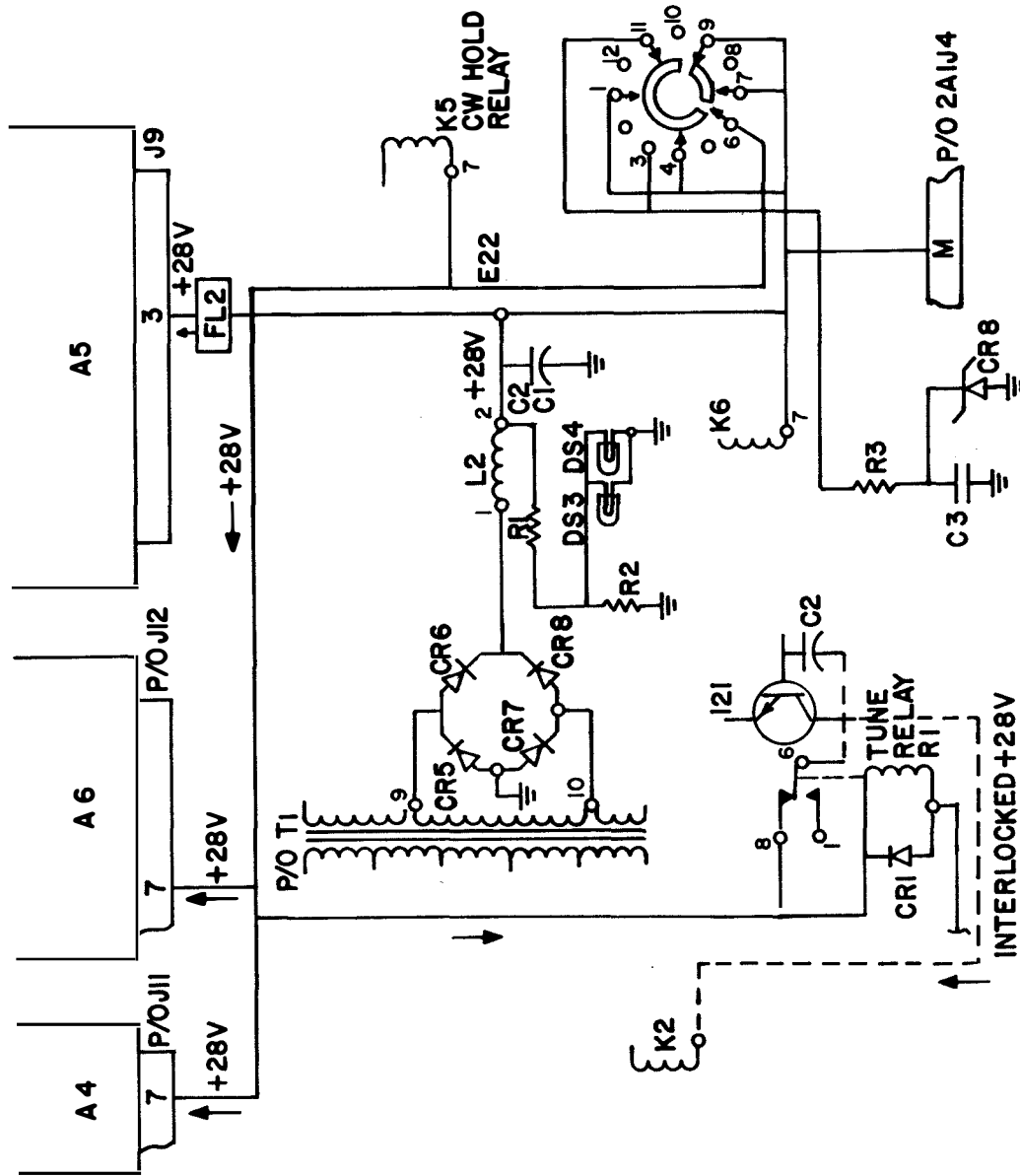

FIGURE 4

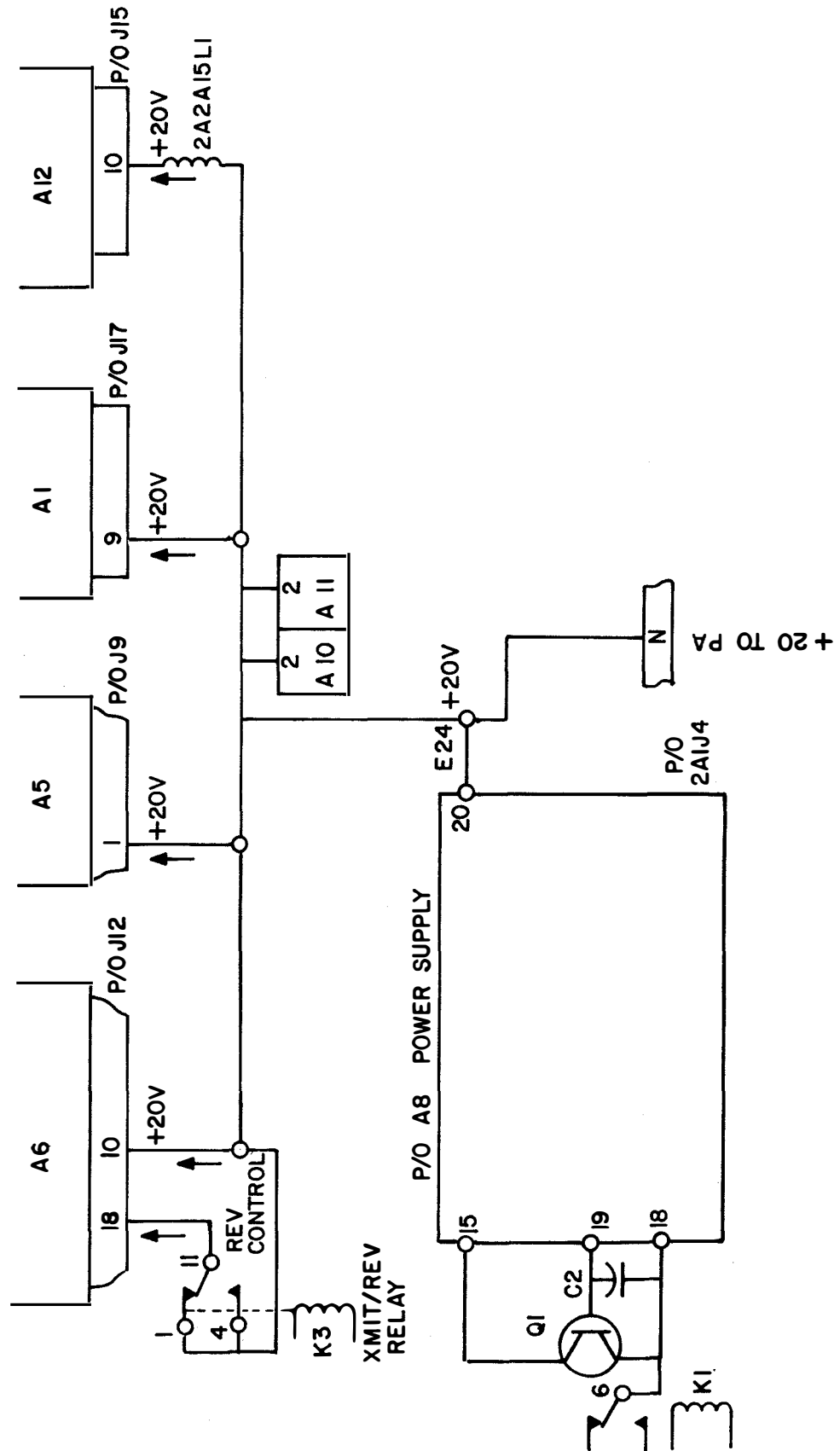

FIGURE 5

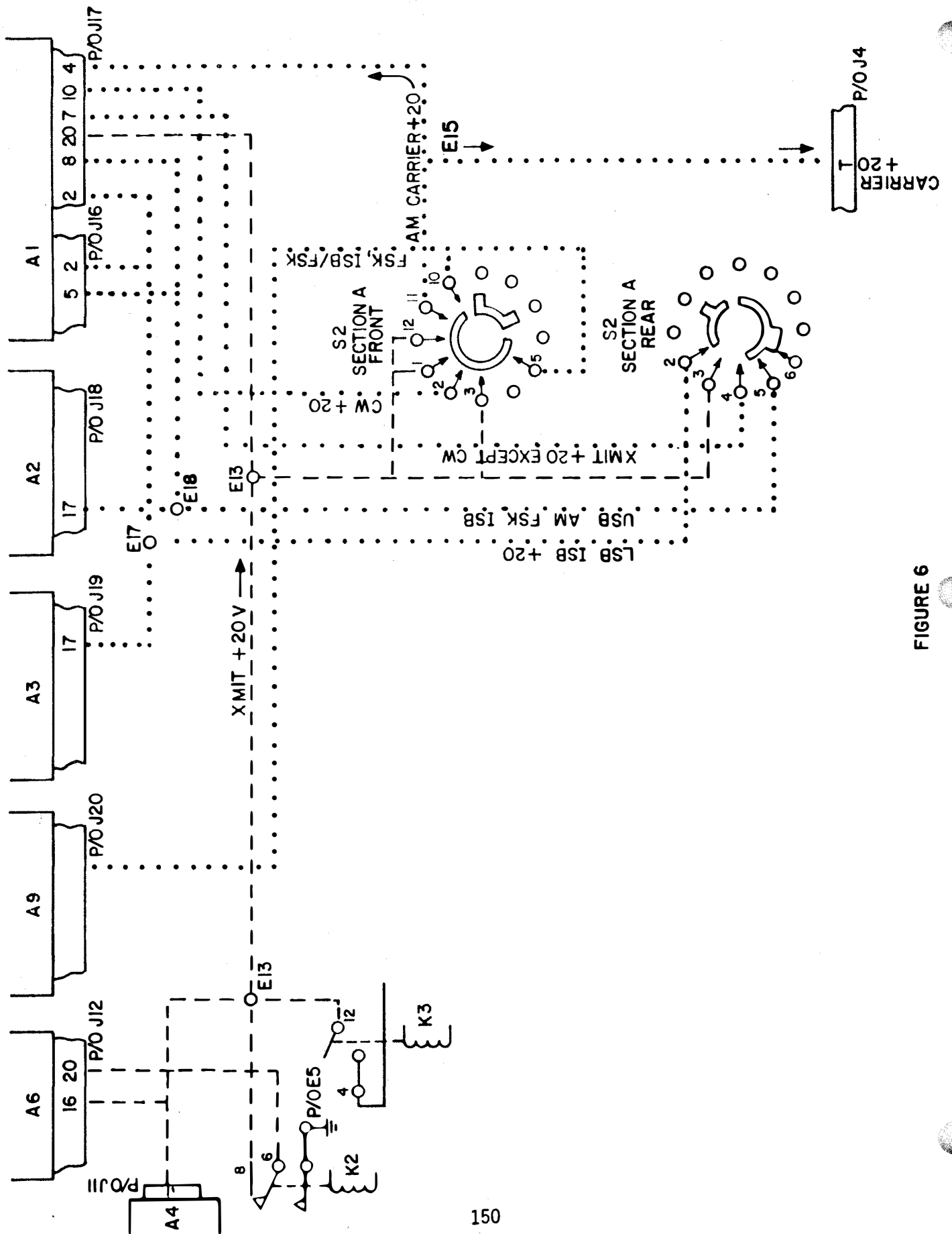

FIGURE 6

3.1.2.1 1A -H

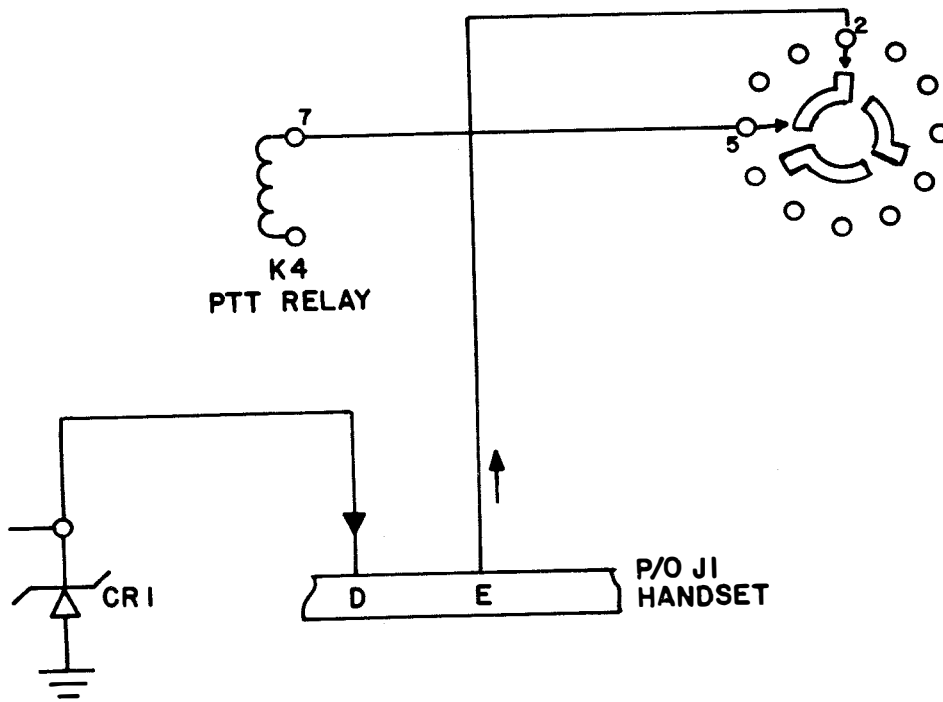
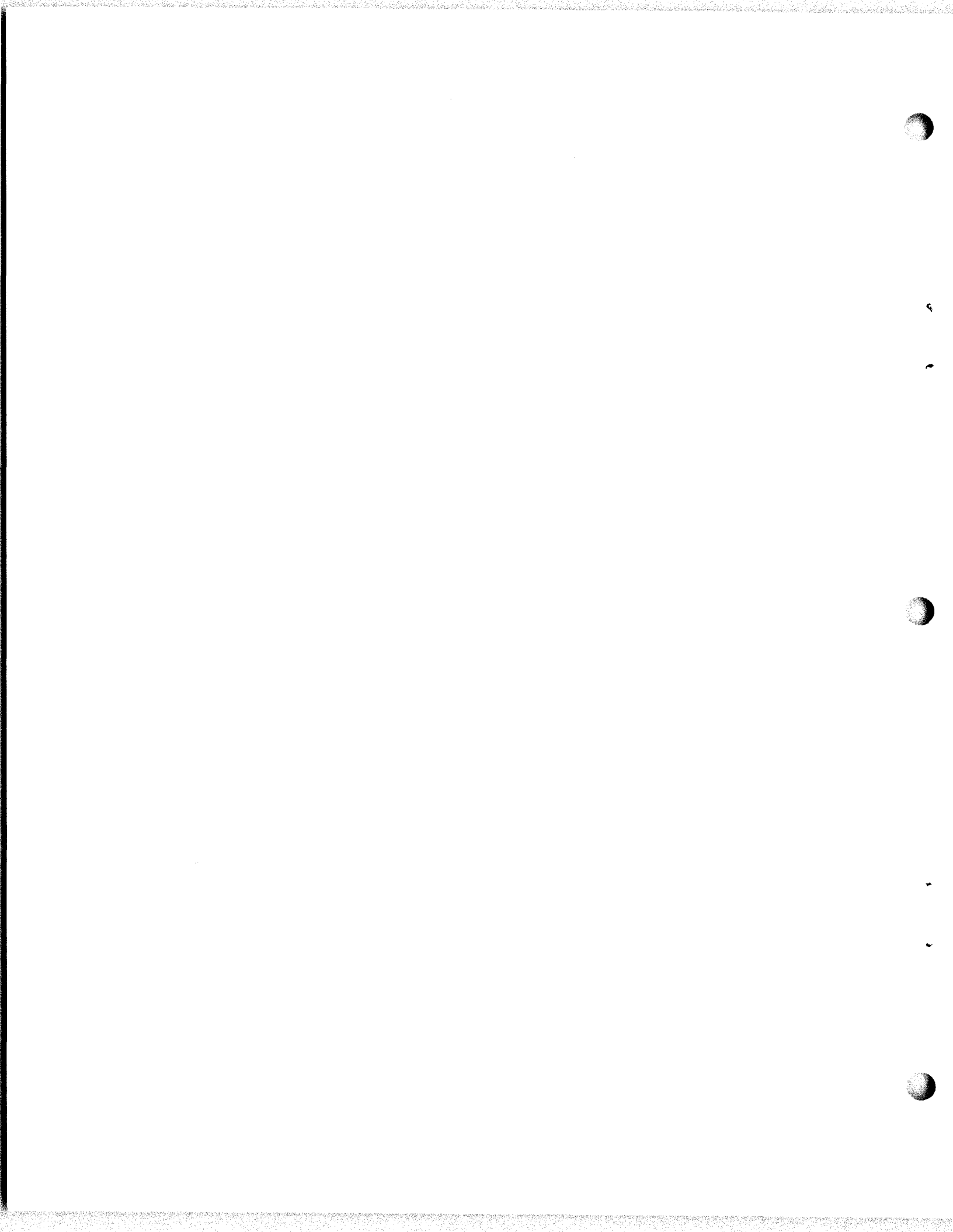

FIGURE 7



JOB SHEET

AN/URT-24B: OPERATION AND FAMILIARIZATION

JOB SHEET NO. 3.1.2.1 1J

INTRODUCTION:

This job sheet will provide hands on experience in operating an AN/URT-24B Transmitter for maintenance purposes. It will involve transmitter, performing operational tests and checks utilizing Maintenance Requirement Cards (MRC's). These experiences are necessary for a technician to determine the status of his equipment. The operational checks will aid in determining if a malfunction exists.

LESSON TOPIC LEARNING OBJECTIVES (S):

3.1.2.1.1 Given sets of specifications concerning type of transmitter, frequency range, RF power output, control signals, and AC power input, SELECT the set of specifications that apply to the AN/URT-24 Transmitter.

3.1.2.1.2 TEST/OPERATE Radio Transmitter AN/URT-24, when given the operator's handbook, in accordance with Job Sheet 3.1.2.1 1J.

REFERENCES:

NAVSHIPS 0967-427-5010 Technical Manual For AN/WRC-1B And CU-937/UR, Vol. 1
NAVSHIPS 0967-427-5020 Technical Manual (Operation Instructions) AN/WRC-1B
OPNAV 4700-1 (A) Maintenance Requirement Card (MRC) Rev 3-69 AUT9 Dated May 1974

EQUIPMENT and MATERIALS:

1. AN/URT-24B Transmitter
- 2 Maintenance Requirement Cards C-304, W2

General: Observe all safety precautions

JOB STEPS.

Part I: TEST/OPERATE RADIO TRANSMITTER.

During this part you will be making adjustments to different controls and observing indications for desired responses. This should not be just a mechanical action on your part but rather be alert to the indications as both normal and abnormal ones are clues to a well trained mind.

1. Obtain a tool kit for your position from the lab instructor.

3.1.2.1 1J

PART I: (cont'd)

2. Refer to the Maintenance Requirement Card (MRC) C-304 W-2 on the following pages and perform all the steps on the MRC. This MRC has been modified to meet the needs of the lab. It is not the actual C-304 W-2 MRC used in the fleet.

3.1.2.1 1J

SHIP SYSTEM COMBAT		SUBSYSTEM		MRC CODE C-304 W-2	
SYSTEM COMMUNICATIONS		EQUIPMENT AN/URT-24 RADIO TRANSMITTER		RATES ETSN	M/H 0.2
MAINTENANCE REQUIREMENT DESCRIPTION				TOTAL M/H 0.2	ELAPSED TIME 0.2
SAFETY PRECAUTIONS COMPLY WITH NAVY SAFETY PRECAUTIONS FOR FORCES AFLOAT, OPNAVINST 5100 SERIES.					
TOOLS, PARTS, MATERIALS, TEST EQUIPMENT NONE					
PROCEDURE					
NOTE: This procedure was developed using the CU-937/UR antenna coupler. If other couplers used procedure will have to be modified.					
1. Test Operate Radio Transmitter					
<ul style="list-style-type: none"> a. Set transmitter frequency selectors to test frequency authorized by SOPA (low end of transmitter frequency range). b. Set MODE SELECTOR to AM. Allow 5-minute warmup. c. Set RF-OUTPUT METER switch to 100W REFL. d. Adjust ANT CPLR LOAD and ANT CPLR TUNE switches for required number of flashes of ANT CPLR TUNE indicator in accordance with chart for antenna installed. (REFER TO NAVSHIPS 0967-427-5020 TECHNICAL MANUAL VOL II PAGE 2-19 TUNING CHART) e. Hold RF OUTPUT TUNE/OPERATE switch to TUNE and alternately adjust ANT CPLR TUNE and ANT CPLR LOAD switches to minimum indication of RF OUTPUT meter. f. Set RF OUTPUT meter switch to 30W REFL. g. Repeat step 1, e. Meter should indicate in black area at left of meter scale. h. Set RF OUTPUT meter switch to 100 W FWD. Meter should indicate approximately 25. i. Repeat steps 1.c. through 1.h., using test frequencies authorized by SOPA at middle and high end of transmitter frequency range. j. Return equipment to normal readiness condition. 					
LOCATION				DATE May 1974	

PAGE
OF

MAINTENANCE REQUIREMENT CARD (MRC)

ASSIGNMENT SHEET 3.1.2.2 1A

AN/URT-24B, FUNCTIONAL BLOCK ANALYSIS

INTRODUCTION:

This assignment sheet is comprised of two parts. Part I is designed to give you practice in using the Technical Manual and the Functional Block Diagram to obtain information.

Part II is a reading assignment on the Power Distribution in the AN/URT-24B which will prepare you for the next lesson topic.

LESSON TOPIC OBJECTIVES:

3.1.2.2.1 IDENTIFY the function of each block in the functional block diagram of the AN/URT-24 Transmitter by matching the name of each block to the function, given the block diagram and a list of functions.

3.1.2.2.2 IDENTIFY signal distribution paths in the AN/URT-24 Transmitter by matching each signal designation to the statement describing its distribution path, given the functional block diagram, a set of signal designations, and a list of statements describing signal distribution paths.

3.1.2.2.3 IDENTIFY the AC and DC voltage distribution paths in the AN/URT-24 Transmitter by matching each voltage designation to the description of its distribution path, given the main frame and chassis schematic diagram, a list of AC and DC voltages, and a list of statements describing each voltage distribution path.

3.1.2.2.4 VERIFY the operation of the AC and DC voltage distribution system in the AN/URT-24 Transmitter by measuring voltage at specified test points and comparing results with the technical manual specifications, given the AN/URT-24 technical manual, test equipment, and a Job Sheet specifying the test points.

STUDY QUESTIONS: Refer to Homework Handout

3.1.2.2 1A -H

STUDY ASSIGNMENT:

PART I: AN/URT-24B Technical Manual and Functional Block Diagram.

1. Draw a block diagram for the AN/URT-24B showing the signal path for the CW Mode of Operation. Identify each subassembly with it's name and alphanumeric designation.
2. What are the Frequency Outputs of the Frequency Standard and what are the jack locations they are applied to?

FREQUENCY:

JACK:

3. What position should the transmitter Mode Selector Switch be placed in prior to removing or replacing a module?

4. What module is the FSK square wave applied to?

5. The Translator/Synthesizer converts _____ to _____

6. The 500 kHz carrier signal used in the CW Mode of Operation is applied to the base of what transistor (Use Complete Reference)?

7. The equipment developed a problem whereby you cannot transmit in any mode. What would you use to isolate the problem down to the T827/URT, AM-3007/URT, or CU-937/URT?

PART II: Read the informational description on the T-827B/URT, DC power supply circuit description. This description is located on page 3-79 (para 3-215) through 3-84 (para 3-219).

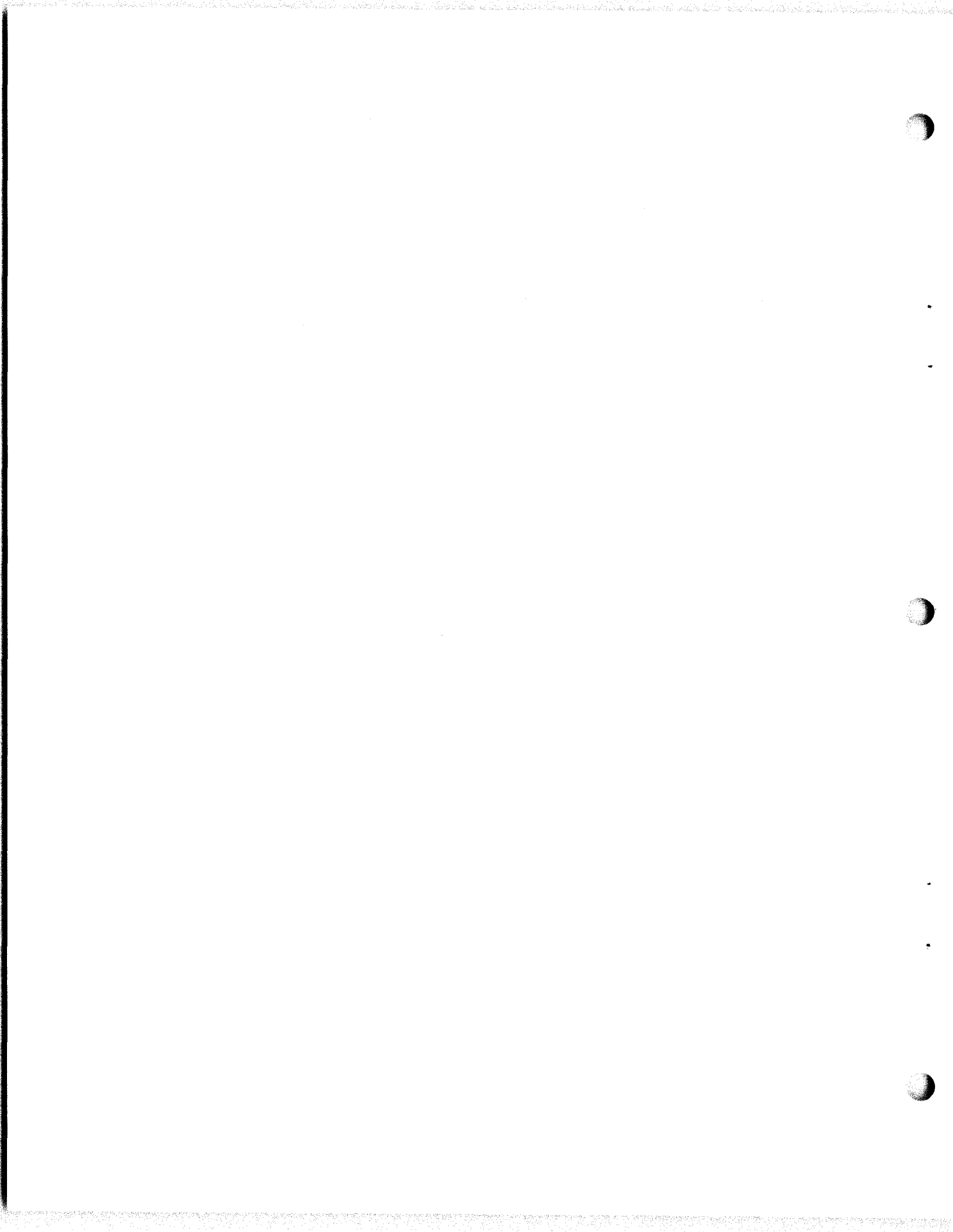

JOB SHEET

AN/URT-24B, SIGNAL VERIFICATION

JOB SHEET NO. 3.1.2.2 1J

INTRODUCTION

This job sheet will provide hands on experience in Modular Signal Tracing for the purpose of signal verification. It will involve physically removing modules, performing operational signal tests, and utilizing the functional block diagram in your Student Guide.

These experiences are necessary for a technician to determine the status of a module. You will also make physical inspections after the module is out to see if any connector pins are missing or bent facilitating repair.

LESSON TOPIC LEARNING OBJECTIVES:

3.1.2.2.1 IDENTIFY the function of each block in the functional block diagram of the AN/URT-24 Transmitter by matching the name of each block to the function, given the block diagram and a list of functions.

3.1.2.2.2 IDENTIFY signal distribution paths in the AN/URT-24 Transmitter by matching each signal designation to the statement describing its distribution path, given the functional block diagram, a set of signal designations, and a list of statements describing signal distribution paths.

3.1.2.2.3 IDENTIFY the AC and DC voltage distribution paths in the AN/URT-24 Transmitter by matching each voltage designation to the description of its distribution path, given the main frame and chassis schematic diagram, a list of AC and DC voltages, and a list of statements describing each voltage distribution path.

3.1.2.2.4 VERIFY the operation of the AC and DC voltage distribution system in the AN/URT-24 Transmitter by measuring voltages at specified test points and comparing results with the technical manual specifications, given the AN/URT-24 technical manual, test equipment, and a Job Sheet specifying the test points.

REFERENCES:

NAVELEX 0967-LP-427-5010, Technical Manual for Radio Set AN/WRC-1B, Volume I

EQUIPMENT AND MATERIALS:

1. AN/URT-24B Radio Set (1)
2. Oscilloscope (1)
3. Tool Kit (1)
4. Frequency Counter (1)

GENERAL:

Observe all safety precautions.

3.1.2.2 1J

JOB STEPS:

Precautions to be observed: Before removing or replacing any module make sure the primary power is secured, either the mode selector switch is turned off or the interlock switch is in the proper position. Use extreme caution when removing or replacing the modules because of the pin connectors on the bottom of the module damage easily.

Step 1. Energize bulkhead Circuit Breaker. Turn 3A2A1CB1 (Primary Power On-Off Circuit Breaker) switch ON. Place 3A2A1S2 (Primary Power) to the AC/INT BAT Position. Place 3A2A1S3 (RF Output Meter Switch) to the 100 w REFL Position. Finally turn the 2A2S2 (Transmitter Mode Selector Switch) to STANDBY and allow 5 minutes for warm-up.

Step 2. Set up all the test equipment required to complete this job sheet.

- a. Turn the AN/USM-117 ON and adjust it for the finest possible trace.
- b. Zero the AN/USM-116 on the AC 10 V scale.

Step 3. Set the T-827B/URT front panel dials to read 8.0 MHz.

Step 4. Perform the operating control settings.

- a. LSB Line Level Switch (S10) to +10 dB position.
- b. Local/Remote Switch (S1) to Local.
- c. USB Line Level Switch (S11) to +10 dB position.

Step 5. Unscrew the six holding screws and slide the drawer out until it locks into position.

IMPORTANT: Make sure the kHz controls are set for 000 to insure the cams on the bottom of the translator/synthesizer and the cams on the receiver chassis will line up correctly.

- a. AUX/NORM Power Switch (S7) to NORM.

Step 6. Locate the USB AF AMP and unscrew the hold-down screws and pull out the module from the chassis.

Step 7. Defeat the Interlock Switch (2A2S8) and place the Mode Selector Switch to FSK Mode of Operation. Place the FSK Key Toggle Switch to the keyed position. Also place the MARK/SPACE Toggle Switch to the MARK position.

3.1.2.2 1J

Step 8. Place the AC probe at 2A2J18-20, observe and record the Peak-to-Peak signal level displayed on the oscilloscope. Then repeat this step for the Space position.

2A2J18-20 MARK: _____

2A2J18-20 SPACE: _____

Unkey the FSK Key Toggle Switch.

2A2J18-12 _____

Step 9. Deenergize the transmitter and place the USB AF AMP module back in the equipment. With the transmitter still deenergized remove the Transmit Mode Selector module from the chassis.

Step 10. Reenergize the transmitter and place the AC probe at each of the following locations and observe the peak-to-peak signal level on the oscilloscope. Record your reading in the space provided.

a. First with the Mode Selector Switch in LSB make a signal check at 2A2J17-A3 and record your observation.

2A2J17-A3 _____

b. Take the local handset, key the PTT stall in LSB and talk into the mouth piece. Observe and record the signal level at 2A2J17-1.

2A2J17-1 _____

c. Turn the Mode Selector Switch to the USB position. Take the local handset, key the PTT button and talk into the mouth piece. Record your observation at 2A2J17-11.

2A2J17-11 _____

d. Turn the Mode Selector Switch to the FSK position and place the FSK key to the Key position. Record your observation at 2A2J17-11.

2A2J17-11 _____

3.1.2.2 1J

- Step 11. Deenergize the transmitter and replace the Transmit Mode Selector module back in the equipment. While the equipment is still deenergized remove the IF Amplifier from the chassis.
- Step 12. Reenergize the transmitter and place the AC probe at each of the following locations and observe the peak-to-peak signal level on the oscilloscope. Record your reading in the space provided.
- a. Place the Mode Selector Switch in the USB Mode of Operation. Push the PTT button and repeat test 1-2-3. Record your observations in the space below.

2A2J15-A3 _____

2A2J15-A2 _____

NOTE: Remember the signal at 2A2J15-A3 is going to be a very small signal level.

- b. Turn the Mode Selector Switch to the CW Mode of Operation. Place the CW Key into the CW Key Jack (which keys the system in CW). Record your observations in the space below.

2A2J15-A3 _____

2A2J15-A2 _____

IMPORTANT: Make sure the kHz controls are set for 000 to insure the cams on the bottom of the translator/synthesizer and the cams on the receiver chassis will line up correctly.

- Step 13. Reenergize the transmitter and place the AC probe at each of the following locations and observe the peak-to-peak signal level on the oscilloscope. Record your readings in the space provided. Place the Mode Selector Switch into the CW Mode of Operation with the CW key installed.

2A2J12-A1 _____

2A2J12-A2 _____

2A2J12-A3 _____

2A2J13-A2 _____

3.1.2.2 1J

- Step 14. Deenergize the transmitter and place the translator/synthesizer module in the equipment. Observe caution with this module. While the equipment is still deenergized remove the RF AMP module from the chassis.
- Step 15. Reenergize the transmitter and place the AC probe at 2A2J11-A5 and observe the peak-to-peak signal level on the oscilloscope. Insure that you are set up for CW transmission. Record your observation.

2A2J11-A5

- Step 16. Deenergize the transmitter and place the RF AMP module back in the equipment.
- Step 17. Bring your completed job sheet up for the Instructor to check your work before securing the equipment.

INSTRUCTOR'S SIGNATURE

- Step 18. Secure the position and the equipment the way you found it. Then go back to your seat and complete the SELF TEST QUESTIONS.

SELF-TEST ITEMS:

1. What mode of operation would use the same signal path as the CW Mode of Operation?

2. 2A2M2 (USB Line Level Meter) should have displayed how much of a deflection in the CW Mode of Operation?

T-827B/URT TRANSMITTER AC AND DC POWER
DISTRIBUTION SYSTEM

INTRODUCTION:

This assignment sheet is comprised of two parts. Part I is designed to give you practice using and reading a chassis main frame schematic diagram to obtain information.

Part II is a reading assignment on the following circuit description in the technical manual on the FSK tone generator and the audio amplifiers to prepare you for next lesson topics. Read starting on page 3-42 (Par. 3-1319) through page 3-54 (Par 3-155) in the AN/WRC-1B Vol. I Technical Manual.

LESSON TOPIC OBJECTIVE(S):

3.1.3.1 IDENTIFY the assembly and component parts that comprise the MCS tuning circuit in the T-827 Transmitter, when given the technical manual, by selecting from a list of assemblies and component parts.

3.1.3.3.2 IDENTIFY the tuning circuits controlled by the code generator in the T-827, when given the technical manual, by selecting from a list of tuning circuits.

3.1.3.3.3 IDENTIFY the distribution path(s) of the T-827 Code Generator by selecting from a list of sequenced component parts the one which describes a distribution path. Given the technical manual for the T-827 Transmitter.

3.1.3.3.4 IDENTIFY the function of each relay in the distribution path of the T-827 Code Generator when given the technical manual and relay nomenclature, by selecting from a list the function of the relay identified.

3.1.3.3.5 IDENTIFY the main frame and control switches by matching the noun name of the switch to the nomenclature of the switch, given the T-827 technical manual.

3.1.3.3.6 IDENTIFY the sources and distribution paths of signals for each of the switches which comprise the mainframe and control switch group. Given the technical manual, by selecting from a list of sequenced component parts the one which describes the source and distribution path.

3.1.3.3.7 IDENTIFY the function of each relay in the distribution path of the main frame and control switch group when given the technical manual relay nomenclature, by selecting from a list the function of the relay identified.

STUDY QUESTIONS: Refer to Homework Handout

ASSIGNMENT SHEET 3.1.2.4 1A

T-827B FSK TONE GENERATOR AND AF AMPLIFIER CIRCUIT ANALYSIS

INTRODUCTION:

This assignment sheet is comprised of two parts: Part I is designed to give you practice using the technical manual to obtain information.

Part II is a reading assignment on the Radio Transmitter T-827B/URT, main signal flow circuit description for the Mode Selector Electronic Assembly 2A2A1. It starts on page 3-26 (Par. 3-84) through page 3-35 (Par. 3-107).

LESSON TOPIC OBJECTIVES:

3.1.2.4.1 IDENTIFY the function of each block in the functional block diagram of the T-827 tone generator by matching the name of each block to the function. Given the block diagram and a list of functions.

3.1.2.4.2 IDENTIFY the amplitude and frequency of signals at specified test points in the T-827 tone generator by selecting the amplitude and frequency of the signal from a list. Given the specified test point and the T-827 technical manual.

3.1.2.4.3 IDENTIFY the function of each part in the T-827 tone generator, given a list of part functions and the T-827 technical manual.

3.1.2.4.4 PERFORM the FSK tone adjustment on the T-827 tone generator. Given a T-827 technical manual, test equipment and a job sheet with procedures specified.

3.1.2.4.5 VERIFY the operational status of the T-827 tone generator by monitoring waveforms and measuring voltages at specified test points and comparing results with technical manual specifications. Given a T-827 technical manual test equipment, and a job sheet with procedures and test points specified.

3.1.2.4.7 IDENTIFY the amplitude and frequency of signals at specified test points in the T-827 audio amplifiers by selecting the amplitude and frequency of the signals from a list. Given the specified test points and the T-827 technical manual.

3.1.2.4.8 PERFORM the gain adjustment on the T-827 audio amplifier assembly. Given the T-827 technical manual, test equipment and a job sheet with procedures.

3.1.2.4.9 VERIFY the operational status of the T-827 audio amplifiers by monitoring waveforms, and measuring voltages at specified test point and comparing results with technical manual specifications. Given the T-827 technical manual, test equipment, and a job sheet with procedures and test points specified.

STUDY QUESTIONS: Refer to Homework Handout

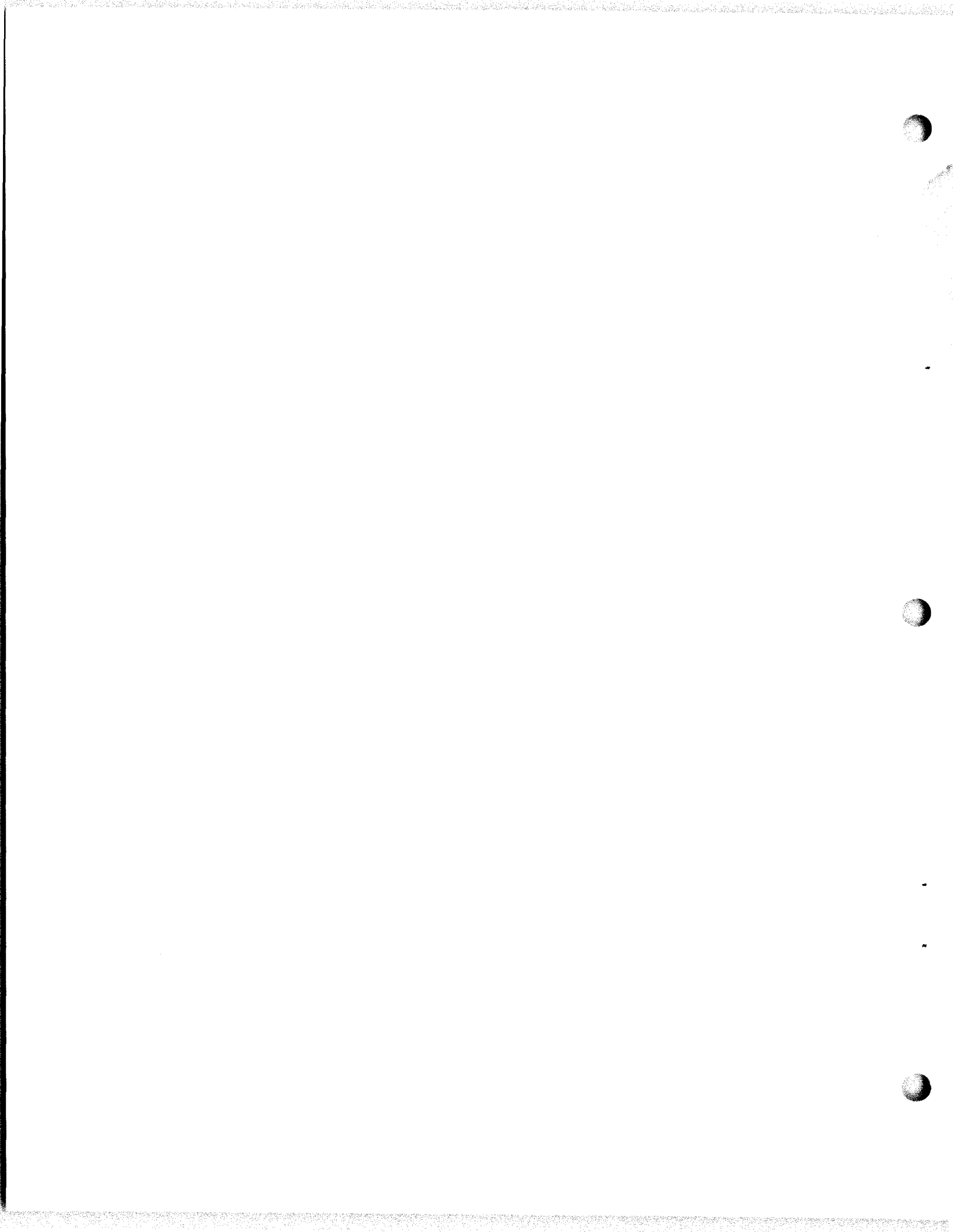

JOB SHEET

FSK TONE GENERATOR and AF AMPLIFIER CIRCUIT VERIFICATION

JOB SHEET NO. 3.1.2.4 1J

INTRODUCTION:

This job sheet will provide hands on experience in adjusting both the FSK tone generator and the AF amplifiers, to verify the modules are functioning correctly. It will involve physically removing modules, performing operational signal tests, and utilizing the functional block diagram in the Student Guide.

These experiences are necessary for a technician to determine the status of these modules. You should also make a physical inspection of the equipment for broken or missing parts.

LESSON TOPIC LEARNING OBJECTIVES:

3.1.2.4.1 IDENTIFY the function of each block in the functional block diagram of the T-827 tone generator by matching the name of each block to the function. Given the block diagram and a list of functions.

3.1.2.4.2 IDENTIFY the amplitude and frequency of signals at specified test points in the T-827 tone generator by selecting the amplitude and frequency of the signal from a list. Given the specified test point and the T-827 technical manual.

3.1.2.4.3 IDENTIFY the function of each part in the T-827 tone generator, given a list of part functions and the T-827 technical manual.

3.1.2.4.4 PERFORM the FSK tone adjustment on the T-827 tone generator. Given a T-827 technical manual, test equipment and a job sheet with procedures specified.

3.1.2.4.5 VERIFY the operational status of the T-827 tone generator by monitoring waveforms and measuring voltages at specified test points and comparing results with technical manual specifications. Given a T-827 technical manual, test equipment, and a job sheet with procedures and test points specified.

3.1.2.4.7 IDENTIFY the amplitude and frequency of signals at specified test points in the T-827 audio amplifiers by selecting the amplitude and frequency of the signals from a list. Given the specified test points and the T-827 technical manual.

3.1.2.4.8 PERFORM the gain adjustment on the T-827 audio amplifier assembly. Given the T-827 technical manual, test equipment and a job sheet with procedures.

3.1.2.4.9 VERIFY the operational status of the T-827 audio amplifiers by monitoring waveforms, and measuring voltages at specified test points and comparing results with technical manual specifications. Given the T-827 technical manual, test equipment, and a job sheet with procedures and test points specified.

3.1.2.4 1J

REFERENCES:

NAVELEC 0967-427-5010 Radio Set AN/WRC-1B Antenna Coupler CU-937/UR Technical Manual

EQUIPMENT and MATERIALS:

- 1- AN/URM-127 Audio Signal Generator
- 1- AN/URT-24B Radio Set
- 1- AN/USM-117 Oscilloscope
- 1- AN/USM-116 VOM
- 1- AN/USM-207 Frequency Counter
- 1- Tool Kit

GENERAL:

Observe all safety precautions.

JOB STEPS:

Step 1. Unscrew the six screws holding the transmitter closed and slide the drawer out until it stops (locks) into position.

Step 2. Turn the AN/URT-24B on to warm up. While the equipment is warming up set the test equipment up properly.

a. The USM-117 settings:

sweep speed: .1 msec/cm
vert. deflect: .5 V/cm
trigger: Int.
input: AC

b. The USM-207 settings:

sensitivity: .1 V
function: Freq.
date time: 1
power: store

c. The USM-116 setting:

function: AC
range: 10 V

NOTE: Zero the meter before the equipment is keyed!

d. The URM-127 setting:

set it to produce 1000 Hz

3.1.2.4 1J

Step 3. The equipment is warmed up, now make the following control settings on the AN/URT-24B:

local remote switch:	local
operating frequency:	8.000 MHz
aux/norm switch:	norm
USB and LSB line level switches:	+10 dB
mode selector switch:	FSK keyed

Step 4. Connect the oscscope to 2A2A9A1TP2.

Step 5. Adjust the output level potentiometer (2A2A9A1R26) for an indication 1 volt peak to peak squarewave.

NOTE: Insure the center frequency switch (S1) is in the 2000 Hz position.

Step 6. Change the center frequency switch to 2550 Hz and observe the signal at 2A2A9A1TP2. Did the signal change? Disconnect the oscscope.

Step 7. Connect the frequency counter to 2A2A9A1TP2. Change the center frequency switch at the 2550 Hz position. Insure the mark/space switch is in the mark position.

Step 8. Adjust 2A2A9A1R13 for an indication of 2125 ± 1 Hz on the frequency counter.

Step 9. Leave the frequency counter connected and the center frequency switch in 2550 Hz position. Change the mark/space switch to the space position.

Step 10. Adjust 2A2A9A1R12 for an indication of $2975 \text{ Hz} \pm 1 \text{ Hz}$.

Step 11. Leaving the counter and the center frequency switch the same, change the mark/space switch back to the mark position. Record your indication displayed on the counter.

Step 12. Leave frequency counter at A1TP2 and the mark/space switch in mark position. Change the center frequency to the 2000 Hz position.

Step 13. Adjust 2A2A9A1R8 for an indication of $1575 \text{ Hz} \pm 1 \text{ Hz}$.

Step 14. Leaving everything the same except for the mark/space switch change it to the space position.

Step 15. Adjust 2A2A9A1R10 for an indication of $2425 \text{ Hz} \pm 1 \text{ Hz}$.

Step 16. Change the mark/space switch to the mark position and record your indication on the frequency counter.

Step 17. Disconnect the frequency counter from 2A2A9A1TP2. Then reconnect the oscscope and record the signal displayed and the peak to peak value.

3.1.2.4 1J

Step 18. Deenergize the transmitter and remove the two AF amplifier modules.

Step 19. Reenergize the transmitter.

Step 20. With the oscope observe and record your findings at the following test points while still in FSK mode of operation.

2A2J18-20 _____

Step 21. Deenergize the transmitter and replace the audio amplifiers.

Step 22. Connect the AN/URT-127 to 2A1J5 and 2A1J6 via a "T" connector.

Step 23. With the AN/URT-127 set for a 1000 Hz set the mode selector switch to the USB mode of operation.

Step 24. Turn the local/remote switch to remote and insure the remote key is set. Tune the audio signal generator for a -17dB deflection on the USB line level meter.

Step 25. Adjust the gain adjust potentiometer 2A2A2A1R11 for an indication of 300 mV peak to peak on the oscilloscope at 2A2A2A1TP2.

Step 26. Turn the mode selector switch to the LSB mode of operation and adjust 2A2A3A1R11 for the proper reading at 2A2A3A1TP2.

What is the indication you should be looking for at 2A2A3A1TP2?

Step 27. Turn the local/remote switch to the local position. Place scope probe at 2A2A3A1TP1.

Step 28. With the mode selector switch in LSB pick up the handset, key it and repeat test 1-2-3, test 1-2-3 while observing the indications on the oscope. Record your indications.

2A2A3A1TP1 _____

3.1.2.4 1J

Step 29. Bring your completed Job Sheet up for the instructor to check your work, before securing the equipment.

Instructor's Signature

Step 30. Secure the position and the equipment the way you found it. Then go back to your seat and complete the self test questions.

SELF TEST ITEMS

1. What is the tolerance on the FSK frequency adjustment?

ASSIGNMENT SHEET 3.1.2.5 1A

T-827 MODE SELECTOR ELECTRONIC ASSEMBLY ANALYSIS

INTRODUCTION

This assignment sheet is comprised of two parts. Part I is designed to give you practice in using a schematic diagram of the TMS, and Technical Manual to obtain information.

Part II is a reading assignment on the circuit description in the AN/WRC-1B technical manual to prepare you for the next lesson. Read the circuit description of the TMS (Transmit Mode Selector) on page 3-35 (par. 3-108) through page 3-36 (par. 3-114).

Lesson Topic Objectives

3.1.2.5.1 IDENTIFY the eight (8) basic circuits employed in the intelligence processing by the T-827 Mode Selector Assembly A2A1, by selecting them from a list of circuits. Given the T-827 Technical Manual.

3.1.2.5.2 IDENTIFY the function of each circuit comprising the T-827 Mode Selector by matching each circuit to a function. Given the T-827 technical manual and a list of functions.

3.1.2.5.3 IDENTIFY the amplitude and frequency of signals as specified test points in the T-827 Mode Selector Assembly by selecting the amplitude and frequency of the signal from a list. Given the specified test point and the T-827 technical manual.

STUDY QUESTIONS: Refer to Homework Handout

Assignment Sheet 3.1.2.6 1A

T-827 IF AMPLIFIER CIRCUIT ANALYSIS

INTRODUCTION:

This assignment sheet is comprised of two parts. Part I is designed to give you practice in using a schematic diagram of the IF Amplifier and the technical manual.

Part II is a reading assignment on the circuit description on the AM-3007/URT to prepare you for the next lesson topic. Read the description on the AM-3007/URT and CU-937/UR starting on page 3-94 (Par. 3-253) through 3-122 (Par. 3-321).

LESSON TOPIC OBJECTIVE(S):

3.1.2.6.1 Given a list of each part in the transmitter IF amplifier assembly, a list of part functions, and the T-827 technical manual, SELECT the function of each part from the list.

3.1.2.6.2 IDENTIFY the amplitude and frequency of signals at specified test points in the T-827 IF Amplifiers by selecting the amplitude and frequency of the signal from a list. Given the specified test point and the T-827 technical manual.

3.1.2.6.3 PERFORM the IF gain adjustment on the T-827 IF Amplifier Assembly. Given a T-827 technical manual, test equipment and a Job Sheet with procedures specified.

3.1.2.6.4 VERIFY the operational status of the T-827 IF Amplifier Assembly by monitoring waveforms and measuring voltages at specified test points and comparing results with technical manual specifications. given a T-827 technical manual, test equipment and a Job Sheet with procedures and test points specified.

STUDY QUESTIONS: Refer to Homework Handout

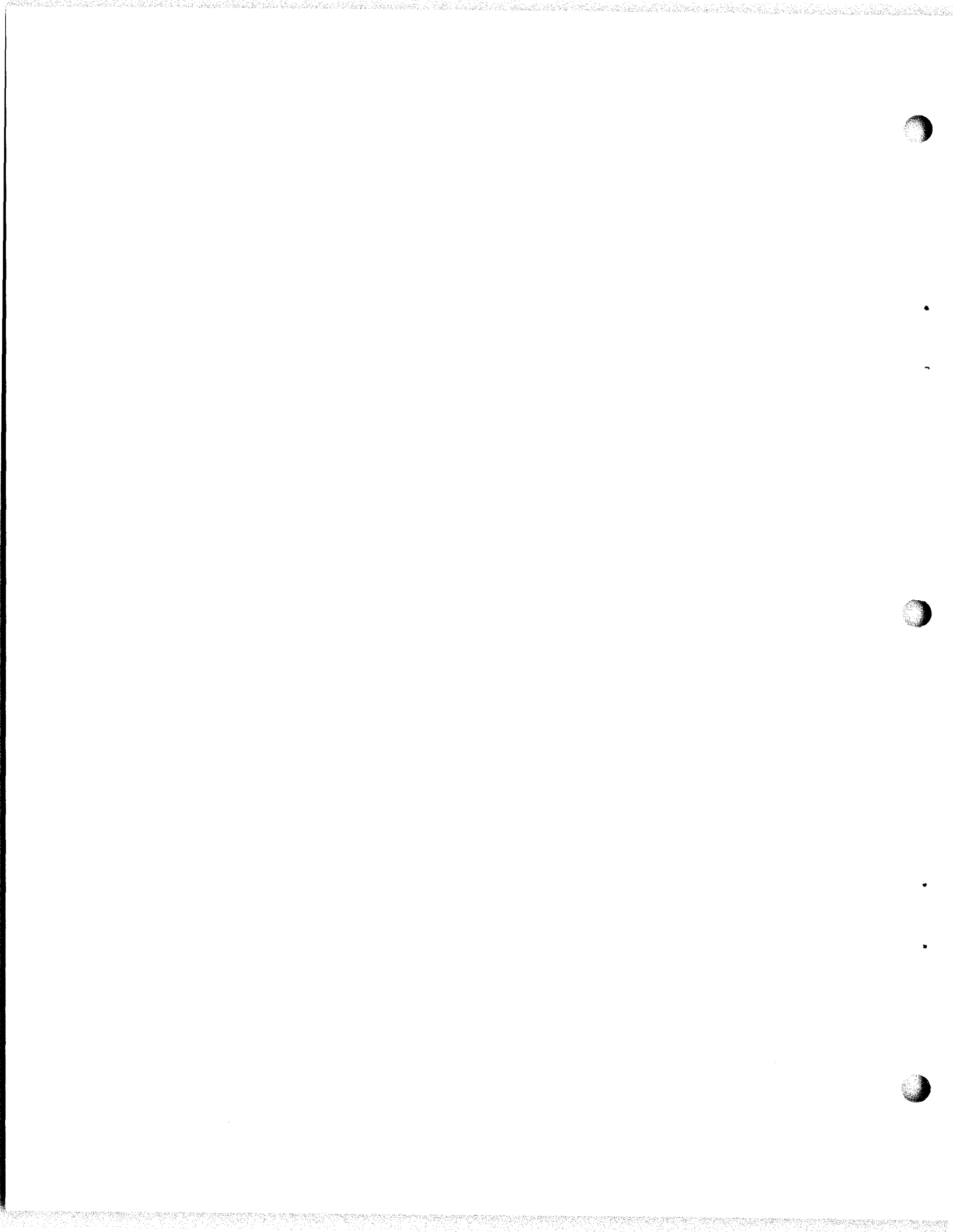

JOB SHEET

TMS AND IF AMPLIFIER ALIGNMENT

Job Sheet 3.1.2.6 1J

INTRODUCTION:

This Job Sheet will provide hands on experience with the TMS and IF amplifier. It will involve performing operational voltage checks and aligning the outputs to the proper signal levels.

You will also make visual inspection of the equipment looking for damages or missing parts.

LESSON TOPIC LEARNING OBJECTIVE(S):

3.1.2.6.3 PERFORM the IF gain adjustment on the T-827 IF Amplifier Assembly. Given a T-827 technical manual, test equipment and a Job Sheet with procedures specified.

3.1.2.6.4 VERIFY the operational status of the T-827 IF Amplifier Assembly by monitoring waveforms and measuring voltages at specified test points and comparing results with technical manual specifications. Given a T-827 technical manual, test equipment and a Job Sheet with procedures and test points specified.

REFERENCES:

NAVELEX 0967-LP-427-5010, Radio Set AN/WRC-1B Antenna Coupler CU-937/UR Technical Manual

EQUIPMENT AND MATERIALS:

1. AN/URT-24B Radio Set (1)
2. AN/USM-117 Oscilloscope (1)
3. Tool Kit (1)

GENERAL:

Observe all safety precautions.

JOB STEPS:

- Step 1. Loosen the six retainer screws and slide the T-827B/URT chassis out till it locks into position.
- Step 2. Defeat the INTERLOCK.
- Step 3. Place the mode selector switch to CW and front panel frequency of 8 MHz (unkeyed at this time).

3.1.2.6 1J

- Step 4. While the transmitter is warming up set your test equipment up.
- Insure a trace is present on the oscilloscope screen.
 - Zero the USM-116 on the AC 10 V scale.
- Step 5. Connect the oscilloscope to 2A2A12A1TP2.
- Step 6. Insert the CW key into 2A1J2.
- Step 7. Adjust the IF GAIN ADJUST control 2A2A12A1R15 for an indication of 57 millivolts peak-to-peak on the oscilloscope. Leave oscilloscope connected.
- Step 8. ADJUST overall transmitter gain by adjusting Xmit Gain ADJ 2A2A4A38R6 for a 2.5 VAC indication on the AN/USM-116.
- Did the signal displayed on the oscilloscope change in amplitude?

- Step 9. Remove the CW key from 2A2J2.
- Step 10. Change the mode selector from CW to AM.
- Step 11. Key the transmitter in either local or remote.
- Step 12. Adjust the PERCENT OF MODULATION ADJ control 2A2A1A4R101 for 1 VAC on the AN/USM 116 deflection.
- Step 13. Unkey the transmitter and rotate the mode selector back to CW. Reinsert the CW key.
- Did the indication on the AN/USM-16 change? _____
 - Did the indication on the oscilloscope change? _____
- Step 14. Unkey the transmitter and place mode selector switch to standby.
- Step 15. Have the instructor verify your work.

Instructor Initial

- Step 16. Secure your lab position and return all equipment and materials to their proper place.

3.1.2.6 1J

SELF-TEST ITEMS:

1. 2A2A1A4R101 does/doesn't effect the LSB or USB modes of operation.
2. Why were you told to use AM rather than CW for the percent of adjust?
3. 2A2A12A1R15 effects the gain of Q3. What other signal is fed to the base of Q3?

ASSIGNMENT SHEET 3.1.2.7 1A

AM-3007/URT AND CU-937/UR BLOCK ANALYSIS

INTRODUCTION:

This assignment sheet is comprised of two parts. Part I is designed to give practice using the Technical Manual and the Functional Block Diagram to obtain information.

Part II is a reading assignment on the AN/WRC-1B System Function Analysis to prepare you for the next lesson.

LESSON TOPIC OBJECTIVE(S):

3.1.2.7.1 IDENTIFY the function of each block in the AM-3007 RF Amplifier block diagram by matching the name of each block to its function, given the block diagram and a list of functions.

3.1.2.7.2 SELECT from a list of statements the energizing source, contact inputs and output distribution paths for each relay in the AM-3007 RF Amplifier. Given the AN/WRC-1 technical manual.

3.1.2.7.3 PERFORM the drive bias, PA bias, and APC adjustments on the AM-3007 RF Amplifier. Given the technical manual, test equipment, tools, and a Job Sheet with procedures specified.

3.1.2.7.4 TEST RF Power output power and transmitter frequencies in accordance with MRC C-304, Q3. Given the technical manual, MRC's, test equipment, tools, and a Job Sheet with procedures specified.

3.1.2.7.5 IDENTIFY the function of each part of the CU-939 Antenna Coupler given a list of part functions and the CU-939 technical manual.

STUDY QUESTIONS: Refer to Homework Handout

JOB SHEET

AM-3007/URT TUNING

JOB SHEET 3.1.2.7 1J

INTRODUCTION:

This job sheet will provide hands on experience in tuning the AM-3007/URT. It will involve making pre-operational control settings.

These experiences are necessary for a technician to determine the status of his equipment. The operational checks will aid in determining if a malfunction exists. Physical inspection is a key element in preventive and corrective maintenance.

LESSON TOPIC LEARNING OBJECTIVE(S):

3.1.2.7.5 PERFORM the drive bias, PA bias, and APC adjustments on the AM-3007 RF Amplifier. Given the technical manual, test equipment, tools, and a Job Sheet with procedures specified.

3.1.2.7.6 TEST RF Power output power and transmitter frequencies in accordance with MRC C-304, Q-3. Given the technical manual, MRC's, test equipment, tools, and a Job Sheet with procedures specified.

REFERENCES:

NAVELEX 0967-LP-427-5020, Radio Set AN/WRC-1B And Antenna Coupler CU-937/UR Technical Manual, Vol. II

NAVELEX 0967-LP-427-5010, Radio Set AN/WRC-1B and Antenna Coupler CU-937/UR Technical Manual, Vol. I

EQUIPMENT AND MATERIALS

1. AN/URT-24B Radio Set (1)
2. Tool Kit (1)

General:

Observe all safety precautions.

JOB STEPS:

PART I: Functional checkout of DC to DC converter assembly.

STEP 1. Loosen retaining screws and withdraw chassis till it locks into position.

3.1.2.7 1J

STEP 2. Make the following settings:

- a. LSB and USB LINE LEVEL MTR switch to +10 dB
- b. Frequency selectors for 8 MHz.
- c. AC/INT Batt switch to AC/INT batt position.
- d. RF output to 100 W forward position.
- e. Primary Power Switch on AM-3007/URT to the ON position.
- f. T-827B Mode Selector to AM.
- g. Install the system it keyes up.
- h. Defeat the AM-3007/URT interlock switch.
- i. CPS/Hz to 000 position.
- j. Local/Remote switch to local.

STEP 3: Using the AN/PSM-4 multimeter take a voltage check at TP-6. This is the input voltage for the A5 assembly. Record your reading.

TP6: _____

3.1.2.7 1J

TABLE 2-4. ANTENNA COUPLER CU-937/UR, TUNING CHART FOR 15-FOOT WHIP ANTENNA

FREQ (MHz)	TUNE	LOAD	FREQ (MHz)	TUNE	LOAD
2.00	7 HI	10 LO	14.00	5 HI	16 LO
2.49	5 LO	12 LO	15.00	3 HI	17 LO
2.50	1 HI	12 LO	15.99	1 HI	16 LO
2.99	6 LO	13 LO	16.00	1 HI	16 LO
3.00	9 HI	12 LO	17.00	0	15 LO
3.49	4 HI	13 LO	17.99	0	15 LO
3.50	4 HI	13 LO	18.00	0	15 LO
3.99	1 HI	14 LO	19.00	1 LO	16 LO
4.00	1 HI	14 LO	19.99	1 LO	16 LO
4.99	4 LO	14 LO	20.00	3 HI	5 LO
5.00	4 LO	14 LO	21.00	1 HI	14 LO
5.99	7 LO	14 LO	21.99	0	14 LO
6.00	12 HI	14 LO	22.00	3 LO	17 LO
6.99	6 HI	14 LO	23.00	3 LO	18 LO
7.00	6 HI	14 LO	23.99	3 LO	18 LO
7.99	0	15 LO	24.00	2 LO	16 LO
8.00	0	15 LO	25.00	3 LO	16 LO
9.00	7 LO	15 LO	25.99	4 LO	18 LO
9.99	12 LO	14 LO	26.00	4 LO	18 LO
10.00	1 HI	15 LO	27.00	4 LO	16 LO
11.00	5 LO	14 LO	27.99	5 LO	17 LO
11.99	5 LO	13 LO	28.00	5 LO	17 LO
12.00	9 HI	16 LO	29.00	6 LO	17 LO
13.00	5 HI	15 LO	29.99	6 LO	18 LO
13.99	1 HI	14 LO			

3.1.2.7 1J

STEP 4. Make the following output checks and record your reading in the space provided.

WARNING

EXERCISE EXTREME CAUTION WHILE MAKING THESE MEASUREMENTS. VOLTAGE AND CURRENT VALUES ARE SUFFICIENT TO BE LETHAL.

CAUTION - CHANGE PSM-4 LEAD TO 100 VDC BEFORE MEASURING PA PLATE.

- a. TP1 = _____
- b. TP2 = _____
- c. TP3 = _____
- d. TP4 = _____
- e. TP5 = _____
- f. TP7 = _____
- g. TP8 = _____

STEP 5. Change the T-827B/URT Mode Selector Switch to USB. Key the T-827B/URT with the handset.

STEP 6. Hold AM-3007/URT amplifier meter switch at DR cath position. Adjust driver bias potentiometer on DC to DC converter until amplifier meter indicates at driver set mark.

STEP 7. Place amplifier meter switch to the PA PL position. Adjust AM/SSB Bias potentiometer on converter until amplifier meter indicates PA set mark.

STEP 8. Disconnect the cable from J6 on the AM-3007/URT. Set T-827B/URT Mode Selector Switch to CW and insure keys are up.

STEP 9. Hold the Amplifier meter switch to the PA PL position. Amplifier meter should indicate at two small (minor) divisions. If necessary, adjust CW/FSK bias potentiometer for this indication.

STEP 10. Reconnect cable to J6. Release slide locks and slide the chassis into case and tighten screws on front panel.

3.1.2.7 1J

PART II: Tuning the AM-3007/URT up.

STEP 1. Locate the tuning chart for the 15 foot whip antenna.

NOTE: This chart is used for course tuning the CU-937/UR. There are three columns (Frequency, Tune, and Load). The tune column relates to the antenna coupler tune control and the load column relates to the antenna coupler load control. The HI relates to pushing the switches up and the LO relates to pushing the switches down. Use 6.99 MHz as an example. With the antenna coupler tune control in the up position, count the flashes of the Antenna Coupler Tune Indicator for six (6) flashes then release the control. Then hold the Antenna Coupler Load Control down for fourteen (14) flashes and release it.

STEP 2. Change the T-827B/URT Mode Selector Switch to USB.

STEP 3. Set the operating frequency for 4.99 MHz.

STEP 4. Do the course tuning as described under the note. This will get you in the frequency range. Set the RF output meter switch to the 100 W Refl. Position.

STEP 5. Hold the Rf output tune/operate switch to tune and minimize indication on RF output meter by adjusting the antenna coupler tune control and the antenna coupler load control. Alternately adjust both controls until indications on RF output meter nulls.

STEP 6. Set the RF output meter switch at 30 W Refl. position.

STEP 7. Repeat Step 5 until meter pointer rests in the smallest black area or to the left of meter scale.

STEP 8. Repeat the above procedure for a Freq(s) of 16 MHz, 3.99 MHz, and 26 MHz. Record your readings in the space provided.

	Refl Power	Fwd Power
3.99 MHz	_____	_____
16 MHz	_____	_____
26 MHz	_____	_____

STEP 9. Have instructor check your Job Sheet and the AM-3007/URT before securing the position.

Instructor Signature

STEP 10. Secure the position and return the tool kit.

3.1.2.7 1J

SELF TEST ITEMS

1. Was the voltage you read at TP8 within tolerance? _____
2. As you changed from AM to FSK what voltages in the AM-3007 changed?

3. What is the purpose of the Tuning Chart?

OVERVIEW

MODULE 3.1.3

AN/WRC-1B

In this module you will learn about the AN/WRC-1B High Frequency Radio Set. You will learn its function and characteristics, how to operate the equipment and finally how to isolate a malfunction to a faulty unit.

The Terminal Objective for this module is:

3.1 ISOLATE a malfunction in the AN/WRC-1B Radio Set to the faulty unit, given the Technical Manual, tools and test equipment. A minimum score of 70% must be achieved based on locating the faulty unit, the procedure, safety and time.

This module consists of one lesson:

3.1.3.1 AN/WRC-1B Familiarization and Operation

ASSIGNMENT SHEET 3.1.3.1 1A

AN/WRC-1B FAMILIARIZATION AND OPERATION

In this lesson you will learn the operating characteristics of the an/WRC-1B Radio Set. You will learn how to operate and adjust it for different modes of operation. You will verify its operational status using front panel indications.

The Enabling Objective(s) for this lesson are:

3.1.3.1.1 Given sets of characteristics identifying frequency range, modes of operation, bandwidth, and power out, SELECT the set which identifies the characteristics of the AN/WRC-1B.

3.1.3.1.2 IDENTIFY the function of each operating control and indicator on the AN/WRC-1B by selecting from a list of functional descriptions.

3.1.3.1.3 TUNE/OPERATE the AN/WRC-1B when given the equipment technical manual and a Job Sheet specifying the procedure.

3.1.3.1.4 VERIFY the operational status of the AN/WRC-1B when given the equipment manual and a Job Sheet specifying the procedure.

3.1.3.1.5 ISOLATE a malfunction of the AN/WRC-1B to the faulty unit using front panel indications when given the equipment technical manual and a Job Sheet specifying procedures.

STUDY ASSIGNMENT: None

STUDY QUESTIONS: None

JOB SHEET

AN/WRC-1B FAMILIARIZATION AND OPERATION

Job Sheet No. 3.1.3.1 1J

INTRODUCTION:

This job sheet will provide hands on experience in checking out a system including all the equipment taught these last two weeks combined together. It will involve physically removing modules, performing operational signal tests, and utilizing the functional block diagram in your Student Guides.

These experiences are necessary for a technician to determine the status of the system. You will also make some physical inspections.

LESSON TOPIC LEARNING OBJECTIVES:

3.1.3.1.1 Given sets of characteristics identifying frequency range, modes of operation, bandwidth, and power out, SELECT the set which identifies the characteristics of AN/WRC-1B.

3.1.3.1.2 IDENTIFY the function of each operating control and indicator on the AN/WRC-1B by selecting from a list of functional descriptions.

3.1.3.1.3 TEST/OPERATE the AN/WRC-1B when given the equipment technical manual with a job sheet specifying the procedure.

3.1.3.1.4 VERIFY the operational status of the AN/WRC-1B when given the equipment technical manual and a job sheet specifying the procedure.

3.1.3.1.5 ISOLATE a malfunction of the AN/WRC-1B to the faulty unit using front panel indications when given the equipment technical manual and a job sheet specifying procedures.

REFERENCES:

1. NAVELEX 0967-LP-427-5010 Radio Set AN/WRC-1B and Antenna Coupler CU-937/UR, Vol I Technical Manual.
2. NAVELEX 0967-LP-427-5020 Radio Set AN/WRC-1B and Antenna Coupler CU-937/UR, Vol II Technical Manual

EQUIPMENT AND MATERIALS:

1. AN/WRC-1B Radio Set (1)
2. AN/USM-117 Oscilloscope (1)
3. AN/URM-25D RF Signal Generator (1)
4. AN/USM-127 AF Signal Generator (1)
5. AN/USM-207 Frequency Counter (1)
6. AN/USM-116 Multimeter (1)
7. Tool Kit (1)

3.1.3.1 1J

GENERAL:

Observe all safety precautions.

NOTE: This the check out procedure for the WRC-1B for our lab conditions only.

STEP 1. Check the main position bulkhead circuit breaker, should be on.

STEP 2. Check out the operating controls for the AM-3007/URT.

- a. Check the primary power breaker switch (3A2A1CB1), should be on.
- b. Check the fuse indicators (3A2A1XF1 & 3A2A1XF2), see if they are lit. (if so contact the lab instructor)
- c. Check the primary power indicator (3A2A1DS1), should be lit.
- d. Check the primary power selector switch (3A2A1S2), should be in the ac/int position.

STEP 3. Check out the operating controls for the T-827B/URT.

- a. Check the remote/local switch (2A2S1), should be local.
- b. Turn the mode selector switch (2A2S2) to LSB.
- c. Check the fuse indicators (2A2DS1 & 2A2DS2) see if they are lit (if so contact the lab instructor).
- d. Turn the mode selector switch (2A2S2) back to standby.
- e. Check the line level switches (2A2S10 & 2A2S11), should be in the -10dB position.
- f. Check the frequency dialed up on the front panel, should read 8 MHz.
- g. Check the cps switch (2A2S6), should be in the 000 position.
- h. Slide the T-827B/URT drawer open and check the aux/norm, should be in the norm position then slide the drawer closed.

STEP 4. Check out the operating controls for the R-1051B/URT.

- a. Turn the mode selector switch (1A2S2) to LSB.
- b. Check the fuse indicators (1A2DS1 & 1A2DS2) see if they are lit (if so contact the lab instructor).
- c. Turn the mode selector switch (1A2S2) back to standby.

3.1.3.1 1J

- d. Check the line level switches (1A2S1 & 1A2S5), should be in the +20dB position.
- e. Turn the line level controls (1A2R2, 1A2R12, 1A2R1, & 1A2R11) both located below the line level switches, turn them fully CW.
- f. Turn both phone level controls (1A2R4 & 1A2R5) fully CW.
- g. Turn the RF gain control (1A2R3) fully CW.
- h. Check the frequency dialed up on the front panel, it should read 8MHz.
- i. Check the cps switch (1A2S6), should be in the 000 position.
- j. Slide the R-1051B/URT drawer open and check the aux/norm switch (1A2S7), should be in the norm position.
- k. Check the simplex/duplex switch (1A2S9), should be in the simplex position. Now close the drawer.

STEP 5. Turn the mode selector switch 1A2S2 to LSB. What indications are noted about the following items?

- a. Listening to handset is there anything present? _____
- b. LSB L.L. Meter _____
- c. USB L.L. Meter _____
- d. AN/USM 116 _____

NOTE: Place mode selector switch in standby.

STEP 6. Connect the AN/URM-25D to 1A1J23.

STEP 7. Set up the AN/URM-25 the way you did in the R-1051B for check out procedure.

STEP 8. List the indications noted on the following: With the mode selector (1A2S2) in USB.

- a. Audio in the handset or noise _____
- b. LSB L.L. Meter (1A2M1) _____
- c. USB L.L. Meter (1A2M2) _____
- d. AN/USM-116 Deflection _____

3.1.3.1 1J

STEP 9. List the indications noted on the following with both mode selectors 1A2S2 and 2A2S2 in LSB.

- a. Audio in Handset _____
- b. LSB L.L. Meter (1A2M1) _____
- c. LSB L.L. Meter (2A2M1) _____
- d. USB L.L. Meter (1A2M2) _____
- e. USB L.L. Meter (2A2M2) _____
- f. AN/USM-116 Deflection _____

STEP 10. Key the handset in USB. Does the audio go away? _____
yes/no.

If so why? _____

STEP 11. With the handset still in LSB and keyed, talk into the handset and list indications ask for.

- a. Audio in Handset _____
- b. LSB L.L. Meter (1A2M1) _____
- c. LSB L.L. Meter (1A2M2) _____
- d. USB L.L. Meter (2A2M1) _____
- e. USB L.L. Meter (2A2M2) _____
- f. AN/USM-116 Deflection _____

3.1.3.1 1J

STEP 12. Change the mode selectors (1A2S2 and 2A2S2) to AM and list the indications without keying the handset.

- a. Audio in Handset _____
- b. LSB L.L. Meter (1A2M1) _____
- c. LSB L.L. Meter (2A2M1) _____
- d. USB L.L. Meter (1A2M2) _____
- e. USB L.L. Meter (2A2M2) _____
- f. AN/USM-116 Deflection _____

STEP 13. Key the handset in AM without talking into it. List your indications.

- a. Audio in Handset _____
- b. LSB L.L. Meter (1A2M1) _____
- c. LSB L.L. Meter (2A2M1) _____
- d. USB L.L. Meter (1A2M2) _____
- e. USB L.L. Meter (2A2M2) _____
- f. AN/USM-116 Deflection _____

STEP 14. Key the handset in AM and modulate into it. List your indications.

- a. Audio in Handset _____
- b. LSB L.L. Meter (1A2M1) _____
- c. LSB L.L. Meter (2A2M1) _____
- d. USB L.L. Meter (1A2M2) _____
- e. USB L.L. Meter (2A2M2) _____
- f. AN/USM-116 Deflection _____

3.1.3.1 1J

STEP 15. Change the mode selector switches 1A2S2 & 2A2S2 to CW and list indication without the CW key inserted.

- a. Audio in the Handset _____
- b. LSB L.L. Meter (1A2M1) _____
- c. LSB L.L. Meter (2A2M1) _____
- d. USB L.L. Meter (1A2M2) _____
- e. USB L.L. Meter (2A2M2) _____
- f. AN/USM-116 Deflection _____

STEP 16. Insert the CW key into the proper jack leaving the mode selector switches still in CW and list the indication below.

- a. Audio in the Handset _____
- b. LSB L.L. Meter (1A2M1) _____
- c. LSB L.L. Meter (2A2M1) _____
- d. USB L.L. Meter (1A2M2) _____
- e. USB L.L. Meter (2A2M2) _____
- f. AN/USM-116 Deflection _____

STEP 17: Bring your completed Job Sheet up for the instructor to check your work before securing the equipment.

Instructor's Signature

STEP 18. Secure the position and the equipment the way you found it. Then go back to your seat and review what you did.

OVERVIEW

MODULE 3.1.4

AN/URT-23 AND AN/URA-38

In this module you will learn the general characteristics of and physically adjust the AN/URT-23 transmitter and the AN/URA-38 antenna coupler. You will learn the function of many circuits which were not previously covered in the common components that made up the AN/WRC-1B. You will learn to trace the AC and DC voltage distribution with less emphasis on signal paths as these were previously covered during your study of the AN/WRC-1B. You will learn to trace these paths using block and schematic diagrams normally found in the technical manuals and physically locating test points and measuring these voltages. You will perform tests and troubleshoot faulty power distribution and control circuits of the AN/URT-23.

The Terminal Objective of this module is:

3.4 ISOLATE a malfunction in the primary power distribution and control circuits of the AN/URT-23 Radio Transmitter to the faulty part. Given the equipment technical manual, tools, and test equipment. A minimum score of 70% must be achieved based on locating the faulty part, in allotted time, compliance with a prescribed logical troubleshooting procedure and safety.

This module is divided into five lessons:

Lesson 3.1.4.1 AN/URT-23 and AN/URA-38 Familiarization and Operation

Lesson 3.1.4.2 AN/URT-23 and AN/URA-38 Primary Power Circuit Analysis

*Lesson 3.1.4.3 AN/URT-23 and AN/URA-38 Tuning Circuit Analysis (Deleted)

Lesson 3.1.4.4 AN/URT-23 and AN/URA-38 Main Signal Path Analysis

Lesson 3.1.4.5 AN/URT-23 and AN/URA-38 Control Circuit Analysis

Lesson 3.1.4.6 AN/URA-38 Functional Block Diagram Analysis

*Deleted (combined with 3.1.4.5)

AN/URT-23/URA-38 OPERATIONAL FAMILIARIZATION

INTRODUCTION

The main prerequisite for becoming proficient in the maintenance of the AN/URT-23(V) is a thorough knowledge of the operating procedures. In addition, a thorough knowledge of the location and identification of all units and subunits will greatly enhance your skill. This assignment sheet checks your knowledge and understanding of these facts. Satisfactory completion of this assignment will indicate that you have gained sufficient knowledge of the system to begin your study of the circuitry involved in the AN/URT-23(V).

LESSON TOPIC OBJECTIVE(S)

3.1.4.1.1 Given sets of characteristics identifying frequency, range, modes of operation, bandwidth, power out and distortion, SELECT the set which identifies the characteristics of the AN/URT-23.

3.1.4.1.2 IDENTIFY the function of each operating control and indicator on the AN/URT-23 and AN/URA-38 by selecting from a list of functional descriptions.

3.1.4.1.3 TEST/OPERATE the AN/URT-23 and AN/URA-38 in accordance with MRC C-304, M2. Given the equipment technical manuals and a Job Sheet.

3.1.4.1.4 VERIFY the operational status of the AN/URT-23 in accordance with MRC C304, M2. Given the equipment technical manuals and a Job Sheet.

STUDY QUESTIONS: Refer to Homework Handout

3.1.4.2 1N

	2A3B1	AN/URA-38 2A1DS2	3A2A13 DS3 & DS4	2A1DS1	1A1B1	
ON						
OFF						
	1A1DS2	1A1B2 W/FMM	3A2A4B1 W/FMM	1A1DS3	M P M	1A1DS5
ON						
OFF						

WILL NOT COMPLETE-----

	2A3B1	AN/URA-38 2A1DS2	3A2A13 DS3 & DS4	2A1DS1	1A1B1	
ON						
OFF						
	1A1DS2	1A1B2 W/FMM	3A2A4B1 W/FMM	1A1DS3	M P M	1A1DS5
ON						
OFF						

WILL NOT COMPLETE-----

	2A3B1	AN/URA-38 2A1DS2	3A2A13 DS3 & DS4	2A1DS1	1A1B1	
ON						
OFF						
	1A1DS2	1A1B2 W/FMM	3A2A4B1 W/FMM	1A1DS3	M P M	1A1DS5
ON						
OFF						

WILL NOT COMPLETE-----

*STEP2/URT

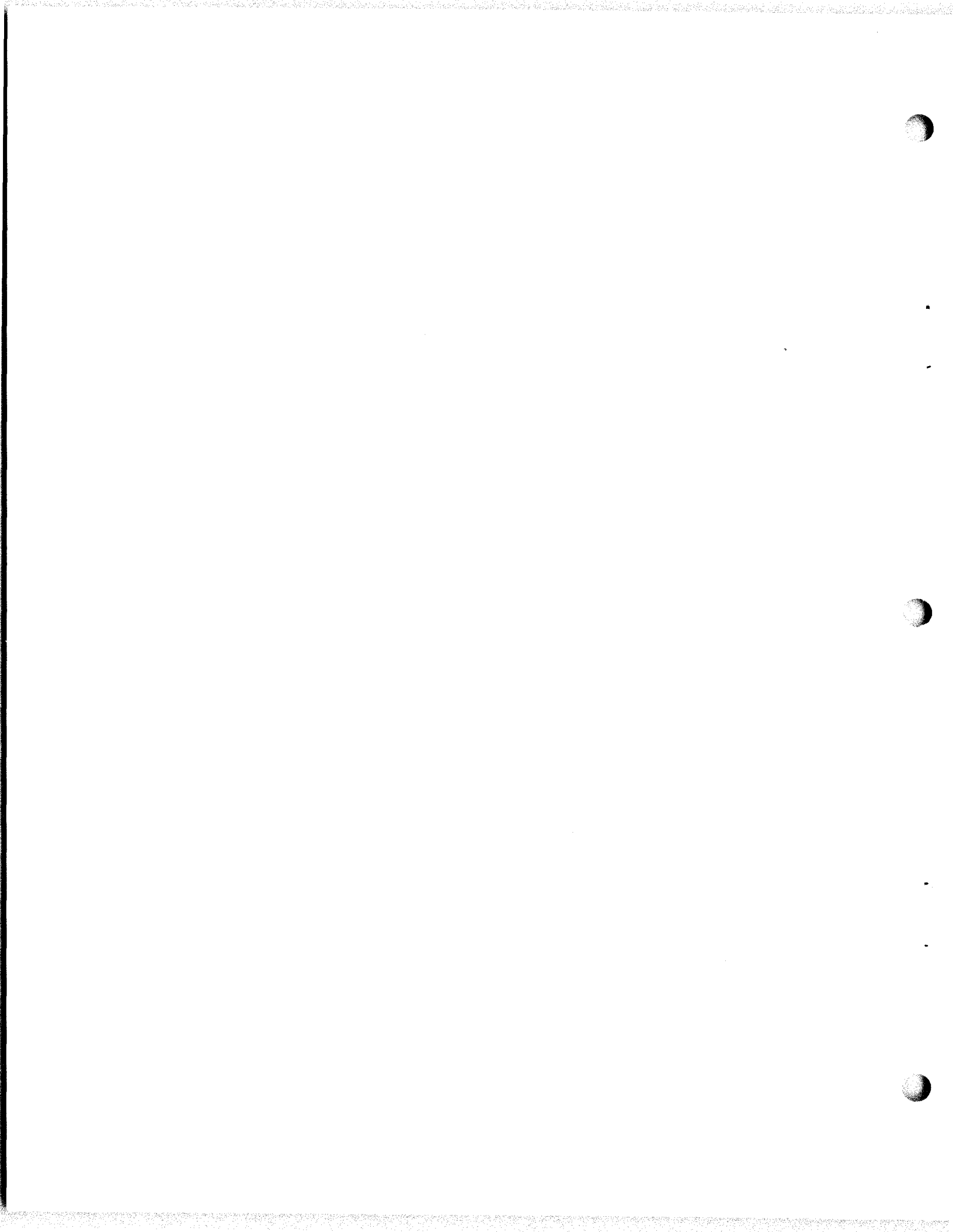

JOB SHEET

AN/URT-23, AN/URA-38 OPERATIONAL FAMILIARIZATION

JOB SHEET NO. 3.1.4.2 1J

INTRODUCTION:

As a maintenance technician, you will find there is more to "operating" the AN/URT-23 than simply being familiar with the controls and indicators, and manipulating them to set up the equipment. Front panel controls and indicators can serve as build-in test equipment for the technician who knows how to use them and interpret their indications. This is often a great time-saver while troubleshooting the equipment. Before you can do this, however, you must be capable of operating the equipment proficiently. Part I of this Job Sheet is designed to help you do so.

Part II of this Job Sheet will help you become familiar with the interior of the AN/URT-23(V) so that you will be able to find sub-units, modules or major parts as required during maintenance.

This Job Sheet will aid you, the technician, to more rapidly isolate the obvious as well as the not so obvious troubles which occur within the primary power portion of the AN/URT-23(V) Radio Transmitting Set. You are required to locate and trace-out all AC voltages as well as all DC voltages supplied by the various power supplies incorporated within the AN/URT-23(V) Radio Transmitting Set, utilizing the appropriate schematic, technical manual(s), actual equipment, and test equipment required.

This term we have labeled as "Primary Power", refers to applying AC voltages to the primaries of the transformers. The secondaries will have their appropriate voltages which are distributed to associated power supplies, filaments, and screen/plate circuits.

The energizing of the AN/URT-23(V) Radio Set is accomplished in three levels of operation. They are: (1) INITIAL TURN-ON, (2) STANDBY, and (3) OPERATE. During each of the three levels of operation, voltages can be predicted at the primaries and the power supply outputs throughout the AN/URT-23(V) Radio Transmitting Set.

LESSON TOPIC OBJECTIVES:

- 3.1.4.1.3 TEST/OPERATE the AN/URT-23 and AN/URA-38, given the equipment, technical manuals and a Job Sheet.
- 3.1.4.1.4 VERIFY the operational status of the AN/URT-23, given the equipment, technical manuals and a Job Sheet.
- 3.1.4.2.3 LOCATE circuitry, test points, and parts which comprise the power distribution system of the AN/URT-23 and AN/URA-38 when given the technical manuals for the equipments and a Job Sheet.

EQUIPMENT AND MATERIALS:

1. AN/URT-23(V)
2. AN/PSM-4 Multimeter
3. Six-inch screwdrivers

Before starting to work on the equipment, READ and HEED the following safety rules; they have withstood the test of time, and if you follow them YOUR chances of doing well be greatly improved.

1. Personnel Safety

- a. NEVER work on equipment ALONE.
- b. DO NOT make voltage or waveform checks haphazardly. The voltages present may be dangerous to life and limb.
- c. DO NOT check high voltages except where first specified, and in all cases, read instructions carefully first.
- d. BE SURE that all equipment and test equipment is grounded.
- e. BE SURE the surface on which you are standing is DRY.
- f. Familiarize yourself with latest methods of electrical shock treatment (including artificial respiration).
- g. ALWAYS use the correct tools.
- h. Be extremely CAREFUL when making measurements or adjustments in the power supplies.
- i. NEVER become involved in horseplay while near the equipment.

2. Equipment Safety

- a. Keep equipment clean and dry; refer to maintenance manual before cleaning, oiling, or refurbishing.
- b. DO NOT allow equipment to be set in a precarious position.
- c. ALWAYS refer to maintenance procedures BEFORE making an alignment or adjustment.

ABOVE ALL ELSE, USE COMMON SENSE, AND WHEN EVERYTHING ELSE FAILS, FOLLOW DIRECTIONS.

REFERENCES:

NAVELEX 0967-LP-879-5010, Radio Transmitting Set AN/URT-23(V) Technical Manual

JOB STEPS:

PART I: Set up and test operation of the transmitter and antenna coupler.

1. If all items on the Equipment and Materials list are present, proceed with Step 2. If not, inform your instructor.
2. Ensure that the bulkhead switch is OFF, then make the following preliminary settings on the equipment.
 - a. On the T-827B/URT
 - (1) Mode selector switch to OFF.
 - (1A) Freq to 12 MHZ.
 - (2) Local/Remote switch to LOCAL.
 - (3) Aux/Norm switch to NORM.
 - (4) Interlock pulled up.
 - b. On the AM-6909(P)/URT
 - (1) Primary power switch to OFF.
 - (1A) Interlock (on case) pulled out.
 - (2) Overload switch to ALARM.
 - (3) Key switch to NORMAL.
 - (4) Frequency band selector switch to AUTO.
 - (5) Multipurpose meter switch to INPUT PWR.
 - (6) Set AM-6909 PWR control to maximum clockwise position.
 - (7) Set AM-6909 PA BIAS control to maximum counter-clockwise position.
 - c. On the C-3698/URA
 - (1) Overload switch to ALARM.
 - (2) Power switch to OFF.
 - (3) Mode selector switch to MANUAL.
 - d. Check snugness of front panel screws near interlocks. (This ensures that interlocks are engaged.)

3. Energizing the equipment.

- a. Turn the bulkhead switch on.
- b. Set primary power switch on the AM-6909(P) to ON.
 - (1) PP-3916 blower motor should energize.
- c. Set the AN/URA-38 power switch to ON.
 - (1) Power indicator lamp should light.
- d. Set the T-827 mode selector switch to STBY and note the time _____. The following will take place:
 - (1) AM-6909(P) blower motor will energize.
 - (2) AM-6909(P) standby indicator lamp will light.
 - (3) PP-3916/UR power indicator lamp will light.
 - (4) T-827 dial indicator lamps will light.
 - (5) C-3698 Bypass lamp will light.
 - (6) AM-6909(P) band select motor should turn when a frequency mismatch is generated.
- e. The thermal time delay relay located within the AM-6909(P)/URT was initiated when the T-827 mode selector switch was placed in STDBY. It will be approximately three minutes before its contacts will close and the system becomes operational. While you are waiting for the time delay to close, perform the following of the C-3698:
 - (1) Check the tuning element movement.
 - (a) Place the L-C switch to the "c" position. Move "C" element to its far end stop by depressing the RIGHT push-button until the meter movement stops. Record the meter reading. _____
(approx 5)
 - (b) Place the L-C switch to the "L" position and repeat Step 3.e.(2)(a) for the "L" element. _____
(approx 9)
 - (c) Both tuning elements are now at their far end stop positions. For equipment safety, move both tuning elements off their far end stop positions. Do this by using the L-C switch, ("C" position first and "L" position next), and depressing the LEFT push-button until the element position meter reads approximately "2" for each position of the L-C switch.
- f. Set the T-827B/URT mode selector to LSB. Check time noted in Step 3.d. Three minutes should have elapsed. If so, the time delay contacts have closed and the following indications should be present:
 - (1) AM-6909(P)/URT Standby lamp should extinguish.

(2) AM-6909(P)/URT Operate lamp should light.

(3) T-827 Turret should turn when a frequency mismatch is generated.

g. Check and record multipurpose meter readings on the AM-6909(P)/URT.

METER SWITCH POSITION	METER READING
(1) PA DRIVER SCRNS	_____ (290+50 VDC)
(2) DRIVER PLATE VOLTS	_____ (500+75 VDC)
(3) PA PLATE VOLTS	_____ (2250+225 VDC)

W A R N I N G

PLATE CURRENTS IN EXCESS OF 330 mA WILL DAMAGE THE AM-6909(P)/URT FINAL AMPLIFIER TUBES. DO NOT KEY THE TRANSMITTER FOR LONG PERIODS UNTIL THE PA BIAS IS PROPERLY ADJUSTED.

(4) Set key switch to LOCAL KEY, and continue taking meter readings.

METER SWITCH POSITION	METER READING
(5) PA PLATE 1 AMPERES	_____
(6) PA PLATE 2 AMPERES	_____

h. Compare the reading obtained in Steps 3.g.(5) and 3.g.(6). Set multipurpose meter switch to the position which indicated the lower reading, and carefully rotate the PA BIAS control 1A1R10 to obtain a reading of 240 mA.

i. Set the multipurpose meter switch to the other plate position and check reading. It should not exceed 280 mA.

j. Adjust driver currents, rotate DR bias control 1A1R9.

METER SWITCH POSITION	METER READING
(1) DRIVER 1	_____
(2) DRIVER 2	_____

Lower reading should be 320 mA.
High reading should not exceed 400 mA.

k. Return key switch to NORMAL.

l. Return multipurpose meter switch to INPUT PWR.

Ask your instructor to check your work.

INSTRUCTOR'S INITIALS: _____

Part II: Identification and Location of Sub-Units, Modules, and Terminal Boards.

JOB STEPS

1. Record all predictions for INITIAL TURN ON, STANDBY, and OPERATE.
 - a. Predict all front panel indications listed in CHART I by indicating ON or OFF.
 - b. Predict the value as well as type of voltage listed in CHART II.
 - c. Complete the predictions for CHART III (STANDBY) and CHART IV (OPERATE, LSB MODE, and Normal-Local-Tune Key on AM-6909 in ~~LSB~~ NORMAL).
2. Have instructor check your predictions _____.
3. INITIAL TURN ON
 - a. Energize Bulkhead Switch
 - b. Place AM-6909 Primary Power Switch (1A1S4) and AN/URA-38 Power Switch (2A1S7) ON.

NOTE: For the next two steps utilize the actual column for Initial Turn On ONLY.

- c. Record the front panel indications in CHART I.
 - d. Measure and record all test locations listed in CHART II.
4. STANDBY

- a. Place the T-827 Mode Selector Switch in STANDBY.

NOTE: For the next two steps utilize the actual column for Standby ONLY.

- b. Record all front panel indication in CHART I.
- c. Measure and record all test locations in CHART II.
- d. Record the following test readings utilizing the Multipurpose meter on the front panel of the AM-6909.
- e. Locate and identify relay 1A1K2.

QUESTION: From the information obtained in CHART II, what voltage energizes 1A1K2 and where does it come from?

+28VDC 3A2-E22

QUESTION: Rotate the MHZ control knob at least on position below present setting and observe the Turret and Band Select Motors.

- | | | | |
|-------------|--------|------------|-----------|
| (1) T-827 | Rotate | YES | <u>NO</u> |
| (2) AM-6909 | Rotate | <u>YES</u> | NO |

INITIAL TURN ON STANDBY OPERATE

		PRED.	ACTUAL	PRED.	ACTUAL	PRED.	ACTUAL
Power on Lamp	AN/URA-38	ON		ON		ON	
Power on Lamp	PP-3916	OFF		ON		ON	
Blower Motor	PP-3916	ON		ON		ON	
Blower Motor	AM-6909	OFF		ON		ON	
Standby Lamp	AM-6909	OFF		ON		OFF	
Operate Lamp	AM-6909	OFF		OFF		ON	
Band Select Motor	AM-6909	OFF		ON		ON	
Dial Lamps	T-827	OFF		ON		ON	
Turret Motor	T-827	OFF		OFF		ON	

CHART II

2A2TB1 - 22 TO 23	208		208		208
2A1TB1 - 10 TO 13	225		225		225
1A1TB2 - 3 TO 4	115		115		115
1A1TB5 - 3 TO 4	208		208		208
1A1TB4 - 1 TO 13	208 0		208		208
2A1TB1 - 16 TO GND	25		0		0
1A1TB1 - 6 TO GND	28 0		28		28
1A1A5TP1 to GND	0		11		11
URA-38 2A1A3TP1 TO GND	28		28		28
3A2E22 TO GND	0		28		28
3A2E24 TO GND	0		0		20
3A2E9 TO GND	0		110		110

(Use the appropriate circuit board extender for the next two measurements. Use pages 40-G and 40-F in Volume 3 for voltage references.)

1A1A5P1 - U to Ground	0		0		+20
1A1A6P1 - A to Ground	0		-160		-160

CHART III

	PREDICTED	ACTUAL
Position #1		
Position #2		
Position #3		
Position #4		
Position #5		
Position #6		
Position #7		
Position #8		

5. OPERATE

- a. Locate and name 1A1K1 OPERATE RELAY
- b. Place the Mode Selector Switch in LSB and listen to 1A1K1.
- c. Record the front panel indications in CHART I.
- d. Measure and record all test locations in CHART II.
- e. Measure and record the following test readings utilizing the Multipurpose Meter on the front panel of the AM-6909. Place 1A1S3 in LOCAL.

CHART IV

	<u>PREDICTED</u>	<u>ACTUAL</u>
(1) DRIVER 2	 	
(2) DRIVER 1	 	
(3) PA Plate 2	 	
(4) PA Plate 1	 	
(5) Input Power	<i>0W</i>	<i>0W</i>
(6) PA Plate	<i>2250 VDC</i>	<i>2300 VDC</i>
(7) Driver Plate	<i>500 VDC</i>	<i>570 VDC</i>
(8) PA & Driver Screens	<i>287 VDC</i>	<i>300 VDC</i>

QUESTION: How does the voltage that appears at 3A2E24 cause the Operate Relay (1A1K1) to energize?

6. Place the Mode Selector Switch to USB. Open the PP-3916 door and defeat three interlocks.
7. Push interlock switch 2A1S4 in and release. Explain the results.
8. DEENERGIZE AND SECURE ALL EQUIPMENT.

AN/URT-23 equipment shutdown.

NOTE: For emergency shutdown only, set the AM-6909 primary power switch directly to OFF. For normal shutdown, use the following procedure:

- a. Set the T-827B MODE SELECTOR switch of STDBY.
- b. Set the AN/URA-38 POWER switch to OFF.
- c. After equipment has cooled for 3 minutes, set T-827 Mode Selector switch to OFF.
- d. Set the AM-6909 PRIMARY POWER switch to OFF.
- e. Bulkhead switch set to OFF.
- f. Place equipment in OFF condition, and properly stow test equipment, tools, and material. Report to Lab Supervisor.

SELF-TEST ITEMS:

1. After lighting off the AN/URT-23, how much time should be allowed prior to attempting to operate the transmitter?
2. Why should the AN/URT-23 be placed in STANDBY if the equipment is to be shut down for only a short time?
3. Which mode selector switch contacts initiate STANDBY?
4. Which mode selector switch contacts initiate OPERATE?
5. Refer to AN/URT-23 Technical Manual, pages 2-10 through 2-18 and physically locate all interconnecting cables on the AN/URT-23.
6. Refer to AC-DC power distribution schematic, page 35 Vol. 3, and utilizing the information found in Step 10, make entries on the schematic. (W-1, W-2, W-3, etc....)

NOTE: Notify your instructor when you have completed the Job Sheet.

Date _____

Instructor's Initials _____

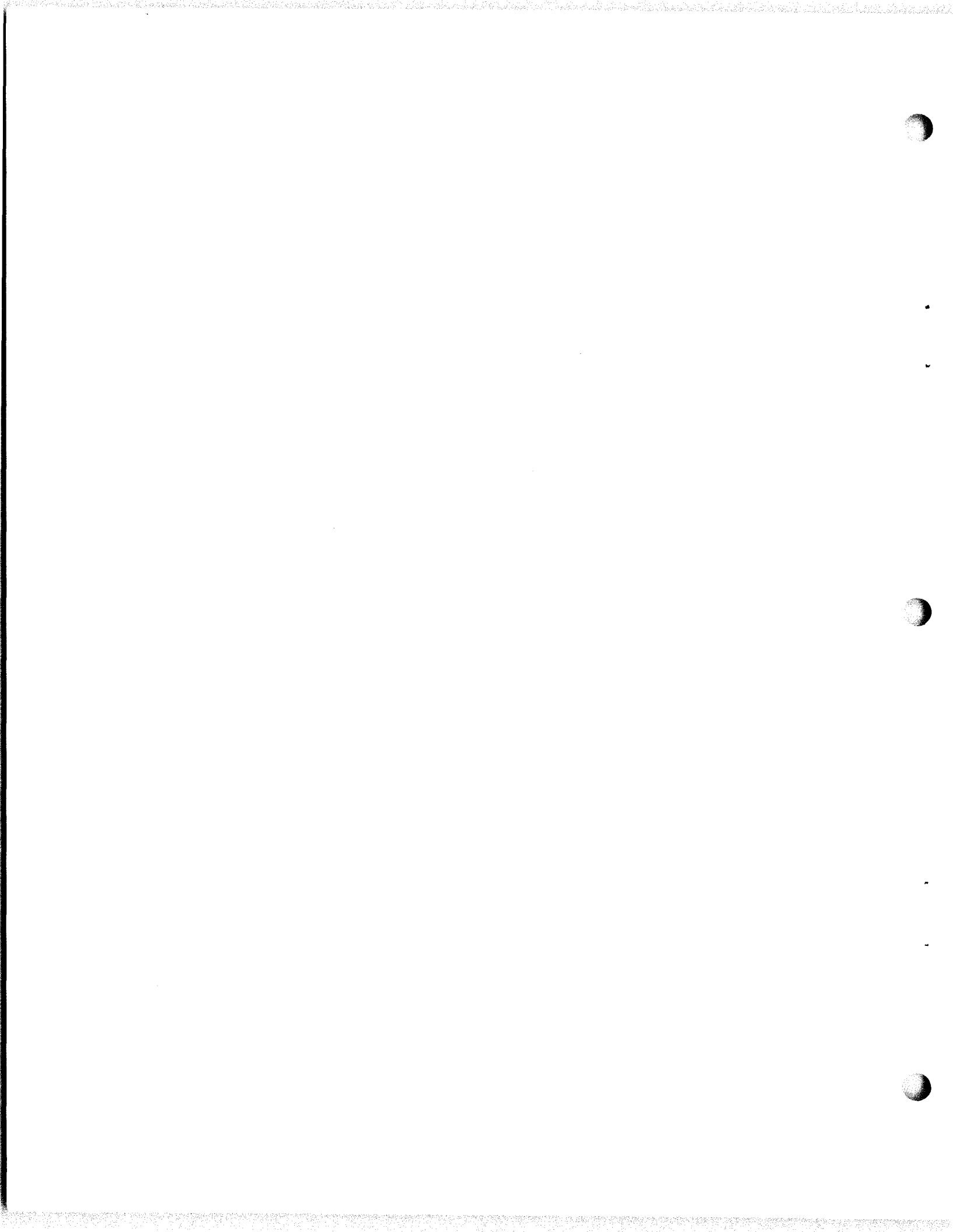

MAIN SIGNAL PATH THROUGH AM-6909

INTRODUCTION

In this lesson you will learn how the RF signal is amplified and controlled as it is processed from the T-827/URT through the AM-6909 RF amplifier and the AN/URA-38 antenna coupler to the transmitting antenna. You will learn the points on the signal path where control and metering circuits are located.

LESSON TOPIC OBJECTIVE(S)

3.1.4.4.1 IDENTIFY the signal conversions accomplished at specified points in the main signal path of the AN/URT-23 and AN/URA-38 by selecting from a list of conversion statements. Given the equipment technical manual.

3.1.4.4.2 IDENTIFY the metering circuit path for specified indications in the AN/URT-23 by selecting from a list of circuit path descriptions. Given the equipment technical manual, a meter indication and mode of operation.

STUDY QUESTIONS: Refer to Homework Handout

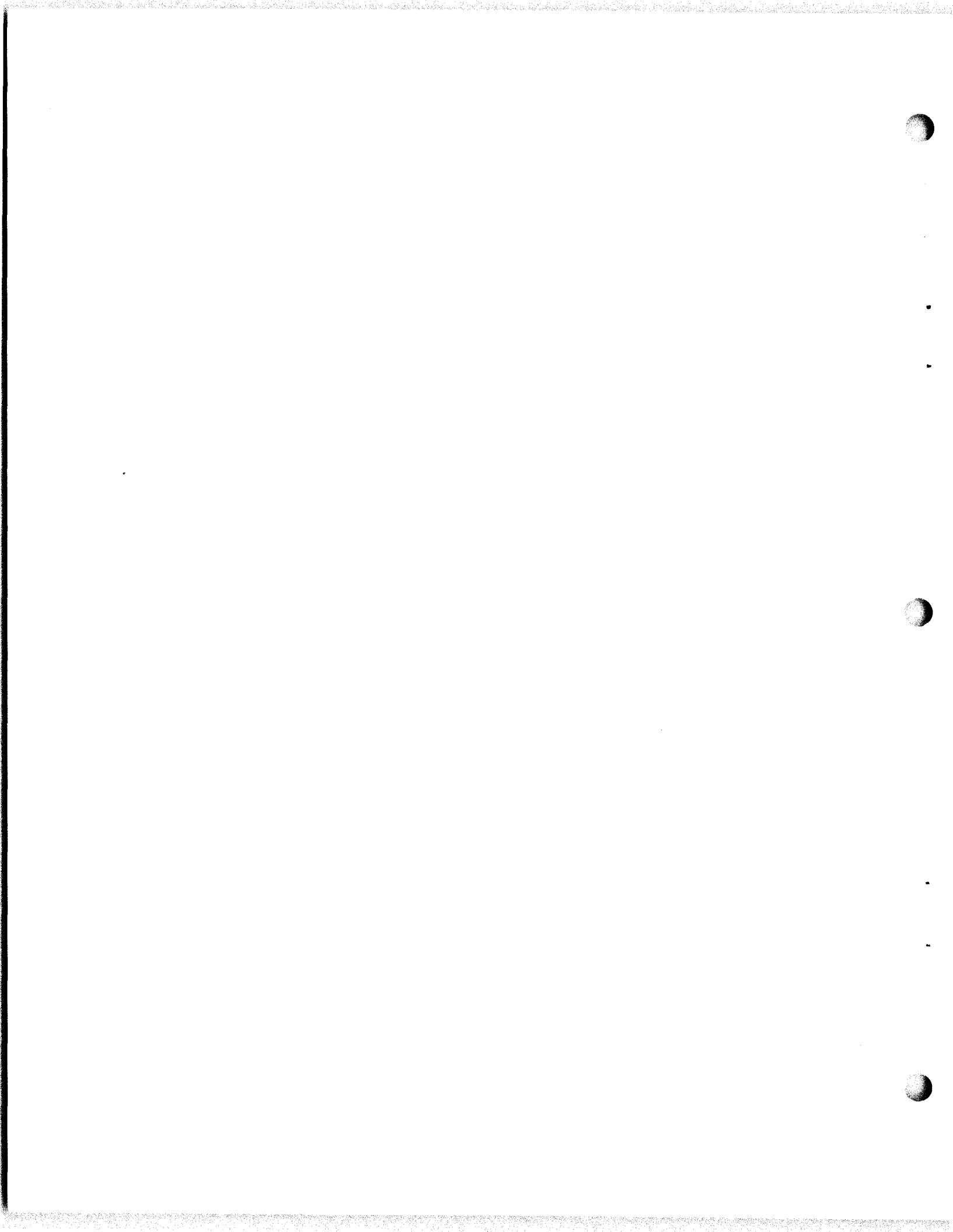

ASSIGNMENT SHEET 3.1.4.5 1A

AN/URT-23 CONTROL CIRCUITS

INTRODUCTION:

This Assignment Sheet has been developed to give you a better understanding of AN/URT-23 Control Circuit operation by providing you with a reading assignment on the subject.

LESSON TOPIC OBJECTIVES:

3.1.4.5.1 IDENTIFY the function of the APC-PPC, Keying, VSWR Bridge, Overload, and Bias control circuits of the AN/URT-23 by selecting from a list of functional descriptions.

3.1.4.5.2 IDENTIFY the input source(s) to the following control circuits: Keying, Bias, VSWR Bridge, Overload, APC-PPC by selecting from a list of sources. Given the equipment material technical manual and a control circuit diagram.

3.1.4.5.3 IDENTIFY the conducting state of each transistor in the Keying and Bias control circuits and the operating point of each vacuum tube in the AM-6909 when the AM-6909 is in an unkeyed and keyed condition by selecting from a list of conducting states. Given the equipment technical manual, a control circuits schematic diagram and characteristic I_b , E_c curves.

3.1.4.5.4 IDENTIFY the status of conduction of each transistor in the overload circuit of the AM-6909, in the absence of an overload by selecting from a list of conducting states. Given the equipment technical manual and a control circuit diagram.

3.1.4.5.5 IDENTIFY the sequence of circuit parameter changes in the overload circuit of the AM-6909, in the presence of an overload by selecting from a group of statements describing circuit parameter changes. Given the equipment technical manual and a control circuit schematic diagram.

3.1.4.5.6 IDENTIFY the input source(s) and form to the APC-PPC circuits in the AM-6909 by selecting from a list of sources and forms. Given the equipment technical manual and a control circuit schematic diagram.

3.1.4.5.7 IDENTIFY the effect each output of the APC-PPC circuits in the AM-6909 has on the circuit it controls by selecting from a group of statements describing possible effects. Given the equipment technical manual and a control circuit schematic diagram.

3.1.4.5.8 IDENTIFY the sequence of circuit parameter changes in the APC-PPC circuit of the AM-6909 for an input change by selecting from a group of statements describing sequence of circuit parameter changes. Given the equipment technical manual and a control circuit schematic diagram.

STUDY QUESTIONS: Refer to Homework Handout

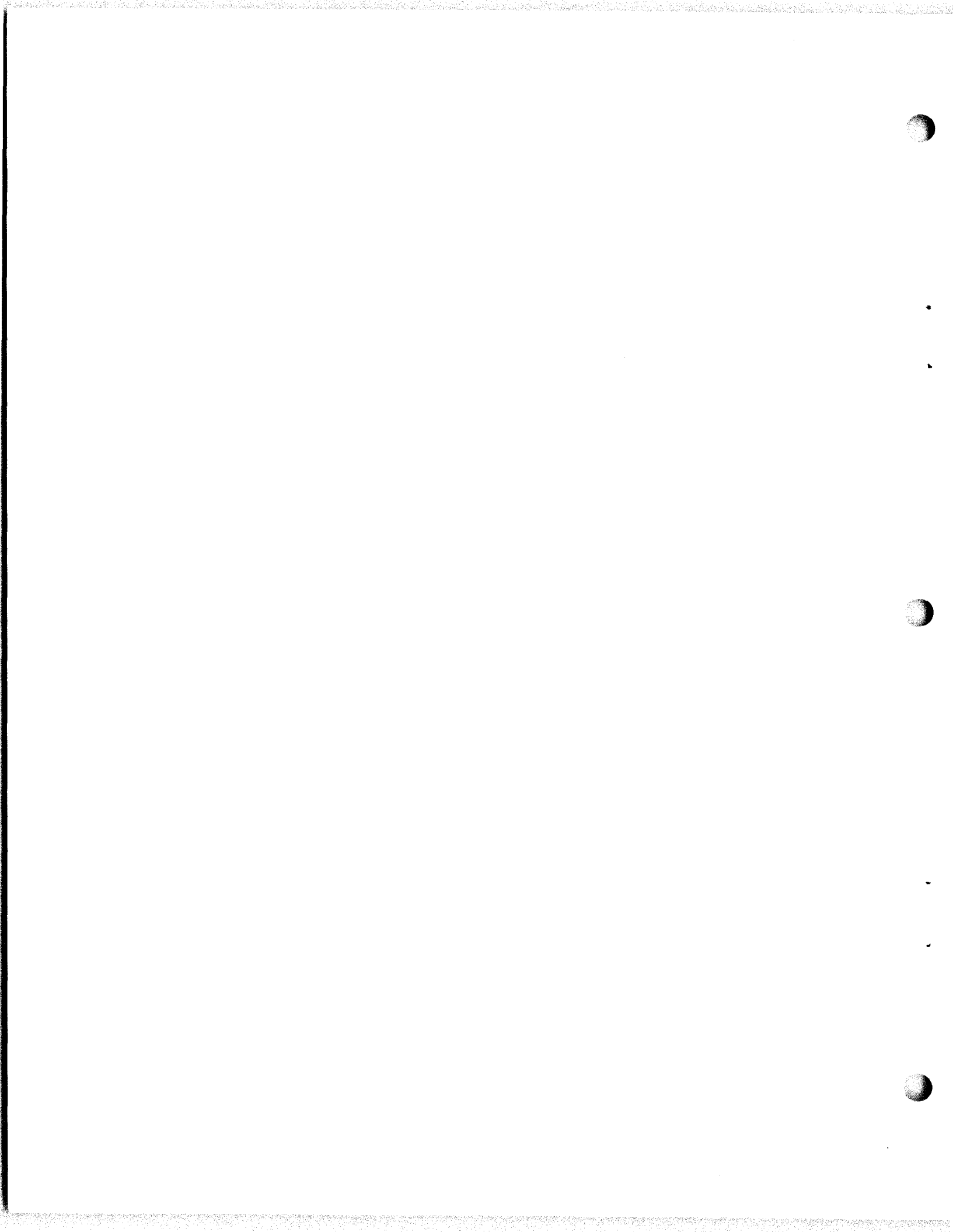

MULTIPURPOSE METER GRAPH

PA/DR SCREEN	DR PLATE	PA PLATE	PA 1	PA 2	DR 1	DR 2	INPUT POWER

POWER METER

	LOCAL	NORMAL	TUNE
LSB			
USB			
AM			
CW	X		X
FSK	X		X

MULTIPURPOSE METER GRAPH

PA/DR SCREEN	DR PLATE	PA PLATE	PA 1	PA 2	DR 1	DR 2	INPUT POWER

POWER METER

	LOCAL	NORMAL	TUNE
LSB			
USB			
AM			
CW	X		X
FSK	X		X

MULTIPURPOSE METER GRAPH

PA/DR SCREEN	DR PLATE	PA PLATE	PA 1	PA 2	DR 1	DR 2	INPUT POWER

POWER METER

	LOCAL	NORMAL	TUNE
LSB			
USB			
AM			
CW	X		X
FSK	X		X

MULTIPURPOSE METER GRAPH

PA/DR SCREEN	DR PLATE	PA PLATE	PA 1	PA 2	DR 1	DR 2	INPUT POWER

POWER METER

	LOCAL	NORMAL	TUNE
LSB			
USB			
AM			
CW	X		X
FSK	X		X

JOB SHEET

URT-23/URA-38 OPERATION, ALIGNMENTS, AND ADJUSTMENTS

JOB SHEET NO. 3.1.4.5 1J

INTRODUCTION:

From the technician's standpoint, there is more to "operating" the AN/URT-23(V) than simply being familiar with the control and indicators, and manipulating them to set up the equipment. Front panel controls and indicators can serve as built-in test equipment for the technician who knows how to use them and interpret their indications. This is often a great time saver while troubleshooting the equipment.

Before you can troubleshoot the equipment, you must be capable of operating the equipment in the usual sense. This Job Sheet is designed to help you do so.

LESSON TOPIC LEARNING OBJECTIVE(S):

3.1.4.5.9 VERIFY the operational status of the APC-PPC, Keying, Bias, VSWR Bridge, and Overload control circuits in the AM-6909 by measuring voltages at specified test points and comparing to technical manual specifications. Given the equipment technical manual and a Job Sheet.

REFERENCES:

NAVELEX 0967-LP-879-5020, Radio Transmitting Set AN/URT-23(V) Technical Manual

EQUIPMENT AND MATERIALS:

1. AN/URT-23(V) Installation
2. AN/PSM-4 Multimeter
3. AN/USM-117 Oscilloscope or equivalent
4. DA-242 Dummy Load
5. 6" Regular Screwdriver
6. 6" Phillips Screwdriver

PRECAUTIONS TO BE OBSERVED: Observe all standard safety precautions

3.1.4.5 1J

JOB STEPS: A. URT-23 Front Panel Checkout

- Step 1. Perform all preoperational checks.
- Step 2. Place bulkhead switch in "ON" position.
- Step 3. Place primary power switch (1A1S4) in "ON" position.
- Step 4. Turn on AN/URA-38 and make sure the elements are not on either end stop.
- Step 5. Place Mode Selector Switch T-827 in "Standby" position.
 - a. The dial indicator lamp on front panel T-827 should light.
 - b. The power indicator lamp on front panel PP-3916 should light.
 - c. The blower motor in the AM-6909 should energize.
 - d. The standby indicator lamp on front panel on AM-6909 should light.
 - e. Turn band selector switch on front panel of AM-6909 from automatic to any band, then back to automatic. Band select motor should energize and turn to selected band, then return to band selected by T-827.
 - f. Select T-827 operating frequency of 12 MHz.
- Step 6. After three minutes place mode switch on front panel T-827 to LSB. You should hear Operate Relay 1A1K1 energize, the standby light should go out and operate light should come on.

Question: What causes the operate relay to energize after three minutes?

NOTE: Log readings for Step 7 through 20 on the graphs provided at the end of this Job Sheet. (Page 146)

- Step 7. Place the multipurpose meter switch on the front panel AM-6909 to the following positions and record the meter readings:
 - a. PA/Driver Screen: _____ VDC
 - b. Driver Plate: _____ VDC
 - c. PA Plate: _____ VDC
- Step 8. Place local/normal/tune key switch front panel AM-6909 to the local key position. Place multipurpose meter switch to the following positions and record the meter readings:
 - a. PA/Driver Screen: _____ VDC
 - b. Driver Plate: _____ VDC
 - c. PA Plate: _____ VDC

3.1.4.5 1J

Question: Why did the voltages change from an unkeyed to a keyed condition?

Step 9. With local/normal tune key switch in local key position, place multipurpose meter switch to the following positions and record meter readings:

NOTE: Adjust PA bias pot (1A1R10 on the front panel AM-6909) so that the LOWEST conducting tube current is 240 mA.

a. PA Plate 1: _____ mA

b. PA Plate 2: _____ mA

NOTE: Adjust driver bias pot (1A1R9 on left side of AM-6909) so the LOWEST conducting tube current is 320 mA.

c. Driver 1: _____ mA

d. Driver 2: _____ mA

Step 10. Look at the output power meter on front panel AM-6909, mode selector switch on T-827 still in LSB, local/normal/tune key switch still in local key position.

a. Output power meter reads _____ watts.

Question: Does the meter indicate the reading you expected?

YES/NO WHY?

Step 11. Now place the local/normal/tune key switch in the tune position. While holding switch in tune key look at output power meter. It should indicate about 100 watts (+/- 50 watts). Release the switch.

Step 12. Place mode selector switch on T-827 to USB, the local/normal/tune key switch on AM-6909 to local key, output power meter indicates _____ watts.

Step 13. Now place the local/normal/tune key switch to the tune position. Output power meter should indicate 100 watts. Release the switch.

Step 14. Place the mode selector switch on T-827 to the AM position, and put the local/normal/tune key switch in local key position. Output power meter indicates _____ watts. Go to AM normal key. Speak into the handset. Output power meter peaks at _____ watts.

Question: Why does the output power meter read differently in AM than it did in LSB and USB modes?

3.1.4.5 1J

- Step 15. With the mode selector switch on the T-827 still in AM, place the local/normal/tune key switch in tune key. The output power meter should read 100 watts. Release the switch.
- Step 16. Place the mode selector switch on the T-827 to CW, and key the T-827 (exciter) by placing the CW plug in the front panel. The output power meter should indicate 500 watts (+/- 100 watts).
- Step 17. While still keyed in CW vary the power control (1A1R13) on the front panel of the AM-6909. The output power meter reading should vary. Now adjust the power control so that it is fully clockwise and remove the CW plug from the T-827.
- Question: Why does the power control have an effect on the output power?
- Step 18. Place the mode selector switch on T-827 to FSK position. Key the transmitter using the FSK toggle switch. The USB line level meter should deflect. Output power meter should read 500 watts.
- Step 19. Place the mode selector switch on T-827 to LSB position. Put multipurpose meter switch on AM-6909 to input power position, and pick up handset. Press push to talk button. While talking into handset, input power meter should deflect as well as the output power meter. The indication on output power meter should peak at about 500 watts. Release PTT button.
- Step 20. Place the mode selector switch on T-827 to USB and repeat same procedure used in step 19.

MULTIPURPOSE METER

PA/DR Screen	DR Plate	PA Plate	PA 1	PA 2	DR 1	DR 2	Input Power

OUTPUT POWER METER

	LOCAL	NORMAL	TUNE
LSB			
USB			
AM			
CW	X		X
FSB	X		X

3.1.4.5 1J

JOB STEPS: B. AN/URT-23(V) Control Circuit Test Point Checks

Step 1. Bias circuit checks and adjustment.

- a. Set the T-827B mode selector switch to LSB.
- b. Check the driver bias by measuring the DC voltage at terminal 8 of 1A1A1TB1 with the transmitter unkeyed and keyed. Record the readings below:

(1) Cutoff bias _____ VDC (xmtr unkeyed)
(-95 VDC +/- 15 VDC)

(2) Class A bias _____ VDC (xmtr keyed)
(0 to -24 VDC)

- c. Check the three conditions of PA bias by measuring voltage at the emitter of 1A1A6Q21. This requires the use of a circuit board extender. Key the transmitter as required, and record the readings below.

- (1) Cutoff bias (transmitter unkeyed)

Q21 emitter voltage _____ VDC
(-110 VDC +/- 15 VDC)

PA PLATE CURRENT (MPM) _____ mA
(0 mA)

- (2) Class AB1 bias _____ VDC

PA PLATE CURRENT (MPM) _____ mA
(240-280 mA)

- (3) Class B bias (transmitter keyed, T-827 in FSK)

Q21 emitter voltage _____ VDC

PA PLATE CURRENT (MPM) _____ mA
(400-600 mA)

Step 2. Overload Circuit Checks.

- a. Ensure that the OVERLOAD SWITCH is in the ALARM position. Using an AN/PSM-4 lead as a jumper, connect 1A1A5TP1 to 1A1A5TP5. The OVERLOAD light should come on and the ALARM should sound.
- b. Press the OVERLOAD SWITCH to the RESET position, and release to the DISABLE ALARM position. The overload alarm should silence, but the light should remain on.
- c. Set switch to the ALARM position. The light should remain lit and the alarm should sound.
- d. Remove the jumper, reset the alarm, and switch to the ALARM position.

3.1.4.5 1J

Step 3. Keying Circuit Checks

- a. Check the keying circuit by measuring the DC voltage at 1A1A5TP2. Board the readings obtained.

Unkeyed: $\frac{\quad}{(0 \text{ to } -.3 \text{ VDC})}$ VDC Keyed: $\frac{\quad}{(5 \text{ VDC} + .2 \text{ V})}$ VDC

- b. Key the transmitter and reinstall the jumper between TP1 and TP5. The overload alarm should sound, and the voltage at TP2 should drop to zero volts if the key interlocks circuit is operating properly. Remove the jumper and reset the alarm.
- c. Rotate Band Select Switch. The voltage at TP2 should drop to zero if the key interlock circuit is operating properly. Place band select switch back to auto.
- d. Unkey the transmitter. Remove the multimeter. Set T-827B to STDBY.

Step 4. APC-PPC Check.

- a. Set the transmitter up on 12 MHz. Key the transmitter in each of the modes listed below. Record the DC voltage at each of the test points. Use an oscilloscope to check the waveform at 1A1A6TP1. All test points are on the 1A1A6 board.

Modes	INPUT TP-1	PCC TP-2	APC TP-3	TUNE TP-4
LSB/TK	_____	_____	_____	_____
CW Norm	_____	_____	_____	_____
AM Local (No Modulation)	_____	_____	_____	_____
AM Norm (Modulation)	_____	_____	_____	_____

NOTE: Have the instructor check your readings.

JOB STEPS: C. URA-38 Front Panel Checkout.

Step 1. Place URA-38 Mode Selector Switch in "AUTO"

Step 2. Turn on AN/URA-38 2A1S7;

- a. 2A1DS2 should light.
- b. TUNING light should light briefly, then extinguish, indicating the tuning elements have gone to their home position. If elements are already in their home position the TUNING lamp will remain off.

3.1.4.5 1J

Step 3. Set mode selector to MANUAL.

Step 4. Set L-C switch at C.

Step 5. Depress RIGHT pushbutton until TUNING lamp extinguishes.

a. Record readings of ELEMENT POSITION meter. _____

NOTE: Capacitor is now on far end stop.

b. Check voltage at 1A1A5P1-B _____, 1A1A5Q4C _____,
key and check 1A1A5TP2 _____.

Step 6. Set L-C switch at L.

Step 7. Depress RIGHT pushbutton until TUNING lamp extinguishes.

a. Record reading of ELEMENT POSITION meter. _____

NOTE: Inductor is now on far end stop.

b. Check voltage at 1A1A5P1-B _____, 1A1A5Q4C _____,
key and check 1A1A5TP2 _____.

Step 8. Set mode selector switch to SILENT or AUTO.

Step 9. Depress RETUNE button. TUNING indicator lamp should light while elements are returning to their home position, then extinguish.

a. Record reading of ELEMENT POSITION meter. _____

NOTE: Inductor is now on home end stop.

b. Check voltage at 1A1A6P1-S _____, 1A1A6Q17C _____,
and at 1A1A6TP4 _____.

Step 10. Set L-C switch at C.

Step 11. Record reading of ELEMENT POSITION meter. _____

NOTE: Capacitor is now on home end stop.

Step 12. Set mode selector to MANUAL.

Step 13. During normal operation the elements should be positioned between the home end and far end stops. Since no R.F. power is applied in this lab, their position is not critical. Position them at this time. Check and record the following voltages.

1A1A6P1-S _____ 1A1A6TP4 _____

1A1A6Q17C _____

Key and check 1A1A5TP2 _____, 1A15PI-B _____,

1A1A5Q4C _____

3.1.4.5 1J

Step 14. Key the AN/URT-23(V) while observing the front panel of the C-3698.

a. Tell what you observed. _____

b. What does this signify? _____

Step 15. Secure lab equipment.

ASSIGNMENT SHEET 3.1.4.6 1A

AN/URA-38 FUNCTIONAL BLOCK DIAGRAM ANALYSIS

INTRODUCTION:

In this lesson you will learn the theory of operation of the AN/URA-38 Antenna Coupler to a block diagram level. You will learn the Functions, Inputs, and Outputs of each Block.

LESSON TOPIC OBJECTIVES:

3.1.4.6.1 IDENTIFY the input and output signal(s) to the following areas: Home Logic, Keying Logic, Tune Logic, Ready Light Logic, Servo Amplifiers, Motor Control, Motor On, and Brake Circuits. Given the equipment technical manual, and a functional block diagram.

3.1.4.6.2 IDENTIFY the operational sequences for the following modes: Automatic, Manual, and Silent. Given a list of statements concerning various operational characteristics.

STUDY ASSIGNMENT: None

STUDY QUESTIONS: 3.1.4.6 1H (See following page)

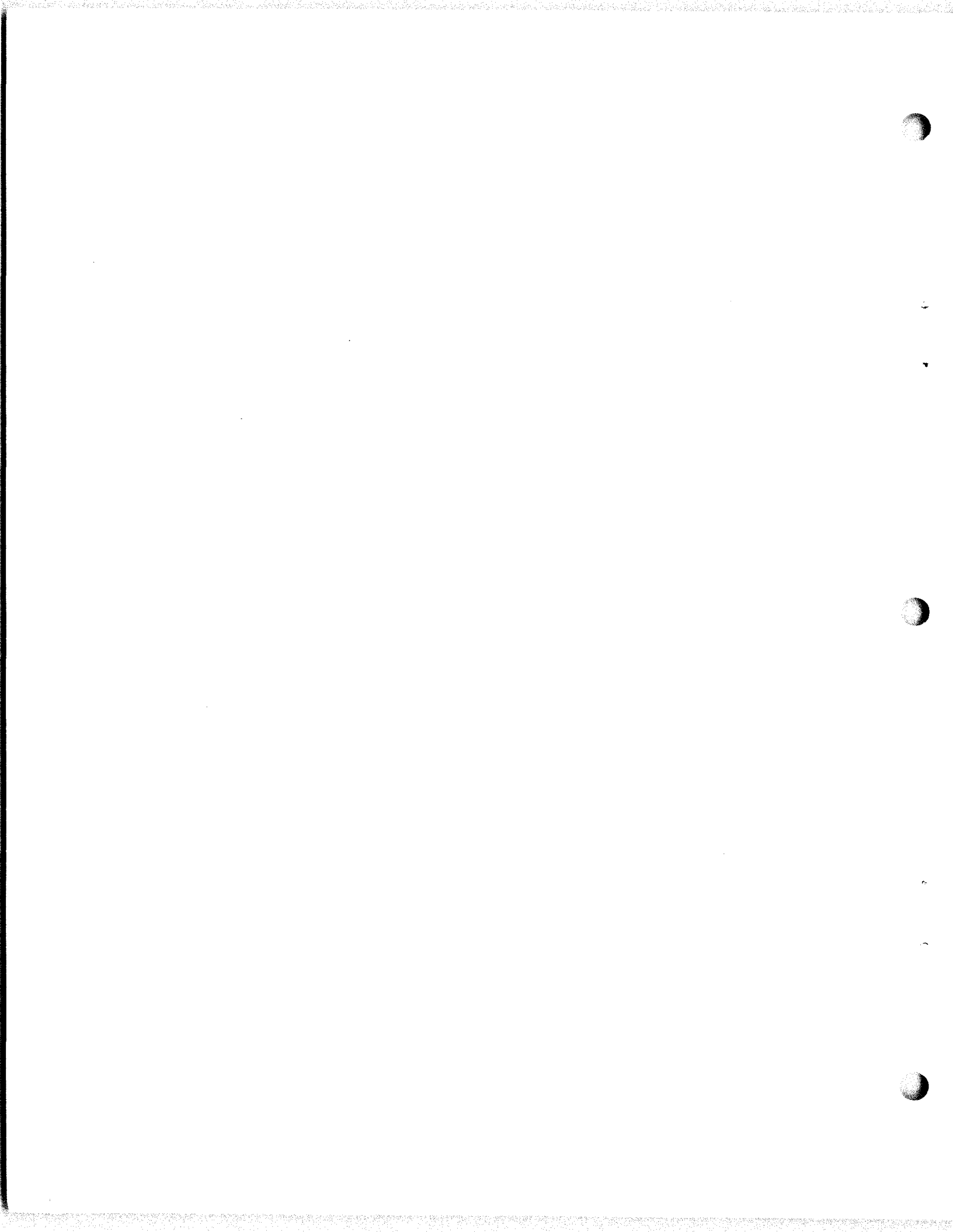

JOB SHEET

AN/URT-23(V) TROUBLESHOOTING

JOB SHEET NO. 3.1.4.5 2J

INTRODUCTION:

This Job Sheet has been prepared to assist you in accomplishing Learning Objective 3.1.4.5.10 by providing you with hands on experience in troubleshooting the URT-23(V) to a faulty component part.

LESSON TOPIC LEARNING OBJECTIVE:

3.1.4.5.10 ISOLATE a malfunction to the faulty part in the control circuits of the AM-6909. Given the equipment technical manual, test equipment, tools, and a Job Sheet.

REFERENCES:

NAVELEX 0967-LP-87905010, Radio Transmitting Set AN/URT-23(V) Technical Manual

EQUIPMENT AND MATERIALS:

1. AN/URT-23(V) Installation
2. AN/PSM-4 Multimeter
3. AN/USM-117 Oscilloscope or equivalent
4. DA-242 Dummy Load
5. 6" Regular Screwdriver
6. 6" Phillips Screwdriver

PRECAUTIONS TO BE OBSERVED: Observe all normal safety precautions

JOB STEPS:

- Step 1. Using the six step troubleshooting procedure, isolate a malfunction in the AN/URT-23(V) to a faulty component part.

