

SECTION 22

CATHODE-RAY-TUBE CIRCUITS

ELECTROSTATIC.

The circuits used for the electrostatic type of cathode-ray tube are functionally similar to those used for the electromagnetic type of tube, but they differ in the manner of accomplishing their function. Only the electrostatic type will be discussed in this paragraph. Basically, the cathode-ray tube provides a fast moving, easily and quickly deflected electron beam for use in waveform viewing and analysis, and for special display purposes. Generally speaking, the display types of CRT are mostly magnetically controlled, while the types universally used in test oscilloscopes and synchoscopes, for waveform checking, are electrostatically controlled. Therefore, the discussion in this paragraph will be restricted to oscilloscopes. Later paragraphs in this section will describe deflection-modulated display circuits such as used in type A and J scans, and intensity-modulated circuits such as the B and C types, which can employ an electrostatic CRT. All cathode-ray tubes have basic control circuits which are necessary if the tube is to be used at all. These circuits control intensity (brilliance), focus, and beam positioning (centering, both horizontal and vertical). Other circuits with which the CRT is concerned are horizontal and vertical amplifiers, sweep circuits, and synchronizing circuits. All of the latter circuits are standard circuits, with special attention paid to the design for bandwidth, response, and linearity. In some special cases there are peculiar circuits which are mainly combinations of standard circuits used for packaging the components into a convenient size, and for economy. For example, while a console unit may have high and low voltage supplies, they are usually separate and use separate transformers, whereas the conventional oscilloscope uses one transformer to supply both high and low voltage, bias, and filament power.

BASIC OSCILLOSCOPE CIRCUITS.

APPLICATION.

The basic circuits described below are used to adapt an electrostatic CRT for use as an oscilloscope which can be utilized for waveform analysis.

CHARACTERISTICS .

Vertical input (Y axis)

High input impedance (approximately 2 megohms shunted by 40 picofarads)

Step attenuator

Good frequency response (10 cps to 1 megacycle)

Horizontal input (X axis)

High input impedance (approximately 2 megohms shunted by 40 picofarads)

Step attenuator

Internal sweep or external signal

Sweep

Selectable sync (polarity and input)

Sweep frequency 2 cps to 100 kc

Retrace blanking

Intensity input (Z axis)

CIRCUIT ANALYSIS.

General. The following circuits were chosen as basic examples of the circuits generally used in oscilloscopes. Each was selected to bring out the basic principles and requirements necessary for circuits used in waveform analysis, even though a similar circuit may be found elsewhere in this manual. The discussion is limited to the essentials needed for use with cathode-ray tubes.

Beam-Positioning Circuits. A simple oscilloscope using basic beam-positioning circuits is shown in the accompanying illustration. For a complete schematic of an elementary oscilloscope, see Basic Electronics, NAVPERS 10087A, Chapter 17. Note that the voltages are taken from a common voltage divider between B+ and B-. The divider is grounded at a convenient point, usually at the positive voltage required for the accelerating anode (No. 2), and both ends are above ground. Thus, with the positive low voltage and

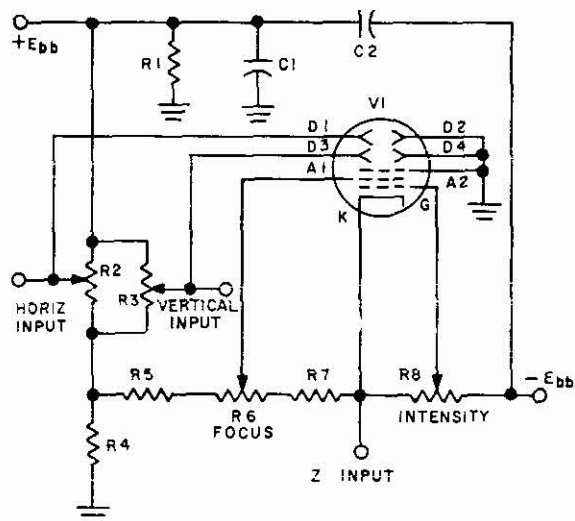

Simplified Oscilloscope, Showing Controls

negative high voltage at above-ground potential, the case and chassis can be grounded for protection of the operator. It also permits the anode and one of each pair of deflection plates to be grounded, to form a simple unbalanced deflection or positioning circuit. This connection also keeps the deflection plates and accelerating anode at the same potential, and avoids defocusing effects from differences in potential between them.

It is evident from the schematic that resistors R4, R5, R6, R7, and R8 form a voltage divider from B minus to ground, and at the junction of R4 and R5 some positive voltage exists. Since the cathode of the CRT is connected at a less negative point on the divider than the grid, the grid is negative with respect to the cathode, and is adjustable by means of potentiometer R8. As in the conventional circuits, variation of this grid bias permits the tube to conduct more or less heavily, as desired. Anode No. 1 is connected to a much lower point on the divider; thus it is

effectively much more positive than the cathode and grid, and attracts the electrons from the cathode. By varying the d-c potential on this focusing anode, the electron beam from the cathode is directed so that it converges at a point on the face of the CRT. Anode No. 2 of the CRT is grounded; thus, since it is at a more positive voltage than the focusing anode, it attracts the electron beam and accelerates it. The accelerating anode is a concentric ring similar to the focusing anode and the focused beam passes through the center, losing only stray unfocused electrons. The No. 2 anode current, therefore, is minute, and does not detract from the beam. As the beam passes from the accelerating anode to the face of the tube, it passes between two sets of deflecting plates. The plates of the set nearest the No. 2 anode are positioned horizontally above and below the tube centerline, and deflect the beam vertically. (The vertical deflection plates are physically located nearest the No. 2 anode, for maximum control of the electron beam.) The plates of the second set are nearest the face of the tube; they are positioned vertically to the left and right of the centerline of the tube, and deflect the beam horizontally.

Positioning controls R2 and R3 are parallel-connected, and are connected between B+ and ground through R1 and R4. Since one of each pair of deflecting plates is connected to ground, a d-c positioning voltage exists between the plates and ground. Thus, by adjusting the positive voltage on R2 and R3, the electron beam is attracted (deflected) toward them and can be centered on the tube face. A simplified version of the positioning circuits is shown in the following figure; since one of each set of deflecting plates

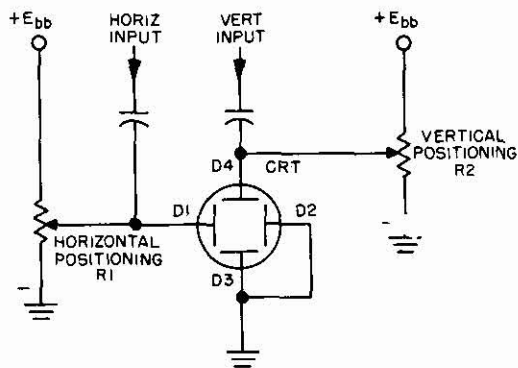

Unbalanced Positioning Circuit

is connected to ground, the circuit is unbalanced. Controls R1 and R2 are represented simply as variable potentiometers between B+ and ground. A simplified positioning circuit of the balanced type is shown in the accompanying illustration, and is discussed below.

In the balanced circuit, each deflecting plate (D1 through D4) is controlled by a separate potentiometer (R2, R3, R6, and R7), and the plates are isolated and balanced equally by being connected to the positioning controls through equal resistors R1, R4, R5, and R8. Each plate is also connected to the deflection amplifiers, through a cou-

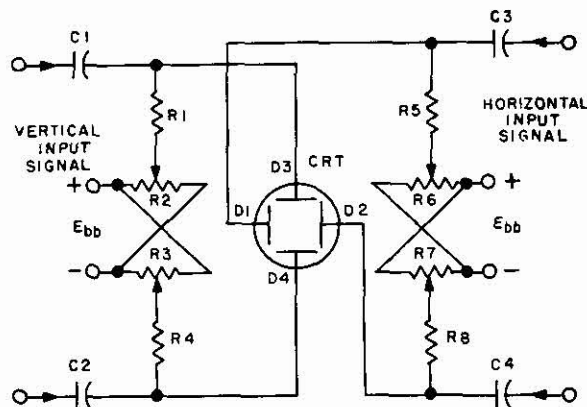
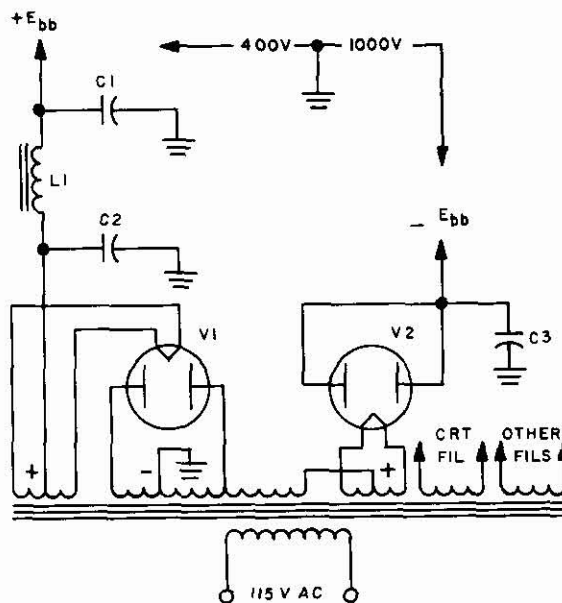

Illustration 22-3
Balanced Positioning Circuit

pling capacitor, in a push-pull arrangement. Thus the CRT is balanced for dc, for ac, and for any stray capacitance to ground. Since the isolating resistors (R1, R4, R5, and R8) are always of a very large value, the deflecting plates may be connected into any circuit without danger to the operator (it takes a current of only a few microamperes to drop the positioning voltage to zero).

Power Supply. A typical power supply for an elementary oscilloscope is shown in the illustration. Two full-wave rectifier tubes are used with a single transformer to supply a positive low voltage for circuits other than the CRT



Typical Power Supply

and a negative high voltage for the CRT. The low-voltage supply is a conventional full-wave rectifier circuit with the center tap grounded, and B_+ is taken from the cathode and applied to a single pi-type C-L filter (C1, L1, and C2). The negative high-voltage supply uses the other full-wave rectifier tube (V2), with the plates parallel-connected as a half-wave rectifier, and the low-voltage center tap used as a common ground. Because of the small amount of current taken by the CRT, the simple R-C filter offered by the bleeder and C3 is sufficient for hum elimination. The low-voltage output is on the order of 400 volts, and the high-voltage output is about 1000 volts. The filament windings for the CRT, as well as the other tubes, are also included on the same transformer, providing a compact and economical power supply.

Sweep Circuit. To provide a time base for the waveform, the CRT beam must be deflected horizontally across the face of the tube from left to right, then caused to return quickly from right to left, ready to resume another cycle of operation. A sweep voltage obtained by the charge and discharge of a capacitor is employed for this purpose. During the charging period the sweep is developed and the beam moves from left to right; during the discharging period the capacitor reverses polarity of deflection and the beam moves back to the start (retrace time). Some oscilloscopes provide blanking for the retrace period so that the return sweep cannot be seen. A typical thyratron type sweep generator for general oscilloscope use is illustrated. Other types of relaxation oscillators, such as a neon tube, a vacuum tube R-C oscillator with discharge tube, or a multivibrator, could be used, provided that a reasonably linear sawtooth sweep waveform is produced.

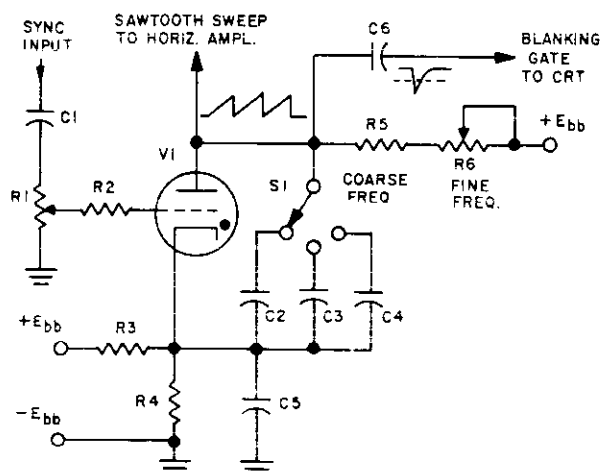

Typical Sawtooth Generator (Thyratron)

Thyratron tube V1 operates as a relaxation-type oscillator at frequencies from 5 to 100,000 cps. The frequency of

operation is selected roughly by S1, which connects various values of capacitance between the cathode and plate of the tube. The frequency of operation is adjusted finely by variable resistor R6, which, together with R5 and the capacitor selected by S1, provide a specific frequency fixed by the time constant of the R-C circuit. R5 primarily determines the amplitude over the range adjustable by R6 for a specific supply voltage. Normally, the circuit starts in an inoperative condition with the cathode fixed-biased by voltage divider R3 and R4, and capacitors C2, C3, or C4 (as selected by S1) charge slowly at a rate determined by the setting of R6. When the voltage between the cathode and plate reaches the ionization voltage (value depends upon type of gas used), the tube fires. Heavy current flows from the cathode to the plate and effectively produces a short-circuited condition across the capacitor selected by S1. Thus, the capacitor quickly discharges until the deionization voltage is reached and the tube stops conducting, resting in a biased-off condition, and the cycle of operation resumes again. During the charging period, blanking capacitor C6 is also charging slowly and reduces the CRT bias, allowing operation. When V1 conducts, C6 discharges through a grid-cathode resistor in the CRT circuit, and the common bleeder, biasing the CRT off and blanking off the retrace interval.

Capacitor C1 is a coupling capacitor which applies the sync signal between R1 and ground; the amount of synchronizing signal fed to the grid of V1 is adjusted by the position of R1. Resistor R2 is a protective resistor which limits grid current flow to a safe value; it also acts as a decoupling resistor. Capacitor C5 bypasses cathode resistor R4 to prevent degenerative feedback during sweep operation, and effectively shunts R4 so that it is not a part of the R-C time constant circuit.

Synchronizing Methods. To keep the waveform stationary on the face of the CRT tube, the sweep frequency must be an exact multiple or submultiple of the waveform under observation. To avoid the need for constant resetting of the sweep frequency control because of drift, power-supply voltage changes, etc, a sweep-locking or synchronizing circuit is provided. In the basic unit, a three-position switch is generally provided to permit selection of either an external signal, a 50-cycle signal, or the internal sweep (or input signal) taken from the vertical deflection amplifier plate. Since some circuits do not have an output of the proper polarity for synchronization, an adjustable synchronizing circuit is sometimes included to permit selection of sync signal and choice of sync polarity. The accompanying illustration shows a typical sync-input circuit of this type. Switch S1 selects one of three inputs: an external synchronizing signal, a 50-cycle signal (usually taken from a filament winding), or the output from the vertical amplifier (this is the signal under observation, but it is called **internal sync**); it then applies the input through coupling capacitor C1 to the grid of V1. Tube V1 is a parhase amplifier, with the grid returned to ground through R1. The tube is cathode-biased and unbypassed; the plate and cathode resistor, R2 and R3, are of the same value, so that for the same current identical signals are developed in the plate and cathode circuits (except that the polarity of one is opposite the polarity of the other). For a positive input signal, a negative plate-output signal is developed, and the

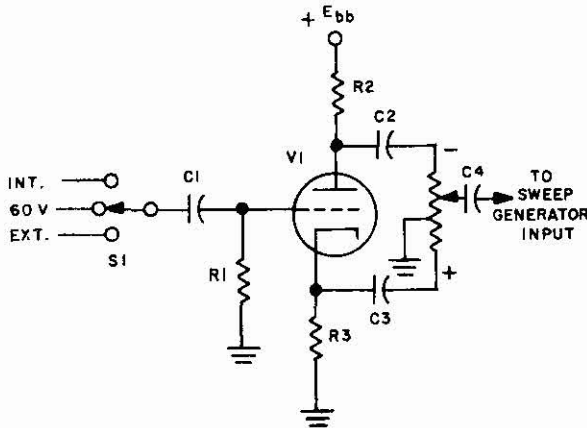

Typical Sync Input Circuit

cathode-output signal is positive. For a negative input signal, a positive plate-output signal is developed, and the cathode is negative. Both plate and cathode outputs are coupled through capacitors C2 and C3 to a common load resistor, grounded at its center tap and also variable. At the ground position both signals are equal and opposite, and of zero amplitude; therefore, no output is obtained. As R4 is rotated in either direction, the signal amplitude is increased. Since the synchronizing signal to the sweep generator must be of positive polarity, for a negative input to V1 a positive signal is available on the plate side, and for a positive input to V1 a positive signal is available on the cathode side. Thus a signal similar to the input signal but of positive polarity is obtained and coupled through C4 to the thyatron sweep generator discussed above. When this paraphase input is supplied, the sweep generator has a fixed grid resistor instead of the variable one shown in the illustration of the thyatron sweep generator.

When the sweep generator is adjusted to a slightly lower frequency than that desired, a positive-going sync signal applied to the grid of the thyatron will cause ionization to occur earlier in the operating cycle. Since this has the effect of changing the ionization potential, the frequency of operation is increased and the sweep generator locks-in and operates at the same frequency as the sync signal. Thus the CRT waveform remains stationary, rather than drifting across the screen, because it is synchronized so that the sweep occurs at the same place at the same time each sweep.

Deflection Amplifiers. To produce satisfactory deflection with small signals, it is necessary to employ both vertical and horizontal deflection amplifiers. These stages may be single-ended or push-pull (unbalanced or balanced); they are conventional video amplifiers designed for the desired frequency response and linearity. A simple equipment usually provides only one stage of amplification and an output stage, whereas a laboratory-type equipment provides two or three stages of amplification with output stages.

The horizontal amplifier in a good scope is identical to the vertical amplifier, permitting the same signal to be applied to the X axis and the Y axis. In the majority of oscilloscopes, however, only the horizontal sweep is amplified; thus less gain is needed since the sweep output voltage is large. Because the sweep is usually a submultiple in frequency of the observed signal, less frequency response is needed. Thus the horizontal deflection amplifier need not be described, since the vertical amplifier has more stringent requirements.

Since the vertical amplifier must be able to amplify very weak signals with sharp rising waveforms, it must have good frequency response and large amplification. To cover the range of signal amplitudes encountered, the vertical input is usually provided with an attenuator. Simple potentiometer-type attenuators are shown in the accompanying figure.

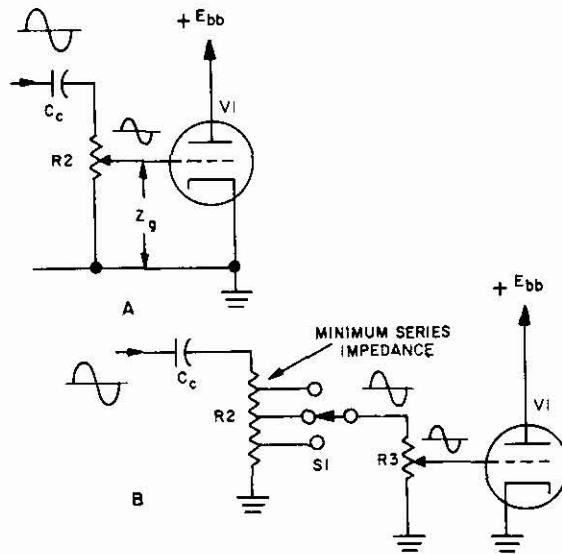

Potentiometer Attenuators

The simple circuit shown in part A of the illustration uses the potentiometer as the output load resistor of an R-C coupling network. Thus, since the grid-to-ground impedance (Z_g) of the input tube is in shunt across it, as the potentiometer arm is moved upward the impedance presented to the circuit under test is decreased (less loading and less attenuation). The simple step-attenuator circuit shown in part B of the illustration is a better type of input circuit, allowing coarse selection of the attenuation ratio with switch S1, and fine adjustment with potentiometer R3. It is evident that even for the smallest input step resistance, the full range of R3 is available for control. With the available settings of S1, the input impedance will never decrease to a value less than the series section of R2 (that portion above the upper tap) plus the parallel combination of the remainder of R2, R3, and the grid-to-ground impedance of

the input tube. The most desirable input is in the range of megohms, with little or no shunting capacitance to ground. To achieve this result sometimes a cathode follower input stage is combined with a step attenuator to isolate the oscilloscope input from the stage being tested. The usual input capacitance is on the order of 30 picofarads, which can be appreciable (1000 ohms at 5 mc). Therefore, frequency-compensated attenuators are used in the better type of oscilloscopes to minimize the effect of input capacitance (as shown in the figure), by presenting identical impedance-response curves to the circuit under test for the various attenuator settings.

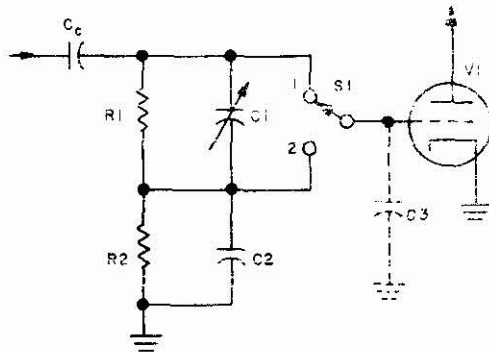

Frequency-Compensated Step Attenuator

Frequency-compensated attenuators further provide the same voltage division ratio (resistive to reactive) of the input signal, so that the drop-off in signal level at the higher frequencies can be compensated for in the following video amplifiers. Attenuator compensation is usually effective over the entire useful frequency range of the oscilloscope. The attenuator potentiometer is frequency-sensitive because of the distributed and stray capacitance from the moving arm of the potentiometer, the wiring and circuit elements, and the electron tube input capacitance to ground. While the resistance of the potentiometer must be as high as possible to maintain maximum input impedance, the greater the resistance, the greater the effect of the stray capacitance. Since there is only one setting of the attenuator arm where the resistance division and the capacitance division are of the same ratio, shunt capacitors C1 and C2 are added to the attenuator, as shown in the illustration, to provide frequency compensation. When the attenuator (S1) is set to position 1, the input to the amplifier is reduced to one-tenth of the total signal across the voltage divider. R2 is then one-tenth of R1 plus R2. The ratio of the capacitive reactance is then chosen to be of the same order. That is, the reactance of C2 and the stray capacitive reactance of C3 is made to be one-tenth of the total reactance of C1 in series with the parallel combination of C2 and C3. Normally, because of the difficulty in measuring the stray capacitance indicated by C3, C1 is made variable and is adjusted during operation to produce the best compensation effects, using a square-wave input (this is made initially and once calibrated requires only an occasional check).

Since most attenuators and amplifiers have reduced high-frequency response because of the shunting effect of stray capacitance, a parallel R-C circuit in series with the input lead is usually inserted to boost the relative response of the attenuator at high frequencies. Another device is an input probe located at the end of a special connecting cable which applies the input to the vertical amplifier. The probe houses a frequency-compensated voltage divider, and is constructed to reduce to a minimum the amount of shunt capacitance existing at its input terminals. This is usually called a "D-C probe", or simply "input probe", as distinguished from an "r-f probe", which contains a diode rectifier to remove the modulation.

A typical three-stage vertical amplifier is shown schematically in the accompanying illustration; it drives a conventional push-pull parafase deflection output amplifier (see Section 6 for a discussion of deflection output amplifier stages). The vertical input signal is applied through blocking and coupling capacitor C1 to a cathode follower attenuator stage incorporating triode V1. The attenuator is a two-step, frequency-compensated type. For signals under 25 volts, S1 connects the input directly to the grid of V1. For signals over 25 volts, C2 is adjusted so that the time constant of the circuit consisting of C2 and R1 is the same as the time constant of the circuit consisting of C3 and the parallel combination of R2 and R3, including the stray grid-to-ground capacitance of V1. Thus the attenuation in this position of S1 is practically constant for all frequencies. The constants are so proportioned that the input impedance is approximately 2 megohms for either position of the attenuator, with an effective shunt input capacitance of about 40 picofarads. Although V1 has its cathode connected to the -280-volt supply, the plate current flow through R4 and R5 is sufficient to bias the cathode positive with respect to ground. The output of cathode follower V1 is taken from the cathode through C5, which is a large capacitor (on the order of 8 microfarads), and applied to the input gain potentiometer, R6. Capacitor C4 is a conventional filter capacitor to bypass the negative supply. Y-gain (vertical) control R6 controls the amplitude of the input signal to the two-stage, high-gain compensated video amplifier consisting of V2 and V3. Both high-frequency and low-frequency compensation are employed in each stage. The cathode of V2 is bypassed by a small capacitor, which makes it degenerative for low frequencies, thus reducing the response and flattening out the low-frequency response. Low-pass RC filters R8, C7 and R9, C10 offer a high impedance to the low frequencies and a shunt path to the high frequencies in the plate circuits of the amplifiers. Thus the effective load impedance at low frequencies is increased, which compensates for the normal drop off at about 30 cycles, and extends the response down to 2 cycles. The high-frequency response is increased by peaking coils L1 and L2, which compensate for the shunting effect of tube and wiring capacitance, providing a reactance which increases with frequency. The use of the peaking coils extends the response up to about 1 megacycle. To help improve the high-frequency response, plate load resistors R7 and R10 are made low in value to reduce the shunting effect of stray capacitance. To improve the low-frequency response, the time constants of R-C coupling networks C8, R11 and C9, R15 are long

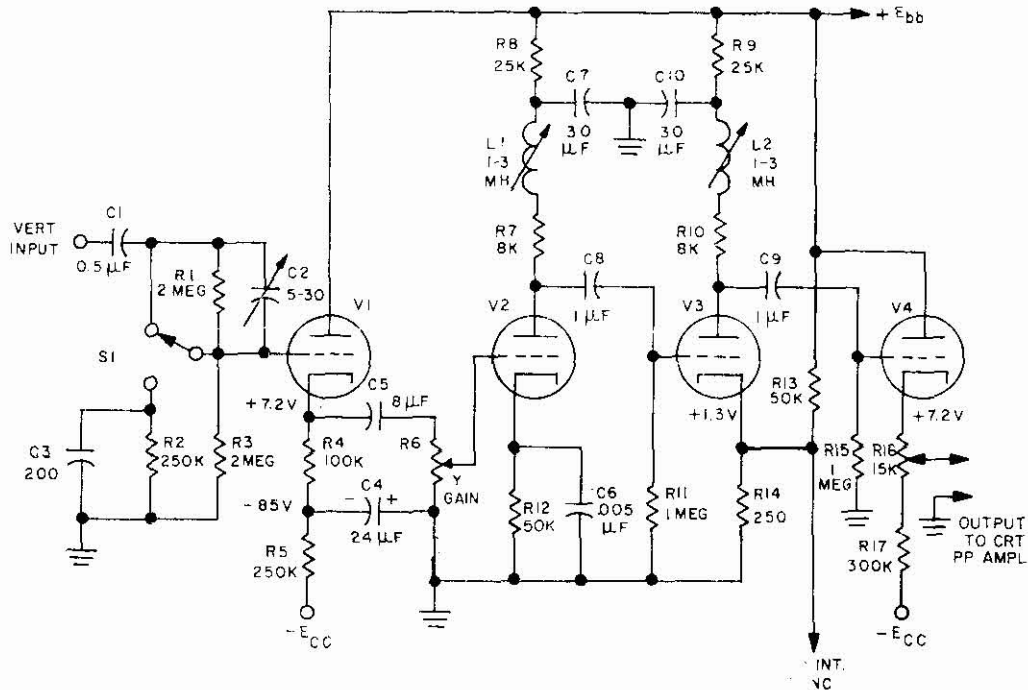

Vertical Deflection Amplifier

(on the order of 1 second). Amplifier V3 is fixed-biased by connecting the cathode to the junction of R13 and R14, which are connected in series between the plate supply and ground. Cathode resistor R14 is also unbypassed so that the circuit is completely degenerative for high and low frequencies, further improving the over-all frequency response. The use of the fixed cathode bias sets the operating point of V3 and helps stabilize the stage. An output from the cathode of V3 is taken for application to the sync circuit for internal synchronization. The output of V3 is fed to cathode follower output stage V4, which is biased positive with respect to ground by plate current flow, even though the cathode is returned to the minus supply. Variable potentiometer R15 serves as an output and positioning control for the following paraphase amplifier. The paraphase amplifier is similar to those described in Section 6; therefore, it is not further discussed here.

FAILURE ANALYSIS.

Beam-Positioning Circuits. Usually, a control circuit failure is indicated by loss of a specific control function, and can be quickly verified by a resistance or voltage check. It must be understood that all controls affect the electron beam in some manner, and that the controls are interacting. For example, increasing the intensity of the beam will also thicken the beam and require a readjustment of the focus control for the thinnest line at that intensity. Like-wise, a change in accelerating anode potential will cause a

change in spot diameter and the maximum intensity available. Where high humidity and excessive moisture prevail, control failures from insulation breakdown, are usually more prevalent because of the high potential involved, which causes a short circuit to ground.

Power Supply Circuits. Because of the high negative potentials used for operation of the CRT electron gun, the oscilloscope power supply is particularly susceptible to flash-over, particularly in damp and humid locations. A voltage check is usually sufficient to reveal the location of the trouble.

Sweep Circuit. Failure of the sweep circuit is evident by a lack of horizontal deflection, assuming that the beam positioning and adjusting circuits operate. A nonlinear sweep produced by changes in value or failure of components will show itself as a crowding together (or an expansion) of the waveform at the ends (or in the middle), particularly when a known linear waveform is observed. Distortion which results from the application of an excessive amplitude of sync pulse to the synchronizing circuit should not be confused with sweep nonlinearity. Most sweep troubles can be corrected by replacement of defective electron tubes, although there may be an occasional component failure. Where thyratron or other gas tubes are used, it may be necessary to try two or three tubes before obtaining one that will operate properly. Even with vacuum-tube sweep circuits, tube selection may be necessary.

Synchronizing Circuits. When the sync pulse amplitude is insufficient, or is of the wrong frequency or polarity, synchronization will not be obtained. With internal synchronization, lack of signal to the synchronizing circuit can occur from poor switching contacts or by failure of any component in the sync circuit. Wrong polarity can occur with external sync, but not with internal sync. Incorrect sync amplitude is compensated for by adjusting the input control. In the case of the controllable sync amplifier, only a shorted or open component or a bad tube can cause difficulty. A resistance check should quickly reveal the trouble. False synchronization is possible with unstable operation due to improper setting of the sync and fine tuning controls. Over synchronization results from too large a synchronizing pulse, and causes distortion of the waveform under view. Reduction of the sync input will return the circuit to normal. The effects of poor voltage regulation may also result in apparent instability, but this is the fault of primary transients rather than sync circuit action. This type of instability is usually recognized easily as it is usually coupled with constant fluctuations of the CRT presentation up or down and to the right or left, or by a constant jittering of the pattern.

Deflection Amplifiers. Lack of output can be caused by failure of components or an electron tube, and can quickly be isolated by using another oscilloscope to check the signal from grid to plate through the amplifier for the point of signal disappearance. In most oscilloscope amplifiers, it is possible to have the circuit operating, but producing false indications because of failure of the compensating

circuits. Use of a square-wave input will quickly determine whether the circuit is rounding off the peaks because of the lack of highs, or drooping at the top because of bad low-frequency response. Comparison of the same waveform on another scope which is in good condition is the best method of determining performance.

SYNCHROSCOPE.

APPLICATION.

A synchroscope is a waveform measuring device very similar to an oscilloscope, only it is used primarily for observing pulse waveforms of short duration.

CHARACTERISTICS.

Vertical Input.

Variable input impedance - may be matched with the output impedance of the signal source.

Vertical input delayed before being applied to vertical plates.

Sync Input.

Variable input impedance

Sweep only generated when a sync signal is present.

Sync signal may be internally or externally originated.

Cathode Ray Tube

Electrostatic - uses medium persistence phosphor.

CIRCUIT ANALYSIS.

General. The following circuits were chosen as basic examples of circuits commonly used in synchrosopes.

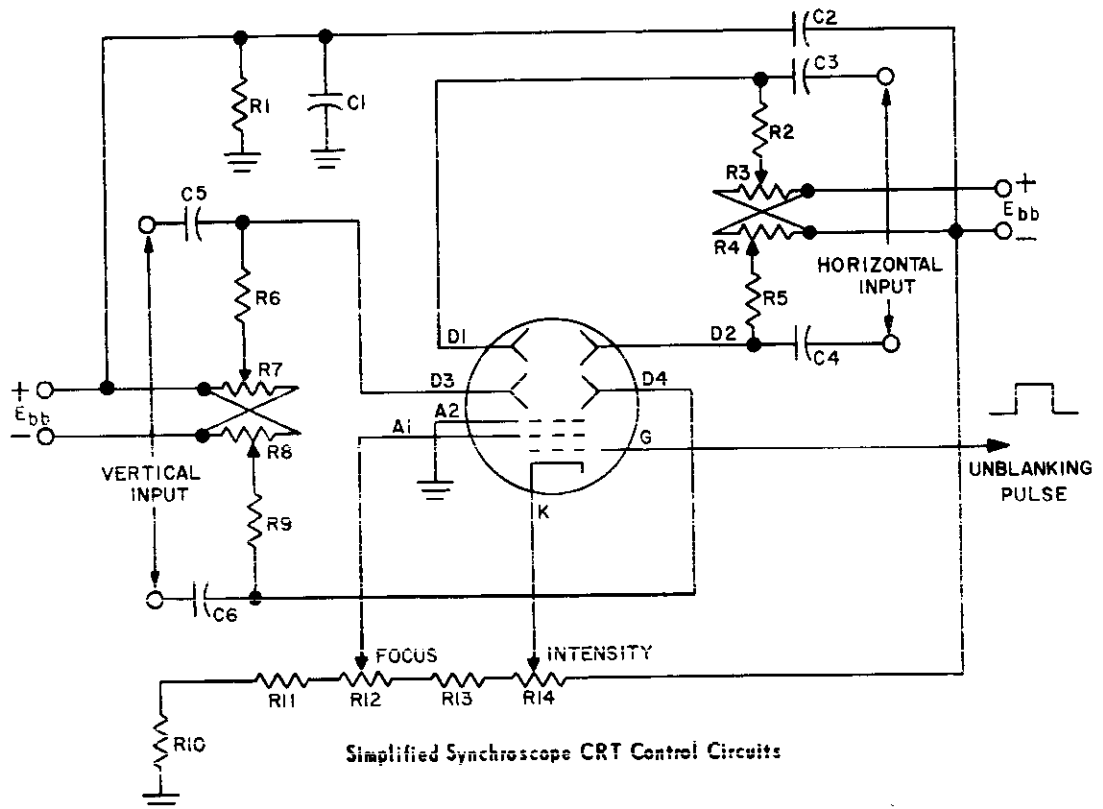

Each circuit was selected to bring out the basic principles and requirements necessary for circuits used in non-repetitive waveform analysis, even though similar circuits may be used in other sections of the manual. The circuit discussion is limited to essentials needed for cathode tube displays.

Beam-Positioning Circuits. A basic beam-positioning system used in a synchroscope, using a balanced deflection network, is shown in the accompanying illustration.

The voltages for the CRT electrodes are taken from a common voltage divider between the negative voltage

supply and ground. The voltage divider is grounded at the positive voltage required for the accelerating anode, while the cathode is operated at a high negative potential with respect to ground, the low voltage is operated above ground. Thus, with the positive low voltage and negative high voltage at above ground potential, the case and chassis can be grounded for the protection of the operator.

It is evident from the schematic that resistors R10, R11, R12, R13, and R14 form a voltage divider from the junction of the negative supply to ground, and at the

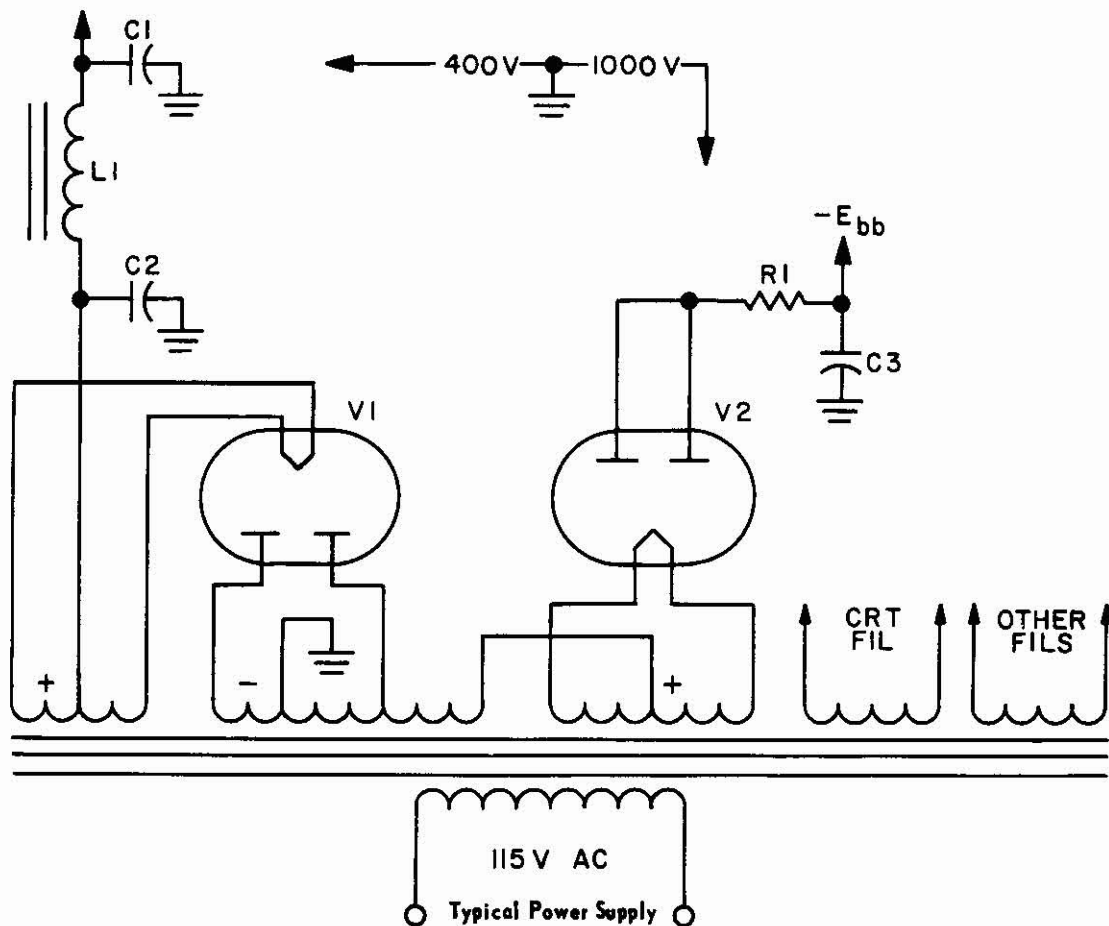

junction of R10 and R11 some positive voltage exists. The control grid is supplied with a positive unblanking pulse, produced by the start-stop sweep generator, which enables the CRT to conduct. As in conventional circuits variation of the voltage on the grid permits the CRT to conduct more or less heavily. Anode no. 1 is connected to a much lower point on the divider; thus it is effectively much more positive than the grid and cathode, and attracts the electrons from the cathode. By varying the d-c potential on this focusing anode, the electron beam from the cathode is directed so that it converges at a point on the face of the CRT. Anode no. 2 of the CRT is grounded; thus, since it is at a more positive voltage than the focusing anode, it attracts the electron beam and accelerates it. The accelerating anode is a concentric ring similar to the

focusing anode, and the focused beam passes through the center, losing only stray unfocused electrons. The second anode current, therefore, is minute and does not detract from the beam. As the beam passes from the accelerating anode to the face of the tube, it passes between two sets of deflection plates. The plates of the set nearest the second anode are positioned horizontally above and below the tube centerline, and deflect the beam vertically. The plates of the second set are nearest the face of the tube, and deflect the beam horizontally.

Each deflecting plate (D1 through D4) is controlled by a separate potentiometer (R3, R4, R7, R8), and the plates are isolated and balanced equally by being connected to the positioning controls through equal resistors R2, R5, R6, and R9. Each plate is also connected to the

deflection amplifiers, through a coupling capacitor, in a push-pull arrangement. Thus the CRT is balanced for dc, for ac, and for any stray capacitance to ground. Since the isolating resistors (R2, R5, R6 and R9) are always of a very large value, the deflecting plates may be connected into any circuit without danger to the operator (it takes a current of only a few microamperes to drop the positioning voltage to zero).

Power Supply. A typical power supply for an elementary synchroscope is shown in the accompanying illustration. Two full-wave rectifier tubes are used with a single transformer to supply positive low voltage for circuits other than the CRT and a negative high voltage for the CRT. The lower-voltage supply is a conventional full-wave rectifier circuit with the center-tap grounded, and B+ is taken from the cathode and applied to a single pi-type C-L filter (C1, L1, and C2). The negative high voltage supply uses the other full-wave rectifier tube (V2), with the plates parallel-connected as a half-wave rectifier, and a low voltage center tap used as a common ground. Because the small amount of current taken by the CRT, the simple R-C filter offered by the bleeder resistor R1 and capacitor C3 is sufficient for hum elimination. The filament windings for the CRT, as well as other tubes, are also included on the same transformer, providing a compact and economical power supply.

Horizontal (Sweep) Channel. There are two types of sync signal input available at the input of the horizontal channel. A positive pulse derived from the signal input may be taken from the coupling amplifier, or some external sync may be applied from an external source.

With the sync switch in the int. sync position, a positive pulse (taken from the coupling amplifier) is applied to the sync pulse amplifier, where it is inverted, amplified, and formed into a sharp spike. The circuit used to develop this spike is shown in the accompanying illustration. The positive pulse is applied through capacitor C1 to triode V1, where it is inverted and amplified at the plate. The variable potentiometer R1 determines the amount of amplification of the signal. The sync pulse is coupled through capacitor C2 and resistor R3, which develops a differentiated form of the negative rectangular pulse. The output is taken from across R3 in the form of a negative spike occurring at the pulse input frequency.

The typical sweep generator is a start-stop multi-vibrator, shown in the accompanying illustration. This circuit is a cathode-coupled type of start-stop multi-vibrator, with the grid of V1 at a high positive potential and the grid of V2 at a high negative bias value, so that V1 is normally conducting heavily and V2 is normally cutoff. With the application of the negative input pulse, V1 is cut off and V2 is brought to maximum conduction for a period of time determined by the time constant of the circuit. This time constant is dependent on the values of R2, C1 and R4, C2. The resulting output, taken from the plate of V1, is a positive rectangular pulse obtained during the time that V1 is not conducting. Besides using the rectangular output for unblanking the CRT during the period

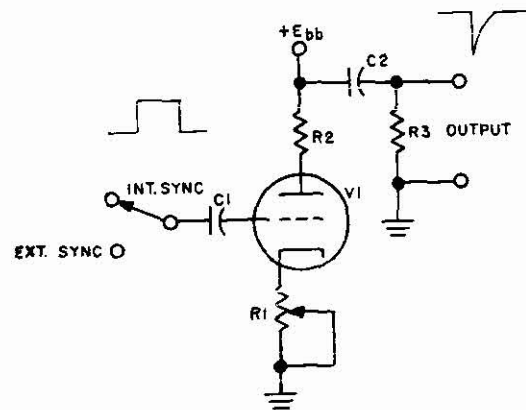

Sync Pulse Amplifier

that the input signal is to be viewed, the rectangular output pulse is applied to an RC circuit (R5 and C3) where it is integrated. A sawtooth output is then obtained from C3, which has the same duration as the unblanking pulse. This sawtooth is applied to drive the output sweep amplifier shown in the accompanying illustration. The output sweep amplifier is a paraphase push-pull type of amplifier which produces a sawtooth waveform from each output, equal in amplitude but of opposite polarity. The single input (driving) sawtooth is applied through C1 to the grid of V1 where it is amplified and inverted. The output of V1 is applied to the grid of V3 and across voltage divider R5 and R6, connected from output to ground. The voltage dropped across R5 is applied to the grid of V2. Since the input of V2 is 180° out of phase with the input of V1, the outputs of V1 and V2 are likewise 180° out of phase. The outputs of V1 and V2 are applied to V3 and V4, respectively, where these outputs are amplified and supplied to opposite horizontal-deflection plates in the CRT to produce a balanced deflection of the electron beam (detailed description of the operation of paraphase amplifiers can be found in section 6 of this Handbook).

Vertical Channel. The signal input is applied to the vertical channel through an input impedance selector circuit, which is used to match the output impedance of the signal source to the input impedance of the coupling amplifier. A typical, simplified, input impedance selector circuit is shown in the accompanying illustration.

This circuit uses a typical tetrode input amplifier, with the input signal being coupled to the control grid of V1 across an input voltage divider consisting of variable resistor R1 and fixed resistor R2. The variable resistor provides both a means of attenuating the input signal, and a method of supplying a variable input impedance for the synchroscope; while fixed resistor R2 determines the mini-

amplifier stage (V2) is provided to supply an additional 180° phase shift, so that the output of stage V2 is in phase

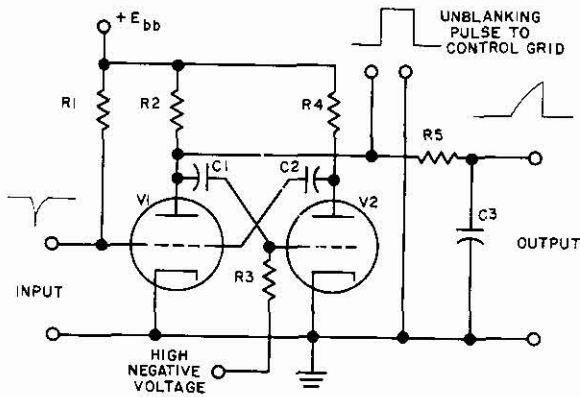

Start Stop Sweep Generator

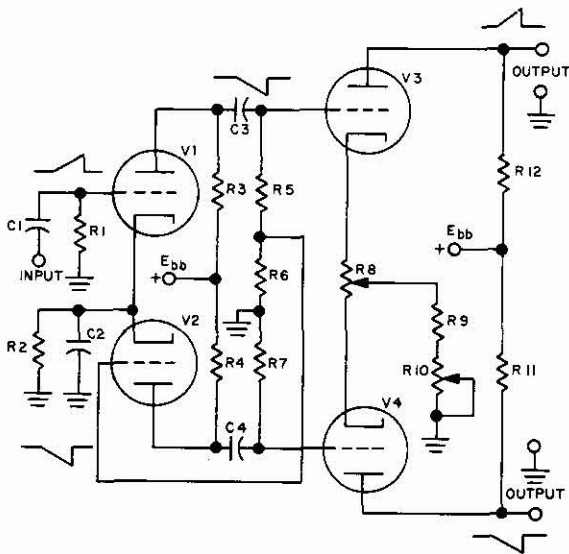

Paraphase Push-Pull Amplifier

imum input impedance to V1. Together this resistive input arrangement facilitates matching the input impedance of V1, to the impedance of the signal source. Resistors R3, R4, and R5 are different values of cathode bias resistors. These different values are selected by a switch to provide a large range of attenuation for the input signal by changing the input bias. Capacitors C1, C2, and C3 are conventional cathode bypass capacitors associated with these cathode resistors. Besides providing a variable input impedance, and a large attenuation range, the input selector circuit provides high amplification with undesired inversion of the input signal at the plate of V1. Therefore, another

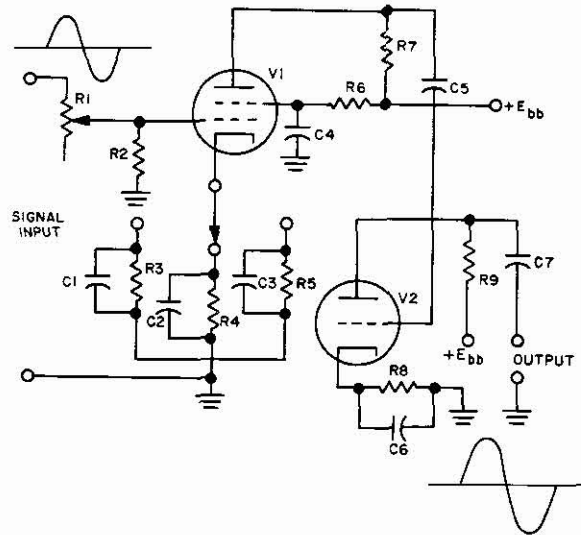

Input Impedance Selector Circuit

with vertical input signal. The output of the input impedance selector circuit is applied to a coupling amplifier.

The coupling amplifier, shown in the accompanying illustration, has two functions.

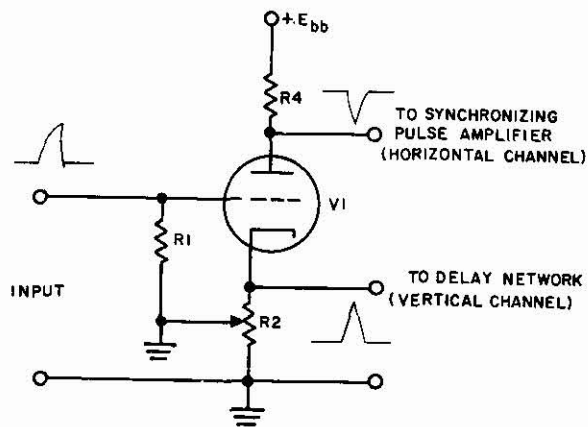

Coupling Amplifier

One function is to supply a pulse to the synchronizing pulse amplifier when internal sync is used. This sync pulse, which is the inverted and amplified input to the

coupling amplifier, is obtained at the plate of V1, and is coupled through an Int-Ext. sync switch to the sync (pulse) amplifier. The pulse then serves as a triquer for the start-stop sweep generator.

The second function of the coupling amplifier is to act as a cathode follower, providing an impedance match for the low-impedance input of the delay network. This input is the uninverted signal pulse obtained at the cathode of V1 without amplification. A potentiometer is used for R2 instead of a fixed cathode resistor. The potentiometer setting determines the amplitude of the pulse obtained at the cathode of V1. This potentiometer functions as a vertical image size control.

The pulse obtained at the cathode of the coupling amplifier is applied to a delay network, which prevents the pulse from causing a vertical deflection of the electron beam until shortly after the sweep has started. (A typical delay time is $1/2 \mu \text{ sec.}$). An accompanying illustration shows a delay network which may be used. It is composed of series inductors and shunt capacitances terminating in a resistor having an ohmic value equal to the total impedance value of the foregoing inductors and capacitors. The delay effect is due to the fact that each capacitor retards the voltage from appearing across it, and each inductor retards the current from flowing through it. The terminating resistor minimizes reflections of standing waves. (Standing waves upset the normal function of the delay line and introduce error).

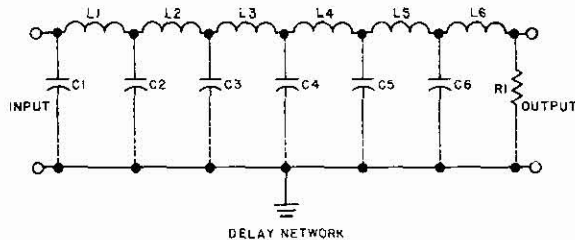

Delay Network

The delayed signal is coupled through a signal attenuator, which is a tapped voltage divider, to the vertical amplifier. A typical attenuator is shown in the accompanying illustration.

This attenuator is frequency compensated to reduce the distributed and stray capacitance of this circuit and the following circuit. Frequency-compensated attenuators further provide the voltage division ratio (resistive and reactive) of the input signal, so that the loss in signal level at the higher frequencies can be compensated for in the following amplifiers. Attenuator compensation is usually effective over the entire useful frequency range of the scope. When a potentiometer type of attenuator is used, the attenuator potentiometer is frequency-sensitive because of the distributed and stray capacitance from the moving arm of the potentiometer, the wiring and circuit

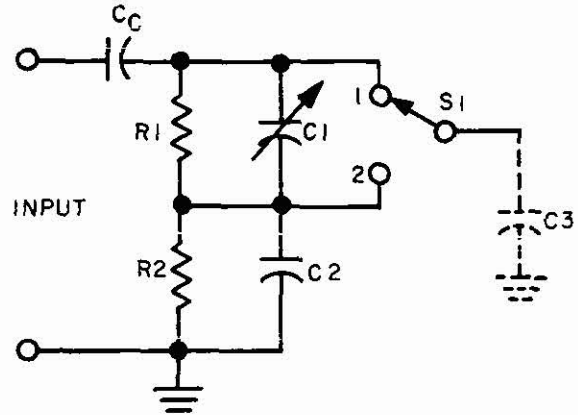

Signal Attenuator

elements, and the electron tube input capacitance to ground. While the resistance of the potentiometer must be as high as possible to maintain maximum input impedance, the greater the resistance, the greater the effect of the stray capacitance. Since there is only one setting of the attenuator arm where the resistance division and the capacitance division are the same ratio, shunt capacitors C1 and C2 are added to the attenuator, as shown in the illustration to provide frequency compensation. When the attenuator (S1) is in position 2, the input to the amplifier is reduced to one-tenth of the total signal across the voltage divider. R2 is then one-tenth of R1 plus R2. The ratio of the capacitive reactance is then chosen to be of the same order. That is, the reactance of C2 and the stray capacitive reactance is, the reactance of C2 and the stray capacitive reactance of C3 is made to be one-tenth of the total reactance of C1 in series with the parallel combination of C2 and C3. Normally, because of the difficulty in measuring the stray capacitance indicated by C3, C1 is made variable and is adjusted during operation to produce the best compensation effects, using a square-wave input (this is made initially and once calibrated requires only an occasional check).

Since most attenuators and amplifiers have reduced high-frequency response because of the shunting effect of stray capacitance, a parallel R-C circuit in series with the input lead is usually inserted to boost the relative response of the attenuator at high frequencies.

A typical three-stage vertical amplifier is shown in the accompanying illustration; it drives a push-pull paraphase deflection output amplifier, similar to the one used as the horizontal sweep amplifier.

Although V1 has its cathode connected to a negative high voltage supply, the plate current flow through R1 and R2 is sufficient to bias the cathode positive with respect to ground. The output of cathode follower V1 is taken

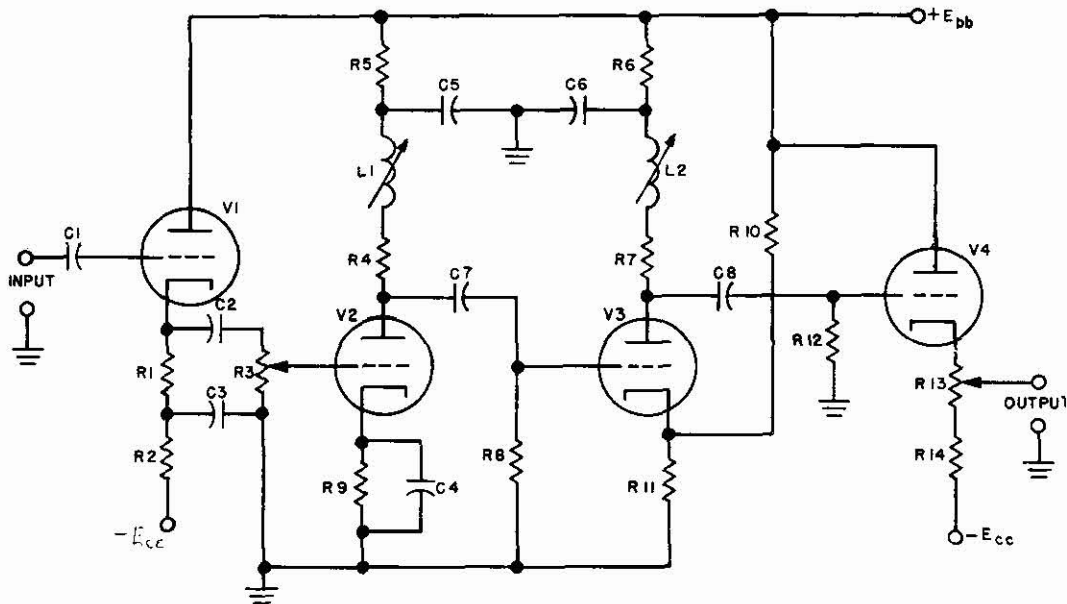

Vertical Amplifier

from the cathode through C2, which is a large value capacitor, and applied to an input gain potentiometer R3. Capacitor C3 is a conventional filter capacitor used to bypass the negative supply. Vertical gain control R3 controls the amplitude of the input signal to the two-stage, high-gain compensated video amplifier consisting of V2 and V3. Both high- and low-frequency compensation are employed in each stage. The cathode of V2 is bypassed by a small capacitor, which makes it degenerative for low frequencies, thus reducing the response and flattening out the low-frequency response. Low-pass R-C filters R5, C5, and R6, C6 offer a high impedance to the low frequencies and a shunt path to the high frequencies in the plate circuits of the amplifier. Thus the effective load impedance at low frequencies is increased, which compensates for the normal drop off, and extends the low frequency response. The high-frequency response is increased by peaking coils L1 and L2, which compensate for the shunting effect of tube and wiring capacitance, providing a reactance which increases with frequency. To help improve the high-frequency response, plate load resistors R4 and R7 are made low in value to reduce the shunting effect of stray capacitance. To improve the low-frequency response, the time constants of R-C coupling networks C7, R8 and C8, R12 are long. Amplifier V3 is fixed-biased by connecting the cathode to the junction of R10 and R11, which are connected as a voltage divider in series between the plate supply and ground. Cathode resistor R11 is also unbypassed so that the circuit is completely degenerative for high and low frequencies, further improving the over-all frequency

response. The use of a fixed cathode bias sets the operating point of V3 and helps stabilize the stage. The output of V3 is fed to cathode follower output stage V4, which is biased positive with respect to ground by plate current flow, even though the cathode is returned to the minus supply. Variable potentiometer R13 serves as an output and positioning control for the following parapsphere amplifier.

FAILURE ANALYSIS.

Beam-Positioning Circuits. Usually, a control circuit failure is indicated by loss of a specific control function, and can be quickly verified by a resistance or voltage check. It must be understood that all controls affect the electron beam in some manner, and that the controls are interacting. For example, increasing the intensity of the beam will also thicken the beam and require a readjustment of the focus control for the thinnest line at that intensity. Likewise, a change in accelerating anode potential will cause a change in spot diameter and the maximum intensity available. Where high humidity and excessive moisture prevail, control failures from insulation breakdown are usually more prevalent because of the high potential involved, which causes a short circuit to ground.

Power Supply Circuits. Because of the high negative potential used for operation of the CRT electron gun, the synchroscope power supply is particularly susceptible to flash over, particularly in damp humid locations. A voltage check is usually sufficient to reveal the location of the trouble.

Horizontal (Sweep) Channel. A failure in the hori-

zontal channel can be due to a failure of any of the individual circuits comprising the channel as well as two circuits within the vertical channel. If the input impedance selector and the coupling amplifier, the two circuits within the vertical channel, are the cause of the sweep failure; the vertical deflection will also be defective as well as the sweep. If this is the case, voltage and waveform checks, made by a voltmeter and an oscilloscope will reveal the location of the faulty component within the two circuits. If, however, there is no trouble with the vertical deflection and faulty sweep exists, the trouble exists within the three horizontal channel circuits. Beginning with the sweep amplifier, the inputs should be checked with a voltmeter and an oscilloscope. If the proper input exists the trouble is within this circuit. If an improper input exists check the input of the start-stop sweep generator with an oscilloscope. If the input is proper the trouble must exist in the start-stop sweep generator. Voltage and waveform checks with a voltmeter and an oscilloscope will reveal the location of the faulty component. If the input to this circuit is proper, check the input to the sync (pulse) amplifier. If the coupling amplifier is working properly and the sync selector switch is functioning properly, the trouble should be within the sync (pulse) amplifier. Voltage and waveform checks with a voltmeter and oscilloscope will reveal the faulty component.

Vertical Channel. A failure in the vertical channel is characterized by improper amplitude of the presentation of the pulse on the synchroscope screen. There are six circuits which could result in the vertical channel failure. Two of these, the input impedance selector, and the coupling amplifier, produce sweep failure. The trouble shooting of these circuits has already been mentioned. The other four circuits of the vertical channel, the push-pull paraphase amplifier, the vertical amplifier, the signal attenuator, and the delay network, affect only the vertical display of the scope. If the failure exists in the delay network, the vertical deflection will not occur at the proper time interval with respect to the sweep. If this effect is apparent on the display, check the delay network with an oscilloscope to determine where the improper waveforms or voltages exist. If the failure exists in the push-pull paraphase amplifier the vertical position of the display on the CRT screen is improper. If this is apparent on the display check the voltages and waveforms of the push-pull paraphase amplifier with an oscilloscope to determine where the faulty component is located. If these circuits of the vertical channel have been checked and found to be operating properly, and trouble still exists in the vertical display, the trouble must exist in the signal attenuator or the vertical amplifier. To determine where the trouble exists check the appropriate voltages and waveforms with an oscilloscope.

CRT DISPLAY CIRCUITS.

The CRT display supplies a visual indication of any signals which are applied to the CRT. One of the most

important uses to which cathode-ray-tube displays and their associated circuitry are applied is the location of objects or targets in space. This is the prime purpose of radar. Generally speaking, there are two types of radar systems; the pulsed radar system, and the continuous wave radar system. Since continuous wave radar systems are very rarely used, the discussion in this section is limited to displays associated with pulsed radar systems.

The display units used in pulsed radar are either deflection modulated or intensity modulated. These terms describe the method by which the echo signal affects the trace on CRT. In deflection modulated displays, the input signal, after being detected and amplified, is applied to the deflection system of the CRT, and shows up as a pulse or pip on a circular or single horizontal sweep line. Typical radar displays of this type are the A-scope and the J-scope. In intensity-modulated systems, the echo is fed to an intensifying circuit, which changes the bias on the control grid of the CRT. The control grid is normally biased at cut-off. When the signal is received, it causes the bias on the control grid of the CRT to become less negative, thereby increasing the density of the electron beam and the intensity of the trace. Typical radar displays of this type are the B-scope and the C-scope.

APPLICATION.

The A, B, C, and J-scope type CRT presentations are relatively simple radar displays used for the purpose of locating the position (range and bearing) of a target with respect to the position of the radar.

CHARACTERISTICS.

A-Scope and J-Scope presentations use deflection modulated displays.

A-Scope and J-Scope presentations use single line displays.

A-Scope and J-Scope presentations show only one component of location (usually direction).

B-Scope and C-Scope presentations use intensity modulated displays.

B-Scope and C-Scope presentations form rectangular field displays.

B-Scope and C-Scope displays show two components of location (usually direction and range)

A-scope, J-scope, C-scope and D-scope displays are usually designed to use electrostatic deflection systems.

CIRCUIT ANALYSIS.

General. The A-, B-, C-, and J-Scope displays constitute the most commonly encountered types of radar displays employing electrostatic type cathode ray tubes. They respond to the reception of echoes of signal pulses striking specific targets, and present these echoes as pips or illuminated targets on the trace of the display, indicating location of targets through the time relationship of the echo signals compared with the sweep signals.

The typical A-scan is shown in the accompanying illustration. It consists of a single horizontal line with a

transmitted pulse identification, representing the beginning of the sweep, and echo pulse indications, representing targets. The transmitted pulse indication has an amplitude greater than any of the other echo pulse indications.

The A-Scope is primarily used in conjunction with other radar indicators, since the A-Scope can only locate the range of a target. The A-Scope is particularly used in artillery fire control because of the accuracy of its range determination. The A-Scope is also used as a test instrument to observe video input signals during the testing and alignment of radar receivers.

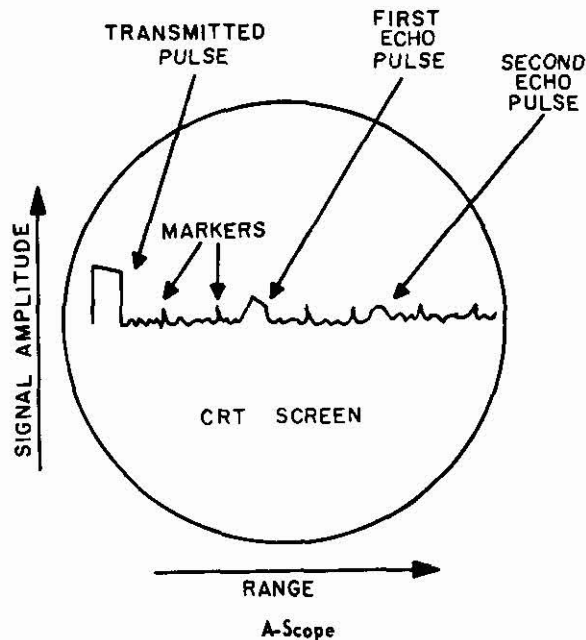

A typical J-Scan is shown in the accompanying illustration. It consists of a single circular trace line, which remains at a relatively constant distance from the center of the CRT face. A main pulse indication on the circular trace indicates the beginning of the sweep, and the echo pulses are located somewhere along the circumference of this circle. The distance between the echo pulse and the main-pulse along the circumference of the circle, indicates the range of the target. A calibrated range ring is used to measure the distance along the circular trace.

The J-Scope is used in radar for extremely accurate range determination of a particular target. In the laboratory, the J-Scope is applied to the measurement of very short time intervals.

A typical B-Scan is shown in the accompanying illustration. It consists of a rectangularly scanned field made up of parallel vertical trace lines, with the center line of the field representing zero azimuth (dead ahead) position. The radar location is at zero azimuth position on the hori-

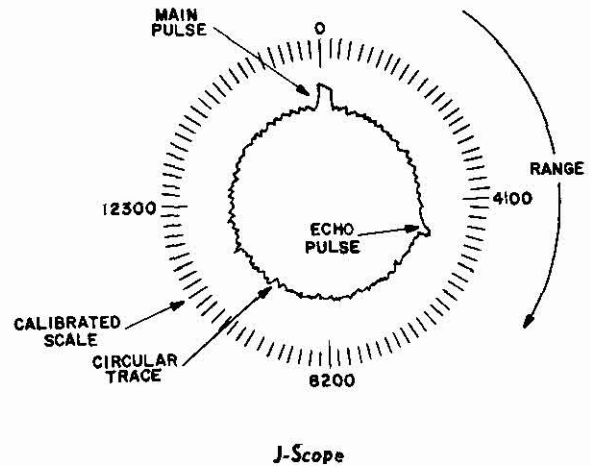

zontal base line. Any targets which appear to the right or left of this center line are actually located to the right or left of the ship or radar center line, at the vertical distance shown.

The B-Scope is used in radar systems for continuous scan of an assigned area, chiefly for ground (or sea) targets in a limited sector.

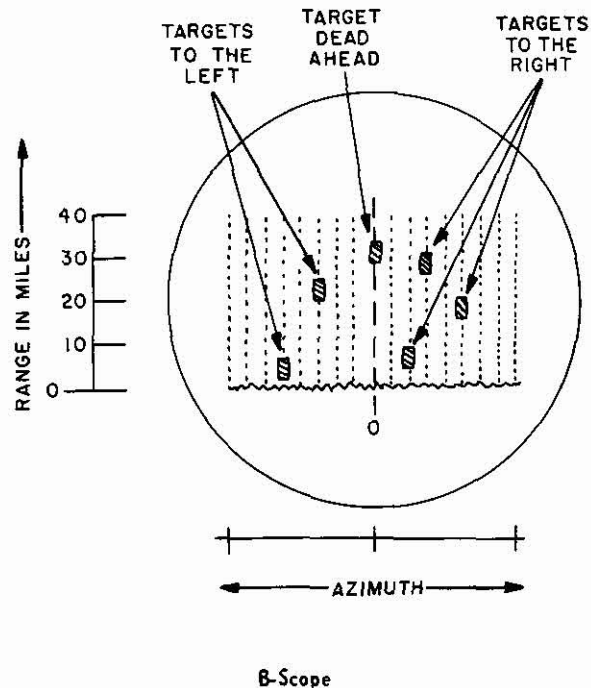

A typical C-Scan is shown in the accompanying illustration. It consists of a rectangularly scanned field made

up of a number of parallel horizontal lines; the center vertical line which bisects the horizontal length of the field represents zero azimuth position, while the center horizontal line which bisects the vertical length of the field represents zero elevation position. All vertical positions above the zero elevation position represent a positive elevation, and all vertical positions below the zero elevation represent a negative elevation.

The C-Scope is used in radar systems for continuous scan of an assigned area, chiefly for aircraft interception and beam landing.

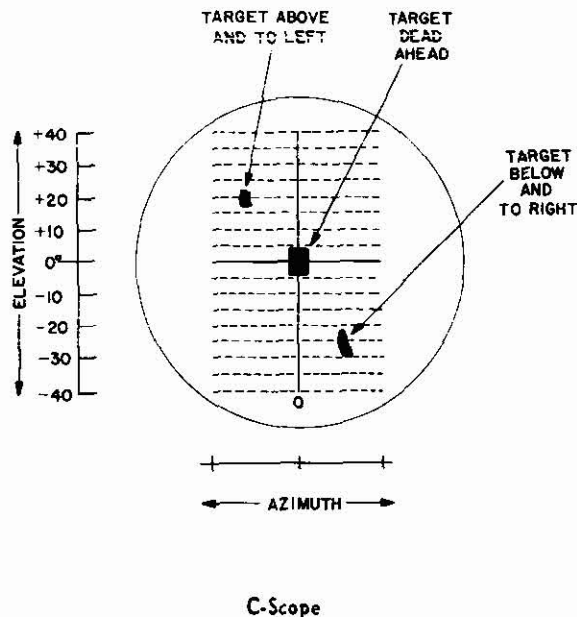

Circuit Operation. The A- and J-Scopes are similar in that the signal is obtained from the radar receiver and applied through vertical amplifiers to the vertical deflection elements of the CRT. The manner in which each type of scan accomplishes the sweep, however, is different.

A typical A-Scope arrangement is shown in the accompanying block diagram.

In the A-Scope arrangement a trigger signal is fed to the trigger amplifier stage, simultaneously, the received echo signal is applied from the radar receiver through the vertical (video) amplifier to the CRT. The trigger for starting the sweep may come from either the timer within the indicator or from the transmitter. The trigger amplifier both amplifies and sharpens the trigger pulse, which is then applied to the triggered sweep generator where a sawtooth voltage is produced and applied to the horizontal deflection plates. The resultant sweep produces a straight horizontal trace line on the CRT. With the application of the received echo signal, a vertical deflection in the form of a pip appears located somewhere along the horizontal trace. The distance between the radar antenna and the

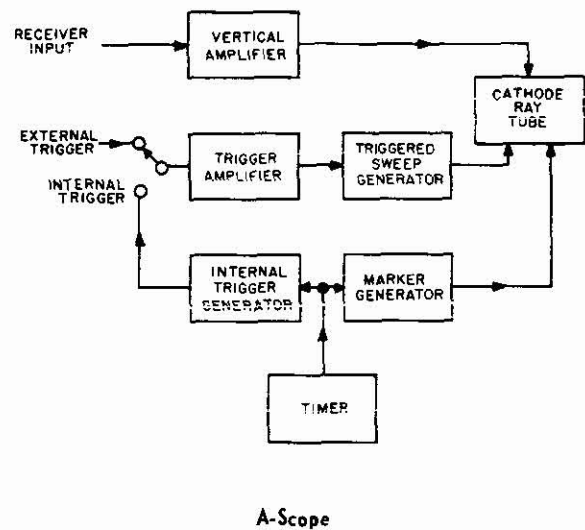

target is indicated by the linear position of the pip on the trace. Some of the pulse voltage of the transmitter is impressed directly upon the receiver, and produces a large pulse on the extreme left of the CRT trace. All distances are measured relative to this pulse. To facilitate the measurement of the distance of the echo pip from the zero reference point (transmitter pulse), calibrated markers generated by the marker generator stage are also applied to the CRT. Thus by counting the number of markers between the transmitted signal and the received echo, target distance is quickly determined.

A typical J-Scope is shown in the corresponding block diagram. A crystal oscillator and a phase-shifting network furnishes two sine-wave voltages, 90° out of phase, to both sets of CRT deflection plates to produce a circular trace. The trigger and sweep circuits blank out the tube, intensifying the electron beam only during the active sweep time. The J-Scope display is the same as the A-Scope display, except that the J-Scope uses a circular sweep rather than a linear sweep. Time and range measurements on the J-Scope are more accurate than those of the A-Scope since the J-Scope scan is longer. The target echoes are indicated as radial pips or pulses pointing away from the center of the CRT. To produce these pips another CRT electrode is introduced. This electrode is a thin metallic rod inserted through the face of the tube, almost reaching the deflection plates. The echo signals then are applied to this center electrode from the vertical amplifier.

The B-Scope and the C-Scope, like the A- and J-Scopes are mostly similar in their mode of operation. The B-Scope and the C-Scope both use intensity modulated displays, that is the echo signals appear as bright patches against a dark background. Intensity modulation is produced by applying the amplified echo signals to either the control grid or the cathode of the CRT. In both the B-Scope and the

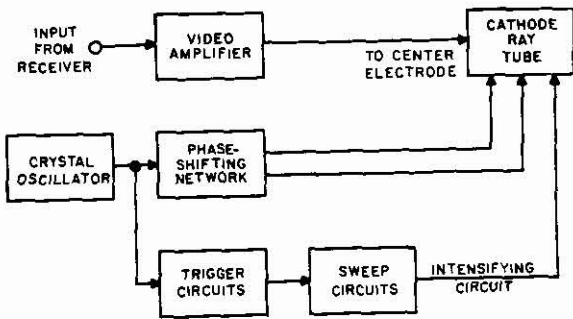

J-Scope

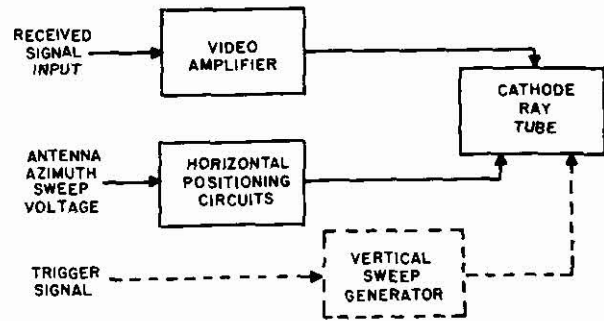

B-Scope and C-Scope

C-Scope, the sweep scans a rectangular area on the screen of the CRT. Also, in both the B-Scope and C-Scope, the horizontal axis always represents azimuth. On the other hand, the vertical axis on the B-Scope represents range while the vertical axis on the C-Scope represents elevation. The block diagram of a typical B-Scope and a typical C-Scope arrangement is shown in the corresponding block diagram. The only difference in the circuitry between them is the omission of the vertical sweep generator in the C-Scope. The vertical deflection circuits of the B-Scope are driven by a linear timebase signal from a sweep generator. This sweep is initiated by a sync signal from the central timing circuits of the radar. The vertical deflection circuits of the C-Scope are driven by a sweep voltage from a variable potentiometer connected the radar antenna.

The horizontal-deflection circuits of the B-Scope and C-Scope are the same type of circuits as those used for the vertical-deflection system of the C-Scope. The horizontal motion of the antenna is translated into a regularly varying (sweep) voltage which produces the horizontal sweep for the cathode-ray tubes.

The electrostatically deflected CRT common to the A-, B-, C-, and J-Scopes is shown in the following illustration with its accompanying control circuitry. The rod shaped dotted lines, extending from the face of CRT almost to the deflection plates represents the electrode used only in the J-Scope to which negative video (echo) signals are coupled. This electrode causes the electron beam to be deflected radially outward in accordance with the incoming signals.

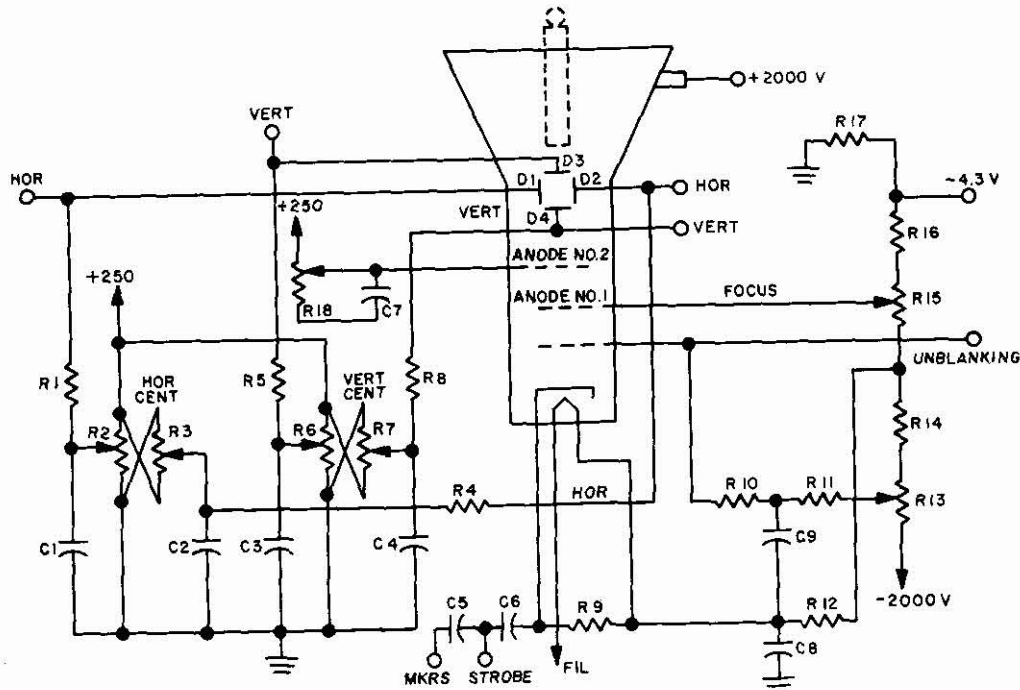

Electrostatic CRT Used in A-, B-, C-, and J-Scopes

It is evident from the schematic that resistors R9, R10, R11, R12, R13, R14, R15, R16, R17 form a voltage divider network. The cathode of the CRT is connected at a less negative point on the divider than the grid, the grid is negative with respect to the cathode, and is adjustable by means of potentiometer R13. R13 then, as in conventional circuits, permits the tube to conduct more or less heavily. This is the intensity control. Anode no. 1 is connected to a much lower point on the divider through potentiometer R15; thus it is effectively less negative than the cathode and grid, and attracts electrons from the cathode. This is the focus control. By varying the d-c potential on this control, the electron beam from the cathode is directed so that it converges at a point on the face of the CRT. Anode no. 2 is at a positive potential and as anode no. 1 attracts electrons from the cathode. It provides the function of acting as an auxiliary focus control and an accelerating anode. As the beam passes from the accelerating anode to the face of the tube, it passes between two sets of deflecting plates. The horizontally positioned plates deflect the beam vertically and the vertically positioned plates deflect the beam horizontally.

A balanced deflection system is used for this cathode-ray tube. Each deflecting plate (D1, D2, D3, and D4) is controlled by separate dual potentiometers (R2, R3, R6 and R7, respectively), and the plates are isolated and balanced equally by being connected to the positioning controls through equal resistors R1, R4, R5, and R8. A-C balance is provided by capacitors C1, C2, C3, and C4. Since the isolating resistors R1, R4, R5 and R8 are always a very large value, the deflecting plates may be connected into any circuit without danger to the operator.

FAILURE ANALYSIS.

Cathode-Ray Tube. Usually, a control circuit failure in the CRT is indicated by loss of a specific control function, and can be quickly verified by a resistance or voltage check. It must be understood that all controls affect the electron beam in the same manner, and that the controls are interacting. For example, increasing the intensity of the beam will also thicken the beam, and require readjustment of the focus control for the thinnest line at that intensity. Likewise, a change in the accelerating anode potential will cause a change in spot diameter and the maximum intensity available. Where high humidity and excess moisture prevail, control failures from insulation breakdown are usually more prevalent because of the high potential involved, which causes a short circuit to ground.

It is found that all of the voltages on the CRT electrodes are proper the CRT must be the defective component. If, however, the voltages on the CRT electrodes are not proper, and the associated control circuitry is checked and found to be proper and the power supply is functioning properly, the fault must exist in some stage preceding the electrode with the improper voltage on it. It is also possible to determine the area of the fault by the CRT indications.

In the A-Scope, if the improper voltage or waveform exists on the horizontal deflection plates and the CRT indication shows that there is an improper or no horizontal sweep, check the input of the triggered sweep generator with an oscilloscope. If it is correct the fault lies in this circuit. If the voltage is incorrect, check the input of the trigger amplifier with an oscilloscope. If the trigger amplifier input is correct the faulty component is in this stage. If the input is incorrect and an external trigger is used the fault is in this external source. If, however, the input of the trigger amplifier is incorrect and the trigger is obtained from the internal trigger generator, check the input to the internal trigger generator with an oscilloscope. If the voltage or waveform applied to the internal trigger generator is improper the fault should be in the timer. If the CRT display indicates that only the range markers are missing the trouble must be in the marker generator.

If the improper voltage or waveform is present on the vertical deflection plates the trouble must be in the vertical amplifier or circuitry prior to the A-Scope indicator. Check the input of the vertical amplifier with an oscilloscope. If it is correct the fault is within this circuit.

In the J-Scope, if circular trace is improper and improper voltages or waveforms exist on the vertical and horizontal deflection plates, check the input of the phase shifting network with an oscilloscope. If the input is proper the fault is in this circuit. If, however, the input is improper the fault is the crystal oscillator. If the intensity of the display is improper and the voltage existing on the control grid is improper, check the input of the sweep circuits. If the input is proper the fault is in these circuits. If the input is improper the fault must be in the trigger circuits. If the improper signal exists on the center electrode of the CRT and if the video signal on the display is incorrect, check the input of the video amplifier with an oscilloscope. If the input is proper the fault is within the video amplifier. If the input is improper the fault must be in the radar receiver.

In the B- or C-Scope, if the voltages or waveforms on the horizontal plates are improper, or if the horizontal trace is improper check the input to the horizontal positioning circuits with an oscilloscope. If the input is correct the failure is in the horizontal positioning circuits. If the input is improper, the failure is in the antenna azimuth sweep voltage. If the voltages or waveforms on the vertical plates of the B-Scope are improper, or if the vertical trace is improper check the input of the vertical sweep generator with an oscilloscope. If the input is proper the failure is in the vertical sweep generator. If the input is incorrect the failure is in the trigger source. If the voltages or waveforms on the vertical plates of the C-Scope are improper, or if the vertical trace is improper, the antenna voltage must be incorrect. If the target echo signals are not present on the control grid of the CRT, check the input to the video amplifier stage or stages with an oscilloscope. If the input is proper the fault is within these stages. If the input is improper the failure is in the radar receiver.

ELECTROMAGNETIC CATHODE-RAY TUBE.

A cathode-ray tube is an electron tube in which the electrons trajectory from the cathode toward an anode are focused into a concentrated beam which eventually strikes the luminescent screen. This beam is varied in position and intensity which produces a visible pattern on the screen. An electromagnetic cathode ray tube utilizes magnetic fields to provide a means of focusing and deflecting the electron beam.

Electromagnetic cathode-ray tube circuits are preferred where the cathode ray tube (commonly referred to as CRT) is to have a large screen diameter. The electromagnetic CRT has several advantages over the electrostatic tube. Some of these advantages are that: a well focused electron beam of higher current density can be produced; greater accelerating voltages can be used to obtain brighter screen patterns without as great a reduction in the deflection sensitivity of the tube; the structure of the electron gun is simpler and more rugged; and the over-all length of the envelope is shorter.

A pictorial representation of the electromagnetic CRT is shown in the accompanying illustration.

The electromagnetic CRT uses a triode type gun. It consists of an indirectly heated cylindrical cathode closed off at one end by a small plate, which is coated with barium and strontium oxides. The oxides emit a large number of electrons. A twisted heater element is contained within the cylindrical cathode to bring the cathode to the operating temperature. The control grid is also a cylinder, which surrounds the cathode cylinder. It contains a baffle with a tiny aperture of smaller diameter than the emitting surface of the cathode, which is located very close to the aperture. Beyond the control grid is a hollow cylinder which contains several baffles and which has its circumference around the same axis as the control grid. This cylinder is the accelerating anode which is connected to a

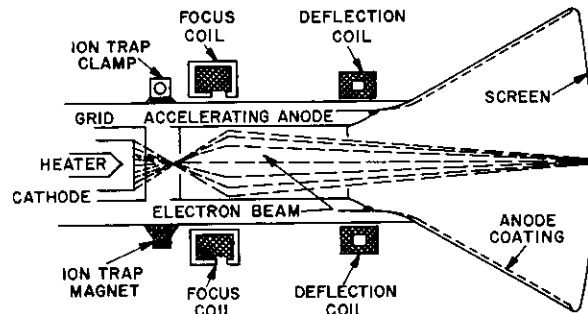

Electromagnetic Cathode Ray Tube

conductive coating within the tube. This coating acts as an extension of the accelerating anode and as an electrostatic shield. There is no second anode for focusing as there is in the electrostatic CRT. Instead, an external focusing coil encircles the neck of the tube and magnetically focuses the electron beam. The complete focusing system is composed of two lenses, one is produced by the electrostatic field between the control grid and the following electrode. This electrostatic field causes the electron beam to converge at a point some distance before the magnetic field of the focusing coil which acts as the second lens. After the electrons travel beyond the convergent point they again begin spreading until they enter the magnetic field of the focusing coil, where the reaction causes the electrons to later converge at the phosphorescent screen, if the position of and the current through the coil are correct. The position of this external focusing coil is not only capable of being varied along the neck of the tube, but the physical construction of the coil also permits one side of it to come in closer proximity to the tube than the other. This characteristic of the focusing coil provides a means of centering the electron beam as well as focusing it.

The method of accomplishing horizontal and vertical deflection also relies on an external electromagnetic force. This electromagnetic force is provided by a set of coils, which encircle the neck of the CRT and is located after the focus coil. Usually four deflection coils are used. Two of these are wired in series and are mounted in such a way as to produce a magnetic field whose lines of force run vertically through the neck of the tube. This vertical magnetic field causes horizontal deflection of the electron stream. The other pair of coils is wired in series and mounted in such a way as to produce a magnetic field whose lines of force run horizontally through the neck of the tube. This horizontal magnetic field causes a vertical deflection of the electron stream. A current is used to activate the coils and produce the magnetic fields at right angles to the electron movement. The amount of deflection that may be

obtained is dependant upon: accelerating anode voltage, distance between the screen and the deflection coils, length of the magnetic field, and the strength of the magnetic field. These deflection coils are contained in a mounting and called the deflection yoke. The position of the deflection yoke, like the position of the focus coil, can be shifted along the neck of the tube to vary the amount of deflection. The deflection yoke can also be rotated about the neck of the tube. This property permits the visual pattern or raster to be centered squarely on the screen.

Another element used on an electromagnetic CRT is called the ion trap. It removes a problem that is specifically peculiar to the electromagnetic CRT. Negative ions exist in the CRT as a result of the bombardment of the residual gas or tube electrodes by the emitted electrons. This condition is of no consequence in an electrostatic CRT since electrostatic focusing networks can focus the ions along with the electrons. In the electromagnetic CRT, however, the greater mass of the ion prevents proper focusing and deflection of these ions. The result is a constant bombardment of the screen at one particular spot, causing the gradual deterioration of the phosphorescent material at this point and a dark spot on the screen. There are several types of ion traps that may be used. One type consists of a modified electron gun arrangement and a permanent bar magnetic unit which is slipped around the neck of the tube close to the electron gun. Although it is not shown in the illustration, the gun is made to produce a bent electrostatic field that carries both ions and electrons toward the accelerating anode. The ion-trap magnet affects only the electrons in this combined beam in such a way that they change their direction of motion and return toward the main axis of the tube. In this manner only the electrons strike the screen, while the ions strike the anode and are removed.

The types of scan and circuits used with the electromagnetic CRT are described in following paragraphs in this section.

PLAN POSITION INDICATOR.

APPLICATION.

The plan position indicator (or PPI) type of radar display is used when it is desired to track objects on a 360° polar map giving range and azimuth. This map can easily be correlated with standard maps, since, not only the target but also physical features of the area are made apparent.

CHARACTERISTICS.

- Uses electromagnetic CRT.
- May use rotating or stationary deflection yoke.
- PPI CRT uses high persistence phosphor.
- PPI utilizes intensity modulation.
- Antenna and sweep trace are synchronized.
- Center of sweep represents radar location.
- Sweep starts at the center and moves radially outward.

Angle of target from heading represents bearing of target.

Distance of target from center of sweep represents range of target.

CIRCUIT ANALYSIS.

General. The plan position indicator is a type of radar display which utilizes an electromagnetic CRT. A high persistence phosphorescent material is used on the face of the CRT, which permits the glow produced by the electron bombardment to remain for a relatively long period of time. Signals reflected from targets are taken from the radar receiver and applied to the control grid of the CRT, via limiting and amplifying circuits, during the sweep time of the beam. Intensity modulation of the electron beam occurs in accordance with the amplitude of the received echoes, which produce corresponding bright portions on the screen.

The distance that the brightened portion of the trace is from the origin of the sweep, is the range of the target. The angle that is made by the brightened portion of the trace with respect to the zero degree radius of the sweep constitutes the bearing (or azimuth) of the target. This type of display also permits an operator to locate a target with respect to the position of physical features of an area, which are shown on the display in the form of a polar map.

The rotating sweep which characterizes the polar map display is produced by a magnetic deflection field rotating in synchronization with the radar antenna. This may be accomplished by a mechanical azimuth sweep (rotating deflection yoke) or electrical azimuth sweep (stationary deflection yoke).

A pictorial representation of a typical PPI display is shown in the following illustration.

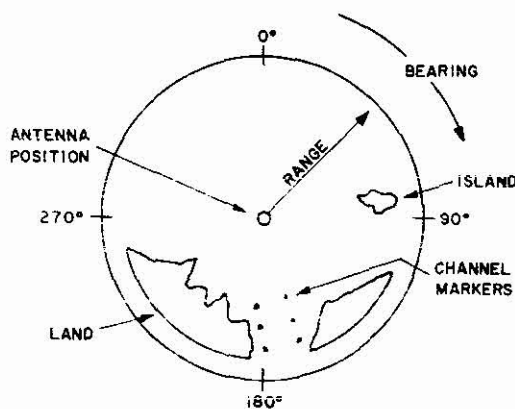

Typical PPI Display

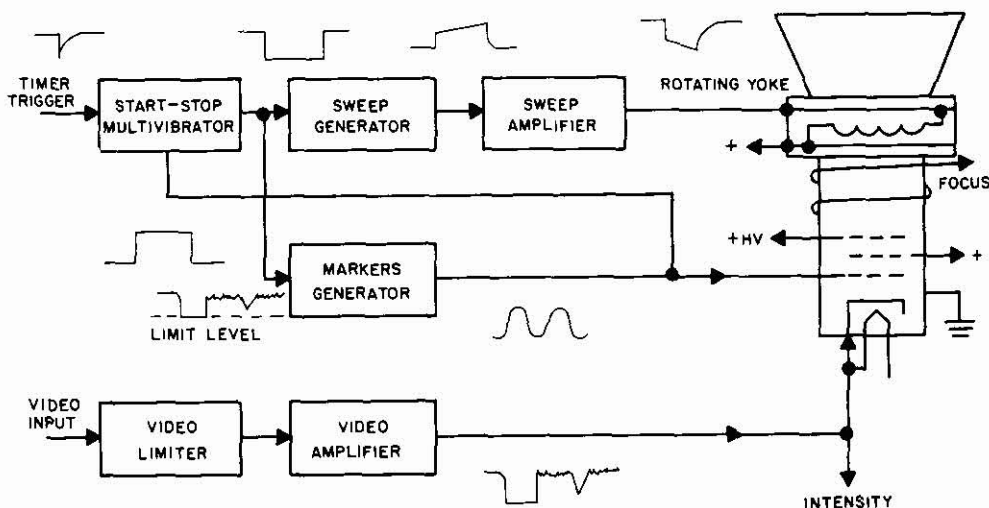

Simple PPI-Scan Block Diagram

Circuit Operation. The circuits used in the discussion of circuit operation are typical circuits used in PPI display, but do not represent every circuit that could be used in PPI displays. A block diagram of a simple PPI display is shown in the accompanying illustration with corresponding waveforms. An analysis will be made of the operation of each representative circuit corresponding to the block diagram.

The timer trigger is a negative pulse obtained from the timing circuits, and used to actuate the start-stop multivibrator. The multivibrator produces negative gate signals which are applied to the sweep generator and the marker generator, and a positive gate signal which is applied as an unblanking gate to the control grid of the CRT. A typical start-stop multivibrator is shown in the accompanying illustration. Resistors R1 and R2 are grid bias resistors for triodes V1 and V2, respectively. Resistors R3 and R4 are the plate resistors for V1 and V2, respectively. Capacitor C1 couples the grid of V1 to the plate of V2. Capacitor C2 couples the grid of V2 to the plate of V1.

Normally, triode V1 is conducting due to the positive bias applied on the grid of V1. At the same time, triode V2 is normally cut off due to the fixed negative bias applied to the grid of V2. A negative pulse applied to the grid of V1 reduces the conduction of V1, causing the plate voltage to increase. The positive plate voltage swing of V1 drives the grid of V2 into conduction, thereby decreasing the plate voltage of V2. This decrease (negative swing) in the plate voltage of V2 is fed back to the grid of V1 and drives V1 into cutoff. The circuit now rests in the opposite condition with V2 conducting heavily and V1 cut off. During this period the flat portion of the output pulse is generated. Since capacitor C1 is connected to the positive supply through R1, it eventually develops a positive charge

which is sufficient to bring the grid of V1 above cutoff. Once again V1 conducts and the negative plate swing is coupled to the grid of V2 through C2, driving V2 towards cutoff and producing the trailing edge of the square wave as its plate voltage rises. Eventually, V1 is brought to the state of maximum conduction and V2 is brought to cutoff, where the circuit stabilizes due to the positive biasing voltage on the grid of V1 and the high negative bias voltage on the grid of V2. Another negative pulse must be applied to the grid of V1 in order to change the conduction states of V1 and V2.

From the description of the circuit operation of the start-stop multivibrator it can be seen that with the application of one negative timer pulse to the input, one negative rectangular pulse is obtained at the plate of V2. This negative rectangular pulse is used to operate the sweep generator and the marker generator. At the same time, a positive rectangular pulse is taken from the plate of V1 and is applied to the control grid of the cathode ray tube for unblanking use.

The typical sweep generator, which receives the negative rectangular pulse from the start-stop multivibrator, produces a trapezoidal sweep. The following schematic is that of a typical sweep generator circuit. The negative rectangular pulse is applied to the grid of triode V1, which acts as a high speed switch. Resistor R1 is the plate resistor of V1. R1 is also part of an r-c network, which determines the amplitude of the leading edge and the slope of the trapezoidal waveform, when V1 is cutoff. Resistor R2 is also part of the r-c network when V1 is cutoff. Its value also affects the amplitude of the leading edge of the trapezoidal waveform. Capacitor C1 is the capacitive part of the r-c network. Its value affects the slope of the trapezoidal waveform.

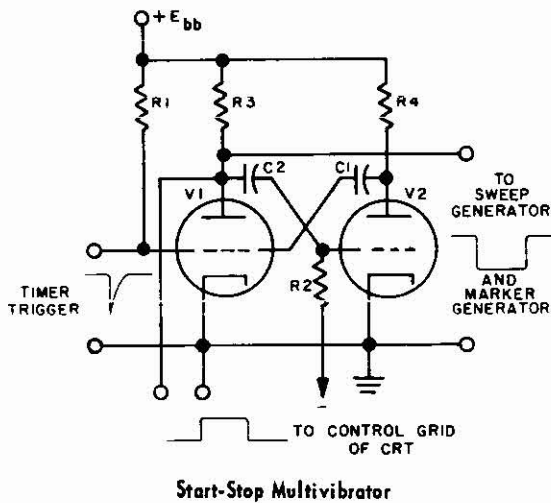

Start-Stop Multivibrator

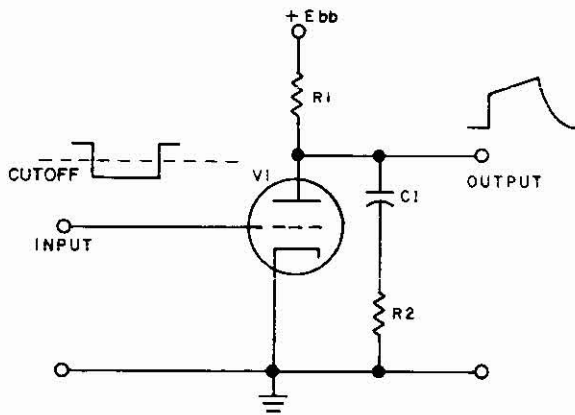

Sweep Generator

When no rectangular pulse is applied to the input, triode V1 is conducting and effectively shunting R2 and C1. As the negative rectangular input pulse is applied to the grid of V1, conduction of V1 ceases and the plate voltage rises towards the supply value generating the leading edge of the trapezoidal sweep waveform. The cutting off of V1 acts like opening a switch, and causes capacitor C1 and resistor R2 to be brought into circuit action. An equivalent circuit with corresponding waveforms is shown in the accompanying illustration for ease of understanding. Capacitor C1 charges up to towards the value of the plate supply voltage through resistors R1 and R2 at a rate de-

pendent on the product of C1 times the sum of R1 and R2. The output is taken across capacitor C1 and resistor R2. Thus, as capacitor C1 charges, the voltage drop across R1 appears at the output. The output voltage increases toward the plate voltage supply at the charging rate of capacitor C1 until the end of the negative rectangular input pulse occurs. At this time, the positive trailing edge drives V1 into conduction, removing capacitor C1 and resistor R2 from the circuit action by effectively closing the triode switch shown in the illustration of the equivalent circuit of the sweep generator. The circuit remains in this state until the next negative rectangular pulse is applied to the input. The resultant output waveform is a trapezoidal pulse for every negative rectangular pulse applied to the input.

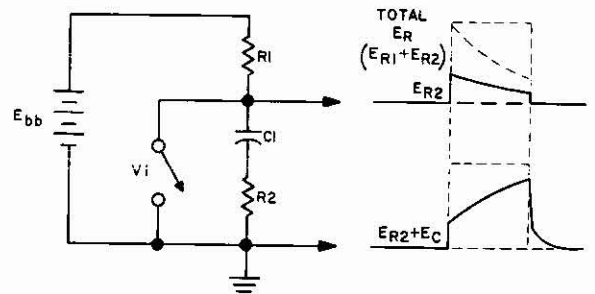

Equivalent Trapezoidal Sweep Generator Circuit

The trapezoidal pulse is applied to a sweep amplifier where it is amplified before being applied to the sweep coil circuit. A typical sweep amplifier is shown in the accompanying illustration. Capacitor C1 is a coupling capacitor and the grid of V1 is returned to ground through grid resistor R1. Cathode bias is provided by resistor R2 and R2 is bypassed by capacitor C2 to prevent any degenerative effect. Vacuum tube V1 is a beam power tube, used because of its high power sensitivity. Power amplification is required to provide sufficient current to the deflection coils. The coils may require from 50 to 100 milliamperes of current for maximum deflection. Inductance L1 and resistance R3 comprise the deflection coil and act as the plate load for the sweep amplifier. The output waveform, at the plate of V1, is trapezoidal. As this waveform is applied to the deflection coil, it becomes resolved to a sawtooth waveform across the resistance of the coil, and a square waveform across the inductance. The square wave across the inductance produces a sawtooth sweep current due to current lagging voltage in an inductance. (For detailed information on amplifier circuits refer to section 6, of this Handbook).

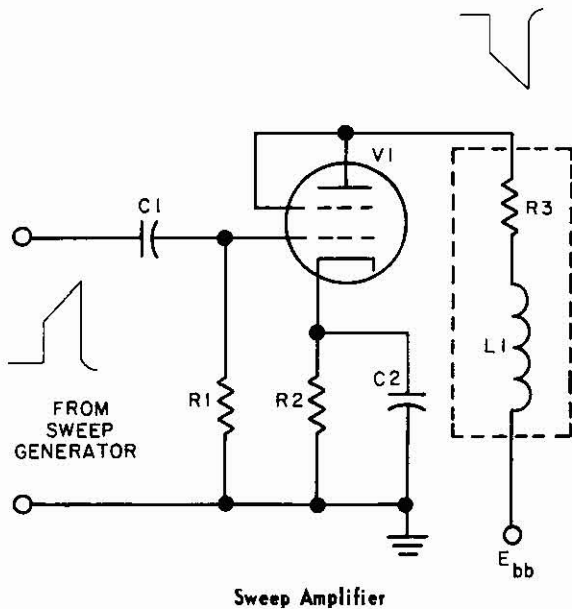

Sweep Amplifier

The PPI sweep starts at the center of the CRT, and moves radially outward to the periphery of the CRT. The sweep trace position is made to indicate target bearing (or azimuth) by rotating it in synchronization with antenna rotation. This can be accomplished by any of several methods in two general categories. The first category uses a mechanical azimuth sweep, which provides a means of physically rotating the deflection yoke in synchronization with the antenna. This may be accomplished by using synchronous motors connected to the same power supply which drives the antenna and the deflection yoke; or it may be accomplished by using electromechanical repeaters to provide proper synchronization. The accompanying figure illustrates how deflection is produced at the cathode ray tube.

The second method is to use an electrical azimuth sweep which uses a stationary deflection yoke. The amplitudes of the sawtooth sweep currents are varied sinusoidally, from zero to maximum, corresponding to the rotation of the antenna. Furthermore, there is a 90° phase difference between the amplitude variations of the horizontal and vertical sawtooth waveforms. The sinusoidal variation is such that at maximum amplitude of the vertical sawtooth signal, the sweep will extend from the center of the CRT to the top of the CRT, or the maximum vertical position, which usually represents north. The amplitude of the horizontal deflection sawtooth waveform is zero, at this time. Thus, the sweep does not extend in the horizontal direction at all. If the sweep were to represent East, or 90° east of the direction of travel, the horizontal

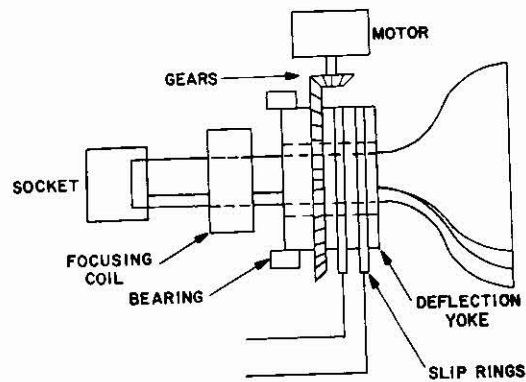

Mechanical Azimuth Sweep

deflection sawtooth amplitude would be maximum and the vertical deflection sawtooth amplitude would be minimum, or zero. Once the sweep travels beyond East, or 90° east of the direction of travel, the amplitude of the vertical sawtooth becomes negative; and, once the sweep travels beyond South, or 180° from the direction of travel, the horizontal sawtooth amplitude becomes negative also. The accompanying figure shows the deflection coil currents for electrical azimuth sweep.

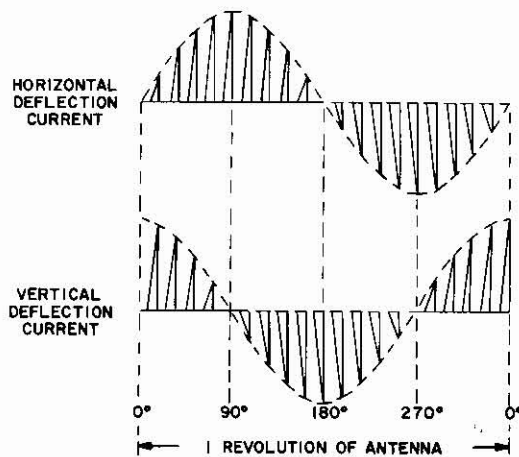

Deflection Coil Currents for Electrical Azimuth Sweep

In order to obtain two sinusoidally varying sawtooth waveforms, having a 90° phase difference, a rotary transformer is used. This transformer resembles a small electric motor and has two secondary windings, which are mounted

at right angles to each other in the stator housing. The primary is mounted on the rotor, which is driven by the rotating antenna. A trapezoidal-wave generator is connected to the primary winding by means of slip rings. As the rotor is turned, the voltage obtained from either secondary varies. Maximum voltage is obtained from one secondary when zero voltage is obtained from the other. The transformer is so constructed that the amplitude of the output voltage varies sinusoidally with the rotor angle. The amplitudes of the trapezoidal output voltages, then, vary sinusoidally, and are 90° apart in phase. The trapezoidal output voltages are applied to separate power amplifiers. The required sawtooth sweep currents are obtained at the output of the power amplifiers. Sweep clippers are usually used to keep the reference level constant, and cause every sweep to start at the same point on the CRT.

It was mentioned previously that the start-stop multivibrator has an output applied to the control grid of the CRT and to the marker generator, as well as to the sweep generator. A positive gate produced by the multivibrator is applied to the CRT control grid. This positive pulse increases the electron flow between the cathode and the face of the CRT, and permits the intensity of the trace to increase during the period that the timing pulse is applied. This is in reality an unblanking gate which permits the CRT to be operated at the desired time.

The negative rectangular pulse applied to the marker generator from the start-stop multivibrator is used to trigger the production of range marks on the screen of the CRT. These range marks provide a means of determining representative distances of targets from the origin. A typical range marker generator is shown in the accompanying illustration. It is comprised of four triodes, the first of which (V1) acts as a switch for triodes V2 and V3, which can only conduct when V1 is cutoff. Triodes V2 and V3 form a complete path for the series resonant circuit L1 C3, or L2 C4, which determines the frequency of the range mark pulses. Transformer T1 differentiates the output waveform of V3 before being applied to V4, which serves as a cathode follower output stage. Capacitor C1 is an input coupling capacitor, and resistor R1 establishes contact bias for V1. Resistor R2 is a plate voltage dropping resistor to provide V1 with a lower potential than the plate voltage value of V2. Resistor R4 is a common plate load resistor for triodes V1 and V2. Resistor R3 places the cathode of V1 at a less positive potential than the cathode of V2. Resistor R5 holds the grid of V2 at approximately zero bias. Resistor R6 serves as a return to ground for the grid of V2, and capacitor C2 places the grid of V2 at an a-c ground potential. Resistor R7 places the cathode of V2 at some less positive potential than the cathode of V3. Resistor R8 is part of a cathode bias voltage divider on the cathode of V3. The divider consists of R3, R7 and R8 which places different fixed bias on the cathodes of V1, V2, and V3 respectively. The primary of T1 serves as a plate load for triode V3. Capacitor C5 couples the differentiated waveform to the grid of the cathode follower, V4. Resistors R11 and R9 place the grid of V4 at some highly negative potential.

Resistor R10 provides a d-c return to ground for triode V4 and together with R11 forms a bias voltage divider between the negative supply and ground. Resistor R12 is the cathode resistor of V4 and serves to match the output of the cathode follower.

Prior to the application of the sweep starting pulse from the start-stop multivibrator, the triode V1 is conducting, which keeps the plate voltage at a low value. This low voltage prevents the plate voltage of V2 from being higher than the grid voltage of V2. This low plate voltage of V1 also causes the potential at the grid of V3 to be less positive than the cathode and of sufficient negative value to cutoff the tube. With V3 cutoff no output signal is developed.

When the negative sweep start pulse is applied to capacitor C1, triode V1 is cutoff, which causes the plate voltage of V1 to increase, and the voltage on the plate of V2 to increase, and at the same time causes the grid voltage of V3 to increase. With the increased grid voltage, V3 conducts completing the circuit containing triode V3, the series resonant circuit of L1 C3 or L2 C4, triode V2, and the primary of T1. A pulse type waveform is produced by this circuit with a frequency dependent on the value of the resonant circuit. The waveform is applied to transformer T-1, where it is differentiated by the inductance in conjunction with the resistance of the primary before being coupled to the secondary of T1. From the secondary of T1, the differentiated pulses are applied to the grid of cathode follower (V4) through capacitor C5, which blocks out any d-c component. The output is obtained from cathode resistor R12. This output is not only decreased in amplitude and in phase with the applied pulses, but it is also limited to positive pulses by the high negative bias on the grid of V1. These positive pulses are then applied to the control grid of the CRT to increase the intensity of the trace at the point where the range marker rings are to occur.

The video signal is applied to a biased video limiter, where the signal is made to vary above a specific level, so that the signal will not become so negative as to cause blooming on the screen. A schematic of the video limiter is shown in the accompanying illustration. The limiter consists of only three components; resistor R1, used to drop the applied voltage when diode V1, the second component, is conducting, and voltage source Ecc, the third component, used to establish the limiting level.

With no signal applied there will be no signal output. When a positive signal is applied, it will appear at the output unaffected by the limiting diode and the voltage source Ecc, since the nonconducting diode acts as an open circuit. Even as the signal begins going negative, the signal will remain unaffected; since the negative voltage on the plate of V1 is greater than the applied negative signal, thereby maintaining V1 in the nonconducting state. When the signal becomes as negative as Ecc, V1 begins conducting, and the output is now Ecc. Even when the input becomes more negative, the output still remains at the value of the source voltage Ecc. The output voltage will vary as the input signal only when the input signal

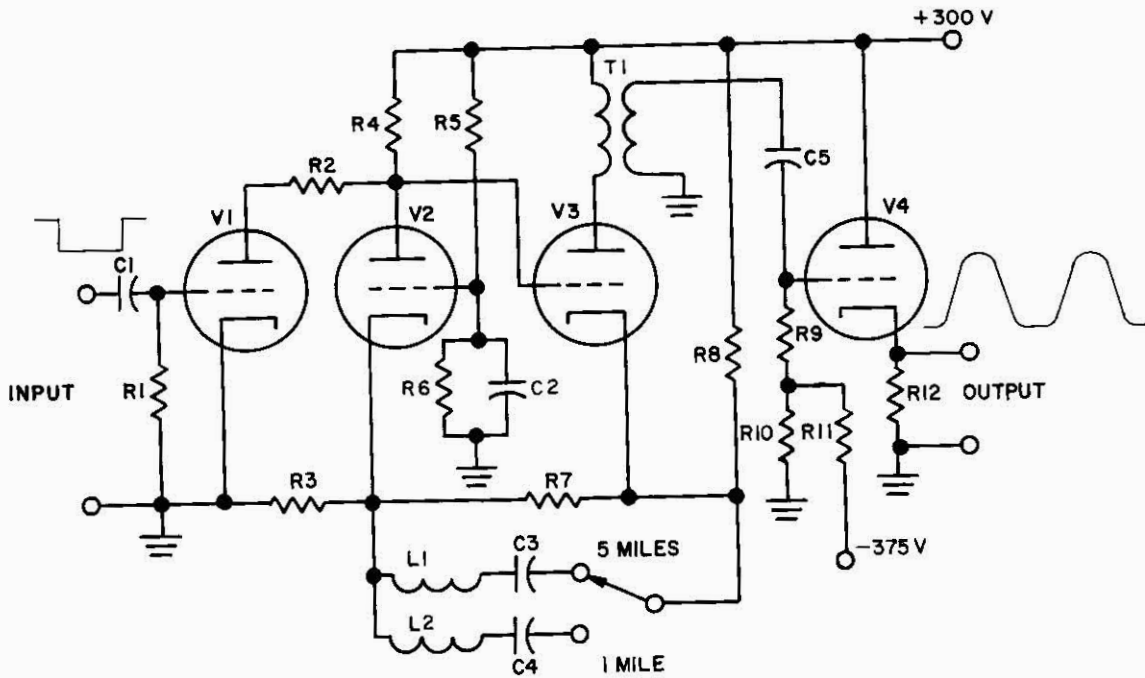

Range Marker Generator

resistor, and resistor R2 is the cathode bias resistor, which, along with R1, establishes the total grid bias. R2 is made variable to regulate the gain of the amplifier. Capacitor C2 is the cathode bypass capacitor, which bypasses the a-c signal to ground and prevents degeneration. R4 is the screen grid dropping resistor, and capacitor C1 is the screen grid bypass capacitor. The load consists of resistor R5, and resistor R6; however, at high frequencies the signal bypasses R6 through capacitor C4. Capacitor C5 is the coupling capacitor to the following stage.

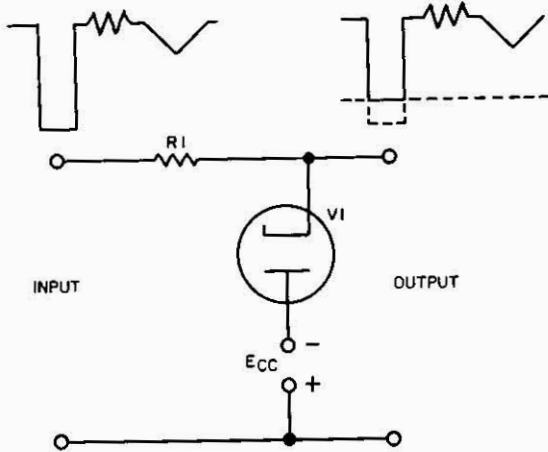

Video Limiter

becomes more positive than Ecc.

The output voltage of the video limiter is applied to a video amplifier, or several video amplifiers, where the voltage is increased in gain before being applied to the cathode of the CRT. A typical video amplifier is shown in the accompanying illustration. Resistor R1 is the grid leak

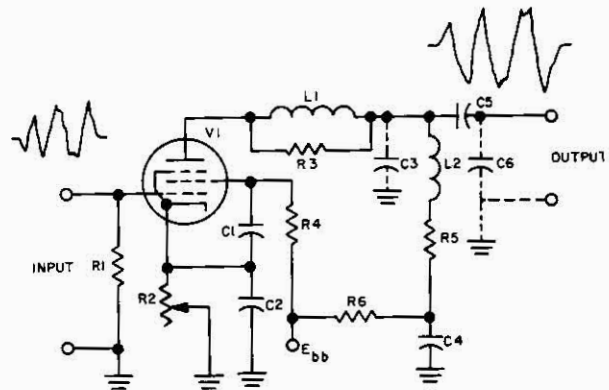

Video Amplifier

Up to this point, the components which were discussed could form a common amplifier. The remaining components add to the previously discussed components to form the video amplifier. Inductance L1 is a series peaking coil, which functions as a series filter for passing required frequencies. It also isolates circuits preceding it from circuits following it. Resistor R3 aids L1 by extending the effects of L1 and broadening the Q characteristics. Inductance L2 is a shunt peaking coil, which forms a parallel resonant circuit with the distributed capacitance (C3) and provides a high impedance for the signal. Capacitance C6 is the inter-electrode and distributed capacities of the following stage. Vacuum tube V1 is a pentode.

The negative signal coming from the video limiter is applied directly to the grid of the tube V1, decreasing the conduction of V1 and varying it in accordance with the signal variation, and at the same time establishing a bias level through resistors R1 and R2. The variation in conduction rate of V1 produces an oppositely varying plate output voltage, which is developed across resistors R5 and R6. The higher frequencies of the signal, which would normally be lost or distorted by distributed capacitance (C3) and the interelectrode capacity, are passed undistorted by means of the series peaking (L1) and shunt peaking coils (L2) inserted in the amplifier. These coils form resonant circuits with the effective capacities, permitting the higher frequency signals to be passed easily to the output and preventing these frequencies from being shunted to ground. (For a more detailed discussion of video amplifiers refer to section 6 of this handbook.) One or several video amplifiers may be used to provide the desired amplitude of output signal.

FAILURE ANALYSIS.

Start-Stop Multivibrator.

No Output. Since the start-stop multivibrator is responsible for producing synchronized sweep, range markers, and intensified trace during the time that information is to be presented, a defect in this circuit will affect each of these areas. If no output occurs it will be difficult to localize the trouble, since no spot will appear on the CRT. This effect can also be caused by the sweep generator or sweep amplifier having no output.

The no-output condition, in the start-stop multivibrator, may be due to lack of signal or lack of plate supply voltage. Check the signal with an oscilloscope at the input of the multivibrator. Check the plate supply voltage with a voltmeter. If the no-output condition exists and there is plate supply voltage, the condition may be due to a combination of faulty components. If resistors R3 and R4 were both open, or if triodes V1 and V2 were both defective, the no-output condition would occur. Measure the resistors on a ohmmeter. If the condition still exists, triodes V1 and V2 are probably defective.

Low or Distorted Output. If a low or distorted output occurs in the start-stop multivibrator, it becomes more apparent that the trouble is in this stage, rather than the sweep generator or the sweep amplifier, since each one of

the three applications of the multivibrator will show the effect of the trouble.

The low or distorted output may be due to any of the following component failures: Shorted or open plate load resistor R3, shorted or open plate load resistor R4, shorted or open bias resistor R1, shorted or open bias resistor R2, shorted or open capacitors C1 or C2, improper plate supply voltage, defective triode V1, defective triode V2, or improper input signal.

To determine which of these component failures is responsible for the condition, make the following checks: measure the input signal with an oscilloscope; measure the plate supply voltage with a voltmeter, and adjust the supply for the proper voltage; measure the resistors with an ohmmeter to be certain that they are of the proper ohmic value and within tolerance; and measure the capacitors with an in-circuit capacitor checker. If these components have been checked and the condition still exists, triodes V1 and V2 are probably at fault.

Trapezoidal Sweep Generator.

No Output. If no output is obtained at the output terminals of the sweep generator, no sweep is produced and the cathode ray tube will indicate only a single spot at the origin of the sweep.

A no-output condition may be due to any of the following circuit failures: no plate supply voltage, open resistor R1, open capacitor C1, or open resistor R2. To determine which of these is responsible for the no-output condition, first check the input signal with an oscilloscope. Check the plate supply voltage with a voltmeter, and adjust the supply voltage to the proper voltage value. Check resistors R1 and R2 with an ohmmeter, and check capacitor C1 with an in-circuit capacitor checker.

Low or Distorted Output. If a low or distorted output is obtained at the output terminals of the sweep generator, and the proper input signal is applied, the fault may be due to any of the same component failures that occur in the no-output condition, plus the possibility of a defective triode, V1. The same checks apply in the low or distorted output condition as in the no-output condition. If these checks do not locate the trouble, triode V1 is probably defective.

Sweep Amplifier.

No Output. If no output is obtained at the output terminals of the sweep amplifier, no deflection will be produced and the trace will be in the form of a single dot at the origin of the sweep.

A no-output condition may be due to any of the following circuit failures: open capacitor C1, no plate supply voltage, no input signal, or a defective triode, V1.

To determine which of these failures is responsible for the no-output condition, use the following checks: measure the input signal with an oscilloscope; measure the plate supply voltage with a voltmeter, and adjust the source if it is the cause of the condition; measure capacitor C1 with an in-circuit capacitor checker. If these checks do not locate the trouble, triode V1 is probably defective.

Low or Distorted Output. A low or distorted output may be due to any of the following circuit failures: shorted capacitor C1, shorted or open resistor R1, shorted or open resistor R2, a shorted or open capacitor C2, low plate supply voltage, or a defective triode, V1.

To determine which of the circuit elements is responsible for this condition, make the following checks: measure capacitors C1 and C2 with an in-circuit capacitor checker; measure the values of resistors R1 and R2 on an ohmmeter; measure the plate supply voltage source with a voltmeter, and adjust the source to the proper plate supply voltage. If these checks do not lead to the defective part, triode V1 is probably defective.

Range Marker Generator.

No Output. A no-output condition in the range marker generator will result in no range markers being produced on the face of the CRT. This condition may be due to any of the following circuit failures; no plate supply voltage, defective triode V2, defective triode V3, open or shorted transformer T1, open inductors L1 or L2, open capacitors C2 or C4, open capacitor C5, open or shorted resistor R12, or defective triode V4.

To determine which of these components is at fault, make the following checks: measure for possible defective resistors with an ohmmeter; check the applicable capacitors with an in-circuit capacitor checker; check the ohmic values of inductors L1, L2, and the primary and secondary windings of transformer T1. Check the plate supply voltage with a voltmeter, and adjust the plate supply voltage if it is not the proper voltage. If the no-output condition still exists after all other checks have been made, triodes V2, V3, and V4, and probably defective.

Low or Distorted Output. Low or distorted output may result in improperly situated range marks on the screen of the CRT. This condition may be due to any of the following circuit failures, providing the proper input signal is applied: improper plate supply voltage, shorted capacitor C1, shorted capacitor C2, shorted capacitors C3 or C4, shorted capacitor C5, shorted inductors L1 or L2, shorted or open transformer T1, shorted or open resistors R1, R2, R3, R4, R5, R6, R7, R8, R9, R10, or R11; or defective triodes V1, V2, V3, or V4.

To determine which of the components is responsible for the condition, make the following checks: check the applicable capacitors with an in-circuit capacitor checker; check applicable resistors with an ohmmeter; check inductors and transformer windings with an ohmmeter; Check the plate supply voltage with a voltmeter, and adjust the supply if the voltage is not the correct value. If the low or distorted output still exists after checking and correcting any of the possible foregoing failures, the tubes are probably at fault.

Video Limiter.

Since the video limiter is composed of three components the failure analysis may be simplified.

No Output. In order to have a no-output condition, an open resistor R1, an open bias supply voltage E_{cc}, or a defective diode V1 would have to exist. This no-output

condition would result in no indication of the target as well as no indication of the area being scanned.

To determine which of the three components is responsible for the no-output condition, measure the bias supply voltage with a voltmeter and adjust it if it is not the correct value; measure resistor R1 and check V1.

Low or Distorted Output. A low or distorted output would result if any one of the same three components is defective. Use the same checks to determine which of the components is responsible for the low or distorted output condition.

Video Amplifier.

No Output. A no-output condition in the video amplifier would result in no visual representation of the target or scanned area. This condition may be due to absence of signal, absence of plate supply voltage, open resistor R6, open resistor R5, open inductor L2, shorted capacitor C4, open capacitor C5, or a defective pentode V1.

To determine which of these components is defective make the following checks: measure the input signal with an oscilloscope; check the plate supply voltage source with a voltmeter and adjust the source to the proper value, if it is not the proper voltage, check resistors R5 and R6 with an ohmmeter; check inductor L2 with an ohmmeter, and check capacitors C5 and C4 with an in-circuit capacitor checker. If the no-output condition still exists after these checks and corrections have been made, pentode V1 is probably at fault.

Low or Distorted Output. A low or distorted output may be caused by any one of the actual circuit components being defective, or an improper input signal.

To determine which component is at fault, use the following procedures: check the input signal with an oscilloscope, check the plate voltage supply with a voltmeter and adjust the supply voltage to the correct value, if it is not at the correct value. Check all resistors with an ohmmeter and check the ohmic values of inductors L1 and L2 with an ohmmeter. Check capacitors with an in-circuit capacitor checker. If all of these checks do not locate the defective component, pentode V1 is probably at fault.

OTHER TYPES OF ELECTROMAGNETIC SCANS.

APPLICATION.

Of the remaining types of electromagnetic scans three general types are probably encountered more often than any others. These scans are the spiral, the RHI, and TV scans. The spiral scan is usually used for range measurements where it provides a much longer time base than is available for circular or linear scans. The RHI scan is used where it is desired to determine the range and target height as a special radar presentation, and the television (TV) scan is used to reproduce scenes or images.

CHARACTERISTICS.

A long persistence type of CRT is used with the RHI and spiral scans, while a medium persistence CRT is used with the TV scan to prevent blurring of the moving images.

In the RHI scan the horizontal base line always indicates range, while the height is indicated vertically.

The spiral scan may start at the center of the CRT and rotate spirally outward, or start at the periphery of the tube and rotate spirally inward to the center, depending upon design.

The TV scan uses a two field, odd-line interlaced scan operating at 30 frames vertically per second, and 525 lines horizontally, (a sweep frequency of 15750 Hz).

Scanning begins at top left of the CRT and travels to the right and down.

Each frame consists of 525 individual horizontal scanning lines which move from top to bottom.

CIRCUIT ANALYSIS.

General. The spiral scan, the RHI scan, and the TV scan are all produced by means of an electromagnetic deflection system; however, each may be produced by an electrostatic deflection system for special applications. The spiral and the RHI scans are similar in circuitry and in operation to previously mentioned CRT scans. The TV scan is unique in comparison to these scans, since, this type of scan produces a detailed reproduction of a specific scene or image.

An RHI scan is similar to an off-center PPI scan, but has an elevation or height indication in place of what would normally be the azimuth or bearing indication, as shown in the accompanying illustration.

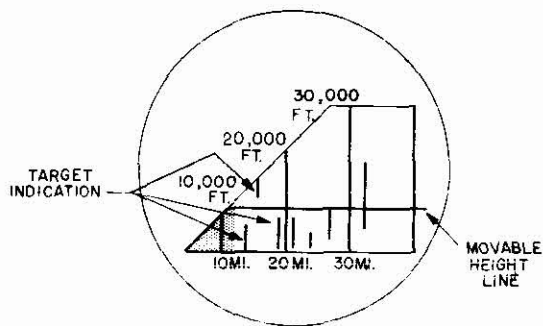

Range Height Indicator Scan

The actual representation of the trace on the CRT originates at the lower left side of the screen and extends horizontally to the right, and vertically at the same time, resulting in an angular type display. The horizontal distance represents the range and the vertical distance represents the height. The origin of the trace represents the

radar location. There are equidistant vertical lines along the angle of the display, which are range markers. A movable horizontal line appearing across the pattern is used to determine the height of the target. Targets appear as intensified portions of the trace on the CRT.

The spiral scan is used when linear and circular traces do not have a sufficiently long time bases to record certain data with the required accuracy. The spiral scan is evolved from the circular scan, as used in PPI and is shown in the accompanying illustration.

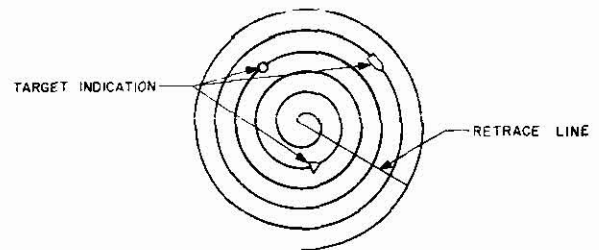

Spiral Scan

The range of the scan can be varied by changing the number of turns in the spiral. The sweep rotates at a constant rate of speed, so that equal divisions along the spiral indicate equal range increments. The spiral scan may start at the center of the trace, as it does in PPI, but it rotates spirally from the center of the CRT and only reaches the periphery of the tube by the end of the sweep. It is possible, too, that the spiral scan may start at the periphery of the tube and rotate spirally toward the center of the CRT, only reaching the center of the CRT by the end of the trace. The origin of the sweep represents the position of the radar location. Targets are represented by intensified portions of the trace.

The TV, or uniform linear scan, is based on a beam that moves much as the human eye does in scanning a written page. It moves from the top left to the right and rapidly returns to the left, only slightly further down from the top than the previous line. It moves this way until it reaches the bottom of the sweep on the right side. This, however, only constitutes half of a complete frame. To complete the second half frame the sweep is rapidly returned to the top center of the CRT. The first line in the second half frame descends less than the first line in the first half frame, since the second half frame starts at the top center and has less horizontal distance to cover, and less time for the line to descend than the first half frame. In this way, the second half frame fills in scanning lines between the lines that were scanned during the first half frame.

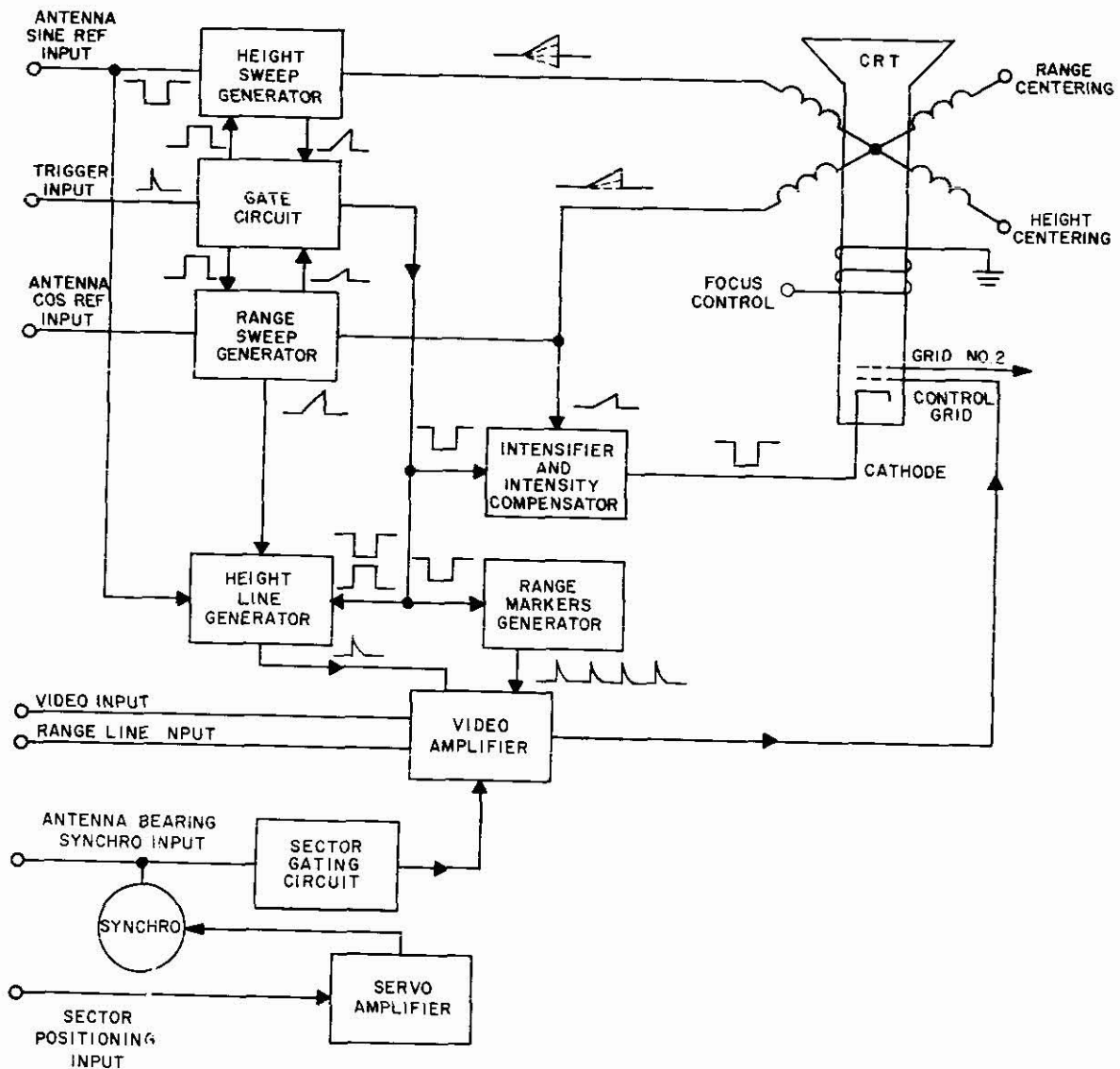

RHI Block Diagram

range, pulse repetition rate, and the elevation angle. Intensity compensation is produced by automatic variation of the d-c voltage on the cathode of the CRT.

The range marker generator circuit produces equally spaced range markers. The range markers are applied to a video amplifier where they are amplified, and then applied to the grid of the CRT. The nodding of the antenna causes the markers to appear as bright lines on the sweep.

The video amplifier stage amplifies the video target signals received from the radar receiver. It also amplifies the range markers, the height line pulses, and the range

line input signals, and mixes them with the video signal. The amplified signals are applied to the CRT control grid.

The sector gating circuit, which has its output connected to the video amplifier stage, allows only those targets present in a selected azimuth sector to appear on the CRT face. It also determines the angular width of the sector to be viewed.

The servo amplifier stage supplies voltage to a motor which drives a sector gating synchro rotor. The position of the synchro rotor determines the bearing of the azimuth sector viewed on the RHI scope. The position of the sector

gating synchro rotor always corresponds with the setting of the manual sector control.

The resulting RHI sweep appears on the CRT as a wedge. The vertex of the wedge, corresponding to the origin of the trace, appears at the left lower portion of the screen. The horizontal distance of the trace corresponds to the range, and the vertical distance of the trace corresponds to the height or elevation of the trace. The range indicating marks are vertical lines, of intensified trace with angular compensation, equidistant along a horizontal plane. The height line is a horizontal line of intensified trace. The video information coming from the radar receiver, which represents targets within the selected sector, produces intensified portions of the trace at the range and height positions on the display corresponding to the actual location of the target from the radar location.

Spiral Scan Circuit Operation. A typical block diagram of the spiral scan producing system is shown in the following illustration. Since the operation of each basic circuit is described in detail in other sections of this Handbook, circuit operation will be limited to the effect of each stage on the total system.

The primary controlling state is the start-stop multivibrator. It converts an external negative timing pulse into a number of square wave pulse to the sweep generator stage, results in a trapezoidal sweep pulse output with the same duration as the square wave pulse applied to the input of this circuit, and occurring at the same frequency and time as the input pulse. This trapezoidal sweep output is applied to the sweep amplifier stage.

The application of the negative square wave pulse, from the start-stop multivibrator stage, to the trapezoidal generator stage also results in a trapezoidal output. This trapezoidal output, unlike that of the sweep generator stage, is not of the same duration as the input pulse, but occurs for a longer period of time. This period of time normally is an even multiple of the input pulse. The ratio of the trapezoidal pulse to the negative square input pulse determines the number of turns in the spiral sweep on the CRT. The trapezoidal output pulse, like the output of the sweep generator stage, is also applied to the sweep amplifier stage.

The negative square wave pulse output from the start-stop multivibrator stage is also applied to the markers generator stage, where short duration marker pulses are produced for application to the CRT control grid. These pulses produce intensified points on the sweep trace which correspond to specific range indications.

The positive square wave pulse produced by the start-stop multivibrator stage is applied to the control grid of the CRT. This pulse provides unblanking of the sweep on the CRT during the period that it is applied.

The trapezoidal sweep pulses produced by the sweep generator stage and the varying amplitude trapezoidal pulse from the trapezoidal generator stage are combined in the sweep amplifier stage and amplified. The addition of the increasing trapezoidal pulse to the sweep pulses produces a continually increasing sawtooth sweep of current through the deflection coils while the yoke rotates.

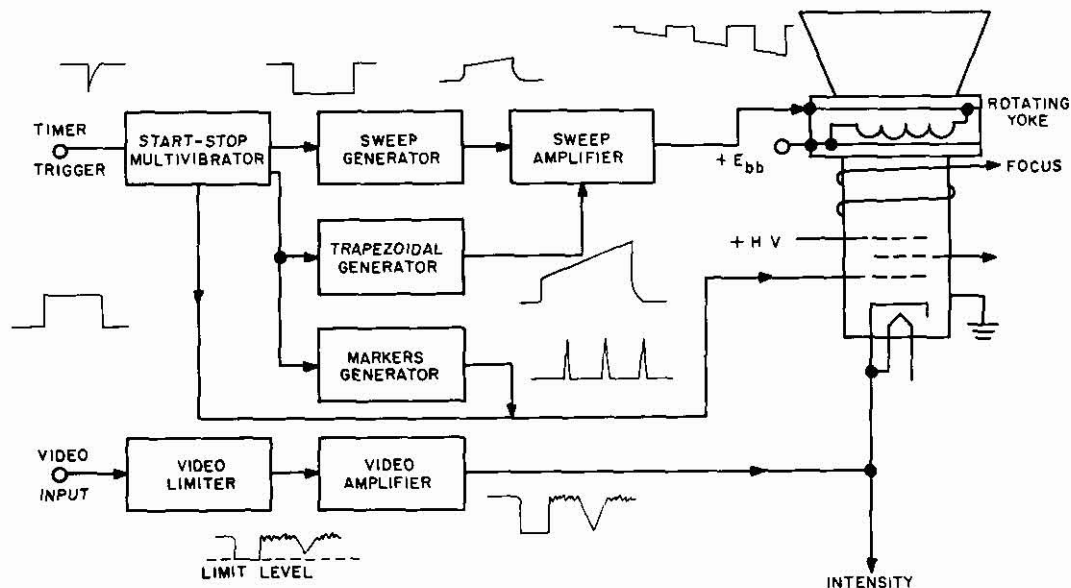

Spiral Scan System Block Diagram

The resulting sweep on the CRT is similar to that of the PPI sweep, with the exception that each pulse produced by the sweep generator stage does not produce a scanning line which extends from the center of the sweep to the periphery of the CRT. Instead, each sweep line extends a distance from the center of the CRT which corresponds to the amount of sawtooth current occurring in the deflection coil, at that time. Since the current in the deflection yoke continually increases in a sawtooth manner, the distance that the sweep trace extends from the center of the sweep increases in a linear manner, while rotating about the sweep origin, until it reaches the periphery of the CRT, forming a spiral sweep.

The video input is applied to a video limiter stage where any portions of the signal extending beyond the limiting voltage level are clipped off. The limited signal is applied to a video amplifier stage. The video amplifier stage amplifies the limited video signal. This amplified and limited video signal is then applied to cathode of the CRT, where it causes the intensity of the electron beam to vary accordingly.

The resultant scan on the CRT appears as a spiral, with the sweep originating at the center of the CRT and gradually reaching the periphery of the CRT by the end of the spiral, which may contain a number of turns. Equidistant intensified points on the spiral sweep correspond to range indication marks. Any other intensified points or sections of the spiral, or extra-intensified range marks correspond to target indications.

Television Scan Circuit Operation. The typical block diagram of a television scanning system is shown in the accompanying illustration, the scanning system comprises approximately one third of the complete television receiver. The synch (pulse) separate stage, which contains a limiter, an integrator and a differentiator is not actually part of the scanning system of the receiver, but is included in the block diagram to give a more complete description of the development of vertical and horizontal sweep pulses.

Actually the integrator and differentiator stage consists of only a resistor and capacitor combination. The clipper circuit eliminates all portions of the composite video signal below the synch pulse level. The differentiator network segregates the horizontal pulse information from the combined horizontal and vertical pulse waveform, and applies the integrated waveform to the vertical sweep stage.

The differentiator waveform is used by the afc circuit to maintain the horizontal oscillator output in phase with the synchronizing pulses.

The frequency stabilized horizontal synchronizing pulses are applied to a free-running multivibrator to develop a sawtooth output waveform. This multivibrator, the horizontal oscillator, operates at a frequency which is slightly lower than the synchronizing pulse frequency. The synchronizing pulses, then, trigger the multivibrator into action at the synchronizing pulse frequency.

A portion of the output of the horizontal oscillator is fed back to the afc circuit to stabilize the horizontal frequency, and the stabilized output is applied to a sweep

amplifier, where it is amplified and coupled to the horizontal deflection coil through a transformer. A sawtooth current is developed in the horizontal deflection coil which electromagnetically sweeps the CRT electron beam horizontally. The horizontal output transformer is also used to furnish the high voltage for the CRT anode, and a damping circuit is connected across the deflection coil and output transformer secondary to prevent continuous shock oscillations from occurring in the horizontal deflection coil during the retrace time of the sweep. The damper circuit is also used to furnish an additional d-c boost voltage for the horizontal oscillator as shown in the block diagram.

The integrated portion of the synchronized pulse waveform, when applied to the vertical oscillator, triggers the vertical oscillator stage and a free-running multivibrator when the value of the integrated waveform reaches a certain amplitude. The integrated vertical waveform reaches this triggering level at a specific, regular rate, which is much slower than the differentiated pulse rate. The output of the vertical oscillator, is also a sawtooth type waveform occurring at the triggering level rate of the integrated waveform.

The output of the vertical oscillator is applied to the sweep amplifier stage of the vertical sweep network. Here the vertical sweep waveform is amplified and coupled to the vertical deflection coils, causing a sawtooth current to be developed, which electromagnetically deflects the electron beam of the CRT in a vertical direction.

The resultant scan on the CRT is one in which the horizontal sweep occurs at a frequency of 15,750 Hz which is approximately 5000 times that of the vertical frequency. A total of 262.5 horizontal lines is swept by the time the horizontal scan has completed one top to bottom (vertical) sweep on the CRT. This vertical sweep occurs 60 times a second, however, this only constitutes half of a complete picture frame. During the next vertical sweep an additional 262.5 horizontal lines are scanned from top to bottom of the CRT at the same rate of 60 times a second. These lines interlace between those which were scanned during the first half frame. A total of 525 horizontal scanning lines are used to provide greater detail in the picture. The reason for scanning only 262.5 horizontal lines for only one vertical sweep rather than scanning the full 525 lines for one vertical sweep, is that if the 525 lines were scanned at one time the complete picture would only be repeated 30 times a second and cause the display to flicker.

The TV scan moves much as human eyes do in scanning a written page. The scan starts at the top left hand side of the CRT screen and proceeds horizontally to the right with a very slight downward movement at the same time. The scan is rapidly returned to the left side. After completing the first horizontal scanning line the CRT is blanked out so that it is incapable of producing a visible line during this retrace period. Upon being returned to the left side of the CRT, the next scan line is displaced slightly further down than the starting point of the first scanning line and the CRT is unblanked for the next line. Two

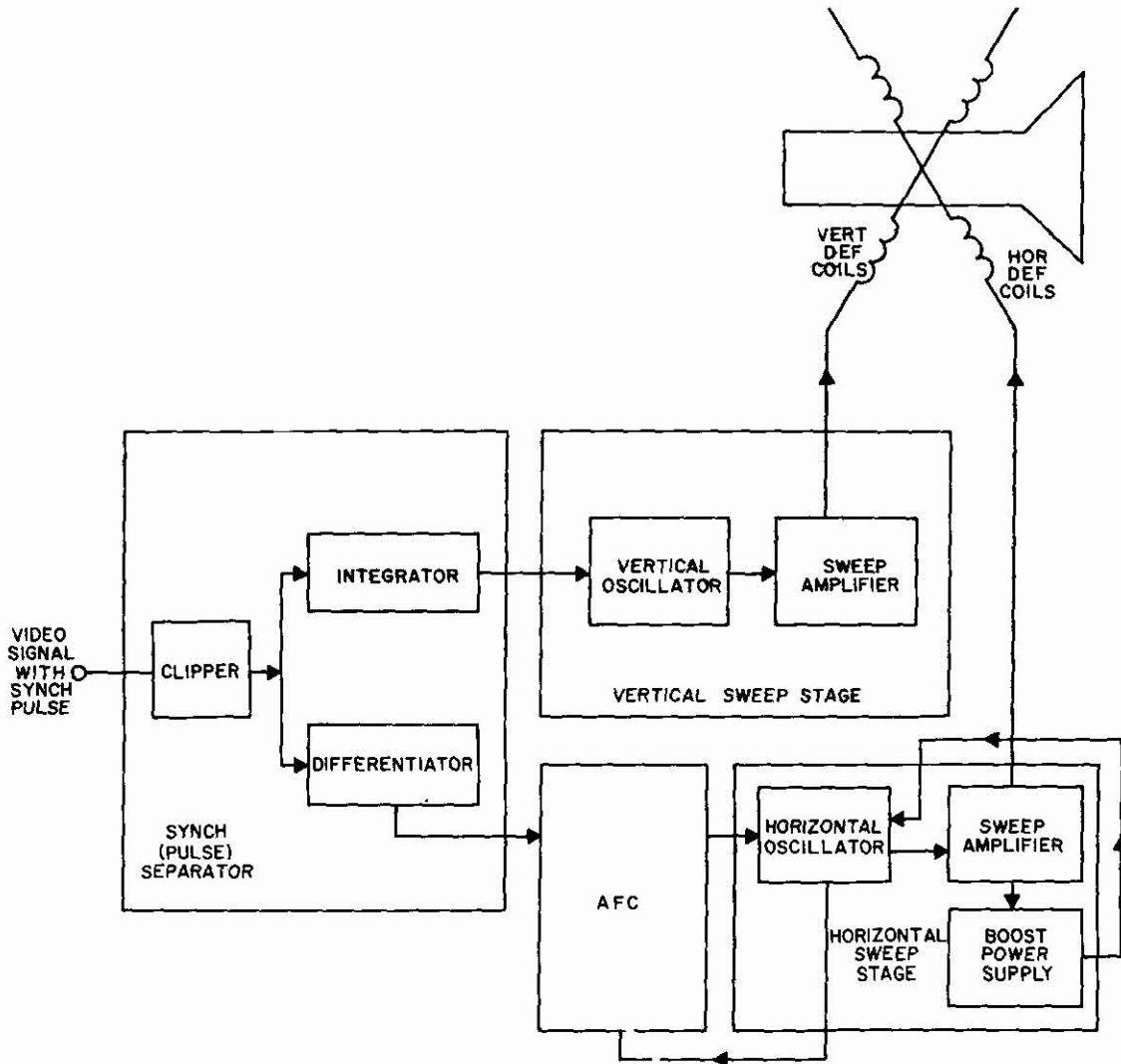

TV Scanning System

hundred sixty two and one half lines are scanned in this manner, until the scan reaches the bottom center of the CRT. Upon reaching this point, the scan again is blanked out during the vertical retrace and is rapidly brought back to the top center of the CRT. The same scanning procedure as described for the first half-frame occurs for the second half-frame, only this time the scanning lines are interlaced between those scanned during the first half-frame. The result is that a complete picture appears on the CRT screen 30 times a second, with half of this picture changing 60 times a second to eliminate flicker.

FAILURE ANALYSIS.

RHI Scan. In order for a no-output condition to exist, which is characterized by no indication of any kind on the CRT, a faulty power supply or a failure in each of the circuits comprising the system would have to occur. It is highly unlikely that every circuit in the system would fail, so the no-output condition would normally be limited to power supply failure. Check the power supply with a voltmeter to determine if the supply or a fuse is at fault.

There are several types of low or distorted outputs associated with the RHI system. By looking at the trace on the RHI indicator it is usually possible to determine the probable location of the failing circuit.

If there is no indication on the CRT, it is not necessarily true that a no-output condition exists. It only means that either improper potentials are being applied to the CRT electrodes, the unblanking circuit is defective, or that the CRT, itself, is defective. First determine if the proper voltages and unblanking waveforms exist on the electrodes of the CRT, the deflection coils, and the centering control with a high resistance voltmeter, and an oscilloscope. If the proper voltages and waveforms are present, the fault is in the CRT. If the proper voltages and waveforms do not exist, proceed from the electrode showing voltage or waveform back towards the preceding stage to locate the defective component.

If, for example, the improper signal exists on the cathode of the CRT, the trouble may be in the intensifier and intensity compensation circuit stage, or in the gate circuit stage, or the sweep circuit stage. If the input of the intensifier or intensity compensation circuit stage is correct but the output is not, the trouble should be located within this circuit.

If improper input voltage to the intensifier and intensity compensation circuit stage exists the trouble precedes this stage. If the gate circuit stage input is faulty, the intensity of the trace is not synchronized with the range sweep. If it is the gate circuit stage itself that is faulty there will be no range or height sweep. If the trigger amplifier and the gate multivibrator of this stage are functioning properly there should at least be height and range sweep. The trouble may then be in the count-down multivibrator of this stage.

If the range sweep generator stage is defective not only is the intensity of the sweep affected, but the range indication is also incorrect. If this condition is indicated by the trace on the CRT, check the input of the range sweep generator stage with oscilloscope to determine if the antenna cosine reference input is incorrect and if this is correct, check the parts within the stage.

If the correct potential appears on the CRT cathode, but not on the control grid, the video amplifier stage or the preceding stages may be at fault. Check the several inputs of the video amplifier with an oscilloscope. If all the inputs are found to be correct, but the output is faulty the trouble must be in the video amplifier stage. If the video amplifier stage circuits are not faulty the preceding stages must be the cause of the trouble. The presentation on the CRT usually indicates which preceding stage is the cause of the specific fault in the CRT trace. If it is the video signal, itself, that is improper the trouble exists somewhere in the radar receiver, rather than in the RHI. If the trouble is in the sector gating stage the CRT presentation will indicate improper sector angle or improper selection of azimuth. If this indication is apparent check for the proper antenna bearing synchro input with an oscilloscope. If the sector positioning input signal is not apparent at the sector gating stage input the preceding synchro or the servo amplifier stage may be at fault. If the synchro is functioning correctly check the servo amplifier.

If the CRT presentation indicates that there is no height line available, the failure is either in the height line generator stage, the range sweep generator stage, the gate circuit stage, or the antenna sine reference input. If any of these stages, other than the height line generator stage, are faulty, other CRT presentation failures will also be indicated. If, however, it is the height line generator stage, only the height line will be missing from the CRT presentation.

If the CRT presentation indicates that there are no range marks, the trouble must exist in the range mark generator since any faulty stages preceding the range marker generator stage would affect the presentation in some other way.

If there is no indication of height (or vertical direction) on the presentation of the CRT, the failure is in either the antenna sine reference input or the height sweep generator stage. If the antenna sine reference input is proper and present, the trouble must be in the height sweep generator stage.

Spiral Scan. Failure of the CRT high voltage supply or loss of the unblanking pulse would cause the indicator to be blank and produce a no-output condition. Check the CRT anode voltage with a voltmeter, and check the start-stop multivibrator for a positive unblanking pulse using an oscilloscope. Usually observation of the indicator will indicate the stage or stages which might be faulty. For example, if there are no range marks visible on the spiral trace and the display otherwise appears normal, the marker generator is most likely at fault. Check the output of the marker stage with an oscilloscope and, if no markers appear when an input pulse is applied, the marker generator is defective. Likewise, if range markers appear on the trace but no targets appear, there is probably no video signal applied to the cathode of the CRT. Check the cathode voltage on the CRT with a voltmeter and use an oscilloscope to check the video limiter input and the video amplifier output. If no video appears at the output with video applied to the input, either the amplifier or limiter stages are at fault. Check the video limiter output to determine if it is at fault. If there is either no video input, or improper video input at the limiter it is obvious that the trouble is not in the scanning system but somewhere in the radar receiving system.

If there is no sweep apparent on the CRT but a bright spot exists at the center of the CRT, check for proper grid and cathode voltage with a voltmeter. If normal, either the sweep amplifier, sweep generator, or trapezoidal generator may be at fault. Check the output of the sweep amplifier with an oscilloscope and both inputs. If the inputs are normal but the output is improper the amplifier is at fault. If either input is improper the stage supplying the improper output is faulty. Also check the input to the presumed faulty stage to make certain the proper input gate is applied. If normal sweep outputs are obtained, either the CRT is defective or the deflection yoke is open or shorted. Check the resistance of the yoke coils with an ohmmeter.

TV Scan. Failure of the CRT high voltage supply, the d-c boost supply or a defective picture tube will usually produce a complete no-output condition with a blank CRT. Use a high resistance voltmeter and high voltage probe to check the high voltage, being careful to observe full safety precautions to avoid the possibility of dangerous shock. If the d-c boost voltage is normal check the electrode voltages of the CRT. Failure of the d-c boost supply can be caused by a shorted filter capacitor, a defective damper tube or circuit. Check the filter capacitor for a short with an ohmmeter and for proper value with an in-circuit capacitance checker. If the boost voltage is low, the damper tube is bad. Usually failure of the damper circuit involving sweep components, such as a shorted output transformer or defective deflection yoke will also cause loss of sweep, and no raster will appear on the CRT screen. Check the coils for the proper resistance with an ohmmeter. Usually defects in the sweep will be found in the section at fault. If the horizontal sweep is faulty check the horizontal sweep stages from input to output with an oscilloscope the point at which the waveform disappears or is distorted will usually indicate the circuit at fault. Likewise, for a faulty vertical sweep check the vertical sweep stages for input and output waveforms in a similar manner.

For example, if there is no vertical deflection, or a vertically rolling picture, or some other apparent trouble in the vertical scanning on the CRT, and the electrode and coil potentials have been checked, the trouble must exist in the vertical sweep stage or the integrator or clipper sections of the synch (pulse) separator. First check the input waveform of the vertical sweep amplifier with an oscilloscope. If the proper waveform is present but improper output exists, the trouble must be in this stage. If an improper input waveform is present check the input of the vertical oscillator with an oscilloscope. If the input waveform is proper, but the output waveform is improper, the trouble is within the vertical oscillator stage. If the input to the vertical oscillator is improper the trouble exists in the integrator or clipper sections of the synch (pulse) separator stage or in prior receiver stages. Also be certain to check that the vertical synch pulses appear in the input signal to the receiver.

If the picture on the CRT is horizontally rolling or if there are some other apparent horizontal scanning troubles, and the electrode and coil potentials have been checked and found correct, the trouble must exist in the horizontal sweep stage, the afc stage, or the differentiator or clipper sections of the synch (pulse) separator stage. First check the input of the horizontal sweep amplifier with an oscilloscope. If the input waveform is proper, but the output is improper, the trouble exists within the horizontal sweep amplifier. If the input of the sweep amplifier is improper check the input waveform of the horizontal oscillator. If the oscillator input is proper, the trouble is in the horizontal oscillator. If the oscillator input is improper check the inputs of the afc stage. If these inputs are correct, but the output pulse is incorrect, the trouble exists in this stage. If the input from the synch (pulse) separator stage is proper, but

the input feeding back from the horizontal oscillator is improper, the trouble is in the feedback circuitry from the horizontal oscillator to the afc stage. If the feedback input is proper, but the input from the synch (pulse) separator stage is incorrect the trouble must exist in the differentiator or clipper of the synch (pulse) separator, or in preceding receiver stage, or in the horizontal synch pulse contained in the input signal to the receiver.

BLANKING CIRCUITS.

APPLICATION.

Blanking is used in TV, radar, synchrosopes, and oscilloscopes to reduce the beam intensity and render invisible the retrace portion of the electron beam which produces the visible trace on the CRT.

CHARACTERISTICS.

Blanking is dependent on the sweep signal.

Blanking reduces the intensity of the electron beam of the CRT.

Blanking is accomplished by application of negative voltage to the control grid.

Blanking circuit is a resistor-capacitor combination.

CIRCUIT ANALYSIS.

General. Blanking circuits are used in CRT displays to prevent any indication of the retrace line from appearing with the display. This is accomplished by applying the sweep signal to an RC differentiating circuit, which develops a rectangular type waveform during the sweep discharge period. The rectangular (blanking) waveform is applied to either the control grid or the cathode of the CRT, depending on the polarity of the waveform. The rectangular waveform is usually connected in series with the CRT bias so that it increases the CRT bias and causes the electron beam to be cut off during the retrace time of the sweep, but has no effect on the beam during the active portion of the trace time of the sweep.

Circuit Operation. A typical RC blanking circuit is shown in the accompanying illustration.

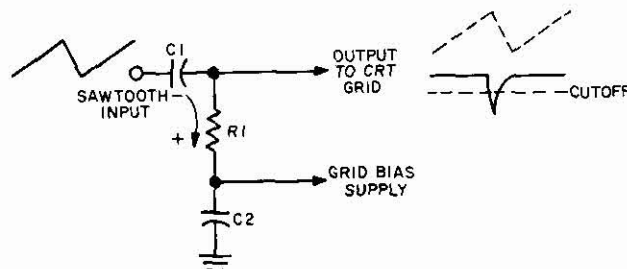

Blanking Circuit

Capacitor C1 and resistor R1 form a differentiating circuit. Capacitor C2 is a large a-c bypass capacitor which effectively places the lower end of R1 at ground potential. The sawtooth sweep voltage is applied to C1 and the charging current is relatively constant with the linear increase of the sweep voltage. Thus, the current flowing through R1 remains at a relatively constant and low value for the duration of the sweep trace. The voltage drop across R1, likewise, remains at a small but constant value for the linear rise of the sawtooth sweep. This small positive voltage drop is small enough, however, so that it has little effect on the grid bias which it opposes. The intensity of the electron beam is, then, relatively unaffected.

When the sawtooth sweep voltage quickly retraces, however, the discharge current change is great and rapid. As C1 discharges the high discharge current through R1 produces a large voltage drop across R1 which is opposite in polarity to the drop produced across R1 during the sweep. This retrace voltage series aids the normal negative grid bias applied to the control grid of the CRT. Hence, the bias voltage applied to the control grid of the CRT is now a large enough negative value to cut off the electron beam of the CRT, causing the CRT trace to disappear. The electron beam remains cut off during the entire retrace period, and for a short portion of the beginning of the trace period. Greater linearity of the sweep voltage and shorter retrace time of the sweep voltage causes the cutoff of the electron beam to extend less into the trace period.

A similar circuit may be used with a negative sawtooth applied to the input capacitor provided that the voltage across the resistor is applied to the cathode of the CRT. In this case a positive increase in bias is produced across R1, effectively driving the grid more negative and producing the same biasing-off of the beam.

FAILURE ANALYSIS.

No Output. If capacitor C1 were open none of the sweep voltage would be applied to the differentiating circuit and thus no voltage would be produced across R1. In this case, only the normal grid bias would be applied to the control grid of the CRT and blanking would not occur. To determine if C1 is defective, check it with an in-circuit capacitor checker. If resistor R1 were open, not only would no voltage drop across it, but no grid bias would be applied to the CRT and the screen would be brightly illuminated. To determine if R1 is open, check the resistance with an ohmmeter. If capacitor C2 were open there would be no ground return, which would also cause no output to result. In order to determine if capacitor C2 is open check it with an in-circuit capacitor checker. If, after checking these components, the no output condition still exists the sawtooth sweep voltage must be faulty, or the grid bias supply voltage must be faulty. By checking the sweep voltage input with an oscilloscope and the grid voltage with a voltmeter, the faulty voltage will be located.

Low or Distorted Output. If capacitor C1 becomes shorted the full sawtooth sweep voltage will be placed

across R1, resulting in a sawtooth grid waveform with the grid bias voltage opposing it, and the resultant voltage appearing at the control grid of the CRT. To determine if capacitor C1 is shorted measure the voltage between each plate of C1 and ground. If they are equal the capacitor is shorted. If resistor R1 is shorted no voltage can be developed across it. The voltage applied to the grid of the CRT will then be distorted. To determine if R1 is shorted, check R1 with an ohmmeter. If capacitor C2 were shorted the lower half of R1 would be at d-c ground, and the grid bias supply would be shorted to ground. A certain amount of self grid bias would be generated by the flow of grid current through R1 and any grid signal would probably be distorted if it was large enough to overcome the bias and illuminate the CRT. To determine if C2 is shorted check the voltage between each plate of C2 and ground. If the voltages are equal the capacitor is shorted. If the low or distorted output condition still exists the sawtooth sweep voltage or the grid bias voltage must be faulty. Check the sawtooth sweep voltage with an oscilloscope, and the grid bias voltage with a voltmeter to determine which voltage is at fault.

DC RESTORATION.

APPLICATION.

The d-c restorer is used in CRT display systems to re-establish the d-c level of the composite-video signal, which is lost when the video signal is applied to the CRT control grid through a coupling capacitor from the preceding video amplifier.

CHARACTERISTICS.

Maintains a constant bias level on the CRT control grid.

Receives input from video amplifier load.

Basic components are a diode, a capacitor and resistor.

Output signal waveform varies between the reference level and some positive value, which is determined by the peak-to-peak amplitude of the input waveform.

CIRCUIT ANALYSIS.

General. The d-c restorer consists of a diode connected in parallel with the resistor of a conventional R-C coupling network. The diode is connected so that whenever the waveform swings in a negative direction the diode conducts and produces a short R-C time constant; whenever the waveform swings in a positive direction the diode does not conduct, and this results in a long R-C time constant. Thus, two different time constants are produced—a short time constant during the negative half cycle of the input waveform, and a long time constant during the positive half cycle. It is this difference in time constants that produces a clamped output voltage at the required d-c value, which is applied to the control grid of the CRT.

This voltage restores the d-c component which was blocked by the capacitor coupling the video amplifier signal to the control grid of the CRT.

Circuit Operation. A typical d-c restorer circuit is shown in the accompanying illustration within the dotted lines. The circuitry outside of the dotted lines is included in the illustration to clarify the explanation and function of the d-c restorer.

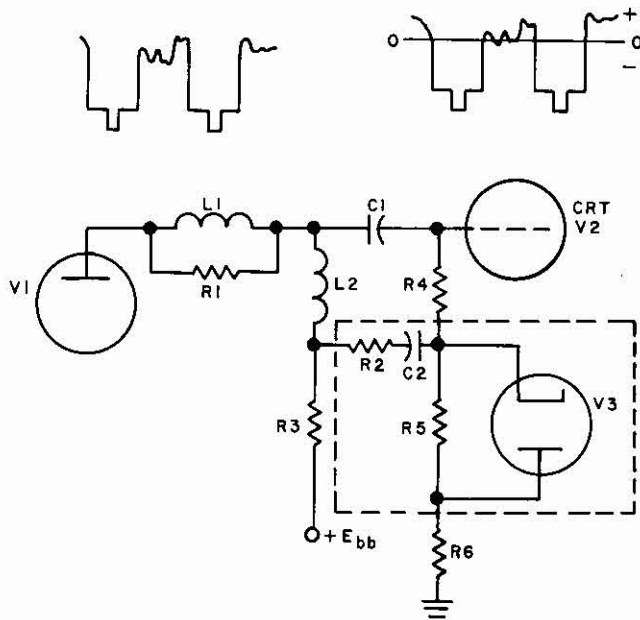

DC Restorer

V1 represents the plate circuit of the video amplifier. L1 and R1 are the series peaking components of the amplifier. L2 is the shunt peaking coil and R3 is the plate load of the video amplifier. C1 couples the plate of V1 to the grid of V2, the cathode ray tube. Resistors R4, R6, and the d-c restorer resistor R5 form a grid leak biasing network for the CRT. Resistor R2 and capacitor C2 couple the video signal to the cathode of d-c restorer diode V3.

As the negative video output pulse appears at the plate of V1, it is capacitively coupled to the CRT grid. Since the coupling capacitor blocks dc, only the ac waveform appears on the grid. Without any d-c restoration arrangement the pulse would establish an average voltage on the CRT grid which would change slightly with each different pulse. As a result, the maximum and minimum levels of the pulse would produce different intensities than they normally would with a fixed bias level. By inserting a d-c restoration circuit which in effect automatically controls the bias on the CRT to compensate for the loss of

the dc component through the coupling circuit, a more faithful waveform reproduction is obtained.

When a negative output is applied through C1 to the CRT grid, a portion of this output is applied to the cathode of d-c restorer diode V3 through R2 and C2, causing the diode to conduct. Current flow through R2, meanwhile, charges capacitor C2 in such a direction that the end of R5 closest to the CRT control grid becomes positive and reduces the total CRT bias. When the video pulse goes positive (becomes less negative) diode V3 ceases conducting. Meanwhile, C2 discharges during the positive portions of the pulse but only very slightly, due to the long time constant to ground offered C2 by R5 and R6. When the video pulse again goes negative, diode V3 conducts and restores the charge on C2 back to its former value. Thus if the average brightness is high, the negative swing from maximum positive to maximum negative value is greater, and diode V3 conducts longer causing a greater peak current flow and a greater positive charge appears across C2. Hence the CRT bias decreases further producing the greater brilliance. Conversely, when the negative swing applied to V3 is smaller, conduction of V3 occurs for a smaller period and less voltage is developed across C2. Consequently, the CRT negative bias increases by the reduction of charge voltage developed across C2 and a less brilliant signal appears. Parts values are normally chosen so the CRT bias is normal with V3 operating.

FAILURE ANALYSIS.

No Output. Normally, failure of the d-c restorer circuit will cause the CRT presentation to appear darker than normal. A quick check on operation is to remove diode V3 and note if the presentation changes. If there is no change, either the diode is defective or a faulty component exists. Check resistor R5 for proper value with an ohmmeter. With R5 shorted the d-c restorer will not operate. If R5 is open no bias voltage will appear on the CRT grid when checked with a voltmeter. Also check R2 with an ohmmeter for proper value. If capacitor C2 is open the restorer will not operate, check C2 for value with an in-circuit capacitance checker. If C2 is shorted a positive bias will be placed on the grid of the CRT, and in all probability the CRT will be constantly illuminated. Do not neglect to check the values of R4 and R6 with an ohmmeter since they are a portion of a voltage divider across which the d-c restorer operates. If either is open no output will occur, but a change in value will not necessarily cause no output.

Improper Output. A defective V3 can cause a dark or distorted presentation. A shorted C2 can cause constantly illuminated display, check C2 with an in-circuit capacitance checker. It is important to remember that distortion or improper waveforms can occur in circuits prior to the d-c restorer.

Therefore, when in doubt check both sides of C1 to ground with an oscilloscope. If the trouble exists on the input side of C1 the cause is not the d-c restorer. If the trouble appears on both sides of C1 it is still necessary to

the total power present. The resistive load of V3 and the resistive load of the deflection coils require a slight linear increase in the amplitude of the induced square wave to produce the required sawtooth current for the deflection coils. This is provided initially by a small amount of stored voltage in the coils.

The retrace of the sawtooth sweep causes the secondary voltage of T1 to drop to zero. This, in turn, causes the current in the deflection coils to collapse, and shock excites into oscillation the resonant circuit formed by the deflection coils and distributed capacity (the oscillation frequency is in the vicinity of 75 KHz). The first alternation of the flyback oscillation is a sharp negative pulse of high potential and V3 does not conduct during this negative transient. This negative spike, however, also appears across the secondary of T1 and it is inductively coupled into the primary of T1. Here it is stepped up to a very high positive voltage by the large number of turns of the complete primary of T1. This voltage causes high voltage rectifier tube V2 to conduct and rectify the positive kickback pulses. The pulsating d-c voltage from the high voltage rectifier is varying at a high ripple frequency and is easily filtered by the RC arrangement of capacitors C4, and C5, and series resistor R2, and is applied to the second anode of the CRT.

When a positive transient appears on the plate of V3, damper tube V3 conducts heavily. The oscillating transient is heavily damped by the load placed across the deflection coils by the damper tube. Before the transient oscillations are completely eliminated, however, the sawtooth sweep begins again. The combination of the heavily damped oscillations and the increasing sawtooth input produces a slight linear increase in the deflection coil current at the start of the sweep.

During the time that V3 is conducting, dc voltage is applied to the filter network consisting of capacitors C1 and C2 and inductance L2. This voltage is connected in series with the voltage from the low-voltage power supply and provides a small d-c voltage boost.

FAILURE ANALYSIS.

Note:

Although this type of circuit is designed to supply only a small output current from the high voltage supply to prevent lethal shock, be careful to observe standard high voltage safety precautions. It is important to discharge both the CRT anode and the high voltage filter capacitors before making voltage or resistance checks on the high voltage portions of this circuit.

No Output. Assuming that the input of this circuit, which is the output from the horizontal sweep output amplifier, is correct, a no-output condition could occur if the primary of T1 were shorted or open. In either case no voltage would be coupled to the secondary of T1, and no voltage would appear on the plate of the high voltage rectifier V2. Thus there would be no sweep voltage produced by the deflection coils, or high voltage on the second anode of the CRT. To determine whether or not T1 is defective,

measure the d-c resistance of the primary of T1 with an ohmmeter. Likewise, if the secondary of T1 were open or shorted, no voltage could be coupled to the deflection coils, and no large negative kickback pulse would be developed for the production of the high voltage for the second anode of the CRT. To determine if the secondary of T1 is shorted or open check the d-c resistance value of the secondary with an ohmmeter.

If horizontal deflection coils L3 and L4 were shorted or open no sweep would be produced and, likewise, no negative pulse would be developed for the production of the high voltage and the CRT would not be illuminated. To determine if L3 and L4 are open or shorted measure their dc resistance value with an ohmmeter.

If capacitor C6 were open no sweep voltage would be produced and no high voltage would be produced. Check the value of capacitor C6 with an in-circuit capacitor checker to determine if it is open.

Low or Distorted Output. If the input of this circuit is correct a low or distorted output could exist if T1 were partially shorted. Check the d-c resistance values of the primary and the two secondaries with an ohmmeter.

If either L3 or L4 is shorted, or partially shorted, the sweep voltage will be distorted and a distorted pattern will appear on the CRT. While an improper kickback voltage value may be coupled to the plate of the high voltage rectifier the distortion may not create sufficient difference in value to show on a voltage check. Measure the dc resistance of L3 and L4 with an ohmmeter.

If capacitor C3 were shorted the same effect as a shorted inductance L3 would occur. To determine if C3 is shorted check C3 with an in-circuit capacitor checker.

If inductance L1 were shorted or open, the voltage coupled from the primary to the secondary of T1 would be lower than normal resulting in a smaller sweep and a lower high voltage value. To determine if inductance L1 is shorted or open check the dc resistance value with an ohmmeter.

If diode V3 is shorted, the sweep voltage will be greatly decreased and show a smaller pattern on the CRT. The high voltage at the cathode of V2 will also be lower than normal, and the boost voltage will also be low.

If filter components C1, L2, or C2 were defective the boost voltage would be lower than normal. To determine if any of these components are defective, check capacitors C1 and C2 with an in-circuit capacitor check, and check the dc resistance of L2 with an ohmmeter.

If diode V2 were shorted or open no high voltage would appear on the CRT and the presentation would not appear. Check the voltage from the filament of V2 to ground. If resistor R1 were open, V2 would not conduct and no high voltage would be available at the second anode of the CRT. Observe whether or not the filament appears to be illuminated, if not check R1, for value with an ohmmeter.

If capacitor C4 were shorted, the high voltage would

be grounded and none would be available at the second anode of the CRT. Measure the voltage from C4 to ground, if it is low or zero check C4 for proper value with an in-circuit capacitor checker. If resistor R2 is open no high voltage would be available at the second anode of the CRT. Measure the voltage of C4 and C5 to ground with a voltmeter. If the voltage on C4 is normal but voltage appears across C5, check the resistance value of R2 with an ohmmeter. If capacitor C5 were shorted the high voltage would be shorted to ground. Check C5 with an in-circuit capacitor checker.

