

TECHNICAL MANUAL  
OPERATION AND MAINTENANCE INSTRUCTIONS  
TELEGRAPH - TELEPHONE  
SIGNAL CONVERTER  
CV-2460/SGC



THIS MANUAL SUPERSEDES TECHNICAL MANUAL  
NAVELEX 0967-LP-386-3010 DATED AUGUST 1970.

DISTRIBUTION LIMITED TO U.S. GOVERNMENT  
AGENCIES ONLY, (TEST AND EVALUATION):

1 DECEMBER 1981

REQUESTS FOR THIS DOCUMENT MUST BE  
REFERRED TO THE COMMANDER, NAVAL  
ELECTRONIC SYSTEMS COMMAND.

---

PUBLISHED BY DIRECTION OF COMMANDER, NAVAL ELECTRONIC SYSTEMS COMMAND

**FOR OFFICIAL USE ONLY**

**1 DECEMBER 1981**

# LIST OF EFFECTIVE PAGES

NOTE: The portion of the text affected by the changes is indicated by a vertical line in the outer margins of the page. Changes to illustrations are indicated by miniature pointing hands. Changes to wiring diagrams are indicated by shaded areas.

Dates of issue for original and changed pages are: 1 December 1981

TOTAL NUMBER OF PAGES IN THIS PUBLICATION IS 150 CONSISTING OF THE FOLLOWING:

Page No.	*Change No.	Page No.	*Change No.
COVER	0	5-25/(5-26 Blank)	0
TITLE/A	0	5-27/(5-28 Blank)	0
B/(C Blank)	0	5-29/(5-30 Blank)	0
i/v	0	5-31/(5-32 Blank)	0
1-0/1-10	0	5-33/(5-34 Blank)	0
2-1/2-8	0	5-35/(5-36 Blank)	0
3-1/3-4	0	5-37/(5-38 Blank)	0
3-5/(3-6 Blank)	0	5-39/(5-40 Blank)	0
3-7/(3-8 Blank)	0	6-1/6-2	0
3-9/3-10	0	6-3/(6-4 Blank)	0
3-11/(3-12 Blank)	C	7-1/7-36	0
3-13/3-16	0	8-1/8-2	0
3-17/(3-18 Blank)	0	8-3/(8-4 Blank)	0
4-1/4-2	0	8-5/(8-6 Blank)	0
5-1/5-14	0	8-7/8-10	0
5-15/(5-16 Blank)	0	8-11/(8-12 Blank)	0
5-17/(5-19 Blank)	0	Glossary-1	0
5-19/(5-20 Blank)	0	Index-1/Index-6	0
5-21/(5-22 Blank)	0		
5-23/(5-24 Blank)	0		

\*Zero in this column indicates an original page.





## TABLE OF CONTENTS

Chapter/Paragraph		Page
1	GENERAL INFORMATION AND SAFETY PRECAUTIONS	1-1
1-1	SAFETY PRECAUTIONS	1-1
1-2	INTRODUCTION	1-1
1-3	EQUIPMENT DESCRIPTION	1-2
1-3.1	Physical Description	1-2
1-3.2	Functional Description	1-2
1-3.3	Send and Receive Options	1-8
1-4	RELATIONSHIP OF UNITS	1-8
1-5	REFERENCE DATA	1-8
1-6	EQUIPMENT ACCESSORIES AND DOCUMENTS SUPPLIED	1-8
1-7	EQUIPMENT AND PUBLICATIONS REQUIRED, BUT NOT SUPPLIED	1-8
1-8	FACTORY CHANGES AND FIELD CHANGES	1-8
2	OPERATION	2-1
2-1	INTRODUCTION	2-1
2-1.1	Send Section	2-1
2-1.2	Receive Section	2-1
2-1.3	Control Section	2-1
2-2	CONTROLS AND INDICATORS	2-1
2-3	OPERATING PROCEDURE	2-1
2-3.1	Operation	2-1
2-3.2	Setup	2-1
2-3.3	Signal Level Adjustment	2-6
2-3.4	Routine Operation	2-6
2-3.5	Stopping	2-7
2-4	OPERATOR'S MAINTENANCE	2-7
2-4.1	Preventive Maintenance	2-7
2-4.2	Emergency Maintenance	2-7
3	FUNCTIONAL DESCRIPTION	3-1
3-1	INTRODUCTION	3-1
3-2	OVERALL FUNCTIONAL DESCRIPTION	3-1
3-2.1	Send Input Circuits	3-1
3-2.2	Tone Keying Circuits	3-1
3-2.3	Receive Input Circuits	3-1
3-2.4	Loop Keying Circuits	3-1
3-2.5	Control Circuits	3-1
3-2.5.1	Receive Only	3-1
3-2.5.2	Send Only	3-1
3-2.5.3	Automatic Half-Duplex	3-1
3-2.5.4	Full Duplex	3-2
3-2.5.5	Back-to-Back	3-2
3-2.6	Meter Circuits	3-3

TABLE OF CONTENTS (Continued)

Chapter/Paragraph		Page
3-2.7	Power Supply	3-3
3-3	FUNCTIONAL SECTION DESCRIPTION	3-3
3-4	SEND INPUT CIRCUITS	3-3
3-5	TONE KEYING CIRCUITS	3-3
3-6	RECEIVE INPUT CIRCUITS	3-4
3-7	PRODUCT DETECTOR	3-9
3-8	LOOP KEYING CIRCUITS	3-10
3-9	CONTROL CIRCUITS	3-13
3-9.1	Control Network	3-13
3-9.2	Receive Only	3-15
3-9.3	Send Only	3-15
3-9.4	Full Duplex	3-15
3-9.5	Back-to-Back	3-15
3-9.6	Half-Duplex	3-15
3-10	METER CIRCUITS	3-16
3-11	POWER SUPPLY	3-17
4	SCHEDULED MAINTENANCE	4-1
4-1	INTRODUCTION	4-1
4-2	PREVENTIVE MAINTENANCE	4-1
4-2.1	Operator's Procedure	4-1
4-2.2	Technician's Procedure	4-1
4-3	SCHEDULED MAINTENANCE	4-2
4-4	SCHEDULED PERFORMANCE TESTS	4-2
5	TROUBLESHOOTING	5-1
5-1	INTRODUCTION	5-1
5-2	LOGICAL TROUBLESHOOTING	5-1
5-2.1	Symptom Recognition	5-1
5-2.2	Symptom Elaboration	5-1
5-2.3	Listing Probable Faulty Function	5-1
5-2.4	Localizing the Faulty Function	5-1
5-2.5	Localizing Trouble to the Circuit	5-2
5-2.6	Failure Analysis	5-2
5-3	TROUBLESHOOTING PROCEDURE	5-2
5-3.1	Fault Isolation	5-3
5-3.2	Diagrams	5-3
6	CORRECTIVE MAINTENANCE	6-1
6-1	INTRODUCTION	6-1
6-2	ADJUSTMENTS AND ALIGNMENT	6-1
6-2.1	Front Panel Removal	6-1
6-2.2	Test Equipment Required	6-1
6-2.3	Preliminary Set-Up	6-1
6-2.4	Meter Movement	6-2

## TABLE OF CONTENTS (Continued)

Chapter/Paragraph		Page
6-2.5	Receive Bias	6-2
6-2.6	Send Delay	6-2
6-2.7	Receive Delay	6-2
6-2.8	Low Band Oscillator Frequencies	6-2
6-2.9	High Band Oscillator Frequencies	6-3
6-3	REPAIR	6-3
7	PARTS LIST	7-1
7-1	INTRODUCTION	7-1
7-2	LIST OF MAJOR ASSEMBLIES	7-1
7-3	MAINTENANCE PARTS LIST	7-1
7-4	LIST OF MANUFACTURERS	7-1
8	INSTALLATION	8-1
8-1	INTRODUCTION	8-1
8-2	UNPACKING AND REPACKING INSTRUCTIONS	8-1
8-3	VISUAL INSPECTION	8-1
8-4	POWER REQUIREMENTS	8-1
8-5	SITE SELECTION	8-1
8-6	MOUNTING	8-2
8-6.1	Tools and Materials Required for Installation	8-2
8-6.2	Rack Mounting	8-2
8-6.3	Bench Mounting	8-2
8-7	STRAPPING	8-7
8-8	CONNECTIONS	8-7
8-9	INITIAL POWER APPLICATION	8-7
8-10	INITIAL CHECKS AND ADJUSTMENTS	8-7
GLOSSARY		GLOSSARY-1
INDEX		INDEX-1

## LIST OF FIGURES

Figure	Title	Page
1-1	Telegraph-Telephone Signal Converter CV-2460/SGC	1-0
1-2	System Application	1-5
2-1	Functional Block Diagram	2-2
2-2	Controls and Indicators	2-2
3-1	Simplified Overall Block Diagram	3-2
3-2	Detailed Overall Block Diagram	3-5
3-3	Frequency Discriminator Circuits	3-11
5-1	Back-to-Back Configuration	5-8
5-2	Chassis Parts Location, Front Panel	5-9
5-3	Chassis Parts Location, Interior	5-9
5-4	Power Supply, Module 1A1, Parts Location	5-11
5-5	Power Supply, Module 1A1, Wiring Diagram	5-12
5-6	Power Supply, Module 1A1, Schematic Diagram	5-13
5-7	Primary Power Distribution	5-14
5-8	Component Board 1A2 (Send and Input), Wiring Diagram and Parts Location	5-15
5-9	Component Board 1A2 (Send and Input), Schematic Diagram	5-17
5-10	Component Boards 1A3 (Oscillator A) and 1A4 (Oscillator B), Wiring Diagram and Parts Location	5-19
5-11	Component Boards 1A3 (Oscillator A) and 1A4 (Oscillator B), Schematic Diagram	5-21
5-12	Component Board 1A5 (Control Network), Wiring Diagram and Parts Location	5-23
5-13	Component Board 1A5 (Control Network), Schematic Diagram	5-25
5-14	Component Board 1A5 (Receive), Wiring Diagram and Parts Location	5-27
5-15	Component Board 1A6 (Receive), Schematic Diagram	5-29
5-16	Component Board 1A7 (Loop Keying Network), Parts Location	5-31
5-17	Component Board 1A7 (Loop Keying Network), Schematic Diagram	5-33
5-18	Component Boards 1A8 (Receive Filter, Low Band, and 1A9 (Receive Filter, High Band), Parts Location	5-35
5-19	Component Boards 1A8 (Receive Filter, Low Band) and 1A9 (Receive Filter, High Band), Schematic Diagram	5-37
5-20	Converter Wiring Diagram	5-39
8-1	System Installation	8-3



## LIST OF FIGURES (Continued)

Figure	Title	Page
8-2	Mounting Dimensions	8-5
8-3	Strapping	8-8
8-4	Connections	8-8

## LIST OF TABLES

Table	Title	Page
1-1	Equipment, Accessories, and Documents Supplied	1-3
1-2	Equipment and Publications Required, But Not Supplied	1-4
1-3	Reference Data	1-9
1-4	Operating Parameters	1-9
1-5	Record of Factory Changes	1-10
1-6	Record of Field Changes	1-10
2-1	Controls and Indicators	2-3
2-2	Turn-on Procedures	2-5
3-1	Control Circuit Functions	3-14
5-1	Fault Isolation Procedures	5-4
7-1	List of Major Assemblies	7-2
7-2	Maintenance Parts List for Module 1A1	7-3
7-3	Maintenance Parts List for Module 1A2	7-5
7-4	Maintenance Parts List for Module 1A3	7-9
7-5	Maintenance Parts List for Module 1A4	7-12
7-6	Maintenance Parts List for Module 1A5	7-15
7-7	Maintenance Parts List for Module 1A6	7-19
7-8	Maintenance Parts List for Module 1A7	7-25
7-9	Maintenance Parts List for Module 1A8	7-28
7-10	Maintenance Parts List for Module 1A9	7-30
7-11	Maintenance Parts List for Module 1A10	7-32
7-12	Maintenance Parts List for Chassis 1A11	7-33
7-13	List of Manufacturers	7-36
8-1	Strapping Options	8-8
8-2	Connections	8-9

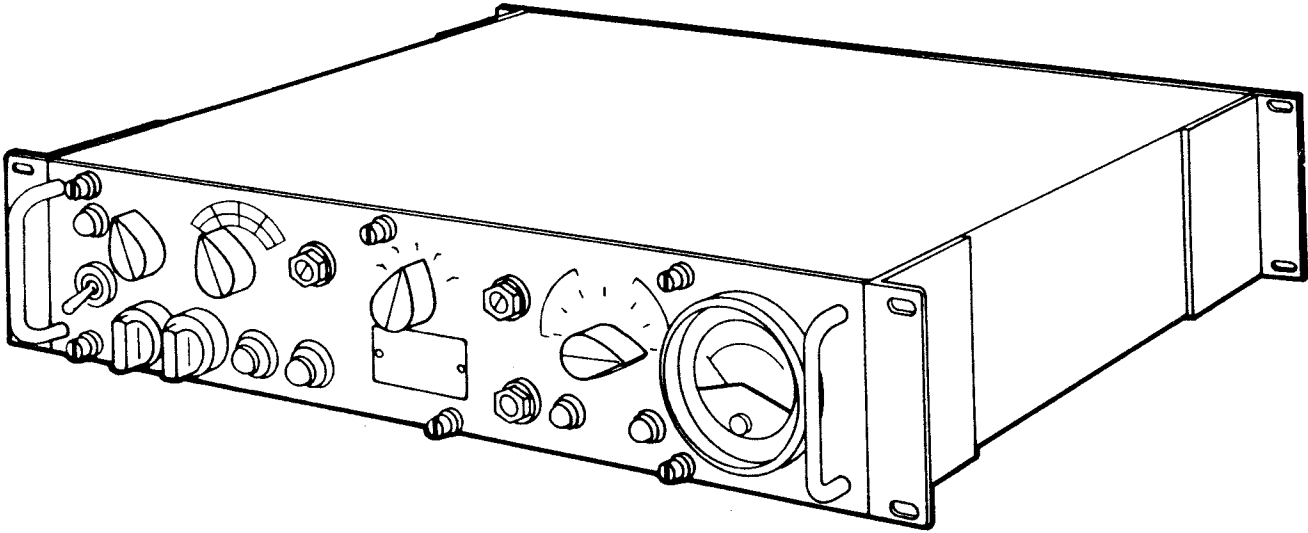

Figure 1-1. Telegraph-Telephone Signal Converter CV-2460/SGC

## CHAPTER 1

## GENERAL INFORMATION AND SAFETY PRECAUTIONS

1-1. SAFETY PRECAUTIONS. During normal operation and/or maintenance of this equipment, situations may arise in which the possibility of hazard to personnel or damage to the equipment is greatly increased. These possibilities are denoted throughout this manual and are indicated in boldface type as WARNING or CAUTION. The warnings and cautions are listed below with the appropriate references to their paragraph positions.

WARNING

Dangerous voltages exist inside this unit which could cause loss of life or serious injury. (Para. 2-3c(2); 4-1; 5-3a; 6-2.1; 8-3c; and 8-10.)

WARNING

Fuse holders and fuse terminals carry dangerous voltages which could cause personal injury. (Para. 2-4.2.)

WARNING

Make sure that all external wires are not energized before making connections. Wires may connect to dangerous voltages, which could cause personal injury. (Para. 8-8).

CAUTION

Failure to deenergize external  $\pm 6$  volt power supply when FAILURE WHEN LIT indicator lights could cause additional damage to the converter. (Para. 2-4.2a.)

1-2. INTRODUCTION. This manual describes installation, operation, troubleshooting, and maintenance procedures. This manual also provides a parts list for the Telegraph-Telephone Signal Converter CV-2460/SGC (figure 1-1), hereafter referred to as the Converter. This manual is in effect upon receipt and supersedes Technical Manual NAVELEX 0967-LP-386-3010 dated August 1970. Extracts from this manual may be made to facilitate the preparation of other Department of Defense publications.

## 1-3. EQUIPMENT DESCRIPTION.

1-3.1. Physical Description. The Converter is housed in a fixed enclosure that facilitates either rack or bench mounting. The enclosure contains eight plug-in component boards, a component board extender, a plug-in power supply module with test power cord, two heat-shunted power resistors, two feed-through capacitors, and two terminal boards. All controls and indicators are located at the front of the unit. The front panel slides out and swings up to expose all components for servicing and adjustment. All external power, control, and signal lines are connected to two terminal boards located beneath an access cover at the top, left, rear of the enclosure. External lines lead in through either of two inlets. One entry, located beneath the terminal boards, is used for bench installation. The other entry, located behind the terminal boards, is used for rack installation. Four L-brackets, stored on the rear of the unit, are used to mount the Converter in any standard 19-inch relay rack. Four bolts stored on the rear of the unit are used to secure the unit to four standard shock mounts (not supplied) for bench mounting. A front panel meter permits switch-selectable monitoring of all input and output signals for setup, adjustment, and maintenance. Table 1-1 lists the equipment supplied, and table 1-2 lists the test equipment required, but not supplied, for maintenance.

1-3.2. Functional Description. The Converter contains the signal conversion circuitry required to implement one channel of duplex data communications via a radio/telephone channel. The send section converts dc loop data to frequency-shift tone data, and the receive section converts frequency-shift tone data to dc loop data. A control section permits operation in any one of five switch-selectable modes:

- a. In the receive-only mode, the send section is inoperative.
- b. In the send-only mode, the receive section is inoperative.
- c. In the automatic half-duplex mode (figure 1-2, view A and view B), both sections are in standby with no signals applied. When the send-signal becomes active, the receive section is inhibited until the send signal ceases. When the receive signal is active, the send section is inhibited until the receive signal ceases. While the send section is active, a voice operated transmitter keyer (VOX) closure is applied to operate the associated radio transmitter. Therefore, the automatic mode permits half or full duplex carrier channel communications, using a consolidated sending/receiving device (such as a teletypewriter) without send-receive channel switching being required of the operator. The local consolidated loop cannot be keyed by a receive signal while being keyed locally.
- d. In the full-duplex mode (FDX) (figure 1-2, view C), both sections are independently operative.

Table 1-1. Equipment, Accessories, and Documents Supplied

QTY PER EQUIP	NOMENCLATURE	DIMENSIONS (IN.)			VOLUME (CU. IN.)	WEIGHT (LB)
		HEIGHT	WIDTH	DEPTH		
1	Converter, Telegraph- Telephone Signal, CV-2460/SGC	3.47	19	16.06	1059	24
8	Plug-In Component Board (PCB)	-	-	-	-	*
1	Plug-In Power Supply Module, with Test Cord	-	-	-	-	*
1	Component Board Extender	-	-	-	-	*
4	L-Bracket	-	-	-	-	*
16	L-Bracket Screws	-	-	-	-	*
4	Shock-Mount Bolts	-	-	-	-	*
1	Spare Fuse	-	-	-	-	*
1	Technical Manual for Converter, Telegraph-Telephone Signal, CV-2460/SGC, EE162-AB-MMO-010/E110 CV2460	11	8.5	.5	46.75	1.25

\*Weight included in basic unit.

Table 1-2. Equipment and Publications Required, But Not Supplied

SCAT NO.	NOMENCLATURE		APPLICATION
	CATEGORY	MODEL/DESIGNATION (or equivalent)	
4245	Multimeter, AC-DC	AN/PSM-4D	Troubleshooting and maintenance
4206	Voltmeter, AC VTVM	ME-6D/U	Troubleshooting and maintenance
4308	Oscilloscope	AN/USM-281	Troubleshooting and maintenance
4585	Generator Distortion, TTY	AN/UGM-8	Troubleshooting and maintenance
4388	Oscillator, Audio	HP-200CD	Troubleshooting and maintenance
4557	Test Set, Semi-conductor	TS-1100A/U	Troubleshooting and maintenance
4995	Counter, Electronic	HP-5223L	Troubleshooting and maintenance
N/A	Attenuator	TS-402/U	Troubleshooting and maintenance
N/A	Instruction Book for AN/PSM-4D	NAVELEX 0967-911-6010	
N/A	Instruction Book for ME-6D/U	NAVELEX 0967-091-0010	
N/A	Instruction Book for AN/USM-281	NAVELEX 0969-244-3010	
N/A	Instruction Book for AN/UGM-8	NAVELEX 0967-328-9010	
N/A	Instruction Book for HP-200CD		
N/A	Instruction Book for TS-402/U	TM 11-2044*	
N/A	Instruction Book for TS/1100A/U	NAVELEX 0967-926-3010	
N/A	Instruction Book for HP-5223L		

\*Department of the Army Technical Manual.

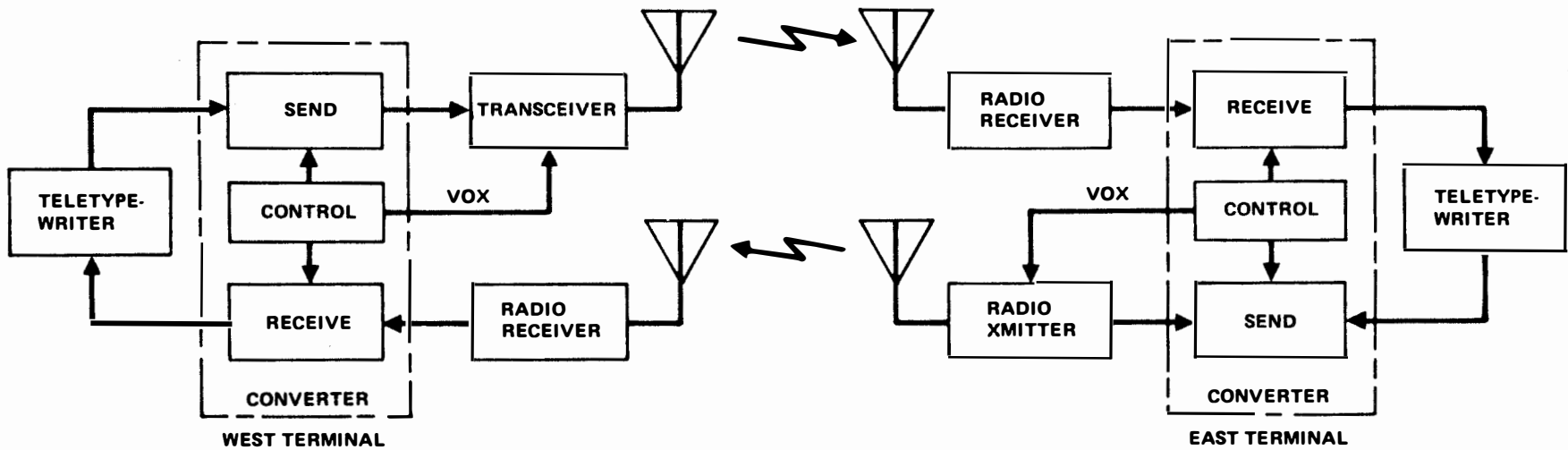

A. HALF DUPLEX LOOP-FULL DUPLEX CARRIER

Figure 1-2. System Application (Sheet 1 of 3)

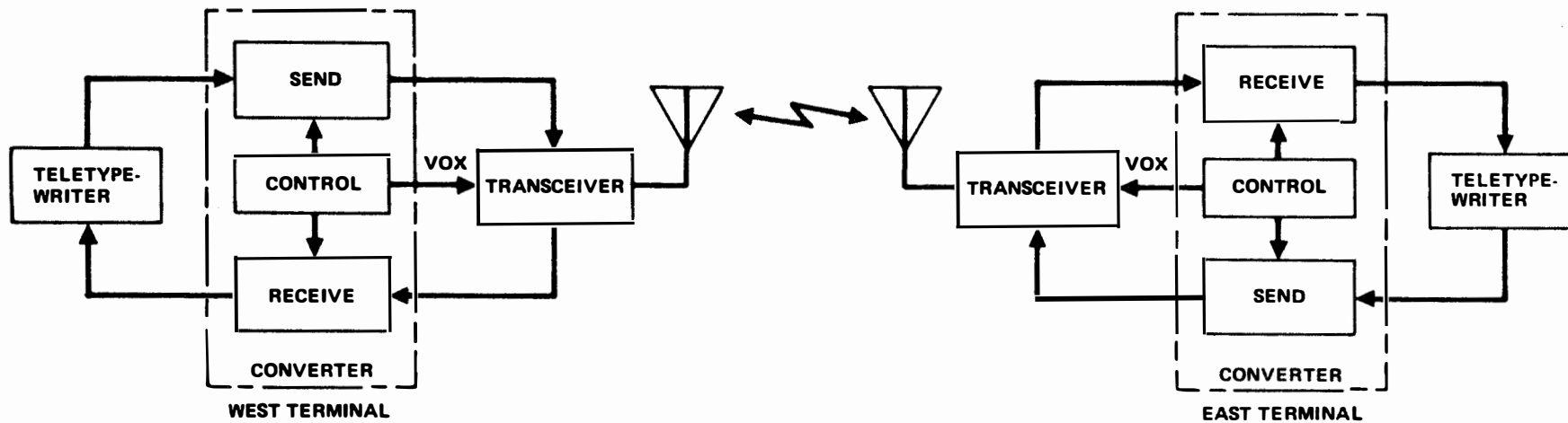

B. HALF DUPLEX LOOP-HALF DUPLEX CARRIER

Figure 1-2. System Application (Sheet 2 of 3)



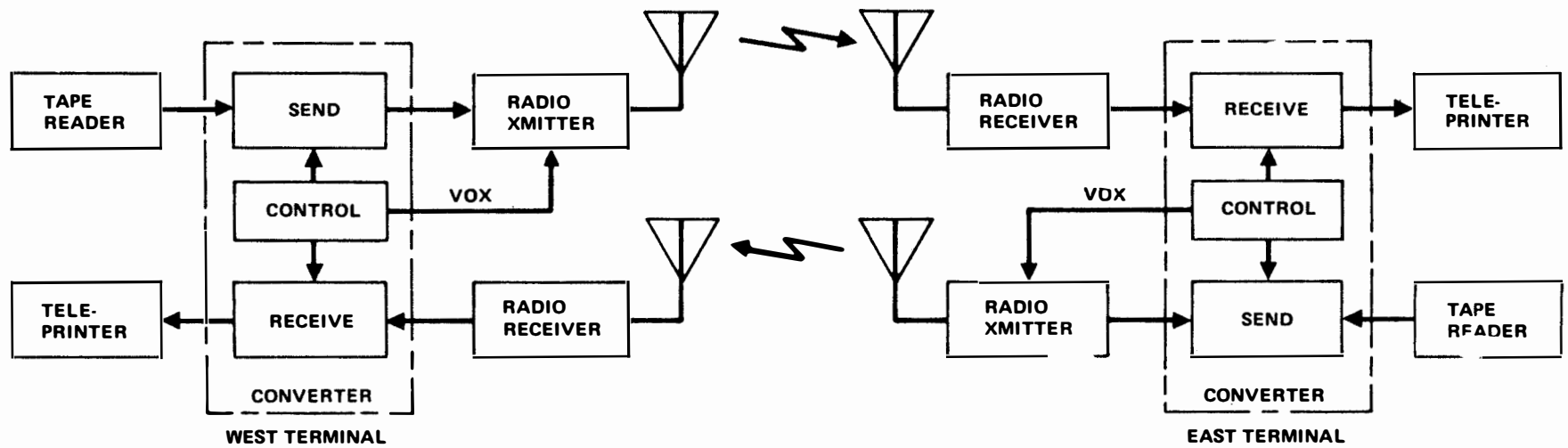

C. FULL DUPLEX LOOP-FULL DUPLEX CARRIER

Figure 1-2. System Application (Sheet 3 of 3)

e. In the back-to-back mode (S/R BTB), both sections are operative, except the variable frequency (vf) output of the send section is connected to the input of the receive section for maintenance.

1-3.3 Send and Receive Options. The Converter will operate in any one of three send and receive configurations, depending on the operating station requirements. Determine which send and which receive configuration is required for your station (from those listed below) and refer to Strapping Options in chapter 8 for proper strap installation.

<u>SEND Option</u>	<u>RECEIVE Option</u>
20 mA neutral	High-level current
60 mA neutral	High-level voltage
Low-level polar	Low-level polar

1-4. RELATIONSHIP OF UNITS. The relationship of units are shown in figure 1-1.

1-5. REFERENCE DATA. The reference data for the Converter is listed in table 1-3. The operating parameters are listed in table 1-4.

1-6. EQUIPMENT, ACCESSORIES, AND DOCUMENTS SUPPLIED. Refer to table 1-1 for equipment, accessories, and documents supplied with the Converter.

1-7. EQUIPMENT AND PUBLICATIONS REQUIRED, BUT NOT SUPPLIED. Refer to table 1-2 for other equipment and documents required to operate or test the Converter that are not supplied.

1-8. FACTORY CHANGES AND FIELD CHANGES. Table 1-5, Record of Factory Changes and table 1-6, Record of Field Changes are provided to identify those factory and field changes which have been incorporated in this manual. These tables identify the affected equipment serial numbers and include a brief description of the incorporated change.

Table 1-3. Reference Data

ITEM	DESCRIPTION
Nameplate Data	CV-2460/SGC Converter, Telegraph- Telephone Signal
Input Power	115V 1Ø, 47-63 Hz, 20W
Ambient Temperature	0 <sup>0</sup> to 50 <sup>0</sup> C (32 <sup>0</sup> to 122 <sup>0</sup> F)
Relative Humidity	95% maximum

Table 1-4. Operating Parameters

CHARACTERISTICS	DESCRIPTION
Level Difference	2 dB maximum between mark and space tones of tone data signal.
Keying Transients	10% change, maximum, in magnitude of carrier envelope.
Signal Sense	Normal and Reverse (send), Normal and Reverse (receive).
Signal Levels:	
Tone-data, send	-30 to +10 dBm continuously adjustable
Tone-data, receive	Accepts 0 to -40 dBm
High band	Space: 1575 Hz Mark: 2425 Hz
Low band	Space: 500 Hz Mark: 700 Hz
Peak Distortion, Introduced by Converter	5% maximum
Loop Battery	External
Loop Options:	
Send	20 mA neutral 60 mA neutral
Receive	Low-level polar High-level current High-level voltage Low-level polar

Table 1-5. Record of Factory Changes

CHANGE NO.	NOMENCLATURE AND SERIAL NUMBERS AFFECTED	DESCRIPTION AND PURPOSE OF CHANGES
1	CV-2460/SGC, all serial numbers after 582	Increases compatibility with respect to variation in system configurations

Table 1-6. Record of Field Changes

CHANGE NO.	NOMENCLATURE AND SERIAL NUMBERS AFFECTED	DESCRIPTION AND PURPOSE OF CHANGES
1	CV-2460/SGC all serial numbers	Installation of VOX closure relay 1A11A1K1
2	CV-2460/SGC serial numbers 1 thru 582	Increases compatibility with respect to variation in system configurations
3	CV-2460/SGC all serial numbers	Delete the SEND BIAS adjustments (1A2A2A1R12) and replace it with 2 fixed resistor voltage dividers

## CHAPTER 2

## OPERATION

2-1. INTRODUCTION. The Converter consists of three sections: send, receive, and control (figure 2-1).

2-1.1. Send Section. Converts a dc-data signal to a frequency-shift tone-data signal (high band or low band) for transmission, via a radio/telephone channel to a distant Converter.

2-1.2. Receive Section. Converts a tone-data signal (high band or low band), received from a distant Converter, to a dc-data signal.

2-1.3. Control Section. Conditions the send and receive sections, via control signals, to operate in the receive, send, standby (half-duplex), or full-duplex mode, as selected by the MODE switch.

a. Receive Mode. Receive section enabled, send section disabled.

b. Send Mode. Send section enabled, receive section disabled.

c. Standby Mode. Both send and receive sections remain in standby until either a send or receive signal is applied.

(1) When a send dc-data signal is applied, the control section enables the send section and disables the receive section until the send dc-data signal ceases. While the send signal is active, any receive signals will be rejected. The VOX output provides a closure to enable the associated radio transmitter.

(2) When a receive tone-data is applied, the control section enables the receive section and disables the send section until the receive tone-data signal ceases. While the receive signal is active, any send signals will be rejected. The VOX closure opens to disable the associated radio transmitter.

d. Full-Duplex Mode. Both send and receive sections enabled.

2-2. CONTROLS AND INDICATORS. Figure 2-2 illustrates the front panel controls and indicators. Table 2-1 describes the function of each of those controls and indicators.

2-3. OPERATING PROCEDURE.

2-3.1. Operation. For operation of the Converter, refer to table 2-2.

2-3.2. Setup. When the Converter is initially installed and whenever the system configuration is changed, refer to chapter 8 for initial checkout.

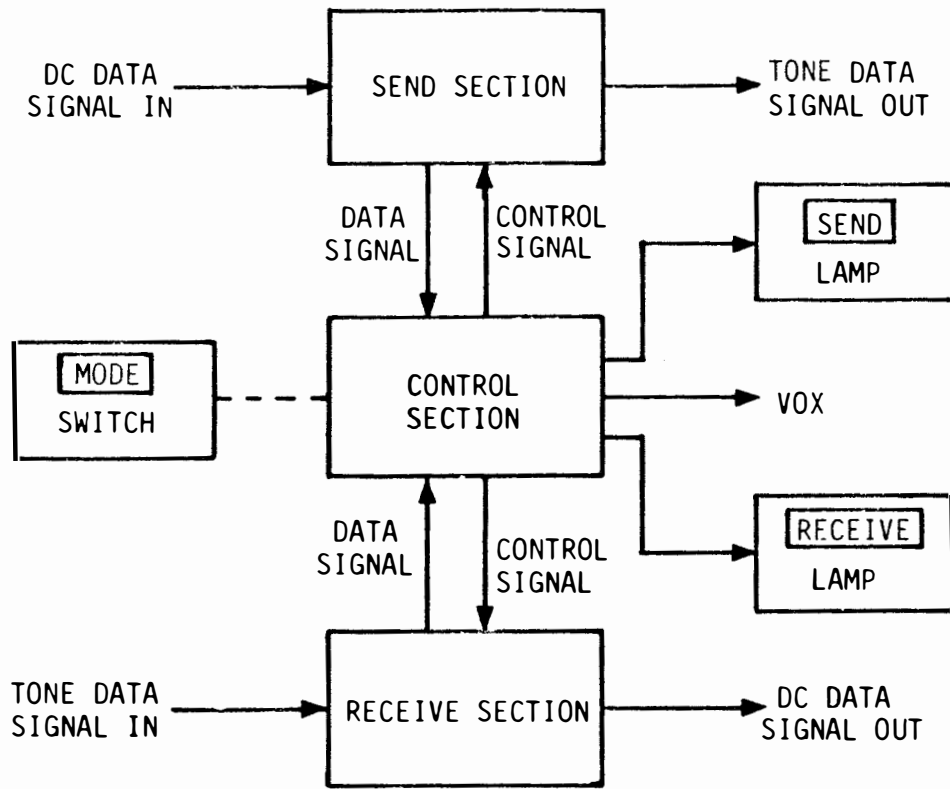

Figure 2-1. Functional Block Diagram

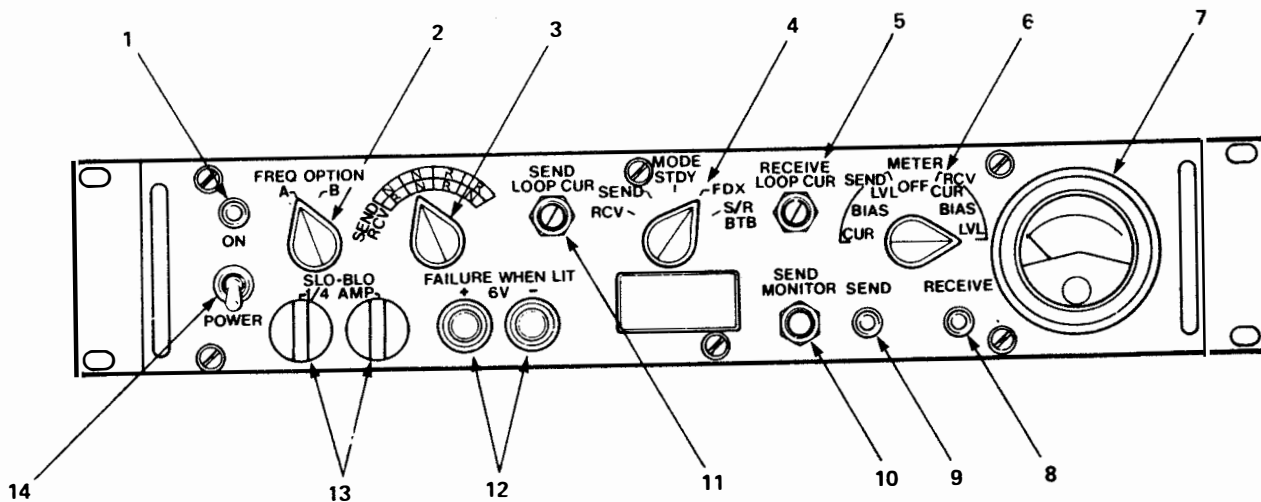

Figure 2-2. Controls and Indicators

Table 2-1. Controls and Indicators

FIG. INDEX NO.	CONTROL/ INDICATOR	FUNCTION
1. 2.	POWER indicator (Red) FREQ OPTION switch 2-position rotary switch A position  B position	Illuminates when POWER switch is ON.  Conditions send and receive sections to operate in a low band (500 Hz space and 700 Hz mark). Conditions send and receive sections to operate in the high band (1575 Hz space and 2425 Hz mark).
3.	KEYING switch 4-position rotary switch SEND          RCV N                R  N                N  R                R  R                N	Send normal sense, receive reverse sense. Send normal sense, receive normal sense. Send reverse sense, receive reverse sense. Send reverse sense, receive normal sense.
4.	MODE switch 5-position switch RCV SEND STBY FDX S/R BTB	Selects receive only operation. Selects send only operation. Selects half-duplex operation. Selects full-duplex operation *NOT USED BY OPERATOR. In send/ receive, back-to-back position, external tone line is connected to input network and selects full-duplex operation. Used for loop-back testing.
5.	RECEIVE LOOP CUR rheostat	Adjusts receive loop current.
6.	METER 8-position rotary switch SEND C1'R	Meter indicates send dc data signal level (current).

Table 2-1. Controls and Indicators--(continued)

FIG. INDEX NO.	CONTROL/ INDICATOR	FUNCTION
	SEND BIAS	*Meter indicates input signal bias distortion level (voltage).
	SEND LVL	Meter indicates send tone-data signal level (dBm).
	OFF	Meter is disconnected from all circuits.
	RCV CUR	Meter indicates receive dc-data signal level (current).
	RCV BIAS	*Meter indicates output signal bias distortion level (voltage).
	RCV LVL	Meter indicates receive tone signal data signal level (dBm).
	V	*Meter indicates voltage across power supply voltage divider.
7.	Meter	Indicates input and output signal levels and provides indication of bias adjustment as selected by METER switch.
8.	RECEIVE indicator (blue)	Illuminates when receive section is enabled and receive signal is active.
9.	SEND indicator (green)	Illuminated when send section is enabled.
10.	SEND MONITOR jack	Permits monitoring of send tone-data signal on external test equipment.
11.	SEND LOOP CUR rheostat	Adjusts send-loop current.
12.	FAILURE WHEN LIT (+) 6V (-) (2 indicators)	Either or both indicators illuminate when $\pm 6$ volts from external supply becomes shorted inside Converter.
13.	1/4 AMP SLO BLO 2 indicating fuses	Each fuse protects one side of primary power line to power supply and glows if fuse element opens.
14.	POWER/ON switch	Applies primary line power to Converter when set to ON position.

\*These METER switch positions are for maintenance functions only.



Table 2-2. Turn-on Procedures

STEP	PROCEDURE	NORMAL INDICATION	REFER TO
1.	Set POWER switch to ON	POWER (red) indicator illuminates.	Paragraph 2-4.2.
2.	Set the following switches as required for station operation (refer to table 2-1): a. FREQ OPTION  b. KEYING c. MODE d. METER	a. Position A for low band; position B for high band. b. (as required). c. Usually STBY or FDX. d. (as required).	
3.	Energize external $\pm 6$ volt power source, as required.	FAILURE WHEN LIT indicators remain extinguished.	Paragraph 2-4.2b. Fig. 3-2.

2-3.3. Signal Level Adjustment. Perform the following appropriate steps when the Converter is initially installed, when the system configuration is changed, and as a daily check.

- a. Send Neutral Input Signal.
  - (1) Apply a steady mark signal.
  - (2) Set METER switch to SEND CUR.
  - (3) Adjust SEND LOOP CUR rheostat for correct current (20 or 60 mA).
- b. Receive Neutral Output Signal.
  - (1) Set MODE switch to RCV.
  - (2) Set METER switch to RCV CUR.
  - (3) With incoming mark signal, adjust RECEIVE LOOP CUR rheostat for correct current (20 or 60 mA).
  - (4) Set MODE switch to original position.

NOTE

The OFF meter position is provided to protect the meter during shipment or enemy action. During normal operation it may be left in the position that provides the most significant information to the operator.

- c. Send Tone Data Signal.
  - (1) Set METER switch to SEND LVL.
  - (2) Set MODE switch to SEND.

WARNING

Dangerous voltages exist inside this unit which could cause loss of life or serious injury.

- (3) Raise front panel and adjust OUT LEVEL potentiometer (1A2A2R33), on component board module A2, for desired level (usually -10 dBm). (Refer to chapter 6 for raising front panel.)
- d. Receive Tone Data Signal.
  - (1) Set METER switch to RCV LVL.
  - (2) With normal received tone data signal applied, adjust RCV LEVEL potentiometer, (1A6A2R1) on component board module A6, for -10 dBm level.

2-3.4. Routine Operation. Observe the following steps while operating the associated sending and receiving devices.

- (a) When Converter is set up for half-duplex operation, the first character of a send message is normally lost due to the time required for various automatic functions to be performed. It is recommended, therefore, that transmission be started with a carriage return or blank.
- (b) When Converter is installed to provide a VOX closure to an associated radio transmitter, it is recommended that a send message be started with two carriage returns (to allow for reaction time of the radio transmitter).
- (c) If the 1/4 AMP fuse indicator lamps or the FAILURE WHEN LIT indicator lamps light, refer to paragraphs 2-4.2a and 2-4.2b, respectively.

2-3.5. Stopping. Set POWER switch to OFF position.

#### 2-4. OPERATOR'S MAINTENANCE.

2-4.1. Preventive Maintenance. Refer to chapter 4 for preventive maintenance information.

2-4.2. Emergency Maintenance. Emergency maintenance performed by the operator is confined to the replacement of blown fuses and indicator lamps.

#### WARNING

Fuse holders and fuse terminals carry dangerous voltages which could cause personal injury.

- a. If one of the 1/4 AMP fuse holders illuminates, replace the fuse with one of the correct current rating. If, immediately after replacement, a fuse blows again, notify maintenance personnel.

#### CAUTION

Failure to deenergize external  $\pm 6$  volt power supply when FAILURE WHEN LIT indicator lights could cause additional damage to the Converter.

- b. If one or both FAILURE WHEN LIT indicator lamps illuminates, deenergize the associated external  $\pm 6$ -volt supply immediately and notify maintenance personnel.

NOTE

Deenergizing Converter will have no effect, since FAILURE WHEN LIT indicator lamps and associated circuits receive power from external  $\pm$  6-volt supply.

c. If, when the POWER switch is set to ON, the POWER indicator lamp does not light but Converter functions, replace the lamp. If new lamp does not light, notify maintenance personnel.

d. If either the SEND or RECEIVE indicator lamp does not light when MODE switch is set to FDX and receive tone-data signal is active, replace bulb. If new bulb does not light, notify maintenance personnel.

## CHAPTER 3

## FUNCTIONAL DESCRIPTION

3-1. INTRODUCTION. This chapter describes the overall relationship of the major circuit areas. All circuit areas shown in the detailed block diagram are identified by name and component board assembly number to facilitate quick reference to the associated schematic diagram in chapter 5. Paragraph 3-2 outlines the general relationship of major circuits. Refer to NAVSHIPS 0967-000-0120 for general circuit descriptions.

3-2. OVERALL FUNCTIONAL DESCRIPTION. This paragraph, augmented by figure 3-1, describes the overall relationship of the major functional circuits. Each functional section is described in detail in paragraphs 3-3 through 3-11.

3-2.1. Send Input Circuits. A local dc-data signal is applied to the send input circuits which convert it to an equivalent send data on/off signal.

3-2.2. Tone Keying Circuits. The tone keying circuits convert the send-data on/off signal to a frequency-shift tone-data signal for transmission via radio/telephone to a distant converter.

3-2.3. Receive Input Circuits. A tone-data signal received from a distant converter is applied to the receive input circuits which convert it to an equivalent receive data on/off signal.

3-2.4. Loop Keying Circuits. The loop keying circuits convert the receive data on/off signal to a local dc-data signal.

3-2.5. Control Circuits. The control circuits condition the signal circuits (paragraphs 3-2.1 through 3-2.4) to operate in any one of five modes (paragraphs 3-2.5.1 through 3-2.5.5) as determined by the setting of the MODE switch.

3-2.5.1. Receive Only. When the MODE switch is set to RCV, the send section is inactive and the receive section is activated.

3-2.5.2. Send Only. When the MODE switch is set at SEND, the receive section is inactive and the send section is activated.

3-2.5.3. Automatic Half-Duplex. When the MODE switch is set to STBY (standby), the control circuits are conditioned to operate the Converter in the automatic half-duplex mode. In this mode the control circuits respond to the following three conditions:

a. When neither a send dc-data nor a receive tone-data signal is being applied at the inputs of the Converter, the control circuits disable the send-tone keying circuits and reduce the receive loop keying circuits to a standby condition.

b. When a send dc-data signal occurs first, the control circuits sense the send-data on/off signal and respond by disabling the receive circuits and enabling the tone keying circuits. When the send dc-data signal ceases, the control circuits return the Converter to the standby condition. While the send section of the Converter is in operation, the control circuits also supply a VOX closure (if used) to operate the associated radio transmitter.

c. When a receive tone-data signal occurs first, the control circuits sense it and respond by applying an inhibit to the send input circuits and removing the inhibit from the loop keying circuits. When the receive tone-data signal ceases, the control circuits return the Converter to the standby condition.

3-2.5.4. Full Duplex. When the MODE switch is set to FDX (Full Duplex), the send and receive sections are both activated.

3-2.5.5. Back-to-Back. When the MODE switch is set to S/R BTB (Send/Receive Back-to-Back), the Converter is conditioned to operate in the full-duplex mode, except the send-tone data signal is disconnected from the external line and is coupled into the receive-tone data input which is also disconnected from the external line. Also, the VOX closure (if used) is disconnected.

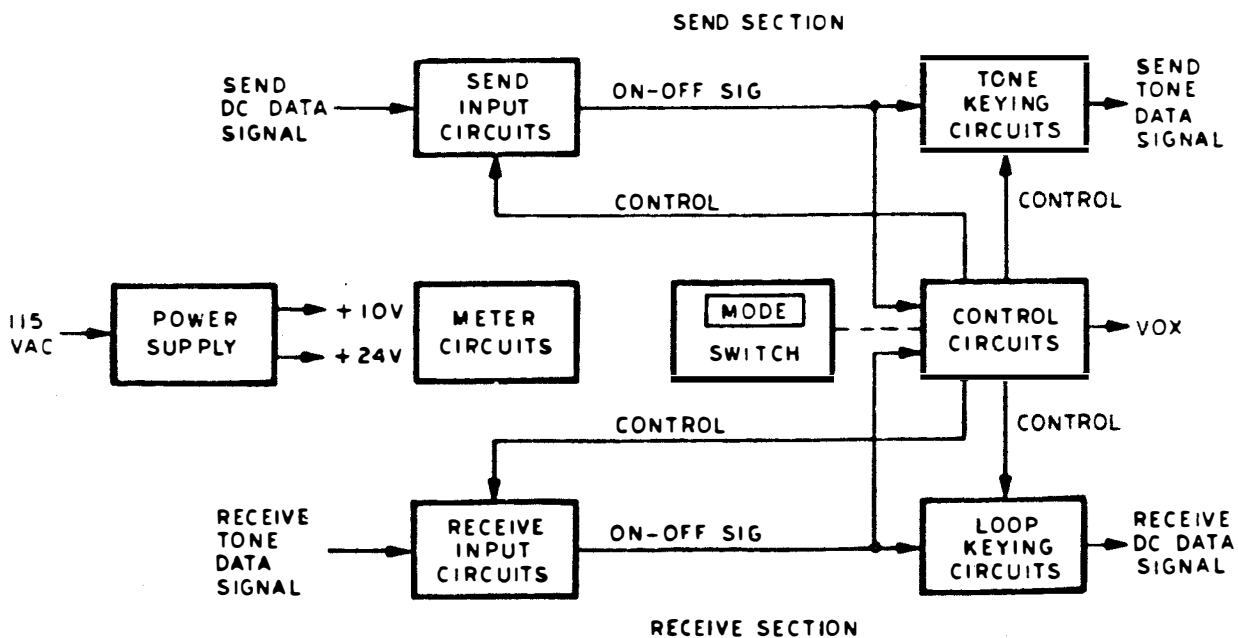

Figure 3-1. Simplified Overall Block Diagram

3-2.6. Meter Circuits. The meter circuits monitor the signal inputs of the send and receive sections, as well as the power supply output. The meter circuits also provide a means to indicate both send and receive signal bias.

3-2.7. Power Supply. The power supply circuits provide all secondary power required to operate the Converter except loop battery.

3-3. FUNCTIONAL SECTION DESCRIPTION. The following paragraphs describe each functional section in detail. All functional sections shown on the detailed block diagram (figure 3-2) are identified by name and component board assembly number to facilitate quick reference to the associated schematic diagram in chapter 5.

#### NOTE

Electronic switch A2Q1-Q2 receives operating power from an external + 6V source. Should A2Q1 or A2Q2 short, FAILURE WHEN LIT indicator lamps DS2 and DS3 light to provide visual alarm.

3-4. SEND INPUT CIRCUITS. The send-input circuits are strapped to accept either 20 mA neutral, 60 mA neutral, or low-level polar dc-data signals. The 20 mA and 60 mA signals are coupled through SEND LOOP CUR rheostat (R2) to the input of the rfi filter. Electronic switch (A2Q1-Q2) converts low-level polar signals to low-level neutral signals which are coupled to the input of the rfi filter.

Each marking element of the neutral signal at the output of the rfi filter energizes oscillator (A2T1-Q3). The output of A2Q3 is rectified by A2CR2 and shaped square by trigger (A2Q4-Q5) to produce a send-data on/off signal that corresponds to the input dc-data signal. The output of the trigger (normal sense signal) is coupled to one input of KEYING SWITCH (S2) and through inverter (A2Q6) (reverse sense signal) and emitter follower (A2Q7) to the other input of S2. SEND LOOP CUR rheostat (R2) adjusts the 20 mA or 60 mA signal current.

3-5. TONE KEYING CIRCUITS. The send-data on/off signal (normal or reverse sense, as selected by KEYING switch (S2)), is coupled into both low and high band oscillator assemblies, A3 and A4. The setting of FREQ OPTION switch (S1) determines which of the two assemblies is energized by applying +24V operating power to selected assembly.

The incoming send-data on/off signal operates electronic switch Q1 to shift the frequency of oscillator stage Q2. The output of Q2 is coupled through buffer Q3 to step bistable Q5-Q6. The bistable halves the frequency to produce a frequency-shift tone signal (low band oscillator A3: 700 Hz

mark and 500 Hz space; high band oscillator A4: 2425 Hz mark and 1575 Hz space). Potentiometers, 1A3A2R4 and 1A3A2R8 (or 1A4A2R4 and 1A4A2R8) adjust the space and mark tone frequencies respectively. It should be noted that while R4 is the mark potentiometer, its adjustment affects the timing and amplitude of the space tone. Likewise, adjustment of R8 (space potentiometer) adjusts the timing and amplitude of the mark tone. The tone signal is coupled through emitter follower Q7 and pass filter FL1 to FREQ OPTION switch S1.

The high band and low band tone signal (as selected by S1) is connected to amplifier A2Q8-Q9 via OUT LVL control 1A2A2R33. Amplifier A2Q8-Q9 raises the send-tone signal level to a maximum of +10 dBm. The output of the amplifier is matched to the load impedance by output transformer A2T2. Selection of either 600 or 50 ohm output impedance is provided by 600/50 toggle switch A2S1. The output is then connected to either the external send line terminals or the RCV input by MODE switch S3. The output tone signal may be monitored on external equipment via SEND MONITOR jack J1.

#### NOTE

MODE switch S3, when set to any position except S/R BTB, connects the send tone-data signal to the external line. When set to S/R BTB (back-to-back), it connects the send-tone data signal through a 10 dB pad R12-R14 to the input network in the receive input circuits.

3-6. RECEIVE INPUT CIRCUITS. The receive-tone data signal is coupled through part of MODE switch S3 to the input network. The input network matches the external line to the inputs of the low and high band pass filters. The input network also provides automatic gain control circuits and a tone signal output to the meter circuits.

Part of FREQ OPTION switch S1 selects the pin 9 output of either the low or high band filter and connects it to the limiter network. The FREQ OPTION switch also connects the amplified outputs (pin 6) of both filters to rectifier A5CR13-CR16. When a receive vf signal is present, the resultant voltage developed at the rectifier is coupled through amplifier A5Q13-Q14 to the control circuits (paragraph 3-9). When noise only is present at the vf input, the outputs of the two filters are of about equal level and, therefore, cancelled at the rectifier, providing a guard-band function.

The tone signal from pin 9 of the selected pass filter is coupled through limiter A6Q4-Q8 to either the low or high band phase shifter, as selected by the FREQ OPTION switch. The output of A6Q4-Q8 is also coupled through A6Q9 (reverse sense) to one side of KEYING switch S2 and through A6Q10 (normal sense) to the other side of switch S2. The low or high band



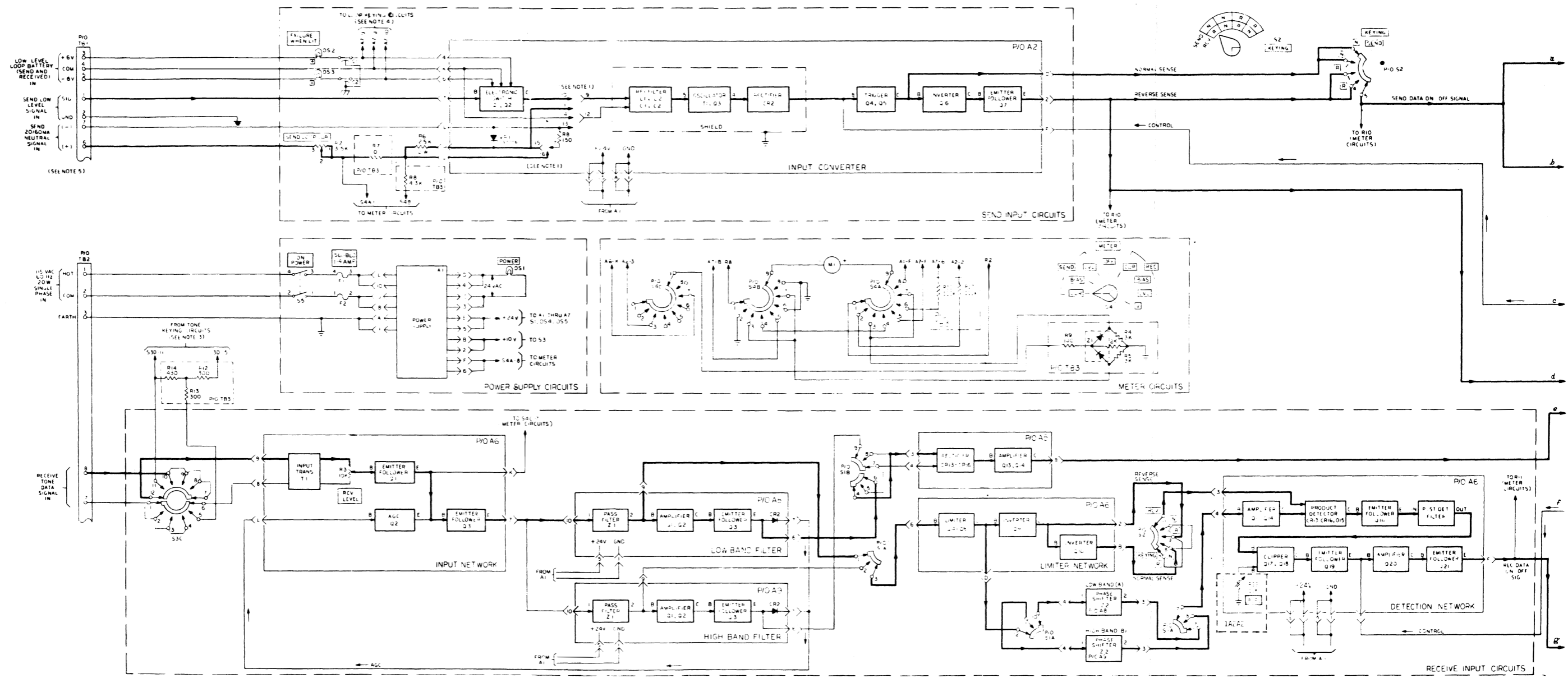

Figure 3-2. Detailed Overall Block Diagram (Sheet 1 of 2)

NOTES:  
 1. COMPONENT BOARD A2 IS STRAPPED TO ACCEPT ONE OF THREE LOOP SIGNAL MODES AS FOLLOWS;

MODE	STRAPS
LOW LEVEL POLAR	9-10, 12-14
20MA NEUTRAL	9-11, 12-13
60MA NEUTRAL	9-11, 12-13 15-16, 15-17

2. COMPONENT BOARD A7 IS STRAPPED TO PRODUCE ONE OF THREE OUTPUT LOOP SIGNAL MODES AS FOLLOWS;

MODE	STRAPS
LOW LEVEL POLAR	11-13, 14-16 7-8, 4-6, 2-3
HIGH LEVEL CURRENT	9-10, 4-5, 1-3, *7-9
HIGH LEVEL VOLTAGE	7-8, 4-6 11-12, 14-15, 2-3

3. WHEN MODE SWITCH S3 IS SET TO S/R BTB (BACK-TO-BACK) THE SEND TONE DATA SIGNAL CONNECTS THRU A 100B PAD TO THE RECEIVE INPUT NETWORK. EXTERNAL TONE LINES ARE DISCONNECTED.

4. ELECTRONIC SWITCHES Q1, Q2 ON COMPONENT BOARD A2 AND Q8-Q11 ON COMPONENT BOARD A7 RECEIVE OPERATING POWER FROM AN EXTERNAL POWER SUPPLY CONNECTED TO TB1. FAILURE WHEN LIT LAMPS LIGHT IF EITHER ELECTRONIC SWITCH SHORTS.

5. EXTERNAL LOOP POWER SUPPLIES ARE REQUIRED. LOW LEVEL VOLTAGES ARE OBTAINED FROM EXTERNAL POWER SUPPLY REFERRED TO IN NOTE 4.

6. ALL SWITCH WAFERS ARE SHOWN AS VIEWED FROM REAR WITH THEIR FRONT PANEL KNOBS SET TO FULL COUNTER CLOCKWISE POSITION.

\* STRAP 7-9 IS USED ONLY WHEN THE SYSTEM USES CONSTANT CURRENT REGULATORS SUCH AS (LC-3). THIS ACTION DELETES THE CURRENT LIMITING FUNCTION OF THE CV-2460/SGC RECEIVE OUTPUT.

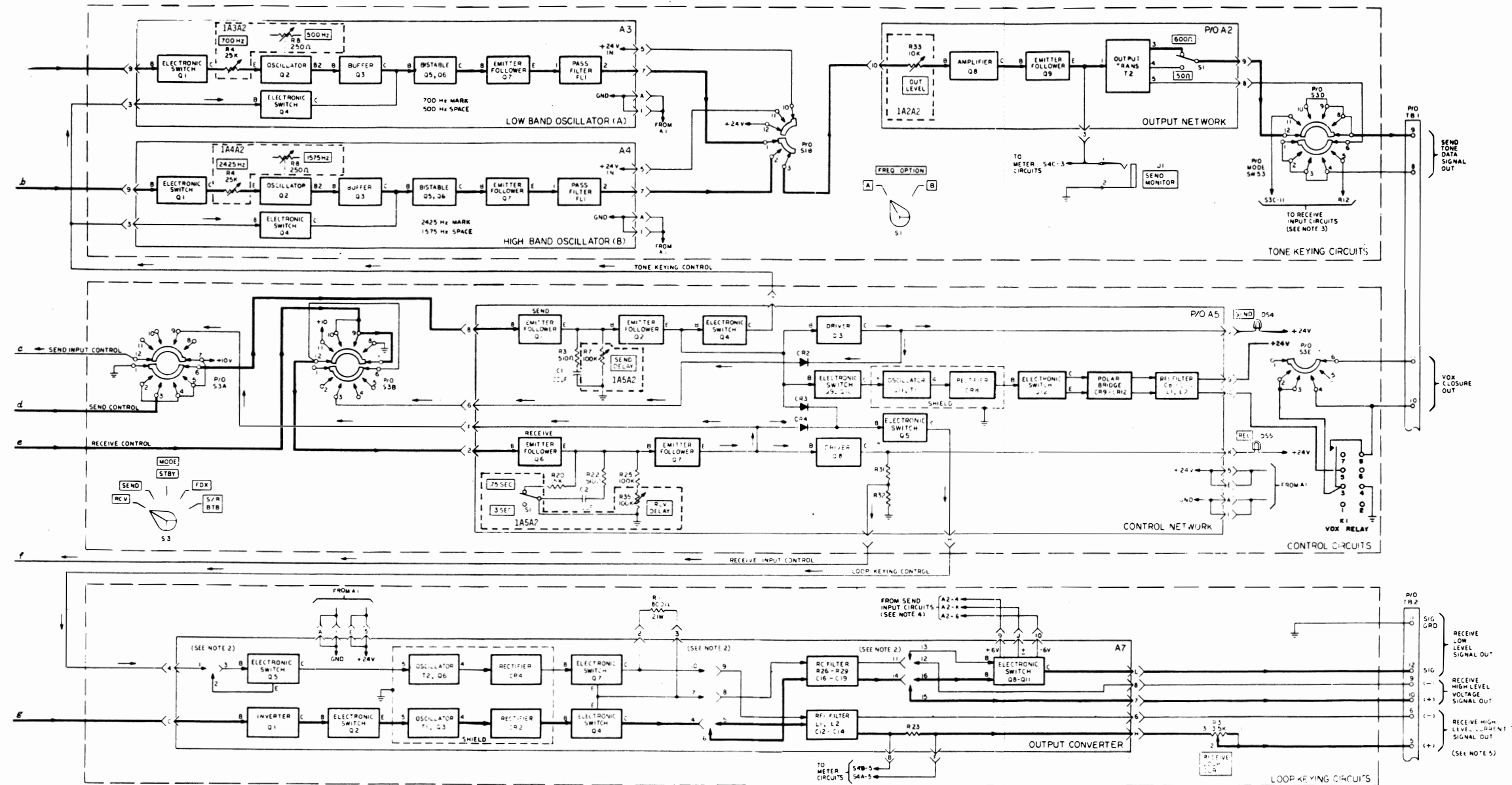

Figure 3-2. Detailed Overall Block Diagram (Sheet 2 of 2)

phase shifted signal, as selected by FREQ OPTION switch S1, is coupled through amplifier A6Q11-Q14, which shapes the signal square, to one input of the product detector. The normal or reverse sense signal, as selected by KEYING switch S2, is coupled to the other input of the product detector.

The product detector combines the two out-of-phase signals to produce a pulse train. Since the phase shifter shifts the mark component more than the space component, the output of the product detector is a pulse train that consists of relatively wide positive pulses during a space condition and relatively narrow positive pulses during mark condition. (The function of the product detector is explained in detail in paragraph 3-7.) The pulse train is coupled through emitter follower A6Q16 to the post-detection filter. The filter averages the positive pulse widths to produce a 2-level output signal. The narrow positive pulses average to a relatively low level, corresponding to a mark, and the wide positive pulses average to a relatively high level, corresponding to a space. The 2-level signal is then coupled through clipper A6Q17-Q18, which converts it to an on/off signal that corresponds to the receive tone data signal. The on/off signal is coupled through emitter follower A6Q19, amplifier A6Q20, and emitter follower A6Q21 to the input of the loop keying circuits. RCV LEVEL potentiometer 1A6A2R1 adjusts the amplitude of the incoming tone signal and BIAS potentiometer 1A6A2R33 adjusts the receive data on/off signal for minimum bias distortion.

#### NOTE

MODE switch S3, when set to any position except S/R BTB, connects the external tone line to the input network. When set to S/R BTB (back-to-back), it connects the send-tone data signal from the output network of the tone keying circuits, through 10 dB pad R12-R14, to the input network.

3-7. PRODUCT DETECTOR. The tone signal from limiter Q4-Q8 is coupled through inverters Q9 and Q10 and switch S2 to one input of the product detector (A)(figure 3-3). The same tone from Q4-Q8 is also coupled through S1, phase shifter Z2, and amplifier-squarer Q11-Q14 to the other input (B). Both are the same amplitude, 50 percent duty cycle, square waves, differing from each other only by the phase shift introduced by Z2. In the conducting condition, the collectors of Q9 (or Q10) and Q14 are essentially grounded. Nonconducting, they are at the battery potential (+). The product detector proper consists of base steering diodes CR13 and CR14, emitter steering diodes CR15 and CR16, transistor Q15, and associated resistors R48, R49 and R50.

Current will flow in the collector of Q15 only when the emitter is grounded and the base is sufficiently positive. If, for example, the signals at the collectors of Q10 and Q14 were 180 degrees out of phase, this

condition would always be satisfied. When Q10 is at ground, the emitter of Q15 would also be at ground via CR16. At the same time, the base of Q15 would be switched to a positive potential through CR14 by the collector of Q14 going positive. In the reverse case, the emitter would be grounded by Q14-CR15 and the base made positive by Q10-CR13. In this particular example, the output of Q15 would always be essentially zero, since current flows over the entire 360 degree cycle. In this actual case, the outputs of Q10 and Q14 are not 180 degrees out of phase, but 135 degrees for an incoming mark signal and 45 degrees for a space signal. Current will then flow in the collector of Q15 only when one collector, Q10 (Q9) or Q14, is high and the other low. When they are both high or both low, Q15 cannot conduct.

The result of applying two similar, but out-of-phase, square wave tone signals to the detector is a pulse train at the collector of A6Q15. The positive pulses will be relatively wide when the phase shift is 45 degrees and relatively narrow when the phase shift is 135 degrees. (Figure 5-15 shows the waveforms for both inputs and the resultant output of the product detector for each of four situations.) Note that a normal sense mark tone has the same frequency as a reverse sense space tone and that the normal space tone is of the same frequency as the reverse sense mark tone. Also, an additional 180 degree phase shift is introduced in one input to the bridge when the KEYING switch is set to RVS (reverse sense), because the output inverter A6Q9 is used instead of A6Q10. In summary, the output of product detector A6Q15 consists of a train of positive pulses that are wide during a space condition and narrow during a mark condition. The pulse widths are then averaged by the post-detection filter (paragraph 3-6).

3-8. LOOP KEYING CIRCUITS. During each of its mark conditions, the receive data on/off signal from the receive input circuits is inverted by amplifier A7Q1 to operate electronic switch A7Q2 to energize oscillator A7T1-Q3 (figure 3-2). The output of the oscillator is rectified by A7CR2 to operate electronic switch A7Q4 to key the receive loop. The output of the loop keying circuits is strapped to key either a high-level current, high-level voltage, or low-level polar loop. The high-level current loop is keyed by A7Q4 via electronic switch A7Q7 (closed), the rfi filter, and RECEIVE LOOP CUR rheostat R2. Electronic switch A7Q7 is held closed by the control circuits except during half-duplex operation with no send or receive signals applied. While A7Q7 is open, R1 is placed in series with the high-level loop to reduce current to 60 percent of normal. This function prevents external equipment from overheating during steady mark standby condition. The high-level voltage loop is keyed by A7Q4 via the RC filter. For low-level polar operation, A7Q4 keys electronic switch A7Q8-Q11 via the RC filter, and the electronic switch keys the low-level polar loop. RECEIVE LOOP CUR rheostat R2 adjusts the high-level current rate.

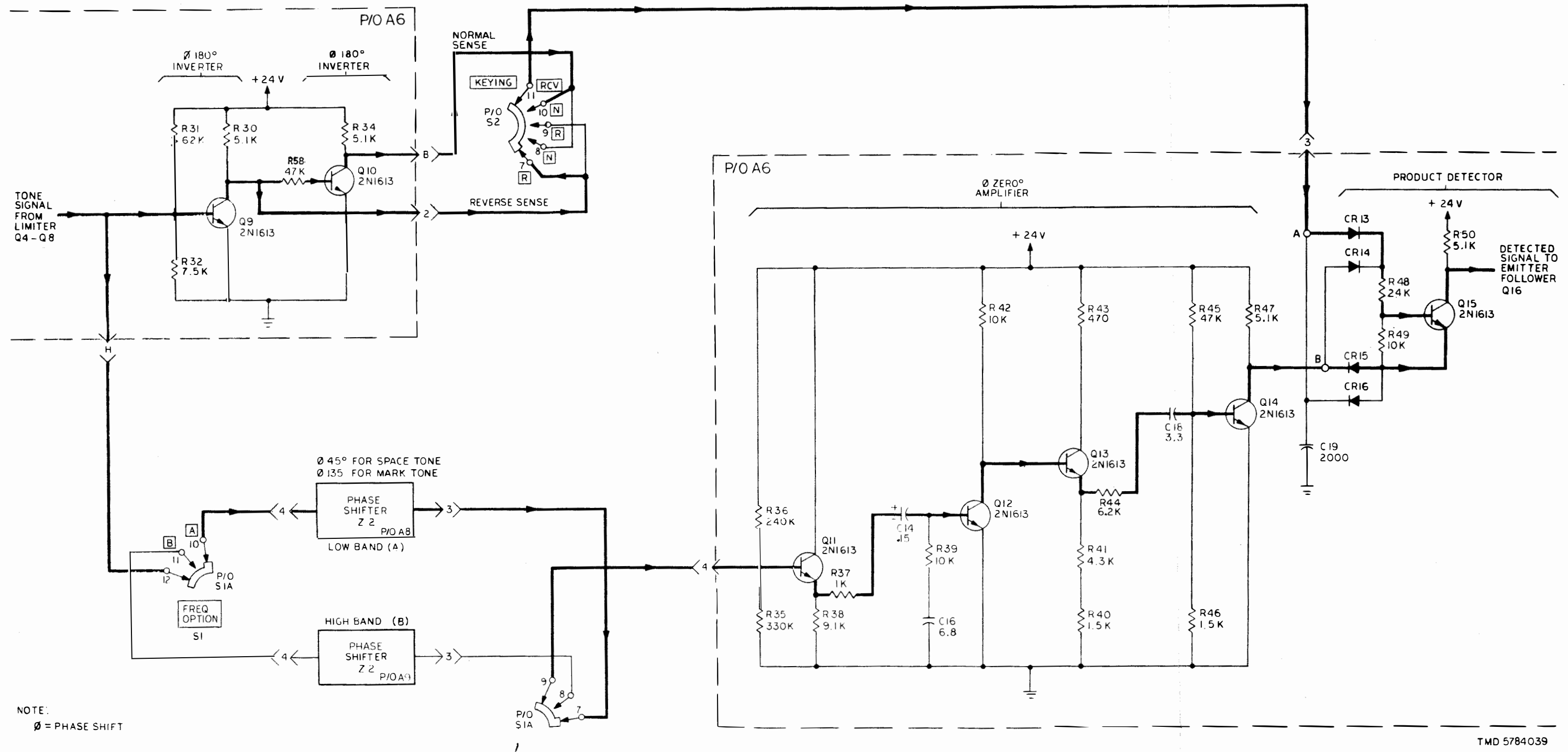

TMD 5784039

Figure 3-3. Frequency Discriminator Circuits

## NOTE

Electronic switch A7Q8-Q11 receives operating power from the same external +6V source as does electronic switch A2Q1-Q2 in the send input circuits. Should either electronic switch short, FAILURE WHEN LIT indicator lamp DS2 and DS3 light to provide visual alarm.

3-9. CONTROL CIRCUITS. Each of the five settings of MODE switch S3 condition the control circuits to operate the Converter in one of five modes: receive only, send only, half-duplex, full duplex, and back-to-back (figure 3-2). Depending on the mode setting of S3, the control circuits disable and enable the send input circuits, tone keying circuits, receive input circuits, and loop keying circuits in the various combinations outlined in table 3-1.

3-9.1. Control Network. The condition of the tone keying, receive input, loop keying circuits is determined by the voltage levels (high or low) applied to the bases of emitter-followers A5Q1 (refer to paragraph 3-9.1a) and A5Q6 (refer to paragraph 3-9.1b).

a. When a high is applied to A5Q1, capacitor A5C1 charges to a level high enough to saturate A5Q2, thus producing a high at the emitter of A5Q2. When the high is removed from A5Q1, the high at the emitter of A5Q2 remains for three seconds due to the time constant of A5C1-R3-R7. Emitter followers A5Q6 and A5Q7 function in the same way, except that the time constant is switch selectable for either three seconds or three fourths second.

When a high is applied to the base of A5Q1, the resultant high at the emitter of A5Q2 saturates A5Q4, A5Q3, A5Q9-10, and A5Q5. The resultant low at the collector of A5Q4 cuts off electronic switch A3(A4)Q4 in the low- or high-band oscillator, thus enabling the tone keying circuits. Driver A5Q3 lights SEND indicator lamp DS4. Electronic switch A5Q9-Q10 energizes oscillator A5Q11, the rectified output of which closes electronic switch A5Q12, energizing K1, providing a VOX closure to an external radio transmitter, if any. The low at the collector of A5Q5 saturates electronic switch A7Q5 in the loop keying circuits.

When saturated, A7Q5 energizes oscillator A7Q2, the rectified output of which closes electronic switch A7Q7, thus shorting out R1 and increasing the loop current from standby to full. When a low is applied to the base of A5Q1, the resultant low at the collector of A5Q2 cuts off A5Q4, A5Q3, and A5Q9-Q10 and A5Q5. The resultant high at the collector of A5Q4 saturates A3(A4)Q4 in the low or high band oscillator.

When saturated, A3(A4)Q4 grounds the input to bistable A3(A4)Q5-Q6, thus disabling the tone keying circuits. When cut-off, driver A5Q3 does not light SEND indicator lamp (DS4), and A5Q9-Q10 do not initiate a VOX closure. In summary: a high applied to A5Q1 enables the tone keying

circuits, lights the SEND indicator lamp, provides a VOX closure, and enables the loop keying circuits. A low applied to A5Q1 disables the tone keying circuits, turns off the SEND indicator lamp, and opens the VOX closure.

b. When a high is applied to the base of A5Q6, the resultant high at the emitter of A5Q7 saturates A5Q8 and A5Q5. When saturated, A5Q8 lights RECEIVE indicator lamp (DS5) and develops a low at the junction of R31-R32. That low enables amplifier A6Q20 in the receive input circuits. Electronic switch A5Q5, when saturated, enables the loop keying circuits as described in paragraph 3-8. When a low is applied to the base of A5Q6, the resultant low at the emitter of A5Q7 cuts off A5Q8 and A5Q5. Driver A5Q8, therefore, does not light RECEIVE indicator lamp (DS5) and develops a high at the junction of R31-R32. That high saturates amplifier A6Q20 in the receive input circuits, thus disabling them. In summary: a high applied to A5Q6 enables the loop keying and receive input circuits and lights the RECEIVE indicator lamp. A low applied to A5Q6 disables the receive input circuits, does not light the RECEIVE indicator lamp, and does not enable the loop keying circuits.

Table 3-1. Control Circuit Functions

MODE SWITCH (S3) SETTING	SEND SECTION		RECEIVE SECTION	
	SEND INPUT CIRCUITS	tone KEYING CIRCUITS	RECEIVE INPUT CIRCUITS	LOOP KEYING CIRCUITS
RCV (receive only)	Disabled	Disabled	Enabled	Enabled
SEND (send only)	Enabled	Enabled	Disabled	Enabled*
STBY (half-duplex): Send dc-data and receive tone-data signals inactive	Enabled	Disabled	Disabled	Disabled
Send dc-data signal active	Enabled	Enabled	Disabled	Enabled*
Receive tone-data signal active	Disabled	Disabled	Enabled	Enabled
FDX (full duplex)	Enabled	Enabled	Enabled	Enabled
S/R BTB (back-to-back)	Enabled	Enabled	Enabled	Enabled

\*Loop keying circuits are enabled when send section is enabled when a 2-wire teleprinter is used in loop. In the absence of traffic, the receive loop keying current is automatically reduced to 60 percent of normal.

3-9.2. Receive Only. With MODE switch set to RCV, S3A applies a low (ground) to A5Q1, thus disabling the tone keying circuits, extinguishing the SEND indicator lamp, and opening the VOX closure. Switch S3A also applies a high (+10 volts) to disable the send input circuits by locking them in the steady mark condition. Switch S3B applies a high to A5Q6, thus lighting the RECEIVE indicator lamp and enabling the receive input and loop keying circuits. The high applied to A5Q6 via S3B is obtained by rectifying the receive tone data signal. The tone signal is rectified by A5CR13-CR16, shown in figure 3-2, in the receive input circuits. When the receive signal is not active, the base of A5Q6 goes low to disable the entire receive section. This prevents noise from keying the receive loop.

3-9.3. Send Only. With MODE switch S3 set to SEND, S3A applies a high (+10 volts) to A5Q1, thus enabling the tone keying circuits, lighting the SEND indicator lamp, closing the VOX closure, and enabling the loop keying circuits. Switch S3A also opens the control line to the send input circuits, thus enabling them. Switch S3B applies a low (ground) to A5Q6, thus disabling the receive input circuits and extinguishing the RECEIVE indicator lamp.

3-9.4. Full Duplex. With MODE switch S3 set to FDX, S3A applies a high (+10 volts) to A5Q1, thus enabling the tone keying circuits and lighting the SEND indicator lamp. (In the FDX position, S3E makes the VOX closure.) Switch S3A also opens the control line to send input circuits, thus enabling them. Switch S3B opens the base of A5Q6, which may be considered as applying a high. This enables the receive input and loop keying circuits and lights the RECEIVE indicator lamp.

3-9.5. Back-to-Back. With MODE switch S3 set to S/R BTB, the control circuits perform the same functions as described in paragraph 3-9.4. The external send and receive tone-data lines are opened, and the send output connects through 10 dB pad R12-R14 to the receive input. Also, the VOX closure is disconnected from its external line.

3-9.6. Half-Duplex. With MODE switch S3 set to STBY, S3A applies the inverse output of the send input circuits to A5Q1. Switch S3B applies the rectified receive tone signal to A5Q6. In this mode, the control circuits perform three different functions under three different conditions: no signals active (paragraph 3-9.6a), send signal active (paragraph 3-9.6b), and receive signal active (paragraph 3-9.6c).

a. No Signals Active. When neither the send nor receive signal is active, both A5Q1 and A5Q6 have lows applied to their bases. This disables the tone keying, receive input, and loop keying circuits. Also the SEND and RECEIVE indicator lamps are out and the VOX closure is open. The Converter is in the standby condition.



b. Send Signal Active. If the send signal becomes active first, the space elements will apply a high to A5Q1, thus enabling the tone keying circuits, lighting the SEND indicator lamp, closing the VOX closure, and enabling the loop keying circuits. Also, the low at the collector of A5Q3 is applied via a diode and S3B to the base of A5Q6. Should the receive signal become active, it will have no effect on A5Q6, and the receive input circuits will remain disabled. Should the send signal cease, the tone keying circuits will be disabled three seconds later (the discharge time of A5C1).

c. Receive Signal Active. If the receive signal becomes active first, it applies a high to A5Q6, thus enabling the loop keying and receive input circuits and lighting the REC indicator lamp. Also, the high at the collector of A5Q7 is applied via S3A to the send input circuits, thus disabling them.

3-10. METER CIRCUITS (Figure 3-1). The meter circuits consist essentially of METER switch S4, which selects any one of the seven test points, described below, to be monitored on meter M1.

a. Send Current. When set to SEND CUR, S4 connects the potential developed across R7 (send input circuits) to the meter.

b. Send Bias. When set to SEND BIAS, S4 connects the on-off data signal from the output of the send input circuits through dropping resistor R10 to the meter.

c. Send Level. When set to SEND LVL, S4 connects the send tone-data signal from Q9 (tone keying circuits) through the meter rectifier to ground. The output of the rectifier is applied across the meter movement.

d. Receive Current. When set to RCV CUR, S4 connects the potential developed across R23 (loop keying circuits) to the meter.

e. Receive Bias. When set to RCV BIAS, S4 connects the on-off data signal from the output of the receive input circuits through dropping resistor R11 to the meter.

f. Receive Level. When set to RCV LVL, S4 connects the receive tone-data signal from Q1 (receive input circuits) through the meter rectifier to a ground. The output of the rectifier is applied across the meter movement.

g. Voltage. When set to V, S4 connects the potential developed across voltage divider R4-R9 (not shown) inside the power supply to the meter. The meter then monitors +24 volts secondary power.

3-11. POWER SUPPLY. The primary power (115 Vac) connects through TB3, POWER ON switch (S5), and two 1/4 ampere fuses (F1 and F2) to component module A1 (figure 3-1). The component module mounts the stepdown transformer, bridge rectifier, smoothing filter, and voltage and current regulators for the +10 and +24 volts secondary power. The POWER indicator lamp (DS2) connects across the secondary of the transformer. The schematic diagram for assembly A1 is shown in Chapter 5.

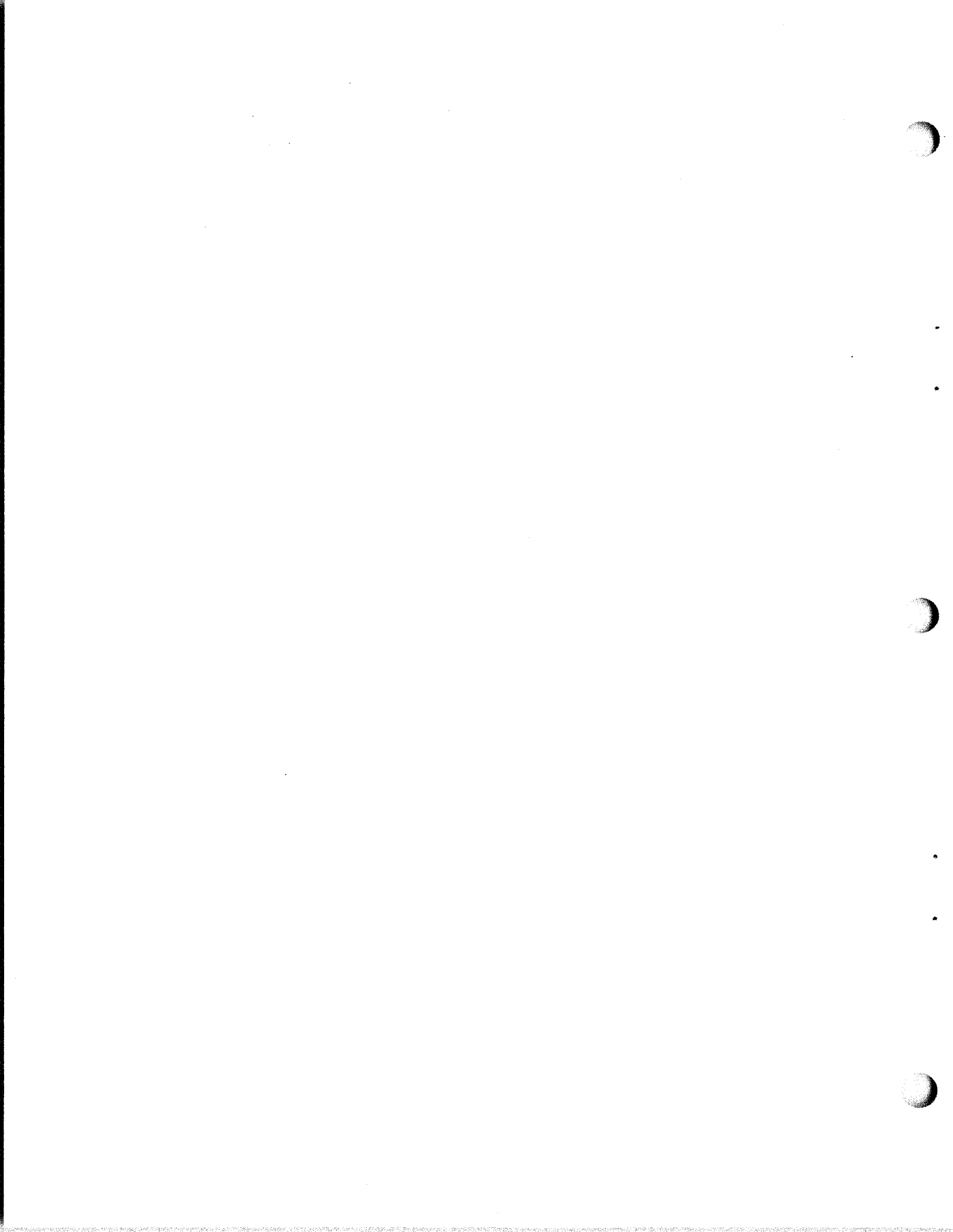

## CHAPTER 4

## SCHEDULED MAINTENANCE

4-1. INTRODUCTION. Scheduled maintenance is that maintenance required to be performed on the equipment at regular scheduled intervals, whether or not the equipment is in use. The purpose of scheduled or preventive maintenance is to keep the equipment in good working order and to ensure proper performance when the equipment is needed. Scheduled maintenance is performed at the Intermediate Level.

WARNING

Dangerous voltages exist in this unit which could cause loss of life or serious injury.

## NOTE

The scheduled maintenance instructions in this manual are intended to duplicate those furnished in the Planned Maintenance System (PMS). In case of conflicts, the PMS documentation takes precedence. Such conflicts should be reported immediately in accordance with maintenance procedures for this manual.

## 4-2. PREVENTIVE MAINTENANCE.

4-2.1. Operator's Procedure. Perform the following, each day, during normal operation.

a. Clean front panel (and shelf enclosure, if exposed) with a soft, lint-free cloth. Dampen with Cleaning Compound (MIL-C-18718) as required; wipe dry with a clean cloth.

b. Perform the procedure outlined in table 2-2.

c. During performance of the procedure outlined in table 2-2, and during normal operation, check that all controls and switches operate smoothly without binding. All knobs should be secure on their shafts and should align properly with panel markings.

d. Check that the cabinet grounding strap is secure and that its connections are not corroded.

4-2.2. Technician's Procedure. Every 90 days, perform the initial checks and adjustments (refer to chapter 8) and the adjustment procedure (refer to chapter 6), correcting any misadjustments and malfunctions observed. Refer to chapter 5 for troubleshooting procedures, and refer to figures 5-1 through 5-20 as necessary; repair by replacing faulty part as required.

4-3. SCHEDULED MAINTENANCE. The scheduled maintenance shall be conducted in the following manner every 90 days.

- a. Perform the initial checks and adjustments (chapter 8),
- b. Perform adjustment procedures (chapter 6),

4-4. SCHEDULED PERFORMANCE TESTS. Checkout of the Converter may be accomplished by using procedures set forth in chapters 2 and 8. Troubleshooting of abnormal indications are covered in chapter 5.

## CHAPTER 5

## TROUBLESHOOTING

5-1. INTRODUCTION. This chapter contains information to aid in quickly and efficiently determining the cause of equipment malfunction. The information is given in order of overall troubleshooting technique, operational data (functional and logical), and troubleshooting data.

## 5-2. LOGICAL TROUBLESHOOTING.

5-2.1. Symptom Recognition. This is the first step in the troubleshooting procedure and is based on a complete knowledge and understanding of equipment operating characteristics. All equipment troubles are not necessarily the direct result of component failure. Therefore, a trouble in an equipment is not always easy to recognize, since all conditions of less than peak performance are not always apparent. This type of equipment trouble is usually discovered while accomplishing preventive maintenance procedures. It is important that the "not so apparent" troubles, as well as the apparent troubles, be recognized and corrected.

5-2.2. Symptom Elaboration. After an equipment trouble has been "recognized", all the available aids designed into the equipment should be used to elaborate on the original trouble symptom. Use of front panel controls and other built-in indicating or testing aids should provide better identification of the original trouble symptoms. Also, checking or otherwise manipulating the operating controls may eliminate the trouble.

5-2.3. Listing Probable Faulty Function. The next step in logical troubleshooting is to formulate a number of "logical choices" as to the cause and likely location (functional section) of the trouble. The "logical choices" are mental decisions which are based on knowledge of the equipment operation, a full identification of the trouble symptom, and information contained in this manual. The overall functional description and its associated block diagram should be referred to when selecting possible faulty functional sections.

5-2.4. Localizing the Faulty Function. For the greatest efficiency in localizing trouble, the functional sections which have been selected by the "logical choice" method should be tested in an order that will require the least time. This requires a mental selection to determine which section to test first. The selection should be based on a further extension of the "logical choice" method. If the tests do not prove that functional section to be at fault, the next section should be tested, and so on until the faulty functional section is located. As aids in this process, this manual contains a functional description and a servicing block diagram for each functional section. Waveforms are included at significant check points on

servicing block diagrams to aid in isolating the faulty section. Also, where applicable, test data (such as information on control settings, critical adjustments, and required test equipment) are supplied to augment the functional description and servicing block diagram for each functional section.

5-2.5. Localizing Trouble to the Circuit. After the faulty functional section has been isolated, it is often necessary to make additional "logical choices" as to which circuit or group of circuits (within the functional section) is at fault. Servicing block diagrams for each functional section provide the signal flow and test location information needed to bracket and then isolate the faulty circuit.

5-2.6. Failure Analysis. After the trouble (faulty component, etc.) has been located (but prior to performing corrective action), the procedures followed up to this point should be reviewed to determine exactly why the fault affected the equipment in the manner it did. This review is usually necessary to make certain that the fault discovered is actually the cause of the malfunction, and not just the result of the malfunction.

### 5-3. TROUBLESHOOTING PROCEDURE.

First, become familiar with the Converter's operation (chapter 2) and its functional description (chapter 3). Then, use table 5-1 as a general guide to locate and isolate the trouble. Troubleshooting should be performed with the unit's MODE switch set to S/R BTB with a sending and receiving device patched into the system as shown in figure 5-1. This will aid in isolating any troubles to the Converter. When necessary, the troubleshooting may be done with the Converter externally patched to another Converter and operated in the full- or half-duplex configuration.

When the Converter is suspected of malfunction, use the test equipment listed in table 2-1 and follow the procedures listed in table 5-1. Before starting the fault isolation procedures, check the following:

a. Check that the Converter is being used correctly, in accordance with the instructions in chapter 2.

#### WARNING

Dangerous voltages exist inside this unit which could cause loss of life or serious injury.

b. Open the front panel and visually inspect the rear of the panel, looking for damaged switches and wiring.

c. Set POWER switch to ON. Set METER switch to V. Meter pointer should deflect to correct indication (VOLT mark on meter).

5-3.1. Fault Isolation. Perform the procedures listed in table 5-1 based on the fault symptom(s) determined during operation or Loop Testing. After a fault has been isolated to a particular board, use the test equipment listed in table 1-2, the functional descriptions from chapter 3, and the schematic diagrams (chapter 5) to isolate the fault to a particular component or group of components. Use the board extender to operate the faulty board in the circuit while troubleshooting.

5-3.2. Diagrams. Figures 5-1 through 5-19 are schematic diagrams and parts location drawings for the Converter. Use the schematic diagrams along with standard troubleshooting procedures and the test equipment listed in table 1-2 to locate defective parts within the Converter or on the printed circuit boards. The schematic diagrams also contain wave forms and voltages for the various test points. Figure 5-20 is the wiring diagram for the Converter.



Table 5-1. Fault Isolation Procedures

STEP	SYMPTOM	ISOLATION PROCEDURE	PROBABLE CAUSE	CORRECTIVE ACTION
1.	POWER lamp does not light, fuse not blown	Remove indicator lamp from lampholder and check for open filament using multimeter. If lamp tests OK, go to next step.	Lamp burned out	Replace defective indicator lamp.
2.	POWER lamp does not light, fuse not blown	Turn off circuit breaker or otherwise disconnect Converter from power source. Open front panel (see chapter 6) and check wiring to POWER switch. If wiring is OK, check continuity of POWER switch in ON position using multimeter. If switch tests OK, check power source.	Faulty POWER switch	Repair wiring to, or replace POWER switch.
3.	Fuse holder glows (fuse blown)	<p>a. Turn off POWER switch and open front panel (see chapter 6). Pull out until pins are disengaged, but do not remove PCB's A2 thru A9. Replace blown fuse and set POWER switch to ON. Check for blown fuse.</p> <p>b. Set POWER switch to OFF. Reinstall PCB's A2 thru A9, one at a time, setting POWER switch to ON after inserting</p>	Defective power supply or other module	<p>a. If fuse is blown, replace defective power supply. If fuse is not blown, go to step 3b.</p> <p>b. When fuse blows after inserting a module, remove that module and replace with a new one.*</p>

Table 5-1. Fault Isolation Procedures-continued

STEP	SYMPTOM	ISOLATION PROCEDURE	PROBABLE CAUSE	CORRECTIVE ACTION
3. (Cont)		each module. Check fuses after inserting each module, if not blown, set POWER switch to off and insert next module.		Continue isolation procedure to assure that other modules are not defective. To troubleshoot PCB's, refer to para. 5-3.1.
4.	FAILURE WHEN LIT indicators light	<p>Open front panel (see chapter 6).</p> <p>a. Pull out until pins are disengaged but do not remove board A7 and check FAILURE WHEN LIT indicator lamps.</p> <p>b. Pull out until pins are disengaged but do not remove PCB A2 and check FAILURE WHEN LIT indicator lamps.</p>	Defective external $\pm 6$ volt power source or PCB's A2 or A7.	<p>a. If both indicators extinguish, remove and replace board A7.* If either or both indicators are lit, go to step 4b.</p> <p>b. If both indicators are extinguished, remove and replace board A2.*</p> <p>If either or both indicators are lit, troubleshoot external <math>\pm 6</math> volt power source in accordance with equipment technical manuals. To troubleshoot PCB's, refer to para. 5-3.1.</p>
5.	Send/Receive malfunction:	Set POWER switch to ON; set MODE switch to S/R BTB; and set FREQ OPTION switch to A. Apply a steady mark signal to send input.		

Table 5-1. Fault Isolation Procedures-continued

STEP	SYMPTOM	ISOLATION PROCEDURE	PROBABLE CAUSE	CORRECTIVE ACTION
5. (Cont)	a. Will not send or receive.	a. Converter will not send or receive.	a. Defective PCB A5.	a. Remove and replace defective board A5.
	b. Will not send but will receive	b. Set METER switch to SEND LVL and observe output level (should be -10 dBm). If no output, set FREQ OPTION switch to B.	b. Defective PCB A2.	b. If no output in either A or B position, remove and replace board A2.*
		b.(1) Set FREQ OPTION switch to A. Alternately set switch to normal and KEYING reverse sense positions while observing front panel meter. Meter should indicate slight variation in vf level from one switch position to another.	(1) Defective PCB A2, A3, or A4.	(1) If variation occurs in step b(1) but not in b(2), remove and replace PCB A4. If variation occurs in step b(2) but not in b(1), remove and replace PCB A3. If no variation occurs in b(1) or b(2), remove and replace PCB A2.*
		(2) Set FREQ OPTION switch to B and alternate KEYING switch. Observe meter for variations in output level.		
	c. Will not receive but will send.	c.(1) Set METER switch to RCV LVL. With a SEND OUT LEVEL of -10 dBm, RCV LVL should indicate approximately -20 dBm (if RCV LVL is	(1) Defective PCB A6, A7, A8, or A9.	(1) If meter reading is not obtained, remove and replace board A6.

Table 5-1. Fault Isolation Procedures-continued

STEP	SYMPTOM	ISOLATION PROCEDURE	PROBABLE CAUSE	CORRECTIVE ACTION
5. (Cont)		<p>adjusted in accordance with chapter 8). Set MODE switch to FDX and patch vf SEND to vf RCV input. Meter should read -10 dBm.</p> <p>(2) Patch test signal to send input. Set METER switch to RCV BIAS. Meter should indicate BIAS mark. If correct indication is obtained, go to step c(4). If correct indication is obtained, go to step c(3).</p> <p>(3) Set FREQ OPTION switch to B.</p> <p>(4) Set FREQ OPTION switch to B.</p>		<p>(2) (See below.)</p> <p>(3) If correct indication is obtained, remove and replace board A8. If incorrect indication is obtained, remove and replace board A6.</p> <p>(4) If correct indication is obtained, remove and replace board A7.* If incorrect indication is obtained, remove and replace board A9.</p>

\*When replacing board A2 or A7, assure strapping on replacement board is the same on the board being removed (see chapter 8).

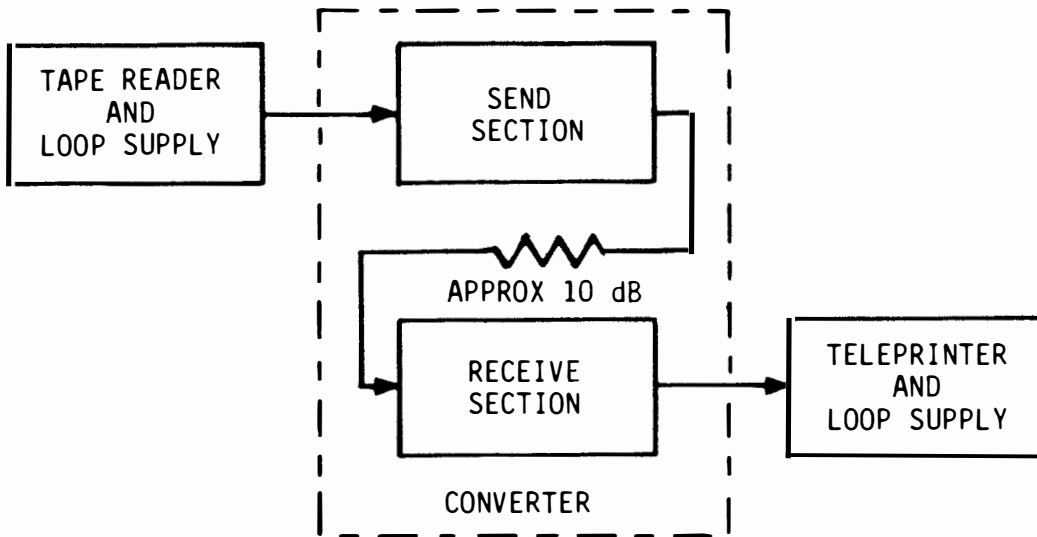

Figure 5-1. Back-to-Back Configuration

NOTE

S/R BTB to be used by qualified personnel only. With mode switch set to S/R BTB, the tone output of the send section connects internally to the tone input of the receive section. External tone lines and VOX closure are disconnected by the mode switch. Otherwise the converter is conditioned for full-duplex operation.

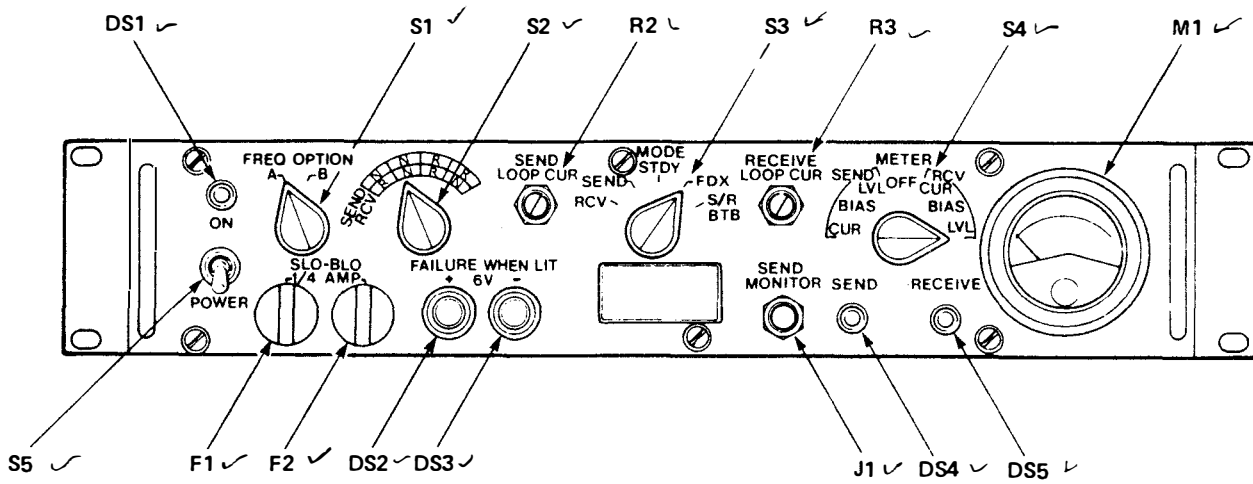

Figure 5-2. Chassis Parts Location, Front Panel

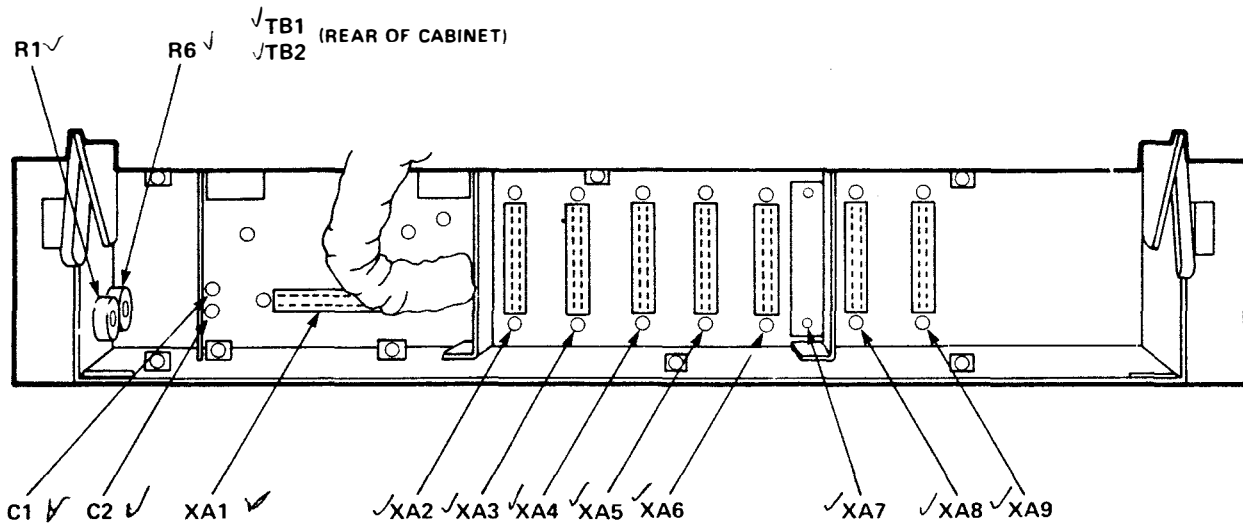

Figure 5-3. Chassis Parts Location, Interior (Sheet 1 of 2)

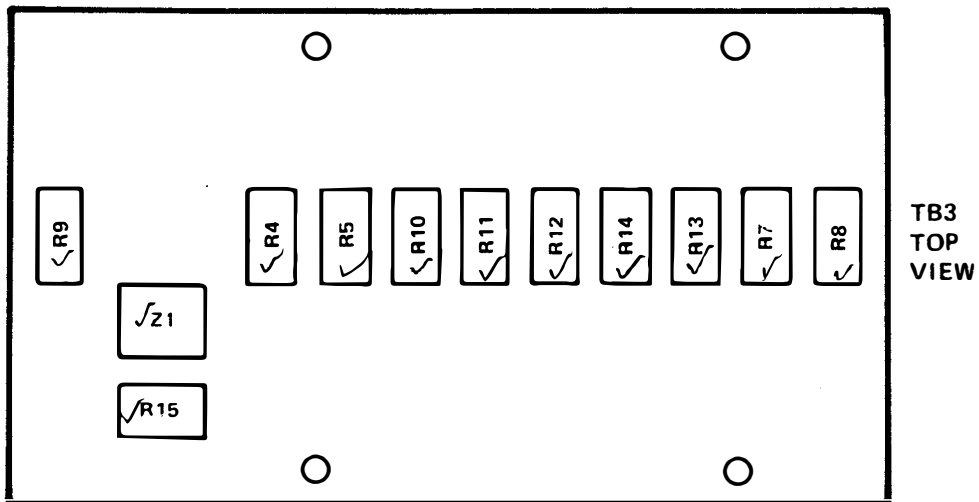
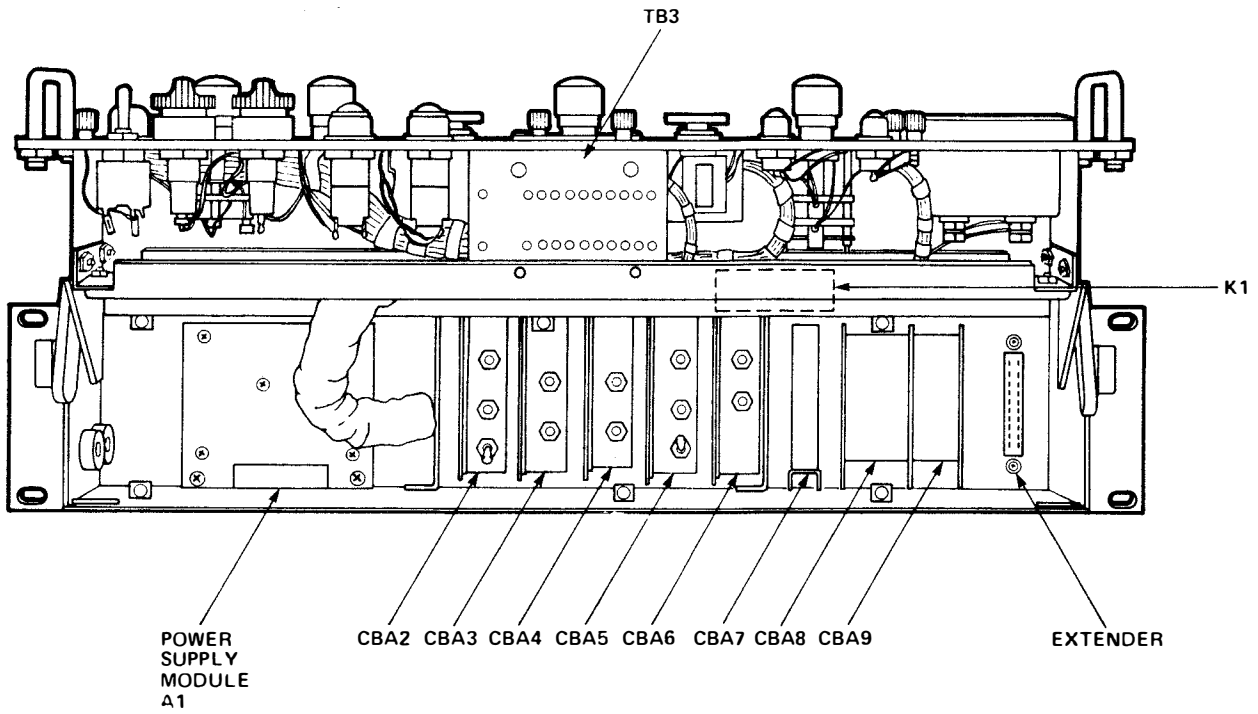

Figure 5-3. Chassis Parts Location, Interior (Sheet 2 of 2)

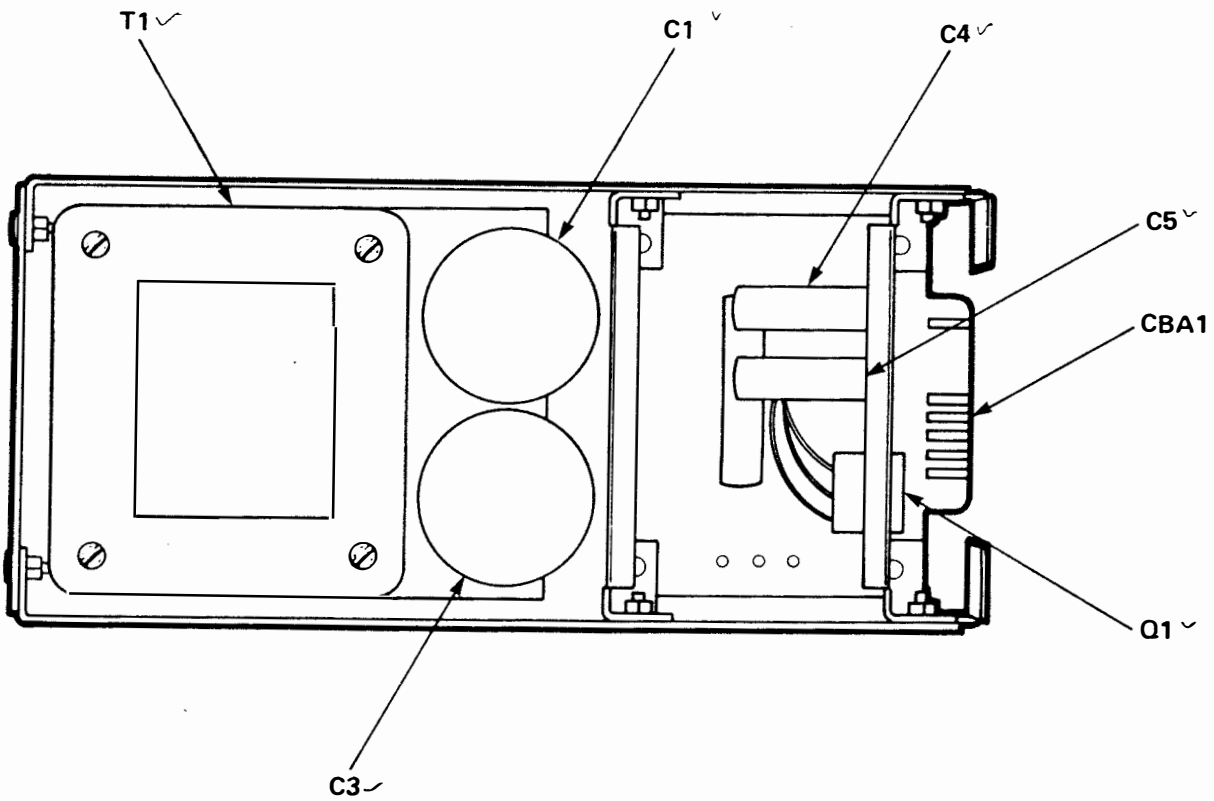
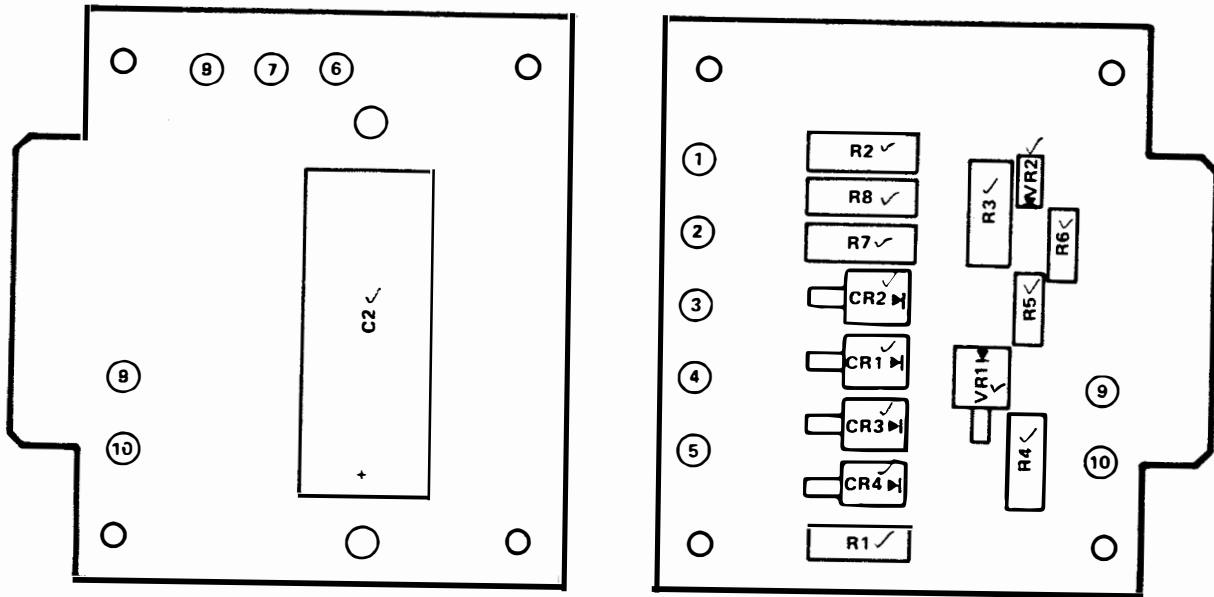

Figure 5-4. Power Supply, Module 1A1, Parts Location



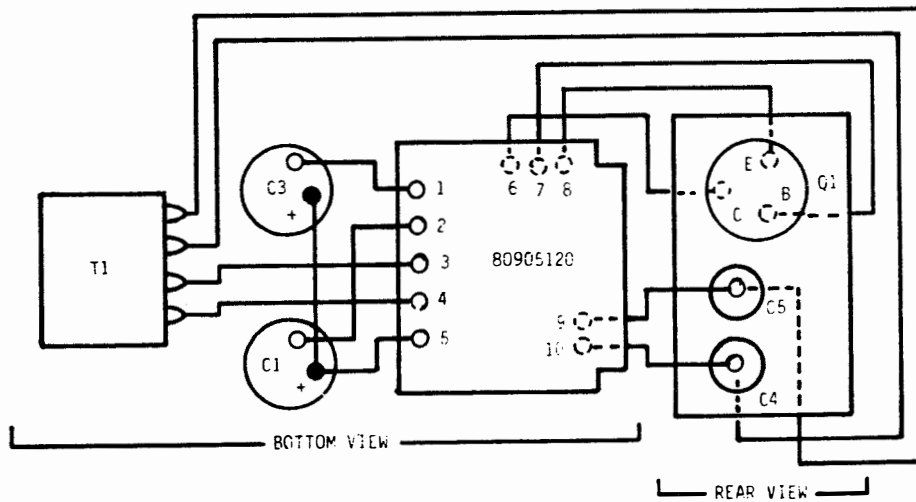

Figure 5-5. Power Supply, Module 1A1, Wiring Diagram

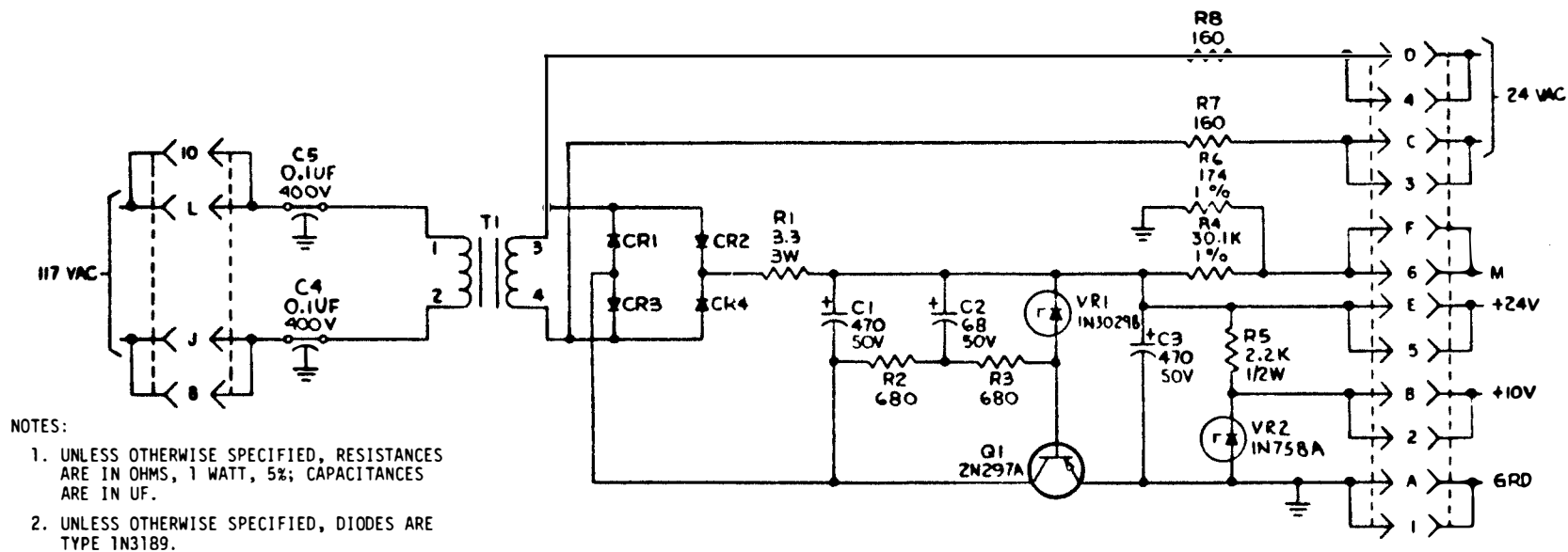

Figure 5-6. Power Supply, Module 1A1, Schematic Diagram

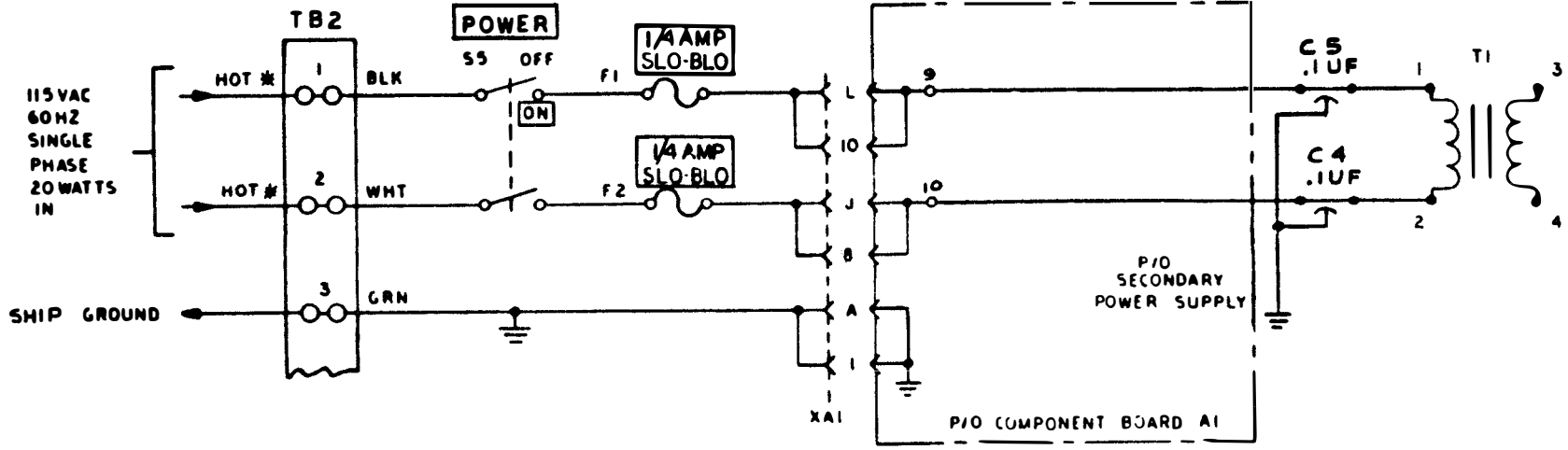

Figure 5-7. Primary Power Distribution

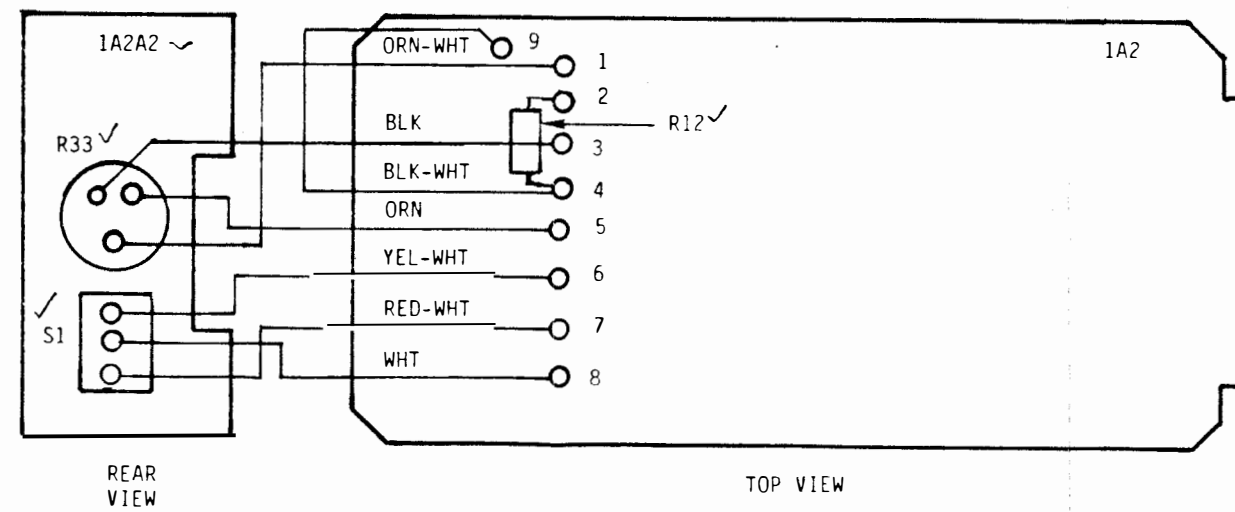
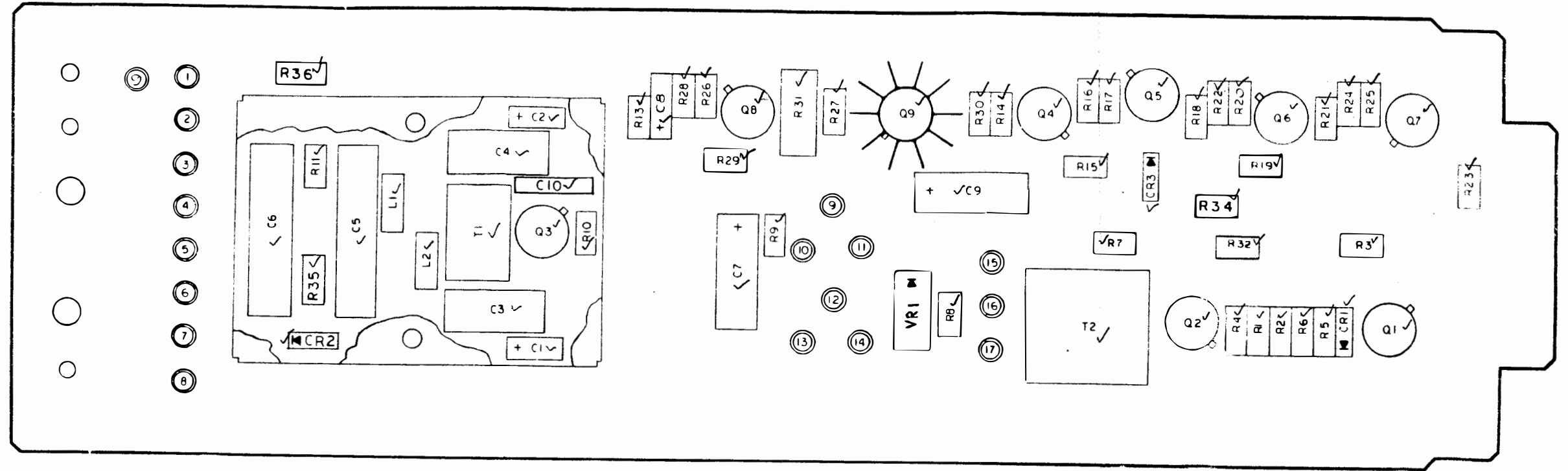

Figure 5-8. Component Board 1A2 (Send and Input), Wiring Diagram and Parts Location

GENERAL NOTES:

1. UNLESS OTHERWISE INDICATED, RESISTANCES ARE IN OHMS, 1/2 W,  $\pm 5\%$ ; CAPCITANCES ARE IN UF.
2. UNLESS OTHERWISE INDICATED, DIODES ARE TYPE 1N4148; TRANSISTORS ARE TYPE 2N1613.
3. FOR BOARD ASSEMBLY DRAWING, SEE FIGURE 5-8.
4.  INDICATES EQUIPMENT MARKINGS.
5. \* JUMPER INSTALLATION:
  - A. FOR 60mA: JUMP 15, 16, AND 17 TOGETHER
  - B. FOR NEUTRAL INPUT: CONNECT 9 TO 11 AND 12 TO 13.
  - C. FOR POLAR INPUT: CONNECT 9 TO 10 AND 12 TO 14.

NOTES (VOLTAGES & RESISTANCES):

1. NO SIGNALS APPLIED.
2. SWITCH SETTINGS:
  - MODE - STBY
  - METER - OFF
  - KEYING - SEND N-RCV N
  - FREQ OPTION - A
  - 600 $\Omega$  - 50 $\Omega$  - 600 $\Omega$
  - .75SEC - 3SEC - .75SEC
3. READ VOLTAGES USING EXTENDER; POWER ON.
4. READ RESISTANCES WITH COMPONENT BOARD DISCONNECTED. CONNECT OHMMETER (-) LEAD TO COMMON AND (+) LEAD TO TEST POINT.
- ⑤ ELECTRONIC SWITCH Q1-Q2 RECEIVES OPERATING VOLTAGE FROM EXTERNAL LOW-LEVEL LOOP BATTERY ( $\pm 6V$ ).
- ⑥ OSCILLATOR Q3 RECEIVES OPERATING VOLTAGE FROM SEND LOOP SIGNAL.

VOLTAGES AND RESISTANCES

TRANSISTOR	EMITTER		BASE		COLLECTOR	
	VOLTS	OHMS	VOLTS	OHMS	VOLTS	OHMS
Q1 (P1-K COMMON)	SW ⑤	200	SW	1100	SW	$\infty$
Q2 (R7-TERMINAL 10 COMMON)	SW ⑤	$\infty$	SW	$\infty$	SW	30
Q3 (R9-C1 JUNCTION COMMON)	OSC ⑥	20	OSC	800	OSC	100
Q4 (P1-A COMMON)	0.25	20	0.0	800	23	7500
Q5 (P1-A COMMON)	0.25	40	10.0	800	23	7500
Q6 (P1-A COMMON)	0.00	0	0.1	800	23	4200
Q7 (P1-A COMMON)	23.0	8500	23.0	4200	23	1700
Q8 (P1-A COMMON)	15.0	700	2.0	1900	1	1500
Q9 (P1-A COMMON)	15.0	500	15.0	1500	23	1500

TEST POINT

WAVEFORM

OSCILLOSCOPE

P1-9  
(P1-B COMMON)

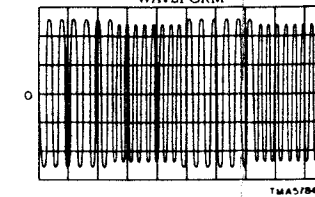

0.5V/CM  
5MS/CM

P1-10  
(P1-A COMMON)

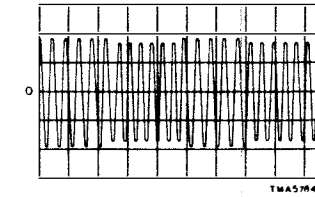

1V/CM  
5MS/CM

Q7 EMITTER  
(P1-A COMMON)

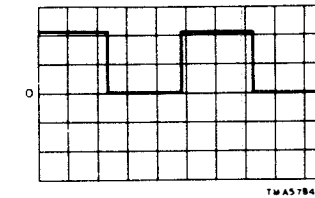

10V/CM  
5MS/CM

Q5 COLLECTOR  
(P1-A COMMON)

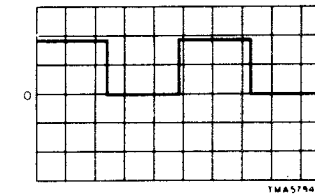

10V/CM  
5MS/CM

R11-R12 JUNCTION  
(P1-A COMMON)

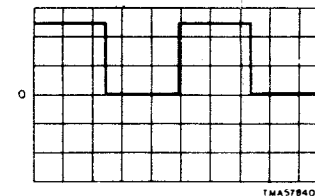

2V/CM  
5MS/CM

Q3 COLLECTOR  
(EMITTER COMMON)

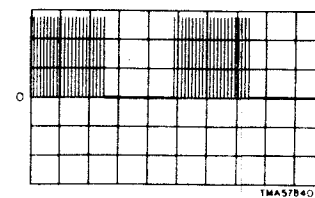

5V/CM  
5MS/CM

L1-C1 JUNCTION  
(L2-C1 COMMON)

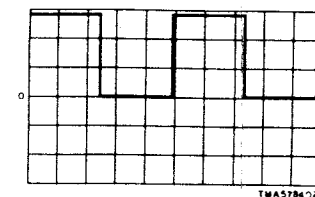

2V/CM  
5MS/CM

NOTES:

1. SEND SIGNAL (NEUTRAL, 75-BAUD REVERSALS) APPLIED TO TB1-6(+) AND TB1-7(-).
2. SWITCH SETTINGS:
  - MODE - S/R BTB
  - METER - OFF
  - KEYING - SEND N-RCV N
  - FREQ OPTION - A
  - POWER - ON
  - 600 $\Omega$  - 50 $\Omega$  - 600 $\Omega$
3. CONTROL SETTINGS:
  - OUT LEVEL - SET FOR ZERO DBM INDICATION ON METER, WITH METER SWITCH SET TO SEND LVL.

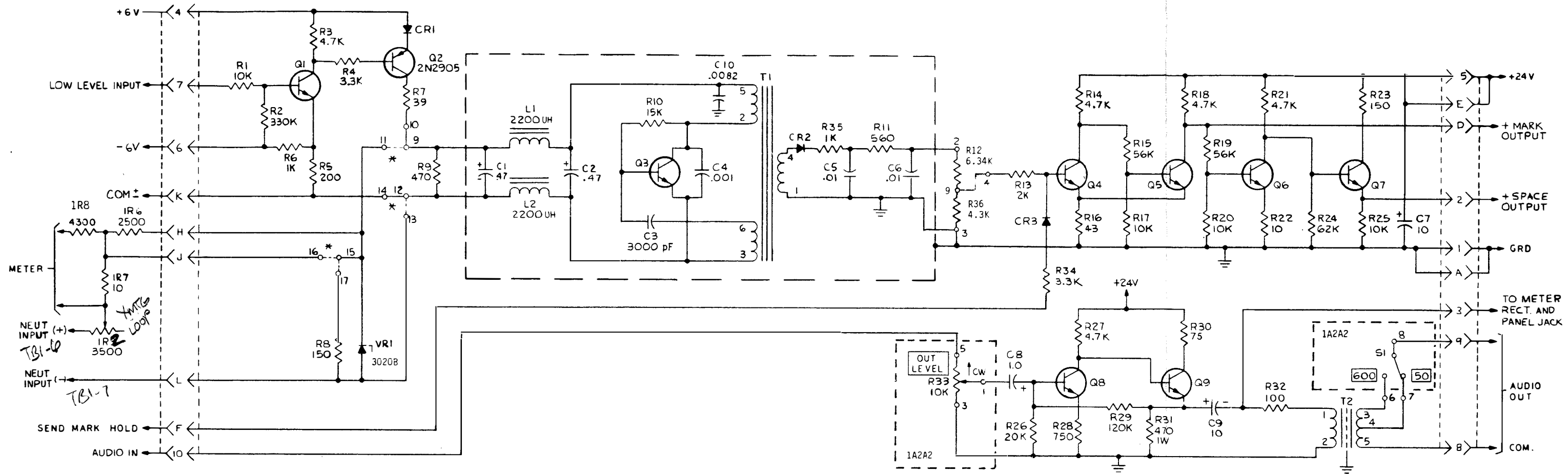

NOTES:

1. UNLESS OTHERWISE INDICATED, RESISTANCES ARE IN OHMS, 1/2W, ±5%, CAPACITANCES ARE IN UF.
2. UNLESS OTHERWISE INDICATED, DIODES ARE TYPE IN4148, TRANSISTORS ARE TYPE 2N1613.
- \* JUMP 15, 16 AND 17 TOGETHER FOR 60MA
  - A. FOR NEUTRAL INPUT, CONNECT 9 TO 11 AND 12 TO 13.
  - B. FOR POLAR INPUT, CONNECT 9 TO 10 AND 12 TO 14.
3. FOR COMP BD ASSY SEE DWG 80205010
4.  INDICATES EQUIPMENT MARKINGS.

Figure 5-9. Component Board 1A2 (Send and Input), Schematic Diagram

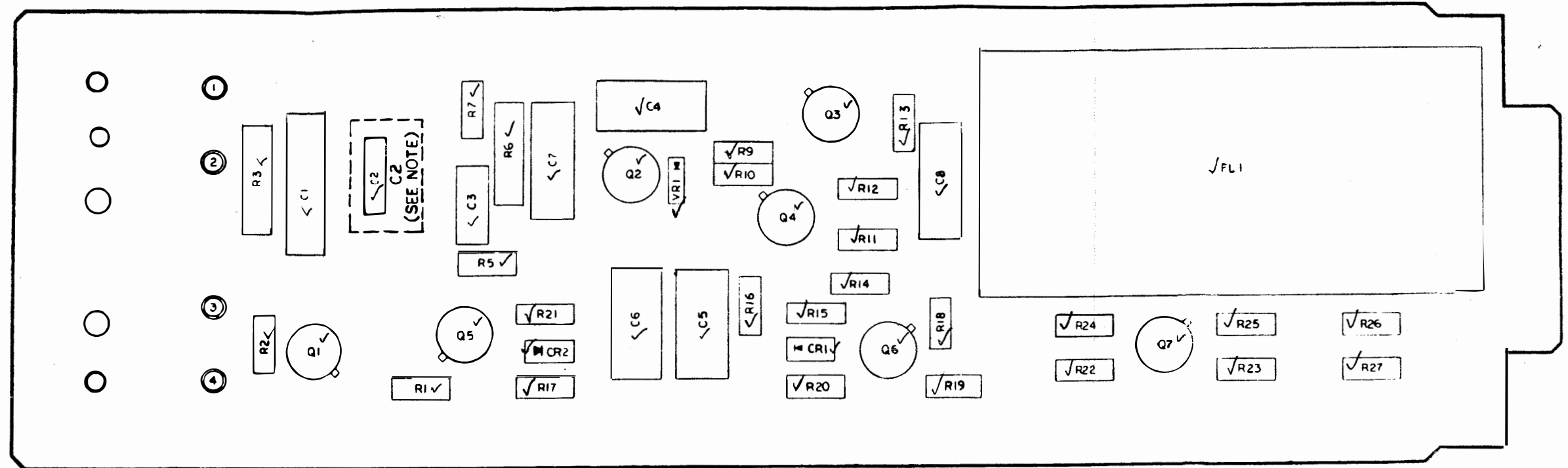

**NOTE**  
 THE LOCATION AND OUTLINE OF  
 C2 ON COMPONENT BOARD A3 IS  
 INDICATED BY THE DASHED LINES.

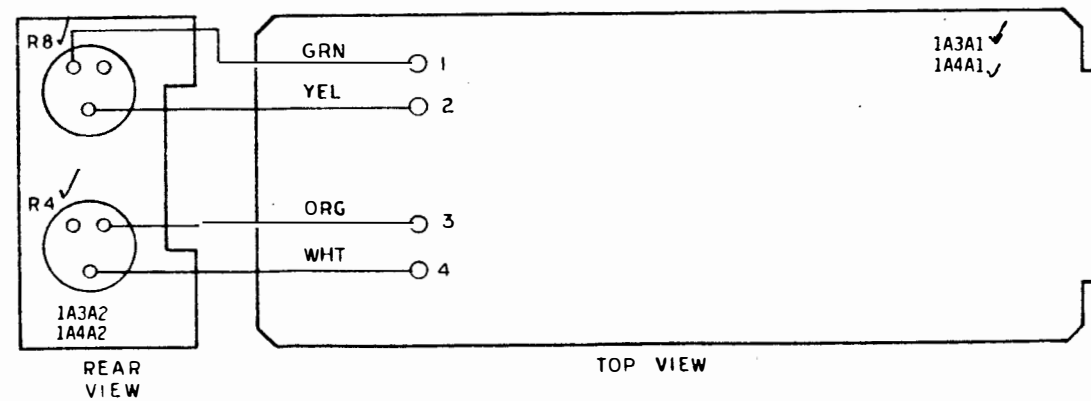

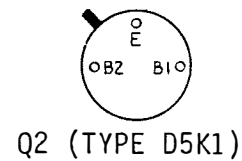

Figure 5-10. Component Boards 1A3 (Oscillator A) and 1A4 (Oscillator B), Wiring Diagram and Parts Location

GENERAL NOTES:

- UNLESS OTHERWISE INDICATED, RESISTANCES ARE IN OHMS,  $\pm 5\%$ , 1/2W. CAPACITANCES ARE IN UF.
- UNLESS OTHERWISE INDICATED, DIODES ARE TYPE 1N4148; TRANSISTORS ARE TYPE 2N1613.
-  INDICATES EQUIPMENT MARKINGS.
- 1A3, COMP. ASSY NO. 80205020-001  
1A4, COMP. ASSY NO. 80205020-002

UNIT		R <sub>S</sub> *	R <sub>M</sub> *	C1	C2	C3
LO. BAND	F <sub>M</sub> = 700	291K	124K	0.0047	0.0051	$\cong$
1A3	F <sub>S</sub> = 500	1/4W	1/4W	POLY	CM35	360 PF
HI. BAND	F <sub>M</sub> = 2425	215K	124K	0.0022	750PF	360 PF
1A4	F <sub>S</sub> = 1575	1/4W	1/4W	POLY	CM06	CM



VOLTAGES AND RESISTANCES

TRANSISTOR	EMITTER		BASE		COLLECTOR	
	VOLTS	OHMS	VOLTS	OHMS	VOLTS	OHMS
Q1 (P1-1 COMMON)	0.0	0	0.0	800	6	350K
Q2 (P1-1 COMMON)	0.5(B2)	700(B2)	7.5(E)	120K(E)	12(B1)	4000(B1)
Q3 (P1-1 COMMON)	0.0	0	0.0	800	12	10K
Q4 (P1-1 COMMON)	0.0	0	0.0	800	12	10K
Q5 (P1-1 COMMON)	0.0	0	0.7	800	6	7K
Q6 (P1-1 COMMON)	0.0	0	0.7	800	6	4500
Q7 (P1-1 COMMON)	6.0	1200	5.0	2400	17	3000

NOTES:

- NO SIGNALS APPLIED.
- SWITCH SETTINGS:  
MODE - STBY  
METER - OFF  
KEYING - SEND N-RCV N
- FREQ OPTION SWITCH SET TO A FOR COMPONENT BOARD A3. SET TO B FOR COMPONENT BOARD A4.
- READ VOLTAGES USING EXTENDER; POWER ON.
- READ RESISTANCES WITH COMPONENT BOARD DISCONNECTED. CONNECT OHMMETER (-) LEAD TO COMMON AND (+) LEAD TO TEST POINT.

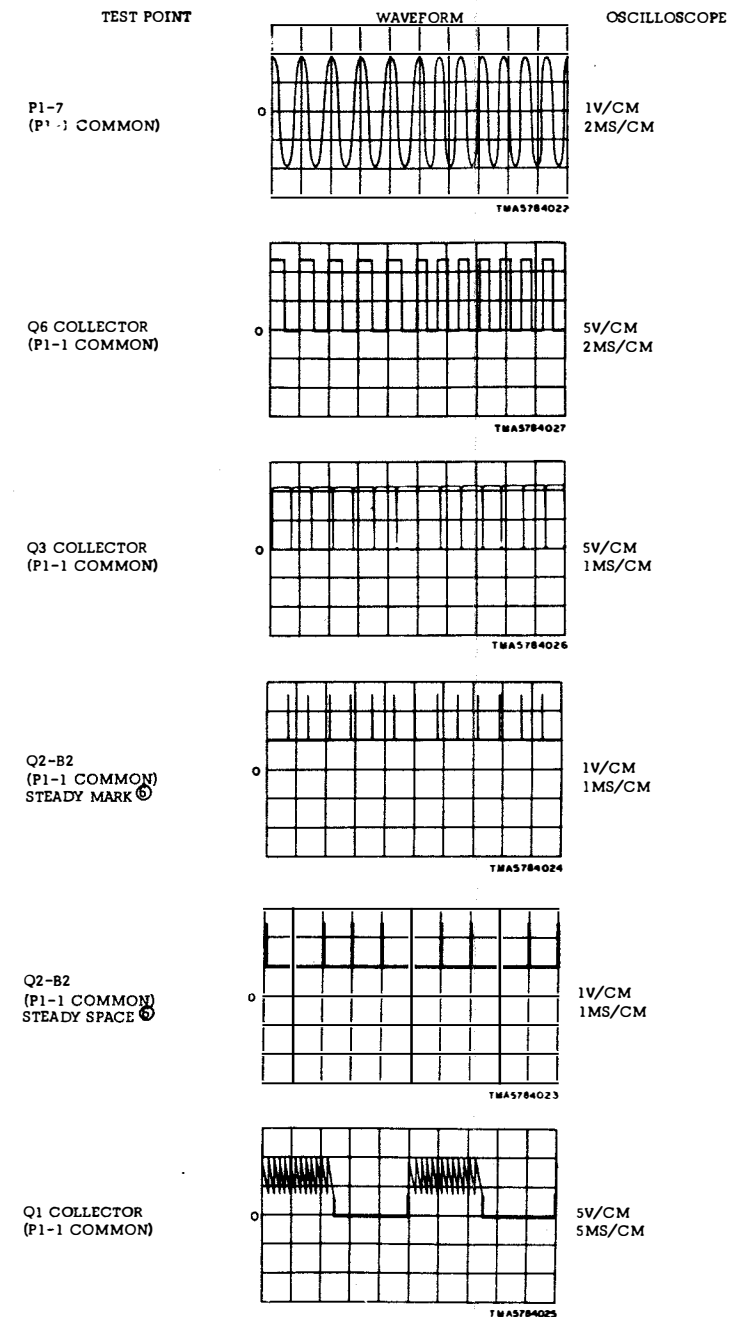

NOTES:

- SEND SIGNAL (NEUTRAL, 75-BAUD REVERSALS) APPLIED.
- SWITCH SETTINGS:  
MODE - S/R BTB  
METER - OFF  
KEYING - SEND N-RCV N  
POWER - ON  
600 $\Omega$  - 50 $\Omega$  - 600 $\Omega$
- FREQ OPTION SWITCH SET TO A FOR COMPONENT BOARD A3. SET TO B FOR COMPONENT BOARD A4.
- WAVEFORMS SHOWN ARE FOR COMPONENT BOARD A3. WAVEFORMS FOR COMPONENT BOARD A4 ARE THE SAME, EXCEPT FREQUENCIES ARE HIGHER.
- CONTROL SETTINGS:  
OUT LEVEL - SET FOR ZERO DBM INDICATION ON METER, WITH METER SWITCH SET TO SEND LVL.  
500Hz - SET FOR 500Hz AS MONITORED AT SEND MONITOR JACK, WITH SEND SIGNAL AT STEADY SPACE AND FREQ OPTION SWITCH SET TO A.  
700Hz - SET FOR 700Hz AS MONITORED AT SEND MONITOR JACK, WITH SEND SIGNAL AT STEADY MARK AND FREQ OPTION SWITCH SET TO A.  
1575Hz - SET FOR 1575Hz AS MONITORED AT SEND MONITOR JACK, WITH SEND SIGNAL AT STEADY SPACE AND FREQ OPTION SWITCH SET TO B.  
2425Hz - SET FOR 2425Hz AS MONITORED AT SEND MONITOR JACK, WITH SEND SIGNAL AT STEADY MARK AND FREQ OPTION SWITCH SET TO B.

Ⓢ SEND SIGNAL SET TO STEADY MARK OR SPACE AS INDICATED.



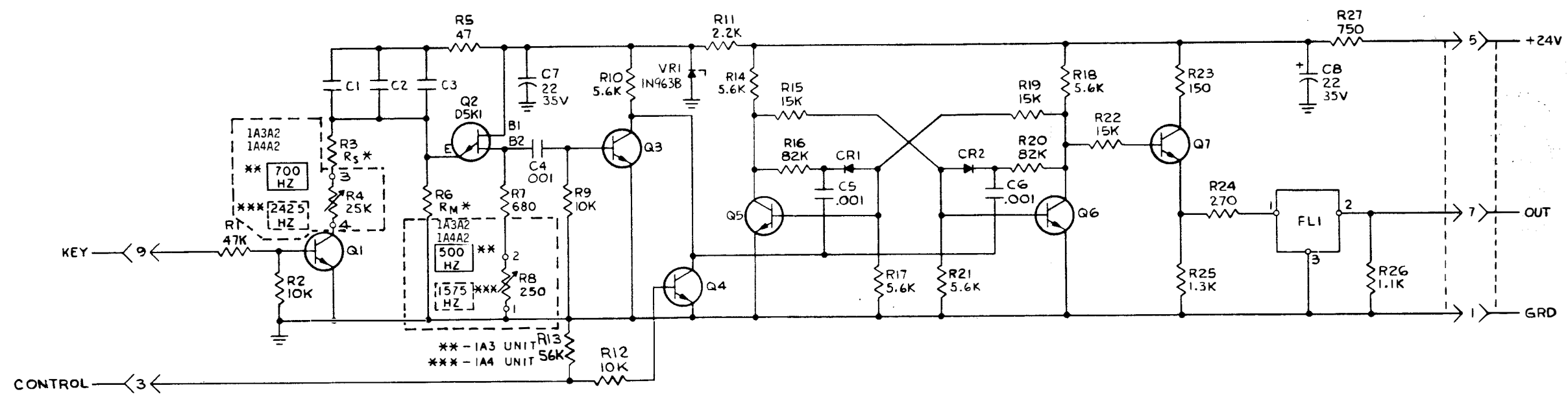

Figure 5-11. Component Boards 1A3 (Oscillator A) and 1A4 (Oscillator B), Schematic Diagram

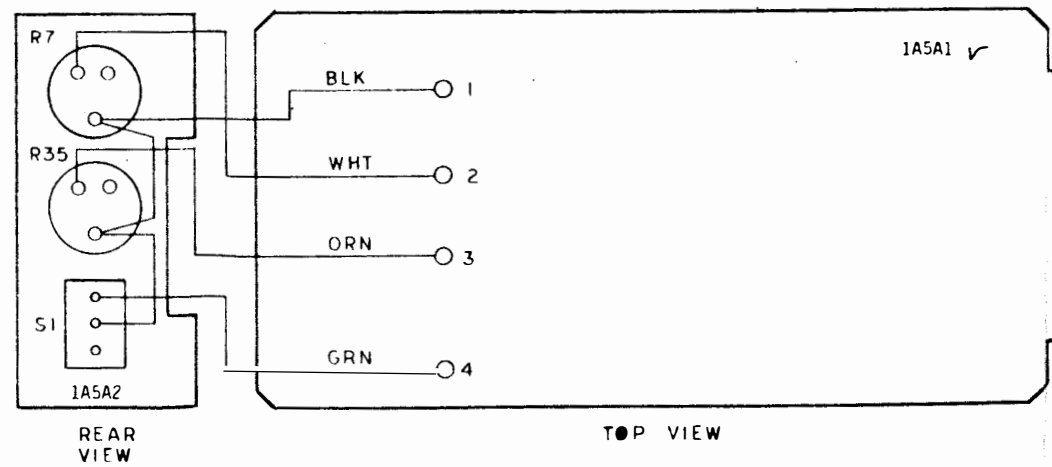
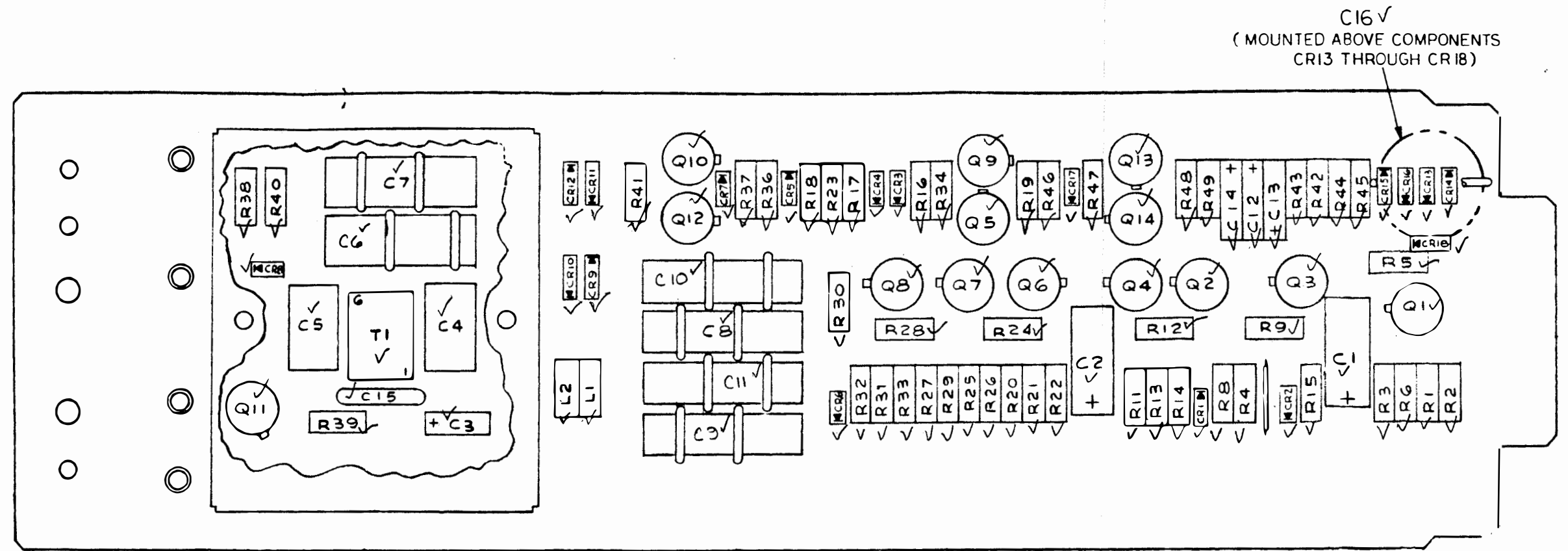

Figure 5-12. Component Board 1A5 (Control Network),  
Wiring Diagram and Parts Location

- GENERAL NOTES:
1. UNLESS OTHERWISE INDICATED, RESISTANCES ARE IN OHMS, 1/2 W, ±5%; CAPACITANCES ARE IN UF.
  2. UNLESS OTHERWISE INDICATED, DIODES ARE TYPE 1N4148; TRANSISTORS ARE TYPE 2N1613.
  3. FOR BOARD ASSEMBLY DRAWING, SEE FIGURE 5-12.
  4.   INDICATES EQUIPMENT MARKINGS.
  - TO BE DETERMINED.

VOLTAGES AND RESISTANCES

TRANSISTOR	EMITTER		BASE		COLLECTOR	
	VOLTS	OHMS	VOLTS	OHMS	VOLTS	OHMS
Q1 (P1-1 COMMON)	22.00	20K	22.50	15K	24.0	11K
Q2 (P1-1 COMMON)	20.00	2000	21.00	4000	22.0	11K
Q3 (P1-1 COMMON)	0.00	0	0.70	800	0.3	∞
Q4 (P1-1 COMMON)	0.00	0	0.35	750	0.1	20K
Q5 (P1-1 COMMON)	0.35	700	0.70	3000	0.4	15K
Q6 (P1-1 COMMON)	0.00	11K	0.00	9500	24.0	9500
Q7 (P1-1 COMMON)	0.00	2300	0.00	4500	24.0	11K
Q8 (P1-1 COMMON)	0.00	20	0.00	800	24.0	11K
Q9 (P1-1 COMMON)	0.35	400	0.70	800	0.4	15K
Q10 (P1-1 COMMON)	22.00	2100	21.50	29K	22.0	1700
Q11 (P1-1 COMMON)	5.00	0	1.00	750	0.0	100
Q12 (P1-1 COMMON)	SW	2000	SW	600	SW	0
Q13 (P1-1 COMMON)	0.00	0	0.00	800	13.0	15K
Q14 (P1-1 COMMON)	0.00	0	0.35	800	0.1	4500

- NOTES:
1. NO SIGNALS APPLIED.
  2. SWITCH SETTINGS:  
MODE - STBY  
METER - OFF  
KEYING - SEND N-RCV N  
FREQ OPTION - A  
.75SEC - 3SEC - .75SEC
  3. READ VOLTAGES USING EXTENDER POWER ON.
  4. READ RESISTANCES WITH COMPONENT BOARD DISCONNECTED. CONNECT OHMMETER (-) LEAD TO COMMON AND (+) LEAD TO TEST POINT.
  5. ELECTRONIC SWITCH Q12 RECEIVES OPERATING VOLTAGE FROM EXTERNAL VOX CIRCUITS (IF ANY).

CONTROL SIGNAL VOLTAGES

MODE SWITCH SETTING	Q2 EMITTER	Q4 COLLECTOR	Q5 COLLECTOR	Q7 EMITTER	Q8 COLLECTOR	Q14 COLLECTOR
RCV (REC AND SEND SIGS ACTIVE)	0	15.0	0.8	22.0	1.5	23.0
SEND (REC AND SEND SIGS ACTIVE)	8	0.1	0.8	0.0	24.0	24.0
STBY (NO SIGNALS)	0	14.0	24.0	0.0	24.0	0.1
STBY (REC SIG ACTIVE)	0	14.0	0.8	21.0	1.4	23.0
STBY (SEND SIG ACTIVE)	20	0.1	0.8	0.0	24.0	0.1
FDX (REC AND SEND SIGS ACTIVE)	8	0.0	0.8	9.0	1.3	23.0
S/R BTB (SEND SIG ACTIVE)	8	0.1	0.8	8.5	1.3	23.0

- NOTES:
1. THE ABOVE VOLTAGE LEVELS, MEASURED WITH AN OSCILLOSCOPE, SHOULD BE PRESENT AT THE TEST POINTS INDICATED (P1-1 COMMON) FOR EACH SETTING OF THE MODE SWITCH. APPLY SEND AND RECEIVE SIGNALS AS INDICATED.
  2. APPLY A 75-BAUD REVERSALS SEND SIGNAL TO T81-6 AND T81-7. APPLY A 600Hz RECEIVE SIGNAL TO T82-7 AND T82-8.
  3. ADJUST RCV LEVEL CONTROL FOR -10DBM INDICATION ON METER WITH METER SWITCH SET TO REC LVL.

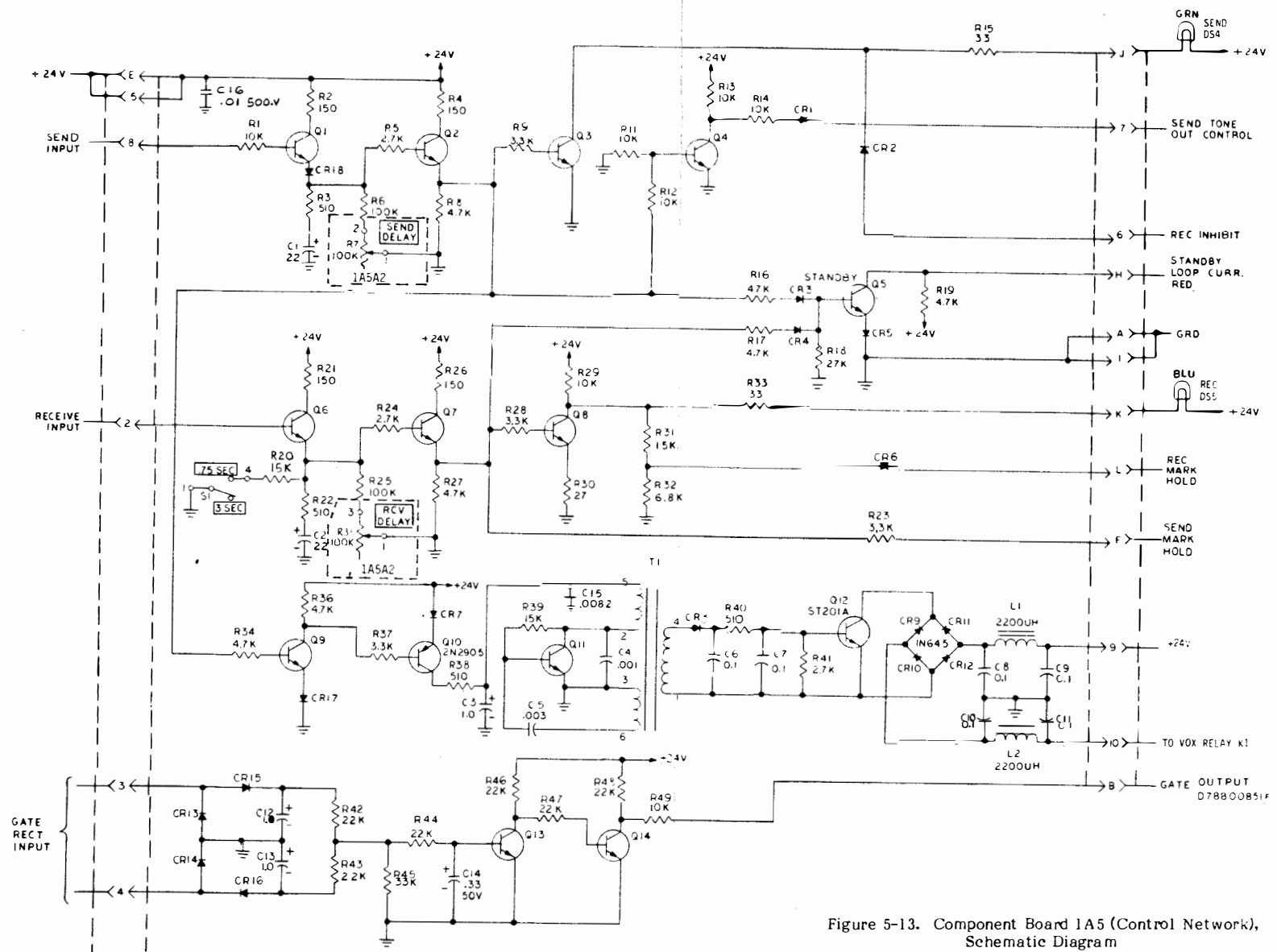

Figure 5-13. Component Board IA5 (Control Network), Schematic Diagram

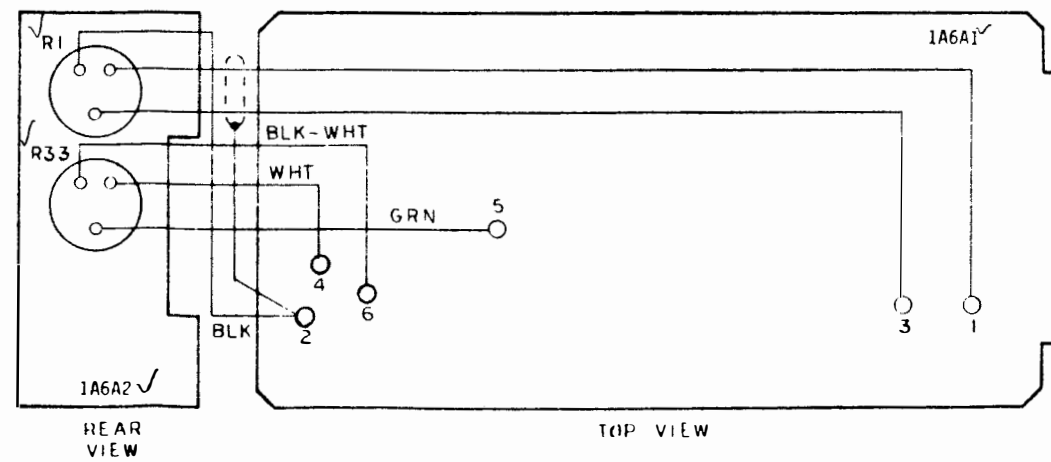
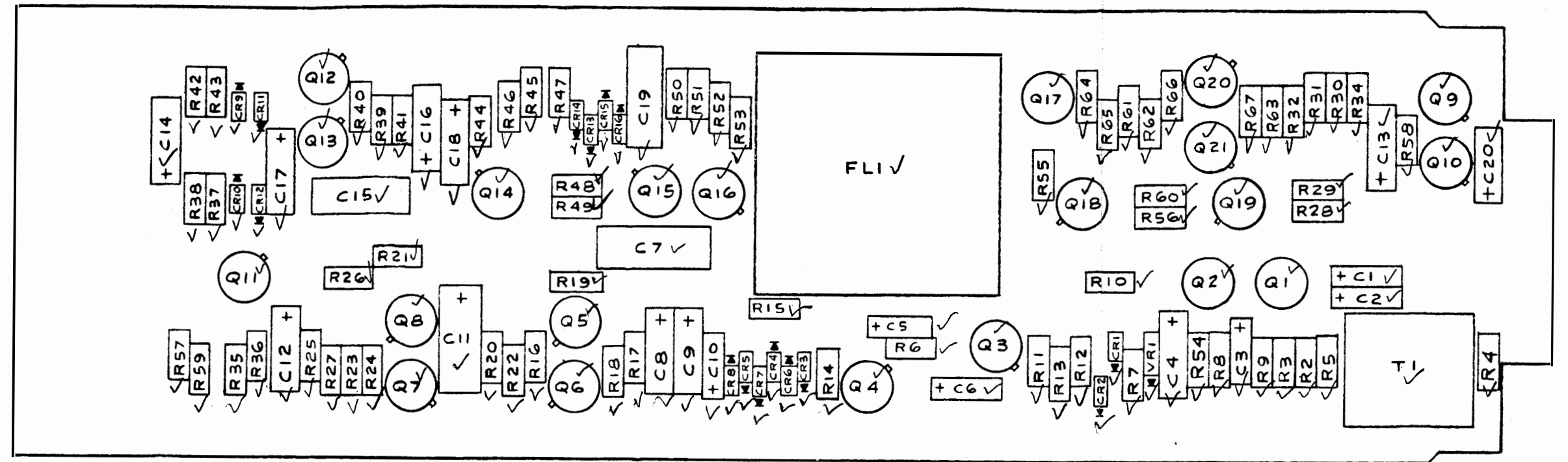

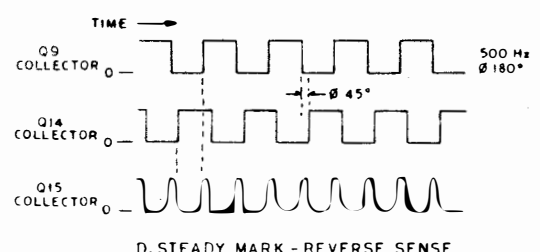
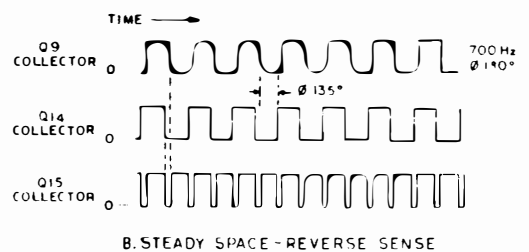
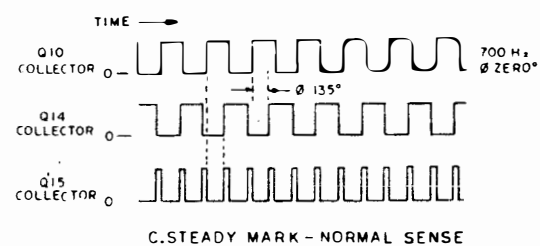
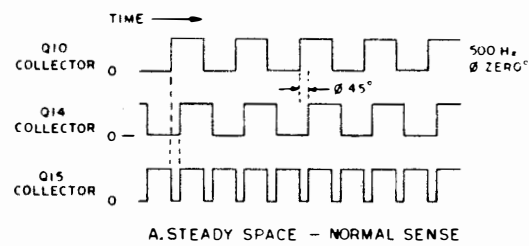

Figure 5-14. Component Board 1A5 (Receive),  
Wiring Diagram and Parts Location

GENERAL NOTES:

- UNLESS OTHERWISE INDICATED, RESISTANCES ARE IN OHMS, 1/2 W,  $\pm 5\%$ ; CAPACITANCES ARE IN UF.
- UNLESS OTHERWISE INDICATED, DIODES ARE TYPE 1N4148; TRANSISTORS ARE TYPE 2N1613.
- FOR BOARD ASSEMBLY DRAWING, SEE FIGURE 5-14.
-  INDICATES EQUIPMENT MARKINGS.
- POTS ARE RV-6.



NOTES:

- WAVEFORMS ARE SHOWN FOR LOW BAND OPERATION (FREQ OPTION SWITCH SET TO A) WITH SPACE AND MARK FREQUENCIES OF 500 HZ AND 700 HZ RESPECTIVELY. FOR HIGH BAND OPERATION (FREQ OPTION SWITCH SET TO B) THE WAVEFORMS ARE THE SAME EXCEPT SPACE AND MARK FREQUENCIES WOULD BE 1575 HZ AND 2425 HZ RESPECTIVELY.
- WAVEFORM SETS A AND C ARE OBTAINED WITH KEYING SWITCH SET TO NORM (NORMAL SENSE). WAVEFORM SETS B AND D ARE OBTAINED WITH KEYING SWITCH SET TO RVS (REVERSE SENSE).
- ANY TWO WAVEFORMS IN A SET MAY BE OBSERVED IN THEIR CORRECT PHASE RELATIONSHIP ON A DUAL TRACE OSCILLOSCOPE USING EXTERNAL TRIGGER FROM THE COLLECTOR OF Q8. ALL WAVEFORMS ARE REFERENCED TO CHASSIS GROUND.

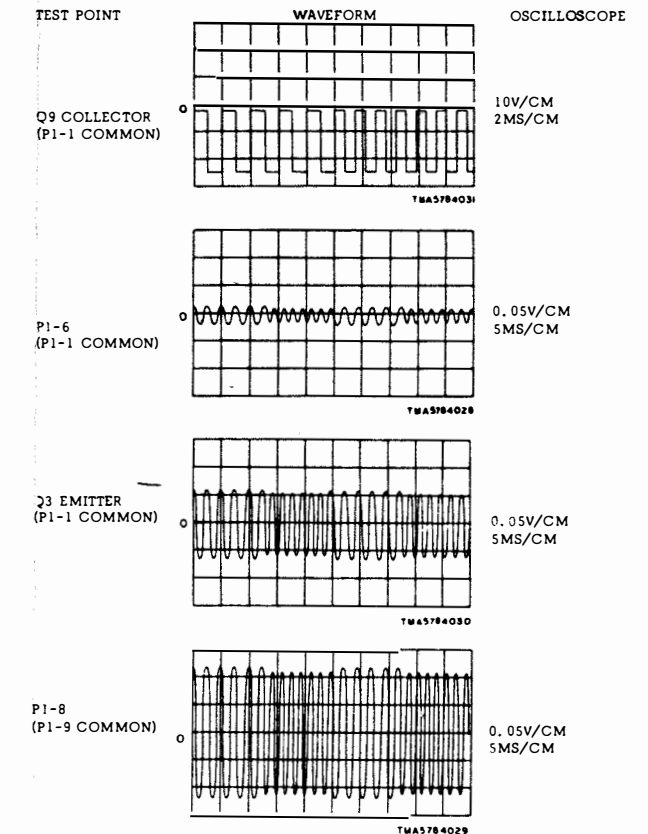
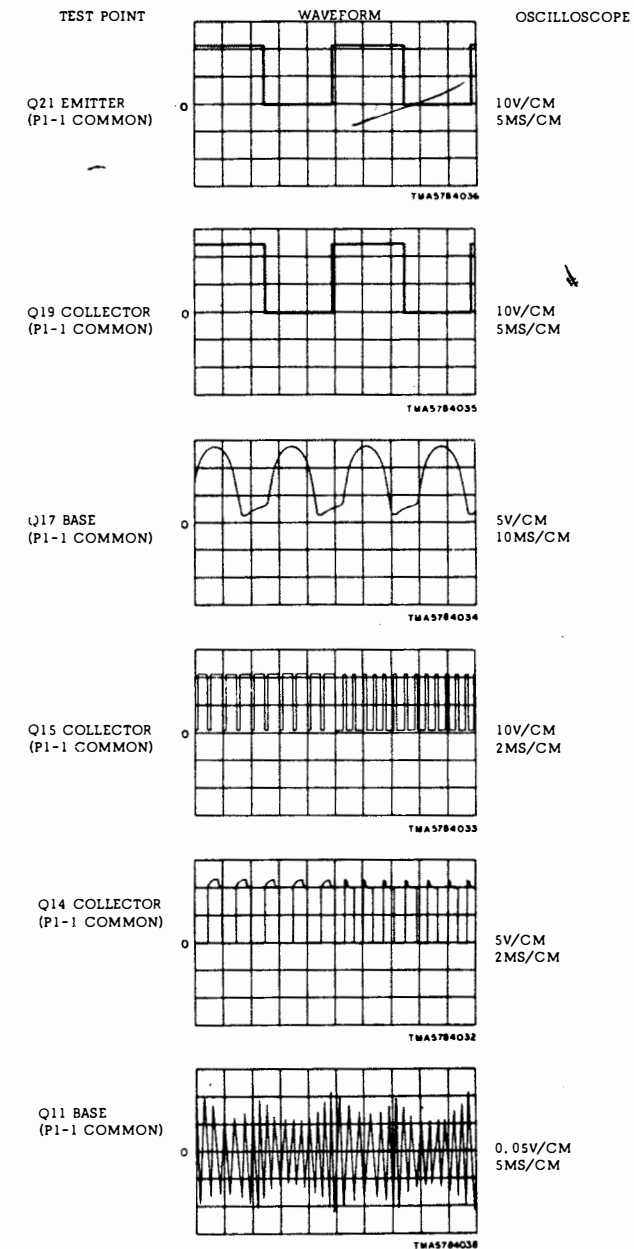

NOTES:

- SEND SIGNAL (NEUTRAL, 75-BAUD REVERSALS) APPLIED.
- SWITCH SETTINGS:  
MODE - S/R BTB  
METER - OFF  
KEYING - SEND N-RCV N  
FREQ OPTION - A  
POWER - ON  
600Ω - 50Ω - 600Ω  
.75SEC - 3SEC - .75SEC
- CONTROL SETTINGS:  
OUT LEVEL - SET FOR ZERO DBM INDICATION ON METER, WITH METER SWITCH SET TO SEND LVL.  
RCV LEVEL - SET FOR -10DBM INDICATION ON METER, WITH METER SWITCH SET TO REC LVL.  
BIAS - SET FOR ZERO INDICATION ON METER, WITH METER SWITCH SET TO REC BIAS.

VOLTAGES AND RESISTANCES

TRANSISTOR	EMITTER		BASE		COLLECTOR	
	VOLTS	OHMS	VOLTS	OHMS	VOLTS	OHMS
Q1 (P1-1 COMMON)	12.5	2600	12.50	3200	21.00	1700
Q2 (P1-1 COMMON)	0.0	3500	0.00	3500	21.00	1700
Q3 (P1-1 COMMON)	13.0	2600	12.50	3200	21.00	1700
Q4 (P1-1 COMMON)	8.0	2200	9.00	2800	22.00	1500
Q5 (P1-1 COMMON)	8.0	2200	9.00	2800	21.00	11K
Q6 (P1-1 COMMON)	22.0	1500	21.00	10K	10.00	2200
Q7 (P1-1 COMMON)	6.5	1700	7.00	1900	24.00	1300
Q8 (P1-1 COMMON)	6.5	1700	7.00	2400	16.00	3400
Q9 (P1-1 COMMON)	0.0	0	0.30	750	0.01	7000
Q10 (P1-1 COMMON)	0.0	0	0.01	750	23.00	7000
Q11 (P1-1 COMMON)	12.0	9000	11.00	3800	24.00	1200
Q12 (P1-1 COMMON)	0.0	0	1.00	750	5.00	4000
Q13 (P1-1 COMMON)	4.0	6000	5.00	3500	24.00	1900
Q14 (P1-1 COMMON)	0.0	0	1.00	750	12.00	7000
Q15 (P1-1 COMMON)	12.0	10K	12.50	6000	12.00	2200
Q16 (P1-1 COMMON)	11.5	1100	12.00	2200	23.00	1500
Q17 (P1-1 COMMON)	9.5	1700	8.00	2100	24.00	1300
Q18 (P1-1 COMMON)	9.5	1700	10.00	2600	22.00	15K
Q19 (P1-1 COMMON)	24.0	1300	23.00	30K	5.00	6000
Q20 (P1-1 COMMON)	0.0	0	1.40	1300	0.01	11K
Q21 (P1-1 COMMON)	0.0	10K	0.01	4000	24.00	1500

NOTES:

- NO SIGNALS APPLIED.
- SWITCH SETTINGS:  
MODE - STBY  
METER - OFF  
KEYING - SEND N - RCV N  
FREQ OPTION - A
- READ VOLTAGES USING EXTENDER; POWER ON.
- READ RESISTANCES WITH COMPONENT BOARD DISCONNECTED. CONNECT OHMMETER (-) LEAD TO COMMON AND (+) LEAD TO TEST POINT.

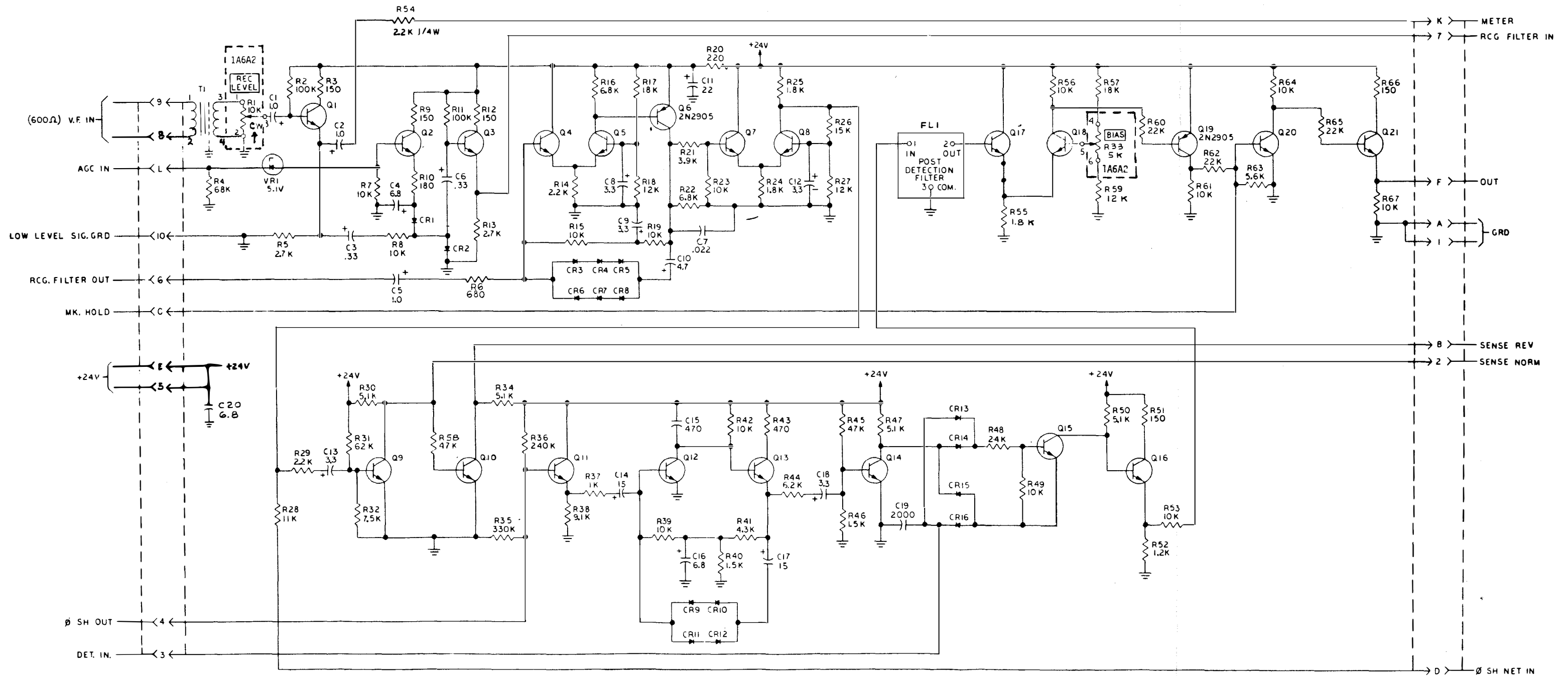

Figure 5-15. Component Board 1A6 (Receive), Schematic Diagram

A

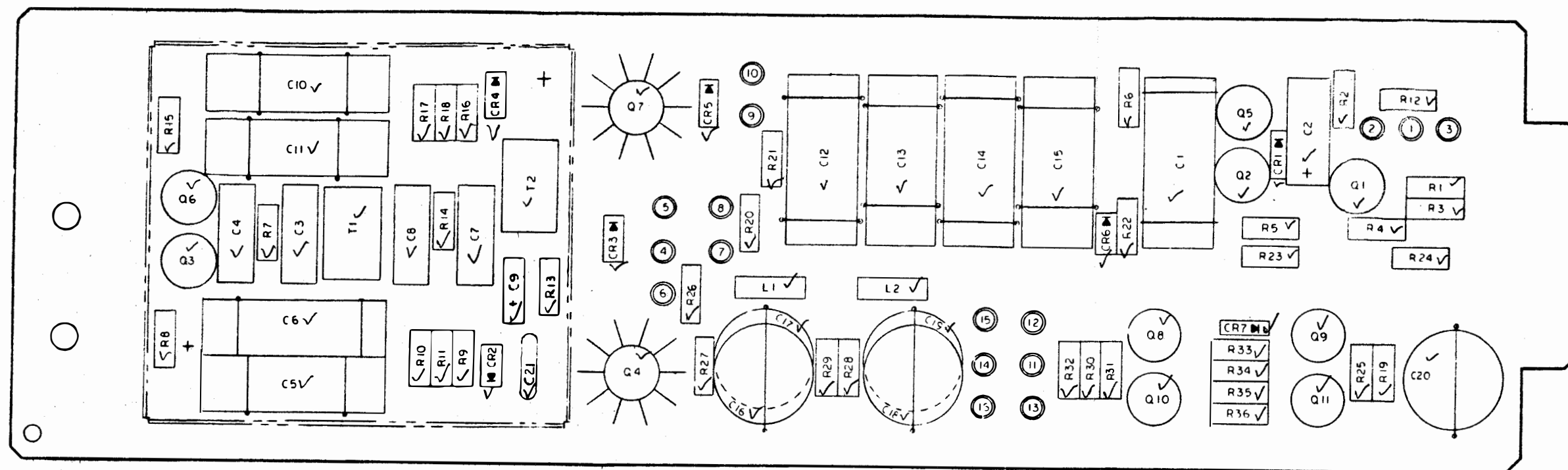
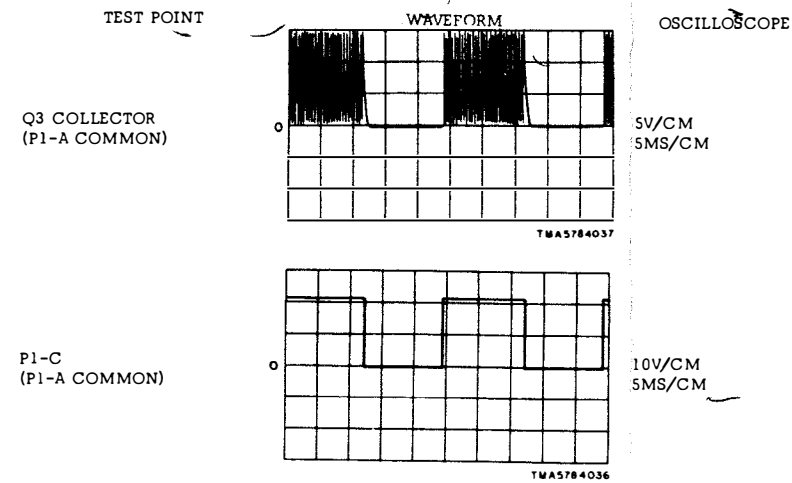

Figure 5-16. Component Board 1A7 (Loop Keying Network),  
Parts Location

GENERAL NOTES:

- UNLESS OTHERWISE INDICATED, RESISTANCES ARE IN OHMS, 1/2 W, +5%; CAPCITANCES ARE IN UF.
- UNLESS OTHERWISE INDICATED, DIODES ARE TYPE IN645; TRANSISTORS ARE TYPE 2N1613.
- FOR BOARD ASSEMBLY DRAWING, SEE FIGURE 5-16.
- INDICATES EQUIPMENT MARKINGS.
- FOR NEUTRAL OPERATION: JUMPER 1 TO 3, 4 TO 5, 7 TO 9, AND 9 TO 10.  
FOR POLAR OPERATION, JUMPER 2 TO 3, 4 TO 6, 7 TO 8, 11 TO 13, AND 14 TO 16.  
FOR HIGH LEVEL (VOLTAGE) OPERATION: JUMPER 2 TO 3, 4 TO 6, 7 TO 8, 11 TO 12, AND 14 TO 15.

*1-3, 4-5, 7-9, 9-10  
7-9 w/ correct limiting*



NOTES:

- SEND SIGNAL (NEUTRAL, 75-BAUD REVERSALS) APPLIED.
- SWITCH SETTINGS:  
MODE - S/R BTB  
METER - OFF  
KEYING - SEND N-RCV N  
FREQ OPTION - A  
POWER - ON  
600Ω - 50Ω - 600Ω  
.75SEC - 3SEC - .75SEC

VOLTAGES AND RESISTANCES

TRANSISTOR	EMITTER		BASE		COLLECTOR	
	VOLTS	OHMS	VOLTS	OHMS	VOLTS	OHMS
Q1 (P1-1 COMMON)	0.0	0	0.0	800	22	40K
Q2 (P1-1 COMMON)	11.0	1500	11.5	4500	21	40K
Q3 (P1-1 COMMON)	0.2	20	-0.5 <sup>ⓐ</sup>	800	12	1100
Q4 (Q7 COLLECTOR COMMON)	SW <sup>ⓑ</sup>	700	SW	2100	SW	∞
Q5 (P1-1 COMMON)	21.0	∞	20.0	∞	21	2600
Q6 (P1-1 COMMON)	0.2	20	-0.5 <sup>ⓐ</sup>	800	12	1900
Q7 (P1-2 COMMON)	SW <sup>ⓑ</sup>	700	SW	2100	SW	∞
Q8 (P1-9 COMMON)	SW	21K	SW	7K	SW	4500
Q9 (P1-9 COMMON)	SW	14K	SW	7K	SW	14K
Q10 (P1-9 COMMON)	SW	20K	SW	20K	SW	21K
Q11 (P1-9 COMMON)	SW	30K	SW	20K	SW	14K

NOTES:

- NO SIGNALS APPLIED.
- SWITCH SETTINGS:  
MODE - STBY  
METER - OFF  
KEYING - SEND N-RCV N  
FREQ OPTION - A
- READ VOLTAGES USING EXTENDER: POWER ON.
- READ RESISTANCES WITH COMPONENT BOARD DISCONNECTED. CONNECT OHMMETER (-) LEAD TO COMMON AND (+) LEAD TO TEST POINT.
- <sup>ⓑ</sup> SW INDICATES ELECTRONIC SWITCH THAT RECEIVES OPERATING VOLTAGE FROM EXTERNAL LOOP BATTERY.
- <sup>ⓐ</sup> (-) VOLTAGE IS DUE TO OSCILLATOR ACTION.



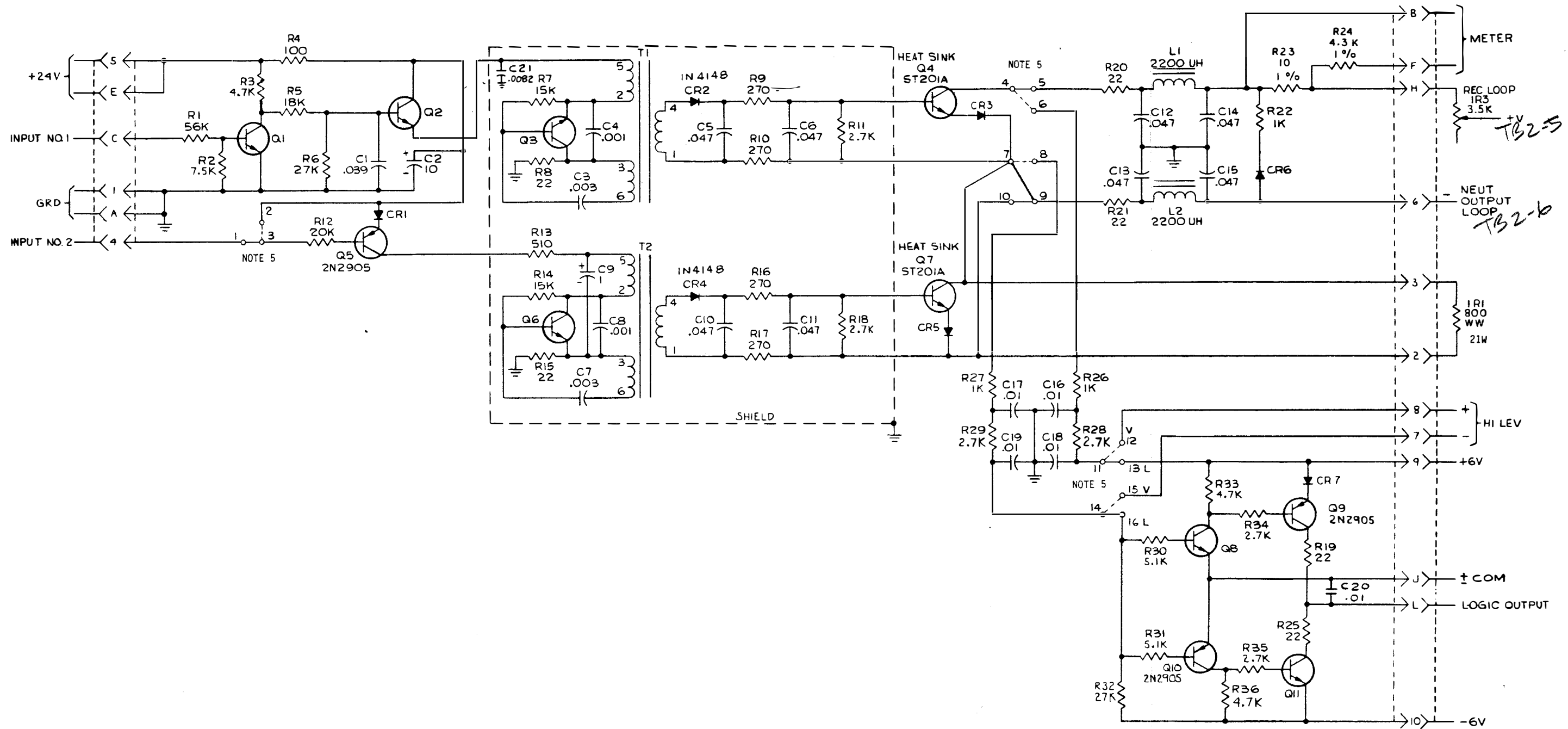

D78800853

Figure 5-17. Component Board 1A7 (Loop Keying Network), Schematic Diagram

A

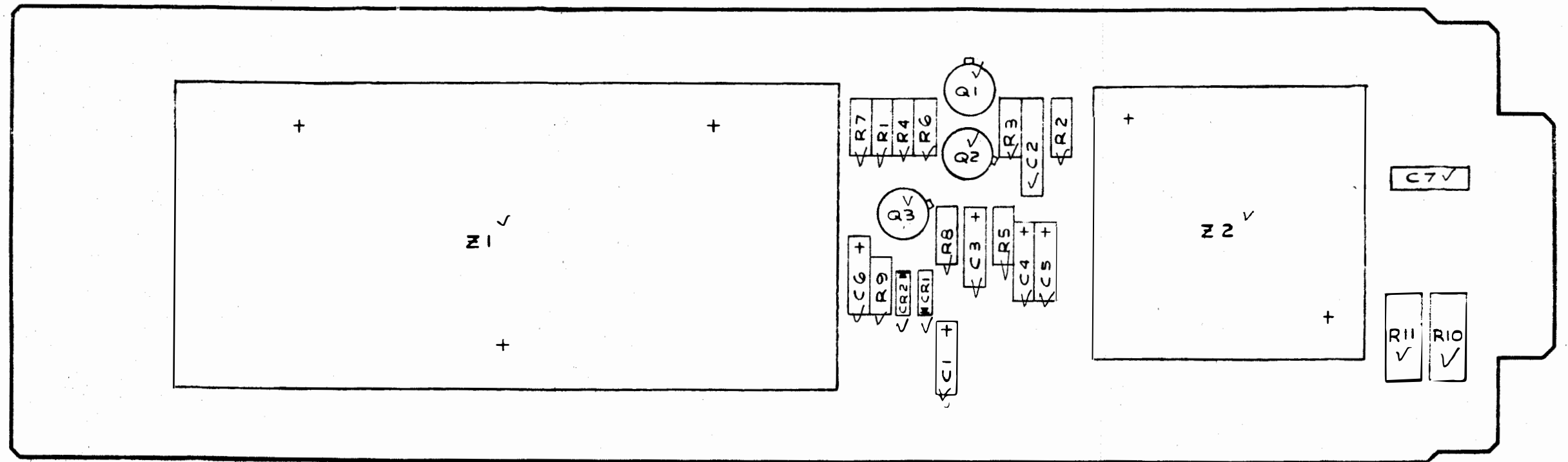
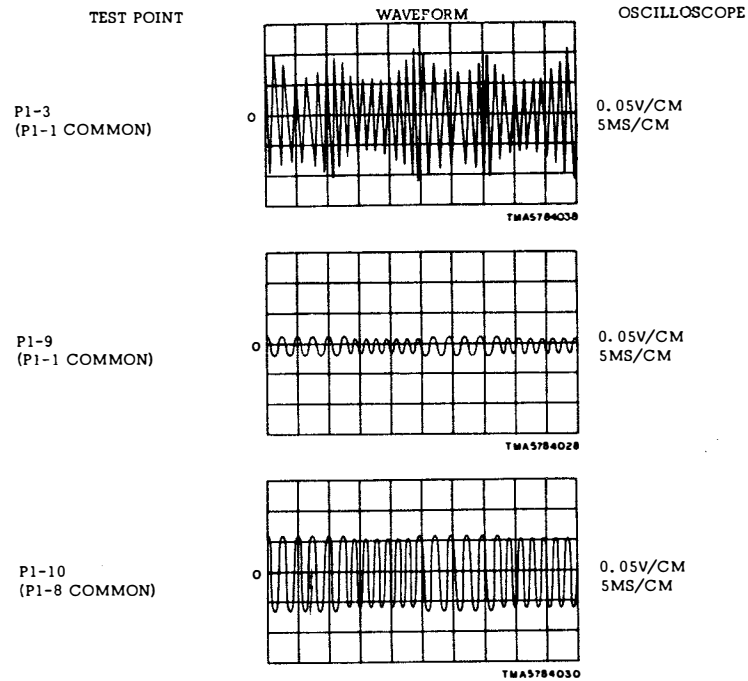

Figure 5-18. Component Boards 1A8 (Receive Filter, Low Band) and 1A9 (Receive Filter, High Band), Parts Location

- NOTES:
- UNLESS OTHERWISE INDICATED, RESISTANCES ARE IN OHMS, ±5%, 1/2W CAPACITANCES ARE IN UF.
  - ALL DIODES ARE 1N4148 TYPE, AND TRANSISTORS ARE 2N1613 TYPE, UNLESS OTHERWISE INDICATED.

\* FACTORY SELECTED  
 VALUE-1A8 180 TO 270, ±5%, 1/2W  
 VALUE-1A9 200 TO 390, ±5%, 1/2W

FREQ	CARD NO	Z1	Z2	COMP BD ASSY
A LO BAND	1A8	43020142	43006014	PC ao2o5o8o 001
B HI BAND	1A9	43020143	43006015	PC8 02050 80 00"



- NOTES:
- SEND SIGNAL (NEUTRAL, 75-BAUD REVERSALS) APPLIED.
  - SWITCH SETTINGS:  
 MODE - S/R BTB  
 METER - OFF  
 KEYING - SEND N-RCV N  
 POWER - ON  
 600Ω - 50Ω - 600Ω  
 .75SEC - 3SEC - .75SEC
  - FOR COMPONENT BOARD A8, SET FREQ OPTION SWITCH TO A. FOR COMPONENT BOARD A9, SET FREQ OPTION SWITCH TO B.
  - WAVEFORMS SHOWN ARE FOR COMPONENT BOARD A8. FOR COMPONENT BOARD A9, WAVEFORMS ARE THE SAME, EXCEPT FREQUENCIES ARE HIGHER.

VOLTAGES AND RESISTANCES

TRANSISTOR	EMITTER		BASE		COLLECTOR	
	VOLTS	OHMS	VOLTS	OHMS	VOLTS	OHMS
Q1 (P1-1 COMMON)	0.2	300	0.5	1300	5	3500
Q2 (P1-1 COMMON)	4.0	2000	5.0	3500	18	4000
Q3 (P1-1 COMMON)	17.5	3000	18.0	4000	24	5000

- NOTES:
- NO SIGNALS APPLIED.
  - SWITCH SETTINGS:  
 MODE - STBY  
 METER - OFF  
 KEYING - SEND N-RCV N
  - FOR COMPONENT BOARD A8, SET FREQ OPTION SWITCH TO A. FOR COMPONENT BOARD A9, SET FREQ OPTION SWITCH TO B.
  - READ VOLTAGES USING EXTENDER; POWER ON.
  - READ RESISTANCES WITH COMPONENT BOARD DISCONNECTED. CONNECT OHM-METER (-) LEAD TO COMMON AND (+) LEAD TO TEST POINT.

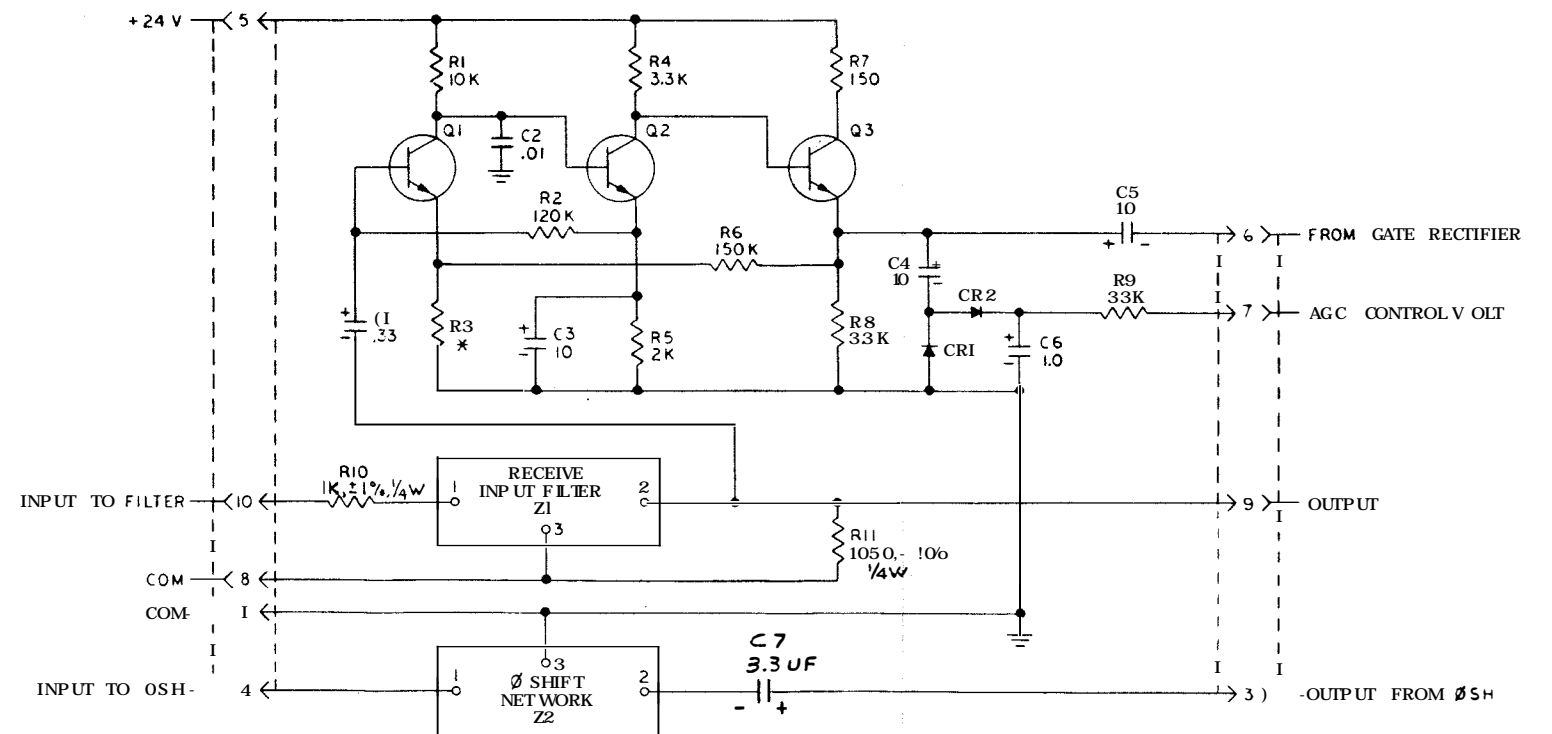

Figure 5-19. Component Boards 1A8 (Receive Filter, Low Band) and 1A9 (Receive Filter, High Band), Schematic Diagram

GENERAL NOTES:

1. THE NUMBER ON EACH WIRE (ADJACENT TO THE COMMON OR BASE LINE) CORRESPONDS TO THE LARGE NUMBER ADJACENT TO THE STATION TO WHICH THE WIRE RUNS.
2. ( ) DENOTES TERMINATION NUMBERS AND LETTERS.
3. — DENOTES JUMPER WIRE (LABELED NO. 10).

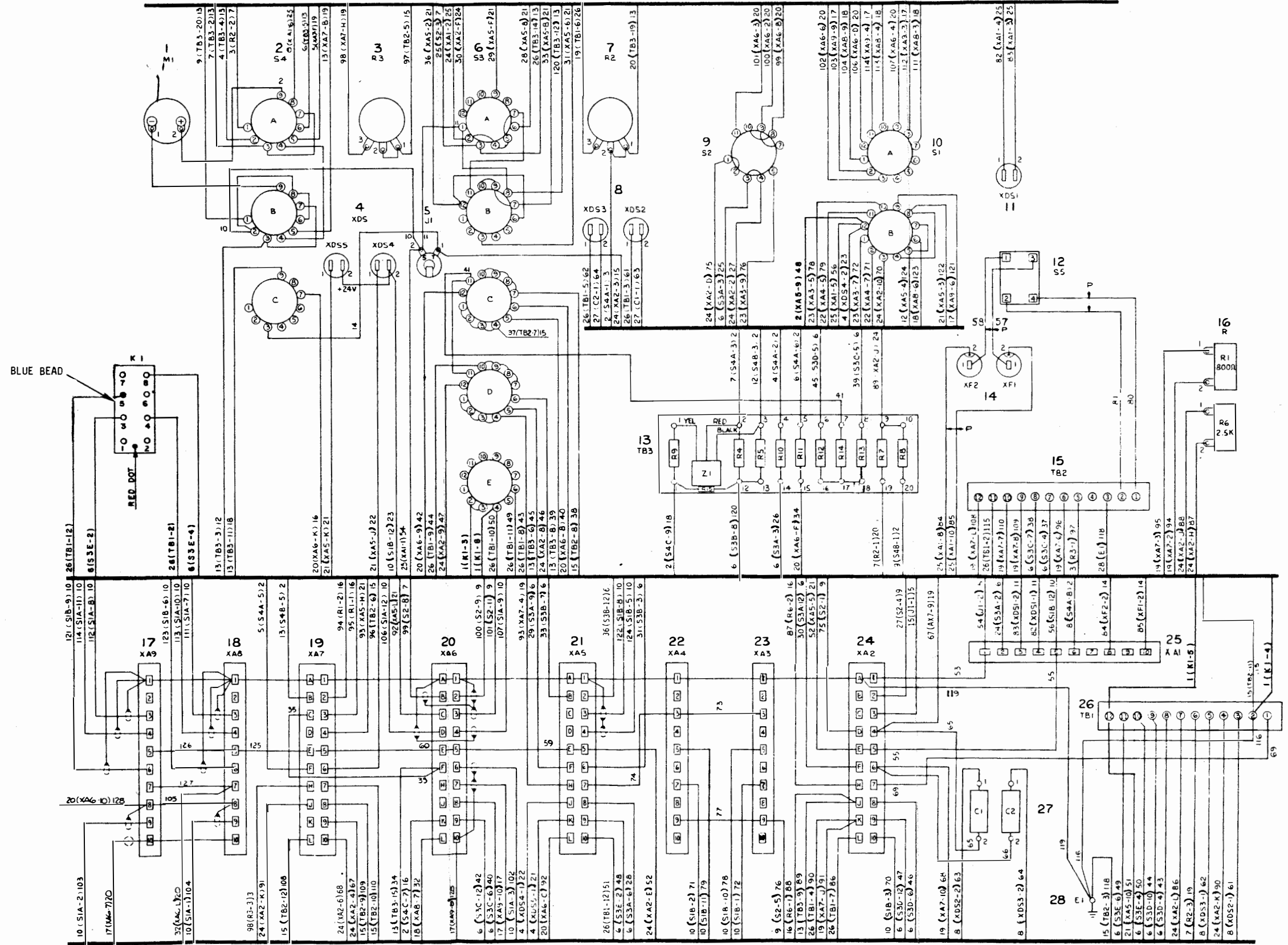

Figure 5-20. Converter Wiring Diagram

## CHAPTER 6

## CORRECTIVE MAINTENANCE

6-1. INTRODUCTION. This chapter provides information necessary to align and adjust subassemblies or modules found defective during troubleshooting.

6-2. ADJUSTMENTS AND ALIGNMENTS. Whenever a printed circuit board or other major component of the Converter has been repaired or replaced, first perform the Initial Checks and Adjustments described in chapter 8. After performing these adjustments, refer to paragraphs 6-2.2 through 6-2.8.

6-2.1. Front Panel Removal. To gain access to printed circuit board and components within the Converter and to make adjustment, raise the Converter front panel as follows:

WARNING

Dangerous voltages exist inside this unit which could cause loss of life or serious injury.

- a. Loosen the six captive screws on the front panel using a flat tip screwdriver.
- b. Pull the panel out from the Converter chassis and rotate it to the up position.
- c. Ensure that the panel is locked in the up position.

## NOTE

The procedures given in paragraphs 6-2.5 through 6-2.9 are not operational adjustments. These procedures should be performed only by experienced maintenance personnel.

6-2.2. Test Equipment Required (table 1-2).

- a. Oscilloscope and frequency counter.
- b. Distortion generator. (A tape reader or other means of applying reverse keying to send loop may be used.)
- c. Multimeter.

6-2.3. Preliminary Set-Up (table 2-1). Set MODE switch to S/R BTB and KEYING switch to SEND N - RCV N. At external patch frame, patch receive loop and send loop to distortion generator and meter or oscilloscope.

6-2.4. Meter Movement.

- a. Set METER switch to OFF.
- b. Adjust the meter zero-adjust screw (on face of meter) to set pointer on zero ("0" at extreme left of scale).

6-2.5. Receive Bias.

- a. Set POWER switch to ON.
- b. Set METER switch to RCV BIAS.
- c. Set MODE switch to S/R BTB.
- d. Key send dc-data input with reversals.
- e. Adjust BIAS screwdriver adjustable potentiometer (1A6A2R33) (front of component board 1A6) to set front panel meter pointer to BIAS mark.

6-2.6. Send Delay. With a steady mark send data signal applied:

- a. Set MODE switch to FDX; SEND indicator lamp lights.
- b. Set MODE switch to STBY. SEND indicator lamp goes out three seconds later.
- c. Repeat steps 6-2.6a and 6-2.6b, and adjust SEND DELAY screwdriver adjustable potentiometer (1A5A2R7) (front of component board 1A5) until SEND indicator lamp goes out exactly three seconds after MODE switch is set to STBY.

6-2.7. Receive Delay.

- a. Set .75 SEC/3 SEC switch (1A5A2S1)(front of component board 1A5) to 3 SEC.
- b. Set MODE switch to S/R BTB: RECEIVE indicator lamp lights.
- c. Set MODE switch to FDX: RECEIVE indicator lamp goes out three seconds later.
- d. Repeat steps 6-2.7b and 6-2.7c, and adjust RCV DELAY screwdriver adjustment potentiometer (1A5A2R35) (front of component board 1A5) until RECEIVE indicator lamp goes out exactly three seconds after keying is stopped.

6-2.8. Low Band Oscillator Frequencies.

- a. Set FREQ OPTION switch to A and set KEYING switch to SEND R - RCV R.

- b. Connect frequency counter to SEND MONITOR jack.
- c. Remove input from send loop or key with a steady mark.
- d. Adjust 500Hz screwdriver adjustable potentiometer (1A3A2R8) (front of component board 1A3) for 500Hz ( $\pm 2$ Hz) indication on frequency counter.
- e. Set KEYING switch to SEND N - RCV N.
- f. Adjust 700Hz screwdriver adjustable potentiometer (1A3A2R4) (front of component board 1A3) for 700Hz ( $\pm 2$ Hz) indication on frequency counter.

#### 6-2.9. High Band Oscillator Frequencies.

- a. Set FREQ OPTION switch to B and set KEYING switch to SEND R - RCV R.
- b. Connect frequency counter to SEND MONITOR jack.
- c. Remove input from send dc-data input or key with a steady mark.
- d. Adjust 1575Hz screwdriver adjustable potentiometer (1A4A2R8) (front of component board 1A4) for 1575Hz ( $\pm 10$ Hz) indication on frequency counter.
- e. Set KEYING switch to SEND N - RCV N.
- f. Adjust 2425Hz screwdriver adjustable potentiometer (1A4A2R4) (front of component board 1A4) for 2425Hz ( $\pm 15$ Hz) indication frequency counter.

6-3. REPAIR. There are no special repair procedures for the Converter. Repair is accomplished in accordance with standard Navy shop practices.

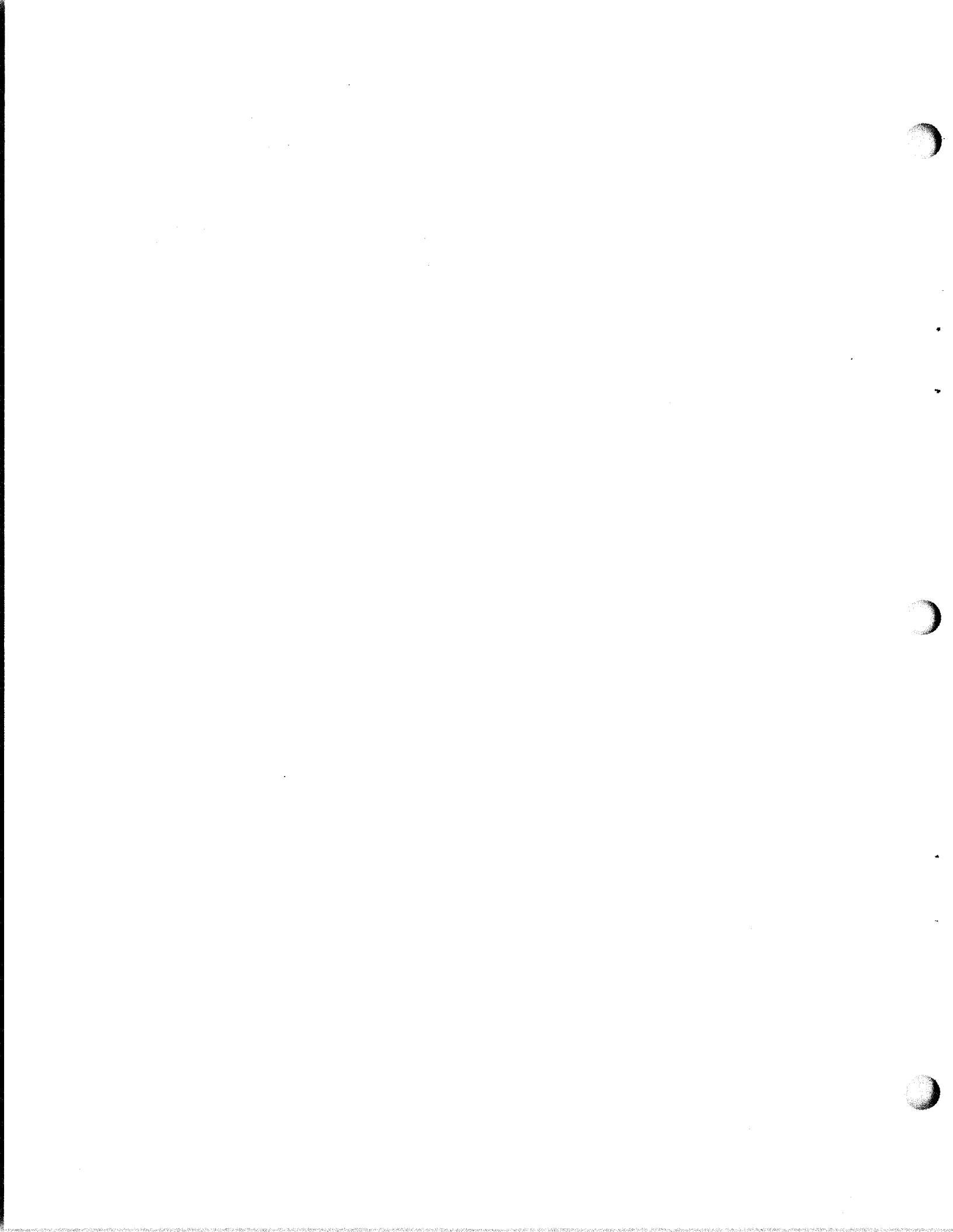



## CHAPTER 7

## PARTS LIST

## 7-1. INTRODUCTION.

a. This parts list chapter includes all pertinent data necessary to locate, identify, and procure additional parts for the Telegraph-Telephone Signal Converter CV-2460/SGC.

b. Parts are listed alphanumerically by reference symbol. A uniform identification method has been used to identify the unit, assemblies, subassemblies, and maintenance parts of the Converter. This method adequately covers several degrees of subdivision of the equipment.

## 7-2. LIST OF MAJOR ASSEMBLIES.

Table 7-1 identifies the major assemblies contained in the Converter. Each major assembly is identified by its reference designation, identification number, and colloquial name. Reference to applicable parts list table is also included.

## 7-3. MAINTENANCE PARTS LIST.

a. Tables 7-2 through 7-12 list main unit, assemblies, and maintenance parts. Maintenance parts for each assembly are listed alphanumerically by Class Of Part, following the assembly designation. Tables 7-2 through 7-12 also provide the following information.

(1) Complete reference designation prefix(es) of each assembly and its colloquial name (appearing at the top of each assembly listing).

(2) Reference designation of each maintenance part.

(3) Name, description, manufacturer's code, and part number.

(4) Identification of illustration that locates the part.

b. Maintenance parts listings for repetitive (identical) assemblies are listed once, with the reference designations at the top of each assembly listing.

## 7-4. LIST OF MANUFACTURERS.

Table 7-13 lists the manufacturers of parts used in the Converter. The table identifies the manufacturer's codes used in Tables 7-2 through 7-12.

Table 7-1. List of Major Assemblies

REF DESIG	PER EQUIP	IDENTIFICATION NUMBER	COLLOQUIAL NAME	TABLE NO.
1	1	90205000-000	Converter	
1A1	1	90205002-000	Power Supply Assembly	7-2
1A2	1	90205008-000	Module Assembly, Send and Input	7-3
1A3	1	90205009-000	Module Assembly, Send Osc A	7-4
1A4	1	90205010-000	Module Assembly, Send Osc B	7-5
1A5	1	90205011-000	Module Assembly, Control	7-6
1A6	1	90205012-000	Module Assembly, Receive	7-7
1A7	1	80205060-000	Component Board Assembly, Output Keying	7-8
1A8	1	80205080-001	Component Board Assembly, Rcv Fltr Lo-Band	7-9
1A9	1	80205080-002	Component Board Assembly, Rcv Fltr Hi-Band	7-10
1A10	1	80205070-000	Component Board Assembly, Test PC	7-11
1A11	1	90205001-000	Chassis Assembly	7-12

Table 7-2. Maintenance Parts List for Module 1A1

REF DESIG	NOTES	NAME AND DESCRIPTION	FIGURE NUMBER
1A1		POWER SUPPLY ASSEMBLY: Provides all secondary power required to operate the Converter, except the loop battery; mfr 96238, dwg 90205002-000.	5-4
1A1C1		CAPACITOR, FIXED ELECTROLYTIC: 470 uF, 50 WVDC; MIL Type CE41C471G.	5-4
1A1C2		NOT USED	
1A1C3		CAPACITOR, FIXED ELECTROLYTIC: 470 uF, 50 WVDC; MIL Type CE41C471G.	5-4
1A1C4 and 1A1C5		CAPACITOR, FIXED, PAPER: 0.1 uF, 400 WVDC: MIL Type CZ24BEE104.	5-4
1A1Q1		TRANSISTOR: MIL Type 2N297A.	5-4
1A1T1		TRANSFORMER, POWER: mfr 96238, dwg 43000246-000.	5-4
1A1A1		COMPONENT BOARD ASSEMBLY; POWER SUPPLY: Printed component board with all components assembled, ready for operation; mfr 96238, dwg 80205190-000.	5-4
1A1A1C1		NOT USED	
1A1A1C2		CAPACITOR, FIXED, ELECTROLYTIC: 68 uF, 50 WVDC; MIL Type CE13C680G.	5-4
1A1A1CR1 thru 1A1A1CR4		SEMICONDUCTOR, DIODE: MIL Type 1N3189.	5-4
1A1A1R1		RESISTOR, FIXED, WW: 3.3 ohms, 5%, 3W, MIL Type RW69V3R3.	5-4
1A1A1R2 and 1A1A1R3		RESISTOR, FIXED, COMPOSITION: 680 ohms 5%, 1W; MIL Type RC32GF681J.	5-4
1A1A1R4		RESISTOR, FIXED, FILM: 30.1k ohms, 1%, 1W; MIL Type RN60D3012F.	5-4
1A1A1R5		RESISTOR, FIXED, COMPOSITION: 2.2k ohms, 5%, 1/2W; MIL Type RC20GF222J.	5-4
1A1A1R6		RESISTOR, FIXED, COMPOSITION: 174 ohms, 1%, 1W; MIL Type RN60D1740F.	5-4

Table 7-2. Maintenance Parts List for Module 1A1 (Continued)

REF DESIG	NOTES	NAME AND DESCRIPTION	FIGURE NUMBER
1A1A1R7 and 1A1A1R8 1A1A1VR1		RESISTOR, FIXED, COMPOSITION: 160 ohms, 5%, 1W; MIL Type RC32GF161J.	5-4
1A1A1VR2		SEMICONDUCTOR DIODE, ZENER: MIL Type 1N3029B.	5-4
		SEMICONDUCTOR DIODE, ZENER: MIL Type 1N758A.	5-4
1A1A2	1	TEST EXTENDER, POWER SUPPLY: with all components assembled for operation; mfr 96238, dwg 90205013-000.	
1A1A2J1	1	CONNECTOR, RECEPTACLE, ELECTRICAL: mfr 71785, dwg 250-10-37-220.	
1A1A2R1	1	RESISTOR, FIXED, WW: 75 ohms, 5%, 10W; mfr 17745, dwg 10XMT5.	
1A1A2W1	1	CABLE ASSEMBLY, POWER: mfr 96238, dwg 74000060-000.	

1. Not illustrated.

TABLE 7-3. Maintenance Parts List for Module 1A2

REF DESIG	NOTES	NAME AND DESCRIPTION	FIGURE NUMBER
1A2		MODULE ASSEMBLY, SEND AND INPUT: Converts a dc-data signal to a frequency shift tone-data signal; mfr 96238, dwg 90205008-000.	5-8
1A2A1		COMPONENT BOARD ASSEMBLY, SEND AND INPUT: Printed component board with all components assembled, ready for operation; mfr 96238, dwg 80205010-000.	5-8
1A2A1C1 and 1A2A1C2 1A2A1C3		CAPACITOR, FIXED ELECTROLYTIC: 0.47 uF; MIL Type CS13BF474K.	5-8
1A2A1C4		CAPACITOR, FIXED, MICA: 3000 pF, MIL Type CM06FD302J03.	5-8
1A2A1C5 and 1A2A1C6 1A2A1C7		CAPACITOR, FIXED, MICA: 1000 pF, MIL Type CM06FD102J03.	5-8
1A2A1C8		CAPACITOR, FIXED, PAPER: 0.01 uF, MIL Type CP05A1KE103K3.	5-8
1A2A1C9		CAPACITOR, FIXED, ELECTROLYTIC: 10 uF; MIL Type CS13BF106K.	5-8
1A2A1C10		CAPACITOR, FIXED, ELECTROLYTIC: 1.0 uF; MIL Type CS13BF105K.	5-8
1A2A1C11 thru 1A2A1C13		CAPACITOR, FIXED, CERAMIC: 0.0082 uF; MIL Type CK62AW822M.	5-8
1A2A1L1 and 1A2A1L2		SEMICONDUCTOR, DIODE: MIL Type 1N4148.	5-8
1A2A1Q1		INDUCTOR: 2.2 mH; MIL Type MS90537-53.	5-8
1A2A1Q2		TRANSISTOR, NPN: MIL Type 2N1613.	5-8
1A2A1Q3 thru 1A2A1Q9		TRANSISTOR, PNP: MIL Type 2N2905.	5-8
1A2A1R1		TRANSISTOR, NPN: MIL Type 2N1613.	5-8
		RESISTOR, FIXED, COMPOSITION: 10k ohms, 1/2 W, 5%, MIL Type RC20GF103J.	5-8

Table 7-3. Maintenance Parts List for Module 1A2 (Continued)

REF DESIG	NOTES	NAME AND DESCRIPTION	FIGURE NUMBER
1A2A1R2		RESISTOR, FIXED, COMPOSITION: 330k ohms, 1/2 W, 5%, MIL Type RC20GF334J.	5-8
1A2A1R3		RESISTOR, FIXED, COMPOSITION: 4.7k ohms, 1/2 W, 5%, MIL Type RC20GF472J.	5-8
1A2A1R4		RESISTOR, FIXED, COMPOSITION: 3.3k ohms, 1/2 W, 5%, MIL Type RC20GF332J.	5-8
1A2A1R5		RESISTOR, FIXED, COMPOSITION: 200 ohms, 1/2 W, 5%, MIL Type RC20GF201J.	5-8
1A2A1R6		RESISTOR, FIXED, COMPOSITION: 1k ohms, 1/2 W, 5%, MIL Type RC20GF102J.	5-8
1A2A1R7		RESISTOR, FIXED, COMPOSITION: 39 ohms, 1/2W, 5%, MIL Type RC20GF390J.	5-8
1A2A1R8		RESISTOR, FIXED, COMPOSITION: 150 ohms, 1/2W, 5%, MIL Type RC20GF151J.	5-8
1A2A1R9		RESISTOR, FIXED, COMPOSITION: 470 ohms, 1/2 W, 5%, MIL Type RC20GF471J.	5-8
1A2A1R10		RESISTOR, FIXED, COMPOSITION: 15k ohms, 1/2 W, 5%, MIL Type RC20GF153J.	5-8
1A2A1R11		RESISTOR, FIXED, COMPOSITION: 560 ohms, 1/2 W, 5%, MIL Type RC20GF561J.	5-8
1A2A1R12		RESISTOR, FIXED, FILM: 6.34k ohms, 1/2 W, 1%, MIL Type RN70D6341F.	5-8
1A2A1R13		RESISTOR, FIXED, COMPOSITION: 2k ohms, 1/2 W, 5%, MIL Type RC20GF202J.	5-8
1A2A1R14		RESISTOR, FIXED, COMPOSITION: 2k ohms, 1/2 W, 5%, MIL Type RC20GF202J.	5-8
1A2A1R15		RESISTOR, FIXED, COMPOSITION: 56k ohms, 1/2 W, 5%, MIL Type RC20GF563J.	5-8
1A2A1R16		RESISTOR, FIXED, COMPOSITION: 43 ohms, 1/2 W, 5%, RC20GF430J.	5-8
1A2A1R17		RESISTOR, COMPOSITION: 10k ohms, 1/2 W, 5%, MIL Type RC20GF103J.	5-8
1A2A1R18		RESISTOR, COMPOSITION: 4.7k ohms, 1/2 W, 5%, MIL Type RC20GF472J.	5-8
1A2A1R19		RESISTOR, FIXED, COMPOSITION: 56k ohms, 1/2 W, 5%, MIL Type RC20GF563J.	5-8
1A2A1R20		RESISTOR, COMPOSITION: 10k ohms, 1/2 W, 5%, MIL Type RC20GF103J.	5-8
1A2A1R21		RESISTOR, COMPOSITION: 4.7k ohms, 1/2 W, 5%, MIL Type RC20GF472J.	5-8

Table 7-3. Maintenance Parts List for Module 1A2 (Continued)

REF DESIG	NOTES	NAME AND DESCRIPTION	FIGURE NUMBER
1A2A1R22		RESISTOR, FIXED, COMPOSITION: 10 ohms 1/2 W, 5%, MIL Type RC20GF100J.	5-8
1A2A1R23		RESISTOR, FIXED, COMPOSITION: 150 ohms, 1/2W, 5%, MIL Type RC20GF151J.	5-8
1A2A1R24		RESISTOR, FIXED, COMPOSITION: 62k ohms, 1/2 W, 5%, MIL Type RC20GF623J.	5-8
1A2A1R25		RESISTOR, COMPOSITION: 10k ohms, 1/2 W, 5%, MIL Type RC20GF103J.	5-8
1A2A1R26		RESISTOR, FIXED, COMPOSITION: 20k ohms, 1/2 W, 5%, MIL Type RC20GF203J.	5-8
1A2A1R27		RESISTOR, COMPOSITION: 4.7k ohms, 1/2 W, 5%, MIL Type RC20GF472J.	5-8
1A2A1R28		RESISTOR, FIXED, COMPOSITION: 750 ohms, 1/2 W, 5%, MIL Type RC20GF751J.	5-8
1A2A1R29		RESISTOR, FIXED, COMPOSITION: 120k ohms, 1/2 W, 5%, MIL Type RC20GF124J.	5-8
1A2A1R30		RESISTOR, FIXED, COMPOSITION: 75 ohms, 1/2 W, 5%, MIL Type RC20GF750J.	5-8
1A2A1R31		RESISTOR, FIXED, COMPOSITION: 470 ohms, 1 W, 5%, MIL Type RC20GF471J.	5-8
1A2A1R32		RESISTOR, FIXED, COMPOSITION: 100 ohms, 1/2 W, 5%, MIL Type RC20GF101J.	5-8
1A2A1R33		NOT USED.	
1A2A1R34		RESISTOR, FIXED, COMPOSITION: 3.3k ohms, 1/2 W, 5%, MIL Type RC20GF332J.	5-8
1A2A1R35		RESISTOR, FIXED, COMPOSITION: 1k ohms, 1/2 W, 5%, MIL Type RC20GF102J.	5-8
1A2A1R36		RESISTOR, FIXED, FILM: 4.3k ohms, 1/2 W, 1%, MIL Type RN70B4301F.	5-8
1A2A1T1		TRANSFORMER, Pulse: Mfr 96238, dwg 43003040-000.	5-8
1A2A1T2		TRANSFORMER, AF: Mfr 96238, dwg 43001139-000.	5-8
1A2A1VR1		SEMICONDUCTOR, DIODE ZENER: MIL Type 1N3020B.	5-8
1A2A2		FRONT PANEL ASSEMBLY, SEND AND INPUT: Consists of a panel and components which mounts and supplies part of circuitry for the SEND AND INPUT MODULE ASSEMBLY; mfr 96238, dwg 90205004-000.	5-8

Table 7-3. Maintenance Parts List for Module 1A2 (Continued)

REF DESIG	NOTES	NAME AND DESCRIPTION	FIGURE NUMBER
1A2A2R1 thru 1A2A2R32 1A2A2R33		NOT USED	5-8
1A2A2S1		RESISTOR; VARIABLE: 10k ohms, MIL Type RV6LAYS103C. SWITCH, TOGGLE: MIL Type MS75028-23.	5-8



Table 7-4. Maintenance Parts List for Module 1A3

REF DESIG	NOTES	NAME AND DESCRIPTION	FIGURE NUMBER
1A3		MODULE ASSEMBLY, LOW BAND SEND OSC "A": Frequency shift oscillator; mfr 96238, dwg 90205009-000.	5-10
1A3A1		COMPONENT BOARD ASSEMBLY, LOW BAND: Printed component board with all com- ponents assembled ready for operation; mfr 96238, dwg 80205020-001.	5-10
1A3A1C1		CAPACITOR, FIXED, PLASTIC: 0.0047 uF; MIL Type CQ09A1PC472G3.	5-10
1A3A1C2		CAPACITOR, FIXED, MICA: 0.0051 uF, MIL Type CM35FD512GN3.	5-10
1A3A1C3		CAPACITOR, FIXED, MICA: 56 to 360 pF, parm 5%, 500 WVDC (SELECT AT TEST), MIL Type CM05-----J03.	5-10
1A3A1C4 thru 1A3A1C6 1A3A1C7 thru 1A3A1C8 1A3A1CR1 and 1A3A1CR2 1A3A1FL1		CAPACITOR, FIXED, MICA: 0.001 uF, MIL Type CM06FD102J03.	5-10
		CAPACITOR, FIXED, ELECTROLYTIC: 22 uF, 35 WVDC; MIL Type CS13BF226K.	5-10
		SEMICONDUCTOR, DIODE: MIL Type 1N4148.	5-10
		FILTER, LOW PASS: Mfr 96238, dwg 43020140-000.	5-10
1A3A1Q1		TRANSISTOR, NPN: MIL Type 2N1613.	5-10
1A3A1Q2		TRANSISTOR, UNIJUNCTION, P-TYPE: Mfr 03508, dwg D5K1.	5-10
1A3A1Q3 thru 1A3A1Q7 1A3A1R1		TRANSISTOR, NPN: MIL Type 2N1613.	5-10
		RESISTOR, FIXED, COMPOSITION: 47k ohms, 1/2 W, 5%, MIL Type RC20GF473J.	5-10
1A3A1R2		RESISTOR, FIXED, COMPOSITION: 10k ohms, 1/2 W, 5%, MIL Type RC20GF103J.	5-10
1A3A1R3		RESISTOR, FIXED, FILM: 291k ohms, 1/4W, 1%, MIL Type RN65C2913F.	5-10
1A3A1R4		NOT USED.	

Table 7-4. Maintenance Parts List for Module 1A3 (Continued)

REF DESIG	NOTES	NAME AND DESCRIPTION	FIGURE NUMBER
1A3A1R5		RESISTOR, FIXED, COMPOSITION: 47 ohms, 1/2 W, 5%, MIL Type RC20GF470J.	5-10
1A3A1R6		RESISTOR, FIXED, FILM: 124k ohms, 1/4W, 1%, MIL Type RN65C1243F.	5-10
1A3A1R7		RESISTOR, FIXED, COMPOSITION: 680 ohms, 1/2 W, 5%, MIL Type RC20GF681J.	5-10
1A3A1R8		NOT USED.	
1A3A1R9		RESISTOR, FIXED, COMPOSITION: 10k ohms, 1/2 W, 5%, MIL Type RC20GF103J.	5-10
1A3A1R10		RESISTOR, FIXED, COMPOSITION: 5.6k ohms, 1/2 W, 5%, MIL Type RC20GF562J.	5-10
1A3A1R11		RESISTOR, FIXED, COMPOSITION: 2.2k ohms, 1/2 W, 5%, MIL Type RC20GF222J.	5-10
1A3A1R12		RESISTOR, FIXED, COMPOSITION: 10k ohms, 1/2 W, 5%, MIL Type RC20GF103J.	5-10
1A3A1R13		RESISTOR, FIXED, COMPOSITION: 56k ohms, 1/2 W, 5%, MIL Type RC20GF563J.	5-10
1A3A1R14		RESISTOR, FIXED, COMPOSITION: 5.6k ohms, 1/2 W, 5%, MIL Type RC20GF562J.	5-10
1A3A1R15		RESISTOR, FIXED, COMPOSITION: 15k ohms, 1/2 W, 5%, MIL Type RC20GF153J.	5-10
1A3A1R16		RESISTOR, FIXED, COMPOSITION: 82k ohms, 1/2 W, 5%, MIL Type RC20GF823J.	5-10
1A3A1R17		RESISTOR, FIXED, COMPOSITION: 5.6k ohms, 1/2 W, 5%, MIL Type RC20GF562J.	5-10
1A3A1R18		RESISTOR, FIXED, COMPOSITION: 5.6k ohms, 1/2 W, 5%, MIL Type RC20GF562J.	5-10
1A3A1R19		RESISTOR, FIXED, COMPOSITION: 15k ohms, 1/2 W, 5%, MIL Type RC20GF153J.	5-10
1A3A1R20		RESISTOR, FIXED, COMPOSITION: 82k ohms, 1/2 W, 5%, MIL Type RC20GF823J.	5-10
1A3A1R21		RESISTOR, FIXED, COMPOSITION: 5.6k ohms, 1/2 W, 5%, MIL Type RC20GF562J.	5-10
1A3A1R22		RESISTOR, FIXED, COMPOSITION: 15k ohms, 1/2 W, 5%, MIL Type RC20GF153J.	5-10
1A3A1R23		RESISTOR, FIXED, COMPOSITION: 150 ohms, 1/2W, 5%, MIL Type RC20GF151J.	5-10
1A3A1R24		RESISTOR, FIXED, COMPOSITION: 270 ohms, 1/2 W, 5%, MIL Type RC20GF271J.	5-10
1A3A1R25		RESISTOR, FIXED, COMPOSITION: 1.3k ohms, 1/2 W, 5%, MIL Type RC20GF132J.	5-10

Table 7-4. Maintenance Parts List for Module 1A3 (Continued)

REF DESIG	NOTES	NAME AND DESCRIPTION	FIGURE NUMBER
1A3A1R26		RESISTOR, FIXED, COMPOSITION: 1.1k ohms, 1/2 W, 5%, MIL Type RC20GF112J.	5-10
1A3A1R27		RESISTOR, FIXED, COMPOSITION: 750 ohms, 1/2 W, 5%, MIL Type RC20GF751J.	5-10
1A3A1VR1		SEMICONDUCTOR, DIODE, ZENER: MIL Type 1N963B.	5-10
1A3A2		FRONT PANEL ASSEMBLY, SEND OSC "A": Consists of a panel and components which mounts and supplies part of the circuitry for the SEND OSC "A" Module; mfr 96238, dwg 90205005-000.	5-10
1A3A2R1 thru 1A3A2R3 1A3A2R4		NOT USED.	
1A3A2R5 thru 1A3A2R7 1A3A2R8		RESISTOR, VARIABLE: 25k ohms; MIL Type RV6LAYS253A. NOT USED.	5-10
		RESISTOR, VARIABLE: 250 ohms; MIL Type RV6LAYS251A.	5-10

Table 7-5. Maintenance Parts List for Module 1A4

REF DESIG	NOTES	NAME AND DESCRIPTION	FIGURE NUMBER
1A4		MODULE ASSEMBLY, HIGH BAND, SEND OSC "B": Frequency shift oscillator; mfr 96238, dwg 90205010-000.	5-10
1A4A1		COMPONENT BOARD ASSEMBLY, HIGH BAND, SEND OSC "B": Printed component board with all components assembled, ready for operation; mfr 96238, dwg 80205020-002.	5-10
1A4A1C1		CAPACITOR, FIXED, PLASTIC: 0.0022 $\mu$ F; MIL Type CQ09A1PC222G3.	5-10
1A4A1C2		CAPACITOR, FIXED, MICA: 750 pF; MIL Type CM06FD751GN3.	5-10
1A4A1C3		CAPACITOR, FIXED, MICA: 0 to 300 pF; parm 5%, 500 WVDC; (SELECT AT TEST) MIL Type CM05-----.	5-10
1A4A1C4 thru 1A4A1C6 1A4A1C7 and 1A4A1C8 1A4A1CR1 and 1A4A1CR2 1A4A1FL1		CAPACITOR, FIXED, MICA: 0.001 $\mu$ F; MIL Type CM06FD102J03.	5-10
		CAPACITOR, FIXED, ELECTROLYTIC: 22 $\mu$ F, 35 WVDC; MIL Type CS13BF226K.	5-10
		SEMICONDUCTOR, DIODE: MIL Type 1N4148.	5-10
		FILTER, LOW PASS: Mfr 96238, dwg 43020141-000.	5-10
1A4A1Q1		TRANSISTOR, NPN: MIL Type 2N1613.	5-10
1A4A1Q2		TRANSISTOR, UNIJUNCTION: P-TYPE: Mfr 03508, dwg D5K1.	5-10
1A4A1Q3 thru 1A4A1Q7 1A4A1R1		TRANSISTOR, NPN: MIL Type 2N1613.	5-10
		RESISTOR, FIXED, COMPOSITION: 47k ohms; 1/2 W, 5%, MIL Type RC20GF473J.	5-10
1A4A1R2		RESISTOR, FIXED, COMPOSITION: 10k ohms; 1/4 W, 5%, MIL Type RN65C103J.	5-10
1A4A1R3		RESISTOR, FIXED, FILM: 215k ohms, 1/4 W, 1%, MIL Type RN65C2153F.	5-10
1A4A1R4		NOT USED.	

Table 7-5. Maintenance Parts List for Module 1A4 (Continued)

REF DESIG	NOTES	NAME AND DESCRIPTION	FIGURE NUMBER
1A4A1R5		RESISTOR, FIXED, COMPOSITION: 47 ohms, 1/2 W, 5%, MIL Type RC20GF470J.	5-10
1A4A1R6		RESISTOR, FIXED, COMPOSITION: 124k ohms, 1/4 W, 1%, MIL Type RN65C1243F.	5-10
1A4A1R7		RESISTOR, FIXED, COMPOSITION: 680 ohms, 1/2 W, 5%, MIL Type RC20GF681J.	5-10
1A4A1R8		NOT USED.	
1A4A1R9		RESISTOR, FIXED, COMPOSITION: 10k ohms; 1/4 W, 5%, MIL Type RN65C103J.	5-10
1A4A1R10		RESISTOR, FIXED, COMPOSITION: 5.6k ohms, 1/2 W, 5%, MIL Type RC20GF562J.	5-10
1A4A1R11		RESISTOR, FIXED, COMPOSITION: 2.2k ohms, 1/2W, 5%, MIL Type RC20GF222J.	5-10
1A4A1R12		RESISTOR, FIXED, COMPOSITION: 10k ohms; 1/4 W, 5%, MIL Type RN65C103J.	5-10
1A4A1R13		RESISTOR, FIXED, COMPOSITION: 56k ohms, 1/2 W, 5%; MIL Type RC20GF563J.	5-10
1A4A1R14		RESISTOR, FIXED, COMPOSITION: 5.6k ohms, 1/2 W, 5%, MIL Type RC20GF562J.	5-10
1A4A1R15		RESISTOR, FIXED, COMPOSITION: 15k ohms, 1/2 W, 5%; MIL Type RC20GF153J.	5-10
1A4A1R16		RESISTOR, FIXED, COMPOSITION: 82k ohms, 1/2 W, 5%; MIL Type RC20GF823J.	5-10
1A4A1R17		RESISTOR, FIXED, COMPOSITION: 5.6k ohms, 1/2 W, 5%, MIL Type RC20GF562J.	5-10
1A4A1R18		RESISTOR, FIXED, COMPOSITION: 5.6k ohms,	5-10
1A4A1R19		RESISTOR, FIXED, COMPOSITION: 15k ohms, 1/2 W, 5%; MIL Type RC20GF153J.	5-10
1A4A1R20		RESISTOR, FIXED, COMPOSITION: 82k ohms, 1/2 W, 5%; MIL Type RC20GF823J.	5-10
1A4A1R21		RESISTOR, FIXED, COMPOSITION: 5.6k ohms, 1/2 W, 5%, MIL Type RC20GF562J.	5-10
1A4A1R22		RESISTOR, FIXED, COMPOSITION: 15k ohms, 1/2 W, 5%; MIL Type RC20GF153J.	5-10
1A4A1R23		RESISTOR, FIXED, COMPOSITION: 150 ohms, 1/2 W, 5%; MIL Type RC20GF151J.	5-10
1A4A1R24		RESISTOR, FIXED, COMPOSITION: 270 ohms, 1/2W, 5%; MIL Type RC20GF271J.	5-10
1A4A1R25		RESISTOR, FIXED, COMPOSITION: 1.3k ohms, 1/2 W, 5%; MIL Type RC20GF132J.	5-10

Table 7-5. Maintenance Parts List for Module 1A4 (Continued)

REF DESIG	NOTES	NAME AND DESCRIPTION	FIGURE NUMBER
1A4A1R26		RESISTOR, FIXED, COMPOSITION: 1.1k ohms, 1/2 W, 5%, MIL Type RC20GF112J.	5-10
1A4A1R27		RESISTOR, FIXED, COMPOSITION: 750 ohms, 1/2 W, 5%; MIL Type RC20GF751J.	5-10
1A4A1VR1		SEMICONDUCTOR, DIODE, ZENER: MIL Type 1N963B.	5-10
1A4A2		FRONT PANEL ASSEMBLY, SEND OSC "B": Consists of a panel and components which mounts and supplies part of the circuitry for the SEND OSC "B" Module; mfr 96238, dwg 90205005-001.	5-10
1A4A2R1 thru 1A4A2R3 1A4A2R4		NOT USED.	
1A4A2R5 thru 1A4A2R7 1A4A2R8		RESISTOR, VARIABLE: 25k ohms, 1/2W, 5%, MIL Type RV6LAYS253A. NOT USED.	5-10
		RESISTOR, VARIABLE: 250 ohms, 1/2W, 5%; MIL Type RV6LAYS251A.	5-10

Table 7-6. Maintenance Parts List for Module 1A5

REF DESIG	NOTES	NAME AND DESCRIPTION	FIGURE NUMBER
1A5		MODULE ASSEMBLY, CONTROL: Conditions the send and receive sections to operate in send, receive, full duplex, or half duplex mode; mfr 96238, dwg 90205011-000.	5-12
1A5A1		COMPONENT BOARD ASSEMBLY, CONTROL: Printed component board with all components assembled, ready for operation; mfr 96238, dwg 80205040-000.	5-12
1A5A1C1 and 1A5A1C2 1A5A1C3		CAPACITOR, FIXED, ELECTROLYTIC: 22 $\mu$ F; MIL Type CS13BF226K.	5-12
1A5A1C4		CAPACITOR, FIXED, ELECTROLYTIC: 1.0 $\mu$ F; MIL Type CS13BF105K.	5-12
1A5A1C5		CAPACITOR, FIXED, MICA: 0.001 $\mu$ F; MIL Type CM06FD102J03.	5-12
1A5A1C6 thru 1A5A1C11 1A5A1C12 and 1A5A1C13 1A5A1C14		CAPACITOR, FIXED, MICA: 0.003 $\mu$ F, MIL Type CM06FD302J03.	5-12
1A5A1C15		CAPACITOR, FIXED, PAPER: 0.1 $\mu$ F; MIL Type CP05A1KB104K3.	5-12
1A5A1C16		CAPACITOR, FIXED, ELECTROLYTIC: 1.0 $\mu$ F; MIL Type CS13BF105K.	5-12
1A5A1CR1 thru 1A5A1CR8 1A5A1CR9 thru 1A5A1CR12 1A5A1CR13 thru 1A5A1CR18		CAPACITOR, FIXED, ELECTROLYTIC: 0.33 $\mu$ F, 50 WVDC; MIL Type CSR13G334KL.	5-12
		CAPACITOR, FIXED, CERAMIC: 0.0082 $\mu$ F; MIL Type CK62AW822M.	5-12
		CAPACITOR, FIXED, CERAMIC: 0.01 $\mu$ F; 500 WVDC; MIL Type CK63AW103M.	5-12
		SEMICONDUCTOR, DIODE: MIL Type 1N4148.	5-12
		SEMICONDUCTOR, DIODE: MIL Type 1N645.	5-12
		SEMICONDUCTOR, DIODE: MIL Type 1N4148.	5-12

Table 7-6. Maintenance Parts List for Module 1A5 (Continued)

REF DESIG	NOTES	NAME AND DESCRIPTION	FIGURE NUMBER
1A5A1L1 and 1A5A1L2		INDUCTOR: 2.2 mH; MIL Type MS90537-53.	5-12
1A5A1Q1 thru 1A5A1Q9		TRANSISTOR, NPN: MIL Type 2N1613.	5-12
1A5A1Q10		TRANSISTOR, PNP: MIL Type 2N2905.	5-12
1A5A1Q11		TRANSISTOR, NPN: MIL Type 2N1613.	5-12
1A5A1Q12		TRANSISTOR, ELECTRONIC SWITCH: Mfr 96238, dwg 40001201-001.	5-12
1A5A1Q13 and 1A5A1Q14		TRANSISTOR, NPN: MIL Type 2N1613.	5-12
1A5A1R1		RESISTOR, FIXED, COMPOSITION: 10k ohms, 1/2 W, 5%; MIL Type RC20GF103J.	5-12
1A5A1R2		RESISTOR, FIXED, COMPOSITION: 150 ohms, 1/2 W, 5%; MIL Type RC20GF151J.	5-12
1A5A1R3		RESISTOR, FIXED, COMPOSITION: 510 ohms, 1/2 W, 5%; MIL Type RC20GF511J.	5-12
1A5A1R4		RESISTOR, FIXED, COMPOSITION: 10k ohms, 1/2 W, 5%; MIL Type RC20GF103J.	5-12
1A5A1R5		RESISTOR, FIXED, COMPOSITION: 2.7k ohms, 1/2 W, 5%; MIL Type RC20GF272J.	5-12
1A5A1R6		RESISTOR, FIXED, COMPOSITION: 100k ohms, 1/2 W, 5%; MIL Type RC20GF104J.	5-12
1A5A1R7		NOT USED.	
1A5A1R8		RESISTOR, FIXED, COMPOSITION: 4.7k ohms, 1/2 W, 5%; MIL Type RC20GF472J.	5-12
1A5A1R9		RESISTOR, FIXED, COMPOSITION: 3.3k ohms, 1/2 W, 5%; MIL Type RC20GF332J.	5-12
1A5A1R10		NOT USED.	
1A5A1R11 thru 1A5A1R14		RESISTOR, FIXED, COMPOSITION: 10k ohms, 1/2 W, 5%; MIL Type RC20GF103J.	5-12
1A5A1R15		RESISTOR, FIXED, COMPOSITION: 33 ohms, 1/2 W, 5%; MIL Type RC20GF330J.	5-12
1A5A1R16 and 1A5A1R17		RESISTOR, FIXED, COMPOSITION: 4.7k ohms, 1/2 W, 5%; MIL Type RC20GF472J.	5-12
1A5A1R18		RESISTOR, FIXED, COMPOSITION: 27k ohms, 1/2 W, 5%; MIL Type RC20GF273J.	5-12



Table 7-6. Maintenance Parts List for Module 1A5 (Continued)

REF DESIG	NOTES	NAME AND DESCRIPTION	FIGURE NUMBER
1A5A1R19		RESISTOR, FIXED, COMPOSITION: 4.7k ohms, 1/2 W, 5%; MIL Type RC20GF472J.	5-12
1A5A1R20		RESISTOR, FIXED, COMPOSITION: 15k ohms, 1/2w, 5%; MIL Type RC20GF153J.	5-12
1A5A1R21		RESISTOR, FIXED, COMPOSITION: 150 ohms, 1/2 W, 5%; MIL Type RC20GF151J.	5-12
1A5A1R22		RESISTOR, FIXED, COMPOSITION: 510 ohms, 1/2 W, 5%; MIL Type RC20GF511J.	5-12
1A5A1R23		RESISTOR, FIXED, COMPOSITION: 3.3k ohms, 1/2 W, 5%; MIL Type RC20GF332J.	5-12
1A5A1R24		RESISTOR, FIXED, COMPOSITION: 2.7k ohms, 1/2 W, 5%; MIL Type RC20GF272J.	5-12
1A5A1R25		RESISTOR, FIXED, COMPOSITION: 100k ohms, 1/2 W, 5%; MIL Type RC20GF104J.	5-12
1A5A1R26		RESISTOR, FIXED, COMPOSITION: 150 ohms, 1/2 W, 5%; MIL Type RC20GF151J.	5-12
1A5A1R27		RESISTOR, FIXED, COMPOSITION: 4.7k ohms, 1/2 W, 5%; MIL Type RC20GF472J.	5-12
1A5A1R28		RESISTOR, FIXED, COMPOSITION: 3.3k ohms, 1/2 W, 5%; MIL Type RC20GF332J.	5-12
1A5A1R29		RESISTOR, FIXED, COMPOSITION: 10k ohms, 1/2 W, 5%; MIL Type RC20GF103J.	5-12
1A5A1R30		RESISTOR, FIXED, COMPOSITION: 27 ohms, 1/2 W, 5%; MIL Type RC20GF270J.	5-12
1A5A1R31		RESISTOR, FIXED, COMPOSITION: 15k ohms, 1/2W, 5%; MIL Type RC20GF153J.	5-12
1A5A1R32		RESISTOR, FIXED, COMPOSITION: 6.8k ohms, 1/2 W, 5%; MIL Type RC20GF682J.	5-12
1A5A1R33		RESISTOR, FIXED, COMPOSITION: 33 ohms, 1/2 W, 5%; MIL Type RC20GF330J.	5-12
1A5A1R34		RESISTOR, FIXED, COMPOSITION: 4.7k ohms, 1/2 W, 5%; MIL Type RC20GF472J.	5-12
1A5A1R35		NOT USED.	
1A5A1R36		RESISTOR, FIXED, COMPOSITION: 4.7k ohms, 1/2 W, 5%; MIL Type RC20GF472J.	5-12
1A5A1R37		RESISTOR, FIXED, COMPOSITION: 3.3k ohms, 1/2 W, 5%; MIL Type RC20GF332J.	5-12
1A5A1R38		RESISTOR, FIXED, COMPOSITION: 510 ohms, 1/2 W, 5%; MIL Type RC20GF511J.	5-12
1A5A1R39		RESISTOR, FIXED, COMPOSITION: 15k ohms, 1/2W, 5%; MIL Type RC20GF153J.	5-12

Table 7-6. Maintenance Parts List for Module 1A5 (Continued)

REF DESIG	NOTES	NAME AND DESCRIPTION	FIGURE NUMBER
1A5A1R40		RESISTOR, FIXED, COMPOSITION: 510 ohms, 1/2 W, 5%; MIL Type RC20GF511J.	5-12
1A5A1R41		RESISTOR, FIXED, COMPOSITION: 2.7k ohms, 1/2 W, 5%; MIL Type RC20GF272J.	5-12
1A5A1R42 thru 1A5A1R44 1A5A1R45		RESISTOR, FIXED, COMPOSITION: 22k ohms, 1/2 W, 5%; MIL Type RC20GF223J.	5-12
1A5A1R46 thru 1A5A1R48 1A5A1R49		RESISTOR, FIXED, COMPOSITION: 33k ohms, 1/2 W, 5%; MIL Type RC20GF333J.	5-12
1A5A1T1		RESISTOR, FIXED, COMPOSITION: 22k ohms, 1/2 W, 5%; MIL Type RC20GF223J.	5-12
1A5A2		RESISTOR, FIXED, COMPOSITION: 10k ohms, 1/2 W, 5%; MIL Type RC20GF103J.	5-12
1A5A2R1 thru 1A5A2R6 1A5A2R7		TRANSFORMER, PULSE: Mfr 96238, dwg 43003040-000.	5-12
1A5A2R8 thru 1A5A2R34 1A5A2R35		FRONT PANEL ASSEMBLY, CONTROL: Consists of a panel and components which mounts and supplies part of the circuitry of Control Module Assembly; mfr 96238, dwg 90205006-000.	5-12
1A5A2S1		NOT USED.	
		RESISTOR, VARIABLE, 100k ohms, 1/2W, 5%; MIL Type RV6LAYS104A.	5-12
		NOT USED.	
		RESISTOR, VARIABLE, 100k ohms, 1/2W, 5%; MIL Type RV6LAYS104A.	5-12
		SWITCH, TOGGLE: MIL Type MS75028-22.	5-12

Table 7-7. Maintenance Parts List for Module 1A6

REF DESIG	NOTES	NAME AND DESCRIPTION	FIGURE NUMBER
1A6		MODULE ASSEMBLY, RECEIVE: Converts tone data signal to dc-data signal; mfr 96238, dwg 90205012-000.	5-14
1A6A1		COMPONENT BOARD, ASSEMBLY, RECEIVE: Printed component board with all components assembled ready for operation; mfr 96238, dwg 80205050-000.	5-14
1A6A1C1 and 1A6A1C2 1A6A1C3		CAPACITOR, FIXED, ELECTROLYTIC: 1.0 uF; MIL Type CS13BF105K.	5-14
1A6A1C4		CAPACITOR, FIXED, ELECTROLYTIC: 0.33 uF; MIL Type CS13BF334K.	5-14
1A6A1C5		CAPACITOR, FIXED, ELECTROLYTIC: 6.8 uF; MIL Type CS13BF685K.	5-14
1A6A1C6		CAPACITOR, FIXED, ELECTROLYTIC: 1.0 uF; MIL Type CS13BF105K.	5-14
1A6A1C7		CAPACITOR, FIXED, ELECTROLYTIC: 0.33 uF; MIL Type CS13BF334K.	5-14
1A6A1C8 and 1A6A1C9 1A6A1C10		CAPACITOR, FIXED, PAPER: 0.022 uF; MIL Type CP05A1KC223K3.	5-14
1A6A1C11		CAPACITOR, FIXED, ELECTROLYTIC: 3.3 uF; MIL Type CS13BF335K.	5-14
1A6A1C12		CAPACITOR, FIXED, ELECTROLYTIC: 4.7 uF; MIL Type CS13BC475M.	5-14
1A6A1C13		CAPACITOR, FIXED, ELECTROLYTIC: 22 uF; MIL Type CS13BF226K.	5-14
1A6A1C14		CAPACITOR, FIXED, ELECTROLYTIC: 3.3 uF; MIL Type CS13BF335K.	5-14
1A6A1C15		CAPACITOR, FIXED, ELECTROLYTIC: 3.3 uF; MIL Type CS13BF335K.	5-14
1A6A1C16		CAPACITOR, FIXED, ELECTROLYTIC: 15 uF; MIL Type CS13BE156K.	5-14
1A6A1C17		CAPACITOR, FIXED, MICA: 470 uF; MIL Type CM06FD471J03.	5-14
		CAPACITOR, FIXED, ELECTROLYTIC: 6.8 uF; MIL Type CS13BF685K.	5-14
		CAPACITOR, FIXED, ELECTROLYTIC: 15 uF; MIL Type CS13BE156K.	5-14

Table 7-7. Maintenance Parts List for Module 1A6 (Continued)

REF DESIG	NOTES	NAME AND DESCRIPTION	FIGURE NUMBER
1A6A1C18		CAPACITOR, FIXED, ELECTROLYTIC: 3.3 uF; MIL Type CS13BF335K.	5-14
1A6A1C19		CAPACITOR, FIXED, MICA: 2000 uF, MIL Type CM06FD202J03.	5-14
1A6A1C20		CAPACITOR, FIXED, ELECTROLYTIC: 6.8 uF; MIL Type CS13BF685K.	5-14
1A6A1CR1 thru 1A6A1CR16 1A6A1FL1		SEMICONDUCTOR, DIODE: MIL Type 1N4148.	5-14
1A6A1Q1 thru 1A6A1Q5 1A6A1Q6 1A6A1Q7 thru 1A6A1Q18 1A6A1Q19 1A6A1Q20 and 1A6A1Q21		FILTER, POST DETECTION: Mfr 96238, dwg 43020158-000.	5-14
1A6A1R1 1A6A1R2		TRANSISTOR, NPN: MIL Type 1N1613.	5-14
1A6A1R3		TRANSISTOR, PNP: MIL Type 2N2905.	5-14
1A6A1R4		TRANSISTOR, NPN: MIL Type 1N1613.	5-14
1A6A1R5		TRANSISTOR, PNP: MIL Type 2N2905.	5-14
1A6A1R6		TRANSISTOR, NPN: MIL Type 1N1613.	5-14
1A6A1R7 and 1A6A1R8 1A6A1R9		NOT USED.	
1A6A1R10		RESISTOR, FIXED, COMPOSITION: 100k ohms, 1/2 W, 5%; MIL Type RC20GF104J.	5-14
		RESISTOR, FIXED, COMPOSITION: 150 ohms, 1/2 W, 5%; MIL Type RC20GF151J.	5-14
		RESISTOR, FIXED, COMPOSITION: 68k ohms, 1/2 W, 5%; MIL Type RC20GF683J.	5-14
		RESISTOR, FIXED, COMPOSITION: 2.7k ohms, 1/2 W, 5%; MIL Type RC20GF272J.	5-14
		RESISTOR, FIXED, COMPOSITION: 680 ohms, 1/2 W, 5%; MIL Type RC20GF681J.	5-14
		RESISTOR, FIXED, COMPOSITION: 10k ohms, 1/2 W, 5%; MIL Type RC20GF103J	5-14
		RESISTOR, FIXED, COMPOSITION: 150 ohms, 1/2 W, 5%; MIL Type RC20GF151J.	5-14
		RESISTOR, FIXED, COMPOSITION: 180 ohms, 1/2 W, 5%; MIL Type RC20GF181J.	5-14

Table 7-7. Maintenance Parts List for Module 1A6 (Continued)

REF DESIG	NOTES	NAME AND DESCRIPTION	FIGURE NUMBER
1A6A1R11		RESISTOR, FIXED, COMPOSITION: 100k ohms, 1/2 W, 5%; MIL Type RC20GF104J.	5-14
1A6A1R12		RESISTOR, FIXED, COMPOSITION: 150 ohms, 1/2 W, 5%; MIL Type RC20GF151J.	5-14
1A6A1R13		RESISTOR, FIXED, COMPOSITION: 2.7k ohms, 1/2 W, 5%; MIL Type RC20GF272J.	5-14
1A6A1R14		RESISTOR, FIXED, COMPOSITION: 2.2k ohms, 1/2 W, 5%; MIL Type RC20GF222J.	5-14
1A6A1R15		RESISTOR, FIXED, COMPOSITION: 10k ohms, 1/2 W, 5%; MIL Type RC20GF103J.	5-14
1A6A1R16		RESISTOR, FIXED, COMPOSITION: 6.8k ohms, 1/2 W, 5%; MIL Type RC20GF682J.	5-14
1A6A1R17		RESISTOR, FIXED, COMPOSITION: 18k ohms, 1/2 W, 5%; MIL Type RC20GF183J.	5-14
1A6A1R18		RESISTOR, FIXED, COMPOSITION: 12k ohms, 1/2 W, 5%; MIL Type RC20GF123J.	5-14
1A6A1R19		RESISTOR, FIXED, COMPOSITION: 10k ohms, 1/2 W, 5%; MIL Type RC20GF103J.	5-14
1A6A1R20		RESISTOR, FIXED, COMPOSITION: 220 ohms, 1/2 W, 5%; MIL Type RC20GF221J.	5-14
1A6A1R21		RESISTOR, FIXED, COMPOSITION: 3.9k ohms, 1/2 W, 5%; MIL Type RC20GF392J.	5-14
1A6A1R22		RESISTOR, FIXED, COMPOSITION: 6.8k ohms, 1/2 W, 5%; MIL Type RC20GF682J.	5-14
1A6A1R23		RESISTOR, FIXED, COMPOSITION: 10k ohms, 1/2 W, 5%; MIL Type RC20GF103J.	5-14
1A6A1R24 and 1A6A1R25		RESISTOR, FIXED, COMPOSITION: 1.8k ohms, 1/2 W, 5%; MIL Type RC20GF182J.	5-14
1A6A1R26		RESISTOR, FIXED, COMPOSITION: 15k ohms, 1/2 W, 5%; MIL Type RC20GF153J.	5-14
1A6A1R27		RESISTOR, FIXED, COMPOSITION: 12k ohms, 1/2 W, 5%; MIL Type RC20GF123J.	5-14
1A6A1R28		RESISTOR, FIXED, COMPOSITION: 11k ohms, 1/2 W, 5%; MIL Type RC20GF113J.	5-14
1A6A1R29		RESISTOR, FIXED, COMPOSITION: 2.2k ohms, 1/2 W, 5%; MIL Type RC20GF222J.	5-14
1A6A1R30		RESISTOR, FIXED, COMPOSITION: 5.1k ohms, 1/2 W, 5%; MIL Type RC20GF512J.	5-14
1A6A1R31		RESISTOR, FIXED, COMPOSITION: 62k ohms, 1/2 W, 5%; MIL Type RC20GF623.	5-14

Table 7-7. Maintenance Parts List for Module 1A6 (Continued)

REF DESIG	NOTES	NAME AND DESCRIPTION	FIGURE NUMBER
1A6A1R32		RESISTOR, FIXED, COMPOSITION: 7.5k ohms, 1/2 W, 5%; MIL Type RC20GF752J.	5-14
1A6A1R33		NOT USED.	
1A6A1R34		RESISTOR, FIXED, COMPOSITION: 5.1k ohms, 1/2 W, 5%; MIL Type RC20GF512J.	5-14
1A6A1R35		RESISTOR, FIXED, COMPOSITION: 330k ohms, 1/2 W, 5%; MIL Type RC20GF334J.	5-14
1A6A1R36		RESISTOR, FIXED, COMPOSITION: 240k ohms, 1/2 W, 5%; MIL Type RC20GF244J.	5-14
1A6A1R37		RESISTOR, FIXED, COMPOSITION: 1k ohms, 1/2 W, 5%; MIL Type RC20GF102J.	5-14
1A6A1R38		RESISTOR, FIXED, COMPOSITION: 9.1k ohms, 1/2 W, 5%; MIL Type RC20GF912J.	5-14
1A6A1R39		RESISTOR, FIXED, COMPOSITION: 10k ohms, 1/2 W, 5%; MIL Type RC20GF103J.	5-14
1A6A1R40		RESISTOR, FIXED, COMPOSITION: 1.5k ohms, 1/2 W, 5%; MIL Type RC20GF152J.	5-14
1A6A1R41		RESISTOR, FIXED, COMPOSITION: 4.3k ohms, 1/2 W, 5%; MIL Type RC20GF432J.	5-14
1A6A1R42		RESISTOR, FIXED, COMPOSITION: 10k ohms, 1/2 W, 5%; MIL Type RC20GF103J.	5-14
1A6A1R43		RESISTOR, FIXED, COMPOSITION: 470 ohms, 1/2 W, 5%; MIL Type RC20GF471J.	5-14
1A6A1R44		RESISTOR, FIXED, COMPOSITION: 6.2k ohms, 1/2 W, 5%; MIL Type RC20GF622J.	5-14
1A6A1R45		RESISTOR, FIXED, COMPOSITION: 47k ohms, 1/2 W, 5%; MIL Type RC20GF473J.	5-14
1A6A1R46		RESISTOR, FIXED, COMPOSITION: 1.5k ohms, 1/2 W, 5%; MIL Type RC20GF152J.	5-14
1A6A1R47		RESISTOR, FIXED, COMPOSITION: 5.1k ohms, 1/2 W, 5%; MIL Type RC20GF512J.	5-14
1A6A1R48		RESISTOR, FIXED, COMPOSITION: 24k ohms, 1/2 W, 5%; MIL Type RC20GF243J.	5-14
1A6A1R49		RESISTOR, FIXED, COMPOSITION: 10k ohms, 1/2 W, 5%; MIL Type RC20GF103J.	5-14
1A6A1R50		RESISTOR, FIXED, COMPOSITION: 5.1k ohms, 1/2 W, 5%; MIL Type RC20GF512J.	5-14
1A6A1R51		RESISTOR, FIXED, COMPOSITION: 150 ohms, 1/2 W, 5%; MIL Type RC20GF151J.	5-14
1A6A1R52		RESISTOR, FIXED, COMPOSITION: 1.2k ohms, 1/2 W, 5%; MIL Type RC20GF122J.	5-14

Table 7-7. Maintenance Parts List for Module 1A6 (Continued)

REF DESIG	NOTES	NAME AND DESCRIPTION	FIGURE NUMBER
1A6A1R53		RESISTOR, FIXED, COMPOSITION: 10k ohms, 1/2 W, 5%; MIL Type RC20GF103J.	5-14
1A6A1R54		RESISTOR, FIXED, COMPOSITION: 2.2k ohms, 1/4 W, 5%; MIL Type RC20GF222J.	5-14
1A6A1R55		RESISTOR, FIXED, COMPOSITION: 1.8k ohms, 1/2 W, 5%; MIL Type RC20GF182J.	5-14
1A6A1R56		RESISTOR, FIXED, COMPOSITION: 10k ohms, 1/2 W, 5%; MIL Type RC20GF103J.	5-14
1A6A1R57		RESISTOR, FIXED, COMPOSITION: 18k ohms, 1/2 W, 5%; MIL Type RC20GF183J.	5-14
1A6A1R58		RESISTOR, FIXED, COMPOSITION: 47k ohms, 1/2 W, 5%; MIL Type RC20GF473J.	5-14
1A6A1R59		RESISTOR, FIXED, COMPOSITION: 12k ohms, 1/2 W, 5%; MIL Type RC20GF123J.	5-14
1A6A1R60		RESISTOR, FIXED, COMPOSITION: 22k ohms, 1/2 W, 5%; MIL Type RC20GF223J.	5-14
1A6A1R61		RESISTOR, FIXED, COMPOSITION: 18k ohms, 1/2 W, 5%; MIL Type RC20GF183J.	5-14
1A6A1R62		RESISTOR, FIXED, COMPOSITION: 22k ohms, 1/2 W, 5%; MIL Type RC20GF223J.	5-14
1A6A1R63		RESISTOR, FIXED, COMPOSITION: 5.6k ohms, 1/2 W, 5%; MIL Type RC20GF562J.	5-14
1A6A1R64		RESISTOR, FIXED, COMPOSITION: 18k ohms, 1/2 W, 5%; MIL Type RC20GF183J.	5-14
1A6A1R65		RESISTOR, FIXED, COMPOSITION: 22k ohms, 1/2 W, 5%; MIL Type RC20GF223J.	5-14
1A6A1R66		RESISTOR, FIXED, COMPOSITION: 150 ohms, 1/2 W, 5%; MIL Type RC20GF151J.	5-14
1A6A1R67		RESISTOR, FIXED, COMPOSITION: 18k ohms, 1/2 W, 5%; MIL Type RC20GF183J.	5-14
1A6A1T1		TRANSFORMER: Mfr. 96238, dwg 43001138-000.	5-14
1A6A1VR1		SEMICONDUCTOR, DIODE, ZENER: MIL Type 1N751A.	5-14
1A6A2		FRONT PANEL ASSEMBLY, RECEIVE: Consists of panel and components which mounts and supplies part of the circuitry of the RECEIVE MODULE ASSEMBLY, mfr 96238, dwg 90205007-000.	5-14

Table 7-7. Maintenance Parts List for Module 1A6 (Continued)

REF DESIG	NOTES	NAME AND DESCRIPTION	FIGURE NUMBER
1A6A2R1		RESISTOR, VARIABLE: 10k ohms, 1/2 W, 5%; MIL Type RV6LAYS103C. NOT USED.	5-14
1A6A2R2 thru 1A6A2R32		RESISTOR, VARIABLE: 5k ohms, 1/2 W, 5%; MIL Type RV6LAYS502A.	5-14
1A6A2R33  1A6W1		CABLE ASSEMBLY: Mfg 96238, dwg 75010080-000.	5-14



Table 7-8. Maintenance Parts List for Module 1A7

REF DESIG	NOTES	NAME AND DESCRIPTION	FIGURE NUMBER
1A7		COMPONENT BOARD ASSEMBLY, OUTPUT KEYING: Printed component board with all components assembled, ready for operation; mfg 96238, dwg 80205060-000.	5-16
1A7C1		CAPACITOR, FIXED, PAPER: 0.039 $\mu$ F; MIL Type CPO5A1KC393K3.	5-16
1A7C2		CAPACITOR, FIXED, ELECTROLYTIC: 10 $\mu$ F; MIL Type CS13BF106k.	5-16
1A7C3		CAPACITOR, FIXED, MICA: 0.003 $\mu$ F; MIL Type CM06FD302J03.	5-16
1A7C4		CAPACITOR, FIXED, MICA: 0.001 $\mu$ F; MIL Type CM06FD102J03.	5-16
1A7C5 and 1A7C6 1A7C7		CAPACITOR, FIXED, PAPER: 0.047 $\mu$ F; MIL Type CPO5A1KC473K3.	5-16
1A7C8		CAPACITOR, FIXED, MICA: 0.003 $\mu$ F; MIL Type CM06FD302J03.	5-16
1A7C9		CAPACITOR, FIXED, MICA: 0.001 $\mu$ F; MIL Type CM06FD102J03.	5-16
1A7C10		CAPACITOR, FIXED, ELECTROLYTIC: 1.0 $\mu$ F; MIL Type CS13BF105k.	5-16
1A7C11		CAPACITOR, FIXED, PAPER, 0.047 $\mu$ F; MIL Type CPO5A1KC473K3.	5-16
1A7C12 thru 1A7C21		CAPACITOR, FIXED, PAPER, 0.047 $\mu$ F; MIL Type CPO5A1KC473K3.	5-16
1A7CR1		SEMICONDUCTOR, DIODE, MIL Type 1N645.	5-16
1A7CR2		SEMICONDUCTOR, DIODE, MIL Type 1N4148.	5-16
1A7CR3		SEMICONDUCTOR, DIODE, MIL Type 1N645.	5-16
1A7CR4		SEMICONDUCTOR, DIODE, MIL Type 1N4148.	5-16
1A7CR5 thru 1A7CR7		SEMICONDUCTOR, DIODE, MIL Type 1N645.	5-16
1A7L1 and 1A7L2		INDUCTOR, MIL Type MS 90537-53.	5-16

Table 7-8. Maintenance Parts List for Module 1A7 (Continued)

REF DESIG	NOTES	NAME AND DESCRIPTION	FIGURE NUMBER
1A7Q1 thru 1A7Q3 1A7Q4		TRANSISTOR, NPN: MIL Type 2N1613.	5-16
1A7Q5		TRANSISTOR, NPN, SWITCH: ST201A Mfg 96238, dwg 40001201-001.	5-16
1A7Q6		TRANSISTOR, PNP; MIL Type 2N2905.	5-16
1A7Q7		TRANSISTOR, NPN: MIL Type 2N1613.	5-16
1A7Q8		TRANSISTOR, NPN, SWITCH: ST201A Mfg 96238, dwg 40001201-001.	5-16
1A7Q9		TRANSISTOR, NPN: MIL Type 2N1613.	5-16
thru 1A7Q10		TRANSISTOR, PNP; MIL Type 2N2905.	5-16
1A7Q11		TRANSISTOR, NPN: MIL Type 2N1613.	5-16
1A7R1		RESISTOR, FIXED, COMPOSITION: 56k ohms, 1/2 W, 5%; MIL Type RC20GF563J.	5-16
1A7R2		RESISTOR, FIXED, COMPOSITION: 7.5k ohms, 1/2 W, 5%; MIL Type RC20GF752J.	5-16
1A7R3		RESISTOR, FIXED, COMPOSITION: 4.7k ohms, 1/2 W, 5%; MIL Type RC20GF472J.	5-16
1A7R4		RESISTOR, FIXED, COMPOSITION: 100 ohms, 1/2 W, 5%; MIL Type RC20GF101J.	5-16
1A7R5		RESISTOR, FIXED, COMPOSITION: 18k ohms, 1/2 W, 5%; MIL Type RC20GF183J.	5-16
1A7R6		RESISTOR, FIXED, COMPOSITION: 27k ohms, 1/2 W, 5%; MIL Type RC20GF273J.	5-16
1A7R7		RESISTOR, FIXED, COMPOSITION: 15k ohms, 1/2 W, 5%; MIL Type RC20GF153J.	5-16
1A7R8		RESISTOR, FIXED, COMPOSITION: 22 ohms, 1/2 W, 5%; MIL Type RC20GF220J.	5-16
1A7R9 and 1A7R10		RESISTOR, FIXED, COMPOSITION: 270 ohms, 1/2 W, 5%; MIL Type RC20GF271J.	5-16
1A7R11		RESISTOR, FIXED, COMPOSITION: 2.7k ohms, 1/2 W, 5%; MIL Type RC20GF272J.	5-16
1A7R12		RESISTOR, FIXED, COMPOSITION: 20k ohms, 1/2 W, 5%; MIL Type RC20GF203J.	5-16
1A7R13		RESISTOR, FIXED, COMPOSITION: 510 ohms, 1/2 W, 5%; MIL Type RC20GF511J.	5-16
1A7R14		RESISTOR, FIXED, COMPOSITION: 15k ohms, 1/2 W, 5%; MIL Type RC20GF153J.	5-16

Table 7-8. Maintenance Parts List for Module 1A7 (Continued)

REF DESIG	NOTES	NAME AND DESCRIPTION	FIGURE NUMBER
1A7R15		RESISTOR, FIXED, COMPOSITION: 22 ohms, 1/2 W, 5%; MIL Type RC20GF220J.	5-16
1A7R16 and 1A7R17 1A7R18		RESISTOR, FIXED, COMPOSITION: 270 ohms, 1/2 W, 5%; MIL Type RC20GF271J.	5-16
1A7R19 thru 1A7R21 1A7R22		RESISTOR, FIXED, COMPOSITION: 2.7k ohms, 1/2 W, 5%; MIL Type RC20GF272J.	5-16
1A7R23		RESISTOR, FIXED, COMPOSITION: 22 ohms, 1/2 W, 5%; MIL Type RC20GF220J.	5-16
1A7R24		RESISTOR, FIXED, COMPOSITION: 1k ohms, 1/2 W, 5%; MIL Type RC20GF102J.	5-16
1A7R25		RESISTOR, FIXED, FILM: 10 ohms, 1/2 W, 1%; MIL Type RN60D10R0F.	5-16
1A7R26 and 1A7R27 1A7R28 and 1A7R29 1A7R30 and 1A7R31 1A7R32		RESISTOR, FIXED, FILM: 4.3k ohms, 1/2 W, 1%; MIL Type RN65D4321F.	5-16
1A7R33		RESISTOR, FIXED, COMPOSITION: 22 ohms, 1/2 W, 5%; MIL Type RC20GF220J.	5-16
1A7R34 and 1A7R35 1A7R36		RESISTOR, FIXED, COMPOSITION: 1k ohms, 1/2 W, 5%; MIL Type RC20GF102J.	5-16
1A7T1 and 1A7T2		RESISTOR, FIXED, COMPOSITION: 2.7k ohms, 1/2 W, 5%; MIL Type RC20GF272J.	5-16
		RESISTOR, FIXED, COMPOSITION: 5.1k ohms, 1/2 W, 5%; MIL Type RC20GF512J.	5-16
		RESISTOR, FIXED, COMPOSITION: 27k ohms, 1/2 W, 5%; MIL Type RC20GF273J.	5-16
		RESISTOR, FIXED, COMPOSITION: 4.7k ohms, 1/2 W, 5%; MIL Type RC20GF472J.	5-16
		RESISTOR, FIXED, COMPOSITION: 2.7k ohms, 1/2 W, 5%; MIL Type RC20GF272J.	5-16
		RESISTOR, FIXED, COMPOSITION: 4.7k ohms, 1/2 W, 5%; MIL Type RC20GF472J.	5-16
		TRANSFORMER, PULSE: Mfr 96238, dwg 43003040-000.	5-16

Table 7-9. Maintenance Parts List for Module 1A8

REF DESIG	NOTES	NAME AND DESCRIPTION	FIGURE NUMBER
1A8		COMPONENT BOARD ASSEMBLY, RECEIVE FILTER LO-BAND: Printed component board with all components assembled, ready for operation; mfr 96238, dwg 80205080-001.	5-18
1A8C1		CAPACITOR, FIXED, ELECTROLYTIC: 0.33 $\mu$ F; MIL Type CS13BF334k.	5-18
1A8C2		CAPACITOR, FIXED, CERAMIC: 0.01 $\mu$ F; MIL Type CK63AW103K.	5-18
1A8C3		CAPACITOR, FIXED, ELECTROLYTIC: 10 $\mu$ F; MIL Type CK63AW106K.	5-18
1A8C4 thru 1A8C6 1A8C7		CAPACITOR, FIXED, ELECTROLYTIC: 1.0 $\mu$ F; MIL Type CS13BF105k.	5-18
1A8CR1 and 1A8CR2 1A8Q1 thru 1A8Q3 1A8R1		CAPACITOR, FIXED, ELECTROLYTIC: 3.3 $\mu$ F; MIL Type CS13BF335k.	5-18
		SEMICONDUCTOR, DIODE: MIL Type 1N4148.	5-18
		TRANSISTOR, NPN: MIL Type 2N1613.	5-18
		RESISTOR, FIXED COMPOSITION: 10k ohms, 1/2 W, 5%; MIL Type RC20GF103J.	5-18
1A8R2		RESISTOR, FIXED COMPOSITION: 120k ohms, 1/2 W, 5%; MIL Type RC20GF124J.	5-18
1A8R3		RESISTOR, FIXED COMPOSITION: 180-270 ohms, 1/2 W, 5%; MIL Type RC20GF124J. (SELECT AT TEST).	5-18
1A8R4		RESISTOR, FIXED COMPOSITION: 3.3k ohms, 1/2 W, 5%; MIL Type RC20GF332J.	5-18
1A8R5		RESISTOR, FIXED COMPOSITION: 2k ohms, 1/2 W, 5%; MIL Type RC20GF202J.	5-18
1A8R6		RESISTOR, FIXED COMPOSITION: 150k ohms, 1/2 W, 5%; MIL Type RC20GF154J.	5-18
1A8R7		RESISTOR, FIXED COMPOSITION: 150 ohms, 1/2 W, 5%; MIL Type RC20GF151J.	5-18
1A8R8		RESISTOR, FIXED COMPOSITION: 3.3k ohms, 1/2 W, 5%; MIL Type RC20GF332J.	5-18

Table 7-9. Maintenance Parts List for Module 1A8 (Continued)

REF DESIG	NOTES	NAME AND DESCRIPTION	FIGURE NUMBER
1A8R9		RESISTOR, FIXED COMPOSITION: 33k ohms, 1/2 W, 5%; MIL Type RC20GF333J.	5-18
1A8R10		RESISTOR, FIXED FILM: 1k ohms, 1/4 W, 1%; MIL Type RN65C1001F.	5-18
1A8R11		RESISTOR, FIXED FILM: 1050 ohms, 1/4 W, 1%; MIL Type RN65C1051F.	5-18
1A8Z1		FILTER, BAND PASS: Mfr 96238, dwg 43020142-000.	5-18
1A8Z2		FILTER, BAND PASS: Mfr 96238 dwg 43006014-000.	5-18

Table 7-10. Maintenance Parts List for Module 1A9

REF DESIG	NOTES	NAME AND DESCRIPTION	FIGURE NUMBER
1A9		COMPONENT BOARD ASSEMBLY, RECEIVE FILTER HI-BAND: Printed component board with all components assembled, ready for operation; mfr 96238, dwg 80205080-002.	5-18
1A9C1		CAPACITOR, FIXED, ELECTROLYTIC: 0.33 $\mu$ F; MIL Type CS13BF334k.	5-18
1A9C2		CAPACITOR, FIXED, CERAMIC: 0.01 $\mu$ F; MIL Type CK63AW103K.	5-18
1A9C3		CAPACITOR, FIXED, ELECTROLYTIC: 10 $\mu$ F;	5-18
1A9C4		CAPACITOR, FIXED, ELECTROLYTIC: 1.0 $\mu$ F;	5-18
thru 1A9C6 1A9C7		MIL Type CS13BF105k.	
		CAPACITOR, FIXED, ELECTROLYTIC: 3.3 $\mu$ F; MIL Type CS13BF335k.	5-18
1A9CR1 and 1A9CR2		SEMICONDUCTOR, DIODE: MIL Type 1N4148.	5-18
1A9Q1 thru 1A9Q3 1A9R1		TRANSISTOR, NPN: MIL Type 2N1613.	5-18
		RESISTOR, FIXED COMPOSITION: 10k ohms, 1/2 W, 5%; MIL Type RC20GF103J.	5-18
1A9R2		RESISTOR, FIXED COMPOSITION: 120k ohms, 1/2 W, 5%; MIL Type RC20GF124J.	5-18
1A9R3		RESISTOR, FIXED COMPOSITION: 200-390 ohms, 1/2 W, 5%; MIL Type RC20GF ..... (SELECT AT TEST).	5-18
1A9R4		RESISTOR, FIXED COMPOSITION: 3.3k ohms, 1/2 W, 5%; MIL Type RC20GF332J.	5-18
1A9R5		RESISTOR, FIXED COMPOSITION: 2k ohms, 1/2 W, 5%; MIL Type RC20GF202J.	5-18
1A9R6		RESISTOR, FIXED COMPOSITION: 150k ohms, 1/2 W, 5%; MIL Type RC20GF154J.	5-18
1A9R7		RESISTOR, FIXED COMPOSITION: 150 ohms, 1/2 W, 5%; MIL Type RC20GF151J.	5-18
1A9R8		RESISTOR, FIXED COMPOSITION: 3.3k ohms, 1/2 W, 5%; MIL Type RC20GF332J.	5-18
1A9R9		RESISTOR, FIXED COMPOSITION: 33k ohms, 1/2 W, 5%; MIL Type RC20GF333J.	5-18

Table 7-10. Maintenance Parts List for Module 1A9 (Continued)

REF DESIG	NOTES	NAME AND DESCRIPTION	FIGURE NUMBER
1A9R10		RESISTOR, FIXED FILM: 1k ohms, 1/4 W, 1%; MIL Type RN65C1001F.	5-18
1A9R11		RESISTOR, FIXED FILM: 1050 ohms, 1/4 W, 1%; MIL Type RN65C1051F.	5-18
1A9Z1		FILTER, BAND, PASS: Mfr 96238, dwg 43020143-000.	5-18
1A9Z2		FILTER, BAND, PASS: Mfr 96238, dwg 43006015-000.	5-18

Table 7-11. Maintenance Parts List for Module 1A10

REF DESIG	NOTES	NAME AND DESCRIPTION	FIGURE NUMBER
1A10	1	COMPONENT BOARD ASSEMBLY, TEST PC (Extender board): Printed component board with all com- ponents assembled, ready for operation; mfr 96238, dwg 80205070-000.	
1A10J1	1	CONNECTOR, RECEPTACLE, ELECTRIC: 10 pin, female, mfr 02660, dwg 225-21021-205.	

1. Not illustrated.



Table 7-12. Maintenance Parts List for Chassis 1A11

REF DESIG	NOTES	NAME AND DESCRIPTION	FIGURE NUMBER
1A11		CHASSIS ASSEMBLY: Consists of a front panel, chassis, electronic components assembly and components which mounts and supplies part of the circuitry for the CV-2460/SGC CONVERTER; mfr 96238, dwg 90205001-000.	5-3
1A11C1 and 1A11C2		CAPACITOR, FIXED, CERAMIC: 0.1 uF, MIL Type CZ24BEB104.	5-3
1A11R1		RESISTOR, FIXED, WW: 800 ohms, MIL Type RW20V801.	5-3
1A11R2 and 1A11R3		LOCATED ON 1A11A1.	
1A11R4 and 1A11R5		LOCATED ON 1A11A2.	
1A11R6		RESISTOR, FIXED, WW: 2.5k ohms, 21 W; MIL Type RW20V252.	5-3
1A11R7 thru 1A11R14		LOCATED ON 1A11A2.	
1A11TB1 and 1A11TB2		TERMINAL BOARD: MIL Type 40TB12.	5-3
1A11XA1		CONNECTOR, RECEPTACLE, ELECTRIC: MIL Type M21097/1-037.	5-3
1A11XA2		CONNECTOR, RECEPTACLE, ELECTRIC: MIL Type M21097/1-055.	5-3
1A11XA3 and 1A11XA4		CONNECTOR, RECEPTACLE, ELECTRIC: MIL Type M21097/1-037.	5-3
1A11XA5 thru 1A11XA6		CONNECTOR, RECEPTACLE, ELECTRIC: MIL Type M21097/1-055.1A11XA6	5-3
1A11XA8 and 1A11XA9		CONNECTOR, RECEPTACLE, ELECTRIC: MIL Type M21097/1-037.	5-3

Table 7-12. Maintenance Parts List for Chassis 1A11 (Continued)

REF DESIG	NOTES	NAME AND DESCRIPTION	FIGURE NUMBER
1A11A1		FRONT PANEL ASSEMBLY: Consists of a panel and components and makes up part of the chassis assembly; mfr 96238, dwg 90205003-000.	5-2
1A11A1DS1		LAMP, INCANDESCENT: MIL Type MS25237-327.	5-2
1A11A1DS2 and 1A11A1DS3 1A11A1DS4 and 1A11A1DS5		LAMP, INCANDESCENT: MIL Type MS1557/-2.	5-2
1A11A1F1 and 1A11A1F2		LAMP, INCANDESCENT: MIL Type MS25237-327.	5-2
1A11A1J1		FUSE, CARTRIDGE: 0.25A SLO-BLO; MIL Type F02B250V1/4AS.	5-2
1A12A1K1		JACK, TELEPHONE: MIL Type JJ034.	5-2
1A11A1M1		RELAY: Mfr 71482 RP7633G4.	5-2
1A11A1R1 1A11A1R2 and 1A11A1R3 1A11A1S1		METER, DECIBEL: Mfr 96238, dwg 48081084-000. LOCATED ON 1A11. RHEOSTAT: 3.5k ohms; Mfr 96238; dwg 41900028-000.	5-2
1A11A1S2		SWITCH, ROTARY: 8 pole, 2 POSITION; Mfr 96238, dwg 46020569-000.	5-2
1A11A1S3		SWITCH, ROTARY; 4 pole, 2 POSITION; Mfr 96238, dwg 46020406-000.	5-2
1A11A1S4		SWITCH, ROTARY: 10 pole, 5 POSITION; Mfr 96238, dwg 46020377-000.	5-2
1A11A1S5		SWITCH, ROTARY: 3 pole, 8 POSITION; Mfr 96238, dwg 46020372-000.	5-2
1A11A1XDS1		SWITCH, TOGGLE: MIL Type MS25100-220.	5-2
1A11A1XDS2 and 1A11A1XDS3 1A11A1XDS4 1A11A1XDS5		LAMPHOLDER: MIL Type LH73LC12RT2. LAMPHOLDER: MIL Type LH763LC14CN1.	5-20 5-20
		LAMPHOLDER: MIL Type LH73LC12GT.	5-20
		LAMPHOLDER: MIL Type LH73LC12BT2.	5-20

Table 7-12. Maintenance Parts List for Chassis 1A11 (Continued)

REF DESIG	NOTES	NAME AND DESCRIPTION	FIGURE NUMBER
1A11A1XF1 and 1A11A1XF2		FUSEHOLDER: MIL Type FHL17G.	5-20
1A11A2		ELECTRONIC COMPONENT ASSEMBLY: Part of the chassis assembly; Mfr 96238, dwg 90205014-000.	5-3
1A11A2R1		LOCATED ON 1A11.	
1A11A2R2		LOCATED ON 1A11A1.	
1A11A2R3		LOCATED ON 1A11A1.	
1A11A2R4 and 1A11A2R5		RESISTOR, FIXED, FILM: 3k ohms, 1%; MIL Type RN60D3011F.	5-3
1A11A2R6		LOCATED ON 1A11.	5-3
1A11A2R7		RESISTOR, FIXED, FILM: 10 ohms, 1% MIL Type RN60D10R0F.	5-3
1A11A2R8		RESISTOR, FIXED, FILM: 4.3k ohms, 1% MIL Type RN60D4321F.	5-3
1A11A2R9		RESISTOR, FIXED, COMPOSITION: 100 ohms, 5% MIL Type RC20GF101J.	5-3
1A11A2R10 and 1A11A2R11		RESISTOR, FIXED, FILM: 110k ohms, 1% MIL Type RN65C1103F.	5-3
1A11A2R12 and 1A11A2R13		RESISTOR, FIXED, COMPOSITION: 300 ohms, 5% MIL Type RC20GF301J.	5-3
1A11A2R14		RESISTOR, FIXED, COMPOSITION: 430 ohms, 5% MIL Type RC20GF431J.	5-3
1A11A2R15		RESISTOR, FIXED, COMPOSITION: 2k ohms, 5% RC07GF202J.	5-3
1A11A2TB3		TERMINAL BOARD: Mfr 96238, dwg 55033152-000.	5-3
1A11A2Z1		RECTIFIER: Mfr 88141, dwg 121.	5-3

Table 7-13. List of Manufacturers

MFR CODE	NAME	ADDRESS	ZIP
02660	Amphenol Corp.	Broadview, Illinois	60153
03508	General Electric Co. Semi-Conductor Products Dept.	Auburn, New York	13021
17745	Angstrom Precision INC	Hagerstown, Maryland	21740
49671	RCA Corp.	New York, New York	10020
71482	C.P. Clare & Co.	Chicago, Illinois	60645
71785	Cinch Mfg. Co.	Chicago, Illinois	60007
75915	Littel Fuse, Inc.	Des Plaines, Illinois	60016
81349	DoD MIL Specs	Washington, D.C.	20360
88141	Conant Laboratories	Lincoln, Nebraska	68510
96238	Data Products Inc.	Wallingford, Connecticut	06492

## CHAPTER 8

## INSTALLATION

8-1. INTRODUCTION. This chapter contains unpacking and repacking instructions, site selection, power requirements, and installation instructions required to install the Telegraph-Telephone Signal Converter CV-2460/SGC. Also included are checkout and test procedures to demonstrate that the Converter is installed properly.

8-2. UNPACKING AND REPACKING INSTRUCTIONS. Before opening the shipping container, visually inspect and note any external damage. A damaged container may indicate possible physical damage to the equipment. When unpacking, do not damage the equipment being protected by the packaging materials. Note any damage to the internal packaging materials, damaged packaging materials may indicate physical damage to the equipment. Retain the packaging materials in their shipping containers for repacking. Verify the material received against material itemized on the packing list. Repacking of the equipment is the reverse order of unpacking.

8-3. VISUAL INSPECTION. Visually inspect the equipment for evidence of any physical damage during shipment. Check the following:

- a. Rear panel connectors for bent pins.
- b. Front panel for broken components.
- c. Mounting plates and chassis slides intact and operating.

WARNING

Dangerous voltages exist in this unit which could cause loss of life or serious injury.

8-4. POWER REQUIREMENTS. The Converter receives 115-volt ac, single-phase, 47 to 63 Hz, 20-watt power through terminal board TB2, located inside the rear, left side of the chassis. (A primary power distribution diagram is provided in chapter 5, figure 5-7.)

8-5. SITE SELECTION. Select a mounting location for the Converter, in accordance with the system configurations depicted in figures 1-2 and 8-1, and observe the following:

- a. Provide a minimum of 18 inches clearance at front of unit.
- b. Allow clearance to route power, signal, and control wires through either bottom rear; left rear, or left side of enclosure.
- c. Leave room for normal air circulation around unit.

- d. Place unit away from excessive heat radiation from other equipments.
- e. Position unit so that front panel is adequately illuminated.
- f. Make provisions to connect a ground strap to the unit.

8-6. MOUNTING. The Converter may be secured to a standard 19-inch relay rack, or it may be solidly mounted to a bench. The Converter also has provisions for shock-mounting. The mounting holes are spaced to mate with existing shock mounts where the Converter is used to replace Radio Teletype Terminal Set AN/SGC-1A. Mounting dimensions are shown in figure 8-2.

8-6.1 Tools and Materials Required for Installation. The Converter is slide mounted in a control rack and interfaces with antennas, switching groups and radio receivers. Installation procedures are detailed in subsequent paragraphs. The only tools required are:

- a. Common flat tip screwdriver (for captive screws).
- b. 5/16 inch nut driver (for bias potentiometers).
- c. 3/8 inch nut driver (for hex nuts).
- d. Jaw pliers (for wing nuts).

8-6.2 Rack Mounting. Secure the unit, at front and rear, as follows:

- a. Remove the 16 screws and four L-brackets from their stored positions at the rear of enclosure. Retain the 16 screws.
- b. Using the screws, fasten the four L-brackets to the front and rear of each side of the enclosure as shown in figure 8-2.
- c. Secure unit to front and rear of relay rack in normal manner. (Rack-mounting screws are not supplied.)

8-6.3 Bench Mounting. Secure unit to bench or four shock mounts as follows:

- a. Remove four bolts, and associated washers and lockwashers, from their stored positions on rear of enclosure.
- b. Remove access cover and plug from top of enclosure, and slide front panel out and swing it up. Remove extender from slot 1A10.
- c. Use the four bolts, washers, and lockwashers to secure unit to bench or shock mounts (not supplied). Four holes are provided in bottom of enclosure through which the bolts pass to mate with shock-mount centers or bench mounting holes.

OPTION 1

NOTES:

1. EXTERNAL LOOP SUPPLY REQUIRED FOR NEUTRAL OPERATION.
2. AMBIENT TEMPERATURE NOT TO GO BEYOND 0° TO +50°C. HUMIDITY 0 TO 90%.
3. CABLES BETWEEN COMPARTMENTS MUST BE ARMORED.
4. TYPE TTHFWA-1-1/2 MAY BE SUBSTITUTED WHENEVER DESIRED FOR SINGLE PAIR.

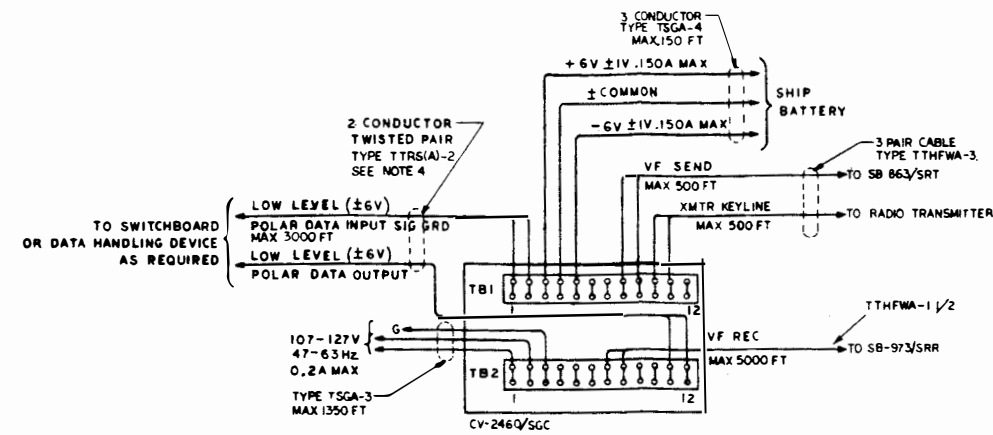

OPTION 2

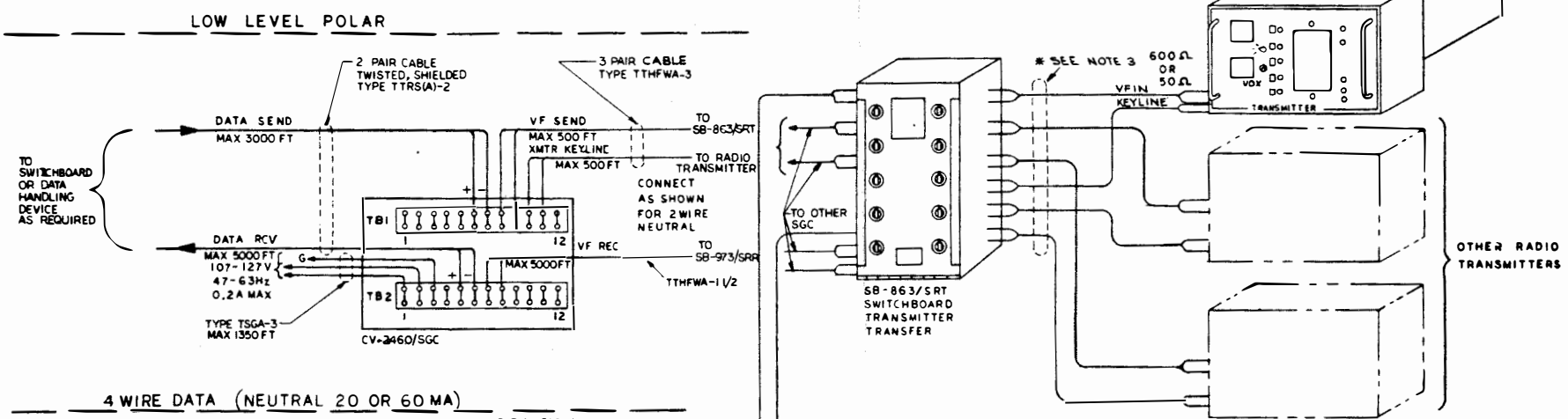

OPTION 3

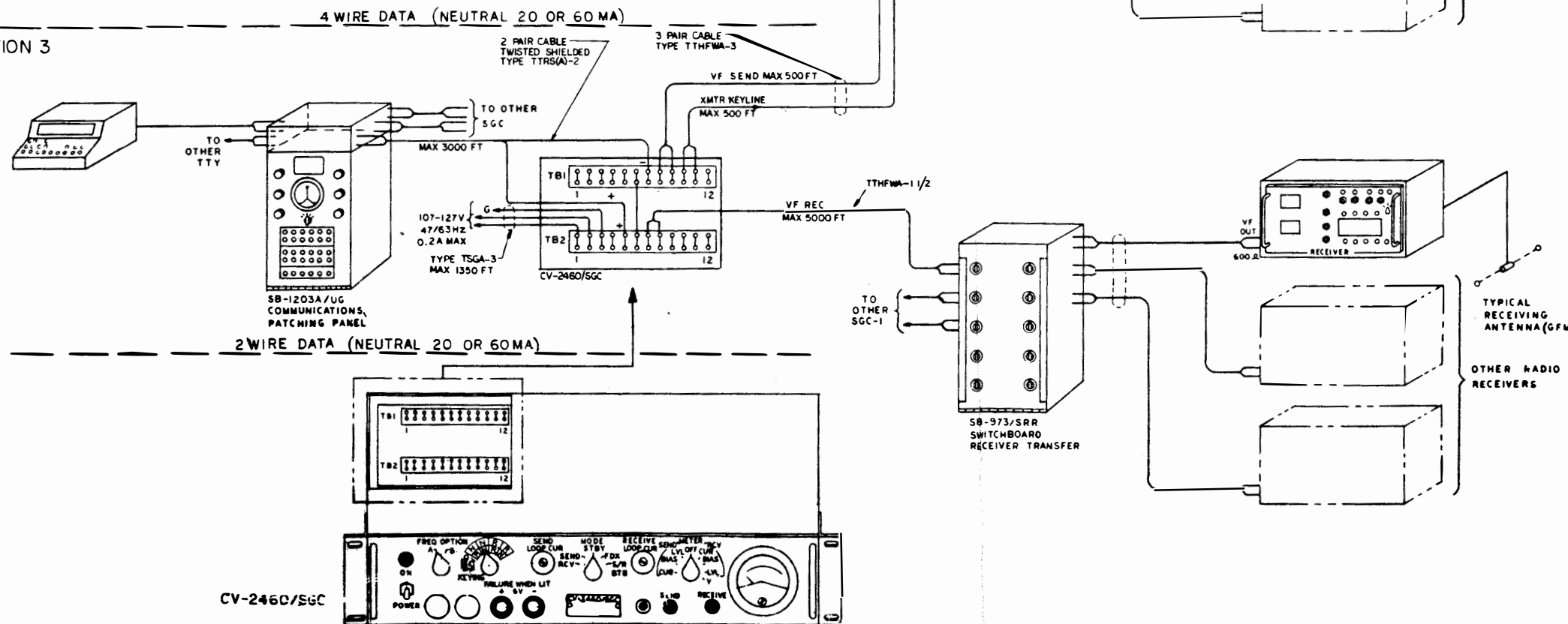

Figure 8-1. System Installation

133

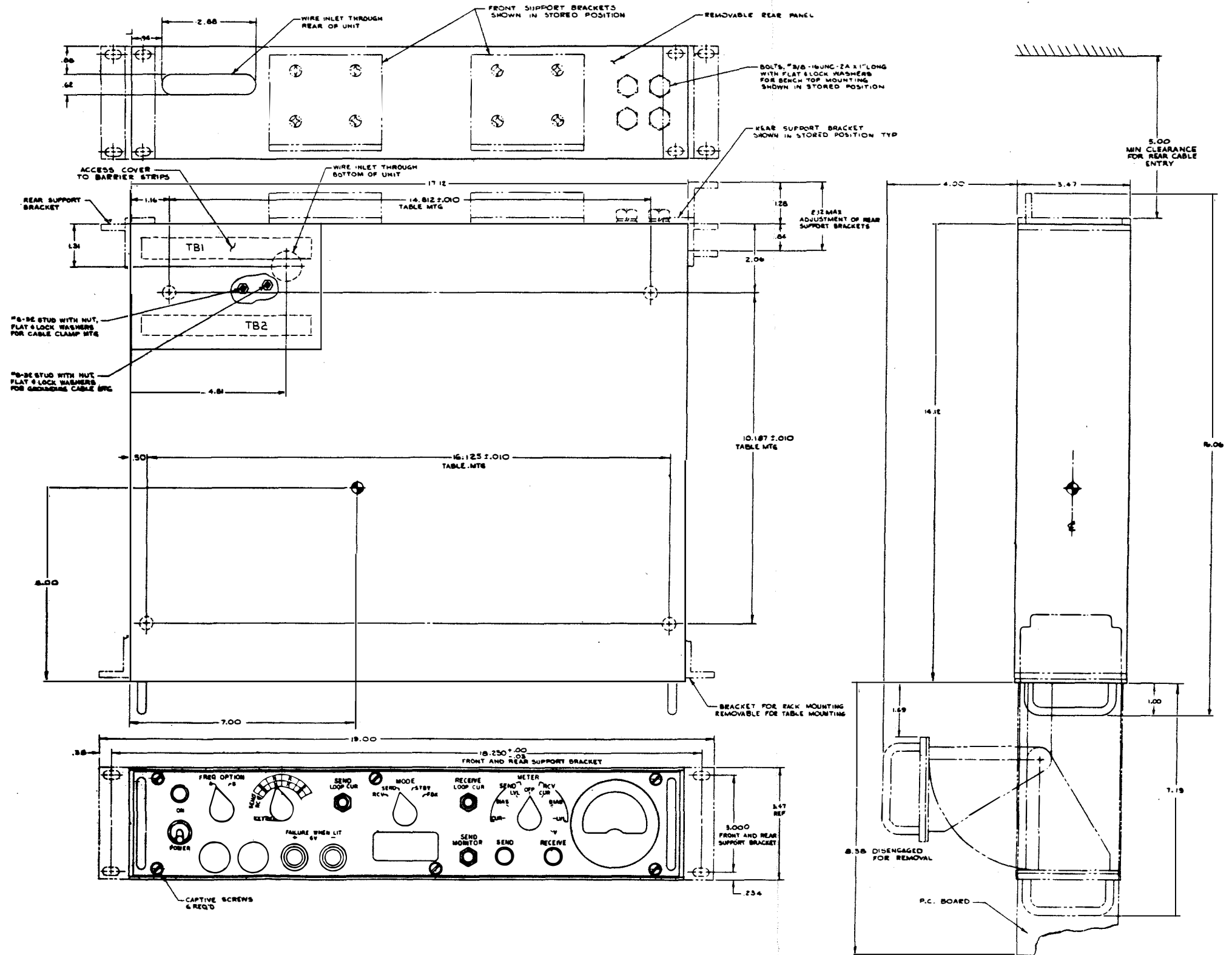

Figure 8-2. Mounting Dimensions

8-5/(8-6 BLANK)



8-7. STRAPPING. The dc-data input (send) and output (receive) circuits of the Converter are provided with the strapping options listed in table 8-1 (figure 8-3). Solder No. 22 bus-wire jumpers between the strapping terminals listed for the required mode. Remove all unrequired straps.

8-8. CONNECTIONS.

WARNING

Make sure that all external wires are not energized before making connections. Wires may connect to dangerous voltages, which could cause personal injury.

In accordance with specific Navy installation requirements (NAVELEX 0967-LP-306-1010) make the appropriate connections, of those listed in table 8-2, to terminal boards TB1 and TB2 (see figure 8-2 and pictorial system diagram, figure 8-1).

- a. Remove access cover from top, left, rear of shelf enclosure.
- b. Connect a ground strap to the enclosure.
- c. Route wires up through hole beneath terminal boards, leaving an adequate service loop.
- d. Make required connections.
- e. Replace access cover.

8-9. INITIAL POWER APPLICATION.

- a. Check that both front-panel fuses are secure in their holders and of the correct current rating as marked on the front panel.
- b. Set POWER switch to ON. POWER indicator lamp lights.
- c. Check that open-fuse indicators (on front of fuses) do not light.
- d. If external  $\pm 6$ -volt supply is included in installation, turn it on. The FAILURE WHEN LIT indicator lamps (+) and (-) should not light (if one or both lights, circuit inside Converter is shorted).
- e. Set METER switch to V position. If internal power supply output voltage is correct, front-panel meter pointer should deflect to the VOLT mark on the meter.

8-10. INITIAL CHECKS AND ADJUSTMENTS. Perform the following checks and adjustments before releasing unit to operator.

Table 8-1. Strapping Options

CARD A2 SEND STRAPPING		CARD A7 RECEIVE STRAPPING	
INPUT SIGNAL MODE	STRAP TERMINALS*	OUTPUT SIGNAL MODE	STRAP TERMINALS*
Low-level polar	9-10, 12-14	Low-level polar	2-3, 4-6, 7-8, <del>8-9</del> , 11-13, 14-16
20-mA neutral	9-11, 12-13	High level Voltage	2-3, 4-6, 7-8, <del>8-9</del> , 11-12, 14-15
60-mA neutral	9-11, 12-13 15-16, 16-17	High-level current	1-3, 4-5, <del>7-8</del> , 7-9**, 9-10

\* See figure 8-3.

\*\* Strap 7-9 used only when high level-loop current installation uses constant current regulator such as LC3.

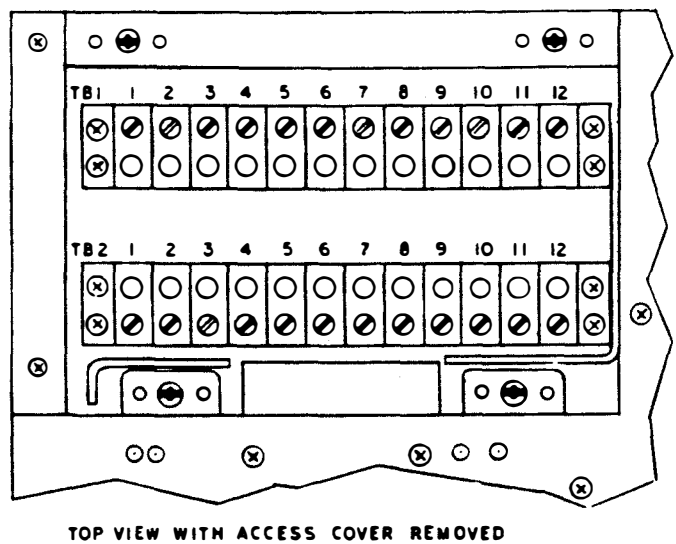
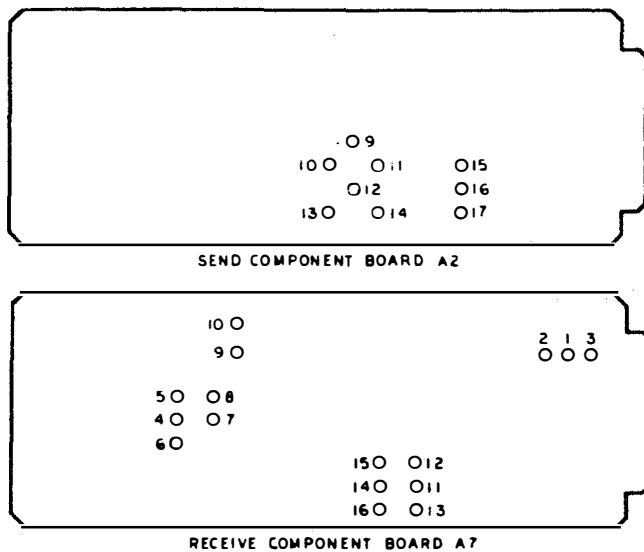

Figure 8-3. Strapping.

Figure 8-4. External Connections.

Table 8-2. Connections.

FUNCTION	CONNECTION	NOTES
115-volt ac 115-volt ac Ground	TB2-1 (line) TB2-2 (line) TB2-3 (gnd)	
Send vf out	TB1-8 TB1-9	See figure 8-1, low-level polar, 4-wire data and 2-wire data.
Receive vf in	TB2-7 TB2-8	
VOX closure	TB1-10 TB1-11	
Send low-level polar in.	TB1-1 (Sig) TB1-2 (gnd)	See figure 8-1, low-level polar. Low-level battery required.
Low-level battery in.	TB1-3 (+6V) TB1-4 (+com) TB1-5 (-6V)	
Receive low-level polar in.	TB2-12 (Sig) TB2-11 (gnd)	
Send high-level neutral in.	TB1-6 (+) TB1-7(-)	See figure 8-1, 4-wire data and 2-wire data.
Receive high- level neutral out.	TB2-5 (+) TB2-6 (-)	

WARNING

Dangerous voltages which exist inside this unit could cause loss of life or serious injury.

- a. Unscrew the six captive screws on the front panel, slide front panel out and swing it up.
- b. On component board A5, set .75 SEC/3 SEC switch to 3 SEC.
- c. On component board A2, set 600/50 switch to the position that corresponds to send-tone line impedance.
- d. On front panel:
  - (1) Set FREQ OPTION switch to A.
  - (2) Set KEYING switch to SEND N - RCV N normal signal sense or SEND R - RCV R reverse signal sense as required.
  - (3) Set MODE switch to S/R BTB.
- e. If the send channel is strapped and connected to operate in the 20 mA or 60 mA neutral mode, perform steps (1) through (5) below. If send channel is strapped to operate in the low-level mode, follow steps (1), (4), and (5).
  - (1) Apply steady marking to send channel.
  - (2) Set METER switch to SEND CUR.
  - (3) Adjust SEND LOOP CUR rheostat for correct marking current.
  - (4) Set METER switch to SEND LVL.
  - (5) Adjust OUT LVL control on board A2 for the desired output level (-10 dBm typical) as required by the radio transmitter.

NOTE

If levels below -20 dBm or above +3 dBm are required, use a VTVM connected to the SEND MONITOR jack to obtain output level.

- f. If the receive channel is strapped and connected to operate in the high-level neutral mode, perform steps (1) and (2) below. If not, go to step g.
  - (1) Set METER switch to RCV CUR.
  - (2) Adjust RECEIVE LOOP CUR rheostat for the correct marking current.

g. Set METER switch to RCV LVL, and adjust RCV LEVEL potentiometer, on board A6, for -20 dBm (assuming SEND LVL output is set for -10 dBm).

h. The Converter is factory-adjusted, but the adjustments outlined in chapter 6 may be performed at this time as an additional check.

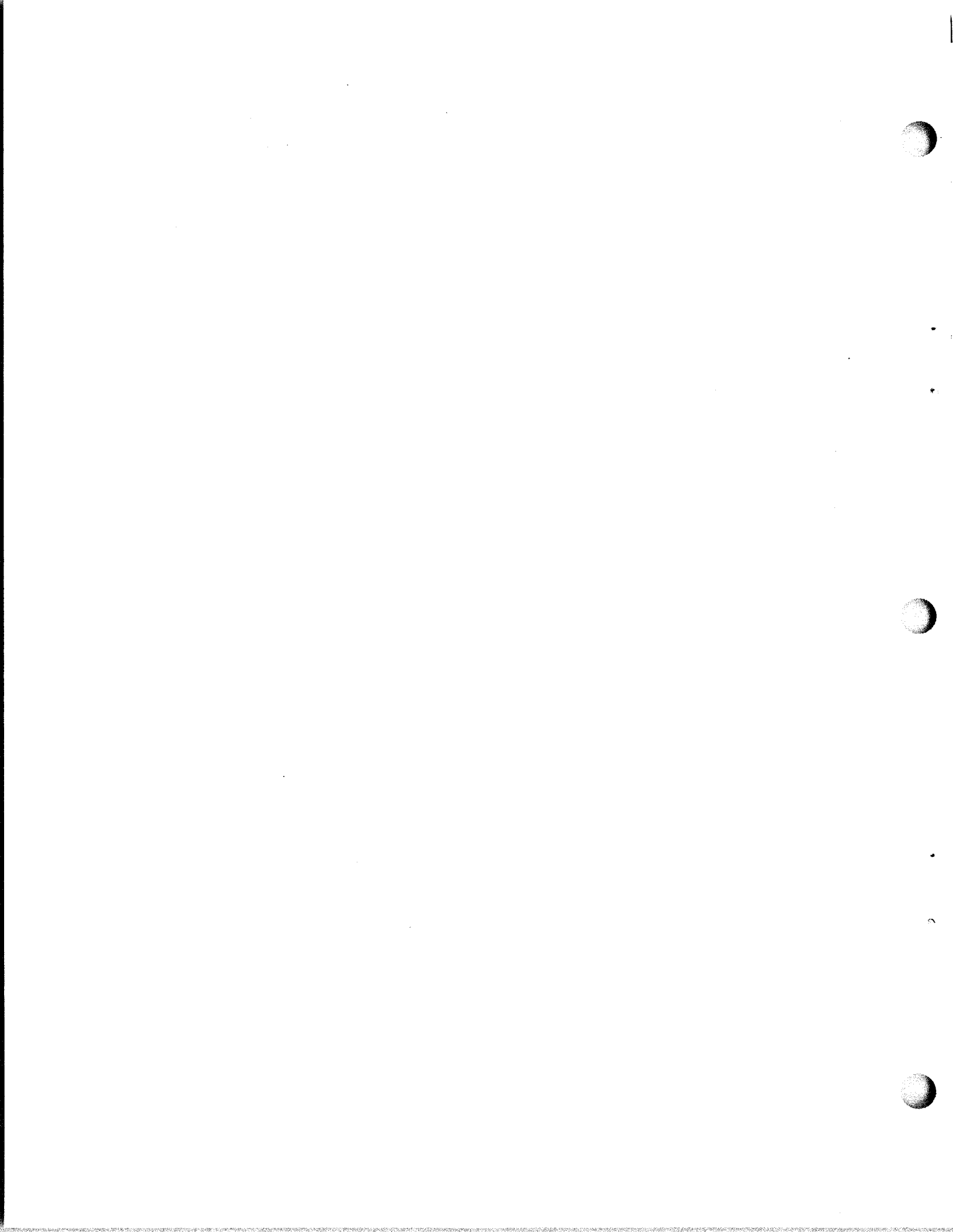

TELEGRAPH-TELEPHONE SIGNAL CONVERTER CV-2460/SGC

INSTALLATION STANDARDS SUMMARY

Input Voltage 115V ac

Date: \_\_\_\_\_

Input Frequency 47-63Hz

Serial Number: \_\_\_\_\_

Single Phase

Installed: \_\_\_\_\_

Record on this summary sheet the test indications which have been obtained during installation verification test.

*H*

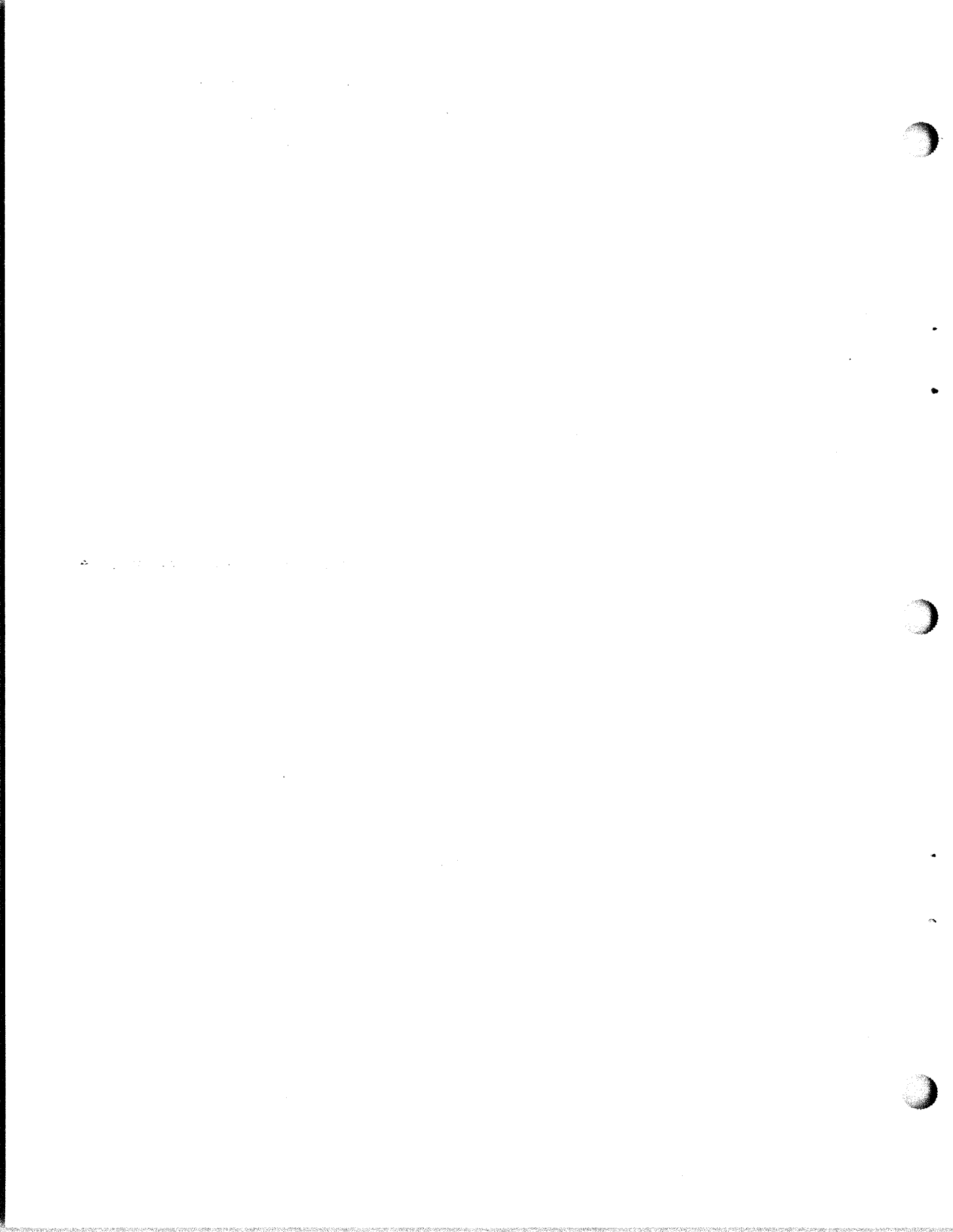



## GLOSSARY OF TERMS

BTB	Back-to-Back
CUR	Current
dBm	Decibels above (or below) one milliwatt
FDX	Full-duplex
gnd	Ground
LVL	Level
mA	Milliampere
N/A	Not available/applicable
PCB	Plug-in component board
PMS	Planned Maintenance System
RCV	Receive
RFI	Radio frequency interference
RVS	Reverse Sense
S/R	Send/Receive
SIG	Signal
STBY	Standby
vf	Variable frequency
VOX	Voice operated transmitter keyer
VTVM	Vacuum tube voltmeter



## INDEX

	Paragraph (Figure) *Table
A	
Adjustments and Alignments	6-2
Front Panel Removal	6-2.1
High-Band Oscillator Frequencies	6-2.9
Low-Band Oscillator Frequencies	6-2.8
Meter Movements	6-2.4
Preliminary Setup	6-2.3
Receive Bias	6-2.5
Receive Delay	6-2.7
Send Delay	6-2.6
Test Equipment Required	*1-2
Adjustments, Initial Checks and	8-10
Adjustments, Signal Level	2-3.3
Application, Initial Power	8-9
Application, System	(1-2)
Assemblies, List of Major	*7-1, 7-2
B	
Back-to-Back Configuration	(5-1)
Bench Mounting	8-6.3
Block diagrams	
Detailed Overall	(3-2)
Functional	(2-1)
Simplified Overall	(3-1)
C	
Changes	
Factory	*1-5, 1-8
Field	*1-6, 1-8
Chassis Parts Location, Front Panel	(5-2)
Chassis Parts Location, Interior	(5-3)
Circuits	
Control	*3-1, (3-2), 3-2, 3-2.5, 3-9
Back-to-Back	3-9.5
Full Duplex	3-9.4
Functions	*3-1
Half Duplex	3-9.5
Network	3-9.1
Receive Only	3-9.2
Send Only	3-9.3
Frequency Discriminator	(3-3)

## INDEX (Continued)

	Paragraph (Figure) *Table
Loop Keying	3-2.4, 3-8
Meter	3-10
Power Supply	(3-1), 3-11, (5-6)
Product Detector	3-7
Receive Input	3-2.3, 3-6
Send Input	3-2.1, 3-4
Tone Keying	3-2.2, 3-5
Component Boards	
Fault Isolation Procedures	*5-1, 5-3.1
1A1, Parts Location Diagram	(5-4)
1A1, Wiring Diagram	(5-5)
1A1, Schematic Diagram	(5-6)
1A2, Wiring Diagram and Parts Location Diagram	(5-8)
1A2, Schematic Diagram	(5-9)
1A3, Wiring Diagram and Parts Location Diagram	(5-10)
1A3, Schematic Diagram	(5-11)
1A4, Wiring Diagram and Parts Location Diagram	(5-10)
1A4, Schematic Diagram	(5-11)
1A5, Wiring Diagram and Parts Location Diagram	(5-12)
1A5, Schematic Diagram	(5-13)
1A6, Wiring Diagram and Parts Location Diagram	(5-14)
1A6, Schematic Diagram	(5-15)
1A7, Parts Location Diagram	(5-16)
1A7, Schematic Diagram	(5-17)
1A8, Parts Location Diagram	(5-18)
1A8, Schematic Diagram	(5-19)
1A9, Parts Location Diagram	(5-18)
1A9, Schematic Diagram	(5-19)
Connections	(8-1), (8-2), *8-2, 8-4, 8-8
Control Circuit Functions	3-1, *3-1
Control Circuits Functional Description	3-9
Control Section	2-1.3
Controls and Indicators	*2-1, 2-2, (2-2)
Converter, Telegraph-Telephone Signal	(1-1)

## D

Data, Reference	*1-3, 1-5
Description	
Equipment	1-3

## INDEX (Continued)

	Paragraph (Figure) *Table
Functional	1-3.2
Physical	1-3.1
Detector, Product	3-7
Diagrams	5-3.2
Detailed Overall Block	(3-2)
Functional Block	(2-1)
Simplified Block	(3-1)
Dimensions, Mounting	(8-2)
E	
Emergency Maintenance	2-4.2
Equipment, Accessories and Documents Supplied	*1-1, 1-6
Equipment and Publications Required, But Not Supplied	*1-2, 1-3.3
F	
Failure Analysis	5-2.6
Fault Isolation	*5-1, 5-3.1
Frequency Discriminator Circuits	(3-3)
Front Panel Removal	6-2.1
Full Duplex	3-9.4
Functional Description	1-3.2
Functional Block Diagram	(2-1)
Functional Section Description	3-3
G	
(None)	
H	
Half-Duplex	3-9.6
High Band Oscillator Frequencies	6-2.9
I	
Initial Checks and Adjustments	8-10
Initial Power Application	8-9
Inspection, Visual	8-3
Installation, System	(8-1)
Instructions, Unpacking and Repacking	8-2

## INDEX (Continued)

	Paragraph (Figure) *Table
J	
(None)	
K	
Keying Circuits, Loop	3-2.4, 3-8
Keying Circuits, Tone	3-2.2, 3-5
L	
List of Major Assemblies	*7-1, 7-2
List of Manufacturers	7-4, *7-13
List, Maintenance Parts	7-3
Listing Probable Faulty Function	5-2.3
Localizing the Faulty Function	5-2.4
Localizing Trouble to the Circuit	5-2.5
Logical Troubleshooting	5-2
Low Band Oscillator Frequencies	6-2.8
M	
Maintenance	
Corrective	6-1
Emergency	2-4.2
Operator's	2-4, 4-2
Parts List	7-3
Preventive	2-4.1
Scheduled	4-3
Parts List for Module 1A1	*7-2
Parts List for Module 1A2	*7-3
Parts List for Module 1A3	*7-4
Parts List for Module 1A4	*7-5
Parts List for Module 1A5	*7-6
Parts List for Module 1A6	*7-7
Parts List for Module 1A7	*7-8
Parts List for Module 1A8	*7-9
Parts List for Module 1A9	*7-10
Parts List for Module 1A10	*7-11
Parts List for Module 1A11	*7-12
Major Assemblies, List of	*7-1, 7-2
Manufacturers, List of	7-4, *7-13
Meter Circuits	3-2.6, 3-10

## INDEX (Continued)

	Paragraph (Figure) *Table
Meter Movement	6-2.4
Mounting	8-6
Bench	8-6.3
Dimensions	(8-2)
Rack	8-6.2
N	
(None)	
O	
Operating Parameters	*1-4
Operating Procedure	2-3
Operation	2-3.1
Operator's Maintenance	2-4
Operator's Procedure	4-2.1
Options, Send and Receive	1-3.3
Options, Strapping	*8-1
Overall Functional Description	3-2
P	
Physical Description	1-3.1
Power Requirements	8-4
Power Supply	3-2.7, 3-11
Power Supply, Module 1A1, Parts Location	(5-4)
Power Supply, Module 1A1, Wiring Diagram	(5-5)
Power Supply, Module 1A1, Schematic Diagram	(5-6)
Preliminary Setup	6-2.3
Preventive Maintenance	2-4.1, 4-2
Product Detector	3-7
Q	
(None)	
R	
Rack Mounting	8-6.2
Receive Bias	6-2.5
Receive Delay	6-2.7
Receive Input Circuits	3-2.3, 3-6
Receive Section	2-1.2

INDEX (Continued)

	Paragraph (Figure) *Table
Record of Factory Changes	*1-5, 1-8
Record of Field Changes	*1-6, 1-8
Reference Data	*1-3, 1-5
Relationship of Units	1-4
Repair	6-3
S	
Safety Precautions	1-1
Scheduled Maintenance	4-3
Scheduled Performance Tests	4-4
Send Delay	6-2.6
Send Input Circuits	3-4
Simplified Overall Block Diagram	(3-1)
Site Selection	8-5
Strapping	(8-3), 8-7
Strapping Options	*8-1
System Application	(1-2)
System Installation	(8-1)
T	
Test Equipment Required	*1-2, 6-2.2
Tone Keying Circuits	3-2.2, 3-5
Troubleshooting Procedure	5-3
Turn-on Procedures	*2-2
U	
Units, Relationship of	1-4
Unpacking and Repacking Instructions	8-2
V	
Visual Inspection	8-3
W-X-Y-Z	
(None)	