

Cy # 2

NAVSHIPS 93803(A)

(Non-Registered)

0967-449-3010

TECHNICAL MANUAL

Mc
good for

ANTENNA COUPLER

CU - 872 / U

WESTINGHOUSE ELECTRIC CORPORATION
ELECTRONICS DIVISION FRIENDSHIP
P.O. Box 1897 Baltimore 3, Maryland

DEPARTMENT OF THE NAVY
BUREAU OF SHIPS

Faint stamp: ... Division Command



NAVSHIPS 93803(A)

(Non-Registered)

TECHNICAL MANUAL

for

ANTENNA COUPLER

CU - 872 / U

WESTINGHOUSE ELECTRIC CORPORATION
ELECTRONICS DIVISION FRIENDSHIP PLANT
P.O. Box 1897 Baltimore 3, Maryland

DEPARTMENT OF THE NAVY
BUREAU OF SHIPS

Contract: NObsr 81489

Approved by BuShips: 7 March 1961

LIST OF EFFECTIVE PAGES

PAGE NUMBERS	CHANGE IN EFFECT	PAGE NUMBERS	CHANGE IN EFFECT
Title Page	Original	4-1 to 4-6	Original
ii to vii	Original	5-1 to 5-6	Original
1-0 to 1-4	Original	6-1 to 6-10	Original
2-1 to 2-4	Original	7-1 to 7-18	Original
3-1 to 3-4	Original		



DEPARTMENT OF THE NAVY
BUREAU OF SHIPS
WASHINGTON 25, D. C.

IN REPLY REFER TO
Code 242-100

From: Chief, Bureau of Ships
To: All Activities concerned with the Installation, Operation,
and Maintenance of the Subject Equipment

Subj: Technical Manual for Antenna Coupler CU-872/U, NAVSHIPS 93803(A)

1. This is the Technical Manual for the subject equipment and is in effect upon receipt. It supersedes NAVSHIPS 93803. Upon receipt hereof, NAVSHIPS 93803 shall be destroyed by burning.
2. When superseded by a later edition, this publication shall be destroyed.
3. Extracts from this publication may be made to facilitate the preparation of other Department of Defense publications.
4. Errors found in this publication (other than obvious typographical errors), which have not been corrected by means of Temporary Corrections or Permanent Changes should be reported. Such report should include the complete title of the publication and the publication number (short title); identify the page and line or figure and location of the error; and be forwarded to the Electronics Publications Section of the Bureau of Ships.
5. All Navy requests for NAVSHIPS electronics publications listed in the current issue of NAVSANDA Publication 2002 "Requisitioning Guide and Index of Forms and Publications", Cognizance Symbol I, or in a subsequent issue of the Electronics Information Bulletin should be directed to the appropriate Forms and Publications Supply Point.

R. K. JAMES
Chief of Bureau

RECORD OF CORRECTIONS MADE

CHANGE NO.	DATE	FIELD CHANGE NO.	SIGNATURE

TABLE OF CONTENTS

SECTION 1. GENERAL INFORMATION

<u>Paragraph</u>		<u>Page</u>
1-1	Scope	1-1
1-2	Functional Description	1-1
1-3	Factory or Field Changes.....	1-1
1-4	Quick Reference Data	1-1
1-5	Equipment Lists	1-2
1-6	Equipment Similarities	1-3
1-7	Classified Information	1-3

SECTION 2. INSTALLATION

2-1	Unpacking and Handling.....	2-1
2-2	Power Requirements	2-1
2-3	Installation Layout	2-1
2-4	Interconnection	2-1
2-5	Cable Assembly	2-1
2-6	Inspection and Adjustments	2-3
2-7	Interference Reduction	2-3
2-8	Preparation for Reshipment	2-3

SECTION 3. OPERATOR'S SECTION

3-1	Functional Operation	3-1
3-2	Operating Procedure	3-1
	a. Description of Controls.....	3-1
	b. Operation	3-1
	c. Tuning Adjustments.....	3-1
3-3	Summary of Operating Procedures	3-1
3-4	Emergency Operation	3-1
3-5	Operator's Maintenance	3-2
	a. General	3-2
	b. Operating Checks and Adjustments	3-2
	c. Emergency Maintenance	3-2

SECTION 4. PRINCIPLES OF OPERATION

4-1	Overall Functional Description.....	4-1
4-2	Distributed Amplifier	4-1
4-3	Output Circuits	4-4
4-4	Monitoring Circuits	4-4
4-5	Power Supply	4-4

SECTION 5. TROUBLESHOOTING

5-1	General	5-1
5-2	Test Equipment and Special Tools	5-1
5-3	Troubleshooting	5-1
	a. Preliminary Check	5-1
	b. Test Equipment and Special Tools	5-1
	c. Control Settings	5-1
	d. Troubleshooting Chart	5-1

TABLE OF CONTENTS (Concluded)

SECTION 6. REPAIR

<u>Paragraph</u>		<u>Page</u>
6-1	Failure Report	6-1
6-2	Output Isolation Measurement	6-1
	a. General	6-1
	b. Test Equipment and Special Tools	6-1
	c. Special Jigs	6-1
	d. Control Settings	6-1
	e. Procedure	6-1
6-3	Adjustment of Coils L49 Through L52	6-2
	a. General	6-2
	b. Test Equipment and Special Tools	6-2
	c. Special Jigs	6-2
	d. Coil Replacement	6-2
	e. Coil Adjustment	6-2
6-4	Adjustment of Amplitude Response of Filter Z2	6-3
	a. General	6-3
	b. Test Equipment and Special Tools	6-3
	c. Special Jigs	6-3
	d. Procedure	6-3
6-5	Phase Adjustment	6-5
	a. General	6-5
	b. Test Equipment and Special Tools	6-5
	c. Special Jigs	6-5
	d. Procedure	6-6
6-6	Output Phasing Cable Replacement	6-7

SECTION 7. PARTS LIST

7-1	Introduction	7-1
7-2	Maintenance Parts List	7-1
7-3	Stock Number Identification	7-1
7-4	List of Manufacturers	7-1

LIST OF ILLUSTRATIONS

<u>Figure</u>		<u>Page</u>
SECTION 1. GENERAL INFORMATION		
1-1	Antenna Coupler CU-872/U	1-0
SECTION 2. INSTALLATION		
2-1	Antenna Coupler CU-872/U, Outline Drawing	2-2
2-2	Antenna Coupler CU-872/U, Interconnecting Diagram	2-3
SECTION 3. OPERATOR'S SECTION		
3-1	Antenna Coupler CU-872/U, Location of Controls	3-2
3-2	Antenna Coupler CU-872/U, Location of Tubes and Connectors	3-3

LIST OF ILLUSTRATIONS (Concluded)

<u>Figure</u>		<u>Page</u>
---------------	--	-------------

SECTION 4. TROUBLESHOOTING

4-1	Antenna Coupler CU-872/U, Functional Block Diagram	4-2
4-2	Antenna Coupler CU-872/U, Distributed Amplifier, Simplified Schematic Diagram	4-3
4-3	Antenna Coupler CU-872/U, Hybrid Output, Simplified Schematic Diagram	4-5

SECTION 5. TROUBLESHOOTING

5-1	Antenna Coupler CU-872/U, Locations of Test Points.....	5-2
-----	---	-----

SECTION 6. REPAIR

6-1	Antenna Coupler CU-872/U, Locations of Adjustments	6-5
6-2	Antenna Coupler CU-872/U, Typical Cable Assembly	6-7
6-3	Antenna Coupler CU-872/U, Schematic Diagram	6-9

LIST OF TABLES

<u>Table</u>		<u>Page</u>
--------------	--	-------------

SECTION 1. GENERAL INFORMATION

1-1	Antenna Coupler CU-872/U, Equipment Supplied	1-2
1-2	Antenna Coupler CU-872/U, Equipment and Publications Required but not Supplied.....	1-2
1-3	Antenna Coupler CU-872/U, Shipping Data.....	1-3
1-4	Antenna Coupler CU-872/U, Electron Tube Complement	1-3

SECTION 3. OPERATOR'S SECTION

3-1	Antenna Coupler CU-872/U, Function of Controls	3-1
3-2	Operator's Maintenance	3-4

SECTION 5. TROUBLESHOOTING

5-1	Antenna Coupler CU-872/U, Troubleshooting Chart	5-3
5-2	Antenna Coupler CU-872/U, Voltage and Resistance Chart	5-4
5-3	Antenna Coupler CU-872/U, Typical Troubles	5-5

SECTION 7. PARTS LIST

7-1	Antenna Coupler CU-872/U, Maintenance Parts List	7-2
7-2	Antenna Coupler CU-872/U, Lists of Manufacturers	7-17

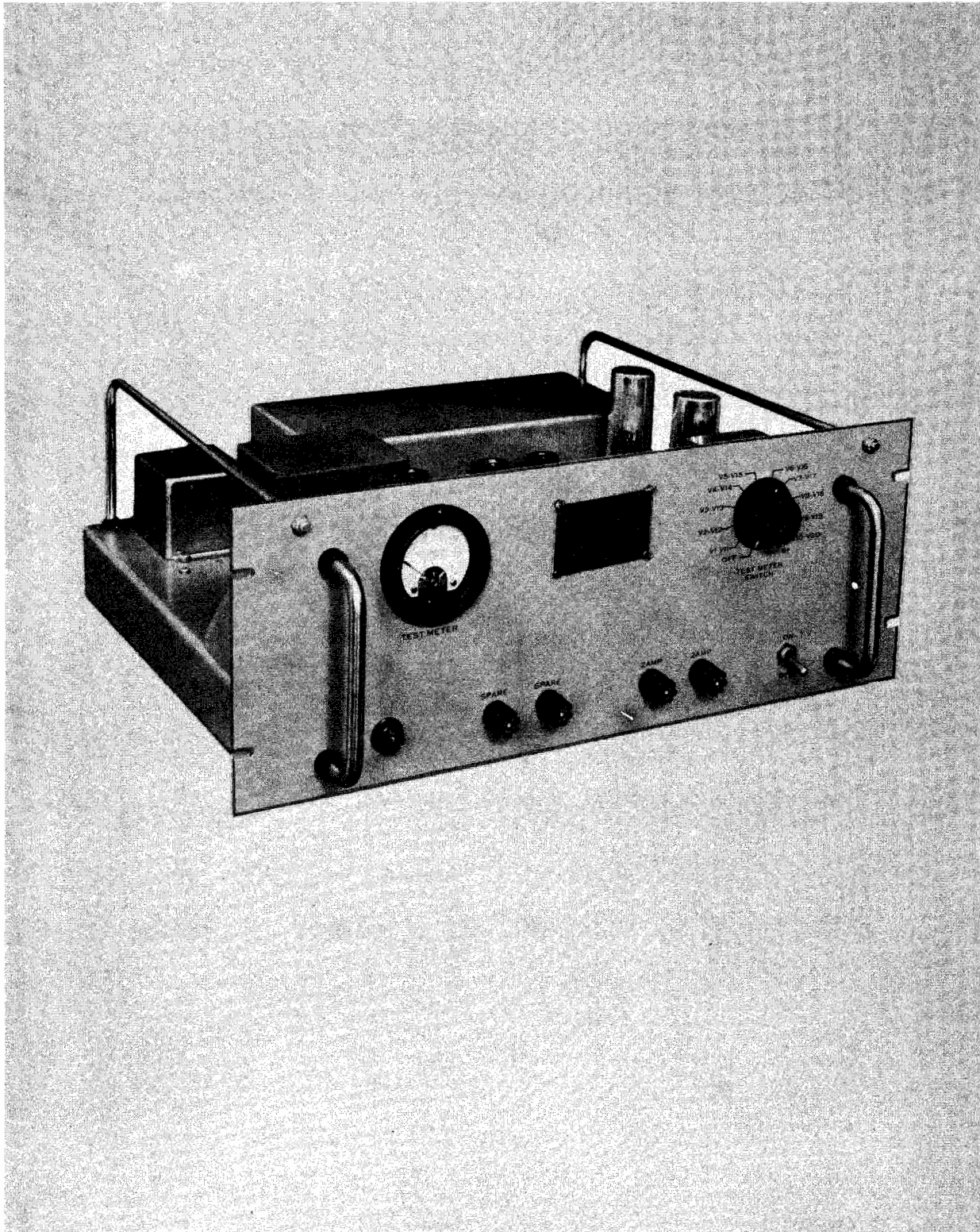

Figure 1-1. Antenna Coupler CU-872/U

SECTION 1

GENERAL INFORMATION

1-1. SCOPE.

This manual covers the description, installation, operation and maintenance for Antenna Coupler CU-872/U. The overall view is shown in figure 1-1. Instructions for government-furnished materials (GFM) are not discussed in this manual.

1-2. FUNCTIONAL DESCRIPTION.

Antenna Coupler CU-872/U provides optimum coupling between a single antenna and as many as eight receivers. Design considerations include selection of circuits and choice of components providing a low voltage standing wave ratio, a wide frequency range (2.0 mc through 32 mc), a high attenuation of out of band frequencies, a minimum noise figure, minimum intermodulation, a high degree of isolation between individual outputs, an overall power gain and high reliability.

1-3. FACTORY OR FIELD CHANGES.

At the time of this publication no factory or field changes have been accomplished on this equipment.

1-4. QUICK REFERENCE DATA.

a. FREQUENCY RANGE.—Antenna Coupler CU-872/U provides a wide frequency range between the values of 2.0 mc and 32 mc.

b. INPUT AND OUTPUT CHARACTERISTICS.—Antenna Coupler CU-872/U matches a 70-ohm input and output impedance. The input is obtained through one Type N connector located at the rear of the unit. The output is provided through eight Type N connectors located at the rear of the unit.

c. NUMBER OF OUTPUTS.—Eight outputs are provided for at the rear of the unit.

d. INTERMODULATION.—The intermodulation products of two 0.25-volt signals applied at the input are down 60 db.

e. ISOLATION OF OUTPUTS.—Minimum isolation between any two outputs is 40 db.

f. GAIN.—This unit provides a gain of 2 db \pm 0 to 3 db within the frequency range of from 2.0 mc to 32 mc.

g. PHASE.—The phase difference between any two outputs of one antenna coupler does not exceed \pm 2 degrees over the operating frequency range of 2 mc to 32 mc. The phase difference between all outputs of all antenna couplers of a given production run will not exceed \pm 2 degrees over the operating range of 2 mc to 32 mc.

h. ANTENNA CHARACTERISTICS.—The antenna (GFM) should have a VSWR of less than 3:1 over the band of 2.0 to 32 mc for best performance.

i. AMBIENT TEMPERATURE LIMITATIONS.—The ambient operating temperature limitations range from 0°C (+32°F) to +50°C. (+122°F.)

j. POWER SUPPLY CHARACTERISTICS.—Antenna Coupler CU-872/U requires a voltage supply of 115 \pm 11.5 volts or 230 \pm 23 volts, 48 to 62 cps, single phase, 125 watts (approximate).

k. NOISE FIGURE.—Antenna Coupler CU-872/U has a noise figure of 6 db or better.

1. **CASCADE OPERATION.**—Additional antenna connections may be obtained by connecting the antenna couplers in cascade with a resultant increase in signal gain of 0 to 3 db. The effective noise figure of two cascaded antenna couplers will be 7.7 db or better.

1-5. **EQUIPMENT LISTS.**

Equipment supplied for the Antenna Coupler CU-872/U are listed in table 1-1. Equipment and publications required but not supplied are listed in table 1-2. Shipping data is provided in table 1-3. Electron tube complement is listed in table 1-4.

TABLE 1-1. ANTENNA COUPLER CU-872/U, EQUIPMENT SUPPLIED

Quant. per Equip.	Nomenclature		Overall Dimensions*			Volume*	Weight*
	Name	Designation	Height	Width	Depth		
1	Antenna Coupler	CU-872/U	7	19	16-1/2	1.27	33
9	Connectors	UG-21B/U	13/16	13/16	1-7/8		0.123
1	Connector	AN3106A-14S-7S	1-1/8	1-1/8	1-7/16		
1	Technical Manual	NAVSHIP 93803(A)	11-1/2	9			

*Unless otherwise stated, dimensions are in inches, volume in cubic feet, weight is in pounds.

TABLE 1-2. ANTENNA COUPLER CU-872/U, EQUIPMENT AND PUBLICATIONS REQUIRED BUT NOT SUPPLIED

Quant. per Equip.	Nomenclature		Required Use	Required Characteristics
	Name	Designation		
1	Adapter	UG-107B/U	Provides for simultaneous connection of a vacuum-tube voltmeter and signal generator to ANTENNA INPUT connector J9.	
1	High Frequency Signal Generator and Instruction Manual	Hewlett-Packard 606A	Supplies a test signal for determination of output 1 selection and gain.	Must generate signals between 1.0 mc and 58 mc.
1	Multimeter and Technical Manual	AN/USM-34 Series NAVSHIPS 92197	Monitors output voltage of RF Signal Generator Sets.	Must measure r-f, a-c and d-c voltages.
1	Radio Test Set and Technical Manual	AN/PRM-1 Series NAVSHIPS 91255	Serves as a selective r-f voltmeter.	Must be selective over the 1-mc to 25-mc band.
1	Radio Interference Measuring Set	AN/URM-47 Series NAVSHIPS 92147	Serves as a selective r-f voltmeter	Must be selective over the 25-mc to 58-mc band.
1	Phase Meter (vectorlizer)	Advanced Electronics Lab Inc. TYPE 202	Precision Phase Measurements	

TABLE 1-2. ANTENNA COUPLER CU-872/U, EQUIPMENT AND PUBLICATIONS REQUIRED BUT NOT SUPPLIED-- (Concluded)

Quant. per Equip.	Nomenclature		Required Use	Required Characteristics
	Name	Designation		
Up to 8	Radio Receivers			
1	Antenna		To provide input to Antenna Coupler.	Must operate with a vswr of less than 3:1.

TABLE 1-3. ANTENNA COUPLER CU-872/U, SHIPPING DATA

Box No.	Nomenclature		Overall Dimensions*			Volume*	Weight*
	Name	Designation	Height	Width	Depth		
1	Antenna Coupler	CU-872/U	10	21	19	2.3	40

*Unless otherwise noted, dimensions are in inches, volume in cubic feet and weight in pounds; equipment crated and ready for shipment.

TABLE 1-4. ANTENNA COUPLER CU-872/U, ELECTRON TUBE COMPLEMENT

UNIT	Number of Tubes of Types Indicated		
	6922	OB2WA	TOTAL
Antenna Coupler CU-872/U	20	1	21

1-6. EQUIPMENT SIMILARITIES.

Antenna Coupler CU-872/U is electrically similar to Antenna Couplers CU-656/U, CU-873/U and CU-874/U.

1-7. CLASSIFIED INFORMATION.

This technical manual contains no classified information.



SECTION 2
INSTALLATION

2-1. UNPACKING AND HANDLING.

This unit has been packed at the factory and prepared for domestic shipment. This equipment should be stored in an upright position. Care should be exercised while unpacking and handling to prevent damage. No special tools are required to open the packing case.

CAUTION

DO NOT USE HOOKS WHILE HANDLING THIS UNIT. DO NOT REMOVE THE PROTECTIVE PACKING AROUND THE CONTROLS AND METER UNTIL THE UNIT HAS BEEN SECURED.

2-2. POWER REQUIREMENTS.

Antenna Coupler CU-872/U requires 115 volts or 230 volts, 50 to 60 cps, single phase, 125 watts (approximate).

2-3. INSTALLATION LAYOUT.

The unit is designed to be placed in a standard 19-inch rack. The choice of location is not critical but it is advisable that the unit be at a distance from any high power equipment. The outline drawing with dimensions is shown in figure 2-1.

2-4. INTERCONNECTION.

Interconnections of this unit are shown in figure 2-2. It should be noted that no terminating caps are required on the output connectors in the event that less than the maximum number of receivers are used (eight receivers). All connections should be made carefully in order to obtain maximum coupling.

2-5. CABLE ASSEMBLY.

a. The interconnection diagram, figure 2-2, shows the type of coaxial connector termination necessary for all coaxial cable interconnection. For proper assembly of connectors to coaxial cables, follow the procedures in Armed Forces Index of R.F. Transmission Lines and Fittings, NAVSHIPS 900102B.

b. The termination of the power cable is accomplished in the following procedure:

Step 1. Determine the radius on which the conductors are to be fanned out and cut away armor and outer cover to a distance of the fanning plus approximately 0.75 inches.

Step 2. Slide on the cable clamp, brass nickel plated washer, rubber washer, back shell and retainer ring in successive order.

Step 3. Put leads through the holes in the socket rear insert.

Step 4. Strip wires to the exact length of the soldering section of the socket contact and solder in place.

Step 5. Attach the socket from insert and the front shell.

Step 6. Screw the cable clamp and back shell together.

Step 7. Attach the cable clamp cap to the cable clamp by means of the clamp screw and lock washers.

Figure 2-1

NAVSHIPS 93803(A)

CU-872/U
INSTALLATION

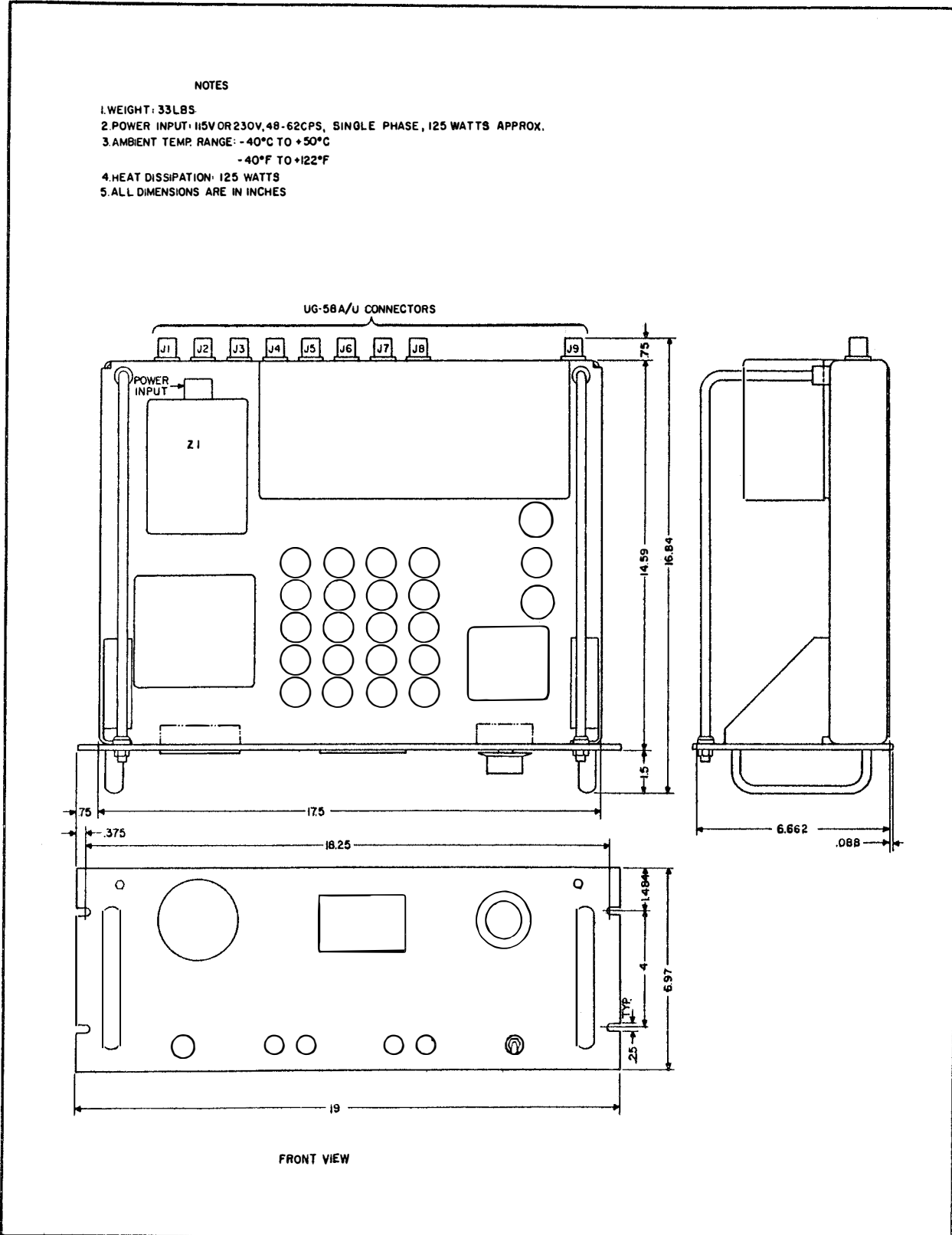

Figure 2-1. Antenna Coupler CU-872/U, Outline Drawing

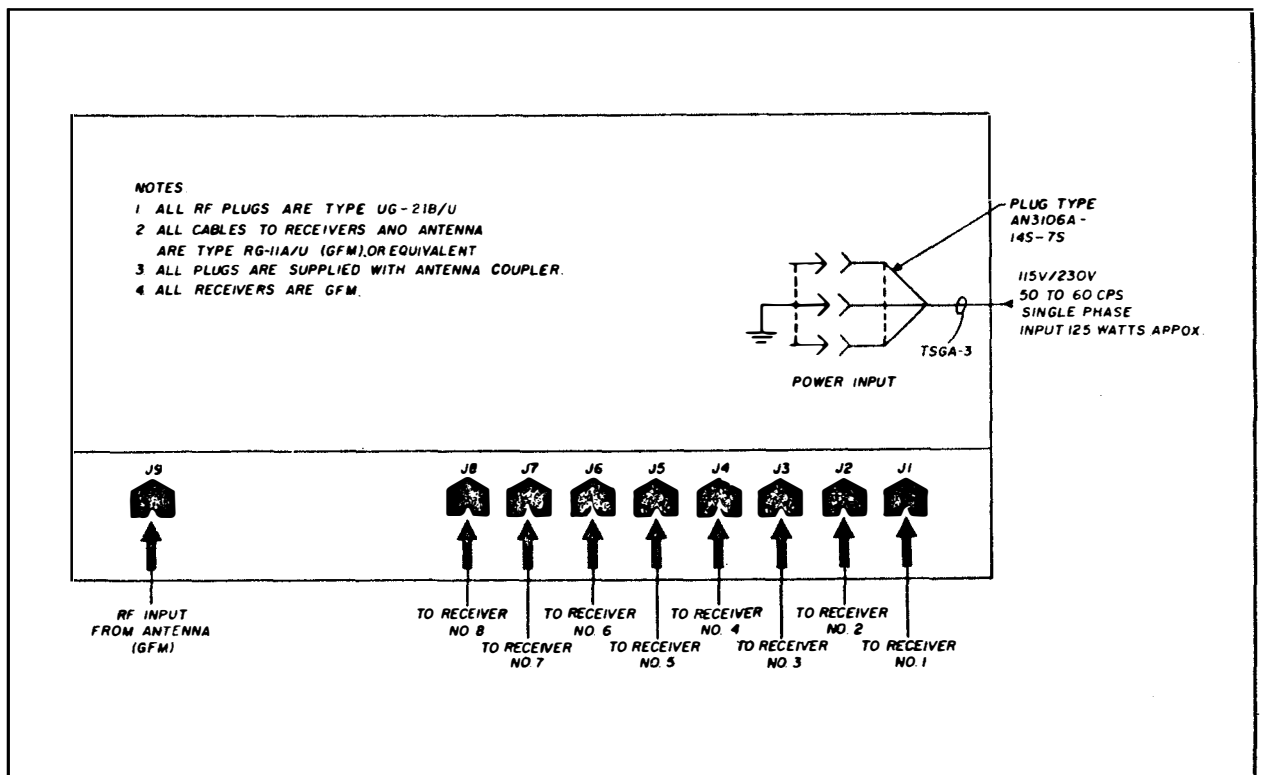

Figure 2-2. Antenna Coupler CU-872/U, Interconnecting Diagram

2-6. INSPECTION AND ADJUSTMENTS.

a. Before inspection make sure that the unit is deenergized. Then make the following inspections.

Step 1. Check all coaxial cables to see whether they are in the proper connector and that all connections are secure.

Step 2. Check the ON-OFF switch and the TEST METER SWITCH for damage and the TEST METER for a broken glass cover or signs of damage. Make sure that the two fuses on the front panel and the indicating lamp are intact and not open

Step 3. Check all tubes for signs of damage and proper seating in sockets.

b. Set for proper line voltage by use of the 115/230-volt straps.

2-7. INTERFERENCE REDUCTION.

In order to reduce interference the unit should be moderately shielded and located at a distance from high power equipment.

2-8. PREPARATION FOR RESHIPMENT.

Disconnect all external connections. Remove all connectors from the coaxial cables and power cord. Place the connectors in a bag and tie it to the chassis. Place unit in container along with the two technical manuals; and packing material to prevent the unit from shifting and seal the container.



SECTION 3
OPERATOR'S SECTION

3-1. FUNCTIONAL OPERATION.

Antenna Coupler CU-872/U can provide optimum coupling between a single antenna and as many as eight receivers. Additional antenna connections may be obtained by connecting the antenna couplers in cascade. No operating procedure other than energizing the unit is required. Each of the eight receivers (GFM) may be tuned to any frequency within the pass band (2.0 mc to 32 mc) of the antenna coupler. Due to a design feature of this unit, terminating caps on the output terminals are not required if less than eight outputs are used.

3-2. OPERATING PROCEDURE.

a. DESCRIPTION OF CONTROLS.—The function of the various controls and connectors located on the Antenna Coupler CU-872/U are tabulated in table 3-1. Location of the various controls and connectors are shown in figure 3-1.

TABLE 3-1. ANTENNA COUPLER CU-872/U, FUNCTION OF CONTROLS

NAME	FUNCTION
ON-OFF (Switch)	Applies 115/230-volts a-c power to Antenna Coupler CU-872/U when placed in the ON position.
ON (Lamp)	Lights to indicate that power is applied to the unit.
2 AMP (Fuse)	Protects primary winding of transformer T11.
ANTENNA INPUT (Connector)	In put connection for 70-ohms antenna.
OUTPUTS 1-8 (Connectors)	Output connections for as many as eight receivers.
TEST METER SWITCH	V1-V11 through V10-V20 positions: applies the self-bias voltage of the named tubes to the TEST METER. B+ position: applies power supply output voltage to the TEST METER.
TEST METER	Monitors either the self-bias voltages of the cascode amplifier or the power supply output voltage depending on the position of the TEST METER SWITCH.

b. OPERATION.—Normal operation requires only that the unit be energized by placing the ON-OFF switch in the ON position.

c. TUNING ADJUSTMENTS.—There are no tuning adjustments.

3-3. SUMMARY OF OPERATING PROCEDURES.

Energize the unit by placing the ON-OFF switch in the ON position. Periodically record readings on the TEST METER through all positions of the TEST METER SWITCH.

3-4. EMERGENCY OPERATION.

In the event of tube failure, rotate the TEST METER SWITCH through positions V1-V11 through V10-V20 to locate the defective stage. Remove one of the two tubes which relate to the particular stage and replace with one known to be good. If stage is still defective, replace the tube removed, and interchange the new tube with the second tube of the stage. For example: if the TEST METER SWITCH indicated that the defective stage is V2-V12, remove tube V2 and replace with a new tube.

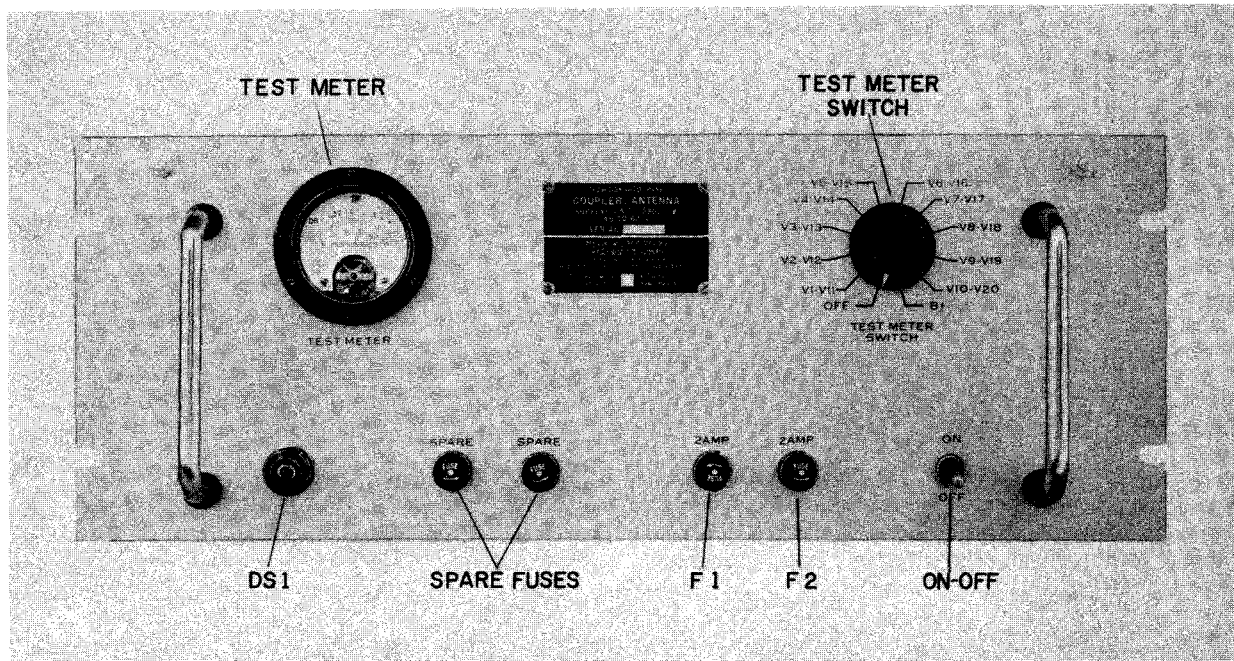

Figure 3-1. Antenna Coupler CU-872/U, Location of Controls

Then, if necessary, return the old V2 to its socket and replace V12 with the new tube. Locations of tubes are shown in figure 3-2.

3-5. OPERATOR'S MAINTENANCE.

a. **GENERAL.**—All tubes can be removed, checked and replaced if necessary. Fuses can be checked and replaced if necessary. If the **TEST METER** readings are logged periodically many troubles can be located before the unit is rendered inoperative.

b. **OPERATING CHECKS AND ADJUSTMENTS.**—It is recommended that certain routine checks be performed by the operating personnel as part of the operational maintenance program. The **TEST METER SWITCH** should be periodically placed in each of the eleven monitoring positions and corresponding indications on the **TEST METER** observed and recorded. The indications for positions V1-V11 through V10-V20 should be 33 ± 3 microamperes, and the indication in the B+ position should be 28 ± 3 microamperes. Upon completion of the prescribed checks, the results should be logged. These entries are of prime importance for they indicate whether or not the equipment is operating at maximum efficiency. Comparison of a given reading with previous readings will quickly reveal any significant change. It is expected that the readings will show nominal variations from time to time. This does not necessarily mean that the unit is operating improperly. If, however, a particular reading varies progressively in the same direction every time a check is made, it is an indication of improper operation or impending failure; and corrective measures should be taken.

c. **EMERGENCY MAINTENANCE.**—The various emergency maintenance operations are tabulated in table 3-2.

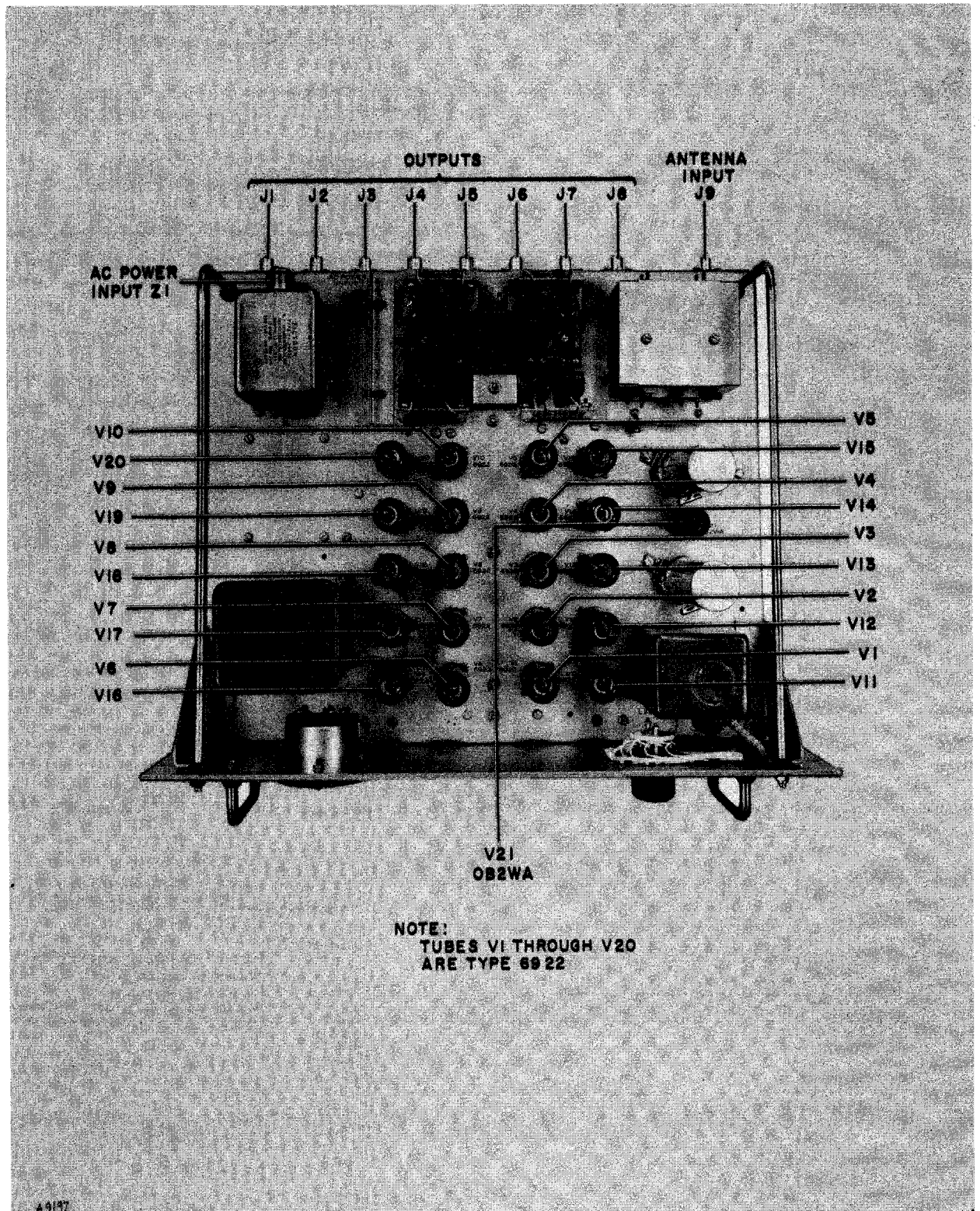

Figure 3-2. Antenna Coupler CU-872/U, Location of Tubes and Connectors

TABLE 3-2. OPERATOR'S MAINTENANCE

MALFUNCTION	INDICATION	REMEDY
Power Failure	ON light is not illuminated. No power to receiver.	<ol style="list-style-type: none">1. Check power at the source.2. Check ON lamp. Replace if necessary.3. Place ON-OFF switch in OFF position.4. Check fuses on front panel. Replace if necessary with same value fuse.
Tube Failure	TEST METER reading varies progressively in one direction.	<ol style="list-style-type: none">1. Locate defective stage by use of the TEST METER SWITCH.2. Replace each tube, in turn, with a new tube. See paragraph 3-4.

SECTION 4

PRINCIPLES OF OPERATION

4-1. OVERALL FUNCTIONAL DESCRIPTION.

Antenna Couple CU-872/U is designed to provide optimum coupling between a single antenna and as many as eight receivers in communications systems. Additional outputs are possible by connecting antenna couplers in cascade. A functional block diagram of the Antenna Couple CU-872/U is shown in figure 4-1. A 70-ohm input impedance is provided to match the impedance from the antenna. From the input connector the signal is fed to low pass-high pass filters. These filters pass only the frequencies in the spectrum between 2.0 mc and 32 mc. Transformer T1 in the output circuit of the low pass-high pass filters provides a transition between the low impedance unbalanced input circuits and a relatively high impedance balanced line. Each side of the balanced line drives one section of the push-pull distributed amplifier.

Tubes V1 through V5, tubes V11 through V15 and their associated circuitry comprise one-half of the push-pull distributed amplifier. Tubes V6 through V10, tubes V16 through V20 and their associated circuitry comprise the other half of the push-pull distributed amplifier. The distributed amplifier sections employ cascode stages along artificial transmission lines to obtain amplification over a wide bandwidth. The cascode amplifiers aid in reducing intermodulation by minimizing odd harmonic distortion. Additionally, employment of the distributed amplifier results in an improved signal-to-noise ratio. The distributed amplifier sections drive transformer T2 in a push-pull manner, thereby reducing intermodulation by minimizing even harmonic distortion. The resulting signal developed across the secondary winding of transformer T2 is applied to a cascaded hybrid network which distributes the amplified signal to eight isolated outputs.

4-2. DISTRIBUTED AMPLIFIER.

a. A low-loss artificial transmission line (consisting of odd numbered inductors L1 through L21 and odd numbered capacitors C41 through C59) is connected in the grid circuits of cascode amplifiers V1 through V5. The odd numbered capacitors C41 through C59 are shunted by the interelectrode capacitance from grid-to-cathode of the respective tube sections. The value of the inductors, and capacitors and the interelectrode capacitance from grid to cathode determines the impedance and cut-off frequency of the line. Resistor R93 terminates the line in its characteristic impedance. Capacitor C62 provides an r-f ground for the termination and d-c isolation for the grid circuits. A second low-loss artificial transmission line is formed in the plate circuit of the cascode amplifier by making use of their plate-to-cathode capacitance and inductors L27 through L37. Since the transmission lines are designed to have identical velocities of propagation, the individual sections of each transmission line shift the phase of signals equal amounts. The input signal appearing across the balanced secondary winding of transformer T1 is propagated along the artificial transmission line located in the grid circuits of the cascode amplifiers. As the signal arrives at the grids of each stage it influences the plate current of the tubes, resulting in the transmission of the signal in both directions along the plate artificial line. Waves traveling in the reverse direction are absorbed by terminating resistor R92. Waves traveling in the forward direction tend to add in phase. As a result the signal voltage at the output, which is equal to the sum of the in-phase signals, is proportional to the number of cascode amplifier stages; therefore, the signal power is proportional to the square of the number of cascode amplifier stages.

b. The signal-to-noise ratio is improved in the following manner. Noise due to shot effect is independently generated within each tube. The resulting noise voltages appearing along the plate artificial line add randomly; hence, the total noise power is proportional to the number of tubes. Since the output signal power is proportional to the square of the number of tubes, there is an overall improvement in noise figure over that of a single section. As a result, the distributed amplifier improves the signal-to-noise ratio.

c. Since the circuits of the five push-pull distributed amplifier sections shown in figure 6-1 are identical, only the section consisting of tubes V5, V15, V10, V20 and their associated circuits will be discussed. A simplified schematic of the fifth section of the distributed amplifier is shown in figure 4-2.

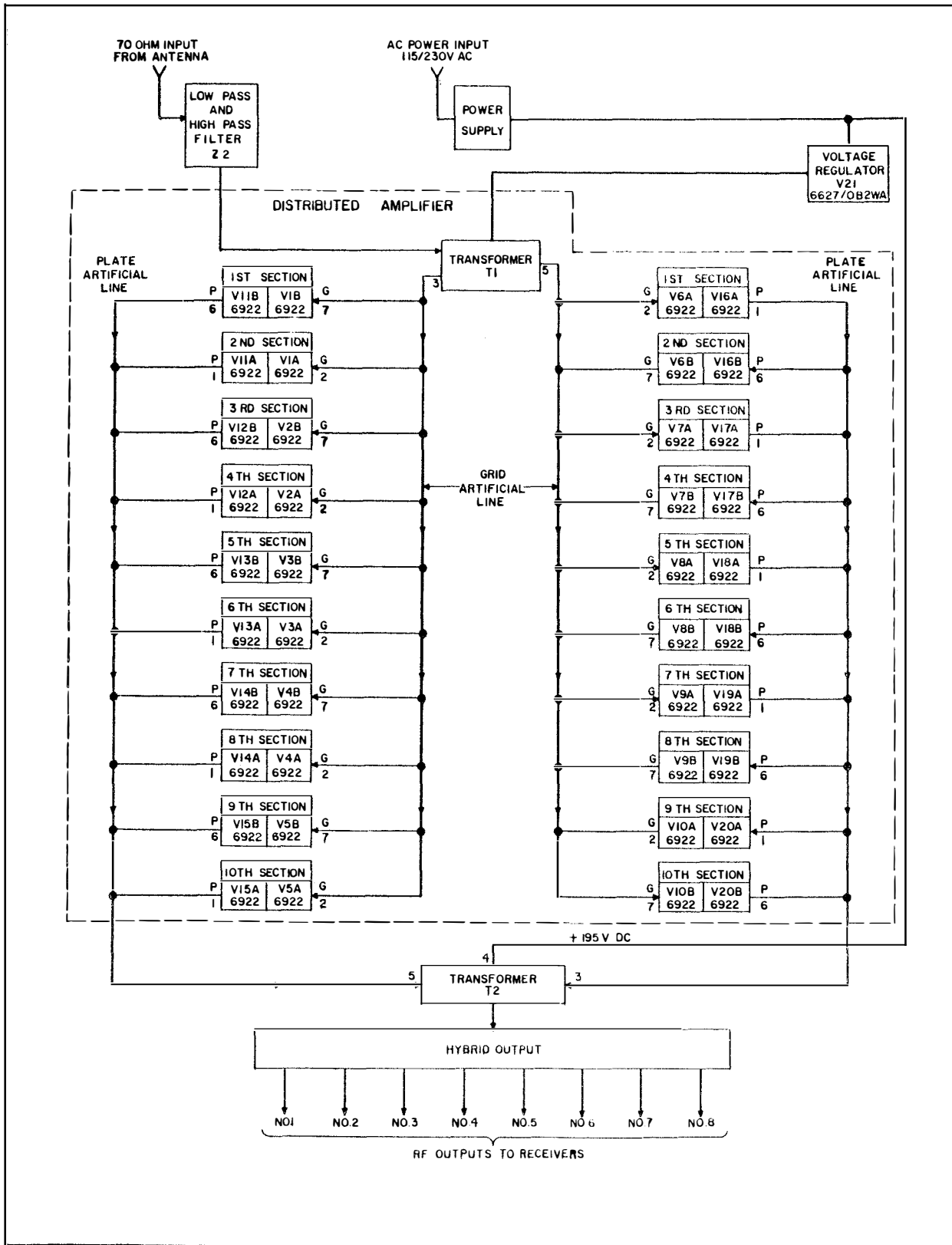

Figure 4-1. Antenna Coupler CU-872/U, Functional Block Diagram

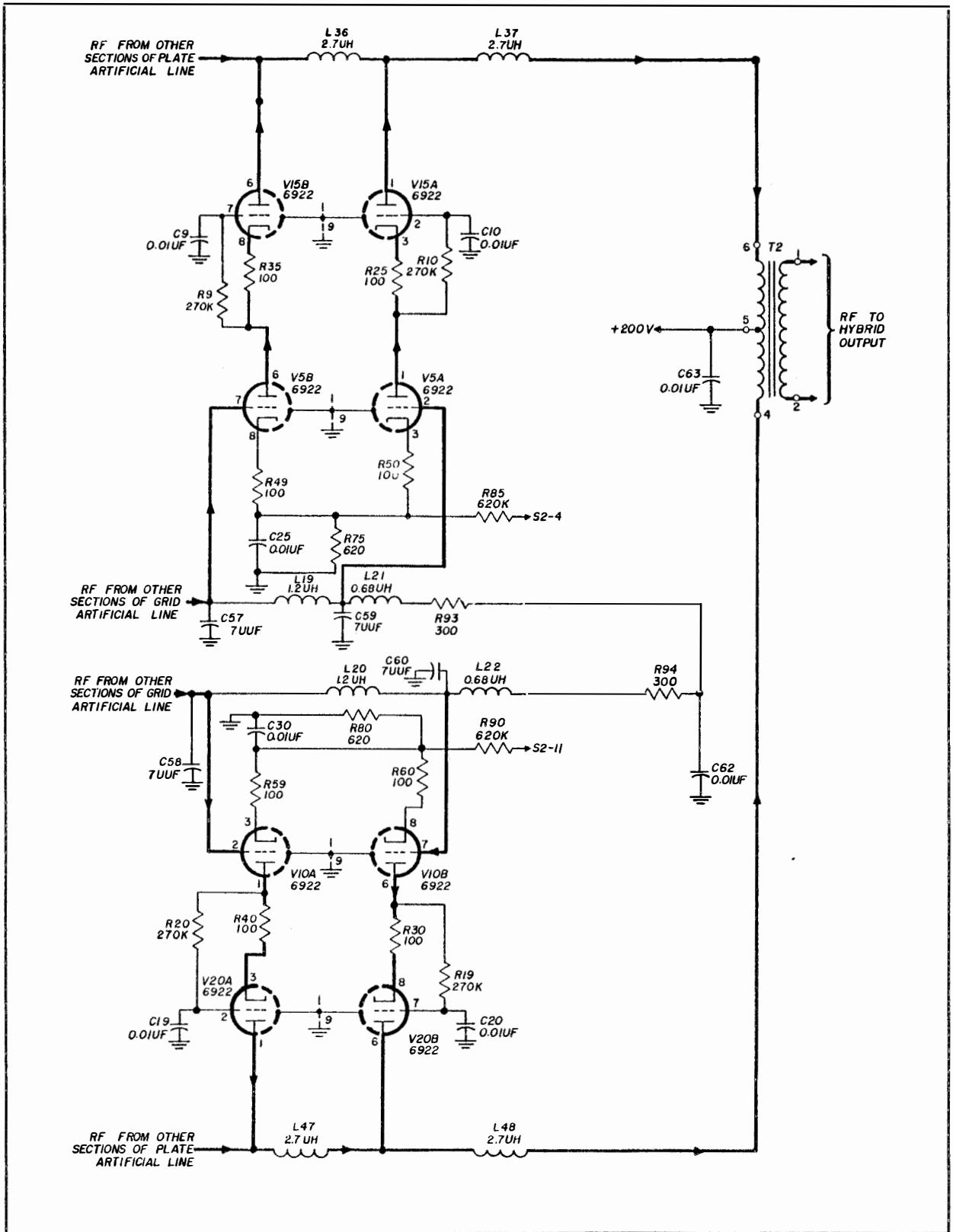

Figure 4-2. Antenna Coupler CU-872/U, Distributed Amplifier, Simplified Schematic Diagram

ORIGINAL

d. Tubes V5 and V15 function as a cascode amplifier. Negative feedback, which increases linearity of the cascode amplifier, is introduced by resistors R49 and R50, located in the cathode circuit of V5. The quiescent operating point of V5 is stabilized by employing a combination of self bias and fixed bias. The fixed bias, applied in opposition to the self bias, allows the use of a self bias resistor with a relatively high value. The self bias is developed by the paralleled circuit consisting of capacitor C25 and resistor R75. Due to the relatively high resistance of R75, a change in quiescent current is opposed by the consequent bias developed across the resistor. The operation of the preceding stages are identical to that of V5 and V15. Tubes V10 and V20 complete the push-pull circuit of the fifth section distributed amplifier and are identical in operation to tubes V5 and V15. The output is developed across transformer T2 for coupling to the hybrid output.

4-3. OUTPUT CIRCUITS.

a. The outputs are taken from a transformer hybrid resistive terminated network. For clarity, the circuit components of the hybrid output are rearranged into a bridged-bridge network as shown in figure 4-3.

b. The plate artificial lines of each of the distributed amplifier sections provide a push-pull drive for transformer T2. The resulting signal appears across the secondary winding of transformer T2 and is applied to a cascaded hybrid network which effects a power division of eight outputs with a high degree of isolation. The cascaded hybrid is comprised of both resistance hybrids (Wheatstone bridges) and transformer hybrids. Resistors R101 and R102 each serve as an arm of the primary bridge network. Resistor R100 serves as a balance termination. The remaining two arms contain the secondary bridge networks. Resistors R95 and R98 each serve as an arm and resistor R97 serves as the balance termination in one secondary bridge network. The remaining arms of this secondary bridge network are each comprised of a two-core type transformer hybrid. One transformer hybrid consists of transformers T3 and T4 and resistor R99 which serves as the balance termination. The other transformer hybrid consists of transformers T5 and T6 and resistor R96 which serves as the balance termination. The other secondary bridge network has resistors R103 and R106 each serving as an arm and resistor R105 which serves as the balance termination. The remaining two arms are each comprised of a two-core type transformer hybrid. One transformer hybrid contains transformers T7 and T8 and resistor R107 as the balance termination, the other contains transformers T9 and T10 and resistor R104 as the balance termination. The power available at each output is 15 db below the power input. The division of power to eight outputs accounts for a 9-db loss, and a 6-db power loss occurs in the two links of resistance bridges. Each of the eight output circuits has a nominal impedance of 70 ohms. Coils L49, L50, L51 and L52 add inductance to their respective hybrid circuits to maintain the correct impedance matching in the frequency band of 28 to 32 mc. Below 28 mc the inductance of these coils is too small to have any affect on the circuit.

4-4. MONITORING CIRCUITS.

a. Antenna Coupler CU-872/U incorporates circuitry which may be used to monitor the cathode current of each pair of cascode amplifiers and the output voltage of the power supply. The monitoring circuitry consists of TEST METER (M1), the 12-position TEST METER SWITCH (S2), meter multipliers R81 through R90, meter multiplier R115 and a voltage monitoring resistor R114.

b. When the TEST METER SWITCH is placed in any one of the positions V1-V11 through V10-V20, the self-bias voltage developed by the respective amplifier is indicated on the TEST METER. When the TEST METER SWITCH is placed in the B+ position, the relative power supply output voltage is indicated on the TEST METER.

4-5. POWER SUPPLY.

The power supply requires an input of 115 volts or 230 volts, 50 to 60 cps, single phase. The a-c voltage appearing across the secondary winding of transformer T11 is rectified by metallic rectifiers CR1 through CR4 which are connected as a full-wave bridge circuit. The d-c output voltage is applied to an L-section filter consisting of inductor L26 and capacitor C72, which attenuates the a-c ripple component. Voltage regulator V21 maintains a regulated voltage across the voltage divider network, consisting of resistors R110 and R111, which supplies a positive bias voltage of approximately 20 volts dc to the grids of cascode amplifiers V1 through V10.

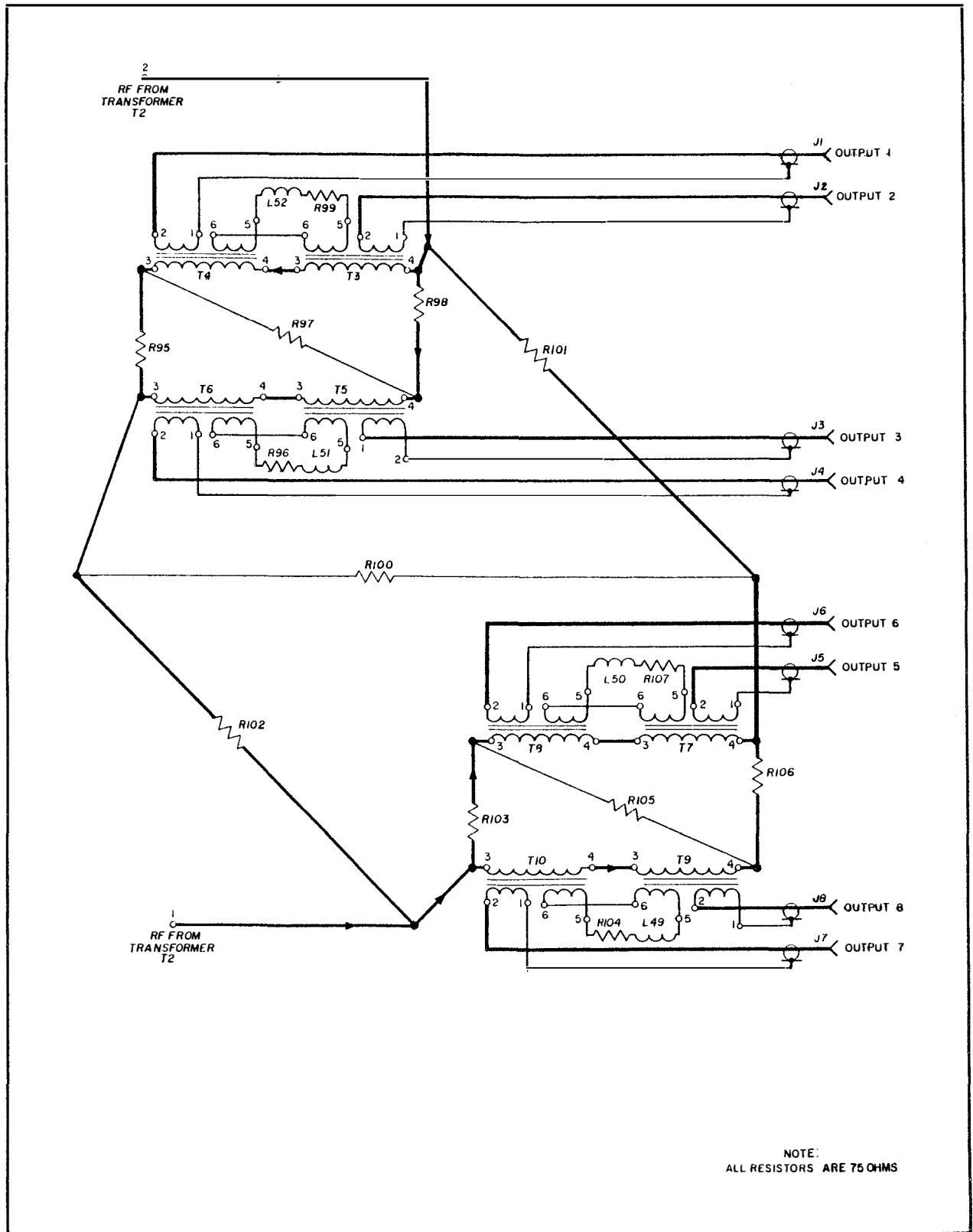

Figure 4-3. Antenna Coupler CU-872/U, Hybrid Output, Simplified Schematic Diagram

ORIGINAL

4-5
 4-6



SECTION 5
TROUBLESHOOTING

5-1. GENERAL.

a. This section presents troubleshooting procedures for Antenna Coupler CU-872/U. In order to aid the technician in localizing troubles quickly the following tables are included:

- Table 5-1. Troubleshooting Chart.
- Table 5-2. Voltage and Resistance Chart.
- Table 5-3. Typical Troubles.

b. The most practical method of localizing troubles in this unit is to use the troubleshooting chart. This chart reveals the preliminary action and normal indication along with the next step. If an abnormal condition is encountered during the outlined procedure, the corrective action can be taken without further reference.

c. A system of test points has been established to facilitate troubleshooting. The test points are shown on the overall schematic, figure 6-1, and the physical locations are shown in figure 5-1. The test points fall in two categories: major and secondary. Each major test point is identified by an encircled Arabic numeral enclosed in a star. Starred numerals are used to identify points for checking overall performance including the signal input and output terminals. Each secondary test point is identified by an encircled capital letter. Circled letters are used to identify circuit supply voltage terminals and points for measuring gain.

5-2. TEST EQUIPMENT AND SPECIAL TOOLS.

No special tools are necessary for troubleshooting the Antenna Coupler CU-872/U. Although specific types of equipment are listed here, the troubleshooting can be accomplished with the use of other test equipment. These specific test equipments are listed because they fall in the category of standard Navy test equipments that are located at most naval locations. The recommended test equipments are:

1. HF Signal Generator Hewlett-Packard 606A (or equivalent).
2. Multimeter AN/USM-34 Series (or equivalent).
3. Radio Interference Measuring Set AN/URM-47 Series (or equivalent).
4. Radio Test Set AN/PRM-1 Series (or equivalent).
5. Adapter UG-107/B.

5-3. TROUBLESHOOTING.

a. PRELIMINARY CHECK.—Improper operation of electronic equipment can often be quickly located by visual inspection. Antenna Coupler CU-872/U is equipped with an ON light that should be lighted when the unit is operating. By rotating the TEST METER SWITCH (S2) through its various positions and observing TEST METER (M1), a quick check of all the stages can be made.

b. TEST EQUIPMENT AND SPECIAL TOOLS.—Test equipment and special tools are listed in paragraph 5-2.

c. CONTROL SETTINGS.—The only control required to be set is the ON-OFF switch which is placed in the ON position.

d. TROUBLESHOOTING CHART.—The chart in Table 5-1 is a systematic check to be used when trouble arises. The test points appearing in the column marked TEST POINTS are located on figures 5-1 and 6-1.

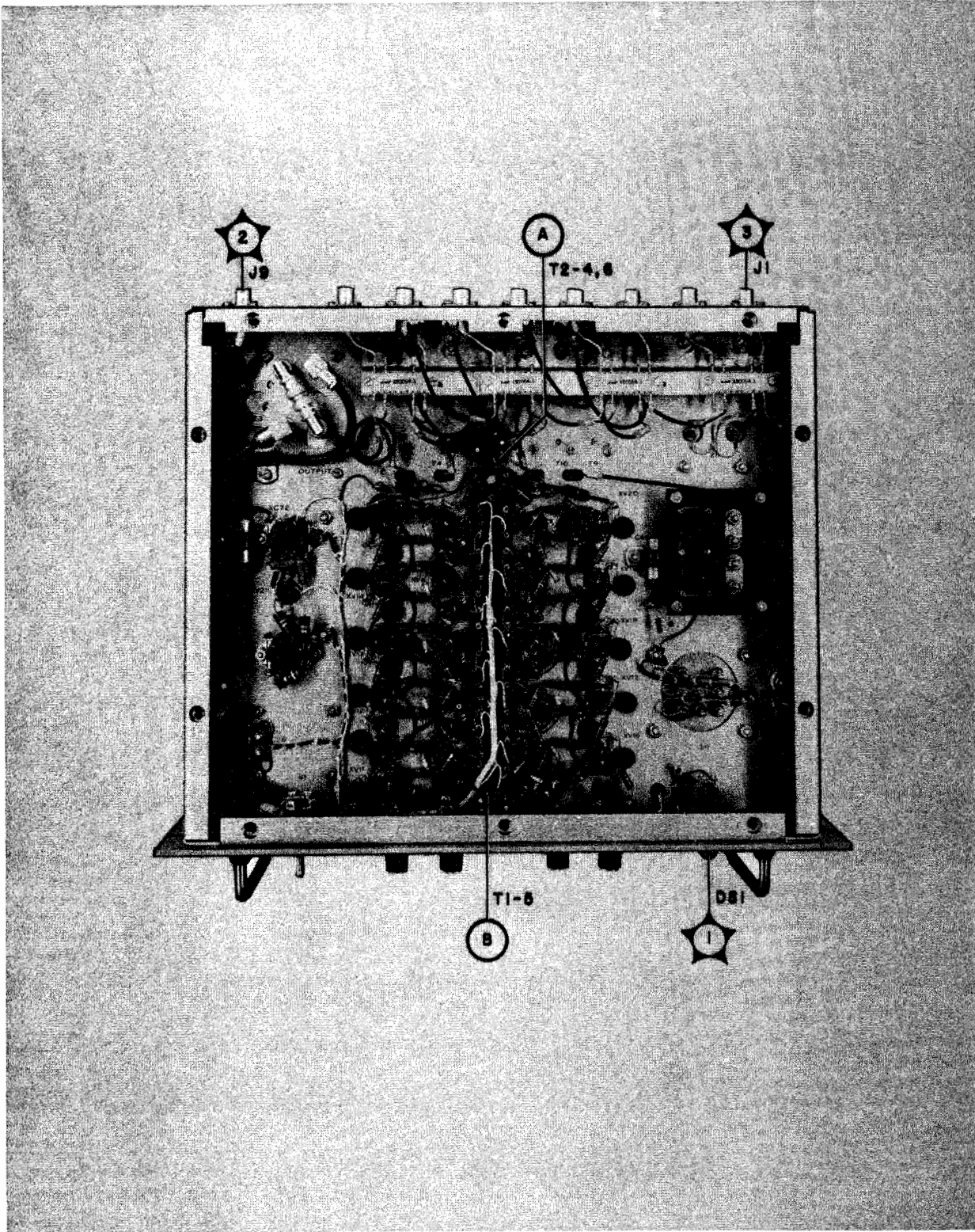

Figure 5-1. Antenna Coupler CU-872/U, Locations of Test Points

TABLE 5-1. ANTENNA COUPLER CU-872/U, TROUBLESHOOTING CHART

STEP	TEST POINT	PRELIMINARY ACTION	NORMAL INDICATION	NEXT STEP
1	①	Place ON-OFF switch (S1) in the ON position.	Red indicator light should be lighted.	If not lighted check lamp (DS1) and fuses (F1, F2) on front panel.
2		Rotate TEST METER SWITCH (S2) through all positions.	TEST METER should indicate 33 ± 3 ma for positions V1-V11 through V10-V20 and 28 ± 3 ma for position B+.	If readings are not normal, check the tubes indicated by TEST METER SWITCH (S2). Refer to table 5-2 for voltage and resistance chart.
3	②	Attach Adapter Connector UG-107B/U to antenna coupler. Connect signal generator and multimeter to adapter. Set frequency on the signal generator set to 32 mc and adjust output voltage of signal generator to read 0.1 volt ac on multimeter.		
4	③	Remove multimeter from Adapter Connector UG-107B/U and connect to OUTPUT NO. 1.	Multimeter should read from 0.106 volt ac to 0.119 volt ac.	If gain is very low check corresponding hybrid transformer.
5		Repeat step 4 for OUTPUT NO. 2 through OUTPUT NO. 8.	Same as step 4.	Same as step 4.
6	Ⓐ	Repeat step 3. Disconnect multimeter from adapter and connect it to measure the rf voltage between pins 4 and 6 of transformer T2 and ground.	Readings on multimeter should be between 0.53 volt ac and 0.595 volt ac.	
7	Ⓑ	Disconnect all test equipment. Connect multimeter to measure the d-c voltage between pin No. 5 of transformer T1 and ground.	Multimeter reading should be +19 volts dc.	High voltage indicates bad voltage regulator tube. Low voltage indicates trouble in the power supply.

TABLE 5-2. ANTENNA COUPLER CU-872/U, VOLTAGE AND RESISTANCE CHART

TUBE SOCKET		TUBE SOCKET PIN NUMBERS								
		1	2	3	4	5	6	7	8	9
XV-1	V	+85	+20	+21	6.3 AC	0	+85	+20	+21	0
	R	∞	57K	780	0	0	∞	57K	780	0
XV-2	V	+85	+20	+21	6.3 AC	0	+85	+20	+21	0
	R	∞	57K	780	0	0	∞	57K	780	0
XV-3	V	+85	+20	+21	6.3 AC	0	+85	+20	+21	0
	R	∞	57K	780	0	0	∞	57K	780	0
XV-4	V	+85	+20	+21	6.3 AC	0	+85	+20	+21	0
	R	∞	57K	720	0	0	∞	57K	720	0
XV-5	V	+85	+20	+21	6.3 AC	0	+85	+20	+21	0
	R	∞	57K	720	0	0	∞	57K	720	0
XV-6	V	+85	+20	+21	6.3 AC	0	+85	+20	+21	0
	R	∞	57K	780	0	0	∞	57K	780	0
XV-7	V	+85	+20	+21	6.3 AC	0	+85	+20	+21	0
	R	∞	57K	780	0	0	∞	57K	780	0
XV-8	V	+85	+20	+21	6.3 AC	0	+85	+20	+21	0
	R	∞	57K	780	0	0	∞	57K	780	0
XV-9	V	+85	+20	+21	6.3 AC	0	+85	+20	+21	0
	R	∞	57K	720	0	0	∞	57K	720	0
XV-10	V	+85	+20	+21	6.3 AC	0	+85	+20	+21	0
	R	∞	57K	720	0	0	∞	57K	720	0
XV-11	V	+180	+65	+85	0	6.3 AC	+180	+65	+85	0
	R	24K	∞	∞	0	0	24K	∞	∞	0
XV-12	V	+180	+65	+85	0	6.3 AC	+180	+65	+85	0
	R	24K	∞	∞	0	0	24K	∞	∞	0
XV-13	V	+180	+65	+85	0	6.3 AC	+180	+65	+85	0
	R	24K	∞	∞	0	0	24K	∞	∞	0
XV-14	V	+180	+65	+85	0	6.3 AC	+180	+65	+85	0
	R	24K	∞	∞	0	0	24K	∞	∞	0
XV-15	V	+180	+65	+85	0	6.3 AC	+180	+65	+85	0
	R	24K	∞	∞	0	0	24K	∞	∞	0
XV-16	V	+180	+65	+85	0	6.3 AC	+180	+65	+85	0
	R	24K	∞	∞	0	0	24K	∞	∞	0
XV-17	V	+180	+65	+85	0	6.3 AC	+180	+65	+85	0
	R	24K	∞	∞	0	0	24K	∞	∞	0
XV-18	V	+180	+65	+85	0	6.3 AC	+180	+65	+85	0
	R	24K	∞	∞	0	0	24K	∞	∞	0

TABLE 5-2. ANTENNA COUPLER CU-872/U, VOLTAGE AND RESISTANCE CHART (Concluded)

TUBE SOCKET		TUBE SOCKET PIN NUMBERS								
		1	2	3	4	5	6	7	8	9
XV-19	V	+180	+65	+85	0	6.3 AC	+180	+65	+85	0
	R	24K	∞	∞	0	0	24K	∞	∞	0
XV-20	V	+180	+65	+85	0	6.3 AC	+180	+65	+85	0
	R	24K	∞	∞	0	0	24K	∞	∞	0
XV-21	V	+105	+0.8	NC	+0.8	+105	+0.8*	+0.8	N/A	N/A
	R	20K	130	∞	130	20K	30K*	130	N/A	N/A

CONDITIONS

1. Voltages measured with no signal input.
2. Resistances measured with all external leads removed.
3. All voltages and resistances measured with Multimeter AN/USM-34 series or equivalent electronic multimeter.

*Before making measurements be sure that TEST METER SWITCH S2 is not in the B+ position. TEST METER M1 will be damaged should the switch be in the B+ position.

TABLE 5-3. ANTENNA COUPLER CU-872/U, TYPICAL TROUBLES

TROUBLE	NATURE OF TROUBLE	SYMPTOMS
Low output at a specific frequency.	Receiver outside pass band of antenna circuits.	Low signal to noise ratio in receiver.
No output from any channel.	Fuse (F1 or F2) defective. Filter capacitor shorted.	Pilot lamp and tubes not lighted.



SECTION 6

REPAIR

6-1. FAILURE REPORT.

Report each failure of the equipment, whether caused by a defective part, wear, improper operation, or an external cause. Use ELECTRONIC FAILURE REPORT form DD787. Each pad of the forms includes full instructions for filling out the forms and forwarding them to the Bureau of Ships. However, the importance of providing complete information cannot be emphasized too much. Be sure that you include the model designation and serial number of the equipment (from the equipment identification plate), and the type number and reference designation of the particular defective part (from the technical manual). Describe the cause of the failure completely, continuing on the back of the form if necessary. Do not substitute brevity for clarity. And remember—there are two sides to the failure report—

YOUR SIDE

BUREAU SIDE

Every FAILURE REPORT is a boost for you:

The Bureau of Ships used the information to:

1. It shows that you are doing your job.
2. It helps make your job easier.
3. It insures available replacements.
4. It gives you a chance to pass your knowledge

1. Evaluate present equipment.
2. Improve future equipment.
3. Order replacements for stock.
4. Prepare field changes

to every man on the team.

5. Publish maintenance data.

Always keep a supply of failure report forms on board. You can get them from the nearest District Publications and Printing Office.

6-2. OUTPUT ISOLATION MEASUREMENT.

a. GENERAL.—The following paragraph gives a detailed procedure for determining the output isolation of Antenna Coupler CU-872/U.

b. TEST EQUIPMENT AND SPECIAL TOOLS.—Test equipment required for adjustment of Antenna Coupler CU-872/U consists of the following:

1. R-F Signal Generator, Hewlett-Packard 606A, or equivalent.
2. Radio Interference Measuring Set AN/URM-47 series, or equivalent.

c. SPECIAL JIGS.—Two 20 \pm 5%-ohm resistors, two type N UG-58A/U connectors and two type BNC UG-1094/U connectors are required to fabricate two 20-ohm pads required for measurements of isolation. Make the pads as follows:

Step 1. Using a short length of coaxial cable, connect one 20-ohm resistor between the two UG-58A/U connectors. Solder a jumper wire between cable shields on each side of the resistors.

Step 2. Using a short length of coaxial cable, connect one 20-ohm resistor between the two type UG-1094/U connectors. Solder a jumper wire between cable shields on each side of the resistor.

d. CONTROL SETTINGS.—Place the ON-OFF switch in the ON position and allow a 10-minute warm-up period.

e. PROCEDURE.—The determination of the output isolation for Antenna Coupler CU-872/U is given in the following step-by-step procedure.

Step 1. Set the Hewlett-Packard 606A r-f signal generator or equivalent for any frequency between 20 and 32 mc.

Step 2. Connect the output Hewlett-Packard 606A r-f signal generator to the input of Radio Interference Measuring Set AN/URM-47, through two series connected 20-ohm pads.

Step 3. Adjust the output level of the Hewlett-Packard 606A r-f signal generator for approximately a mid-scale indication on Radio Interference Measuring Set AN/URM-47 series or equivalent. Record this indication for use as a 0-db reference.

Step 4. Without changing the output level of the Hewlett-Packard 606A r-f signal generators or equivalent, connect its output to OUTPUTS jack J1, on the antenna coupler, through a 20-ohm pad.

Step 5. Connect Radio Interference Measuring Set AN/URM-47 series or equivalent to OUTPUTS jack J2 on the antenna coupler through a 20-ohm pad. The indication on the radio interference measuring set should be at least 40-db less than the 0-db reference recorded in step 3.

Step 6. In turn, connect Radio Interference Measuring Set AN/URM-47 series or equivalent, through a 20-ohm resistor to OUTPUTS jacks J3 through J8. In each case the indication on the radar interference measuring set should be at least 40-db less than the 0-db reference recorded in step 3.

6-3. ADJUSTMENT OF COILS L49 THROUGH L52.

a. GENERAL.—Coils L49 through L52 should need adjustment only in case of damage. If the coil has not been broken replacement may not be necessary and reference should be made to paragraph 6-3d. If the coil has been broken, replacement and adjustment will be necessary. Location of the coils is shown in figure 6-1.

b. TEST EQUIPMENT AND SPECIAL TOOLS.—Test equipment required for a coil adjustment is the same as that given in paragraph 6-2b.

c. SPECIAL JIGS.—Two 20-ohm pads should be fabricated as described in paragraph 6-2c.

d. COIL REPLACEMENT.

Step 1. Remove damaged coil. It is possible that the coil does not contain any turns but many simply consist of a straight section of wire. Inspect the damaged coil to determine the number of turns needed in the replacement coil.

Step 2. Make a new coil using number 18 wire. Wind on a 3/16-inch diameter form. Coil will contain from zero to three turns depending upon the number of turns in the removed coil.

Step 3. Install new coil.

e. COIL ADJUSTMENT.

Step 1. Adjust the Hewlett-Packard 606A r-f signal generator, or equivalent, to give a frequency of 32 megacycles.

Step 2. Connect Radio Interference Measuring Set AN/URM-47 series, or equivalent, to the output of the r-f signal generator through two series-connected 20-ohm pads. Adjust the Hewlett-Packard 606A r-f signal generator level to give approximately a mid-scale deflection on the radio interference measuring set. Record the indication of the radio interference measuring set for use as a 0-db reference. Do not change the output level of the r-f signal generator during the remainder of the adjustment.

Step 3. Locate the coil to be adjusted in the following table. The Hewlett-Packard 606A r-f signal generator, or equivalent, and Radio Interference Measuring Set AN/URM-47 series, or equivalent, are to be connected through a 20-ohm pad to the terminals indicated for the specific coil.

COIL	CONNECT SIGNAL GENERATOR TO OUTPUT	CONNECT RADIO TEST SET TO OUTPUT
L51	1	2
L52	3	4
L49	5	6
L50	7	8

Step 4. Close or open the coil turns as required to obtain minimum indication on the Radio Interference Measuring Set AN/URM-47 series, or equivalent. When the coil is properly adjusted the radio interference measuring set should indicate a signal level 45 db below that obtained in step 2. No noticeable increase in performance will be obtained at an isolation level greater than 50 db. If it is impossible to obtain an isolation of 45 db by opening or closing the coil turns, increase or decrease the number of turns and repeat this step. If closing the coil does not have sufficient effect, it may be necessary to connect the balance resistor (R96, R99, R104, R107) directly between transformers, thereby bypassing the coil.

6-4. ADJUSTMENT OF AMPLITUDE RESPONSE OF FILTER Z2.

a. GENERAL.—The following paragraph gives a detailed procedure for adjustment of filter Z2. Locations of adjustments are shown in figure 6-1. All adjustments on filter Z2 are sealed with cement. Adjustment should be made only after a critical component fails and is replaced, or when other circumstances require it. Whenever the amplitude response of filter Z2 is adjusted, the adjustments described in paragraph 6-5 must also be performed.

b. TEST EQUIPMENT AND SPECIAL TOOLS.—Test equipment required for adjustment of filter Z2 consists of the following:

1. R-F Signal Generator, Hewlett-Packard 606A, or equivalent.
2. Interference Measuring Set AN/URM-47 series, or equivalent.
3. Radio Test Set AN/PRM-1 series, or equivalent.

c. SPECIAL JIGS.—Two 20-ohm pads should be fabricated as described in paragraph 6-2c.

d. PROCEDURE.—Adjust the filter as follows:

Step 1. Turn the adjustment screws of capacitors C204 and C206 to their maximum shaft extension.

Step 2. Set the Hewlett-Packard 606A r-f signal generator or equivalent for an output frequency of 58 mc.

Step 3. Connect the output of the Hewlett-Packard 606A r-f signal generator or equivalent through two series connected 20-ohm pads to the input of Radio Interference Measuring Set AN/URM-47 series or equivalent.

Step 4. Adjust the output signal level of the Hewlett-Packard 606A r-f signal generator or equivalent to obtain an indication greater than 0.3 volts ac on Radio Interference Measuring Set AN/URM-47 series or equivalent. Record the meter indication for use as a 0-db reference.

Step 5. Without changing the output level of the Hewlett-Packard 606A r-f signal generator or equivalent, connect the output through a 20-ohm pad to connector J201 on filter Z2.

Step 6. Connect Radio Interference Measuring Set AN/URM-47 series or equivalent through a 20-ohm pad to connector J202 on filter Z2.

Step 7. Adjust capacitors C202 and C208 to obtain a minimum indication on Radio Interference Measuring Set AN/URM-47 series or equivalent. This indication should be more than 50 db below the reference level recorded in step 4.

Step 8. Set the Hewlett-Packard 606A r-f signal generator or equivalent for an output frequency of 54 mc. Repeat the procedures of steps 3 through 6. The indication obtained in step 6 should be more than 30 db below the reference level recorded in step 4.

Step 9. Set the Hewlett-Packard 606A r-f signal generator or equivalent for an output frequency of 1.3 mc.

Step 10. Connect the output of the Hewlett-Packard 606A r-f signal generator or equivalent through two series connected 20-ohm pads to Radio Test Set AN/PRM-1 series or equivalent.

Step 11. Adjust the r-f output level of the Hewlett-Packard 606A r-f signal generator or equivalent to obtain an indication greater than 0.3 volts on Radio Test Set AN/PRM-1 series or equivalent. Record this indication for use as a 0-db reference.

Step 12. Without changing the output level of the Hewlett-Packard 606A r-f signal generator or equivalent, connect its output to connector J203 on filter Z2 through a 20-ohm pad.

Step 13. Connect Radio Test Set AN/PRM-1 series or equivalent to connector J204 on filter Z2 through a 20-ohm pad.

Step 14. Adjust inductors L206 and L209 to obtain a minimum indication on Radio Test Set AN/PRM-1 series or equivalent. This indication should be more than 50 db below the reference level recorded in step 11.

Step 15. Set the Hewlett-Packard 606A r-f signal generator or equivalent for an output frequency of 1.5 mc. Repeat the procedures of steps 10 through 13. The indication obtained in step 13 should be at least 30 db below the reference recorded in step 11.

Step 16. Connect connector J202 to J203 on filter Z2.

Step 17. Set the Hewlett-Packard 606A r-f signal generator for an output frequency of 32 mc.

Step 18. Connect the output of the Hewlett-Packard 606A r-f signal generator or equivalent through two series-connected 20-ohm pads to the input of Radio Interference Measuring Set AN/URM-47 series or equivalent.

Step 19. Adjust the output signal level of the Hewlett-Packard 606A r-f signal level of the Hewlett-Packard 606A r-f signal generator, or equivalent, to obtain an indication greater than 0.3 volts on Radio Interference Measuring Set AN/URM-47 series, or equivalent. Record this indication for use as a 0-db reference.

Step 20. Without changing the output level of the Hewlett-Packard 606A r-f signal generator, or equivalent, connect its output to connector J201 on filter Z2 through a 20-ohm pad.

Step 21. Connect Radio Interference Measuring Set AN/URM-47 series or equivalent through a 20-ohm pad to connector J204 on filter Z2. The indication obtained on the radio interference measuring set should be less than 0.6 db below the reference recorded in step 19.

Step 22. Set the Hewlett-Packard 606A r-f signal generator for an output frequency of 20 mc.

Step 23. Repeat steps 18 through 21.

Step 24. Set the Hewlett-Packard 606A r-f signal generator for an output frequency of 2 mc.

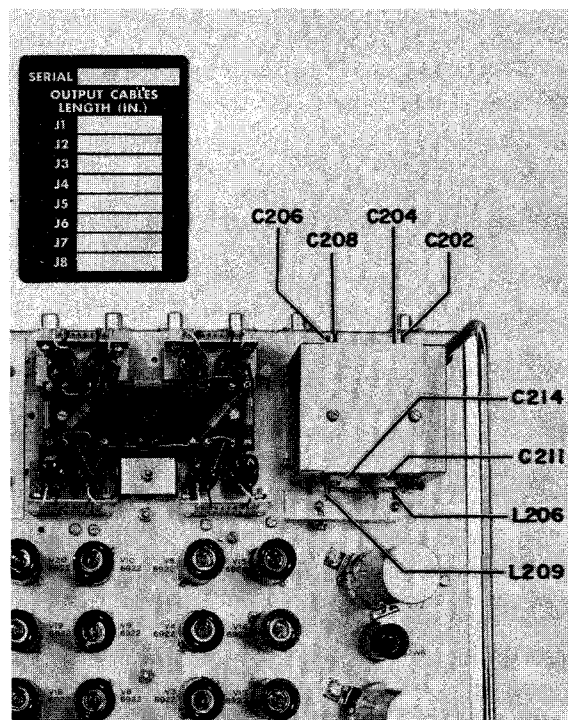

Figure 6-1. Antenna Coupler CU-872/U,
 Location of Adjustments

Step 25. Connect the output of the Hewlett-Packard 606A r-f signal generator or equivalent through two series-connected 20-ohm pads to Radio Test Set AN/PRM-1 series or equivalent.

Step 26. Adjust the r-f output level of the Hewlett-Packard 606A r-f signal generator or equivalent to obtain an indication greater than 0.3 volts on Radio Test Set AN/PRM-1 series or equivalent. Record this indication for use as 0-db reference.

Step 27. Without changing the output level of the Hewlett-Packard 606A r-f signal generator or equivalent, connect its output to connector J201 on filter Z2 through a 20-ohm pad.

Step 28. Connect Radio Test Set AN/PRM-1 series or equivalent through a 20-ohm pad to connector J204 on filter Z2. The indication obtained on the radio test set should be less than 1.5 db below the reference recorded in step 26.

Step 29. Set the Hewlett-Packard 606A r-f signal generator for an output frequency of 8 mc.

Step 30. Repeat the procedure of step 25 through step 28. The indication obtained in step 28 should be less than 0.5 db below the indication recorded in step 26.

6-5. PHASE ADJUSTMENT.

a. GENERAL - The following paragraph gives a detailed adjustment procedure for setting the output signals of one antenna coupler in phase with the output signal of the reference output of a typical reference antenna coupler. Any antenna coupler produced under a given contract may be selected as a typical reference coupler and the no. 3 output used as a reference for alignment of units where repair is necessary and the phase alignment then exceeds the specified limits. The basis for this type of reference selection is the fact that all units on a given contract have their no. 3 outputs aligned to be almost exactly in phase at 28 and 2.5 mc, which are the basic phase alignment frequencies.

Locations of phase adjustments are shown in figure 6-1. All adjustments on filter Z2 are sealed with cement and phase adjustment should be made only after a critical component fails and the phase of the no. 3 output of the unit is found to be more than 2 degrees at 28 mc when compared to the no. 3 output a chosen reference coupler. The phase adjustment procedure of this section may be performed independently of the adjustment of amplitude response of filter Z2 described in paragraph 6-4.

b. TEST EQUIPMENT AND SPECIAL TOOLS. - Test equipment required for phase adjustment of Antenna Coupler CU-872/U consists of the following:

1. R-F Signal Generator, Hewlett-Packard 606A or equivalent.
2. Phase Meter, Advanced Electronics Lab Inc. Type 202 Vectorlizer with 75 ohm loads used on the high-frequency probe.

c. SPECIAL JIGS. - An input amplitude compensation is required to provide input signals of equal amplitude to the antenna couplers. Three BNC connectors, UG-1094/U, two 100-ohm resistors,

RN70B101, and one potentiometer, RV6LAYS101A, are required. To fabricate the amplitude compensator, proceed as follows:

Step 1. Mount the RV6LAYS101A potentiometer and around its circumference mount the three UG-1094/U connectors.

Step 2. Connect the input connector to the wiper arm of the potentiometer.

Step 3. Connect one of the output connectors to the high end of the potentiometer and the other output connector to the low end of the potentiometer.

Step 4. Connect a 100-ohm resistor between the wiper arm of the potentiometer and one of the output connectors.

Step 5. Connect a 100-ohm resistor between the wiper arm of the potentiometer and the other output connector.

d. PROCEDURE. - Adjust the phase of the antenna coupler output signals as follows:

Step 1. Set the Hewlett-Packard 606A r-f signal generator for an output frequency of 28 mc and the output level to approximately 1 volt.

Step 2. Connect the output of the Hewlett-Packard 606A r-f signal generator to the input connector of the amplitude compensator described in paragraph 6-5c.

Step 3. Connect one output connector on the amplitude compensator to ANTENNA INPUT connector J9 on the standard reference antenna coupler using a length of coaxial cable.

Step 4. Connect the other output connector on the amplitude compensator to ANTENNA INPUT connector J9 on the antenna coupler to be adjusted using a length of coaxial cable which is the same length as used in step 3 $\pm 1/16$ inch.

Step 5. Connect one input of the Type 202 Vectorlizer h-f probe to the OUTPUT 3 connector J3 on the standard reference coupler and the other input to the OUTPUT 3 connector J3 on the antenna coupler to be adjusted. For this connection use coaxial cables which are of the same length $\pm 1/16$ inch.

Step 6. Set the Type 202 Vectorlizer for maximum sensitivity.

Step 7. Adjust the input level compensator for a minimum reading on the Type 202 Vectorlizer.

Step 8. Disconnect one input to the Type 202 Vectorlizer and set the output level of the Hewlett-Packard 606A r-f signal generator to obtain an indication of 1.0 volt on the Type 202 Vectorlizer.

Step 9. Reconnect the cable disconnected in step 8 and observe the indication on the Type 202 Vectorlizer.

Step 10. Adjust capacitors C204 and C206 on filter Z2 of the antenna coupler to obtain a zero or near zero indication on the Type 202 Vectorlizer.

Step 11. The indication should be less than 0.005 volts. If the indication is not less than 0.005 volts repeat steps 7 to 10.

Step 12. Set the Hewlett-Packard 606A r-f signal generator for an output frequency of 2.5 mc and the output level to approximately 1.0 volt.

Step 13. Repeat steps 2 through 11 of this procedure except in step 10 adjust capacitors C211 and C214.

Step 14. Set the Hewlett-Packard 606A r-f signal generator for an output frequency of 8 mc and an output signal level of 1.0 volt.

Step 15. Repeat steps 2 through 9. The indication in step 9 should be less than 0.035 volts.

Step 16. Set the Hewlett-Packard 606A r-f signal generator for an output frequency of 16 mc and an output signal level of 1.0 volt.

Step 17. Repeat steps 2 through 9. The indication in step 9 should be less than 0.035 volts.

Step 18. Set the Hewlett-Packard 606A r-f signal generator for an output frequency of 28 mc and an output signal level of 1.0 volts.

Step 19. Repeat steps 2 through 9. The indication in step 9 should not be less than 0.035 volts.

Step 20. To phase check OUTPUTS 1, 2, 4, 5, 6, 7, and 8 of the unit that has been adjusted repeat steps 1 through 9, 12 and 2 through 9, and 14 through 19 using each of the above outputs in place of the adjusted coupler output 3 in step 5. The indications of step 9 should be less than 0.035 volts.

Step 21. After phase alignment has been accomplished, reapply cement to C204, C206, C211 and C214 on Z2.

6-6. OUTPUT PHASING CABLE REPLACEMENT

a. GENERAL. - The lengths of RG-188/U coaxial cable that connect the hybrid transformer taper pin blocks are used to give small amounts of phase adjustment to the individual outputs of the antenna coupler. (See figure 5-1.) These cables will need to be changed only if damaged and will not require changes even though the antenna coupler must be aligned as described in section 6-5.

b. PROCEDURE. - Replace the output phasing cables as follows:

Step 1. Extract the damaged cable from the terminating taper pin blocks, AMP Type 480064-3.

Step 2. Consult the output cable length identification plate located inside the chassis near the output terminals of Z1 and note the length given for the cable to be replaced. The output cable identification plate is shown at the top of figure 6-1.

Step 3. Make new cable as shown in figure 6-2. Use length found in step 2 as the dimension L.

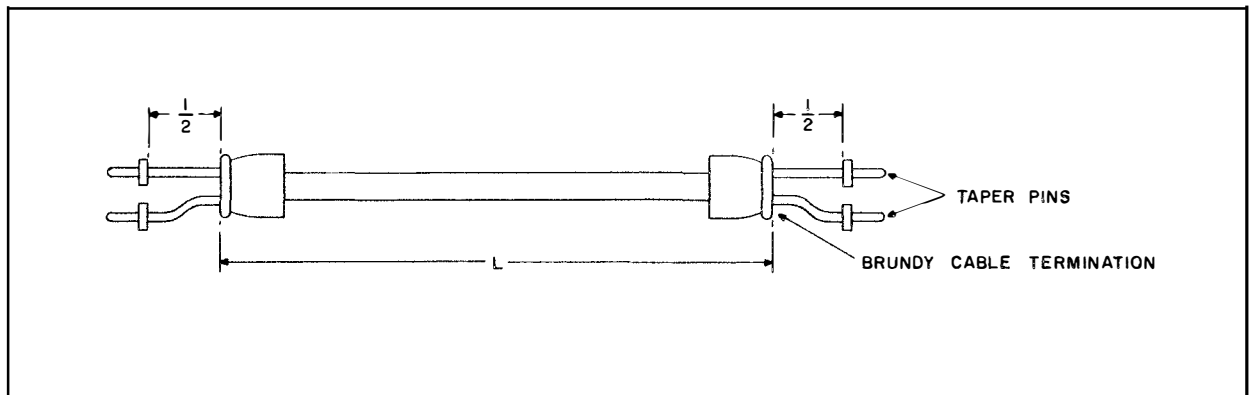

Figure 6-2. Antenna Coupler CU-872/U, Typical Cable Assembly

Paragraph
6-6b

NAVSHIPS 93803(A)

CU-872/U
REPAIR

Step 4. Firmly insert the new cable into proper taper pin terminals and lace to prevent interference with amplifier and bottom cover.

Step 5. Check the phase of the output associated with the replaced cable by the method of paragraph 6-5.

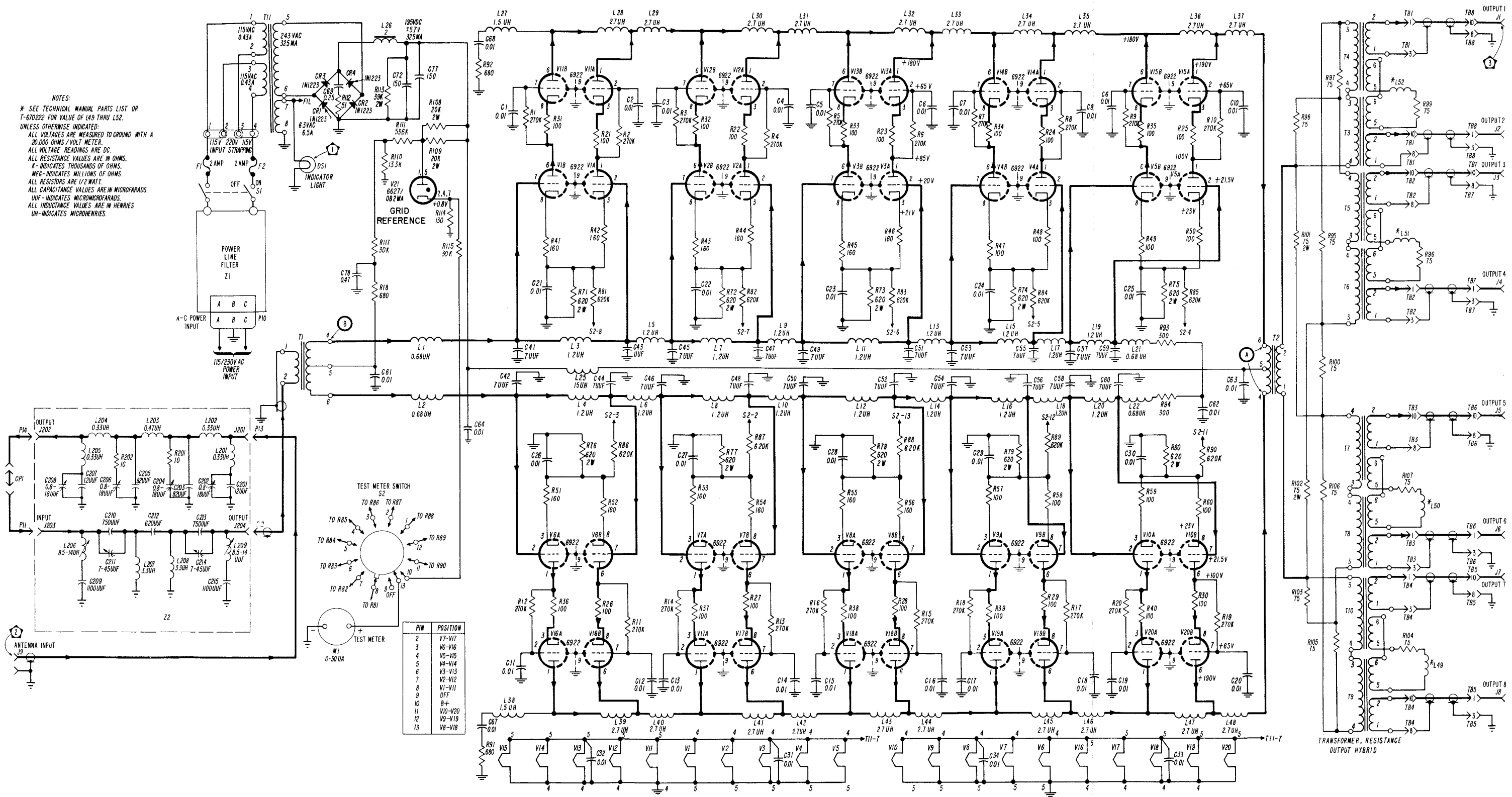

Figure 6-3. Antenna Coupler CU-872/U, Schematic Diagram

ORIGINAL

SECTION 7

PARTS LIST

7-1. INTRODUCTION.

Reference designations have been assigned to identify all maintenance parts of the equipment. They are used for marking the equipment and are included on drawings, diagrams and the parts list. The letters of the designation indicate the kind of part (generic group) such as resistor, capacitor, electron tube, etc. The number differentiates between parts of the same generic group. Sockets associated with a particular plug-in device, such as an electron tube, are identified by a reference designation, which includes the reference designation of the plug-in device. For example, the socket for tube V001 is designated XV001.

7-2. MAINTENANCE PARTS LIST.

Table 7-1 lists all component parts. Column 1 lists the reference series of the various parts in alphabetical and numerical order. Column 2 gives the names and describes the various parts. Complete information is given for all key parts (parts differing from any part previously listed in this table). Column 3 indicates how the part is used and gives its functional location in the unit.

7-3. STOCK NUMBER IDENTIFICATION.

New Stock Number Identification Tables (SNIT's) issued by the Electronics Supply Office include Federal Stock Numbers and Source, Maintenance and Recoverability Codes. Therefore, reference shall be made to the SNIT for this information.

7-4. LIST OF MANUFACTURERS.

Table 7-2 lists the manufacturers of parts used in this equipment.

TABLE 7-1. ANTENNA COUPLER CU-872/U, MAINTENANCE PARTS LIST

REF DESIG	NOTES	NAME AND DESCRIPTION	FUNCTION
1-99 SERIES		ANTENNA COUPLER PROVIDES COUPLING BETWEEN A SINGLE ANTENNA AND EIGHT RECEIVERS, 2-32MC, 115/230VAC, 48 TO 62 CPS, SINGLE PHASE, FEATURES PHASE CONTROL BETWEEN ALL OUTPUTS WITHIN PLUS OR MINUS 2 DEG. OVER THEIR OPERATING RANGE, GRAY ENAMEL CASE, 19 IN LG, 16-1/2 IN. WIDE, 7 IN HIGH, STANDARD RACK MOUNTING, MFR 89661, DWG 490D502G01 NAVY TYPE CU872/U.	
C 001		CAPACITOR, FIXED, CERAMIC DIELECTRIC 10,000 UUF PLUS 100% -20%, 500 V DC WORKING, MFR 89661, PART NO. 54B7069H06	V11A RF BY-PASS
C 002		SAME AS C1	V11B RF BY-PASS
C 003		SAME AS C1	V12A RF BY-PASS
C 004		SAME AS C1	V12B RF BY-PASS
C 005		SAME AS C1	V13A RF BY-PASS
C 006		SAME AS C1	V13B RF BY-PASS
C 007		SAME AS C1	V14A RF BY-PASS
C 008		SAME AS C1	V14B RF BY-PASS
C 009		SAME AS C1	V15A RF BY-PASS
C 010		SAME AS C1	V15B RF BY-PASS
C 011		SAME AS C1	V16A RF BY-PASS
C 012		SAME AS C1	V16B RF BY-PASS
C 013		SAME AS C1	V17A RF BY-PASS
C 014		SAME AS C1	V17B RF BY-PASS
C 015		SAME AS C1	V18A RF BY-PASS
C 016		SAME AS C1	V18B RF BY-PASS
C 017		SAME AS C1	V19A RF BY-PASS
C 018		SAME AS C1	V19B RF BY-PASS
C 019		SAME AS C1	V20A RF BY-PASS
C 020		SAME AS C1	V20B RF BY-PASS
C 021		SAME AS C1	V1 CATHODE BY-PASS
C 022		SAME AS C1	V2 CATHODE BY-PASS
C 023		SAME AS C1	V3 CATHODE BY-PASS
C 024		SAME AS C1	V4 CATHODE BY-PASS
C 025		SAME AS C1	V5 CATHODE BY-PASS
C 026		SAME AS C1	V6 CATHODE BY-PASS
C 027		SAME AS C1	V7 CATHODE BY-PASS
C 028		SAME AS C1	V8 CATHODE BY-PASS

CU-872/U
PARTS LIST

NAVSHIPS 93803(A)

TABLE
7-1

TABLE 7-1. ANTENNA COUPLER CU-872/U, MAINTENANCE PARTS LIST (CONT.)

REF DESIG	NOTES	NAME AND DESCRIPTION	FUNCTION
C 029	SAME AS C1		V9 CATHODE BY-PASS
C 030	SAME AS C1		V10 CATHODE BY-PASS
C 031	SAME AS C1		V3 FILAMENT BY-PASS
C 032	SAME AS C1		V13 FILAMENT BY-PASS
C 033	SAME AS C1		V18 FILAMENT BY-PASS
C 034	SAME AS C1		V8 FILAMENT BY-PASS
C 035 THRU	NOT USED		
C 040 C 041	CAPACITOR, FIXED, CERAMIC DIELECTRIC 7 UUF ±0.25 UUF, 500 V DC WORKING, CC20CH070C, SPEC MIL-C-20		GRID LINE CAPACITANCE
C 042	SAME AS C41		GRID LINE CAPACITANCE
C 043	SAME AS C41		GRID LINE CAPACITANCE
C 044	SAME AS C41		GRID LINE CAPACITANCE
C 045	SAME AS C41		GRID LINE CAPACITANCE
C 046	SAME AS C41		GRID LINE CAPACITANCE
C 047	SAME AS C41		GRID LINE CAPACITANCE
C 048	SAME AS C41		GRID LINE CAPACITANCE
C 049	SAME AS C41		GRID LINE CAPACITANCE
C 050	SAME AS C41		GRID LINE CAPACITANCE
C 051	SAME AS C41		GRID LINE CAPACITANCE
C 052	SAME AS C41		GRID LINE CAPACITANCE
C 053	SAME AS C41		GRID LINE CAPACITANCE
C 054	SAME AS C41		GRID LINE CAPACITANCE
C 055	SAME AS C41		GRID LINE CAPACITANCE
C 056	SAME AS C41		GRID LINE CAPACITANCE
C 057	SAME AS C41		GRID LINE

ORIGINAL

7-3

TABLE
7-1

NAVSHIPS 93803(A)

CU-872/U
PARTS LIST

TABLE 7-1. ANTENNA COUPLER CU-872/U, MAINTENANCE PARTS LIST (CONT.)

REF DESIG	NOTES	NAME AND DESCRIPTION	FUNCTION
C 058	SAME AS C41		CAPACITANCE GRID LINE
C 059	SAME AS C41		CAPACITANCE GRID LINE
C 060	SAME AS C41		CAPACITANCE GRID LINE
C 061	SAME AS C1		CAPACITANCE T1 SECONDARY
C 062	SAME AS C1		RF BY-PASS GRID LINE
C 063	SAME AS C1		DC BLOCKING T2 PRIMARY
C 064	SAME AS C1		RF BY-PASS B PLUS BY-PASS
C 065	NOT USED		
C 066	NOT USED		
C 067	SAME AS C1		PLATE LINE DC BLOCKING
C 068	SAME AS C1		PLATE LINE DC BLOCKING
C 069	CAPACITOR, FIXED, PAPER DIELECTRIC 220,000 UUF ±20%, 400 V DC WORKING, CH04A1ME224M, SPEC MIL-C-18312		B PLUS SPIKE SUPPRESSOR
C 070	NOT USED		
C 071	NOT USED		
C 072	CAPACITOR, FIXED, ELECTROLYTIC 150 UF, 300 V DC WORKING, CE51F151N SPEC MIL-C-62		B PLUS FILTER
C 073 THRU	NOT USED		
C 076			
C 077	SAME AS C72		B PLUS FILTER
C 078	CAPACITOR, FIXED, PAPER DIELECTRIC 470,000 UUF ±20%, 100 V DC WORKING, CP05A1EB474M, SPEC MIL-C-25		BIAS FILTERING
C 079 THRU	NOT USED		
C 099			
CP 001	ADAPTER, CONNECTOR MALE TO MALE, 50 OHMS, 500 V PEAK, UG491A/U, MS35176.		CONNECTOR ADAPTER
CP 002 THRU	NOT USED		
CP 099			
CR 001	SEMICONDUCTOR DEVICE, DIODE SILICON, AXIAL WIRE LEADS, 1N540, SPEC MIL-E-1C		B PLUS RECTIFIER MOUNTING
CR 002	SAME AS CR1		B PLUS RECTIFIER
CR 003	SAME AS CR1		B PLUS RECTIFIER
CR 004	SAME AS CR1		B PLUS RECTIFIER

CU-872/U
PARTS LIST

NAVSHIPS 93803(A)

TABLE
7-1

TABLE 7-1. ANTENNA COUPLER CU-872/U, MAINTENANCE PARTS LIST (Cont.)

REF DESIG	NOTES	NAME AND DESCRIPTION	FUNCTION
CR 005 THRU CR 099	NOT USED		
DS 001		LAMP, INCANDESCENT 0.15 AMP, 6-8 VOLT, T-3 1/4 BULB, MS15571-2	PILOT LIGHT
DS 002 THRU DS 099	NOT USED		
E 001		TERMINAL BOARD 6 TERMINALS, PHENOLIC, 3.5 IN. LG, 2.875 IN. W, 0.125 IN. THK, MFR 89661, PART NO 230B973G01	B PLUS RECTIFIER MOUNTING
E 002		TERMINAL BOARD PHENOLIC, 5.25 IN. LG, 1.75 IN. W, 0.125 IN. THK, MFR 89661, PART NO. 230B972G01	COMPONENT MOUNTING
E 003		TERMINAL BOARD 31 TERMINALS, PHENOLIC, MFR 89661, PART NO. 341C132G01.	COMPONENT MOUNTING
E 004		INSULATOR, STANDOFF MELAMINE INSULATION, 9/16 IN. LG, 1/4 IN. ACID FLATS, MFR 81312, PART NO. 776	TIE POINT
E 005		SAME AS E4	TIE POINT
E 006		SAME AS E4	TIE POINT
E 007		SAME AS E4	TIE POINT
E 008		SAME AS E4	TIE POINT
E 009		SAME AS E4	TIE POINT
E 010		SAME AS E4	TIE POINT
E 011		SAME AS E4	TIE POINT
E 012		SAME AS E4	TIE POINT
E 013		SAME AS E4	TIE POINT
E 014		SAME AS E4	TIE POINT
E 015		KNOB ROUND W/DIAL SKIRT, 1.822 MAX. DIA, 1/4 IN. DIA SHAFT, MATTE FINISH, MFR 49956, PART NO. 125-3-2G	TEST METER SWITCH
E 016		SHIELD, ELECTRON TUBE 2.125 IN. H, 0.810 IN. DIA, BLACK WRINKLE FINISH S0765, SPEC MIL-S-19785	TUBE SHIELD
E 017		RETAINER, ELECTRON TUBE 1.375 DIA OPEN 1.125 IN. W, MFR 07387, PART NO. 926C-81	TUBE CLAMP
E 018		SAME AS E17	TUBE CLAMP
E 019		SHIELD, ELECTRON TUBE HEAT DISSIPATING, W/SHIELD AND BASE INSERT, 9 PIN STYLE, MFR 13499 PART NO. 66J-5	TUBE SHIELD INSERT
E 020 THRU E 099	NOT USED		
F 001		FUSE, CARTRIDGE 2 AMP, 125 V MAX.	POWER INPUT

ORIGINAL

7-5

TABLE
7-1

NAVSHIPS 93803(A)

CU-872/U
PARTS LIST

TABLE 7-1. ANTENNA COUPLER CU-872/U, MAINTENANCE PARTS LIST (CONT.)

REF DESIG	NOTES	NAME AND DESCRIPTION	FUNCTION
		TIME LAG, F02D2R00B, MIL-F-15160C	
F 002		SAME AS F1	POWER INPUT
F 003		SAME AS F1	SPARE
F 004		SAME AS F1	SPARE
F 005			
THRU		NOT USED	
F 099			
J 001		CONNECTOR, RECEPTACLE, ELECTRICAL 1 CONTACT COAXIAL TYPE, UG58A/U	RF OUTPUT
J 002		SAME AS J1	RF OUTPUT
J 003		SAME AS J1	RF OUTPUT
J 004		SAME AS J1	RF OUTPUT
J 005		SAME AS J1	RF OUTPUT
J 006		SAME AS J1	RF OUTPUT
J 007		SAME AS J1	RF OUTPUT
J 008		SAME AS J1	RF OUTPUT
J 009		SAME AS J1	RF INPUT
J 010		PART OF Z1. LISTED FOR REFERENCE ONLY	
J 011			
THRU		NOT USED	
J 014			
J 015		SAME AS J1	
J 016			
THRU		NOT USED	
J 099			
L 001		COIL, RADIO FREQUENCY 0.68 UH ±5%, 0.10 OHMS, AT 1/2 W, PHENOLIC CORE, MFR 82142, PART NO. 10200-22	GRID LINE
L 002		SAME AS L1	GRID LINE
L 003		COIL, RADIO FREQUENCY 1.2 UH ±5, MFR 89661, PART NO. 548M108H48	GRID LINE
L 004		SAME AS L3	GRID LINE
L 005		SAME AS L3	GRID LINE
L 006		SAME AS L3	GRID LINE
L 007		SAME AS L3	GRID LINE
L 008		SAME AS L3	GRID LINE
L 009		SAME AS L3	GRID LINE
L 010		SAME AS L3	GRID LINE
L 011		SAME AS L3	GRID LINE
L 012		SAME AS L3	GRID LINE
L 013		SAME AS L3	GRID LINE
L 014		SAME AS L3	GRID LINE
L 015		SAME AS L3	GRID LINE
L 016		SAME AS L3	GRID LINE
L 017		SAME AS L3	GRID LINE
L 018		SAME AS L3	GRID LINE
L 019		SAME AS L3	GRID LINE
L 020		SAME AS L3	GRID LINE
L 021		SAME AS L1	GRID LINE

CU-872/U
PARTS LIST

NAVSHIPS 93803(A)

TABLE
7-1

TABLE 7-1. ANTENNA COUPLER CU-872/U, MAINTENANCE PARTS LIST (CONT.)

REF DESIG	NOTES	NAME AND DESCRIPTION	FUNCTION
L 022	SAME AS L1		GRID LINE
L 023	NOT USED		
L 024	NOT USED		
L 025	COIL, RADIO FREQUENCY 15 UH ±10%, Q OF 40 AT 3 MC, LT8K007, SPEC MIL-C-15305A		B PLUS RF DECOUPLING
L 026	REACTOR 2 H AT 325 MA DC, 50 OHMS, MFR 96175, PART NO. 31741		SMOOTHING CHOKE
L 027	COIL, RADIO FREQUENCY 1.5 UH ±5%, 1300 MA MAX DC CURRENT, 1/2 W, MFR 82142, PART NO. 10200-26		PLATE LINE
L 028	COIL, RADIO FREQUENCY 2.7 UH, ±5%, 840 MA MAX DC CURRENT, MFR 82142, PART NO. 10200-30		PLATE LINE
L 029	SAME AS L28		PLATE LINE
L 030	SAME AS L28		PLATE LINE
L 031	SAME AS L28		PLATE LINE
L 032	SAME AS L28		PLATE LINE
L 033	SAME AS L28		PLATE LINE
L 034	SAME AS L28		PLATE LINE
L 035	SAME AS L28		PLATE LINE
L 036	SAME AS L28		PLATE LINE
L 037	SAME AS L28		PLATE LINE
L 038	SAME AS L27		PLATE LINE
L 039	SAME AS L28		PLATE LINE
L 040	SAME AS L28		PLATE LINE
L 041	SAME AS L28		PLATE LINE
L 042	SAME AS L28		PLATE LINE
L 043	SAME AS L28		PLATE LINE
L 044	SAME AS L28		PLATE LINE
L 045	SAME AS L28		PLATE LINE
L 046	SAME AS L28		PLATE LINE
L 047	SAME AS L28		PLATE LINE
L 048	SAME AS L28		PLATE LINE
L 049			
THRU	VALVE DEPENDS ON ISOLATION REQUIREMENTS. SEE PARAGRAPH 6-3.		
L 052			
M 001	AMMETER 0-50 MA DC FULL SCALE DEFLECTION, MFR 89661, PART NO. 331C146H09		TEST METER
M 002			
THRU	NOT USED		
M 099			
P 001	CONNECTOR, PLUG, ELECTRICAL COAXIAL TYPE, 1 FEMALE CONTACT, 500 V PEAK, UG21D/U, MS91236		RF OUTPUT
P 002	SAME AS P1		RF OUTPUT
P 003	SAME AS P1		RF OUTPUT
P 004	SAME AS P1		RF OUTPUT
P 005	SAME AS P1		RF OUTPUT

ORIGINAL

7-7

TABLE
7-1

NAVSHIPS 93803(A)

CU-872/U
PARTS LIST

TABLE 7-1. ANTENNA COUPLER CU-872/U, MAINTENANCE PARTS LIST (CONT.)

REF DESIG	NOTES	NAME AND DESCRIPTION	FUNCTION
P 006		SAME AS P1	RF OUTPUT
P 007		SAME AS P1	RF OUTPUT
P 008		SAME AS P1	RF OUTPUT
P 009		SAME AS P1	RF INPUT
P 010		CONNECTOR, PLUG, ELECTRICAL BAYONETTE TYPE, 500 VOLT PEAK, MFR 96906, MS3106A14S-7S(C)	POWER INPUT
P 011		ADAPTER, CONNECTOR COAXIAL TYPE, TYPE, 500 VOLT PEAK, 2 CONTACTS, UG306/U, MS35368	FILTER CONNECTION
P 012		CONNECTOR, PLUG, ELECTRICAL COAXIAL TYPE, 500 V PEAK, MFR 02660, PART NO. 31-850	FILTER CONNECTION
P 013		SAME AS P11	FILTER CONNECTION
P 014		SAME AS P12	FILTER CONNECTION
P 015 THRU		NOT USED	
P 099			
R 001		RESISTOR, FIXED, COMPOSITION 270,000 OHMS $\pm 10\%$, 1/2 W, RC20GF274K, SPEC MIL-R-11	V11 GRID
R 002		SAME AS R1	V11 GRID
R 003		SAME AS R1	V12 GRID
R 004		SAME AS R1	V12 GRID
R 005		SAME AS R1	V13 GRID
R 006		SAME AS R1	V13 GRID
R 007		SAME AS R1	V14 GRID
R 008		SAME AS R1	V14 GRID
R 009		SAME AS R1	V15 GRID
R 010		SAME AS R1	V15 GRID
R 011		SAME AS R1	V16 GRID
R 012		SAME AS R1	V16 GRID
R 013		SAME AS R1	V17 GRID
R 014		SAME AS R1	V17 GRID
R 015		SAME AS R1	V18 GRID
R 016		SAME AS R1	V18 GRID
R 017		SAME AS R1	V19 GRID
R 018		SAME AS R1	V19 GRID
R 019		SAME AS R1	V20 GRID
R 020		SAME AS R1	V20 GRID
R 021		RESISTOR, FIXED, COMPOSITION 100 OHMS $\pm 5\%$, 1/2 W, RC20GF101J, MIL-R-11	V11 CATHODE
R 022		SAME AS R21	V12 CATHODE
R 023		SAME AS R21	V13 CATHODE
R 024		SAME AS R21	V14 CATHODE
R 025		SAME AS R21	V15 CATHODE
R 026		SAME AS R21	V16 CATHODE

7-8

ORIGINAL

TABLE 7-1. ANTENNA COUPLER CU-872/U, MAINTENANCE PARTS LIST (CONT.)

REF DESIG	NOTES	NAME AND DESCRIPTION	FUNCTION
R 027	SAME AS R21		V17 CATHODE
R 028	SAME AS R21		V18 CATHODE
R 029	SAME AS R21		V19 CATHODE
R 030	SAME AS R21		V20 CATHODE
R 031	SAME AS R21		V11 CATHODE
R 032	SAME AS R21		V12 CATHODE
R 033	SAME AS R21		V13 CATHODE
R 034	SAME AS R21		V14 CATHODE
R 035	SAME AS R21		V15 CATHODE
R 036	SAME AS R21		V16 CATHODE
R 037	SAME AS R21		V17 CATHODE
R 038	SAME AS R21		V18 CATHODE
R 039	SAME AS R21		V19 CATHODE
R 040	SAME AS R21		V20 CATHODE
R 041	RESISTOR, FIXED, COMPOSITION 160 OHMS ±5%, 1/2 WATT, RC20GF161J, MIL-R-11		V1 CATHODE
R 042	SAME AS R41		V1 CATHODE
R 043	SAME AS R41		V2 CATHODE
R 044	SAME AS R41		V2 CATHODE
R 045	SAME AS R41		V3 CATHODE
R 046	SAME AS R41		V3 CATHODE
R 047	SAME AS R21		V4 CATHODE
R 048	SAME AS R21		V4 CATHODE
R 049	SAME AS R21		V5 CATHODE
R 050	SAME AS R21		V5 CATHODE
R 051	SAME AS R41		V6 CATHODE
R 052	SAME AS R41		V6 CATHODE
R 053	SAME AS R41		V7 CATHODE
R 054	SAME AS R41		V7 CATHODE
R 055	SAME AS R41		V8 CATHODE
R 056	SAME AS R41		V8 CATHODE
R 057	SAME AS R21		V9 CATHODE
R 058	SAME AS R21		V9 CATHODE
R 059	SAME AS R21		V10 CATHODE
R 060	SAME AS R21		V10 CATHODE
R 061			
THRU	NOT USED		
R 070			
R 071	RESISTOR, FIXED, COMPOSITION 620 OHMS ±5%, 2 WATT, RC42GF621J, MIL-R-11		V1 CATHODE
R 072	SAME AS R71		V2 CATHODE
R 073	SAME AS R71		V3 CATHODE
R 074	SAME AS R71		V4 CATHODE
R 075	SAME AS R71		V5 CATHODE
R 076	SAME AS R71		V6 CATHODE
R 077	SAME AS R71		V7 CATHODE
R 078	SAME AS R71		V8 CATHODE
R 079	SAME AS R71		V9 CATHODE

TABLE
7-1

NAVSHIPS 93803(A)

CU-872/U
PARTS LIST

TABLE 7-1. ANTENNA COUPLER CU-872/U, MAINTENANCE PARTS LIST (CONT.)

REF DESIG	NOTES	NAME AND DESCRIPTION	FUNCTION
R 080		SAME AS R71	V10 CATHODE
R 081		RESISTOR, FIXED, COMPOSITION 620,000 ±5%, 1/2 W, RC20GF624J, SPEC MIL-R-11	V1 CATHODE METERING
R 082		SAME AS R81	V2 CATHODE METERING
R 083		SAME AS R81	V3 CATHODE METERING
R 084		SAME AS R81	V4 CATHODE METERING
R 085		SAME AS R81	V5 CATHODE METERING
R 086		SAME AS R81	V6 CATHODE METERING
R 087		SAME AS R81	V7 CATHODE METERING
R 088		SAME AS R81	V8 CATHODE METERING
R 089		SAME AS R81	V9 CATHODE METERING
R 090		SAME AS R81	V10 CATHODE METERING
R 091		RESISTOR, FIXED, COMPOSITION 680 OHMS ±5%, 1/2 W, RC20GF681J, SPEC MIL-R-11	PLATE LINE TERMINATION
R 092		SAME AS R91	PLATE LINE TERMINATION
R 093		RESISTOR, FIXED, COMPOSITION 300 OHMS ±5%, 1/2 W, RC20GF301J, SPEC MIL-R-11	GRID LINE TERMINATION
R 094		SAME AS R93	GRID LINE TERMINATION
R 095		RESISTOR, FIXED, FILM 75 OHMS ±1%, 1/2 W, RN70B75R0F, SPEC MIL-R-10509	HYBRID BALANCE
R 096		SAME AS R95	HYBRID BALANCE
R 097		SAME AS R95	HYBRID BALANCE
R 098		SAME AS R95	HYBRID BALANCE
R 099		SAME AS R95	HYBRID BALANCE
S 001		SWITCH, TOGGLE DPDT, 25 AMP, 125 V AC, 6 SCREW TYPE TERMINALS, MS35059-22, SPEC MIL-S-3750	POWER ON-OFF
S 002		SWITCH, ROTARY SINGLE SECTION, NON SHORTING, 12 CONTACTS, MFR 89661, PART NO. 327C752H01	TEST METER
S 003 THRU S 099		NOT USED	
T 001		TRANSFORMER, RADIO FREQUENCY 1 PRIMARY 1 TO 36 MC, 1 SECONDARY	GRID INPUT

CU-872/U
PARTS LIST

NAVSHIPS 93803(A)

TABLE
7-1

TABLE 7-1. ANTENNA COUPLER CU-872/U, MAINTENANCE PARTS LIST (CONT.)

REF DESIG	NOTES	NAME AND DESCRIPTION	FUNCTION
T 002		CENTER TAPPED, 17 VOLT WORKING, MFR 89661, PART NO. 342C486H01 TRANSFORMER, RADIO FREQUENCY 1 PRIMARY 1 TO 36 MC 1 SECONDARY	PLATE COUPLING
T 003		CENTER TAPPED, 184 V WORKING, MFR 89661, PART NO. 342C490H01. TRANSFORMER, RADIO FREQUENCY 1 TO 40 MC, 2 SECONDARY, 7.1 VOLT WORKING 0.4 W, MFR 89661, PART NO. 342C989H01	HYBRID
T 004		SAME AS T3	HYBRID
T 005		SAME AS T3	HYBRID
T 006		SAME AS T3	HYBRID
T 007		SAME AS T3	HYBRID
T 008		SAME AS T3	HYBRID
T 009		SAME AS T3	HYBRID
T 010		SAME AS T3	HYBRID
T 011		TRANSFORMER, POWER, STEP-UP AND STEP-DOWN 115/230 V, 60 CYCLE, 236 V AC INPUT, 6.3 V AC OUTPUT, MFR 96175, PART NO. 31740	POWER
T 012		TRANSFORMER, RADIO FREQUENCY 1 PRIMARY 1 TO 40 MC, 2 SECONDARY 7.1 V WORKING, MFR 89661, PART NO. 342C989H02	RF INPUT
T 013 THRU T 099		NOT USED	
TB 001		TERMINAL BOARD 10 TERMINALS, MFR 00779, PART NO. 480064-3	INTERCONNECTION
TB 002		SAME AS TB1	INTERCONNECTION
TB 003		SAME AS TB1	INTERCONNECTION
TB 004		SAME AS TB1	INTERCONNECTION
TB 005		SAME AS TB1	INTERCONNECTION
TB 006		SAME AS TB1	INTERCONNECTION
TB 007		SAME AS TB1	INTERCONNECTION
TB 008		SAME AS TB1	INTERCONNECTION
TB 009 THRU TB 099		NOT USED	
V 001		ELECTRON TUBE DUAL TRIODE, 6922, SPEC MIL-E-1C	1ST DISTRIBUTED AMPLIFIER
V 002		SAME AS V1	2ND DISTRIBUTED AMPLIFIER
V 003		SAME AS V1	3RD DISTRIBUTED AMPLIFIER
V 004		SAME AS V1	4TH DISTRIBUTED AMPLIFIER
V 005		SAME AS V1	5TH DISTRIBUTED AMPLIFIER

ORIGINAL

7-11

TABLE
7-1

NAVSHIPS 93803(A)

CU-872/U
PARTS LIST

TABLE 7-1. ANTENNA COUPLER CU-872/U, MAINTENANCE PARTS LIST (CONT.)

REF DESIG	NOTES	NAME AND DESCRIPTION	FUNCTION
V 006	SAME AS V1		1ST DISTRIBUTED AMPLIFIER
V 007	SAME AS V1		2ND DISTRIBUTED AMPLIFIER
V 008	SAME AS V1		3RD DISTRIBUTED AMPLIFIER
V 009	SAME AS V1		4TH DISTRIBUTED AMPLIFIER
V 010	SAME AS V1		5TH DISTRIBUTED AMPLIFIER
V 011	SAME AS V1		1ST DISTRIBUTED AMPLIFIER
V 012	SAME AS V1		2ND DISTRIBUTED AMPLIFIER
V 013	SAME AS V1		3RD DISTRIBUTED AMPLIFIER
V 014	SAME AS V1		4TH DISTRIBUTED AMPLIFIER
V 015	SAME AS V1		5TH DISTRIBUTED AMPLIFIER
V 016	SAME AS V1		1ST DISTRIBUTED AMPLIFIER
V 017	SAME AS V1		2ND DISTRIBUTED AMPLIFIER
V 018	SAME AS V1		3RD DISTRIBUTED AMPLIFIER
V 019	SAME AS V1		4TH DISTRIBUTED AMPLIFIER
V 020	SAME AS V1		5TH DISTRIBUTED AMPLIFIER
V 021	ELECTRON TUBE MINIATURE DIODE, 6627/0B2WA, SPEC MIL-E-1C		BIAS REFERENCE
V 022 THRU V 099	NOT USED		
XC 001 THRU XC 071	NOT USED		
XC 072		SOCKET, ELECTRON TUBE 8 CONTACTS, BOTTOM MOUNTING, SADDLE TYPE, TS101P01, SPEC MIL-S-12883	SOCKET FOR C72
XC 073 THRU XC 076	NOT USED		
XC 077	SAME AS XC72		SOCKET FOR C77
XC 078 THRU XC 099	NOT USED		
XDS001		LAMPHOLDER MINIATURE, RED LENS, FOR T-3 1/4 BULB, LH62BR2,	HOLDER FOR DS001

CU-872/U
PARTS LIST

NAVSHIPS 93803(A)

TABLE
7-1

TABLE 7-1. ANTENNA COUPLER CU-872/U, MAINTENANCE PARTS LIST (CONT.)

REF DESIG	NOTES	NAME AND DESCRIPTION	FUNCTION
	SPEC MIL-L-3661		
XDS002 THRU XDS099 XF 001	NOT USED		
		FUSEHOLDER NON-INDICATING, 15 AMPS, 250 V, FHN20G, MIL-F-19207	SOCKET FOR F1
XF 002		SAME AS XF1	SOCKET FOR F2
XF 003		SAME AS XF1	SOCKET FOR F3
XF 004		SAME AS XF1	SOCKET FOR F4
XF 005 THRU XF 099 XV 001	NOT USED		
		SOCKET, ELECTRON TUBE 9 PIN, MOLDED PLASTIC, TS103P01, SPEC MIL-S-12883.	SOCKET FOR V1
XV 002		SAME AS XV1	SOCKET FOR V2
XV 003		SAME AS XV1	SOCKET FOR V3
XV 004		SAME AS XV1	SOCKET FOR V4
XV 005		SAME AS XV1	SOCKET FOR V5
XV 006		SAME AS XV1	SOCKET FOR V6
XV 007		SAME AS XV1	SOCKET FOR V7
XV 008		SAME AS XV1	SOCKET FOR V8
XV 009		SAME AS XV1	SOCKET FOR V9
XV 010		SAME AS XV1	SOCKET FOR V10
XV 011		SAME AS XV1	SOCKET FOR V11
XV 012		SAME AS XV1	SOCKET FOR V12
XV 013		SAME AS XV1	SOCKET FOR V13
XV 014		SAME AS XV1	SOCKET FOR V14
XV 015		SAME AS XV1	SOCKET FOR V15
XV 016		SAME AS XV1	SOCKET FOR V16
XV 017		SAME AS XV1	SOCKET FOR V17
XV 018		SAME AS XV1	SOCKET FOR V18
XV 019		SAME AS XV1	SOCKET FOR V19
XV 020		SAME AS XV1	SOCKET FOR V20
XV 021		SOCKET, ELECTRON TUBE 7 CONTACTS, W/BODY SHIELD BASE, TS102P01, SPEC MIL-S-12883	SOCKET FOR V21
XV 022 THRU XV 099 Z 001	NOT USED		
		FILTER, RADIO INTERFERENCE 250 V, 3 AMP POWER INPUT, 600 V, 60 CYCLE 3 AMP, MFR 81831, PART NO. FA3692C.	POWER INPUT
Z 002		RADIO FREQUENCY INPUT ASSEMBLY C/O 4 CONNECTORS, 15 CAPACITORS, 9 COILS, 2 RESISTORS AND NECESSARY HARDWARE, MFR 89661, PART NO. 484D800G01.	RF INPUT
Z 003 THRU	NOT USED		

ORIGINAL

7-13

TABLE
7-1

NAVSHIPS 93803(A)

CU-872/U
PARTS LIST

TABLE 7-1. ANTENNA COUPLER CU-872/U, MAINTENANCE PARTS LIST (Cont.)

REF DESIG	NOTES	NAME AND DESCRIPTION	FUNCTION
Z 099			
R 100		SAME AS R95	HYBRID BALANCE
R 101		RESISTOR, FIXED, FILM 75 OHMS ±1%, 2 W, RN30X75R0F, SPEC MIL-R-10509	HYBRID BALANCE
R 102		SAME AS R101	HYBRID BALANCE
R 103		SAME AS R95	HYBRID BALANCE
R 104		SAME AS R95	HYBRID BALANCE
R 105		SAME AS R95	HYBRID BALANCE
R 106		SAME AS R95	HYBRID BALANCE
R 107		SAME AS R95	HYBRID BALANCE
R 108		RESISTOR, FIXED, COMPOSITION 20,000 OHMS ±5%, 2 WATT, RC42GF203J, SPEC MIL-R-11	BIAS REGULATOR
R 109		SAME AS R108	BIAS REGULATOR
R 110		RESISTOR, FIXED, FILM 13,300 OHMS ±1%, 1/2 W, RN70B1332F, SPEC MIL-R-10509	GRID VOLTAGE DIVIDER
R 111		RESISTOR, FIXED, FILM 53,600 OHMS ±1%, 1/2 W, RN70B536F, SPEC MIL-R-10509	GRID VOLTAGE DIVIDER
R 112		RESISTOR, FIXED, COMPOSITION 51 OHMS ±5%, 1/2 W, RC20GF510J, SPEC MIL-R-11	B PLUS SPIKE SUPPRESSOR
R 113		RESISTOR, FIXED, COMPOSITION 39,000 OHMS ±10%, 2 W, RC42GF393K, SPEC MIL-R-11	B PLUS BLEADER
R 114		RESISTOR, FIXED, COMPOSITION 130 OHMS ±5%, 1/2 W, RC20GF131J, SPEC MIL-R-11	B PLUS METERING
R 115		RESISTOR, FIXED, COMPOSITION 30,000 OHMS ±5%, 1/2 W, RC20GF300J, MIL-R-11	B PLUS METERING
R 116		NOT USED	
R 117		SAME AS R115	BIAS FILTERING
R 118		SAME AS R91	GRID BIAS DECOUPLING
R 119 THRU		NOT USED	
R 199			
C 201		CAPACITOR, FIXED, MICA DIELECTRIC 12 UUF ±10%, 500 V DC WORKING, MFR P2136, PART NO. DM15(12UUF±10%)	INPUT FILTER
C 202		CAPACITOR, VARIABLE, GLASS DIELECTRIC 0.8 TO 18 UUF, 1000 VDC WORKING, MFR 73899, PART NO. VC4G	INPUT FILTER
C 203		CAPACITOR, FIXED, MICA DIELECTRIC 82 UUF ±2%, 500 V DC WORKING, MFR 72136, PART NO. DM15(82UUF±2%)	INPUT FILTER
C 204		SAME AS C202	INPUT FILTER
C 205		SAME AS C203	INPUT FILTER

CU-872/U
PARTS LIST

NAVSHIPS 93803(A)

TABLE
7-1

TABLE 7-1. ANTENNA COUPLER CU-872/U, MAINTENANCE PARTS LIST (CONT.)

REF DESIG	NOTES	NAME AND DESCRIPTION	FUNCTION
C 206	SAME AS C202		INPUT FILTER
C 207	SAME AS C201		INPUT FILTER
C 208	SAME AS C202		INPUT FILTER
C 209	CAPACITOR, FIXED, MICA DIELECTRIC 1100 UUF ±2%, 500 V DC WORKING, MFR 72136, PART NO. DM20(1100UUF±2%)		INPUT FILTER
C 210	CAPACITOR, FIXED, MICA DIELECTRIC 750 UUF ±2%, 500 V DC WORKING, MFR 72136, PART NO. DM20(750UUF±2%)		INPUT FILTER
C 211	CAPACITOR, VARIABLE, CERAMIC DIELECTRIC 45 UUF, 500 V DC WORKING, CV11C450, SPEC MIL-C-81		INPUT FILTER
C 212	CAPACITOR, FIXED, MICA DIELECTRIC 620 UUF ±2%, 500 V DC WORKING, MFR 72136, (ART NO. DM20(620UUF±2%))		INPUT FILTER
C 213	SAME AS C210		INPUT FILTER
C 214	SAME AS C211		INPUT FILTER
C 215	SAME AS C209		INPUT FILTER
C 216			
THRU	NOT USED		
C 299			
E 201	INSULATOR, STANDOFF 5/8 IN. LG, 1/4 IN. ACROSS FLATS, MFR 89661, PART NO. 54B7174H01		STANDOFF
E 202	SAME AS E201		STANDOFF
E 203	SAME AS E201		STANDOFF
E 204	SAME AS E201		STANDOFF
E 205	SAME AS E201		STANDOFF
E 206	SAME AS E201		STANDOFF
E 207	SAME AS E201		STANDOFF
E 208	SAME AS E201		STANDOFF
E 209			
THRU	NOT USED		
E 299			
J 201	CONNECTOR, RECEPTACLE, ELECTRICAL 1 CONTACT, PLASTIC BODY, UG-1094/U, MS35179(SC)		FILTER CONNECTION
J 202	SAME AS J201		FILTER CONNECTION
J 203	SAME AS J201		FILTER CONNECTION
J 204	SAME AS J201		FILTER CONNECTION
J 205			
THRU	NOT USED		
J 299			
L 201	COIL, RADIO FREQUENCY 2000 MA .07 OHMS, 0.33 UH ±5%, MFR 89661, DWG 54B7108H53		INPUT FILTER

TABLE
7-1

NAVSHIPS 93803(A)

CU-872/U
PARTS LIST

TABLE 7-1. ANTENNA COUPLER CU-872/U, MAINTENANCE PARTS LIST (CONT.)

REF DESIG	NOTES	NAME AND DESCRIPTION	FUNCTION
L 202		SAME AS L201	INPUT FILTER
L 203		COIL, RADIO FREQUENCY 2000 MA, .08 OHMS, 0.47 UH ±5%, MFR 89661, DWG 54B7108H54	INPUT FILTER
L 204		SAME AS L201	INPUT FILTER
L 205		SAME AS L201	INPUT FILTER
L 206		COIL, RADIO FREQUENCY VARIABLE, 8.5 UH TO 14.5 UH, CERAMIC CORE, MFR 98821, PART NO. 1000E	INPUT FILTER
L 207		COIL, RADIO FREQUENCY 1700 MA, 3.3 UH ±5%, MFR 89661, DWG 54B7108H55	INPUT FILTER
L 208		SAME AS L207	INPUT FILTER
L 209		SAME AS L206	INPUT FILTER
R 201		RESISTOR, FIXED, FILM 10 OHMS ±1%, 1/2 W, MFR 89661, PART NO. 54B7057H01	INPUT FILTER
R 202		SAME AS R201	INPUT FILTER
B 301		FAN, CENTRIFUGAL TYPE-BA-LEFT MFR 89661, PART NO. 490D670H01	CABINET COOLING

TABLE 7-2. ANTENNA COUPLER CU-872/U, LIST OF MANUFACTURERS

MFR CODE	NAME	ADDRESS
02660	American Phenolic Corporation	Chicago, Illinois
07387	Birtcher Corporation	North Los Angeles, California
13499	Collins Radio Company	Cedar Rapids, Iowa
49956	Raytheon Manufacturing Company	Waltham, Mass.
71779	Cambridge Thermionic Corporation	Cambridge, Mass.
72136	Electro Motive Manufacturing Company	Willimantic, Conn.
73389	Freed Transformer Company	New York, New York
73899	J F D Manufacturing Company, Inc.	Brooklyn, New York
74956	Jeffers Electronics Corporation	St. Mary's, Pennsylvania
81312	Winchester Electronics Company, Inc.	Norwalk, Conn.
81831	Filtron Company, Inc.	Flushing, Long Island, N. Y.
81931	Kerkling and Company, Inc.	Burbank, California
82142	Jeffers Electronics Corporation	DuBois, Pennsylvania
89661	Westinghouse Electric Company	Baltimore, Maryland
89775	Raytheon Manufacturing Company	Towson, Maryland
96175	Hermetic Seal Transformer Company	Garland, Texas
96906	Military Standards	
98291	Seaelectro, Corporation	New Rochelle, New York
98821	North Hills Electric Company	Great Neck, Long Island, N. Y.

