

EN

**RESTRICTED**

**Section 2**  
**ANTENNAS AND TRANSMISSION LINES**

## SECTION 2. ANTENNAS AND TRANSMISSION LINES

### CLEANING INSULATORS

The Bureau has received information to the effect that decreased transmitter signal strength can often be traced to dirty and salt incrustated insulators, particularly to those in the antenna circuit of low-power transmitters. Also, the erroneous painting of insulators on certain vessels has contributed to a decrease in signal strength. In some instances, the measured resistance of the salt incrustated insulators was found to be as low as 30,000 ohms.

When such a condition exists, a thorough cleaning of the insulator will raise the insulation resistance to the original value and improve output. One yard has been using carbon tetrachloride as a solvent and found it to be very effective. However, in the case of a salt deposit only, it is believed that fresh water will accomplish the desired results.

Obviously, insulators should not be painted, since the metallic content of the paint destroys the insulation value. Nevertheless, this frequently happens, and in such cases, paint removers (i.e. strong caustics) followed by a soap and water bath will restore the insulation value. Care should be taken not to scratch the glazed surfaces of insulators with scraping tools and scratch brushes. A fibre bristle scrub brush should be sufficient for this work.

### PROPER TREATMENT OF RADIO ANTENNA SYSTEMS

Paint, varnish, shellac, grease or any other form of coating *shall not* be applied to any portion of ceramic or phenolic insulating materials forming a part of any radio antenna system.

### INTERCHANGEABILITY OF INSULATORS

Insulators having the same basic five (5) digit Navy type number may be used interchangeably

without regard to the suffix letter immediately following the number. Suffix letters indicate a change from the original, but usually mean only a change in color, glaze, etc. They generally do not affect the mechanical and electrical interchangeability of the insulators.

### BOWL INSULATORS

Caution must be exercised in tightening metal hardware on bowl insulators. One instance of damage to insulator bowls occurred when the hardware was tightened in a tropical climate causing excessive stress on the insulator when the ship reached a cold climate. Obviously temperature expansions and contractions must be considered when installing glass or ceramic material insulators.

—U. S. S. *San Francisco*

### ANTENNA LEAKAGE RESISTANCE

The Bureau of Ships Manual, Chapter 67, paragraph 67-146 requires that all antennas be megged monthly as a test of their insulation resistance to ground. In this connection, the following suitable values are suggested:

(1) A resistance of 200 megohms to ground or more indicates an antenna in good condition.

(2) A resistance of from 5 to 100 megohms to ground indicates need of cleaning insulators.

(3) A resistance of less than 5 megohms to ground indicates immediate and urgent need for locating the leak in the antenna and taking the steps necessary to restore the system to its original condition.

### CONSTRUCTION OF A STANDARD DUMMY ANTENNA

In aligning certain model receivers, such as the RBB/RBC, the instruction book specifies that the signal generator shall be connected to the

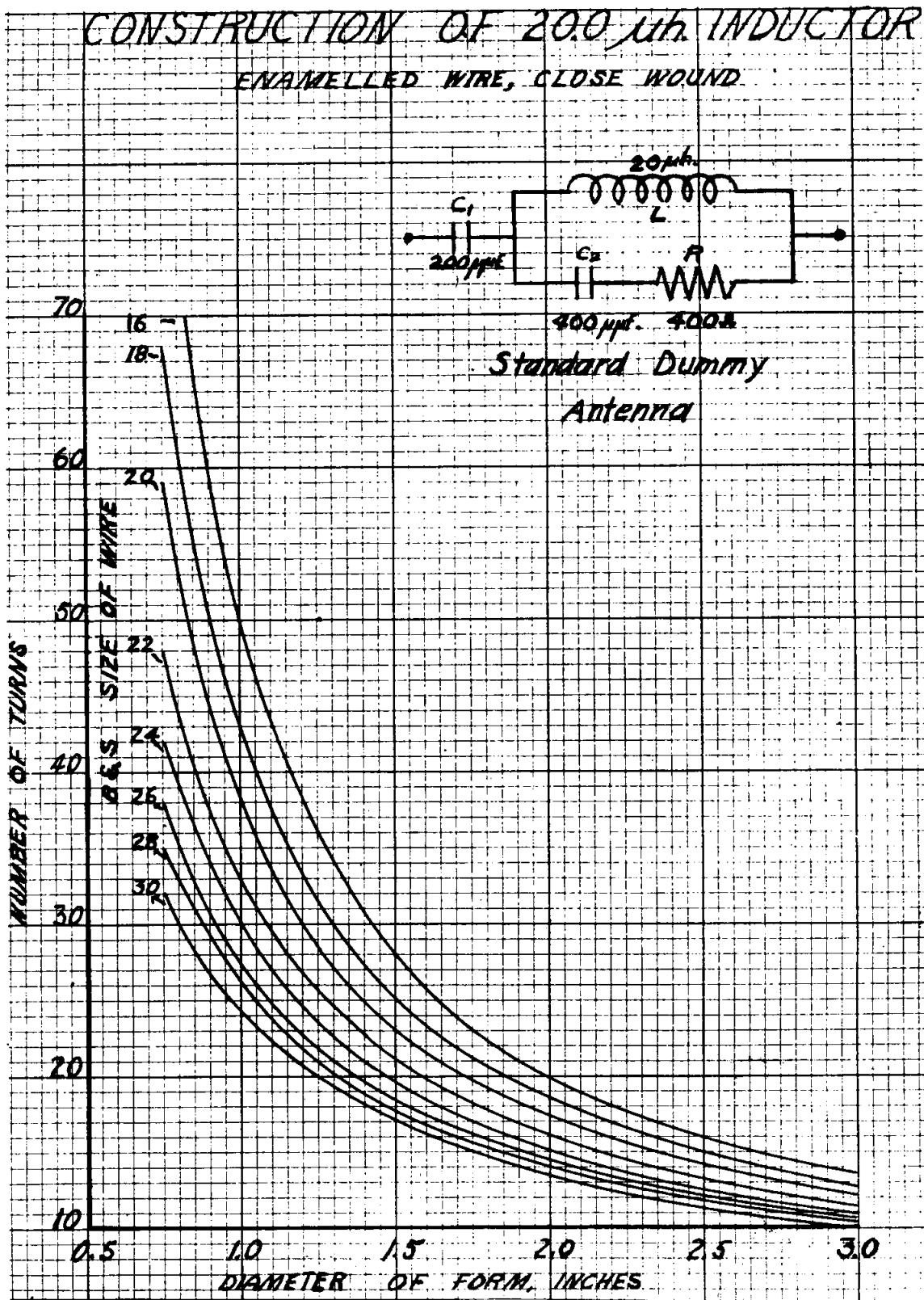

FIGURE 1.—Data for constructing a dummy antenna.

antenna terminal of the receiver through a standard dummy antenna. This insures that the input circuit of the receiver will function in a normal manner without detuning, etc. (in the RBB/RBC equipments care should be taken that the antenna transfer links are connected in the *antenna* position while aligning).

The standard dummy antenna is made in accordance with specifications laid down by the Institute of Radio Engineers Standards Committee on Radio Receivers. It is furnished as a part of the model LP standard signal generator, but for the information of those who do not have the model LP at hand and wish to construct a standard dummy antenna, the following information is supplied.

The standard dummy antenna is a network of lumped impedances which closely approximates the electrical properties of a standard antenna over a wide frequency range. A standard antenna is defined by the Institute of Radio Engineers booklet "Standards on Radio Receivers, 1938" as "an open single wire antenna (including the lead-in wire) having an effective height of 4 meters and having, at frequencies between 540 and 1600 kilocycles, substantially the same impedance as a series circuit containing a capacitance of 200 micromicrofarads, a self-inductance of 20 microhenries and a resistance of 25 ohms. Its fundamental frequency is approximately 2500 kilocycles. Its characteristic resistance is approximately 550 ohms, and its geometric mean impedance in the frequency range of its harmonic frequencies is approximately 400 ohms resistance."

The elements of the standard dummy antenna are condensers (C1 and C2) of 200 and 400 micromicrofarads respectively, an inductor (L) of 20 microhenries, and a resistor (R) of 400 ohms connected as shown in Figure 1. No physical arrangement is shown as the many types of jacks and fittings on various signal generators preclude a universal layout. It should wherever possible be made compactly and be enclosed in a metallic case which should be grounded. The parts should be so arranged that the capacity between any two points is as small as practicable. The effective values of all components should be within 10 percent of the nominal values. Winding data for the inductor (L) of 20 microhenries inductance is given in the curves of Figure 1.

When in use, the dummy antenna is connected between the "high" side of the signal generator and the "antenna" post of the receiver. The "low" side of the signal generator is connected to the chassis of the receiver and to ground.

### WHAT DOES ANTENNA CURRENT MEAN?

"Meter inoperative, evidently burnt out. 0-5 ampere range seems too low. We find it difficult to keep antenna current this low on most frequencies.—USS ———." This report is made frequently. Here is another typical report. ". . . by changing the length of the antenna, the current was raised from 1 ampere to 2 amperes, thereby increasing our field strength. . . ." This statement is incorrect. The operator merely moved the standing wave relative to the ammeter to bring a high-current part of the standing wave on to the ammeter. The field strength did not necessarily change, and the operator had to record new adjustment settings for his loading circuit due to the altered input impedance of the antenna. It is believed that the following short discussion will prove helpful to the understanding of the distribution of current in an antenna system.

Figure 1 shows an antenna system with the

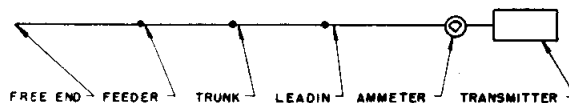

FIGURE 1.—An antenna system.

parts drawn stretched out in a line. Figure 2 shows a standing wave of current on an antenna system. The shape of the loops is supposed to be sinusoidal, but these curves will suffice for discussion purposes. Length in the horizontal direction means "distance along a wire". Height in the vertical direction means "quantity of current in the wire". The curves show the amount of current at any point in the wire. The current in a standing wave is not the same all along the wire, but varies as shown in Figure 2. There are

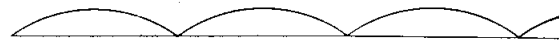

FIGURE 2.—A standing wave of current.

several ways to draw a standing wave, but the one shown is one of the best because it shows all current as positive, or above the zero line, which is the only way a thermocouple-ammeter can indicate it. In practice, the standing wave is not as smooth as shown, but is partly irregular due to changes in surge impedance along the length of the antenna system.

Consider a standing wave for a frequency of two megacycles. Its half-wavelength is computed by dividing the frequency in megacycles into 492 feet. The answer in this example is 246 feet which means that there will be 246 feet between the nulls or zero-points of the standing wave (see Figure 3). This distance between nulls is called a half-wavelength. Notice that all points separated by a half-wavelength have the same amount of current in them.

Figure 4 shows how much current the ammeter will indicate for various combinations of antenna length and standing wave. The antenna's length is fixed aboard ship, but the standing wave's length varies with the frequency as described above. Each example has a note beside it giving

an estimate of the current. The antennas are drawn spread out, like the one in Figure 1. Actually each antenna can be of any length, and each standing wave can be of any frequency, provided the standing wave and antenna fit each other as shown in the figure.

The conditions shown in Figure 4 will occur when the ammeter is connected between the an-

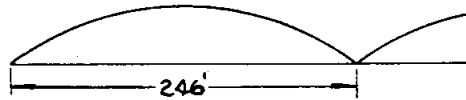

FIGURE 3.—A half-wave at two megacycles.

tenna and the loading reactors of the transmitter—which is usually the connection used. In a very few cases, the transmitter utilizes a different connection, with the ammeter in the loading circuit, and then the readings depend on the tuning as well as the antenna lengths.

The most useful services that the ammeter can perform are:

(1) On frequencies for which the antenna current happens to be large enough at the location of

Meter reads ZERO (Half-wave-length antenna)

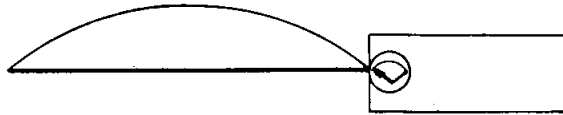

Meter reads LOW (Antenna very short compared to wavelength in use)

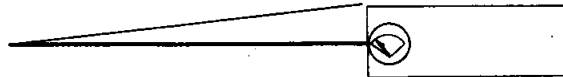

Meter reads ZERO (Antenna equal to wavelength or any whole number of half-wavelengths)



Meter reads VERY HIGH, and may burn out. (Antenna length is an odd number of quarter-wavelengths)

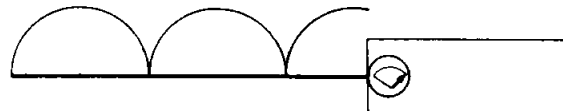

Meter reads several amperes (Antenna length is not any of the above cases)



FIGURE 4.—Ammeter readings for various combinations of antennas and frequencies.

the ammeter to indicate some current, one can be sure that modulation is occurring by watching the ammeter move during speech or mow transmissions. The meter usually moves slowly and reads only 22.5 percent extra current during 100 percent modulation. (A superior modulation indicator would be a monitor built for the purpose, with which an oscilloscope or headphone indication is used.)

If the ammeter indicates a readable current, then it can be used as a carrier indicator because the current reading will drop if the carrier fails. However, this function is not important as the final plate ammeter and other meters will indicate the same thing. Another excellent carrier indicator consists of a neon bulb loosely coupled to the antenna. This also makes a satisfactory modulation checker.

(3) If the ammeter current is readable and if the antenna (or dummy antenna) input resistance is known, then the power output of the antenna may be computed. In general, the radio-man does not know the antenna resistance.

(4) If the ammeter current is readable it can be used as a guide for further tuning of any stage in the transmitter. However, the transmitter is usually equipped with other meters for tuning the transmitter correctly.

(5) The antenna ammeter is useful for the indication of accidental changes in the transmitter output or in the antenna impedance (due to grounds, etc.) provided that the correct reading for the frequency in use is recorded and checked frequently. This action is also equally well accomplished by observing the final plate ammeter.

(6) The antenna ammeter is often useful when reducing the output power, since reducing the antenna current to half its normal value will reduce the radiated power to one quarter its normal value.

It should now be evident that the antenna current meter is useful, but not a necessity, and that in a given installation it can indicate any current from zero to off-scale, the value depending on the frequency as well as on the amount of power fed to the antenna.

What to do when the frequency in use is such that the antenna ammeter indicates zero: **NOTHING!!** Proper use of the *final plate ammeter*

will indicate that power is being fed to the antenna.

What to do when the antenna ammeter is being driven off scale: Try to take action, because the meter may burn out and prevent transmissions until a repair is effected. You may reduce the transmitter power by decreasing the *power fed to the transmitter*.

## TUNING TRANSMITTERS UNDER CONDITIONS OF RADIO SILENCE

### Method

Up to the present time it has been possible to tune all the stages of a transmitter under conditions of radio silence except the power amplifier and antenna circuits, but tuning these circuits has required the emission of power from the antenna. A method has been devised for tuning all the stages of a standard communications transmitter without the necessity for radiation from the antenna. The system does not require any apparatus in addition to that already provided aboard ship. The radio technician should become familiar with the method. He may have to place equipments in operation whose antennas have been shot away, or damaged in some other way by the elements, in which case previous calibrations are of little value with the new antenna rigged to replace the original one.

With all antennas grounded and trunk openings in the radio room sealed off, the adjustment of the m-o and i-p-a stages to the correct frequency and to resonance can be checked with the transmitter in operation. At the same time the power-amplifier stage may be resonated, although antenna and coupling adjustments may subsequently necessitate readjustment of this stage. The transmitter is then shut down and the antenna connected to its antenna terminal.

Adjustment of the antenna circuits to resonance and determination of the proper coupling is accomplished by utilizing the static noise picked up by the antenna. A receiver tuned to the desired output frequency and lightly coupled to the transmitter p-a tube plate is employed to measure the noise level reaching this point. The noise level is indicated on a suitable audio output voltmeter connected to the receiver output. Circuit resonance is obtained by tuning the trans-

mitter output circuits to produce maximum noise output from the receiver. Proper antenna coupling is determined by adjusting coupling and tuning controls until the receiver audio output voltage drops to about one-half when a resistor equal to the load resistance required by the power output tube is connected from the p-a plate to ground.

→ **WARNING:** *Personnel are cautioned to exercise safety precautions and good judgment in carrying out the steps described in the following paragraphs.* ←

**Theory**

The theory of operation can probably best be seen with the aid of an actual antenna circuit. (See Fig. 1.)

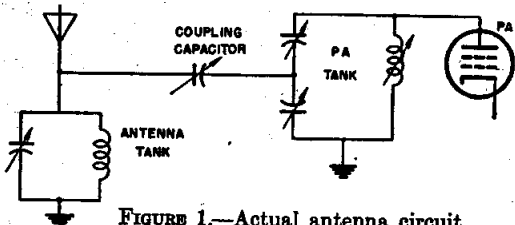

FIGURE 1.—Actual antenna circuit.

The antenna can be represented as an inductance, a capacitance, and a resistance in series with a noise voltage  $e_n$ , as shown in Figure 2.

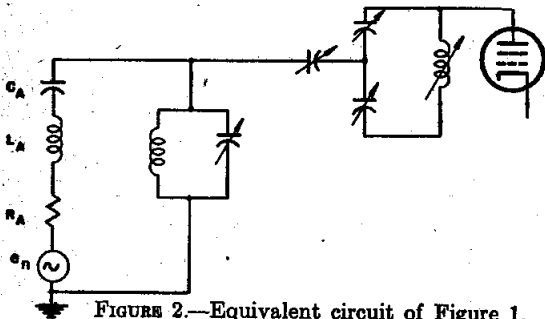

FIGURE 2.—Equivalent circuit of Figure 1.

By tuning the antenna circuit to resonance at the desired frequency, the simplified circuit

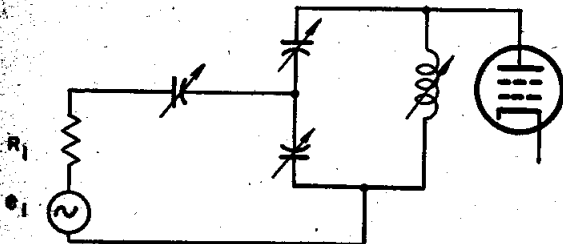

FIGURE 3.—Same as Figure 2, but with the antenna tuned to resonance.

shown in Figure 3 is obtained, where  $R_1$  is a function of  $R_A$  and the ratio of  $L$  and  $C$  in the tuned circuit;  $e_1$  is the noise voltage at the desired frequency.

When the p-a tank circuit is tuned to resonance, the circuit simplifies to a resistance  $R_2$  in series with a noise voltage  $e_2$  where  $R_2$  and  $e_2$  are both dependent on  $R_1$ ,  $e_1$ , and the coupling capacitor. (See Fig. 4.)

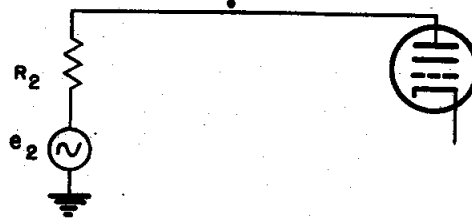

FIGURE 4.—Same as Figure 3, but with the tank circuit tuned to resonance.

With the equipment operating normally as a transmitter the antenna reflects the proper resistance  $R_2$  to the tube to provide proper p-a loading. If it is assumed that the proper resistance is  $R_L$  and is known, then the correct adjustment of the antenna tuning and coupling circuits which will make  $R_2$  equal to  $R_L$  can be determined in the following manner. (See Fig. 5.)

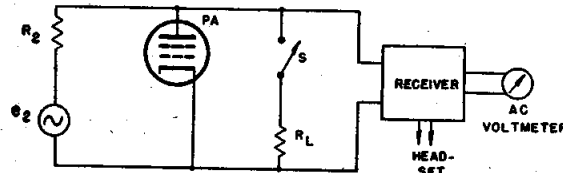

FIGURE 5.—Method of tuning.

With the switch  $S$  open and the receiver tuned to the proper frequency, the gain control is adjusted to give a convenient value of a-c voltage. Closing switch  $S$  should now give a value one-half the previous reading if  $R_L$  equals  $R_2$ . If the second reading is less than one-half, it indicates that  $R_2$  is greater than  $R_L$  and the coupling must be increased. If the second reading is greater than one-half, then  $R_2$  is less than  $R_L$  and the coupling must be decreased.

The limitations of the method should be realized. For instance, when the noise level fluctuates intermittently it will be hard to make adjustments because of the unreliability of the output voltage from the receiver for various adjustments

made during the procedure. However, antenna resonance can be quickly obtained and the degree of coupling between antenna and p-a tank can be approximated. Even if full power output is not obtained when the transmitter is used, sufficient power will be radiated, in all probability, to accomplish the desired communication.

### Equipment Required

A good receiver with a *shielded* antenna lead, a one-half watt carbon resistor, and a fairly high impedance one- or two-volt a-c voltmeter are all that are required. The receiver must naturally cover the range of the transmitter. On the lower frequencies the length of the antenna lead is unimportant; however, above 10 mc the length should be kept to four or five feet or less so that it does not approach a quarter wavelength. A coupling capacitor is required as shown in Figure 6.

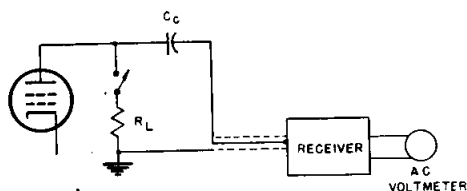

FIGURE 6.—Addition of a capacitor to Figure 5.

This prevents the capacity of the shielded line from detuning the p-a circuit. On the high frequencies, 2 to 18 mc, sufficient coupling may be obtained by twisting an inch or so of insulated wire around the p-a plate lead, while at the low frequencies, 175 to 600 kc, more capacity may be required, such as a 50- to 100-micromicrofarad mica capacitor. The coupling arrangement should be made so that it can be easily connected and disconnected. It also is important to have it arranged so that it is impossible to operate the transmitter with the receiver and resistor attached. It might be mentioned that it is necessary to hear the output of the receiver as well as see the noise voltage produced.

### Determining Resistance $R_L$

Determination of the value of  $R_L$  (Figure 5) to use with any particular transmitter can best be accomplished when conditions permit opera-

tion of the transmitter into an actual antenna. If this course is not permissible, a determination can be made if the transmitter can be fed into a dummy antenna, or if a careful calibration of the transmitter with its antenna is available for any frequency. The values in the table at the end of this assignment can be used if time and circumstances do not permit an individual check on the ship's transmitters.

In those instances where the emission of power is permissible the proper value of resistance for  $R_L$  can be determined as follows:

(1) Tune the transmitter to any frequency and load the power amplifier to the proper value.

(2) Tune the receiver to the frequency of the transmitter.

(3) Shut down the transmitter and couple the receiver to the p-a stage as described in the preceding paragraphs.

(4) Try connecting different values of resistance from the p-a plate to ground until the audio noise voltage obtained with the resistor is one-half of that obtained without it.

Step (4) can be accomplished with greater ease and accuracy if a signal generator such as a model LP is tuned to the same frequency and connected to a wire near the antenna. This produces a steady mcw signal to work with rather than the more erratic static noise.

In those cases where emission is not permissible, the transmitter may be set to any previously calibrated frequency and steps (2) to (4) of the preceding paragraph followed. The LP, of course, cannot be employed under these conditions.

### Tuning the TBK During Radio Silence

(1) With all antennas entering the transmitter room grounded and all trunks closed, start up the transmitter and tune all stages to resonance, including the power amplifier.

(2) Tune a receiver of approved low oscillator radiation to the transmitter output frequency, being careful not to damage the receiver. Connect an audio voltmeter with about a one- or two-volt range to the output of the receiver.

(3) Shut down the transmitter and connect it to the antenna.

(4) Make sure that the voltage is actually removed from the power amplifier by using a



discharge probe, shorting it to ground momentarily. Couple the receiver to the p-a tube plate by wrapping two or three turns of insulated wire around the plate lead. (A more permanent method of coupling can be devised when time permits so that the receiver may be readily attached or disconnected.) The receiver antenna lead should be a four- or five-foot length of shielded wire.

(5) If calibrations are available for the transmitter with the particular antenna, set the antenna controls to the positions indicated for the nearest frequency. If no calibration is available for a frequency reasonably close, set the coupling control at mid-scale and proceed.

(6) With the receiver AVC off, tune the p-a tank circuit until maximum noise output is obtained from the receiver. The correct point is usually quite sharp.

(7) Connect  $R_1$  from the plate of the p-a tube to ground. Then adjust the antenna tuning circuit for maximum noise. The correct point may not be sharp and will require later adjustment. Do not change the coupling adjustment.

(8) Remove  $R_L$  and adjust the receiver sensitivity to give an output of one volt or some other convenient value on the audio output meter.

(9) Connect  $R_L$  from the plate of the p-a tube to ground and note the receiver output voltage. If it is near one-half volt (or half value), the loading is nearly correct. Care should be taken in obtaining the readings to get the average noise voltage and not the peaks.

(10) Closer resonance of the antenna circuit can now be obtained by shifting the antenna tuning dial a few divisions in one direction and repeating steps (8) and (9). If the ratio of voltages increases over that previously obtained, try a few more divisions and repeat the process until a maximum ratio of "voltage with  $R_L$  in to voltage with  $R_L$  out" is obtained.

(11) If the final ratio of step (10) is greater than 0.5 (or a previously determined value), the coupling is too tight and should be decreased. If the ratio is less than 0.5, the coupling should be increased.

(12) If the coupling is changed appreciably, repeat steps (6) to (10) until the final ratio of voltages is correct.

(13) Since the possibility exists that exact resonance will not be attained and the p-a may

overload when an attempt is made to put the transmitter on the air, it is suggested that the p-a plate voltage be decreased about 25 percent to preclude operation of the overload relay. Any necessary trimming adjustments can be rapidly made and the power increased to normal during the first few moments of operation.

### Notes

Reference to the transmitter instruction book should be made in the case of all intermediate-frequency equipments to determine whether the power amplifier is adjusted for maximum output as a final step. On most transmitters in the 175-600 kc range, this is not the case and the p-a tank should not be retuned after setting it to initial resonance. Whichever the procedure, the instructions should be followed in making the adjustments with the receiver. Since the intermediate-frequency equipments such as the TAJ and TAQ work only with capacitive antennas, the antenna tuning and coupling system is considerably simpler and rapid adjustment is possible. With any transmitter, care should be taken to follow step (10) of the above procedure very closely, since the correct resonance point of the antenna circuit cannot be determined by step (7) alone. Since the final result depends on the receiver output being proportional to the applied static voltage, it is important that overload of the receiver be avoided.

Considerable improvement in accuracy can be attained after a few trials; therefore, it is suggested that personnel take every opportunity to practice the procedure when conditions permit operation of the transmitter to check the results.

The following values for  $R_L$  were found to be approximately correct for the transmitters listed below. Resistors were of the half-watt IRC metallized variety.

TBK (Westinghouse) .....	5000 ohms
TAJ (Westinghouse) .....	5000 ohms
TBL-4 (RCA) .....	2800 ohms (IF and HF)
TAQ-5 (GE) .....	1000 ohms
TCK (GE) .....	2200 ohms

### NEW RECEIVING ANTENNA TRANSMISSION LINE SYSTEM

Approval of solid dielectric coaxial cable for radio receiving antenna transmission lines is con-

tained in BuShips multiple address letter FS/S67 (981Ca) dated 20 March 1944. It is anticipated that the replacement of the present type of transmission line with solid dielectric lines will be welcomed by all building and maintenance activities. From an installation viewpoint, there can be no reasonable comparison between the two systems. The amount of material and particularly the labor involved in the new system is negligible when compared with that required for the "Boston" system. However, the Boston system remains the most efficient from an electrical viewpoint when the two are considered as a universal broad coverage shipboard transmission line system. Nevertheless, it has been decided that the slight loss which will be encountered in the new cable system will be acceptable in view of the increased flexibility and the vast reduction in materials, time, and labor involved.

A Bureau type plan has been prepared covering a typical arrangement and all the basic details of the new system. This plan will be used as the "key" or reference plan when preparing detailed individual and group installation plans. Full-size vandyke copies of this plan and certain pertinent reference plans were forwarded with the aforementioned multiple address letter to all yard and district commandants (RMO's) and certain design Supervisors of Shipbuilding. Additional copies and copies for other activities may be obtained upon request to BuShips, Code 930D. If any of the referenced plans are desired, they should be specified in the request.

This new system supersedes the 3" outside-diameter coaxial Boston line as well as all other miscellaneous types of lines now being used in the applicable types of vessels. All transmission line installations designed or planned subsequent to 1 April 1944, and which fall within the cable length limitation of forty feet, shall utilize the basic principles and details involved in this system.

It is not intended that this change in systems effect current detailed installation plans which have been completed, nor installations in progress in which a delay in the delivery of any vessel or a change in any shipbuilding contract would be involved, unless specifically authorized by the Bureau in each individual case. However, all changeovers which will not cause either of the

aforementioned effects may be made at the discretion of the activities involved.

This system is not applicable to battleships, carriers, cruisers, etc., which require one or more lines which exceed the cable length limitation of forty feet. A similar and more elaborate system has been designed for these types of vessels, and is covered by separate type plans.

It is desired to invite particular attention to the type 62119 end seal, and type 62128 junction box fitting utilized in the system. It can be said, without exaggeration, that the success or failure of the new transmission line system depends, primarily, upon the proper use and installation of the cable fittings involved. These particular fittings are laboratory designed and have been adopted after many tests and much consideration. They may appear overly complicated at first, but not so after an analysis. The specified fittings are new to the majority of the installation activities concerned, and it will be necessary for the contractor to either manufacture these items or obtain them from one or more of the probable vendors.

#### RECEIVING ANTENNAS

Numerous activities report from time to time that steel stays are employed as receiving antennas on certain classes of vessels. Several years ago this practice was considered generally acceptable but recent experiences definitely indicate that rigging makes an unreliable antenna, hence a poor antenna. As a result of these experiences, the policy of the Bureau in regard to antenna practice has been changed and rigging is not to be used for receiving antennas regardless of circumstances or conditions. Separate antennas are installed for each receiver wherever practicable. Under certain conditions, operation of two or more receivers on the same antenna is approved but rigging should never be used as a receiving antenna except as a temporary expedient.

#### ANTENNA WIRE FOR SHORE USE

In order to provide a suitable light-weight antenna wire of high tensile strength for shore and advanced base use, the Bureau of Ships has

initiated a procurement to establish a stock at Navy Yard, Mare Island and Navy Yard, New York of the following wire:

AWG	Mare Island coils	New York coils	Approx. feet per coil
#10	60	40	3471
#12	60	40	5518
#14	60	40	8771
#8 (3 strands No. 14)	60	40	2900

This wire has been procured under Contract No. NXsr-55627 from the Copperweld Steel Company. The first 40 percent of the solid #10, #12, and #14 wire will be bare, in 100-pound coils; the remaining 60 percent will be enameled wire on returnable reels holding the same amount of wire. Navy Yard, New York and Navy Yard, Mare Island are expected to maintain an adequate stock of this wire in the future to meet the needs of advanced bases and shore activities.

**IMPROVED METHOD OF ASSEMBLING COUPLING UNIT #49529 USED WITH RG-18/U CABLE**

The Radio Material Office, Navy Yard, Philadelphia, has perfected an alternate method of assembling the coupling unit, type 49529, which has desirable features over that shown in BuShips drawing RE 49Z 257A, operation 10.

If the matching unit of the coupling is drilled as shown in Figure 1, the standard spanner

MATCHING UNIT  
COMPONENT OF COUPLING UNIT  
TYPE 49529

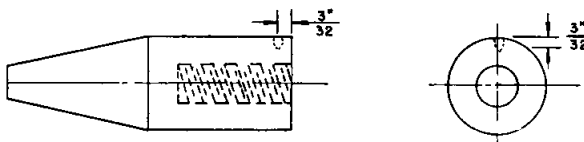

NOTE  
USE DRILL SIZE 30  
(.1285" DIA.)  
REMOVE ALL BURRS

FIGURE 1.—Drilling instructions.

wrench supplied with each inner conductor connector, used in the assembly of the one and five-eighths inch solderless coupling, may be used to replace the adaptor wrench. (See Fig. 2.)

Use of this method provides the additional feature of preventing the matching unit from being turned, while the rest of the inner conductor is being assembled.

COUPLING UNIT, (TYPE 49529)  
FOR USE WITH RG-18/U  
COAXIAL CABLE

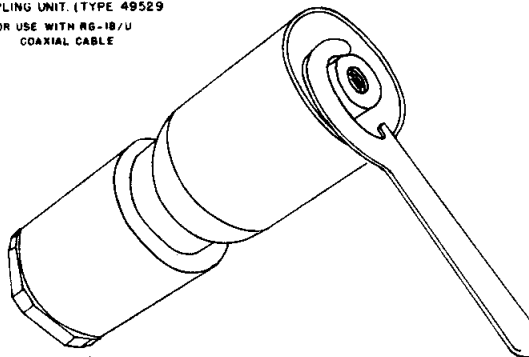

FIGURE 2.—Spanner wrench in position to lock matching unit while completing the assembly of inner conductor connector.

Since these spanner wrenches are available in large numbers at all activities, the cost of making the new adaptor wrenches is eliminated.

**CONNECTING CABLES TO "AN" CONNECTORS**

Specification 15C1 (INT) for Cables, Electric, Insulated, Shipboard Use, page 28, states, "In the case of cables having more than one layer of conductors, the numbering . . . shall be from the innermost to the outermost; i.e., the number one conductor shall be the center conductor." AN cable connectors have prongs designated by the letters A, B, C, etc., starting at the outside circle of prongs and working towards the center. If wire number one is connected to prong A, etc., obviously, transitions or cross-overs will have to be made to permit connection of all wires. The result will be as shown in Figure 1.

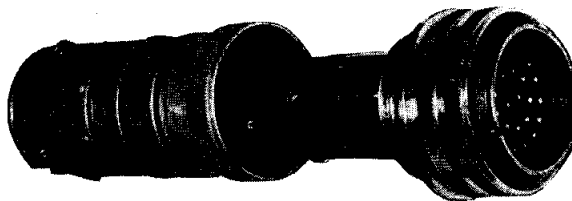

FIGURE 1.—Connector with wire cross-overs.

There is no Navy requirement that the number one conductor be connected to the A pin, number two conductor to B pin, etc. It is therefore recommended that whenever possible the cables be connected with the inside conductors to the inside pins and the outside conductors to the outside pins. The result, as shown in Figure 2, will be a neater, more workmanlike connector, requiring less time and effort to make the connections, and having less danger of shorts or grounds from chafed insulation.

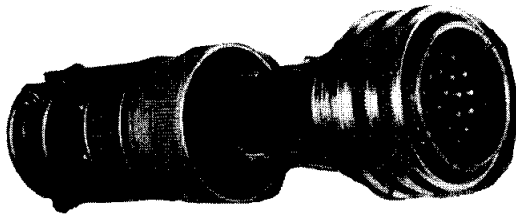

FIGURE 2.—Connector without wire cross-overs.

#### → MAINTENANCE OF STAND-OFF ANTENNA INSULATORS

Chapter 67 of the Bureau of Ships Manual calls for periodic inspection and cleaning of antenna insulators. Failure to comply with such a schedule will result in inefficient operation, as has been evident from several reports received from the fleet. Visual inspection and megger tests should be made to see that the antenna and insulators are in the best of condition.

All stand-off insulators, end-seals of transmission lines, and waveguide windows should be cleaned at least once a month, and more often if conditions warrant such a practice. Aboard submarines, this maintenance should be carried out as soon after surfacing as possible, if the submarine has been operated submerged for over an hour. If the submarine does not submerge for extended periods, this procedure should be practiced at least once a week. The smaller the insulator, end-seal, or waveguide window, the more important is this maintenance procedure.

#### MEGGER ADAPTER FOR TESTING COAXIAL CABLES

Here's another useful beneficial suggestion: It was submitted by Don M. Kinder, civilian worker employed at Puget Sound Naval Ship-

This cleaning must be accomplished thoroughly, with nothing left to chance. Several rinsings should be used to remove accumulated dirt and salt water deposits.

After each cleaning, a coating of Dow-Corning Compound No. 4 should be applied to the entire surface of the insulator. This compound, a jelly-like silicone material, forms a film which water droplets run off of easily, thus affording less opportunity for salt to deposit or dirt particles to adhere to the insulator. The compound can be applied with a clean cloth. Care must be taken that the entire surface is covered with a thin film. Dow-Corning Compound No. 4 is available from all Electronics Supply Offices, and a supply should be carried aboard each vessel for antenna insulator maintenance. 4/1/48.

#### INSTRUCTION PAMPHLET DISTRIBUTION FOR SUBMARINE DUAL-PURPOSE PERISCOPE ANTENNA

Portsmouth Naval Shipyard has prepared preliminary instruction pamphlets (No. B-6002) for the Dual-Purpose Periscope Antenna installed in various submarines. These pamphlets have been distributed as shown above, with the request that cognizant Type Commanders furnish three copies to each submarine equipped with the periscope antenna. Additional copies may be obtained by writing ComSubLant and -Pac.

	<i>Copies</i>
Bureau of Ships.....	2
U.S.N. Underwater Sound Lab.....	6
ComSubLant.....	18
ComSubPac.....	30
ComNavShipydBoston.....	2
ComNavShipydPhila.....	2
ComNavShipydChasn.....	2
ComNavShipydMare.....	2
ComNavShipydSanFran.....	2
ComNavShipydPearl.....	2

1/1/49

yard, and has been approved by the Bureau where its use may be beneficial.

Coaxial lines, cable fittings, jumpers, anten-

nas, and similar equipment are often tested with meggers to detect shorts or faulty insulation. Coaxial lines or other equipment with cable fittings must be tested with the cable fittings in place in order to check the entire line. The coaxial fittings are small, however, and many parts are not readily accessible. Two men, therefore, are necessary to operate the megger satisfactorily—one to hold the megger leads so they won't short, and one to crank the megger and note the dial reading.

This beneficial suggestion enables one man alone to use the megger so that the other man is released for other service. Moreover, the one man will do the job more quickly and with less trouble. Erroneous readings sometimes obtained when the leads are hand-held are eliminated.

The method is to fabricate special adapter fittings into which the cable to be checked may be inserted, and onto which the megger leads may be easily clamped. These adapters are made from ordinary cable fittings, modified as shown in Figure 1. A fitting is chosen which will mate with the cable fitting on the cable under test. A lug in the form of a half-loop is soldered onto the outer conductor of the adapter. A wire is fastened to the inner conductor of the adapter, extending a few inches outside the adapter. This wire is then bent and soldered at the end to form a loop.

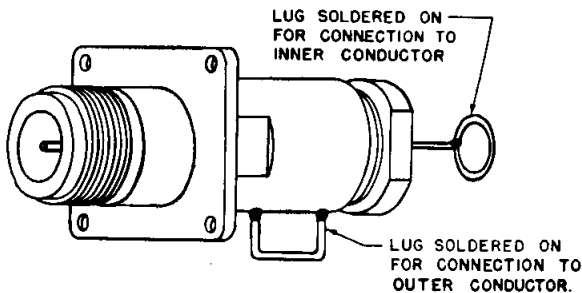

FIGURE 1.—Megger adapter made from Type UG-19B/U Jack. A wire is soldered to the inner conductor of the fitting, brought out a few inches beyond the fitting and doubled back on itself to form a loop. Another wire is soldered to the outer conductor.

Thus two lugs are provided (one to the outer conductor and one to the inner conductor). The megger leads will easily clamp onto these lugs,

with little danger of shorting out. The technician merely plugs the cable into the adapter, clamps on the megger leads, turns the megger crank, and obtains his reading. These adapters have been in use in Shop 67 at Puget Sound for several months, and have proven highly satisfactory in all respects.

It may be found convenient to have several of these adapters on hand to check coaxial cables with various types of fittings. If many checks are to be made, it may be advantageous to build a panel with a variety of adapters permanently fastened in place. (See fig. 2.)



FIGURE 2.—Several of the adapters are shown at the bottom, and above is a panel for mounting the adapters where they are used often.

The Bureau suggests one caution in the use of these adapters: *It is imperative that the adapters have no leaks or short themselves. Otherwise, a satisfactory cable might be wrongly diagnosed as being faulty. These adapters should be regularly checked with the megger (with no fitting inserted) to insure their reliability.* 1/1/49. ←

## PAINTING OF ANTENNAE

In the past, numerous questions and suggestions have been received by the Bureau concerning the color and type of paint to be used in painting and repainting shipboard antennae.

Antenna framework and dipoles should be inspected quarterly, and those installed directly aft of the stack should be inspected monthly. The gasses and temperature in the vicinity of the stacks tend to dry out and crack the paint, which accelerates corrosion.

When paint has started to crack or peel, and there is an indication of rust on the dipoles or framework of antennae, immediate action should be taken to clean the entire surrounding surface of old paint, soot, and rust, etc. The clean surface should then be repainted with two coats of JAN-P-735 zinc-chromate primer, stock No. 52-P-20630-2 (1 gallon) or 52-P-20635-2 (5 gallons), and with not less than two coats of number 27 outside haze-gray paint (Spec. MIL-P-15130, which supersedes 52-P-45a), stock No. 52-P-961 (5 gallons).

Brass dipoles need not be coated with the zinc-chromate primer. Under no circumstances should metallic paints be used.

Forces afloat, Navy yards and repair activities should use only the paints described above in repainting antennae. 4/1/51

SUBSTITUTE MATERIAL FOR  
TRANSMITTER ANTENNA TRUNKS

The substitution of aluminum for copper-clad steel in the construction of shipboard radio transmitter antenna trunks is permissible when the latter is not readily available. Authority for this was carried in Bureau of Ships multi-address letter serial U-982-2107 dated 9 June 1948. Excerpts from this letter are reprinted below:

"The current general requirements for Radio Antenna Systems, Bureau of Ships Specification RE 66A 430B, specify that transmitter antenna trunks shall be fabricated from steel having a minimum thickness of 0.094 inches and having a copper-nickel or copper plating of 0.008 inches minimum thickness (two sides or inside only). A number of activities have reported difficulty in procuring this material (copper-clad steel).

In the future, when the above copper-clad steel is not readily available, it will be satisfactory to substitute aluminum for use in fabricating radio transmitter antenna trunks. The aluminum should be 61 ST 6 in accordance with Navy Specification 47 A 12, condition T, and shall have a minimum thickness of 0.125 inches. The inside and outside of the fabricated trunks shall be treated with a zinc chromate primer, the outside to be painted as required." 7/1/51