

# INSTRUCTION BOOK

# LINEAR POWER AMPLIFIER 204F-1

520 5867 00

1 JULY 1959

1st REVISION, 1 OCTOBER 1959

© **COLLINS RADIO COMPANY**  
1959

**CEDAR RAPIDS, IOWA, U.S.A.**

Texas Division

PRINTED IN THE UNITED STATES OF AMERICA



## TABLE OF CONTENTS

Section		Page
I	GENERAL DESCRIPTION . . . . .	1
1.1	Purpose of Instruction Book . . . . .	1
1.2	Purpose of Equipment . . . . .	1
1.3	Equipment Supplied. . . . .	1
1.4	Equipment Required But Not Supplied . . . . .	1
1.5	Physical Description . . . . .	1
1.6	Electrical Characteristics. . . . .	3
1.7	Optional Features . . . . .	3
II	INSTALLATION . . . . .	3
2.1	General . . . . .	3
2.2	Unpacking and Inspecting the Equipment. . . . .	4
2.3	Installation . . . . .	4
2.3.1	Location . . . . .	4
2.3.2	Cabinet Installations . . . . .	4
2.3.3	Primary Power Connection . . . . .	5
2.3.4	Installation of Components Removed For Shipping . . . . .	6
2.3.5	Compensation For Line Voltage . . . . .	6
2.3.6	Installation of Tubes . . . . .	7
2.3.7	Signal and TGC Connections . . . . .	7
2.3.8	Power Control Connections . . . . .	9
2.3.9	Visual Inspection and Mechanical Checks . . . . .	10
2.4	Initial Tests and Adjustments. . . . .	10
2.4.1	Equipment Set Up . . . . .	11

252

TABLE OF CONTENTS (Cont)

Section		Page
2.4.2	Power Control Circuits. . . . .	12
2.4.3	Power Control and Filament Circuits . . . . .	12
2.4.4	Bias, Screen, and Plate Supply Circuits. . . . .	13
2.4.5	Multimeter Calibration. . . . .	14
2.4.6	Static Current Checks . . . . .	16
2.4.7	Thermal Overload Circuit . . . . .	16
2.4.8	R-F Amplifier Circuits. . . . .	17
2.4.9	R-F Voltmeter Calibration. . . . .	18
2.4.10	Plate Overload Circuit . . . . .	19
2.4.11	TGC Circuit . . . . .	19
2.4.12	Power Amplifier Neutralization . . . . .	20
2.4.13	Driver Amplifier Neutralization . . . . .	21
2.4.14	Preparation for Normal Operation . . . . .	22
III	OPERATION . . . . .	23
3.1	General . . . . .	23
3.2	Locations and Functions of Adjustments, Controls, and Indicators .	23
3.2.1	Power Supply Circuits . . . . .	23
3.2.2	Radio Frequency Amplifier Circuits . . . . .	25
3.3	Local Operation. . . . .	25
3.3.1	Pre-Operation Procedure . . . . .	26
3.4	Tuning Procedure . . . . .	27
3.4.1	Channel A Tuning Procedure . . . . .	27
3.4.2	Channel B Tuning Procedure . . . . .	29
3.5	Local Operation Starting Procedure . . . . .	31
3.6	Local Operation Stopping Procedure. . . . .	32
3.7	Emergency Shut-Down Procedure . . . . .	32
3.8	Operation While Performing Maintenance . . . . .	32
3.9	Remote Operation . . . . .	32
3.10	Operation With Optional Features . . . . .	32
IV	PRINCIPLES OF OPERATION . . . . .	33
4.1	General . . . . .	33
4.2	Power Supply Circuits . . . . .	33
4.2.1	Power Control Circuits. . . . .	33
4.2.2	Filament Circuits . . . . .	36
4.2.3	Bias, Screen, and Plate Supply Circuits. . . . .	36
4.3	Radio Frequency Amplifier Circuits. . . . .	37
4.3.1	Input Amplifier Stage . . . . .	38
4.3.2	Driver Amplifier Stage. . . . .	38
4.3.3	Power Amplifier Stage . . . . .	39
4.3.4	Output Network . . . . .	39
4.4	Transmitter Gain Control Circuit . . . . .	40
4.5	Metering Circuits . . . . .	40
4.6	Channel Switching Circuit . . . . .	41
4.6.1	Local Operation with Internal 120 V A-c. . . . .	41
4.6.2	Remote Operation . . . . .	42
4.7	Keying Relay Circuit . . . . .	42
4.7.1	Local Operation . . . . .	42
4.7.2	Remote Operation . . . . .	42

275

TABLE OF CONTENTS (Cont)

Section		Page
V	MAINTENANCE . . . . .	42
	5.1 General . . . . .	42
	5.2 Test Equipment . . . . .	43
	5.3 Preventive Maintenance . . . . .	43
	5.3.1 Daily Inspection - Power Not Applied. . . . .	43
	5.3.2 Weekly Inspection - Power Not Applied . . . . .	44
	5.3.3 Monthly Inspection - Power Not Applied . . . . .	44
	5.3.4 Daily Inspection - Power Applied . . . . .	44
	5.3.5 Weekly Inspection - Power Applied . . . . .	45
	5.3.6 Monthly Inspection - Power Applied . . . . .	47
	5.3.7 Lubrication . . . . .	55
	5.3.8 Filter Cleaning Procedure . . . . .	55
	5.4 Corrective Maintenance . . . . .	55
	5.4.1 Fault Isolation . . . . .	55
	5.4.2 Component Replacement . . . . .	55
VI	PARTS LIST . . . . .	59
VII	ILLUSTRATIONS . . . . .	71/72

LIST OF ILLUSTRATIONS

Figure		Page
1-1	Linear Power Amplifier 204F-1 . . . . .	iv
1-2	Linear Power Amplifier 204F-1, Cabinet Doors Open. . . . .	2
2-1	Linear Power Amplifier 204F-1, Mounting and Outline Dimensions. . . . .	5
2-2	Power and Power Control Transformer Connections . . . . .	8
2-3	Filament Transformer T4, Terminal Location . . . . .	15
3-1	Linear Power Amplifier 204F-1, Operating Controls . . . . .	24
6-1	Grid Box, Parts Identification . . . . .	59
6-2	Grid Compartment, Parts Identification . . . . .	60
6-3	Input-Output Compartment, Parts Identification . . . . .	61
6-4	Power Supply Compartment, Parts Identification . . . . .	62
6-5	Power Supply Compartment, Parts Identification . . . . .	63
6-6	R-F Compartment, Parts Identification . . . . .	64
7-1	Linear Power Amplifier 204F-1, Power Supply Circuits, Schematic Diagram . . . . .	71/72
7-2	Linear Power Amplifier 204F-1, R-F Amplifier Circuits . . . . .	73/74
7-3	Linear Power Amplifier 204F-1, Typical Remote Control Circuit Connections . . . . .	75
7-4	Typical Remote Control Circuit Connection, One-Shot Recycle Feature Installed . . . . .	76
7-5	Linear Power Amplifier 204F-1, R-F Amplifier Circuits With Dual Input-Output Feature . . . . .	77/78

LIST OF TABLES

Table		Page
2-1	Typical Shipping Data . . . . .	4
3-1	Padding Capacity Selection . . . . .	28
3-2	Padding Capacity Selection . . . . .	30
5-1	Linear Power Amplifier 204F-1, Fault Isolation Test Procedure . . . . .	56

**SECTION I**  
**General Description**

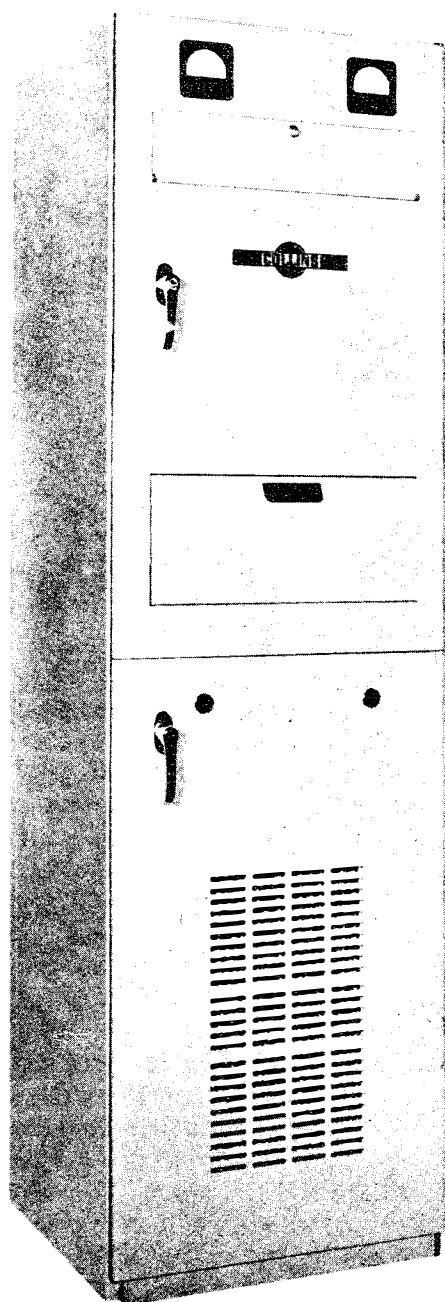

**Figure 1-1. Linear Power Amplifier 204F-1**

SECTION I  
GENERAL DESCRIPTION

1.1 PURPOSE OF INSTRUCTION BOOK.

This instruction book contains instructions for the installation, operation, and maintenance of Linear Power Amplifier 204F-1.

1.2 PURPOSE OF EQUIPMENT.

Linear Power Amplifier 204F-1 is a three-stage, linear power amplifier that is designed to amplify low-power radio frequency signals from an associated exciter unit to a level suitable for transmission from an antenna. The 204F-1 is primarily intended for single sideband operation, but can be used with any type of input signal that does not exceed its bandwidth and power capabilities. The amplifier may be switched to either of two channels, and either channel may be tuned to any frequency between 2 and 30 megacycles. The 204F-1 is capable of delivering either 2.5 kilowatts peak envelope or 2.5 kilowatts average power continuously. It can be operated locally or remotely.

1.3 EQUIPMENT SUPPLIED.

Linear Power Amplifier 204F-1 is contained in a single cabinet, which is shown in figure 1-1 and described in paragraph 1.5.

1.4 EQUIPMENT REQUIRED BUT NOT SUPPLIED.

Linear Power Amplifier 204F-1 is not intended for use as a single unit, but is intended for use as one portion of a complete system. The quantity and type of equipment required but not supplied will be determined by the individual installation.

1.5 PHYSICAL DESCRIPTION.

All components of Linear Power Amplifier 204F-1 are enclosed in an aluminum cabinet that is painted with a light-grey enamel. This cabinet is self supporting, and is 20 inches wide, 20 inches deep, and 70 inches high. With all components installed, the unit weighs approximately 600 pounds. Upper and lower cabinet doors form the front surface of the cabinet and provide access to all interior areas of the cabinet. Cooling air is drawn into the equipment by an internal blower unit through a filter located on the lower door. Heated air is exhausted through an opening in the top of the cabinet. All power and signal connections are made through the top of the cabinet.

The upper cabinet door provides a mounting surface for two meters and access to the upper half of the cabinet interior. Two hinged access panels in the upper door provide access to all operating controls. The upper half of the cabinet is divided into three compartments (see figure 1-2). The uppermost compartment is referred to as the input-output compartment. All power and signal functions enter and leave the cabinet through this compartment. The next compartment down from the top of the cabinet is referred to as the r-f compartment. This compartment encloses the power amplifier tubes and all the components associated with the anode circuits of these tubes. A small panel located along the upper edge of the compartment provides a mounting surface for the tuning controls associated with the r-f output circuits. These controls are accessible through the upper hinged panel in the upper cabinet door.

The lowest of the three compartments that comprise the upper half of the cabinet is referred to as the grid compartment. All of the components associated with the input and driver amplifier stages, and those associated with the filament, cathode, control grid and screen grid elements of the power amplifier tubes, are located in this compartment. The majority of the components are mounted in

**SECTION I**  
**General Description**

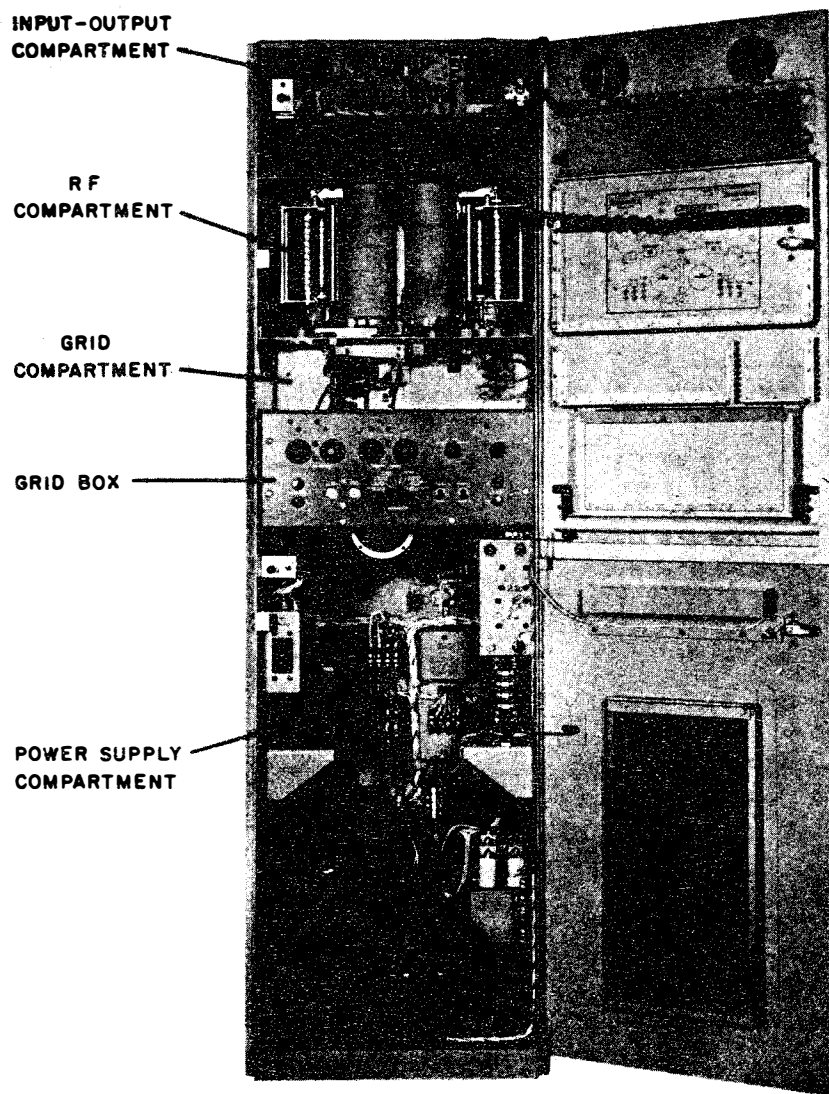

**Figure 1-2. Linear Power Amplifier 204F-1, Cabinet Doors Open**

a rectangular enclosure that has been named grid box. This enclosure, which is removable for servicing, is divided into two parts. The input amplifier and both driver amplifier tubes are mounted on the partition that divides the enclosure. All components in the anode circuit of the driver amplifier stage and the filament, cathode, control grid, and screen grid circuits of the power amplifier stage are in the area to the right of this divider wall. (Filament transformer T4 is mounted on the cabinet wall and is not removed from the cabinet with the grid box). The components of the input amplifier stage and the filament, cathode, control grid, and screen grid circuits of the driver amplifier stage are located to the left of the divider wall. The tuning controls associated with the input amplifier and driver amplifier stages are mounted on the front surface of the grid box, and are accessible through the opening normally covered by the lower hinged panel in the upper cabinet door.

The lower cabinet door provides access to the power supply compartment which occupies the lower half of the cabinet. All components associated with the transformation of primary power to the voltages necessary to operate the circuits of the linear power amplifier are located in this compartment. Operating controls for the power supply circuits are mounted on a small panel at the top of the power supply compartment. This panel is hidden from view when the grid box is in place, but the operating controls are brought out through openings in the front surface of the grid box.

### 1.6 ELECTRICAL CHARACTERISTICS.

FREQUENCY RANGE: 2 to 30 megacycles.

TUNING: Manual adjustment to frequency by front panel controls, tap changes, and capacitor changes.

TYPES OF EMISSION: Any type not exceeding bandwidth or power capabilities. Superior for SSB operation.

BANDWIDTH: At least 16 kilocycles wide at 1-db points.

POWER OUTPUT: 2.5 kilowatts peak envelope power or 2.5 kilowatts average power continuously.

INPUT IMPEDANCE: 50 ohms.

OUTPUT IMPEDANCE: 50 ohms.

EXCITATION REQUIRED: 0.1 watt nominal, 0.2 watt maximum, from external exciter.

SSB DISTORTION: At least 35 db signal-to-distortion ratio.

TUBE COMPLEMENT: One input amplifier (6CL6)  
Two driver amplifiers (6146)  
Two power amplifiers (4CX1000A)  
Two high voltage rectifiers (872A or 4B32)

POWER SOURCE: 200 to 250 volts, single phase, 50 to 60 cps, six kva capacity.

### 1.7 OPTIONAL FEATURES.

Linear Power Amplifier 204F-1 can be equipped with several features not normally supplied. One of these is a one-shot, recycle unit, which will automatically return the equipment to service if a temporary overload condition causes the power control circuits to remove normal operating voltages. Another is dual r-f input and dual r-f output circuits, which will allow the equipment to be alternately used in two separate systems. A third one is a wattmeter mounted on the upper door with a switch for reflected or forward power selection. If present, these features will be factory installed. Some mention of these optional features will be made in this instruction book.

## SECTION II

### INSTALLATION

#### 2.1 GENERAL.

Space and floor loading considerations are the primary factors in determining a location for the Linear Power Amplifier 204F-1. The equipment should be installed in a building or shelter to prevent direct exposure to the elements. The linear power amplifier is partially disassembled and the various components are either crated or boxed for shipping.

SECTION II  
Installation

2.2 UNPACKING AND INSPECTING THE EQUIPMENT.

The method and routing of shipments, and the number of amplifiers included per shipment, will determine the type of shipping containers used and the general contents of each box or crate. A typical method of shipment is given in table 2-1. Minor variations from this method should be expected. The number of boxes and crates received should always be checked against the shipping invoice. The crating and packing materials should be removed carefully, and the contents of each container carefully inspected for physical damage and breakage. Any claims for damage should be filed promptly with the transportation agency. If such claims are to be filed, all packing material must be retained. Screws and bolts required for assembly of parts, which have been removed for shipping purposes, are attached to the part, tied to the cabinet near where the part is to be installed or packed in a separate box as accessories.

CAUTION

Extreme care must be exercised when handling electron tubes.  
A sharp blow or impact may cause breakage of internal parts.

It is recommended that the heavier components, such as the cabinet, be uncrated as close as possible to the actual point of installation. This will facilitate handling and also reduce the possibility of damage.

TABLE 2-1. TYPICAL SHIPPING DATA

BOX NUMBER	CONTENTS	DIMENSIONS			WEIGHT
		LENGTH	WIDTH	HEIGHT	
1	Linear Power Amplifier 204F-1	25	26	80	800
2	Power Transformer T6	12	18	18	100
3	Filter Choke L22	9	12	12	50

2.3 INSTALLATION.

The installation of a 204F-1 can be accomplished as described in the following subparagraphs.

2.3.1 LOCATION.

The first thing to be accomplished is the choice of a suitable location for the equipment (see figure 2-1). Space and floor loading considerations are the primary factors involved. The linear power amplifier occupies only a small area, 20 inches in width and 20 inches in depth, but allowance must be made for access to the front of the equipment. This small area must be capable of supporting the equipment weight, which is approximately 600 pounds. All external connections are made through the top of the cabinet, which is 70 inches tall.

Cooling air is a secondary, but very important consideration. Cooling air is obtained from the room in which the equipment is installed and is drawn directly from the room through a filter located on the lower front door. The warmed air is exhausted through an opening in the top of the cabinet to a duct or directly into the room.

2.3.2 CABINET INSTALLATIONS.

The cabinet should be moved as close as possible to the selected installation site in its original shipping crate, and then the following steps taken.



- a. Place the cabinet in an upright position with the front of the cabinet facing in the same direction that it will face after installation. Carefully remove all of the shipping crate except the base.
- b. Slide the cabinet an inch or two so that the rear of the cabinet extends over the base of the shipping crate. Tilt the cabinet backward and slide the base out from under the cabinet. Set the cabinet in an upright position.
- c. Remove the panels, which are secured by machine screws, that cover the two rear corners of the cabinet. Inspect interconnection cabling for obvious signs of damage.
- d. Open both the upper and lower cabinet doors. If locked, unlock with the keys provided. Remove all packing and bracing material. Inspect cabinet interior for obvious signs of damage.
- e. Slide the cabinet into place, and open both doors.

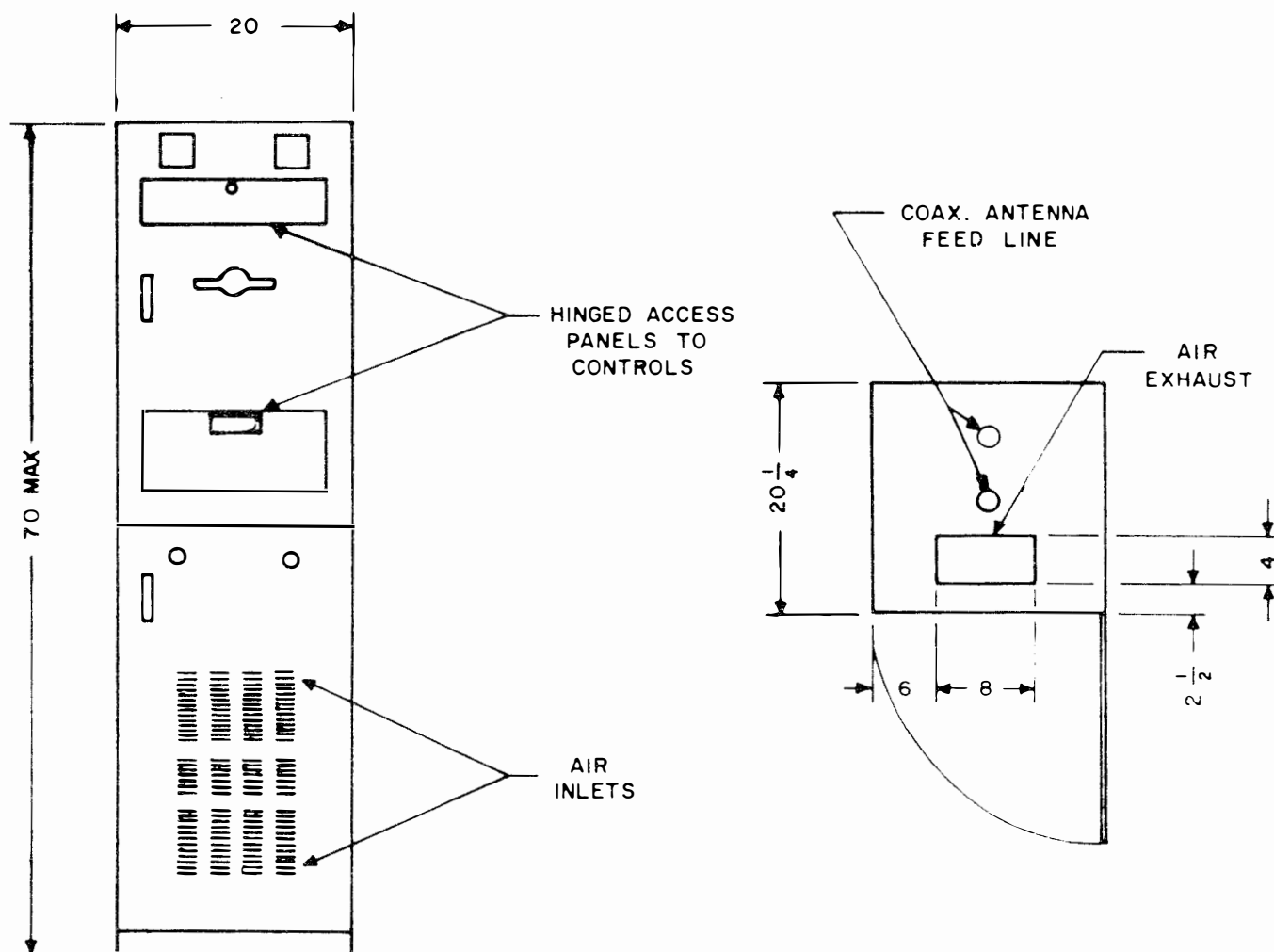

Figure 2-1. Linear Power Amplifier 204F-1, Mounting and Outline Dimensions

### 2.3.3 PRIMARY POWER CONNECTION.

The linear power amplifier requires a source of primary power that can provide up to six kilovolt-amperes at 200 to 250 volts, single-phase, 50 to 60 cycles-per-second. This power should be connected to the equipment through a double-pole, 30-ampere capacity, disconnect switch. The connection should be made as follows.

## SECTION II Installation

a. Mount the disconnect switch near the equipment and connect the line side to an adequate source of power.

### CAUTION

Do not install any fuses in the disconnect switch until after the equipment installation has been completed.

b. Connect the switch and the cabinet with a one-inch conduit. Provision is made for connecting the conduit to the top of the cabinet just above terminal board TB2. Insert two number 6 AWG and one number 10 AWG rubber insulated wires through the conduit, through the input-output compartment, down one corner of the cabinet, and into the power supply compartment. Connect the load side terminals of the switch to terminal 2 and 3 of terminal board TB1, by means of the number 6 AWG conductors. Connect the number 10 AWG conductor to terminal 1 of TB1 and to the ground terminal of the switch.

#### 2.3.4 INSTALLATION OF COMPONENTS REMOVED FOR SHIPPING.

Power transformer T6, filter choke L22 and one of the two high voltage shorting sticks were removed from the cabinet during shipment. Proceed to install these items in the cabinet as follows:

- a. Remove transformer T6 and filter choke L22 from their shipping containers.
- b. Open the lower cabinet door. Slide transformer T6 into the rear left corner of the cabinet with the terminals on the transformer facing the right cabinet wall.
- c. Position the transformer over the mounting holes provided in the base of the cabinet. Secure the transformer to the base of the cabinet with the four 5/16 - 18 NC machine screws furnished.
- d. Connect equipment wiring to the terminals of T6.

### NOTE

All wires and terminals from which wires were removed are tagged with corresponding numbers. Match numbers and terminals.

- e. Slide filter choke L22 into the front left corner of the cabinet with the terminals of the unit facing the front of the cabinet.
- f. Position the choke over the four mounting holes provided, and secure the choke to the cabinet base with the four 1/4-20 NC machine screws furnished. Connect wiring to terminals of L22.
- g. Mount the high voltage shorting stick in the clips furnished on T6.
- h. Connect the wire from the shorting stick to cabinet ground.

#### 2.3.5 COMPENSATION FOR LINE VOLTAGE.

The primary power source voltage may be anywhere in the range between 200 and 250 volts. By making proper connections within the equipment, any voltage within the 200 to 250 volt range can be transformed to provide the correct voltages required for operation of the linear power amplifier. These connections are made as follows:

- a. Determine the level of voltage available at the line side of the disconnect switch.
- b. Connect the movable primary power lead (this is a white wire with a brown tracer) to the appropriate terminal of T1. Determine the correct terminal from the table shown in figure 2-2.

c. Connect the movable primary power lead (this is the white wire with the orange tracer) to the appropriate terminal of T6. Determine the appropriate terminal of T6 from the table shown in figure 2-2.

NOTE

Transformer T1 and T6 are both located in the power supply compartment. T1 is mounted on the shelf that is secured to the right cabinet wall. T6 is located in the lower left corner of the power supply compartment. Terminal locations for both T1 and T6 are shown in figure 2-2.

2.3.6 INSTALLATION OF TUBES.

Do not install any tubes in the linear power amplifier until directed to do so.

2.3.7 SIGNAL AND TGC CONNECTIONS.

The linear power amplifier is connected to the associated exciter unit by either three or four coaxial cables. Three cables are required if the 204F-1 is furnished with a single r-f input, and four cables are required if the 204F-1 is furnished with the dual r-f input feature. In either case, two of these cables couple the output of the transmitter gain control (TGC) to the associated exciter. One cable provides a gain control signal to the portion of the exciter that is furnishing the channel A signal, and the other cable is connected to the portion of the exciter that is producing the channel B signal. When the single r-f input feature is furnished, the third cable connects either the channel A or channel B signal from the exciter to the 204F-1. When the dual r-f input feature is installed, the channel A and channel B input signals are coupled by separate cables.

Separate provision is made for connecting the r-f signal output to the associated antenna. The 204F-1 may be equipped with either single or dual output facilities. If the single output feature is furnished, a single length of semi-rigid transmission line may be used to connect the output of the 204F-1 to the associated antenna. If the dual output feature is installed, two lengths of semi-rigid transmission line are required.

The input signal, TGC, and output signal connections are made as described in the following steps:

a. Prepare three lengths of RG-58/U coaxial cable, which will reach from the linear power amplifier to the associated exciter unit, with one end of each terminated in a UG-88C/U or UG-260B/U connector. Run all three cables through the 3/4-inch conduit. Connect the cables to the three r-f connectors that are located to the right and on the same mounting bracket as terminal boards TB2 and TB14. The second end of each cable should be fitted with the type of connector that will mate with the connectors on the associated exciter unit. The cable that mates with the connector which is labeled J1 should be connected to the signal output of the associated exciter unit. The other cables, which are connected to J2 and J3, should be connected to the channel A and channel B transmitter gain control (TGC) input terminals, respectively, of the exciter.

NOTE

If the dual input feature is incorporated in the equipment, prepare four lengths of RG-58C/U coaxial cable. Two cables must be long enough to reach the source of channel A r-f input signals. The other two cables must reach the source of channel B r-f input signals. Terminate one end of all four cables in UG-88C/U connectors. Run all four cables through the 3/4-inch conduit. Connect the cables to

SECTION II  
Installation

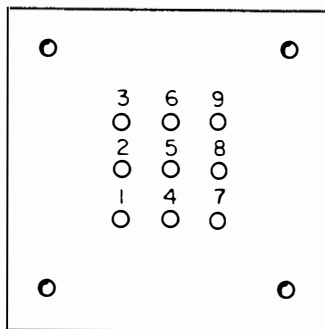

(A) POWER CONTROL TRANSFORMER T1

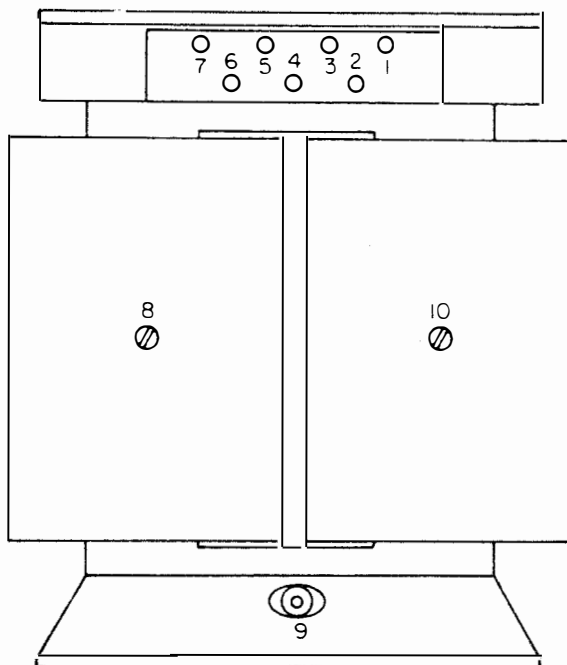

(B) POWER TRANSFORMER T6

LINE VOLTAGE	APPLY BETWEEN TERMINALS	
200	1	2
210	1	3
220	1	4
230	1	5
240	1	6
250	1	7

Figure 2-2. Power and Power Control Transformer Connections

J2, J3, J9 and J10. The other end of the cables connected to J2 and J9 should be fitted with the proper type connectors and connected to the TGC and signal output terminals, respectively, of the channel A r-f signal source. The other end of the cables connected to J3 and J10 should be fitted with the proper type connectors, and connected to the TGC and signal output terminals, respectively, of the channel B r-f signal source.

b. Remove the two plates that cover the rear portion of the top of the cabinet. Remove any packing material that was inserted to prevent shipping damage, and inspect the components in the input-output compartment for obvious signs of damage. Remove the tape covering the top of the directional coupler unit. Connect the directional coupler to the associated antenna circuits with RG-17/U, semi-rigid transmission line. Replace and secure the top cabinet cover plates.

NOTE

If the dual output feature is incorporated in the equipment, two directional couplers are furnished.

2.3.8 POWER CONTROL CONNECTIONS.

The linear power amplifier may be connected for either local or remote operation. If only local operation is desired, certain terminals of TB2 must be interconnected. If remote operation is desired, certain terminals of TB2 and TB14 must be connected to operating controls and indicators that are located at the remote location. The necessary wiring to the remote location should enter the cabinet through the same 3/4-inch conduit that is used to connect the input signal and TGC circuits to the associated exciter. When the 204F-1 is to be operated from a remote location, an optional feature which provides automatic reapplication of power if a temporary overload condition causes the equipment protective devices to function, may be installed in the cabinet. If this device is installed, the remote control circuits are connected in a slightly different manner. The connections that must be made for each of the three possible conditions are explained in the following subparagraphs.

2.3.8.1 LOCAL OPERATION ONLY. - If local operation only is desired, certain terminals of TB2 must be interconnected. Proceed as follows:

- a. Connect terminals 1 and 2 of TB2.
- b. Jumper terminals 3, 9 and 11 of TB2 with insulated wire.

NOTE

Terminals 9 and 11 may be connected through the contacts of a relay that is controlled by the key line of the exciter.

2.3.8.2 REMOTE OPERATION WITHOUT AUTOMATIC RECYCLE. - If it is desired to operate the 204F-1 from a remote location, the controls and indicators at the remote site must be connected to the terminals of TB2 and TB14. The exact manner in which these circuits are connected will be determined by the individual installation. A typical method of making these connections is shown in figure 7-3 and may be used as a guide.

2.3.8.3 REMOTE OPERATION WITH AUTOMATIC RECYCLE. - If the one-shot, recycle feature is installed, the remote control circuit connections to TB2 and TB14 are slightly different than those made when this feature is not installed. A typical method of making these connections and a schematic of the recycle unit are shown in figure 7-4. This diagram may be used as a guide in making the connections for a given installation.

SECTION II  
Installation

2.3.9 VISUAL INSPECTION AND MECHANICAL CHECKS.

The linear power amplifier should be visually inspected and certain physical checks performed after all installation effort is completed. Proceed as follows:

- a. Open the upper and lower cabinet doors.
- b. Remove the grid box from the cabinet.

NOTE

The grid box is removed from the cabinet by removing the knob from the MULTIMETER switch, loosening six twist-lock screws, pulling the grid box slightly forward, disconnecting coaxial connector P7 from J7, and pulling the grid box straight forward out of the cabinet.

- c. Visually inspect the circuitry mounted in the grid box, and check that the input amplifier and driver amplifier tubes are not installed. Return grid box to cabinet.
- d. Visually inspect all wiring to terminal boards and components. Check all connections for tightness.
- e. Manually operate all relays. Check for smoothness of operation.
- f. Manually operate the upper and lower door interlocks. They should operate freely without binding.
- g. Manipulate all operating controls and switches to ensure tightness of knobs and freedom from binding.
- h. Manually operate the PA PLATE circuit breaker to ensure freedom of operation.
- i. Check to see that both high voltage shorting sticks are in their mounting clips. One is mounted to the rear surface of the upper door, and the other is mounted on T6 in the power supply compartment. Check that the wire of each shorting stick is connected to a good cabinet ground.
- j. Check that all active fuse holders contain a fuse of the proper value.
- k. Check that the power amplifier, TGC, and high voltage rectifier tubes are not installed in their sockets.
- l. Check that the power amplifier air chimneys are in place.
- m. Remove all foreign material from interior of cabinet.
- n. Close both the upper and lower cabinet doors.
- o. Replace the two panels that cover the rear corners of the cabinet.

2.4 INITIAL TESTS AND ADJUSTMENTS.

After the linear power amplifier has been properly installed as described in paragraph 2.3, the initial test and adjustments described in the following paragraphs should be performed.

### 2.4.1 EQUIPMENT SET UP.

In order to properly check out the linear power amplifier, the following steps should be performed before any testing is attempted.

- a. Open the upper and lower cabinet doors.
- b. Remove the grid box from the cabinet and place in safe location.

#### NOTE

The grid box is removed from the cabinet by removing the knob from the MULTIMETER switch, loosening six twist-lock screws, pulling the grid box slightly forward, disconnecting coaxial connector P7 from J7, and pulling the grid box straight forward out of the cabinet.

- c. Cover the openings in the cabinet shelf, which separates the r-f and grid compartments, through which the power amplifier tubes normally pass. Leave the upper half of the PA air chimneys inserted in their appropriate positions.

#### NOTE

Cover these openings with masking tape or some other material that will not be moved by air pressure.

- d. Disconnect the r-f signal input. This can be accomplished by disconnecting the cable at J1, or cables at J9 and J10, from the associated exciter unit.
- e. Disconnect all control circuit wiring from terminal boards TB2 and TB14, tagging each lead as it is removed.

#### WARNING

If the 204F-1 is connected for remote control operation, operating voltages may be present on the leads to TB2 and TB14.

- f. Connect terminals 1 and 2 of TB2 together.
- g. Connect terminals 3 and 9 of TB2 with insulated wire.
- h. Turn the LEFT PA BIAS and RIGHT PA BIAS adjustments fully counterclockwise.
- i. Determine that primary power is applied to the proper terminals of transformers T1 and T6 as described in paragraph 2.3.5.
- j. Place the PA PLATE circuit breaker in the OFF position.
- k. Place the LOCAL-REMOTE switch in the LOCAL position.
- l. Place the CHANNEL A-CHANNEL B switch in the CHANNEL A position.
- m. Place the MULTIMETER switch in the PA PLATE VOLTS position.
- n. Close both the upper and lower cabinet doors.

## SECTION II

### Installation

o. Insert two 30-ampere fuses in the external disconnect switch, and place the switch in the ON position.

#### 2.4.2 POWER CONTROL CIRCUITS.

After the steps of paragraph 2.4.1 have been performed, proceed to check the power control circuits of the linear power amplifier as follows:

- a. Depress the FILAMENTS ON pushbutton, and observe that the FILAMENTS indicator lights.
- b. Depress the FILAMENTS OFF pushbutton switch, and observe that the FILAMENTS indicator is extinguished.
- c. Open the lower cabinet door, depress the FILAMENTS ON switch, and observe that the FILAMENTS indicator does not light.
- d. Close the lower cabinet door, and open the upper cabinet door. Depress the FILAMENTS ON pushbutton. Observe that the FILAMENTS indicator does not light.
- e. Remove one of the power amplifier tube air chimneys, close the upper cabinet door, and depress the FILAMENTS ON switch. Observe that the FILAMENTS indicator does not light.
- f. Open the upper cabinet door. Replace the air chimney that was removed in step e, and then remove the other air chimney. Close the upper cabinet door, and depress the FILAMENTS ON switch. Observe that the FILAMENTS indicator does not light.
- g. Open the upper cabinet door, and replace the air chimney removed in step f.
- h. Close the upper cabinet door. Depress the PLATE ON pushbutton switch. Observe that the FILAMENTS indicator lights immediately. Hold the PLATE ON pushbutton in the depressed position, and observe that the PLATE indicator lights after approximately three minutes. Release the PLATE ON button, and observe that the PLATE indicator is extinguished.
- i. Depress the FILAMENTS OFF switch, and observe that the FILAMENTS indicator is extinguished.
- j. Place the external disconnect switch in the OFF position.

#### 2.4.3 POWER CONTROL AND FILAMENT CIRCUITS.

After the power control circuits have been partially tested as described in paragraph 2.4.2, proceed to test the power control and filament circuits as follows:

- a. Observe that the external disconnect switch is in the OFF position. Then open the lower cabinet door.
- b. Insert type 872A or 4B32 tubes in the sockets labeled XV6 and XV7, which are located on a shelf that is fastened to the left cabinet wall in the power supply compartment. Place the anode caps firmly in place on the tubes.
- c. Connect a Weston Model 433 (0 to 15 and 0 to 30-volt scales) a-c voltmeter, or equivalent, across the filament terminals of either XV6 or XV7. Connect the meter for operation on the 0 to 15 volt scale.
- d. Block the lower door interlock in its closed position, and leave the lower cabinet door open.



e. Place the external disconnect switch in the ON position. Depress the FILAMENTS ON switch. Observe that the voltmeter is indicating  $5 \pm 0.25$  volts. Allow equipment to operate with filaments on ONLY for one-half hour. This allows the mercury in the high voltage rectifier tubes to distribute properly.

NOTE

If the filament voltage is not within the specified limits: depress the FILAMENTS OFF switch, place the external disconnect switch in the OFF position, and change taps on transformer T1 as described in paragraph 2.3.5. Then repeat step e.

f. Place the PA PLATE circuit breaker in the ON position, and depress the PLATE ON switch.

g. After the PLATE indicator lights, observe that the two high voltage rectifier tubes are glowing with uniform brightness and color.

h. Depress the PLATE OFF switch, and observe that the PLATE indicator is extinguished.

i. Depress the FILAMENTS OFF switch, and observe that the FILAMENTS indicator is extinguished. Place the external disconnect switch in the OFF position. Disconnect the voltmeter from the rectifier tube socket.

2.4.4 BIAS, SCREEN, AND PLATE SUPPLY CIRCUITS.

After it has been determined that the power control and filament supply circuits are functioning properly as described in paragraph 2.4.3, proceed to test the bias, screen, and plate supply circuits as follows:

a. Open the upper cabinet door. Connect a Triplett Model 630 voltohmmeter, or equivalent, between feed thru capacitor C55 and ground. Set the meter to read a negative voltage of approximately 310 volts.

NOTE

The meter leads should be connected to the end of C55 that protrudes into the grid compartment. The meter should be positioned so that the meter face is visible with the upper cabinet door closed, but with the lower access panel open, or the meter leads should be brought out through the access panel opening to the meter outside the cabinet.

b. Close the upper cabinet door. Place the external disconnect switch in the ON position, and depress the PLATE ON switch. After the PLATE indicator is illuminated, observe that the meter is indicating  $-310 \pm 10$  volts.

c. Set the MULTIMETER switch in the PA PLATE VOLTS position, and observe that the MULTIMETER is indicating  $3200 \pm 200$  volts.

d. Depress the FILAMENTS OFF switch. Place the external disconnect switch in the OFF position. Open the upper cabinet door.

## SECTION II

### Installation

e. Disconnect the meter from C55 and connect it to feed through capacitor C49. Set the meter to read a negative voltage of greater than 400 volts. Close the upper cabinet door.

f. Place the external disconnect switch in the ON position, and depress the PLATE ON push-button switch. After the PLATE indicator lights, observe that the voltmeter is indicating approximately -400 volts.

g. Turn the LEFT PA BIAS adjustment fully clockwise, and observe that the meter indication decreases to approximately -350 volts. Turn the LEFT PA BIAS adjustment fully counterclockwise.

#### NOTE

The location of the LEFT PA BIAS adjustment can be determined by referring to the front panel of the grid box.

h. Depress the FILAMENTS OFF switch, and then place the external disconnect switch in the OFF position. Open the upper cabinet door.

i. Disconnect the voltmeter and remove it from the cabinet.

#### 2.4.5 MULTIMETER CALIBRATION.

Calibration of the MULTIMETER should be checked with all tubes installed in the grid box, and with the grid box installed in the cabinet. If the procedures of paragraphs 2.4.1 through 2.4.4 have been accomplished, proceed to check the meter calibration as follows.

a. Observe that the external disconnect switch is in the OFF position, and that the upper cabinet door is open.

b. Open the lower cabinet door, and block the lower door interlock switch in the closed position.

c. Remove the two access hole cover plates that are located on the shelf that separates the grid compartment and power supply compartment.

d. Connect a Weston Model 433 (0 to 15 and 0 to 30-volt scales) a-c voltmeter, or equivalent, between terminals 7 and 8 of transformer T4 (see figure 2-3). Connect the meter for operation on the 0 to 15-volt scale.

#### NOTE

The meter should be located outside of the cabinet. The meter leads run down through one of the access holes, through the power supply compartment, and out of the cabinet.

e. Insert one type 6CL6 and two type 6146 tubes in the tube sockets of the grid box. Remove the tube shield that is mounted to the socket labeled XV1, and insert the 6CL6 tube. Replace the tube shield. Insert the two 6146 tubes in the sockets labeled XV2 and XV3. Mount suppressor assembly Z2 on the plate caps of XV2 and XV3.

f. Place the grid box in the cabinet. Mate coaxial connector P7 to J7, and secure the six twist-lock screws. Replace the knob on the MULTIMETER switch.

g. Place the MULTIMETER switch in the PA FIL VOLTS position. Place the DR TUNE-PA TUNE-OPERATE switch in the DR TUNE position. Close the upper cabinet door.

h. Place the external disconnect switch in the ON position, and depress the FILAMENTS ON switch. Observe that both the meter connected to transformer T4 and the MULTIMETER are indicating some voltage.

i. Turn the PA FILAMENT control clockwise until the meter connected to transformer T4 is indicating exactly six volts. Observe that the Multimeter is indicating exactly six volts.

NOTE

If the MULTIMETER does not indicate correctly, adjust R45, which is located on a mounting panel in the upper left corner of the power supply compartment, until it indicates exactly six volts.

j. Depress the FILAMENTS OFF switch, and place the external disconnect switch in the OFF position. Open the upper cabinet door and remove meter.

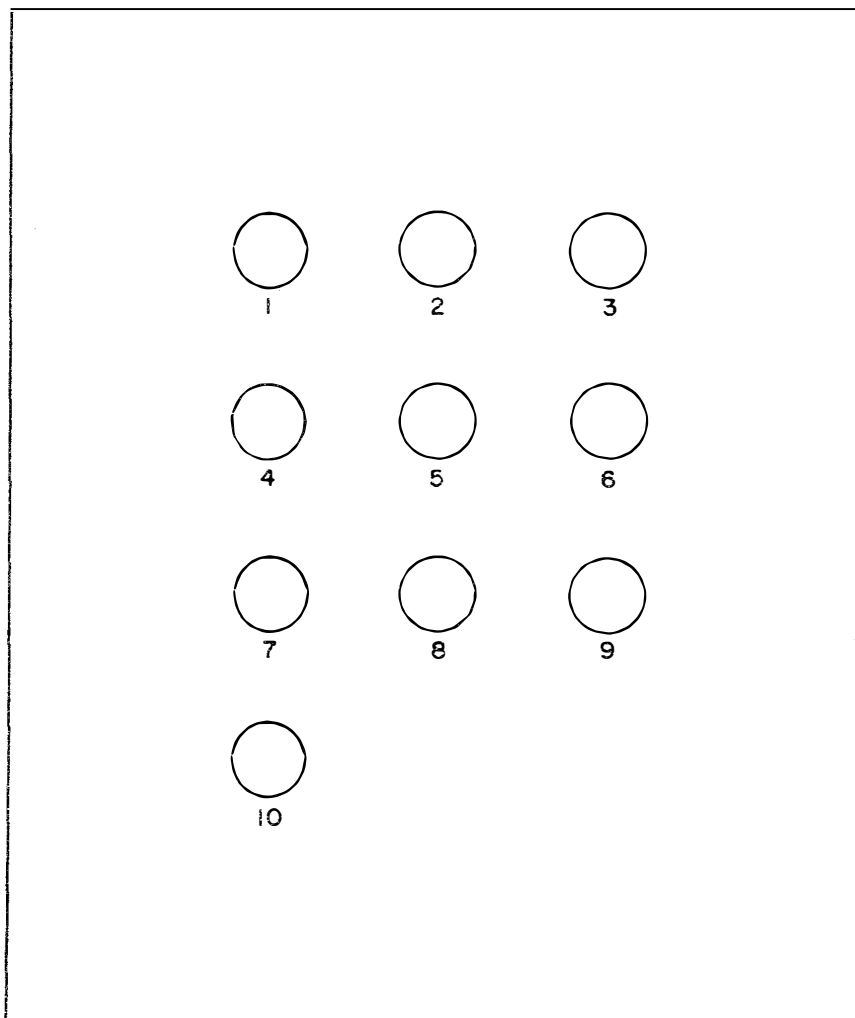

Figure 2-3. Filament Transformer T4, Terminal Location

## SECTION II Installation

### 2.4.6 STATIC CURRENT CHECKS.

After the calibration of the MULTIMETER is completed as described in paragraph 2.4.5, proceed to check the static currents of the r-f amplifier stages as follows:

- a. Observe that the external disconnect switch is in the OFF position, and that the upper cabinet door is open.
- b. Remove the covering from the openings in the shelf that separates the r-f and grid compartments. Install two type 4CX1000A tubes in the sockets provided.

#### NOTE

It will be necessary to slide the air chimneys upward in order to fit the tubes in their sockets. After the tubes are installed, slide the air chimneys downward and fit to the tube.

- c. Connect a jumper between terminals 9 and 11 of TB2.
- d. Place the MULTIMETER switch in the PA SCREEN position, and the DR TUNE-PA TUNE-OPERATE switch in the OPERATE position.
- e. Close the upper cabinet door. Place the external disconnect switch in the ON position, and depress the PLATE ON switch. After the PLATE indicator lights, observe that the MULTIMETER is indicating zero milliamperes.
- f. Place the MULTIMETER switch in the DRIVER PLATE position, and observe that the MULTIMETER is indicating approximately 120 milliamperes.
- g. Place the MULTIMETER switch in the LT PA CATH position. Turn the LEFT PA BIAS adjustment clockwise until the MULTIMETER is indicating 250 milliamperes.
- h. Place the MULTIMETER switch in the RT PA CATH position, and turn the RIGHT PA BIAS adjustment clockwise until the MULTIMETER is indicating 250 milliamperes. Observe that the PLATE CURRENT meter is indicating 0.5 amperes.
- i. Depress the FILAMENTS OFF switch, and then place the external disconnect switch in the OFF position.

### 2.4.7 THERMAL OVERLOAD CIRCUIT.

After the static current checks of paragraph 2.4.6 have been made, proceed to check the thermal overload circuit as follows:

- a. Observe that the external disconnect switch is in the OFF position.
- b. Remove the two plates that cover the rear portion of the top of the cabinet. Connect a Weston Model 433 (0 to 15 and 0 to 30-volt scales) a-c voltmeter, or equivalent, between terminals 1 and 2 on TB13. Connect the meter for operation on the 0 to 30-volt scale.

#### NOTE

The terminals of TB13 are not numbered. Terminal 1 is the terminal that has a white wire with brown and orange tracers. Terminal 2 is the terminal with a white wire with black and green tracers.

c. Place the external disconnect switch in the ON position, and depress the PLATE ON push-button. After the PLATE indicator is illuminated, set the OVERLOAD control for a reading of 23 volts on the meter. Allow the equipment to operate for 15 minutes.

d. Turn the RIGHT PA BIAS adjustment until the MULTIMETER is indicating 350 milliamperes. Place the MULTIMETER switch in the LT PA CATH position, and adjust the LEFT PA BIAS adjustment until the MULTIMETER is indicating 350 milliamperes. Within one minute, the thermal overload circuit will operate removing screen and plate voltage from V4 and V5. Operation of the overload circuit will be indicated by the PLATE indicator being extinguished.

NOTE

The setting of the OVERLOAD control is a function of ambient temperature. The adjustment for an indication of 23 volts applies only when the room temperature is 29 degrees C (84 degrees F).

e. Turn both the LEFT PA BIAS and RIGHT PA BIAS controls counterclockwise. Depress the FILAMENTS OFF switch, and place the external disconnect switch in the OFF position.

f. Disconnect the voltmeter from TB13, and replace the two plates on the rear portion of the top of the cabinet.

2.4.8 R-F AMPLIFIER CIRCUITS.

After the thermal overload circuit is checked as described in paragraph 2.4.7, check the r-f amplifier circuits as follows.

a. Observe that the external disconnect switch is in the OFF position, then open the upper cabinet door.

b. Reconnect the r-f signal input that was removed in step d. of paragraph 2.4.2. Determine that the associated exciter is not delivering a signal to the linear power amplifier.

c. Disconnect the r-f feedback signal at C4 in the grid box. Accomplish this by removing the end of C4 that is attached to a mounting post, and connecting this end of C4 to the grounding post provided.

d. Set the turn shorting device on L1, which is located in the left half of the grid box directly above the CHANNEL A INPUT AMP TUNING control, to short out all except two turns. Set the turn shorting device by lifting the support rod slightly and sliding the shorting contact.

e. Set the CHANNEL A INPUT AMP TUNING control to a dial setting of 17.

f. Set the turn shorting device on L6, which is located in the right half of the grid box directly above the CHANNEL A DRIVER TUNING control, to short out all except one turn.

g. Set the CHANNEL A DRIVER TUNING control to a dial setting of 12.

h. Set the CHANNEL A PA TUNE control to a dial setting of 68.

i. Open the knife blade switch that is located directly below C26 which connects C26 to the parallel combination of C92 and C38.

j. Set the lower shorting clip to the lowest turn possible on L14, and the upper shorting clip to turn 18 on the coil. Lock both clips in place.

## SECTION II

### Installation

- k. Open both the knife blade switches that are located directly below capacitors C42 and C44.
- l. Set the CHANNEL A PA LOAD control to a dial setting of 50.
- m. Set the DR TUNE-PA TUNE-OPERATE switch in the DR TUNE position.
- n. Place the MULTIMETER switch in the PA LOAD position.
- o. Close the upper cabinet door. Place the external disconnect switch in the ON position. Depress the PLATE ON switch.
- p. After the plate indicator lights, set the controls of the associated exciter to produce an unmodulated r-f signal of approximately 26 megacycles. Increase the level of this signal until an indication is observed on the MULTIMETER.
- q. Alternately adjust the CHANNEL A INPUT AMP TUNING and CHANNEL A DRIVER TUNING controls for a maximum indication on the MULTIMETER. Adjust the input signal level at the exciter unit until the MULTIMETER indication is approximately half scale. Readjust the CHANNEL A INPUT AMP TUNING and CHANNEL A DRIVER TUNING controls for a maximum indication on the MULTIMETER. Reduce the r-f signal level at the exciter until there is no visible indication on the MULTIMETER.
- r. Place the MULTIMETER switch in the LT PA CATH position, and the DR TUNE-PA TUNE-OPERATE switch in the PA TUNE position. Turn the LEFT PA BIAS adjustment until the MULTIMETER is indicating 250 milliamperes. Place the MULTIMETER switch in the RT PA CATH position, and turn the RIGHT PA BIAS adjustment until the MULTIMETER is indicating 250 milliamperes.
- s. Place the MULTIMETER switch in the PA LOAD position. Increase the r-f signal level at the exciter until the indication on the MULTIMETER is approximately one-third scale. Adjust the CHANNEL A PA TUNE control for a dip in the indication on the MULTIMETER.
- t. Increase the r-f signal level at the exciter until the PLATE CURRENT meter is indicating 0.8 amperes.
- u. Place the MULTIMETER switch first in the LT PA CATH position and then in the RT PA CATH position. If the indications on the MULTIMETER are not approximately equal, adjust the PA GD BAL control until the currents are in balance.
- v. Alternately place the MULTIMETER switch in the PA LOAD and PA SCREEN positions and increase the r-f signal level at the exciter unit. Keep adjusting the CHANNEL A PA TUNE control for a dip as indicated on the MULTIMETER and monitoring the power amplifier screen current as the r-f signal is increased. If necessary, adjust the CHANNEL A PA LOAD control to maintain the power amplifier screen current at a maximum of 75 milliamperes. Increase the r-f signal level until the PLATE CURRENT meter is indicating 1.45 amperes.

#### 2.4.9 R-F VOLTMETER CALIBRATION.

After the r-f amplifier circuits are checked as described in paragraph 2.4.8, check the calibration of the r-f voltmeter circuit as follows:

- a. Place the MULTIMETER switch in the PA LOAD position.
- b. Observe that the needle on the MULTIMETER is indicating exactly zero.
- c. If the MULTIMETER indication is not correct, adjust R42 for proper indication.

NOTE

R42 is located in the grid box, and cannot be adjusted with power applied. To perform this adjustment de-energize the equipment, open the upper cabinet door, turn the adjustment slightly in one direction, reenergize the equipment, and observe the effect. Repeat this procedure until the proper indication is obtained.

2.4.10 PLATE OVERLOAD CIRCUIT.

After the r-f voltmeter calibration is checked as described in paragraph 2.4.9, check the plate overload circuit as follows:

- a. Place the MULTIMETER switch in the PA SCREEN position.
- b. Increase the r-f signal level at the exciter until the plate overload circuit operates. Operation of the overload circuit, which is indicated by the PLATE indicator being extinguished, should occur when the PLATE CURRENT meter is indicating between 1.6 and 1.7 amperes.

CAUTION

Do not let the power amplifier screen current exceed 80 milliamperes. Reduce the amount of screen current with the CHANNEL A PA LOAD control if necessary.

- c. Decrease the r-f signal level at the exciter unit.
- d. Depress the PLATE OFF switch, wait approximately three minutes, then depress the FILAMENTS OFF switch.
- e. Place the external disconnect switch in the OFF position.

2.4.11 TGC CIRCUIT.

After the plate overload circuit is checked as described in paragraph 2.4.10 check the operation of the TGC circuit as follows:

- a. Observe that the external disconnect switch is in the OFF position.
- b. Insert a probe T connector (Hewlett Packard 455A or equivalent) in series with the transmission line that is connected to DC1.
- c. Disconnect the coaxial cable that couples the TGC signal to the channel A frequency source at the r-f signal source end. Connect a dummy load, which consists of a one megohm resistor and a one microfarad capacitor in parallel, across the cable terminals. Connect a Hewlett Packard Model 410B, or equivalent, vacuum tube voltmeter across the dummy load. Connect the meter to read a negative voltage of greater than ten volts.
- d. Connect a single-tone, audio signal to the input of the associated exciter unit. Set the exciter unit controls to produce a single sideband signal at the frequency to which the channel A circuits are tuned.
- e. Connect a Hewlett Packard Model 410B vacuum tube voltmeter that is equipped with a Hewlett Packard 453A capacitive voltage divider, or equivalent, to the probe T connector. Set the meter to read an a-c voltage of greater than 35 volts.

SECTION II  
Installation

NOTE

The meter will be used to measure a voltage of approximately 355 volts, but the capacitive voltage divider provides a ten-to-one step down ratio.

- f. Place the external disconnect switch in the ON position, and depress the PLATE ON switch.
- g. After the PLATE indicator lights, increase the audio signal level of the input to the exciter until the vtvm that is connected to the T connector gives an indication of 35.5 volts. Observe that the other voltmeter is indicating exactly -10 volts d-c. If the voltmeter is not indicating exactly -10 volts, turn the TGC adjustment until the meter does indicate the correct voltage.
- h. Reduce the level of the audio signal to the exciter until the voltmeter that is connected to the T connector is indicating 31.6 volts. Observe that the other voltmeter indicates less than 0.3 volts d-c.
- i. Depress the PLATE OFF switch, wait approximately three minutes, and depress the FILAMENTS OFF switch. Place the external disconnect switch in the OFF position.
- j. Disconnect the voltmeter from the TGC dummy load, but leave the other voltmeter connected.
- k. Disconnect the dummy load from the coaxial cable, and reconnect the cable to the associated exciter unit.

2.4.12 POWER AMPLIFIER NEUTRALIZATION.

After the operation of the TGC circuit is checked as described in paragraph 2.4.11, perform the following steps to check the neutralization of the power amplifier stage.

- a. Place the external disconnect switch in the ON position, and depress the PLATE ON switch.
- b. After the PLATE indicator lights, increase the level of the audio signal input to the exciter unit until the voltmeter connected to the T connector is indicating approximately 30 volts.
- c. Rock the CHANNEL A PA TUNE control. Observe that the indication on the voltmeter reaches a peak at the same time that the indication on the PLATE CURRENT meter reaches a minimum.
- d. If the indication on the voltmeter reaches a peak and the indication on the PLATE CURRENT meter reaches a minimum at the same time, the power amplifier stage is properly neutralized, and step e. through i. may be ignored. If the power amplifier stage is not properly neutralized, perform steps e. through i.
- e. Observe whether the voltmeter indication reaches a maximum or the PLATE CURRENT meter indication reaches a minimum first as the CHANNEL A PA TUNE control is rotated clockwise.
- f. Depress the PLATE OFF switch, wait approximately three minutes, and depress the FILAMENTS OFF switch. Place the external disconnect switch in the OFF position.
- g. Open the upper cabinet door. Adjust C18, which is located in the r-f compartment, one turn either clockwise or counterclockwise depending on the indication obtained in step e. If the



voltmeter indication reached a maximum first, decrease the capacity of C18. If the PLATE CURRENT reached a minimum first, increase the capacity of C18.

h. Close the upper cabinet door, place the external disconnect switch in the ON position, and depress the PLATE ON switch.

i. After the PLATE indicator lights, repeat steps c. and d. until proper neutralization is obtained.

j. When the power amplifier stage is properly neutralized, depress the PLATE OFF switch. Wait approximately three minutes, then depress the FILAMENTS OFF switch, and place the external disconnect switch in the OFF position.

k. Disconnect the voltmeter from the T connector, and remove the T connector from the output transmission line.

#### 2.4.13 DRIVER AMPLIFIER NEUTRALIZATION.

After the power amplifier stage is properly neutralized as described in paragraph 2.4.12, proceed as follows to check the neutralization of the driver amplifier stage.

a. Observe that the external disconnect switch is in the OFF position. Open both the upper and lower cabinet doors.

b. Connect a Hewlett Packard Model 410B, or equivalent, voltmeter to the control grid of either V2 or V3. Connect a second Hewlett Packard Model 410B, or equivalent, voltmeter to the plate of the same tube. Set the meter that is connected to the grid to read a voltage of approximately 10 volts a-c. Set the second meter to read an a-c voltage of greater than 100 volts.

#### NOTE

Both voltmeters should be located outside of the cabinet, and the meter leads run through the power supply compartment and up through the access holes in the panel that separates the grid and power supply compartments.

c. Block the lower door interlock switch in the closed position, and leave the lower cabinet door open. Close the upper cabinet door.

d. Place the DR TUNE-PA TUNE-OPERATE switch in the OPERATE position.

e. Depress the PLATE ON switch, and observe that the PLATE indicator lights within three minutes.

f. After the PLATE indicator lights, increase the level of the audio signal input to the associated exciter unit until the voltmeter that is connected to the plate of either V2 or V3 is indicating approximately 100 volts a-c.

g. Adjust both the CHANNEL A INPUT AMP TUNING and CHANNEL A DRIVER TUNING controls for a maximum indication on this same voltmeter.

**SECTION II**  
**Installation**

h. Rock the CHANNEL A DRIVER TUNING control. Observe that indication on the meter that is connected to the grid of either V2 or V3 does not change as the control is moved.

**NOTE**

An unneutralized circuit will cause the driver grid voltage to decrease as the tuning control is moved either side of resonance. Since the driver stage is being operated class AB<sub>1</sub>, the voltage decrease in the grid circuit will be small. The voltage decrease may only be 0.5 volts.

i. If the indication on the grid circuit meter does not vary as the CHANNEL A DRIVER TUNING control is moved, ignore steps j. through m. If neutralization is required, perform steps j. through m.

j. Depress the PLATE OFF switch, wait approximately three minutes, then depress the FILAMENTS OFF switch. Place the external disconnect switch in the OFF position.

k. Open the upper cabinet door. Adjust C10, which is located in the grid box adjacent to V2 and V3, approximately one turn in either direction.

l. Close the upper cabinet door, and repeat steps e. through h. Observe the effect of adjusting C10. Repeat steps j. and k., and adjust C10 in the proper direction.

m. Repeat step l. as many times as necessary to obtain exact neutralization.

n. Depress the PLATE OFF switch, wait approximately three minutes, and then depress the FILAMENTS OFF switch.

o. Place the external disconnect switch in the OFF position. Open the upper cabinet door, and disconnect both voltmeters.

p. Remove the block from the lower door interlock switch.

**2.4.14 PREPARATION FOR NORMAL OPERATION.**

After all the checks that are described in paragraphs 2.4.2 through 2.4.13 have been accomplished, prepare the equipment for normal operation as follows:

a. Observe that the external disconnect switch is in the OFF position, and both cabinet doors are open.

b. Remove the grid box from the cabinet.

**NOTE**

The grid box is removed from the cabinet by removing the knob from the MULTIMETER switch, loosening six twist-lock screws, pulling the grid box slightly forward, disconnecting coaxial connector P7 from J7, and pulling the grid box straight forward out of the box.

c. Replace the two access hole cover plates, which are used to cover the two openings in the shelf that separates the power supply and grid compartments.

30R

- d. Disconnect C4, which is located in the grid box, from the grounding post, and reconnect to its mounting post.
- e. Replace the grid box in the cabinet.
- f. Remove the jumpers installed on TB2, and replace the control circuit wiring removed in step e of paragraph 2.4.2.
- g. Close both the upper and lower cabinet doors.

### SECTION III

### OPERATION

#### 3.1 GENERAL.

Linear Power Amplifier 204F-1 is designed for either attended or unattended operation. Power supply and frequency selection circuits can be controlled locally or remotely. All power supply circuits are equipped with protective devices that prevent damage to the equipment or injury to operating personnel. Either of two complete sets of tuned circuits may be selected by relay action. Each set of tuned circuits may be tuned to any frequency in the range between 2 and 30 megacycles. Each set of tuned circuits must be pretuned to the desired frequency. Variable capacitors, tapped coils, and padding capacitors are provided in each set of tuned circuits.

#### WARNING

303  
The operation of Linear Power Amplifier 204F-1 involves the use of high voltages that could be fatal. Under no circumstances should any person reach within the cabinet without the immediate presence of another person who is capable of rendering aid. Do not depend on interlocks or shorting switches. Always use the high voltage shorting sticks that are furnished.

#### 3.2 LOCATIONS AND FUNCTIONS OF ADJUSTMENTS, CONTROLS, AND INDICATORS.

Figure 3-1 shows the location of the adjustments, controls and indicators that are used to operate the linear power amplifier. The functions of these adjustments, controls, and indicators are discussed in the following sub-paragraphs:

##### 3.2.1 POWER SUPPLY CIRCUITS.

The majority of the adjustments, controls and indicators of the 204F-1 are associated with the power supply and power control circuits. These items are located on the upper cabinet door, behind the upper hinged panel in the upper cabinet door and behind the lower cabinet door in the power supply compartment. The filament circuits are energized by the FILAMENTS ON push-button switch and deenergized by the FILAMENTS OFF pushbutton switch when the LOCAL-REMOTE switch is in the LOCAL or REMOTE position. In addition the filament circuits can be energized from a remote location when the LOCAL-REMOTE switch is placed in the REMOTE position. Whenever the filament circuits are energized, the FILAMENTS indicator is illuminated. The voltage applied to the filaments of all tubes, except the two high voltage rectifiers, is adjusted by means of the PA FILAMENT control. When the MULTIMETER switch is placed in the PA FIL VOLTS position, the value of voltage being supplied to the left power amplifier tube (V4) filament is indicated on the MULTIMETER. The bias, screen, and plate supply circuits are energized by

**SECTION III**  
**Operation**

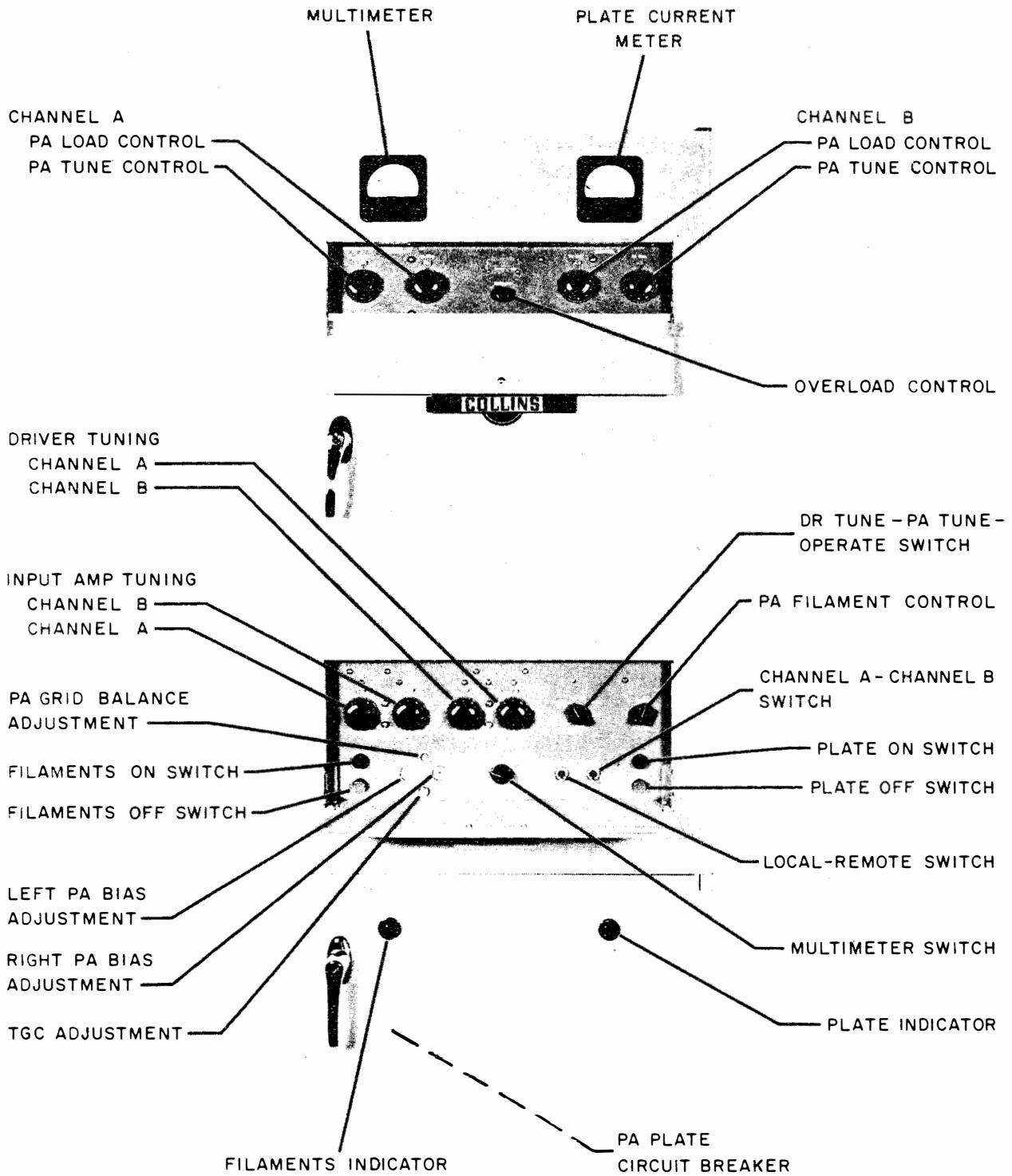

**Figure 3-1. Linear Power Amplifier 204F-1, Operating Controls**

the PLATE ON switch, when the LOCAL-REMOTE switch is in the LOCAL or REMOTE positions, and by a similar switch in the remote circuits when the LOCAL-REMOTE switch is in the REMOTE position. The bias, screen, and plate supply circuits can be deenergized by either the FILAMENTS OFF or PLATE OFF switches when the LOCAL-REMOTE switch is in the LOCAL position, and by these same switches or a similar switch in the remote control circuits when the LOCAL-REMOTE switch is in the REMOTE position.

The power control circuit of the 204F-1 is so designed that the screen and plate supply circuits cannot be energized until the filament circuits have been energized for a predetermined time (approximately three minutes). If the PLATE ON switch is depressed before the FILAMENTS ON switch, or the switch in the remote circuit that is similar to the PLATE ON switch is depressed when the LOCAL-REMOTE switch is in the REMOTE position, the filament control circuit and bias will be energized first, then after a preset time delay, the screen and plate supply circuits will be energized. Regardless of the methods, the PLATE indicator will be illuminated whenever the screen and plate supply circuits are energized.

Fixed values of bias are applied to the input and driver amplifier stages. The bias applied to each of the power amplifier tubes can be individually set. The adjustment that is labeled LEFT PA BIAS determines the value of bias voltage applied to V4. The RIGHT PA BIAS adjustment determines the value of bias voltage applied to V5.

A built-in multimeter circuit is provided to measure pertinent voltages without the need of connecting test equipment to the 204F-1. An eight-position wafer switch, which is labeled MULTIMETER, is used to connect the panel meter labeled MULTIMETER across appropriate shunt resistances. The function measured and the scale of the meter for each position of the MULTIMETER switch are clearly marked adjacent to the control.

The TGC adjustment is provided to set the operating point of the TGC circuit, which controls the level of the r-f input to the 204F-1. The OVERLOAD control is provided to set the operating point of the thermal overload circuit, which ensures that power will not be applied to the bias, screen, and plate circuits unless adequate cooling air is being supplied to the 204F-1. The PLATE CURRENT meter is connected directly into the power amplifier stage anode circuit, and continuously indicates power amplifier stage plate current.

### 3.2.2 RADIO FREQUENCY AMPLIFIER CIRCUITS.

Each of the three stages of r-f amplification in the 204F-1 contain two complete sets of tuned circuit components. Relay action, which is controlled by the CHANNEL A-CHANNEL B switch, is used to select the appropriate set of components. When this switch is in the CHANNEL A position, the CHANNEL A INPUT AMP TUNING control is used to tune the input amplifier stage, the CHANNEL A DRIVER TUNING control is used to tune the driver amplifier stage, and the CHANNEL A PA TUNE and CHANNEL A PA LOAD controls are used to tune and load the channel A output network. Placing the switch in the CHANNEL B position provides that the CHANNEL B INPUT AMP TUNING control tunes the input amplifier stage, the CHANNEL B DRIVER TUNING control tunes the driver amplifier stage, and that the CHANNEL B PA TUNE and CHANNEL B PA LOAD controls are used to tune and load the channel B output network. The MULTIMETER switch and meter are used during the tuning process. The PA GD BAL adjustment is used in either position of the CHANNEL A-CHANNEL B switch to adjust the dynamic cathode current of the tubes in the power amplifier stage.

### 3.3 LOCAL OPERATION.

Before attempting to operate the linear power amplifier it should be determined that the 204F-1 is properly installed and the initial checks and adjustments have been made as described in Section II of this manual. It should also be determined that the associated equipment is properly installed and tested as described in the system instruction book.

SECTION III  
Operation

3.3.1 PRE-OPERATION PROCEDURE.

Before attempting to place the linear power amplifier in service for the first time, after any maintenance is performed, or after an extended shutdown, the following precautionary steps shall be taken:

- a. Place the external disconnect switch in the OFF position.
- b. Open the upper cabinet door. Visually inspect the interior of the cabinet for loose connections, foreign material, and obvious signs of damage. Observe that the power amplifier tube air chimneys are properly installed. Close the upper cabinet door.
- c. Open the lower cabinet door. Inspect the interior of the cabinet for loose connections, foreign material, and obvious signs of damage. Check to see that all active fuseholders contain a fuse of the right value. Observe that the PA PLATE circuit breaker is in the ON position, reset if necessary. Close the lower cabinet door.
- d. Place the CHANNEL A-CHANNEL B switch in the CHANNEL A position, the LOCAL-REMOTE switch in the LOCAL position, the DR TUNE-PA TUNE-OPERATE switch in the DR TUNE position, and the MULTIMETER switch in the PA FIL VOLTS position. Turn the PA FILAMENT adjustment fully counterclockwise.
- e. Place the external disconnect switch in the ON position. Depress the FILAMENTS ON switch. Observe that the FILAMENTS indicator is lit. Determine that the blower motor is operating without excessive noise.
- f. Observe the MULTIMETER and adjust the PA FILAMENT control for a reading of exactly six volts.
- g. Wait approximately three minutes, then depress the PLATE ON switch. Observe that the PLATE indicator is illuminated.
- h. Place the MULTIMETER switch in the PA PLATE VOLTS position. Observe that the MULTIMETER is indicating approximately 3200 volts.
- i. Determine that the associated exciter unit is not delivering a signal to the linear power amplifier, then place the DR TUNE-PA TUNE-OPERATE switch in the OPERATE position.
- j. Place the MULTIMETER switch in the DRIVER PLATE position. Observe that the MULTIMETER is indicating approximately 120 milliamperes.
- k. Place the MULTIMETER switch in the LT PA CATH position. Observe that the MULTIMETER is indicating 250 milliamperes. Adjust the LEFT PA BIAS adjustment to obtain this reading if necessary.
- l. Place the MULTIMETER switch in the RT PA CATH position. Observe that the MULTIMETER is indicating 250 milliamperes. Adjust the RIGHT PA BIAS adjustment to obtain this reading if necessary.
- m. Observe that the PLATE CURRENT meter is indicating 0.5 amperes.
- n. Place the MULTIMETER switch in the PA SCREEN position, and observe that the MULTIMETER is indicating zero milliamperes.
- o. Place the MULTIMETER switch in the PA GRID position. Observe that the MULTIMETER is indicating zero milliamperes.

206

p. Depress the PLATE OFF switch, wait approximately three minutes, then depress the FILAMENTS OFF switch. Place the external disconnect switch in the OFF position.

### 3.4 TUNING PROCEDURE.

The linear power amplifier contains two complete sets of tuned circuit components in the input amplifier stage, driver amplifier stage, and in the output network. Selection of one set of components in each amplifier stage and the output network is accomplished through relay action. The various relays involved are controlled by the CHANNEL A-CHANNEL B switch. Hence, the two sets of components are referred to as the channel A and channel B circuits. Each set of components may be tuned to any frequency in the range between 2 and 30 megacycles. Continuously variable capacitors, tapped coils, and padding capacitors are provided to cover this frequency range. A guide to the setting of the variable capacitors, setting of the taps on the coils, and amount of padding capacity required for a given frequency is presented in the form of a tuning chart that is fastened to the rear surface of the lower hinged panel on the upper cabinet door.

#### 3.4.1 CHANNEL A TUNING PROCEDURE.

The tuned circuit components that are selected when the CHANNEL A-CHANNEL B switch is in the CHANNEL A position are set to a given frequency as follows:

a. Remove all power from the 204F-1 by depressing the FILAMENTS OFF switch and then placing the external disconnect switch in the OFF position.

b. Open the upper cabinet door. Set the turn shorting device on L1, which is located in the left half of grid box directly above the CHANNEL A INPUT AMP TUNING control, to the number of turns specified in the Coil Turns column under the Input Amp Plate heading of the tuning chart. Set the shorting device by lifting the support rod slightly and sliding the shorting contact.

c. Set the turn shorting device on L6, which is located in the right half of the grid box directly above the CHANNEL A DRIVER TUNING control, to the number of turns specified in the Coil Turns column under the Driver Plate heading of the tuning chart.

d. Set the CHANNEL A INPUT AMP TUNING and CHANNEL A DRIVER TUNING controls to the setting indicated in the tuning chart. Interpolate where necessary.

e. Set the CHANNEL A PA TUNE control, which is located on the narrow panel at the top of the r-f compartment, to the setting indicated in the tuning chart. The information listed in the Variable column under the PA Plate Tuning Cap heading should be used. Interpolate if necessary.

f. Note the information in the Fixed column under the PA Plate Tuning Cap heading. (The first figure given is the value of capacitance that should be connected in parallel with capacitor C26, if the operating frequency lies in the lower half of the frequency band.) Refer to table 3-1 to determine the method of obtaining this capacitance. Connect the proper capacitors in parallel with C26.

g. Set the lower shorting clip on L14, which is located in the left half of the r-f compartment, to the number of turns specified in the PA Coil Turns column of the tuning chart. Set the upper

**SECTION III**  
**Operation**

shorting clip to turn number 18, or on the turn which is half way between the turn to which the lower clip is set and the top turn, whichever is greater.

h. Set the CHANNEL A PA LOAD control to the setting indicated in the Variable column under the PA Plate Loading Cap heading in the tuning chart Interpolate if necessary.

**TABLE 3-1. PADDING CAPACITY SELECTION**

VALUE OF PADDING CAPACITY	CAPACITORS IN PARALLEL WITH C26								
	C92	C38	C28	C30	C36	C90	C46	C34	C32
547	C92	C38	C28	C30	C36	C90	C46	C34	C32
472	C92	C38	C28	C30	C36	C90	C46	C34	
322	C92	C38	C28	C30	C36	C90			
247	C92	C38	C28	C30	C36				
172	C92	C38	C28	C30					
97	C92	C38	C28						
50	C92	C38							

**NOTE:** Capacitors C92 and C38 are permanently connected in parallel, and may be connected to C26 by closing a knife blade type switch that is located directly below C26 in the r-f compartment. C28, C30, C36, C90, C46, C34 and C32 are connected together and to the combination of C92, C38 by removable links.

i. Note the value of capacitance indicated in the Fixed column under the PA plate Loading Cap heading of the tuning chart. The two figures given are the values of capacitance that should be placed in parallel with C40 when the operating frequency lies in the lower and upper half of the frequency band, respectively. If the value of capacitance required is 2400 micromicrofarads, connect both C42 and C44 in parallel with C40. This is accomplished by closing the two knife blade type switches that are located directly beneath the capacitors. If 1600 micromicrofarads are required, connect C44 in parallel with C40. When 800 micromicrofarads are required, connect C42 in parallel with C40.

j. Place the MULTIMETER switch in the PA FIL VOLTS position, the CHANNEL A-CHANNEL B switch in the CHANNEL A position, the DR TUNE-PA TUNE-OPERATE switch in the DR TUNE position, and the LOCAL-REMOTE switch in the LOCAL position.

k. Close both the upper and lower cabinet doors. Place the external disconnect switch in the ON position. Depress the PLATE ON switch. Observe that the FILAMENTS indicator lights immediately, and that the PLATE indicator lights approximately three minutes later.

l. Observe that the MULTIMETER is indicating exactly six volts. Adjust the PA FILAMENT control to obtain this reading if necessary.

m. Place the MULTIMETER switch in the PA LOAD position. Determine that the associated exciter unit is delivering a signal of the proper frequency and of normal amplitude to the linear power amplifier.



- n. Adjust the CHANNEL A INPUT AMP TUNING control for a maximum indication on the MULTIMETER. Adjust the CHANNEL A DRIVE TUNING control for a maximum indication on the MULTIMETER.
- o. Place the DR TUNE-PA TUNE-OPERATE switch in the PA TUNE position. Determine that the keying relay is energized.
- p. Adjust the CHANNEL A PA TUNE control for a dip in the indication on the MULTIMETER. Adjust the CHANNEL A PA LOAD control for a zero indication on the MULTIMETER.
- q. Readjust the CHANNEL A PA TUNE control for a dip in the indication on the MULTIMETER.
- r. Place the MULTIMETER switch in the PA SCREEN position, and the DR TUNE-PA TUNE-OPERATE switch in the OPERATE position. Observe that the MULTIMETER is indicating less than 80 milliamperes, and the PLATE CURRENT meter is indicating less than 1.5 amperes.

#### CAUTION

If the MULTIMETER or PLATE CURRENT meter indication exceed the stated values, immediately depress the FILAMENTS OFF switch. Check the setting of the TGC adjustment as described in Section V.

#### 3.4.2 CHANNEL B TUNING PROCEDURE.

The tuned circuit components that are selected when the CHANNEL A-CHANNEL B switch is in the CHANNEL B position are set to a given frequency as follows:

- a. Remove all power from the 204F-1 by depressing the FILAMENTS OFF switch and then placing the external disconnect switch in the OFF position.
- b. Open the upper cabinet door. Set the turn shorting device on L2, which is located in the left half of the grid box directly above the CHANNEL B INPUT AMP TUNING control, to the number of turns specified in the Coil Turns column under the Input Amp Plate heading of the tuning chart. Set the shorting device by lifting the support rod slightly and sliding the shorting contact.
- c. Set the turn shorting device on L6, which is located in the right half of the grid box directly above the CHANNEL B DRIVER TUNING control, to the number of turns specified in Coil Turns column under the Driver Plate heading of the tuning chart.
- d. Set the CHANNEL B INPUT AMP TUNING control to the dial setting indicated in the Tuning column under the Input Amp Plate heading of the tuning chart. Set the CHANNEL B DRIVER TUNING control to the dial setting indicated in the Tuning column under the Driver Plate heading of the tuning chart. Interpolate where necessary.
- e. Set the CHANNEL B PA TUNE control, which is located on the narrow panel at the top of the r-f compartment, to the setting indicated in the tuning chart. The information listed in the Variable column under the Pa Plate Tuning Cap heading should be used. Interpolate if necessary.
- f. Note the information in the Fixed column under the Pa Plate Tuning Cap heading. (The first figure given is the value of capacitance that should be connected in parallel with capacitor C27, if the operating frequency lies in the lower half of the frequency band). Refer to table 3-2 to determine the method of obtaining this capacitance. Connect the proper capacitors in parallel with C27.

### SECTION III

#### Operation

g. Set the lower shorting clip on L15, which located in the right half of the r-f compartment, to the number of turns specified in the Pa Coil Turns column of the tuning chart. Set the upper shorting clip to turn number 18, or on the turn which is half way between the turn to which the lower clip is set and the top turn, whichever is greater.

h. Set the CHANNEL B PA LOAD control to the setting indicated in the Variable column under the Pa Plate Loading Cap heading in the tuning chart. Interpolate if necessary.

i. Note the value of capacitance indicated in the Fixed column under the Pa Plate Loading Cap heading of the tuning chart. The two figures given are the values of capacitance that should be placed in parallel with C41 when the operating frequency lies in the lower and upper half of the frequency band, respectively. If the value of capacitance required is 2400 micromicrofarads, connect both C43 and C45 in parallel with C41. This is accomplished by closing the two knife blade type switches that are located directly beneath the capacitors. If 1600 micromicrofarads are required, connect C45 in parallel with C41. When 800 micromicrofarads are required, connect C43 in parallel with C41.

TABLE 3-2. PADDING CAPACITY SELECTION

VALUE OF PADDING CAPACITY	CAPACITORS IN PARALLEL WITH C27								
	C47	C35	C33	C31	C37	C89	C91	C39	C29
547	C47	C35	C33	C31	C37	C89	C91	C39	C29
472	C47	C35	C33	C31	C37	C89	C91	C39	
322	C47	C35	C33	C31	C37	C89			
247	C47	C35	C33	C31	C37				
172	C47	C35	C33	C31					
97	C47	C35	C33						
50	C47	C35							

NOTE: Capacitors C47 and C35 are permanently connected in parallel, and may be connected to C27 by closing a knife blade type switch that is located directly below C27 in the r-f compartment. C33, C31, C37, C89, C91, C39 and C29 are connected together and to the combination of C47 and C35 by removeable links.

j. Place the CHANNEL A-CHANNEL B switch in the CHANNEL B position, the DR TUNE-PA TUNE-OPERATE switch in the DR TUNE position, and the LOCAL-REMOTE switch in the LOCAL position.

k. Close both the upper and lower cabinet doors. Place the external disconnect switch in the ON position. Depress the PLATE ON switch. Observe that the FILAMENTS indicator lights immediately, and that the PLATE indicator lights approximately three minutes later.

l. Place the MULTIMETER switch in the PA FIL VOLTS position. Observe that the MULTIMETER is indicating exactly six volts. Adjust the PA FILAMENT control to obtain this reading if necessary.

m. Place the MULTIMETER switch in the PA LOAD position. Determine that the associated exciter unit is delivering a signal of the proper frequency and of normal amplitude to the linear power amplifier.

- n. Adjust the CHANNEL B INPUT AMP TUNING control for a maximum indication on the MULTIMETER. Adjust the CHANNEL B DRIVER TUNING control for a maximum indication on the MULTIMETER.
- o. Place the DR TUNE-PA TUNE-OPERATE switch in the PA TUNE position. Determine that the keying relay is energized.
- p. Adjust the CHANNEL B PA TUNE control for a dip in the indication on the MULTIMETER. Adjust the CHANNEL B PA LOAD control for a zero indication on the MULTIMETER.
- q. Readjust the CHANNEL B PA TUNE control for a dip in the indication on the MULTIMETER.
- r. Place the MULTIMETER switch in the PA SCREEN position, and the DR TUNE-PA TUNE-OPERATE switch in the OPERATE position. Observe that the MULTIMETER is indicating less than 80 milliamperes, and that the PLATE CURRENT meter is indicating less than 1.5 amperes.

#### CAUTION

If the MULTIMETER or PLATE CURRENT meter indications exceed the stated values, immediately depress the FILAMENTS OFF switch. Check the setting of the TGC adjustment as described in Section V.

#### 3.5 LOCAL OPERATION STARTING PROCEDURE.

If the pre-operation precautions described in paragraph 3.3 have been observed, and the linear power amplifier has been tuned as described in paragraph 3.4, the 204F-1 can be operated locally as follows:

- 311
- a. Place the MULTIMETER switch in the PA SCREEN position.
- b. Select the desired operating frequency by means of the CHANNEL A-CHANNEL B switch.
- c. Place the LOCAL-REMOTE switch in the LOCAL position.
- d. Place the external disconnect switch in the ON position.
- e. Depress the PLATE ON switch. Observe that the FILAMENTS indicator lights immediately, and the PLATE indicator lights approximately three minutes later.
- f. Place the MULTIMETER switch in the PA FIL VOLTS position. Observe that the MULTIMETER is indicating six volts. Adjust the PA FILAMENT control to obtain this reading if necessary. Return the MULTIMETER switch to the PA SCREEN position.
- g. Energize the keying relay, and observe that the MULTIMETER indication does not exceed 80 milliamperes, and the PLATE CURRENT meter indication does not exceed 1.5 amperes.

#### CAUTION

If the MULTIMETER or PLATE CURRENT meter indications exceed the above values, immediately depress the FILAMENTS OFF switch and perform corrective maintenance.

## SECTION III Operation

### 3.6 LOCAL OPERATION STOPPING PROCEDURE.

The linear power amplifier can be turned off by performing the following two steps. If for any reason it is desired to remove power from the screen and plate supply circuits but not the filament supply circuits, only the first step should be performed.

- a. Depress the PLATE OFF switch, and observe that the PLATE indicator is extinguished.
- b. Wait approximately three minutes, then depress the FILAMENT OFF switch. Observe that the FILAMENTS indicator is extinguished.

#### NOTE

Damage will not result if the three minute delay of step b. is not observed. This delay is recommended to allow cooling air from the blower to reduce the temperature of the power amplifier tubes in the interest of maximum tube life and also to prevent injury to maintenance personnel.

- c. Place the external disconnect switch in the OFF position.

### 3.7 EMERGENCY SHUT-DOWN PROCEDURE.

The linear power amplifier is equipped with adequate protective devices, but can be completely disabled in moments if any emergency should arise. It is recommended that the following steps be taken in an emergency:

- a. Depress the FILAMENTS OFF switch.
- b. Place the external disconnect switch in the OFF position.

### 3.8 OPERATION WHILE PERFORMING MAINTENANCE.

The linear power amplifier is equipped with several protective devices that are designed to prevent injury to the equipment and operating personnel. These devices can be bypassed by a skilled technician, but should not be disabled unless absolutely necessary. The 204F-1 may be operated with the lower cabinet door open for purposes of maintenance, but should not be operated under any conditions with the upper cabinet door open.

### 3.9 REMOTE OPERATION.

The linear power amplifier is capable of being operated from a remote location. The exact manner in which this is accomplished will be determined by the individual installation, and will be described in the system instruction book.

### 3.10 OPERATION WITH OPTIONAL FEATURES.

The 204F-1 can be equipped with several optional features. In most cases the operation of the linear power amplifier will not be altered. In the installations where an optional feature does affect the operation of the 204F-1, revised operating procedures will be included in the system instruction book that applies to the installation.

## SECTION IV

## PRINCIPLES OF OPERATION

## 4.1 GENERAL.

Linear Power Amplifier 204F-1 is a three stage linear power amplifier that is designed to amplify radio frequency signals of approximately one-tenth watt amplitude to a level of 2.5 kilowatts and deliver this power to an associated antenna for transmission. Either of two operating frequencies, which are in the range between 2 and 30 megacycles, can be selected. Channel changing is accomplished by switching with relays between two sets of tuned circuits in each stage. Each channel is capable of being tuned to any frequency within the range of the equipment. All necessary operating voltages are developed within the equipment from an external source of single phase power. Power control circuits and a variety of protective devices provide a maximum of protection with a minimum of complexity. An integral blower unit is provided to maintain the equipment at the proper operating temperature.

## 4.2 POWER SUPPLY CIRCUITS.

All power to operate the circuits of the linear power amplifier enters the equipment as a single-phase voltage at the terminals of TB1 (see figure 7-1). This voltage may be at any level between 200 and 250 volts a-c, and may have a frequency of either 50 or 60 cps. This voltage is applied both directly and through power control circuitry to the filament, bias, screen, and plate supply circuits of the linear power amplifier. Primary power voltage is applied directly to the primary of transformer T1, which is a combination auto-transformer and step-down transformer. The auto-transformer feature of T1 is used to ensure that the level of voltage applied to filament transformers T2 and T4, and power transformer T3 is approximately 230 volts regardless of the level of the primary power input voltage. The step-down feature of T1 is used to supply operating voltages to power control, channel switching, TGC bias, and thermal overload circuits. The primary power voltage is applied through the contacts of relays K1, K4, and K6, which are controlled by a power control circuit, and circuit breaker CB1 to all filament, bias, screen, and plate supply circuits.

## 4.2.1 POWER CONTROL CIRCUITS.

The power control circuits of the linear power amplifier have two primary functions. The first is to provide the proper sequence of application of primary power to the various power supply circuits of the 204F-1. The second is the automatic removal of plate and screen supply voltages in case of an overload.

4.2.1.1 LOCAL OPERATION. The secondary voltage of T1, which is approximately 115 volts a-c, is used as a power control voltage throughout the 204F-1 when LOCAL-REMOTE switch S8 is in the LOCAL position. The power control voltage is connected through one pole of S8, lower door interlock S11-C, upper door interlock S12-C, power amplifier V4 air chimney interlock S13, power amplifier V5 air chimney interlock S14, and FILAMENTS OFF switch S1 to FILAMENTS ON switch S2. S2 is normally open, but when depressed connects the power control voltage to the coil of relay K1. Relay K1 is energized when S2 is depressed and remains so after S2 is released. Holding contacts provide that the power control voltage is applied to the coil of relay K1 and to the actuating circuit of time delay relay K2 whenever K1 is energized. The other contacts of relay K1 connect the primary power voltage through fuse F3 to blower motor B1, and a voltage of approximately 230 volts a-c from the primary of transformer T1 through fuse F5 to filament transformer T2, through fuse F2 to power transformer T3, and through air interlock switch S6 and fuse F4 to filament transformer T4. FILAMENTS indicator DS1 is connected in parallel with the coil of relay K1, and is provided to indicate that the relay is energized when S2 is depressed and remains so when S2 is released. The power control voltage at the load side of FILAMENTS OFF switch S1 is applied through PLATE OFF switch S3 to PLATE ON

## SECTION IV

### Principles of Operation

switch S4. When normally open switch S4 is closed, the power control voltage is applied through the normally closed contacts of relay K8, circuit breaker CB1, and thermal-overload switch S5 to the coil of relay K3. The coil circuit of relay K3 is completed through the normally closed contacts of relay K5. Relay K3 is energized when S4 is depressed, and remains energized when the switch is released due to the action of holding contacts on K3. The holding contacts on relay K3 also provide a path for the power control voltage to the contacts of time delay relay K2. The combined action of the holding contacts and a second set of contacts on the relay provide the same function as the FILAMENTS ON switch (apply the power control voltage to the coil of relay K1, indicator DS1, and the actuating circuit of time delay relay K2) during sequence-start operation. A third set of contacts on relay K3 provide a discharge path for capacitor C73, and are in use when the relay is deenergized.

Relay K2 is a time delay relay, and is set to close a pair of contacts approximately three minutes after the power control voltage is applied to its actuating circuit. If the FILAMENTS ON switch is depressed prior to depressing the PLATE ON switch, the power control voltage will be applied to the actuating circuit through the holding contacts on relay K1. If sequence-start operation is desired, the PLATE ON switch may be depressed without first depressing the FILAMENTS ON switch. This will apply the power control voltage to the coil circuit of relay K1, through the contacts of K3, and to the actuating circuit of relay K2 through contacts on relay K1. In either case, the contacts of relay K2 will not close until approximately three minutes after the power control voltage has been applied. This will allow time for the filament circuits, which are energized when relay K1 is energized, to warm up. If the FILAMENTS ON switch is depressed first and more than three minutes elapse before depressing the PLATE ON switch, the power control voltage from the holding contacts of relay K3 will be applied immediately to relay K4, PLATE indicator DS2, and a time delay circuit in the coil circuit of relay K6 when the PLATE ON switch is depressed. If the PLATE ON switch is depressed in less than three minutes after the FILAMENTS ON switch, the power control voltage will not be applied until the contacts of relay K2 close, which will be approximately three minutes after the FILAMENTS ON switch is depressed.

If relay K3 is energized and the contacts of relay K2 are closed, the power control voltage is applied to the coil of relay K4. (PLATE indicator DS2 is connected in parallel with the coil of relay K4 and is provided to indicate that relay K3 is energized and the contacts of relay K2 are closed). In the energized condition, the normally open contacts of relay K4 connect the primary power voltage present at the load side of circuit breaker CB1 to power transformers T5 and T6. The primary power voltage is applied to T5 and T6 through resistor R21, which is connected across the contacts of relay K6. R21 is a dropping resistor, and prevents the application of full primary power to the transformers. Fuse F6 is connected in the primary of T5, and provides overload protection for the transformer. Overload protection for T6 is provided by circuit breaker CB1.

The power control voltage is applied to the time delay circuit in the coil circuit of relay K6 at the same time it is applied to the coil of K4. This time delay circuit provides that relay K6 will not become energized until 0.15 seconds after relay K4. The power control voltage is rectified by CR16. The pulsed d-c from CR16 is used to charge C73, which is in parallel with the coil of relay K6. Approximately 0.15 seconds after the power control voltage is applied, the voltage developed across C73 is sufficient to energize relay K6 and does so. When relay K6 is energized, resistor R21 is shorted out and full primary power is applied to transformers T5 and T6. Whenever K3 is deenergized relays K4 and K6 are deenergized. One set of contacts on relay K3 is provided to discharge capacitor C73 so that the time delay circuit will control the operation of K6 when K3 is reenergized.

The power supply circuits of the linear power amplifier may be deenergized by depressing the PLATE OFF switch and then the FILAMENTS OFF switch, or by merely depressing the FILAMENTS OFF switch. If the PLATE OFF switch is depressed first and approximately three minutes are allowed to elapse before depressing the FILAMENTS OFF switch, plate and supply voltages will be removed from the r-f amplifier stage but cooling air will still be provided to reduce the temperature of components. This procedure is not required but is advisable. When the FILAMENTS OFF switch

is depressed, whether or not the **PLATE OFF** switch has been depressed, all filament, bias, screen, and plate voltages are removed from the r-f amplifier stages. Primary power is still present in the power supply compartment, and the 204F-1 can be completely deenergized only by placing the external disconnect switch in the **OFF** position.

**4.2.1.2 REMOTE OPERATION.** See figure 7-3 for typical remote circuit connections. The secondary voltage of T1 is brought out to terminal 9 of TB2, and may be used as the power control voltage when the **LOCAL-REMOTE** switch is placed in the **REMOTE** position. If it is to be used as the power control voltage, terminal 9 of TB2 will be connected through a normally closed switch in the remote control circuits to terminal 10 of TB2. If this voltage is not used, a voltage that originates in the remote control circuit may be connected through a normally closed switch, also in the remote control circuit, to terminal 10 of TB2. (This permits normal local operation even though the **LOCAL-REMOTE** switch is in the **REMOTE** position). The power control voltage at terminal 10 of TB2, regardless of source, is connected to a normally open switch in the remote control circuits. When this switch is depressed, the power control voltage is connected to terminal 12 of TB2. From this terminal, the power control voltage is connected through one pole of S8 and through the normally closed contacts of relay K8, circuit breaker CB1, and thermal-overload switch S5 to the coil of K3. The power control circuits will respond in the same manner as if the **PLATE ON** switch were depressed, but the **FILAMENTS ON** switch were not. (See paragraph 4.2.1.1).

**4.2.1.3 THERMAL OVERLOAD CIRCUIT.** When relay K3 is energized (as explained in the previous paragraphs), one set of contacts on the relay connects a voltage of approximately 25 volts a-c through **OVERLOAD** adjustment R22 to the heating element of thermal-overload switch S5. Cooling air from blower B1 passes over this heating element preventing the heat generated from affecting the switching element. If the blower should cease to operate, or if the temperature of the cooling air should rise above a certain level, the heat generated by the heating element will cause the switching element to operate. This will open the coil circuit of relay K3 and deenergize the relay. When relay K3 is deenergized, the power control voltage is removed from relays K4 and K6. This in turn removes primary power from the primaries of transformers T5 and T6. Transformers T5 and T6 supply the screen and plate supply circuits; therefore, screen and plate supply voltages are removed from the r-f amplifier stages.

**4.2.1.4 GRID OVERLOAD CIRCUIT.** If for any reason an excessive amount of grid current flows in the power amplifier stage, relay K5 will become energized. When relay K5 is energized, relay K3 is deenergized causing the removal of screen and plate voltages from the r-f amplifier stages (see paragraph 4.2.1.3).

**4.2.1.5 PLATE OVERLOAD CIRCUIT.** Relay K8 is energized when, for any reason, an excessive amount of plate current flows in the power amplifier stage. When relay K8 is energized, relay K3 is deenergized. When relay K3 is deenergized, screen and plate supply voltages are removed from all of the r-f amplifier stages (see paragraph 4.2.1.3).

**4.2.1.6 ONE-SHOT RECYCLE CIRCUIT.** A one-shot recycle unit, which is an optional feature on the 204F-1, may be connected to the power control circuits. Refer to figure 7-4 for a schematic of this unit and a typical method of connecting it to the 204F-1. A d-c voltage of approximately 28 volts positive with respect to ground is applied directly to terminal 4, and through toggle switches to terminals 2 and 3, of TB1 of the recycle unit. When the toggle switches are placed in the closed position, the d-c voltage is applied to the coil circuit of relays K1 and K2 of the recycle unit. When K2 is energized, the power control voltage from the secondary of T1 is connected to terminal 10 of TB2 and the d-c voltage is applied to terminal 1 of TB14 and to

## SECTION IV Principles of Operation

an alarm circuit. When K1 is energized, the power control voltage from the secondary of T1 is connected to terminal 12 of TB2. Sequence-start operation will take place (see paragraph 4.2.1.1). After approximately three minutes, the power control voltage will appear at terminal 4 of TB2, which is connected to the actuating circuit of timer B1 in the recycle unit. This timer is set to operate a set of contacts approximately five seconds after the power control voltage is applied. The contacts are located in series with the coil circuit of relay K1 in the recycle unit. Therefore, a little over three minutes after relay K1 is energized by operating a toggle switch in the remote control circuits, K1 is automatically deenergized. Terminals 1 and 2 of TB14 are jumpered by the contacts of relay K4 in the 204F-1 at approximately the same time as relay K1 in the recycle unit is deenergized. This connects the d-c voltage to the coil circuit of a relay in the remote control circuits. In the energized position of this relay, the d-c voltage is applied to an indicator lamp, which is used to indicate that the power circuits of the 204F-1 are energized. In the deenergized position, the d-c voltage is applied to an alarm circuit. A toggle switch is connected in the alarm circuit to prevent sounding an alarm during the first three minutes of operation. This switch is closed after the indicator lamp becomes lit.

When relay K3 is deenergized for any reason (overload or accidental depression of the PLATE OFF or FILAMENTS OFF switch), the remote control alarm circuit is energized and the recycle unit attempts to reenergize the power supply circuits of the 204F-1. The remote control alarm circuit is energized when relay K4 is deenergized, which occurs whenever relay K3 is deenergized. The power control voltage is no longer present at terminal 4 of TB2 when relay K3 is deenergized. The contacts of timer B1 close when the power control voltage is removed. When the contacts of the timer close, relay K1 in the recycle unit is energized. This connects the power control voltage to terminal 12 of TB2, hence to the coil of relay K3. Depending on whether the filament, bias, plate, and screen supplies, or just the plate and screen supplies have been deenergized, the power control voltage will be restored to the actuating circuit of timer B1 in three minutes or immediately. Relay K1 in the recycle unit will, therefore, be deenergized in either a little over three minutes or in approximately five seconds.

### 4.2.2 FILAMENT CIRCUITS.

The filament voltages for all tubes in the linear power amplifier are supplied from two transformers. Filament transformer T2 supplies approximately five volts a-c to operate the filaments of high voltage rectifier tubes V6 and V7. Filament transformer T4 supplies approximately 6.3 volts a-c to input amplifier tube V1 and to driver amplifier tubes V2 and V3, approximately 6.3 volts a-c to power amplifier tubes V4 and V5, and approximately 6.3 volts a-c to TGC tube V8. The exact value of voltage applied to the primaries of T2 and T4, hence the exact value of secondary voltages, is determined by the setting of the tap on transformer T1. A time lapse indicator, M4, is connected in parallel with the primary of T4, and is provided to indicate the time that power has been applied to the filaments of V4 and V5.

### 4.2.3 BIAS, SCREEN, AND PLATE SUPPLY CIRCUITS.

Three d-c power supply circuits are used to develop all the bias, screen, and plate supply voltages required to operate the linear power amplifier. Transformer T6, high voltage rectifiers V6 and V7, and associated component parts constitute a d-c power supply that develops a voltage of approximately 2700 volts. Transformer T5, silicon power rectifiers CR1 through CR12, and associated components develop a d-c voltage of approximately 300 volts. A d-c voltage of approximately 120 volts is developed in a supply circuit that consists of transformer T3, silicon power rectifiers CR17 through CR20, and associated components. The negative end of the 2700-volt supply is connected to the positive end of the 300-volt supply through meter M1 in series with resistor R46 and the coil of relay K8 in parallel. The negative end of the 300-volt supply is connected through the coil of K5 and meter shunt R49 to the positive end of the 120-volt supply.



## SECTION IV Principles of Operation

The output of the 300-volt supply is used to provide plate and screen supply voltages for the input amplifier and driver amplifier stages. The negative end of the supply is connected to the filament and cathode elements of these tubes while the positive end of the supply is connected to the plate and screen elements. The positive end of the 300-volt supply is connected to ground through meter shunt R27, and is therefore at ground potential.

The output of the 300-volt supply is also used to provide screen voltage and part of the plate voltage for the power amplifier stage. The cathode circuit of the power amplifier stage is returned to the negative terminal of the 300-volt supply, and the screen grid elements of the two power amplifier tubes are grounded. The positive end of the 2700-volt supply is connected to the plate circuit of the power amplifier stage. This combination effectively places a potential of 300 volts between screen and cathode and a potential of 3000 volts between plate and cathode. The negative end of the 300-volt power supply is connected to the cathode circuit of the power amplifier stage through the contacts of keying relay K7. Thus, there will be no screen or plate voltage on the power amplifier stage unless the keying relay is energized.

The outputs of the 300-volt and 120-volt power supplies are combined to provide fixed bias voltages for V4 and V5 in the power amplifier stage. The bias voltages for V4 and V5 are developed across R15 and R41 respectively. R15 and R41 are variable resistances. The bias voltage appearing at the arm of either resistor has a range of -35 to -85 volts with respect to the negative end of the 300-volt power supply (effectively the cathode of the power amplifier stage).

High voltage grounding switches S11 and S12 are connected to both the positive end of the 2700-volt supply and to the negative end of the 300-volt power supply. S11, which is the lower door interlock switch, automatically grounds these two points when the lower door is opened. S12, which is the upper door interlock switch, automatically grounds these same points when the upper door is opened.

### 4.3 RADIO FREQUENCY AMPLIFIER CIRCUITS.

See figure 7-2. The radio frequency amplifier circuits of the linear power amplifier consist of an input amplifier stage, driver amplifier stage, power amplifier stage, and an output network. An r-f signal that originates in the associated exciter unit is applied to the input amplifier stage at a level of approximately one-tenth watt (0.1 watt nominal and 0.2 watt maximum). This signal is amplified in the input amplifier, driver amplifier, and power amplifier stages and delivered through the output network to the associated antenna at levels of up to 2.5 kilowatts of peak envelope or average power. Swamping networks in the input amplifier and driver amplifier stages are designed to reduce variations in gain, and feedback around all three stages is designed to reduce distortion.

The input signal may be either one of two predetermined frequencies in the range between 2 and 30 megacycles. Relay action, which may be controlled either locally or remotely, is used to select either of two pretuned r-f channels.

All filament, bias, screen, and plate supply voltages that are required for the proper operation of the radio frequency amplifier stages are developed within the linear power amplifier. Filament transformer T4 supplies the filaments of V1 through V5. Cathode bias is developed in the input amplifier and driver amplifier stages, and fixed bias is supplied to the power amplifier stage. Plate and screen voltages for the input and driver amplifier stages are obtained from a 300-volt power supply. Screen voltage for the power amplifier stage is obtained from this same supply. Plate voltage for the power amplifier stage is obtained by combining the output of the 300-volt and 2700-volt power supplies. The cathode circuits of all three amplifier stages are operated at approximately 300 volts negative with respect to ground. The screen circuit of the power amplifier stage is operated at ground potential. The screen and plate elements of the input amplifier and driver amplifier stages are operated slightly negative with respect to ground. The plate circuit of the power amplifier stage is operated at approximately 2700 volts positive with respect to ground.

#### 4.3.1 INPUT AMPLIFIER STAGE.

The input amplifier stage consists of a single 6CL6 pentode tube, V1, and associated components. This stage is operated as a class A voltage amplifier. Filament voltage for V1 is supplied by filament transformer T4. Cathode bias is developed across R2. Plate and screen voltages are obtained from the 300-volt power supply circuit through dropping resistor R4. The supply side of R4 is connected to the positive end of the 300-volt supply, which is returned to ground through meter shunt R27. The grid and cathode circuits of V1 are returned to the negative end of the 300-volt supply through dropping resistor R40, which is shorted out when DR TUNE-PA TUNE-OPERATE switch S9 is in the OPERATE position. Therefore, the potential on the plate of V1 is negative with respect to ground, but positive with respect to the cathode. The amount of this voltage is determined by the position of S9, and is greater when S9 is in the OPERATE position. R7 and L3 keep r-f out of the power supply.

#### NOTE

If the linear power amplifier is furnished with a dual r-f input circuit, refer to figure 7-5.

The r-f signal from the associated exciter enters the linear power amplifier at r-f connector J1, and is coupled to the cathode circuit of V1 by a coaxial cable. An untuned input circuit terminates this input line, and connects the incoming signal to the cathode element of V1. (A second input to V1 is an r-f feedback signal from the power amplifier stage, which is applied to the control grid element). The amplified input signal is developed across either one of two tuned circuits in the plate circuit of V1. One tuned circuit, which is composed of L1 and C6, is connected into the plate circuit whenever relay K9 is energized. (This tuned circuit is referred to as the channel A tuned circuit inasmuch as relay K9 is energized when the CHANNEL A-CHANNEL B switch is in the CHANNEL A position). The other tuned circuit, which is composed of L2 and C7, is connected into the plate circuit of V1 when relay K9 is deenergized. To prevent loss of r-f energy, L1 is shorted out when L2 is in the circuit and vice-versa. Z1 is placed in the plate circuit of V1 to suppress parasitic oscillation. Inductors L1 and L2 are equipped with a turn shorting device that is manually positioned to short out an appropriate number of turns so that the tuned circuit will resonate at the correct operating frequency. The output of the input amplifier stage is coupled through capacitor C8 to the grid circuit of the driver amplifier stage. The series combination of L4 and R8 in the grid circuit of the driver amplifier stage is the swamping network for the input amplifier stage.

#### 4.3.2 DRIVER AMPLIFIER STAGE.

The driver amplifier stage utilizes a pair of 6146 tubes, V2 and V3, connected in parallel. This stage is operated as a class AB<sub>1</sub> voltage amplifier. Filament voltage for both V2 and V3 is obtained from the same winding of filament transformer T4. Cathode bias voltage is developed across resistors R9 and R10. Plate and screen supply voltage is obtained from the 300-volt power supply. The plate elements of V2 and V3 are connected to the positive end of the 300-volt power supply, which is effectively at ground potential, through r-f chokes L8 and L9 and meter shunt R18. Screen voltage is tapped off a divider network that consists of R11 and R12. This divider is connected between the positive end of the 300-volt power supply and the cathode circuit of V2 and V3. The cathode and grid circuits of V2 and V3 are returned to the negative end of the 300-volt supply through resistor R40, which is shorted out when S9 is in the OPERATE position.

The output of the input amplifier stage is coupled to the grid circuit of the driver amplifier stage through capacitor C8. The input signal is applied through parasitic suppressors Z3 and Z4 to the control grid elements of V2 and V3. The series combination of L4 and R8 provides a d-c return for the grid elements and also acts as a swamping network for the input amplifier stage. The input signal is amplified by the parallel combination of V2 and V3. The amplified input signal is coupled

through parasitic suppressor Z2 to the plate circuit of the driver amplifier stage. The plate circuit contains a swamping network and two tuned circuits. The swamping network, which consists of L5, R56 through R61, and C85, has the effect of reducing undesirable variations in gain. The combination of L6 and C14, which is referred to as the channel A tuned circuit, is connected into the plate circuit when relay K10 is energized. The combination of L7 and C15, which is referred to as the channel B tuned circuit, is connected into the plate circuit when relay K10 is deenergized. To conserve r-f energy, L6 is shorted out when L7 is in the circuit and vice-versa. Capacitor C10 is provided to neutralize the plate-to-grid capacity of the driver amplifier stage. Capacitor C12 couples a small portion of the driver amplifier stage output signal to a metering circuit. Inductors L6 and L7 are equipped with a turn shorting device. This device is manually set so that the tuned circuits will resonate at the proper frequency. The output of the driver amplifier stage is coupled to the power amplifier stage through capacitors C16, C99, C100, and parasitic suppressors Z5 and Z6.

#### 4.3.3 POWER AMPLIFIER STAGE.

The power amplifier stage uses a pair of 4CX1000A tubes connected in parallel. This stage is operated as a class AB<sub>1</sub> power amplifier. Filament voltage for V4 and V5 is obtained from filament transformer T4. The screen elements of V4 and V5 are connected directly to ground. The cathode element of V4 is connected through r-f choke L19, meter shunt R36, the contacts of relay K11 and either dropping resistor R69 or the contacts of relay K7 to the negative end of the 300-volt supply. The cathode of V5 is connected through r-f choke L20, meter shunt R37, the contacts of relay K11, and either dropping resistor R69 or the contacts of relay K7 to the negative end of the 300-volt supply. The plate elements of V4 and V5 are connected through r-f choke L12 to the positive end of the 2700-volt supply. The control grid of V4 is connected through r-f chokes L27 and L28 to LEFT PA BIAS adjustment R15. The control grid of V5 is connected to RIGHT PA BIAS adjustment R41 through r-f chokes L10 and L11.

The output of the driver amplifier stage is coupled through dual capacitor C16 to the grids of V4 and V5. The relative amount of signal input to each tube is determined by the setting of C16, which is mechanically driven by the PA GD BAL control. The input signal is amplified by V4 and V5 and delivered to the output network through capacitor C25. Capacitor C18 is provided to neutralize the plate-to-grid capacity of the power amplifier stage. Capacitor C2 couples a portion of the power amplifier stage output signal to the control grid circuit of the input amplifier stage (as an r-f feedback signal) and a portion to an output metering circuit.

#### 4.3.4 OUTPUT NETWORK.

The signal output of the power amplifier stage is connected through the contacts of relay K11 to either one of two Pi networks. One network is provided for each channel. The purpose of the network is to match the power amplifier stage to the associated antenna and to provide harmonic attenuation. The output of the network in use is connected through the contacts of relay K14 to directional coupler DC2. The r-f signal present at the output of DC2 is the r-f output of the linear power amplifier.

#### NOTE

If the linear power amplifier is equipped with the dual r-f output feature, refer to figure 7-5.

Relay K11 is an assembly of two relays that are designated K11A and K11B. Either K11A or K11B will be energized at all times that power is applied. Relay K11A will be energized when relay K12 is deenergized and channel A operation is desired. K11B will be energized when channel B operation is desired. When relay K11A is energized, the signal output of the power amplifier stage is connected to the network that contains C26, L14, and C40. Depending on the frequency of operation, C26 may be shunted by two or more capacitors (C92 and C38 in parallel, C28, C30, C36, C90, C46, C34, and C32). C92 and C38 in parallel are connected to C26 by the action of a knife

## SECTION IV

### Principles of Operation

blade switch that does not have a reference designation. C28, C30, C36, C90, C46, C34, and C32 are connected to the parallel combination of C92 and C38 and to each other by removable links. Two shorting clips are furnished on L14. One is used to select the proper number of turns for the operating frequency. The second shorting clip is used to divide the remaining shorted turns into two circuits. This configuration prevents the shorted turns from acting as a tuned circuit at a harmonic of the output frequency. Such a tuned circuit could absorb part of the r-f output power. To prevent the unused output network from absorbing any r-f power, the contacts of relay K11B, which is deenergized, short out L30 and L15. Capacitors C42 and C44 may be connected in parallel with C40. Either one or both of these capacitors may be placed in parallel with C40 through the action of knife blade type switches, which have not been assigned a reference designation. The output of the channel A network is coupled through the normally closed contacts of relay K14 to directional coupler DC2. The circuits of this unit both couple the r-f output to a transmission line that connects to the associated antenna and produces a current that is proportional to the amount of r-f power output. The circuits of DC2 that produce this current are brought out to the terminals of TB14. These terminals may be used to connect a meter, which when properly calibrated can be used as a wattmeter.

When relay K11B and K14 are energized, the channel B network, which is identical to the channel A circuit except for reference designation, is used to couple the output of the power amplifier stage to the associated antenna.

#### 4.4 TRANSMITTER GAIN CONTROL CIRCUIT.

See figure 7-2. The level of power output from the linear power amplifier is controlled by limiting the level of signal input. Automatic control of the signal level from the associated exciter unit is accomplished by a biased rectifier circuit, which is referred to as the transmitter gain control (TGC) circuit. A small portion of the signal present in the anode circuit of the driver stage is coupled to the cathode element of one-half of dual triode V8. (The other half of the dual triode is used as a rectifier, and is part of the supply that develops a bias voltage for the first half). This cathode is biased positively. The amount of bias is determined by the setting of TGC adjustment R63. When the signal at the input to the linear power amplifier, hence on the anode of the driver stage, exceeds a certain level, V8 conducts on the negative signal peaks. The output of V8 is connected through relay K12 to either J2 or J3. (The contacts of relay K12 connect the output of the TGC circuit to J2 when the relay is deenergized and to J3 when the relay is energized). Relay K12 is energized when the CHANNEL A-CHANNEL B switch is in the CHANNEL B position.

During the time that the linear power amplifier is being tuned, the input amplifier and driver stages are operated at reduced plate and screen voltages. The signal level in the anode circuit of the driver amplifier stage will not be great enough to drive the power amplifier stage to a dangerous level, and will not be great enough to produce an output from the TGC circuit.

#### 4.5 METERING CIRCUITS.

See figure 7-2. Panel meters are provided to give a visual indication of: driver amplifier stage plate current, power amplifier V4 cathode current, power amplifier V5 cathode current, power amplifier stage grid current, r-f amplifier tuning, power amplifier stage screen current, power amplifier stage filament voltage, and power amplifier stage plate voltage. The panel meter that is labeled PLATE CURRENT is permanently connected into the power amplifier plate circuit, and continuously indicates the amount of current flowing in the power amplifier plate circuit. The meter that is labeled MULTIMETER is connected across a series of suitable shunt resistances and multipliers by an eight position wafer switch, which is also labeled MULTIMETER. The function of the MULTIMETER in each of the MULTIMETER switch positions is discussed in the following paragraphs.

In the DRIVER PLATE position of the MULTIMETER switch, the MULTIMETER is connected across R18, which is in the plate supply circuit of the driver amplifier stage. The value of the R18 is such that the scale of the MULTIMETER is 0 to 400 milliamperes.

SECTION IV  
Principles of Operation

When the LT PA CATH position of the MULTIMETER switch is selected. The MULTIMETER is connected across R36. R36 is electrically located in the cathode circuit of V4, and is of such a value that the scale of the MULTIMETER is 0 to 800 milliamperes.

The scale of the MULTIMETER is 0 to 800 milliamperes and the MULTIMETER is connected across R37 when the MULTIMETER switch is placed in the RT PA CATH position. R37 is in the cathode circuit of V5.

The MULTIMETER is connected across R49 in the PA GRID position of the MULTIMETER switch. The combined grid current from V4 and V5 flows through this resistor. The meter scale is 0 to 4 milliamperes when connected across this resistor.

The output of an r-f voltmeter circuit is connected to the MULTIMETER when the MULTIMETER switch is placed in the PA LOAD position. The voltmeter circuit is composed of C87, C88, CR14A, CR14B, L25, and L26, and R42. In the DR TUNE position of the DR TUNE-PA TUNE-OPERATE switch, the voltage at the arm of R42 is proportional to the level of r-f signal developed across the tuned circuit in the driver amplifier stage. In the PA TUNE and OPERATE positions of the DR TUNE-PA TUNE-OPERATE switch, the voltage at the arm of R42 is proportional to the difference of the level of r-f signals developed across the tuned circuits in the driver amplifier stage and in the output network. The voltage applied to the MULTIMETER is applied through R39 if the DR TUNE-PA TUNE-OPERATE switch is in the DR TUNE position. This resistor limits the applied voltage to a value that will not overdrive the meter movement. This position of the MULTIMETER switch is used in the tuning of the r-f amplifier stages. The tuned circuits of the input and driver amplifier stages are tuned for a maximum indication when the DR TUNE-PA TUNE-OPERATE switch is in the DR TUNE position. The output network is tuned for a minimum indication when the DR TUNE-PA TUNE-OPERATE switch is in the PA TUNE position.

Placing the MULTIMETER switch in the PA SCREEN position connects the MULTIMETER across R27, which is in the screen supply circuit to the power amplifier stage. The scale of the MULTIMETER in the PA SCREEN position of the MULTIMETER switch is 0 to 400 milliamperes.

3  
5  
1  
The same filament voltage that is applied to V5 is applied to the MULTIMETER through a voltage divider and rectifier circuit when the MULTIMETER switch is placed in the PA FIL VOLTS position. The actual voltage applied to the meter is determined by the setting of R45, which is used as a calibration adjustment, and is proportional to the applied filament voltage. The meter scale is 0 to 8 volts when properly calibrated.

The MULTIMETER is connected across R35 when the MULTIMETER switch is placed in the PA PLATE VOLTS position. R35 is one of a series of resistors (R30 through R35) that are connected between the positive end of the 2700-volt power supply and the negative end of the 300-volt power supply. The voltage applied to the meter is proportional to the 3000 volts developed between these two points. The meter scale in this position of the MULTIMETER switch is 0 to 4 kilovolts.

#### 4.6 CHANNEL SWITCHING CIRCUIT.

Channel switching is accomplished by relay action. Channel A circuits are in use in the energized position of the relays, and channel B circuits are in use when the relays are deenergized.

##### 4.6.1 LOCAL OPERATION WITH INTERNAL 120 V A-C.

When the linear power amplifier is connected for local operation only, the LOCAL-REMOTE switch must be in the LOCAL position for the channel switching circuits to function properly. In this mode of operation, terminal 2 of TB2 is grounded and terminal 3 of TB2 is jumpered to terminal 9 of TB2. This connects the power control voltage from the secondary of transformer T1 to the coil of relay K12, and the coil circuit of relay K12 is completed through the CHANNEL A-CHANNEL B switch. In the CHANNEL A position of this switch relay K12 is deenergized. The power control voltage is

## SECTION V Maintenance

applied through the contacts of relay K12 to the coil circuits of relays K9, K10, and K11-A. In the CHANNEL B position of the CHANNEL A-CHANNEL B switch, relay K12 is energized and the power control voltage is applied to the coil circuits of relay K11-B and K14. Another set of contacts on relay K12 switch the output of the transmitter gain control circuit.

### 4.6.2 REMOTE OPERATION.

When the 204F-1 is connected for remote operation, the channel switching circuit may be controlled by either the CHANNEL A-CHANNEL B switch or a similar switch in the remote control circuits. The channel switching circuits function as described in paragraph 4.6.1 when the LOCAL-REMOTE switch is in the LOCAL position. When the LOCAL-REMOTE switch is placed in the REMOTE position, a ground is provided for relay control voltage through terminal 5 of TB2, if channel B operation is desired. This ground, at terminal 5 of TB2, will cause relay K12 to energize.

### 4.7 KEYING RELAY CIRCUIT.

Plate and screen voltage is applied to the power amplifier stage of the linear power amplifier only when relay K7 is energized. One side of the coil of relay K7 is returned to ground through the DR TUNE-PA TUNE-OPERATE switch (when this switch is in the PA TUNE or OPERATE positions), resistors R72 and 73 in parallel, capacitor C109, inductor L16, directional coupler DC2, and the associated antenna system. The other side of the coil of relay K7 is brought to terminal 11 of TB2.

#### 4.7.1 LOCAL OPERATION.

See figure 7-1. When the 204F-1 is connected for local operation only, terminal 11 of TB2 is connected to terminal 9 of TB2. Terminal 9 of TB2 is connected to the secondary of transformer T1. Therefore, the power control voltage is connected to one side of relay K7. If the antenna system is properly connected, relay K7 will be energized when the DR TUNE-PA TUNE-OPERATE switch is placed in either the PA TUNE or OPERATE positions. A relay that is operated from the key line of the associated exciter unit may be inserted between terminals 9 and 11 of TB2. If so, the relay and the DR TUNE-PA TUNE-OPERATE switch are used together to control relay K7.

#### 4.7.2 REMOTE OPERATION.

See figure 7-4. When the linear power amplifier is connected for remote operation, the voltage to energize relay K7 originates in the remote control circuit. This voltage may or may not be connected through the contacts of a relay controlled from the keyline of the associated exciter unit. The DR TUNE-PA TUNE-OPERATE switch must be in the PA TUNE or OPERATE positions for the remote control voltage or keying relay to be effective.

## SECTION V

### MAINTENANCE

#### 5.1 GENERAL.

Maintenance of Linear Power Amplifier 204F-1 can best be performed by qualified persons who are familiar with the physical layout, method of operation and principles of operation of the equipment. Therefore, it is recommended that maintenance personnel be thoroughly familiar with the previous sections of this instruction book before any maintenance is attempted.

The locations of all component parts are shown in the parts identification illustrations of Section VI. Component reference designations are clearly marked on panels, walls, etc. adjacent to the actual components. The locations of components in the r-f compartment are shown in a diagram that is located on the rear surface of the upper cabinet door. It should be kept in mind at all times that the

3 2 2

equipment operates on voltages which are dangerous to life. Maintenance personnel should never depend on interlocks, but always use the high voltage shorting sticks that are furnished to determine that circuits are deenergized. Under no circumstances should maintenance personnel reach within the cabinet for the purpose of servicing or adjusting the equipment without the immediate presence or assistance of another person capable of rendering aid.

## 5.2 TEST EQUIPMENT.

The following items of test equipment are required to perform maintenance on the equipment.

- |                               |   |
|-------------------------------|---|
| a. VTVM                       | Hewlett-Packard Model 410B, or equivalent |
| b. Capacitive Voltage Divider | Hewlett-Packard 453A, or equivalent       |
| c. Precision A-C Voltmeter    | Weston Model 433, or equivalent           |
| d. Volt-Ohmmeter              | Triplett Model 630, or equivalent         |
| e. Probe T Connector          | Hewlett-Packard 455A, or equivalent       |

## 5.3 PREVENTIVE MAINTENANCE.

The faithful performance of the preventive maintenance procedures given in the following paragraphs will eliminate many costly repairs and reduce the time that the equipment is inoperative. It is assumed that the equipment is operated eight hours a day or more. If the equipment is operated less than eight hours a day, the following procedures should be performed as required.

### 5.3.1 DAILY INSPECTION-POWER NOT APPLIED.

The following steps should be performed daily, without power applied to the equipment.

- a. Observe that power is not applied to equipment. If necessary, depress the **FILAMENT OFF** pushbutton and then place the external disconnect switch in the **OFF** position.
- b. Open the upper cabinet door. Check the tightness of all connections on terminal boards TB2 and TB14.
- c. Check the tightness of connections to both meters mounted on the upper cabinet door.
- d. Check the tightness of the connections on power amplifier filament transformer T4.
- e. Check all connections to amplifier tubes for tightness and signs of overheating.
- f. Close the upper cabinet door and open the lower cabinet door.
- g. Inspect all transformer, relay, power contactor, etc. connections for tightness.
- h. Check that both high voltage rectifier tubes are firmly seated in their sockets and the anode caps are firmly in place.
- i. Inspect the air filter on the lower cabinet door. Clean, if dirty, as outlined in paragraph 5.3.8.
- j. Close the lower cabinet door.

SECTION V  
Maintenance

5.3.2 WEEKLY INSPECTION - POWER NOT APPLIED.

The following steps should be performed weekly, without power applied to the equipment.

- a. Perform all the steps outlined for a daily inspection with power removed.
- b. Clean interior and exterior of cabinet, either by wiping with a lintless cloth or blowing out dust with dry air under pressure. Special attention should be paid to the heat radiating fins on the power amplifier tubes.
- c. Inspect exposed contacts of all contactors and relays for excessive burning and pitting.
- d. Check the tightness of the connections at the blower motor terminal board. Rotate impeller slowly by hand to detect any bearing roughness.

5.3.3 MONTHLY INSPECTION - POWER NOT APPLIED.

The following steps should be performed monthly, without power applied to the equipment.

- a. Perform all the steps outlined for daily and weekly inspection with power removed.
- b. In addition to normal cleaning, clean the blower impeller blades, air ducts and power amplifier air chimneys.
- c. Inspect all wiring connections for tightness, and condition of all wiring and cabling.
- d. Inspect tightness of all mechanical fastenings, bolts, etc. including air duct fastenings.

5.3.4 DAILY INSPECTION - POWER APPLIED.

The following steps should be performed daily with power applied to the equipment.

- a. Perform all the steps outlined for daily inspection with power not applied.
- b. Place the MULTIMETER switch in the PA FIL VOLTS position.
- c. Place the LOCAL-REMOTE switch in the LOCAL position.
- d. Place the CHANNEL A-CHANNEL B switch in the CHANNEL A position.
- e. Place the DR TUNE-PA TUNE-OPERATE switch in the DR TUNE position.
- f. Determine that the associated exciter is not delivering an r-f signal to the linear power amplifier.
- g. Place the external disconnect switch in the ON position, and depress the FILAMENTS ON switch.
- h. Observe that the FILAMENTS indicator is lit and that the MULTIMETER is indicating exactly six volts. If necessary, adjust the PA FILAMENT control for the correct indication.
- i. Depress the FILAMENTS OFF switch, and observe that the FILAMENTS indicator is extinguished.

324



- j. Open the lower cabinet door, and block the lower door interlock switch in its closed position. Leave the cabinet door open.
- k. Place the MULTIMETER switch in the PA PLATE VOLTS position. Depress the PLATE ON switch.
- l. After the PLATE indicator lights, observe that the two high voltage rectifier tubes are glowing with uniform brightness and color. Further observe that the MULTIMETER is indicating approximately 3200 volts.
- m. Place the MULTIMETER switch in the DRIVER PLATE position, and the DR TUNE-PA TUNE-OPERATE switch in the OPERATE position.
- n. Observe that the MULTIMETER is indicating approximately 120 milliamperes.

NOTE

If the equipment is interconnected with a keying relay, the relay will have to be energized to obtain the proper indication for the following two steps.

- o. Place the MULTIMETER switch in the LT PA CATH position. Observe that the MULTIMETER is indicating exactly 250 milliamperes. Set the LEFT PA BIAS adjustment for a correct indication if necessary.
- p. Place the MULTIMETER switch in the RT PA CATH position. Observe that the MULTIMETER is indicating exactly 250 milliamperes. Set the RIGHT PA BIAS adjustment for a correct indication if necessary.
- q. Depress the PLATE OFF switch, wait approximately three minutes, then depress the FILAMENTS OFF switch.
- r. Place the external disconnect switch in the OFF position. Remove the blocking from the lower door interlock switch. Close the lower cabinet door.
- s. Restore the equipment to normal operation as described in Section III.

5.3.5 WEEKLY INSPECTION - POWER APPLIED.

The following steps should be performed weekly with power applied to the equipment.

- a. Perform all the steps outlined for daily inspection with power applied, but do not restore the equipment to normal operation as described in step s.
- b. Place the DR TUNE-PA TUNE-OPERATE switch in the DR TUNE position and the MULTIMETER switch in the PA LOAD position.
- c. Set the controls on the associated exciter unit so that a signal of the proper frequency (frequency to which channel A components are tuned) is supplied to the linear power amplifier.
- d. Depress the PLATE ON switch, and observe that the PLATE indicator lights within three minutes.
- e. After the PLATE indicator lights, adjust the CHANNEL A INPUT AMP TUNING control for a maximum indication on the MULTIMETER.

SECTION V  
Maintenance

- f. Adjust the CHANNEL A DRIVER TUNING control for a maximum indication on the MULTIMETER.
- g. Place the DR TUNE-PA TUNE-OPERATE switch in the PA TUNE position.

NOTE

If the equipment is interconnected with a keying relay, the relay must be energized to obtain the correct indication in the following steps.

- h. Adjust the CHANNEL A PA TUNE control for a dip in the indication on the MULTIMETER.
- i. Adjust the CHANNEL A PA LOAD control for a zero indication on the MULTIMETER.
- j. Repeat step h.
- k. Place the MULTIMETER switch in the PA SCREEN position, and the DR TUNE-PA TUNE-OPERATE switch in the OPERATE position.
- l. Increase the level of the r-f signal from the associated exciter unit to its normal amplitude. Observe that the MULTIMETER is indicating less than 80 milliamperes and that the PLATE CURRENT meter is indicating 1.5 amperes, or less.

NOTE

If the MULTIMETER or PLATE CURRENT meter indications exceed the values given, immediately depress the FILAMENTS OFF switch. Then check the setting of the TGC adjustment as described in paragraph 5.3.6.5.

- m. Place the DR TUNE-PA TUNE-OPERATE switch in the DR TUNE position, the MULTIMETER switch in the PA LOAD position, and the CHANNEL A-CHANNEL B switch in the CHANNEL B position.
- n. Set the controls on the associated exciter to produce a signal at the frequency to which the channel B circuits are tuned and of a normal amplitude.
- o. Adjust the CHANNEL B INPUT AMP TUNING control for a maximum indication on the MULTIMETER.
- p. Adjust the CHANNEL B DRIVER TUNING control for a maximum indication on the MULTIMETER.
- q. Place the DR TUNE-PA TUNE-OPERATE switch in the PA TUNE position.
- r. Adjust the CHANNEL B PA TUNE control for a dip in the indication on the MULTIMETER.
- s. Adjust the CHANNEL B PA LOAD control for a zero indication on the MULTIMETER.
- t. Place the MULTIMETER switch in the PA SCREEN position, and the DR TUNE-PA TUNE-OPERATE switch in the OPERATE position.
- u. Observe that the MULTIMETER is indicating less than 80 milliamperes and that the PLATE CURRENT meter is indicating 1.5 amperes, or less.
- v. Restore the equipment to normal operation as described in Section III.

326

**5.3.6 MONTHLY INSPECTION - POWER APPLIED.**

The operation of the thermal overload and plate overload circuits and the calibration of the multi-meter, r-f voltmeter, and TGC circuits should be checked at least once a month. Use the procedures outlined in the following paragraphs to perform these checks.

**5.3.6.1 THERMAL OVERLOAD CIRCUIT CHECK.** - Proceed to check the thermal overload circuit as follows:

- a. Place the external disconnect switch in the OFF position.
- b. Remove the two plates that cover the rear portion of the top of the cabinet. Connect a Weston Model 433 (0 to 15 and 0 to 30-volt scales) a-c voltmeter, or equivalent, between terminals 1 and 2 on TB13. Connect the meter for operation on the 0 to 30-volt scale.

**NOTE**

The terminals of TB13 are not numbered. Terminal 1 is the terminal that has a white wire with brown and orange tracers. Terminal 2 is the terminal with a white wire with black and green tracers.

- c. Place the MULTIMETER switch in the PA FIL VOLTS position.
- d. Place the LOCAL-REMOTE switch in the LOCAL position.
- e. Place the DR TUNE-PA TUNE-OPERATE switch in the DR TUNE position.
- f. Determine that the associated exciter is not delivering an r-f signal to the linear power amplifier.
- g. Place the external disconnect switch in the ON position, and depress the FILAMENTS ON switch.
- h. Observe that the FILAMENTS indicator is lit and that the MULTIMETER is indicating exactly six volts. If necessary, adjust the PA FILAMENT control for the correct indication.
- i. Depress the PLATE ON pushbutton. After the PLATE indicator is illuminated, set the OVERLOAD control for a reading of 23 volts on the meter.
- j. Place the MULTIMETER switch in the DRIVER PLATE position, and the DR TUNE-PA TUNE-OPERATE switch in the OPERATE position.
- k. Observe that the MULTIMETER is indicating approximately 120 milliamperes.

**NOTE**

If the equipment is interconnected with a keying relay, the relay will have to be energized to obtain the proper indication for the following steps.

- l. Place the MULTIMETER switch in the LT PA CATH position. Observe that the MULTIMETER is indicating exactly 250 milliamperes. Set the LEFT PA BIAS adjustment for a correct indication if necessary.
- m. Place the MULTIMETER switch in the RT PA CATH position. Observe that the MULTIMETER is indicating exactly 250 milliamperes. Set the RIGHT PA BIAS adjustment for a correct indication if necessary.

SECTION V  
Maintenance

n. Turn the RIGHT PA BIAS adjustment until the MULTIMETER is indicating 350 milliamperes. Place the MULTIMETER switch in the LT PA CATH position, and adjust the LEFT PA BIAS adjustment until the MULTIMETER is indicating 350 milliamperes. Within one minute, the thermal overload circuit will operate removing screen and plate voltage from V4 and V5. Operation of the overload circuit will be indicated by the PLATE indicator being extinguished.

NOTE

The setting of the OVERLOAD control is a function of ambient temperature. The adjustment for an indication of 23 volts applies only when the room temperature is 29 degrees C (84 degrees F ).

o. Turn both the LEFT PA BIAS and RIGHT PA BIAS controls counterclockwise. Depress the FILAMENTS OFF switch, and place the external disconnect switch in the OFF position.

p. Disconnect the voltmeter from TB13, and replace the two plates on the rear portion of the top of the cabinet.

q. Place the external disconnect switch in the ON position, and depress the PLATE ON switch.

r. Repeat steps l. and m.

s. Return the equipment to normal operation as described in section III.

5.3.6.2 PLATE OVERLOAD CIRCUIT CHECK - Proceed to check the plate overload circuit as follows:

a. Place the external disconnect switch in the OFF position. Open the upper cabinet door.

b. Disconnect the r-f feedback signal at C4 in the grid box. Accomplish this by removing the end of C4 that is attached to a mounting post, and by connecting this end of C4 to the grounding post provided. Close the upper cabinet door.

c. Place the MULTIMETER switch in the PA FIL VOLTS position.

d. Place the LOCAL-REMOTE switch in the LOCAL position.

e. Place the CHANNEL A-CHANNEL B switch in the CHANNEL A position.

f. Place the DR TUNE-PA TUNE-OPERATE switch in the DR TUNE position.

g. Determine that the associated exciter is not delivering an r-f signal to the linear power amplifier

h. Place the external disconnect switch in the ON position, and depress the FILAMENTS ON switch.

i. Observe that the FILAMENTS indicator is lit and that the MULTIMETER is indicating exactly six volts. If necessary, adjust the PA FILAMENT control for the correct indication.

j. Place the DR TUNE-PA TUNE-OPERATE switch in the PA TUNE position.

k. Depress the PLATE ON switch and observe that the PLATE indicator lights within three minutes.

325

l. Place the MULTIMETER switch in the LT PA CATH position. Observe that the MULTIMETER is indicating exactly 250 milliamperes. Set the LEFT PA BIAS adjustment for a correct indication if necessary.

NOTE

If the equipment is interconnected with a keying relay, the relay will have to be energized to obtain the proper indication in this and the following steps.

m. Place the MULTIMETER switch in the RT PA CATH position. Observe that the MULTIMETER is indicating exactly 250 milliamperes. Set the RIGHT PA BIAS adjustment for a correct indication if necessary.

o. Place the DR TUNE-PA TUNE-OPERATE switch in the DR TUNE position and the MULTIMETER switch in the PA LOAD position.

p. Set the controls on the associated exciter unit so that a signal of the proper frequency (frequency to which channel A components are tuned) is supplied to the linear power amplifier.

q. Adjust the CHANNEL A INPUT AMP TUNING control for a maximum indication on the MULTIMETER.

r. Adjust the CHANNEL A DRIVER TUNING control for a maximum indication on the MULTIMETER.

s. Place the DR TUNE-PA TUNE-OPERATE switch in the PA TUNE position.

t. Adjust the CHANNEL A PA TUNE control for a dip in the indication on the MULTIMETER.

u. Adjust the CHANNEL A PA LOAD control for a zero indication on the MULTIMETER.

v. Repeat step t.

w. Place the MULTIMETER switch in the PA SCREEN position, and the DR TUNE-PA TUNE-OPERATE switch in the OPERATE position.

x. Increase the level of the r-f signal from the associated exciter unit to its normal amplitude. Observe that the MULTIMETER is indicating less than 80 milliamperes and that the PLATE CURRENT meter is indicating 1.5 amperes, or less.

NOTE

If the MULTIMETER or PLATE CURRENT meter indications exceed the stated values, immediately depress the FILAMENTS OFF switch. Then check the setting of the TGC adjustment as described in paragraph 5. 3. 6. 5.

y. Increase the r-f signal level at the exciter until the plate overload circuit operates. Operation of the overload circuit, which is indicated by the PLATE indicator being extinguished, should occur when the PLATE CURRENT meter is indicating between 1.6 and 1.7 amperes.

CAUTION

Do not let the power amplifier screen current exceed 80 milliamperes. Reduce the amount of screen current with the CHANNEL A PA LOAD control if necessary.

**SECTION V**  
**Maintenance**

z. Depress the **FILAMENTS OFF** switch, place the external disconnect switch in the **OFF** position, and open the upper cabinet door.

aa. Disconnect C4 in the grid box from the grounding post and attach to its mounting post. Close the upper cabinet door.

ab. Restore the equipment to normal operation as described in Section III.

**5.3.6.3 MULTIMETER CALIBRATION - PA FILAMENT POSITION.** - Proceed to check the meter calibration circuit that determines the indication on the **MULTIMETER** when the **MULTI-METER** switch is in the **PA FIL VOLTS** position as follows:

a. Place the external disconnect switch in the **OFF** position, and open the upper cabinet door.

b. Open the lower cabinet door, and block the lower door interlock switch in the closed position.

c. Remove the two access hole cover plates that are located on the shelf that separates the grid compartment and power supply compartment.

d. Connect a Weston Model 433 (0 to 15 and 0 to 30-volt scales) a-c voltmeter, or equivalent, between terminals 7 and 8 of transformer T4. Connect the meter for operation on the 0 to 15-volt scale.

**NOTE**

The meter should be located outside of the cabinet. The meter leads extend through one of the access holes, through the power supply compartment, and out of the cabinet.

e. Place the **MULTIMETER** switch in the **PA FIL VOLTS** position. Close the upper cabinet door.

f. Place the external disconnect switch in the **ON** position, and depress the **FILAMENTS ON** switch. Observe that both the meter connected to transformer T4 and the **MULTIMETER** are indicating some voltage.

g. Turn the **PA FILAMENT** control until the meter connected to transformer T4 is indicating exactly six volts. Observe that the **MULTIMETER** is indicating exactly six volts.

**NOTE**

If the **MULTIMETER** does not indicate exactly six volts, adjust the R45, which is located on a mounting panel in the upper left corner of the power supply compartment until it does.

h. Depress the **FILAMENTS OFF** switch, and place the external disconnect switch in the **OFF** position.

i. Open the upper cabinet door, and disconnect the meter from transformer T4. Replace the two access hole cover plates that were removed in step d.

j. Remove the blocking from the lower door interlock switch.

k. Close both the upper and lower cabinet doors, and return the equipment to normal operation as described in Section III.

5.3.6.4 MULTIMETER CALIBRATION - PA LOAD POSITION. - Proceed to check the calibration of the r-f voltmeter circuit as follows:

- a. Place the external disconnect switch in the OFF position. Open the upper cabinet door.
- b. Disconnect the r-f feedback signal at C4 in the grid box. Accomplish this by removing the end of C4 that is attached to a mounting post, and by connecting this end of C4 to the grounding post provided. Close the upper cabinet door.
- c. Place the MULTIMETER switch in the PA FIL VOLTS position.
- d. Place the LOCAL-REMOTE switch in the LOCAL position.
- e. Place the CHANNEL A-CHANNEL B switch in the CHANNEL A position.
- f. Place the DR TUNE-PA TUNE-OPERATE switch in the DR TUNE position.
- g. Determine that the associated exciter is not delivering an r-f signal to the linear power amplifier.
- h. Place the external disconnect switch in the ON position, and depress the FILAMENTS ON switch.
- i. Observe that the FILAMENTS indicator is lit and that the MULTIMETER is indicating exactly six volts. If necessary, adjust the PA FILAMENT control for the correct indication.
- j. Place the DR TUNE-PA TUNE-OPERATE switch in the PA TUNE position.
- k. Depress the PLATE ON switch and observe that the PLATE indicator lights within three minutes.
- l. Place the MULTIMETER switch in the LT PA CATH position. Observe that the MULTIMETER is indicating exactly 250 milliamperes. Set the LEFT PA BIAS adjustment for a correct indication if necessary.

NOTE

If the equipment is interconnected with a keying relay, the relay will have to be energized to obtain the proper indication in this and the following steps.

- m. Place the MULTIMETER switch in the RT PA CATH position. Observe that the MULTIMETER is indicating exactly 250 milliamperes. Set the RIGHT PA BIAS adjustment for a correct indication if necessary.
- o. Place the DR TUNE-PA TUNE-OPERATE switch in the DR TUNE position and the MULTIMETER switch in the PA LOAD position.
- p. Set the controls on the associated exciter unit so that a signal of the proper frequency (frequency to which channel A components are tuned) is supplied to the linear power amplifier.
- q. Adjust the r-f signal level at the exciter until the indication on the MULTIMETER is approximately one-third of full scale.

SECTION V  
Maintenance

- r. Adjust the CHANNEL A INPUT AMP TUNING control for a maximum indication on the MULTIMETER.
- s. Adjust the CHANNEL A DRIVER TUNING control for a maximum indication on the MULTIMETER.
- t. Place the DR TUNE-PA TUNE-OPERATE switch in the PA TUNE position.
- u. Adjust the CHANNEL A PA TUNE control for a dip in the indication on the MULTIMETER.
- v. Adjust the CHANNEL A PA LOAD control for a zero indication on the MULTIMETER.
- w. Place the DR TUNE-PA TUNE-OPERATE switch in the OPERATE position.
- x. Increase the r-f signal level at the exciter until the PLATE CURRENT meter is indicating 0.8 amperes.
- y. Place the MULTIMETER switch first in the LT PA CATH position and then in the RT PA CATH position. If the indications on the MULTIMETER are not approximately equal, adjust the PA GD BAL control until the currents are in balance.
- z. Alternately place the MULTIMETER switch in the PA LOAD and PA SCREEN positions and increase the r-f signal at the exciter unit. Keep adjusting the CHANNEL A PA TUNE control for a dip as indicated on the MULTIMETER and monitoring the power amplifier screen current as the r-f signal is increased. If necessary, adjust the CHANNEL A PA LOAD control to maintain the power amplifier screen current at a maximum of 75 milliamperes. Increase the r-f signal level until the PLATE CURRENT meter is indicating 1.45 amperes.
- aa. Place the MULTIMETER switch in the PA LOAD position. Observe that the needle on the MULTIMETER is indicating exactly zero.
- ab. If the MULTIMETER indication is not correct, adjust R42 until the proper indication is obtained.

NOTE

R42 is located in the grid box, and cannot be adjusted with power applied. To make this adjustment: deenergize the equipment, open the upper cabinet door, turn the adjustment slightly in one direction, reenergize the equipment, and observe the effect. Repeat this procedure until the proper indication is obtained.

- ac. Depress the PLATE OFF switch, wait approximately three minutes, then depress the FILAMENTS OFF switch.
  - ad. Place the external disconnect switch in the OFF position. Open the upper cabinet door.
  - ae. Disconnect C4 from the grounding post and attach to its mounting post. Close the upper cabinet door, and restore equipment to normal operation as described in Section III.
- 5.3.6.5 TGC CIRCUIT CALIBRATION. - Proceed to check the calibration of the TGC circuit as follows:

- a. Place the external disconnect switch in the OFF position.
- b. Insert a probe T connector (Hewlett-Packard 455A or equivalent) in series with the transmission line that is connected to DC2.



SECTION V  
Maintenance

c. Disconnect the coaxial cable that couples the TGC signal to the channel A frequency source at the r-f signal source. Connect a dummy load, which consists of a one megohm resistor and a one microfarad capacitor in parallel, across the cable terminals. Connect a Hewlett-Packard Model 410B, or equivalent, vacuum tube voltmeter across the dummy load. Connect the meter to read a negative voltage of greater than ten volts.

d. Connect a single-tone, audio signal to the input of the associated exciter unit. Set the exciter unit controls to produce a single sideband signal at the frequency to which the channel A circuits are tuned.

e. Connect a Hewlett-Packard Model 410B vacuum tube voltmeter that is equipped with a Hewlett-Packard 453A capacitive voltage divider, or equivalent, to the probe T connector. Set the meter to read an a-c voltage of greater than 35 volts.

NOTE

The meter will be used to measure a voltage of approximately 355 volts, but the capacitive voltage divider provides a ten-to-one step-down ratio.

f. Open the upper cabinet door. Disconnect the r-f feedback signal at C4 in the grid box. Accomplish this by removing the end of C4 that is attached to a mounting post, and by connecting this end of C4 to the grounding post provided. Close the upper cabinet door.

g. Place the MULTIMETER switch in the PA FIL VOLTS position.

h. Place the LOCAL-REMOTE switch in the LOCAL position.

i. Place the CHANNEL A-CHANNEL B switch in the CHANNEL A position.

j. Place the DR TUNE-PA TUNE-OPERATE switch in the DR TUNE position.

k. Determine that the associated exciter is not delivering an r-f signal to the linear power amplifier.

l. Place the external disconnect switch in the ON position, and depress the FILAMENTS ON switch.

m. Observe that the FILAMENTS indicator is lit and that the MULTIMETER is indicating exactly six volts. If necessary, adjust the PA FILAMENT control for the correct indication.

n. Depress the PLATE ON switch, and observe that the PLATE indicator lights within three minutes.

o. Place the MULTIMETER switch in the DRIVER PLATE position, and the DR TUNE-PA TUNE-OPERATE switch in the OPERATE position.

p. Observe that the MULTIMETER is indicating approximately 120 milliamperes.

NOTE

If the equipment is interconnected with a keying relay, the relay will have to be energized to obtain the proper indication for the following steps.

**SECTION V**  
**Maintenance**

- q. Place the MULTIMETER switch in the LT PA CATH position. Observe that the MULTIMETER is indicating exactly 250 milliamperes. Set the LEFT PA BIAS adjustment for a correct indication if necessary.
- r. Place the MULTIMETER switch in the RT PA CATH position. Observe that the MULTIMETER is indicating exactly 250 milliamperes. Set the RIGHT PA BIAS adjustment for a correct indication if necessary.
- s. Place the DR TUNE-PA TUNE-OPERATE switch in the DR TUNE position.
- t. Set the controls on the associated exciter unit so that a signal of the proper frequency (frequency to which channel A components are tuned) is supplied to the linear power amplifier.
- u. Adjust the CHANNEL A INPUT AMP TUNING control for a maximum indication on the MULTIMETER.
- v. Adjust the CHANNEL A DRIVER TUNING control for a maximum indication on the MULTIMETER.
- w. Place the DR TUNE-PA TUNE-OPERATE switch in the PA TUNE position.
- x. Adjust the CHANNEL A PA TUNE control for a dip in the indication on the MULTIMETER.
- y. Adjust the CHANNEL A PA LOAD control for a zero indication on the MULTIMETER.  
Repeat step x.
- z. Place the DR TUNE-PA TUNE-OPERATE switch in the OPERATE position.
  - aa. Increase the audio signal level of the input to the exciter until the vtm that is connected to the T connector gives an indication of 35.5 volts. Observe that the other voltmeter is indicating exactly -10 volts d-c. If the voltmeter is not indicating exactly -10 volts, turn the TGC adjustment until the meter does indicate the correct voltage.
  - ab. Reduce the level of the audio signal to the exciter until the voltmeter that is connected to the T connector is indicating 31.6 volts. Observe that the other voltmeter indicates less than 0.3 volts d-c.
  - ac. Depress the PLATE OFF switch, wait approximately three minutes, and depress the FILAMENTS OFF switch. Place the external disconnect switch in the OFF position.
  - ad. Disconnect the voltmeter from the dummy load.
  - ae. Disconnect the dummy load from the coaxial cable, and reconnect the cable to the associated exciter unit.
  - af. Disconnect the voltmeter from the T connector, and remove the T connector from the output transmission line.
  - ag. Open the upper cabinet door. Disconnect C4 in the grid box from the grounding post and attach to its mounting post. Close the upper cabinet door.
  - ah. Restore the equipment to normal operation as described in Section III.

### 5.3.7 LUBRICATION.

Depending on use of the transmitter, lubrication of moving parts such as door hinges, tuning shafts and gears, will be necessary at various intervals. Hinges and shaft bearings may be lubricated with any good light oil, preferably one with rust inhibiting properties. Gears should be lubricated with a small amount of general purpose grease. Avoid excessive lubrication of these miscellaneous parts to minimize dust collection.

### 5.3.8 FILTER CLEANING PROCEDURE.

Under the normal operating conditions the filter on the linear power amplifier should be cleaned approximately every 30 days. To clean the filter proceed as follows:

a. Remove the filter and immerse in cool clean water. If it is impossible to immerse the filter, accumulation may be washed by using a fine spray of water passed through the filter in the direction opposite that of the air-flow arrows.

#### CAUTION

Do not direct a high velocity stream of water against the filter.  
Do not disturb the normal distribution of the shredded material in the filter.

b. Gently shake water out of the filter and replace in the blower with the air-flow arrows pointing in the direction of air circulation.

### 5.4 CORRECTIVE MAINTENANCE.

The need for corrective maintenance is evidenced by the failure of the 204F-1 to perform normally. Inasmuch as the linear power amplifier is part of a system, it must be determined that the 204F-1 is at fault and not some item of associated equipment. When this has been determined as described in the system instruction book, proceed to isolate the trouble and replace the faulty components as described in the following paragraphs.

#### 5.4.1 FAULT ISOLATION.

Most troubles can be isolated by observing and properly analyzing: (1) the response, or lack thereof, of equipment indicators to the action of equipment controls; (2) equipment meter readings; and (3) condition of circuit breakers and fuses. Therefore, it is recommended that the procedural test outlined in table 5-1 be performed. If the desired indication is obtained, proceed to the next procedural step. If the desired indication is not obtained, refer to figures 7-1 and 7-2 and perform logical circuit tracing in the area of the possible fault. Before starting the procedural test outlined in table 5-1, determine that the external disconnect switch is in the OFF position, the LOCAL-REMOTE switch is in the LOCAL position, the CHANNEL A-CHANNEL B switch is in the CHANNEL A position, the DR TUNE-PA TUNE-OPERATE switch is in the DR TUNE position, the MULTI-METER switch is in the PA FIL VOLTS position, the keying relay (if connected to terminal 11 of TB2) is energized, the channel selector switch at the remote location (if the equipment is connected for remote operation) is in the channel B position, and the associated exciter unit is not supplying an r-f signal to the linear power amplifier.

#### 5.4.2 COMPONENT REPLACEMENT.

Once a fault has been traced to a component, the faulty component must be removed from the cabinet without damage to any adjacent components, and a new component of the proper type installed. The majority of components are accessible by merely opening the upper cabinet door, opening the lower cabinet door, or by removing the cover plates on the top of the cabinet. Some components are

SECTION V  
Maintenance

accessible only after the grid box is removed from the cabinet. This is accomplished by removing six twist-lock screws and pulling the grid box straight forward out of the cabinet. However, the knob on the MULTIMETER switch must be removed before the grid box is pulled outward, and a coaxial cable disconnected before the grid box can be completely removed from the cabinet. Other components are accessible only after the two power amplifier tubes are removed. Reference to the parts in identification illustrations of Section VI will assist in the location of a given component. It is recommended that all wires be tagged before removal from a component so that they may be easily replaced on the new component. Replacement components shall be of the type specified in Section VI.

TABLE 5-1. LINEAR POWER AMPLIFIER 204F-1, FAULT ISOLATION TEST PROCEDURE

STEP	CONTROL SETTING AND INSTRUCTION	NORMAL INDICATION	POSSIBLE FAULT
1	Place external disconnect switch in ON position. Depress FILAMENTS ON switch.	FILAMENTS indicator lit.	Check source of power, fuses in disconnect switch, fuse F1, indicator lamp DS1, air chimney and door interlock switches, and relay K1.
2	Observe MULTIMETER in PA FILAMENT position.	Meter indicates exactly six volts.	Set to correct voltage with PA FILAMENTS control. Check blower, fuses F3 and F4, air interlock switch S6, and meter M2.
3	Depress PLATE ON switch.	PLATE indicator lights in approximately three minutes.	Check circuit breaker CB1, thermal switch S5, relays K3 and K8, time delay relay K2, and indicator lamp DS2.
4	Place MULTIMETER switch in PA PLATE VOLTS position.	MULTIMETER indicates approximately 3200 volts.	Check relays K4 and K6, fuse F5, and high voltage power supply circuit.
5	Place MULTIMETER switch in DRIVER PLATE position. Place DR TUNE-PA TUNE-OPERATE switch in OPERATE position.	MULTIMETER indicates approximately 120 ma.	Check V2 and V3. Also check 300-volt power supply.
6	Place MULTIMETER switch in LT PA CATH position.	MULTIMETER indicates exactly 250 ma.	Check setting of LEFT PA BIAS adjustment. Set for proper indication if necessary.

336

TABLE 5-1. LINEAR POWER AMPLIFIER 204F-1, FAULT ISOLATION TEST PROCEDURE (Cont)

STEP	CONTROL SETTING AND INSTRUCTION	NORMAL INDICATION	POSSIBLE FAULT
7	Place MULTIMETER switch in RT PA CATH position.	MULTIMETER indicates exactly 250 ma.	Check setting of RIGHT PA BIAS adjustment. Set for proper indication if necessary.
8	Place MULTIMETER switch in PA PA GRID position.	MULTIMETER indicates zero ma.	Check V4 and V5.
9	Place MULTIMETER switch in PA SCREEN position.	MULTIMETER indicates zero ma.	Check V4 and V5.
10	Place DR TUNE-PA TUNE-OPERATE switch in DR TUNE position. Place MULTIMETER switch in PA LOAD position. Set exciter for channel A frequency and increase level.	MULTIMETER indication directly proportional to r-f signal input.	Check signal input cable, input amplifier and driver amplifier circuits.
11	Rock CHANNEL A INPUT AMP TUNING control.	MULTIMETER indication decreases as control is moved either side of setting.	Check tuning of input amplifier stage.
12	Rock CHANNEL A DRIVER TUNING control.	MULTIMETER indication decreases as control is moved either side of setting.	Check tuning of driver amplifier stage.
13	Place the DR TUNE-PA TUNE-OPERATE switch in the PA TUNE position. Rock the CHANNEL A PA TUNE control.	MULTIMETER indication increases either side of setting.	Check tuning of output network.
14	Rock the CHANNEL A PA LOAD control.	MULTIMETER indication increases either side of setting.	Check tuning of output network.
15	Place the DR TUNE-PA TUNE-OPERATE switch in the OPERATE position. And the MULTIMETER switch in the PA SCREEN position. Increase the r-f signal level until the PLATE CURRENT meter is indicating 1.45 amperes.	MULTIMETER indication does not exceed 75 ma.	Check setting of TGC adjustment. See paragraph 5.3.6.5.
16	Place DR TUNE-PA TUNE-OPERATE switch in DR TUNE position, MULTIMETER switch in PA LOAD position, and CHANNEL A-CHANNEL B switch in the CHANNEL B POSITION. Reduce signal level at exciter. Set exciter for channel B frequency and increase level.	MULTIMETER indication directly proportional to r-f signal input.	Check signal input cable, input amplifier and driver amplifier circuits.

SECTION V  
Maintenance

TABLE 5-1. LINEAR POWER AMPLIFIER 204F-1, FAULT ISOLATION TEST PROCEDURE (Cont)

STEP	CONTROL SETTING AND INSTRUCTION	NORMAL INDICATION	POSSIBLE FAULT
17	Rock CHANNEL B INPUT AMP TUNING control.	MULTIMETER indication decreases as control is moved either side of setting.	Check tuning of input amplifier stage.
18	Rock CHANNEL B DRIVER TUNING control.	MULTIMETER indication decreases as control is moved either side of setting.	Check tuning of driver stage.
19	Place the DR TUNE-PA TUNE-OPERATE switch in the PA TUNE position. Rock the CHANNEL B PA TUNE control.	MULTIMETER indication increases either side of setting.	Check tuning of output network.
20	Rock the CHANNEL B PA LOAD control.	MULTIMETER indication increases either side of setting.	Check tuning of output network.

331

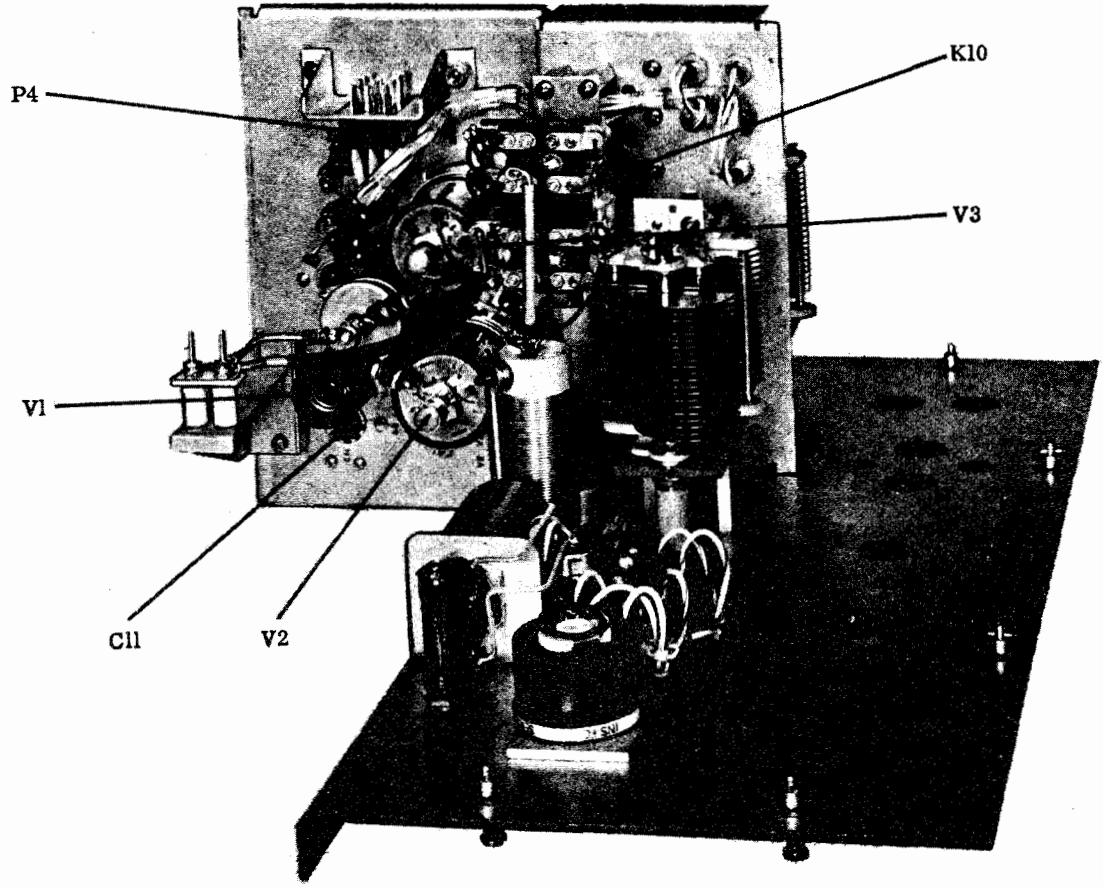
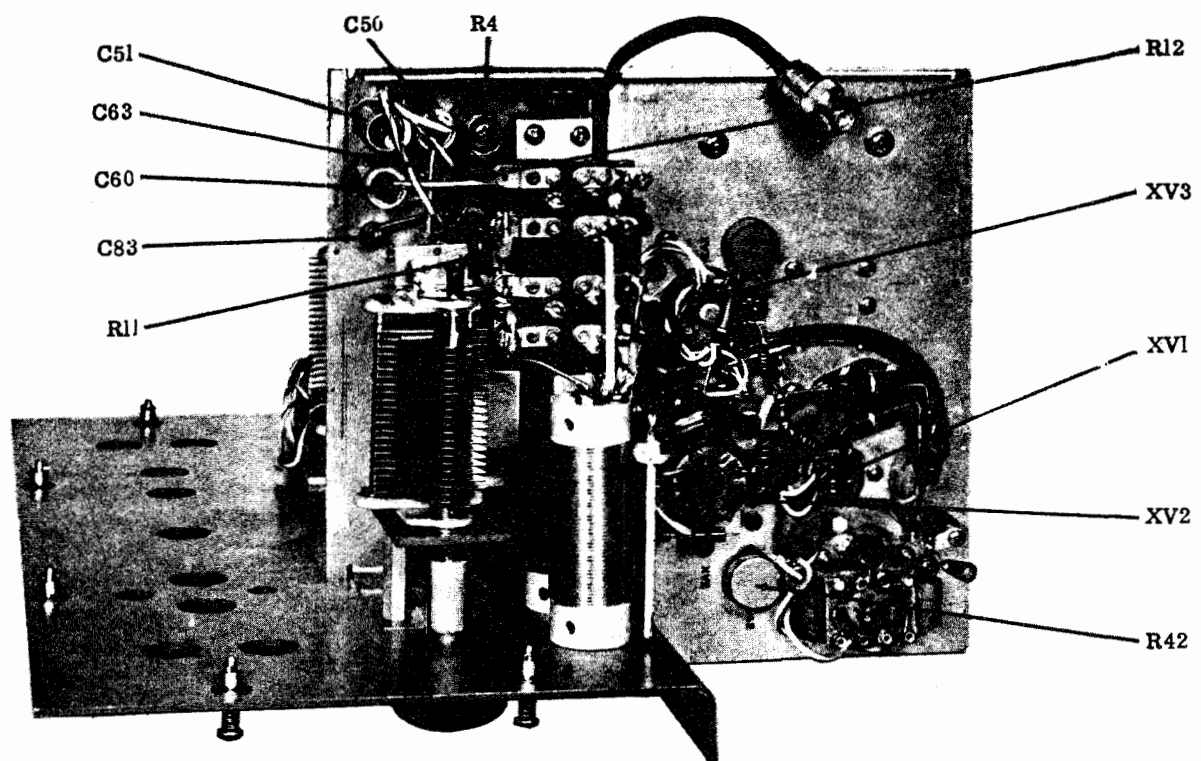

339

Figure 6-1. Grid Box, Parts Identification

SECTION VI  
Parts List

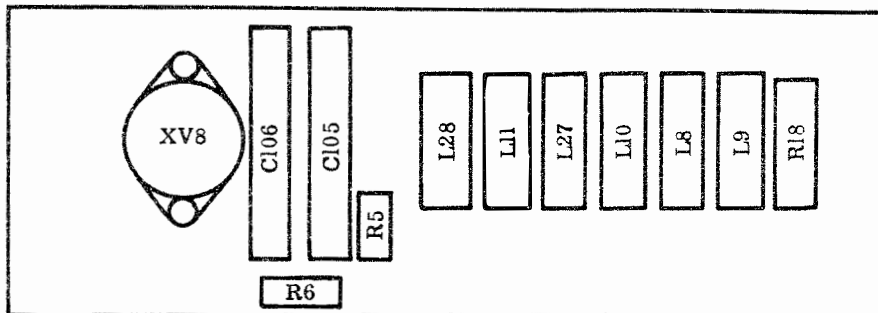

BOTTOM VIEW TB10

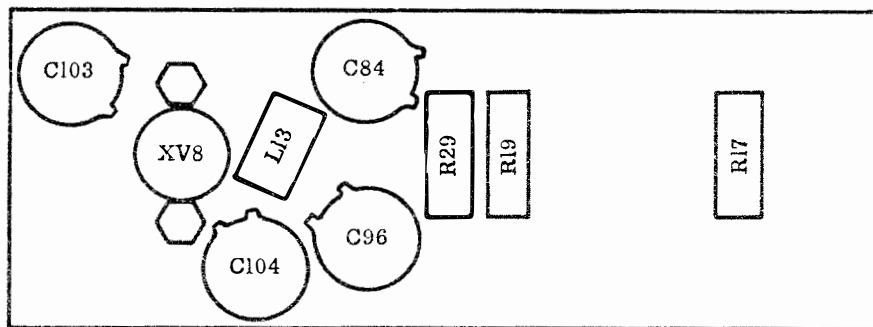

TOP VIEW TB10

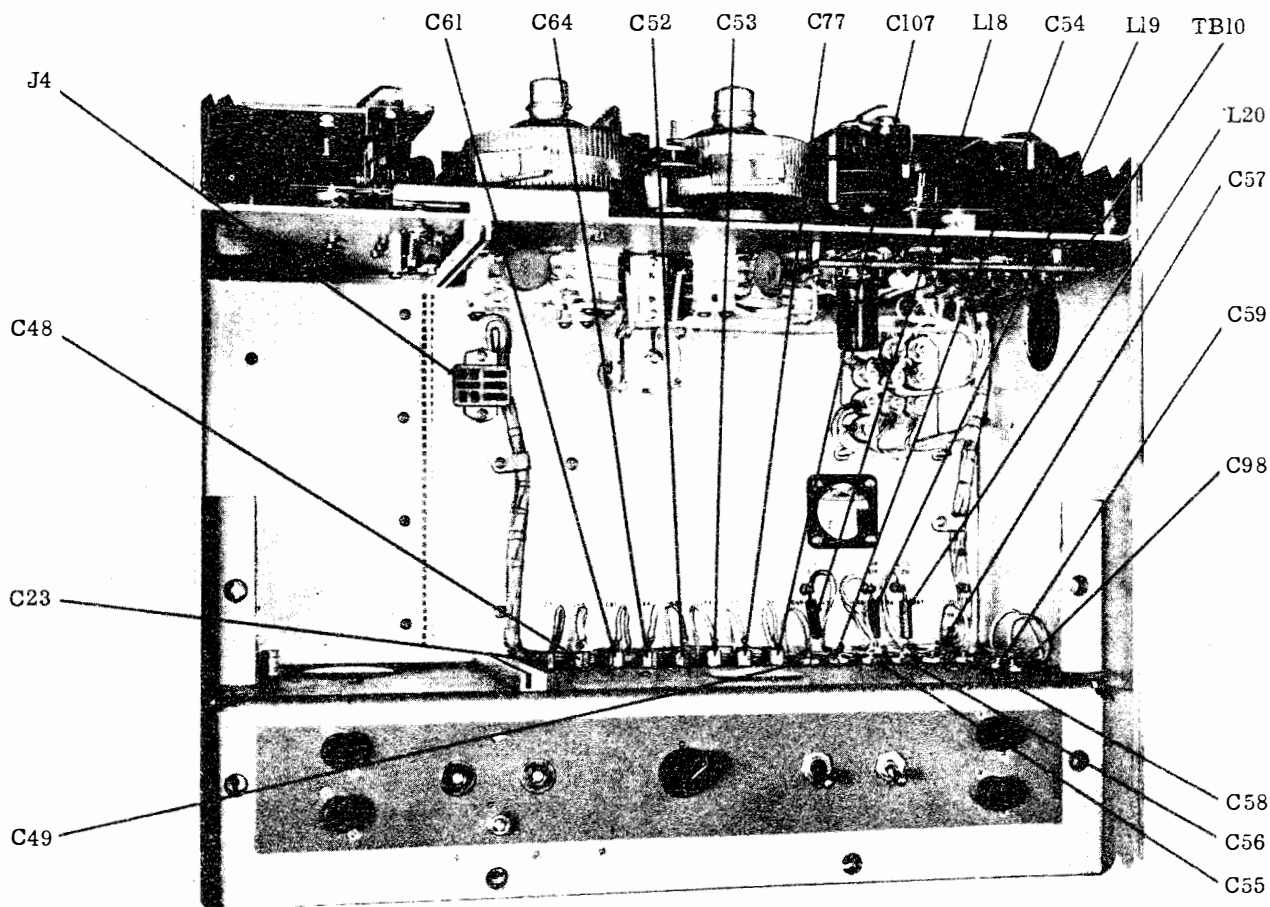

Figure 6-2. Grid Compartment, Parts Identification

310



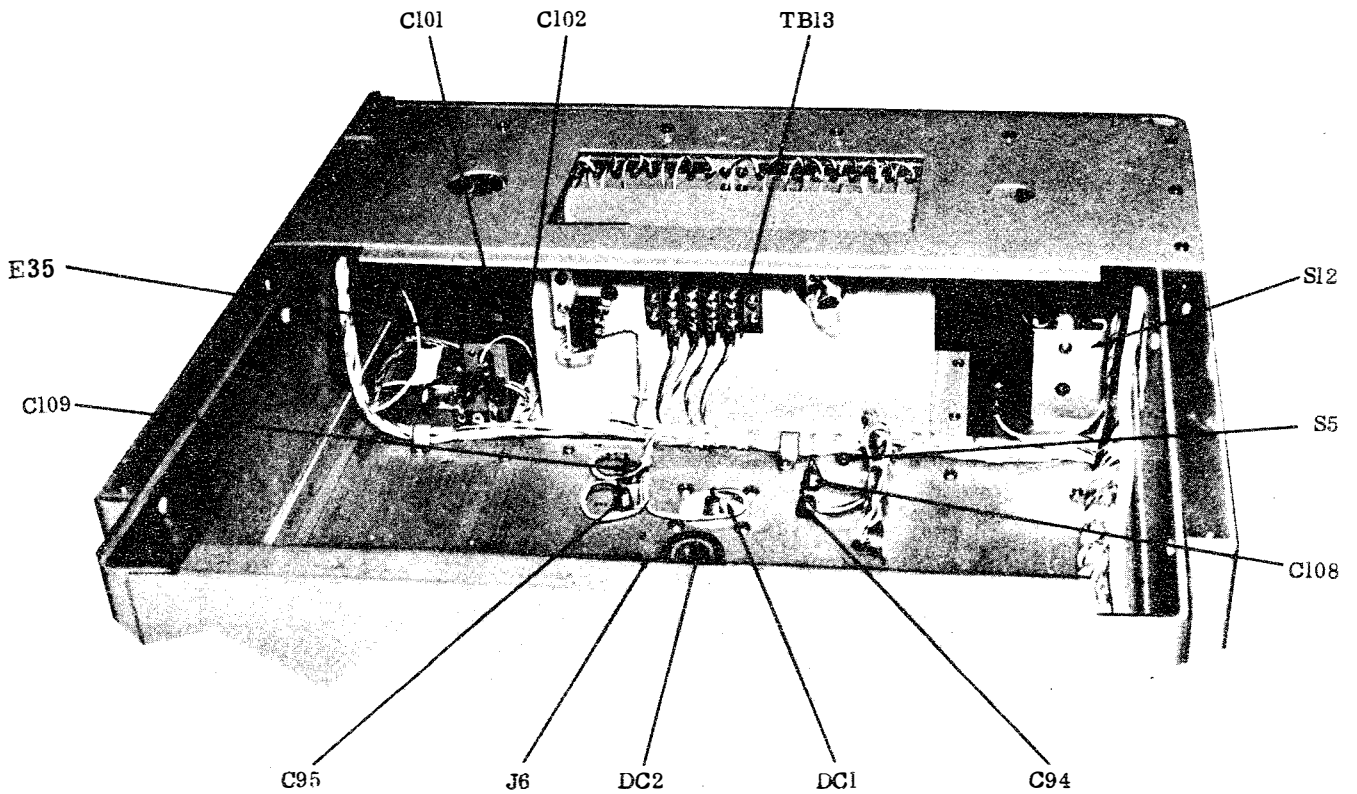
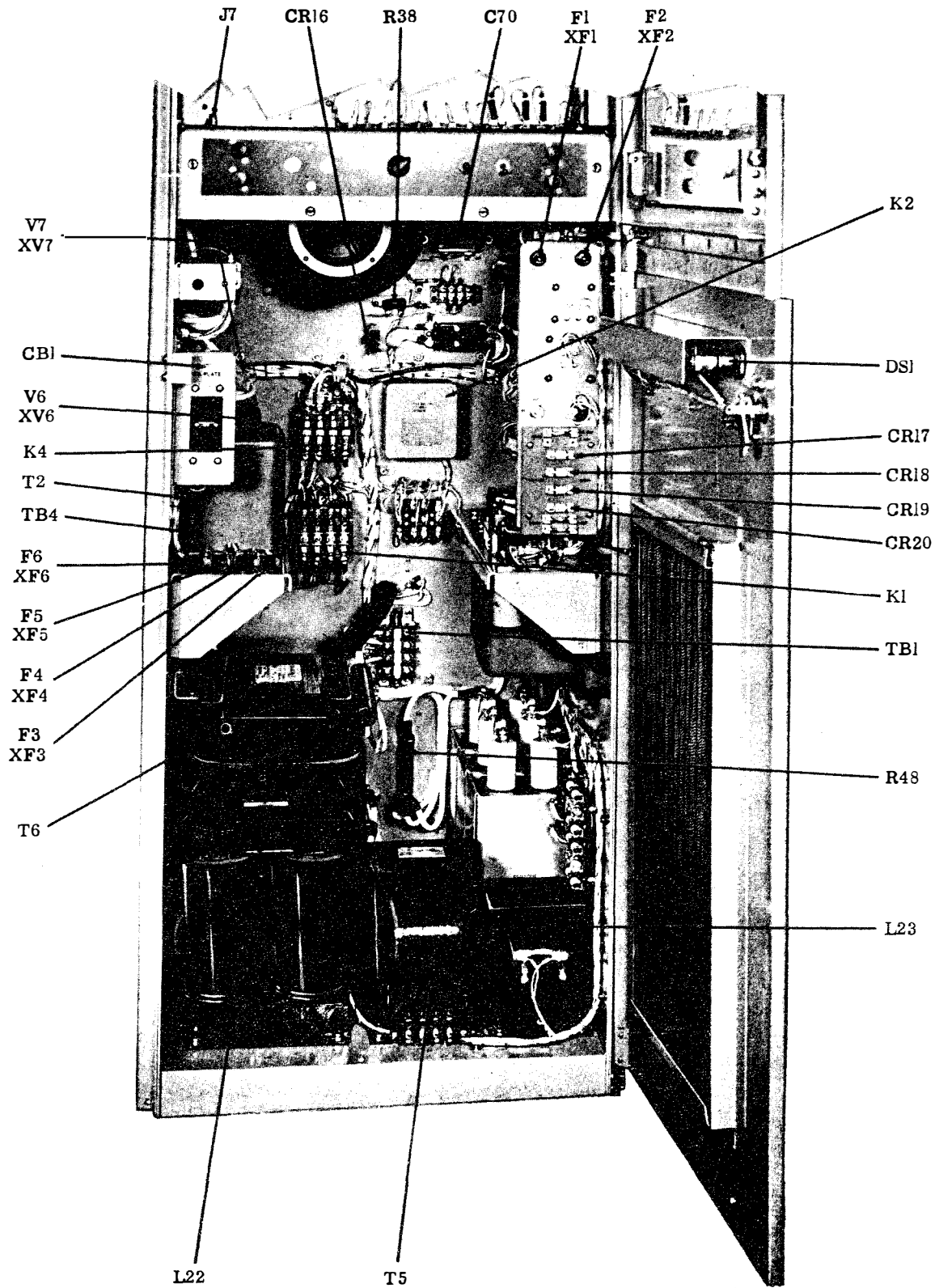

Figure 6-3. Input-Output Compartment, Parts Identification

Revised 1 October 1959

**SECTION VI**  
**Parts List**



**Figure 6-4. Power Supply Compartment, Parts Identification**

SECTION VI  
Parts List

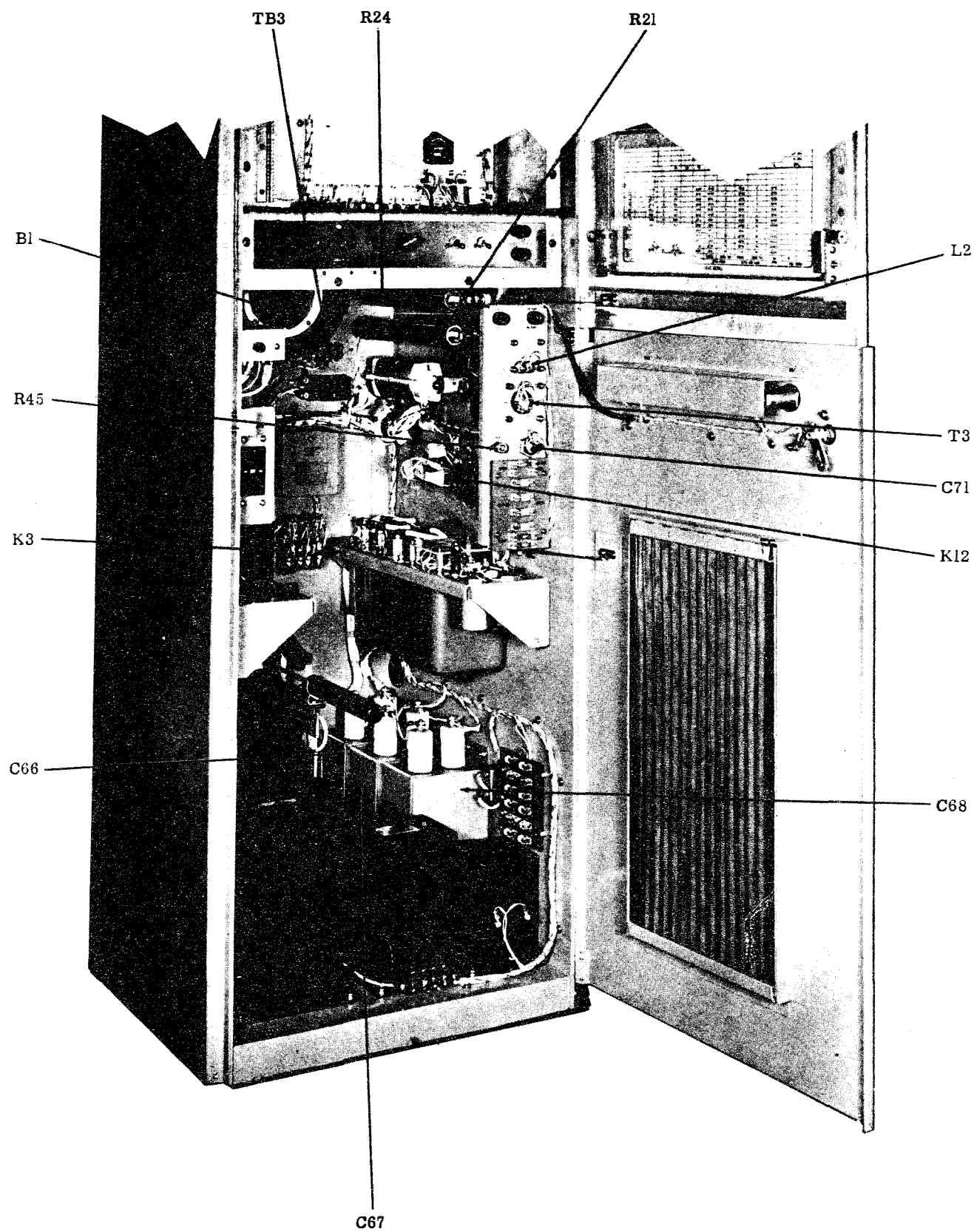

Figure 6-5. Power Supply Compartment, Parts Identification



## Linear Power Amplifier 204F-1

ITEM	DESCRIPTION	COLLINS PART NUMBER	ITEM	DESCRIPTION	COLLINS PART NUMBER
LINEAR POWER AMPLIFIER 204F-1 Single Input and Output		522 1130 00	C54	Same as C49	
B1	BLOWER ASSEMBLY, CENTRIFUGAL: Input Voltage, 230 VAC; Input Current 0.37 amp; Speed, 3350 rpm	009 1402 00	C60		
C1	CAPACITOR, FIXED, MICA: 0.001 uuf, ±10%; 1600 vdcw	912 2055 00	C61	Same as C23	
C2	CAPACITOR, FABRICATED UNIT: Consists of Following: CAPACITOR, FEEDBACK, ADJUST BRACKET, FEEDBACK CAPACITOR CAPACITOR, FEEDBACK	544 5820 002 544 5828 002 544 5920 002	C62	CAPACITOR, FIXED, CERAMIC: 0.002 uf, ±20%; 6000 vdcw	913 3540 00
C3	CAPACITOR, FIXED, CERAMIC: 0.005 uf, +100 -20%; 500 vdcw	913 1187 00	C63	CAPACITOR, FIXED, CERAMIC: 0.001 uf, +80 -20%; 500 vdcw	913 1292 00
C4	Same as C3		C64	Same as C23	
C5	CAPACITOR, FIXED, CERAMIC: 0.02 uf, +100 -20%; 500 vdcw	913 2142 00	C65	CAPACITOR, FIXED, FILM: 0.2 uf, ±10%; 7500 vdcw	933 0085 00
C6	CAPACITOR, VARIABLE, AIR: 13 - 320 uuf, No. Plates 43 per Section	921 0141 00	C66	CAPACITOR, FIXED, PAPER: 4 uf, ±10%; 4000 vdcw	962 4216 00
C7	Same as C6		C67	Same as C66	
C8	Same as C3		C68	Same as C66	
C9	CAPACITOR, FIXED, MICA: 0.001 uf, ±10%, 1000 vdcw	912 2055 00	C69	CAPACITOR, FIXED, GLASS: 100 uf, 55%; 350 vdcw	183 1801 00
C10	CAPACITOR, FABRICATED UNIT:	544 5740 00	C70	CAPACITOR, FIXED, PAPER: 4 uf, ±20%; 600 vdcw	962 4007 00
C11	CAPACITOR, FIXED, MICA: 100 uuf, ±20%; 500 vdcw	912 3602 00	C71	Same as C69	
C12	CAPACITOR, FIXED, CERAMIC: 2 uuf, ±1/4 uuf; 500 vdcw	916 0075 00	C72	Same as C69	
C13	Same as C5		C73	CAPACITOR, FIXED, ELECTROLYTIC: 200 uuf, 55%; 100 vdcw	183 1802 00
C14	Same as C6		C74	CAPACITOR, FIXED, FILM: 0.1 uf, ±10%; 7500 vdcw	933 0084 00
C15	Same as C6		C75	Same as C23	
C16	CAPACITOR, VARIABLE, AIR: 4.6 - 51 uuf; No. Plates 19	922 0080 00	C76	Same as C5	
C17	CAPACITOR, FIXED, CERAMIC: 1000 uuf, ±20%; 2500 vdcw	913 3508 00	C77	Same as C23	
C18	CAPACITOR, FABRICATED UNIT: Consists of Following: CAPACITOR-NEUT, ADJUST PLATE - CAPACITOR, COUNTERSUNK	544 5819 002 544 5916 002	C78	Same as C5	
C19	Same as C5		C79	Same as C5	
C20	NOT USED		C80	Same as C5	
C21	Same as C5		C81	Same as C5	
C22	NOT USED		C82	Same as C5	
C23	CAPACITOR, FIXED, CERAMIC: 0.001 uf, +80 -20%; 500 vdcw	913 1292 00	C83	Same as C63	
C24	NOT USED		C84	Same as C5	
C25	CAPACITOR, FIXED, CERAMIC: 6800 uuf, -20 +40%; 3.5 KV	913 3612 00	C85	Same as C5	
C26	CAPACITOR, VARIABLE, AIR: 35 - 140 uuf; No. Plates 23 per Section	921 0013 00	C86	Same as C69	
C27	Same as C26		C87	Same as C3	
C28	CAPACITOR, FIXED, CERAMIC: 47 uuf, ±5%; 5000 vdcw	913 0827 00	C88	Same as C3	
C29	CAPACITOR, FIXED, CERAMIC: 75 uuf, ±5%; 5000 vdcw	913 0830 00	C89	Same as C29	
C30	Same as C29		C90	Same as C29	
C31	Same as C29		C91	Same as C29	
C32	Same as C29		C92	Same as C35	
C33	Same as C28		C93	CAPACITOR, FIXED, CERAMIC: 0.5 uf, ±2%; 500 vdcw	916 5312 00
C34	Same as C29		C94	Same as C23	
C35	CAPACITOR, FIXED, CERAMIC: 25 uuf, ±5%; 2500 vdcw	913 4253 00	C95	Same as C23	
C36	Same as C29		C96	Same as C23	
C37	Same as C29		C97	CAPACITOR, FIXED, ELECTROLYTIC: 25 uf, -0 +100%; 50 vdcw	183 1356 00
C38	Same as C35		C98	Same as C49	
C39	Same as C29		C99	CAPACITOR, FIXED, CERAMIC: 68 uuf, ±1%; 500 vdcw	916 5314 00
C40	CAPACITOR, VARIABLE, AIR: 100 - 950 uuf, Air Gap, 0.075	920 0139 00	C100	Same as C99	
C41	CAPACITOR, VARIABLE, AIR: 80 - 930 uuf, No. Plates 71 per Section	920 0142 00	C101	Same as C23	
C42	CAPACITOR, FIXED, GLASS: 800 uuf, ±5%; 2000 vdcw	914 0702 00	C102	Same as C23	
C43	Same as C42		C103	Same as C84	
C44	CAPACITOR, FIXED, GLASS: 1600 uuf, ±5%; 2000 vdcw	914 0703 00	C104	Same as C84	
C45	Same as C44		C105	CAPACITOR, FIXED, ELECTROLYTIC: 10 uf, -0 +100%; 150 vdcw	183 1358 00
C46	Same as C29		C106	Same as C105	
C47	Same as C35		C107	Same as C23	
C48	Same as C23		C108	CAPACITOR, FIXED, CERAMIC: 1000 uuf +80% -20%; 500 vdcw	913 1292 00
C49	CAPACITOR, FIXED, PAPER: 0.10 uf, ±20%; 500 vdcw	241 0090 00	C109	Same as C23	
C50	Same as C49		CB1	CIRCUIT BREAKER: Trip Rating, 25 amp AC; Max Operating Voltage, 230 vdcw; Interrupting Capacity, 500 amp	260 2695 00
C51	Same as C49		CR1	RECTIFIER, SILICON: Peak Inverse Voltage, 400; Max Current Rating, 1.5 at 100°C ambient	353 1560 00
C52	Same as C23		CR12		
C53	Same as C23		CR13	RECTIFIER, GERMANIUM: 1N198 diode	353 0160 00
			CR14	RECTIFIER, GERMANIUM: Matched pair of 1N198 diodes	353 0185 00
			CR15	NOT USED	
			CR16	RECTIFIER, GERMANIUM: RMS input Voltage 140; DC Output Voltage, 63 ±3 Volts; DC Output Current, 500 ma	353 1021 00
			CR17	RECTIFIER, SILICON: Peak Inverse Voltage, 400; Max Current Rating, 0.5 amp	353 1567 00
			CR18	Same as CR17	
			CR19	Same as CR17	
			CR20	Same as CR17	
			CR40	Same as CR13	
			DS1	LIGHT BULB: Candelabra Base; Current 0.027; 125 vdcw; 3 w	262 3310 00
			DS2	Same as DS1	
			E1	LENS HOLDER: Color, RED; for use with DS1	262 0259 00

SECTION VI  
Parts List

Linear Power Amplifier 204F-1

ITEM	DESCRIPTION	COLLINS PART NUMBER
E2	LENS HOLDER: Color GREEN; For use with DS2	262 0258 00
E35	ARRESTOR: Carbon Block	541 6779 002
F1	FUSE, CARTRIDGE: Resistance, 0.5 ohm; Current Rating, .1.00 amp; 250 vdcw, max	264 4280 00
F2	FUSE, CARTRIDGE: Resistance, 29 ohms; Current Rating, 0.125 amp; 250 vdcw, max	264 4230 00
F3	Same as F1	
F4	Same as F1	
F5	FUSE, CARTRIDGE: Resistance, 1.75 ohms; Current Rating, 0.500 amp; 250 vdcw, max	264 4260 00
F6	FUSE, CARTRIDGE: Dual Element Time Delay; Current Rating, 4 amp; Max Voltage Rating, 32	264 0110 00
J1	CONNECTOR, RECEPTACLE: UG-912/U, Type BNC; Single Contact	357 9307 00
J2	Same as J1	
J3	Same as J1	
J4	CONNECTOR, RECEPTACLE: Chassis Mounting Socket with Angle Brackets; Twelve Prongs	366 2120 00
J5	SOCKET, CRYSTAL: Two Terminal Crystal Socket for 0.125 diameter pins spaced 0.500 In.	292 0017 00
J6	CONNECTOR, RECEPTACLE: UG-352A/U Type LC receptacle	357 9187 00
J7	Same as J1	
J8	Same as J6	
K1	CONTACTOR, POWER: Contact arrangement, 4 pole, normally open; Contact rating, 10 amp; Coil Voltage, 115 Volts, +10 -15	401 1357 00
K2	RELAY, TIME DELAY: Contact arrangement, 1C (SPDT); Contact rating, 10 amp at 115 Volts AC; Coil Voltage, 115 Volts AC; Time delay, 3 minutes ±10	402 0337 00
K3	RELAY, GENERAL PURPOSE: Contact arrangement, 4C (4PDT); Contact rating, 10 amp at 115 Volts AC; Coil Voltage, 115 Volts AC. Coil Resistance, 330 ohms, ±10%	970 1933 00
K4	CONTACTOR, POWER: Contact arrangement, 4 pole, normally open; Contact rating, 25 amp; Coil Voltage, 115 Volts, -10 -15	401 1369 00
K5	RELAY, SENSITIVE: 1 amp 28 Volts DC or 115 Volts AC; Operate current, .70 ma Dc max	408 1073 00
K6	RELAY, SPECIAL PURPOSE: Contact arrangement, SPST; Contact rating, 25 amp at 28 VDC or 115 VAC; Coil Voltage, 48 Volts DC; Coil Resistance, 600 ohms, ±10%	970 1930 00
K7	RELAY, GENERAL PURPOSE: Contact arrangement, 2C (DPDT); Contact rating, 10 amp at 115 VAC; Coil Voltage, 28 Volts DC or 115 Volts AC; Coil Resistance, 390 ohms, ±10%	970 1934 00
K8	RELAY, GENERAL PURPOSE:	408 1080 00
K9	CONTACT, CIRCUIT CONTROL: Contact arrangement, 4C; Contact rating, 0.2 amp at 300 VDC and 2 amp RF; Coil Voltage, 115 Volts AC; Coil Resistance, 220 ohms, ±10%	970 1932 00
K10	Same as K9	
K11	RELAY, SOLENOID: Pull Type Solenoid; Voltage, 115 VAC, 50/60 cps; Current, 2.5 amp surge	411 0018 00
K12	Same as K7	
K13	NOT USED	
K14	RELAY, CIRCUIT CONTROL: Contact arrangement, 2C; Contact rating, 2 amp at 300 VDC, Coil Voltage, 115 Volts AC; Coil Resistance, 400 ohms, ±10%	970 1931 00
L1	COIL ASSEMBLY:	544 5984 003
L2	Same as L1	
L3	CHOKER, RADIO FREQUENCY: Inductance, 400uh; DC Resistance, 2.1 ohms max; Current rating, 700 ma	240 0023 00
L4	CHOKER, RADIO FREQUENCY: Inductance, 5.6 ±10%; DC Resistance, 0.95 ohms; max DC current, 1300 ma	240 0179 00
L5	CHOKER, RADIO FREQUENCY: Inductance, 22 uh ±10%; DC Resistance, 0.3 ohms; max DC Current, 1800 ma	240 0186 00
L6	Same as L1	
L7	Same as L1	
L8	Same as L3	
L9	Same as L3	
L10	Same as L3	
L11	Same as L3	
L12	COIL ASSEMBLY:	544 5988 003
L13	CHOKER, RADIO FREQUENCY: Inductance, 1.0 mh ±10%; "Q" 70 min at 790 KC; Current Capacity, 60 ma	240 0313 00

ITEM	DESCRIPTION	COLLINS PART NUMBER
L14	INDUCTOR, RADIO FREQUENCY: RF fixed tank inductor; 3 external spacer bar type Construction; approx inductance, 20 uh	980 0120 00
L15	Same as L14	
L16	CHOKER, RADIO FREQUENCY: Inductance, approx 44 uh; DC Resistance, 3.54 ohms; Current Capacity, 1.6 amp max DC	240 0807 00
L17	COIL, RADIO FREQUENCY: single layer wound; two #18 AWG x 1-1/2 in. lg terminals; 44 uh inductance; 1.6 amp dc current	240 0807 00
L18	Same as L5	
L19	Same as L5	
L20	Same as L5	
L21	REACTOR, FILTER: Inductance, 0.25; Rated Current, 1.6 amp d-c; DC Resistance, 5 ohms max at +25°C	668 0343 00
L22	REACTOR, FILTER: Inductance, 4.0; Rated Current, 1.6 amp d-c; DC Resistance, 25 ohms max at +25°C	668 0341 00
L23	REACTOR, FILTER: Inductance, 2.0; Rated Current, 1.8 amp d-c; DC Resistance, 11 ohms max at +25°C	668 0342 00
L24	REACTOR, FILTER: Inductance, 8.0; Rated Current, 55 ma DC; DC Resistance, 225 ohms max at 25°C	678 9001 00
L25	CHOKER, RADIO FREQUENCY: Inductance, 200 uh ±5%; Current Capacity, 100 ma	240 0198 00
L26	Same as L25	
L27	Same as L3	
L28	Same as L3	
L29	COIL, PA, FIXED TURN: Left-hand wound; 1 turn soft copper tubing, bright alloy plated, 3/8 in. dia by .032 in. thk wall	544 5992 003
L30	COIL, PA, FIXED TURN: Right-hand wound; 1 turn soft copper tubing, bright alloy plated, 3/8 in. dia by .032 in. thk wall	544 5991 003
L31	CHOKER, RADIO FREQUENCY: Inductance, 4.7 uh ±10% or 3.9 uh ±10% as selected by production test	240 0145 00 240 0144 00
M1	METER, DC AMMETER: D'Arsonval movement; Range, 0-2 amp; Scale div 40; Meter Resistance, 0.025 ohms; Accuracy, ±2%	450 0099 00
M2	METER, DC: Meter Range, 0-200 V ADC, Adjust to 40-0-160 U.A; Meter Resistance, 1000 ohms, ±5%; Accuracy, ±2% of full scale deflection	458 0474 00
M3	NOT USED	
M4	METER, ELAPSED TIME: Meter Range, 0-10,000 hours in 0.1 hour steps	458 0900 00
R1	RESISTOR, FIXED, COMPOSITION: 220 ohms, ±10%; 1/2 w	745 1324 00
R2	RESISTOR, FIXED, COMPOSITION: 82 ohms, ±10%; 1/2 w	745 1307 00
R3	RESISTOR, FIXED, COMPOSITION: 39,000 ohms, ±10%; 1/2 w	745 1419 00
R4	RESISTOR, FIXED, COMPOSITION: 2500 ohms, ±10%; 1/4 w	747 0772 00
R5	RESISTOR, FIXED, COMPOSITION: 1 megohm, ±10%; 1/2 w	745 1478 00
R6	RESISTOR, FIXED, COMPOSITION: 5600 ohms, ±10%; 1/2 w	745 1384 00
R7	RESISTOR, FIXED, COMPOSITION: 1000 ohms, ±10%; 2 w	745 5652 00
R8	RESISTOR, FIXED, FILM: 1100 ohms, ±1%; 1/4 w	705 7098 00
R9	RESISTOR, FIXED, COMPOSITION: 270 ohms, ±10%; 2 w	745 5628 00
R10	Same as R9	
R11	Same as R4	
R12	Same as R4	
R13	NOT USED	
R14	NOT USED	
R15	RESISTOR, VARIABLE, WIRE WOUND: 7500 ohms, ±10%; 2 w	750 0544 00
R16	RESISTOR, FIXED, COMPOSITION: 33 ohms, ±10%; 1/2 w	745 1289 00
R17	Same as R7	
R18	RESISTOR, FIXED, WIRE WOUND: 0.4 ohm, ±1%; 3 w	747 9623 00
R19	Same as R7	
R20	RESISTOR, FIXED, COMPOSITION: 15 ohms, ±10%; 1 w	745 3275 00
R21	RESISTOR, FIXED, WIRE WOUND: 4.1 ohms, ±10%, Rated amp, 7.6	714 1613 00
R22	RESISTOR, VARIABLE, WIRE WOUND: 1000 ohms, ±10%, Rated amp, 0.16	735 0050 00
R23	RESISTOR, VARIABLE, WIRE WOUND: 25 ohms, ±10%, Rated amp, 1.0	735 0039 00

3266

## Linear Power Amplifier 204F-1

ITEM	DESCRIPTION	COLLINS PART NUMBER	ITEM	DESCRIPTION	COLLINS PART NUMBER
R24	RESISTOR, FIXED, WIRE WOUND: 20,000 ohms, $\pm 5\%$ ; 210w	746 6723 00	S4	Same as S1	
R25	Same as R24		S5	SWITCH, CARTRIDGE: Thermo Switch; Opening Temperature 257°F $\pm 10^\circ$ F, Non-adjusting; Electrical Rating, 1 amp at 115 VAC and 32 VDC	267 0088 00
R26	RESISTOR, FIXED, WIRE WOUND: 2000 ohms, $\pm 5\%$ ; 113 w	747 3706 00	S6	SWITCH, MICRO: Snap Action Single Pole Double Throw Micro Switch; Rating, 5 amp; 250 Volts AC	260 0700 00
R27	RESISTOR, FIXED, WIRE WOUND: 0.4 ohms, $\pm 3\%$ ; 25 w	747 9535 00	S7	SWITCH, TOGGLE: SPDT; Current Capacity, 4.0 amp	266 3075 00
R28	RESISTOR, FIXED, COMPOSITION: 2700 ohms, $\pm 10\%$ ; 2 w	745 5670 00	S8	SWITCH, THERMOSTATIC: Opening Temperature $\pm 10^\circ$ C $\pm 3^\circ$ ; Closing Temperature, $+20 \pm 3^\circ$ C; Operating Volt DC, 6, 12, 30, 50; AC, 125, 250	266 0072 00
R29	Same as R7		S9	SWITCH, ROTARY, WAFER: 2 Circuit (2 pole), 3 Position, 1 section with 30° Detent and stops	259 1002 00
R30	RESISTOR, FIXED, FILM: 4.9 megohms, $\pm 1\%$ ; 2 w	705 4255 00	S10	SWITCH, ROTARY, WAFER: 2 Circuit (2 pole), 8 Position, 1 section with 20° Detent and stops	259 1001 00
R31	Same as R30		S11	SWITCH ASSEMBLY, SHORTING:	543 1460 003
R32	Same as R30		S12	Same as S11	
R33	Same as R30		T1	TRANSFORMER, STEP-DOWN: Primary Leads 1 and 2, 200 Volts; 1 and 3, 210 Volts; 1 and 4, 220 Volts; 1 and 5, 230 Volts; 1 and 6, 240 Volts; 1 and 7, 250 Volts; Secondary Leads 8 and 9, 115 Volts $\pm 2$	662 0338 00
R34	Same as R30		T2	TRANSFORMER, FILAMENT: Primary Voltage, 115; Secondary Voltage, 5, CT	672 0406 00
R35	RESISTOR, FIXED, COMPOSITION: 470,000 ohms, $\pm 10\%$ ; 1 w	745 3464 00	T3	TRANSFORMER, POWER: Primary Leads 1 and 2, Primary Voltage, 230; Secondary Leads 3 and 4, Necessary as to Application	662 0336 00
R36	RESISTOR, FIXED, WIRE WOUND: 0.2 ohms, $\pm 1\%$ ; 5 w	747 9707 00	T4	TRANSFORMER, FILAMENT: Primary Leads 1 and 2, Primary Voltage, 220; Secondary Leads 3 and 4, 9 and 10, 6.3 $\pm 3\%$ Volts; Secondary Leads 5 and 6, 7 and 8, 6.0 $\pm 3\%$ Volts	662 0337 00
R37	Same as R36		T5	TRANSFORMER, POWER: Primary Leads 1 and 2, Primary Voltage, 230; Secondary Leads 3 and 4, Necessary Voltage as needed for Application	662 0339 00
R38	RESISTOR, FIXED, WIRE WOUND: 630 ohms, $\pm 5\%$ ; 11 w	747 0247 00	T6	TRANSFORMER, POWER: Primary Leads 1 and 2, Primary Voltage, 200; 1 and 3, 210; 1 and 4, 220; 1 and 5, 230; 1 and 6, 240; 1 and 7, 250; Secondary Leads 8 and 10, Necessary as to Application	662 0340 00
R39	RESISTOR, FIXED, COMPOSITION: 4700 ohms, $\pm 10\%$ ; 1/2 w	745 1380 00	TB1	TERMINAL BOARD: Barrier Type Terminal Board with 4 Screw Terminals	306 0778 00
R40	Same as R4		TB2	TERMINAL, STANDOFF: Center Conductor; Voltage Rating, 1000 VDC; Capacity, 5 uuf to Base	367 0442 00
R41	Same as R15		TB3	TERMINAL STRIP: Telephone Type terminal strip with 8 row of 20 terminals each	367 0432 00
R42	RESISTOR, VARIABLE, COMPOSITION: 10,000 ohms, $\pm 20\%$ ; 1/2 w	380 6277 00	TB4	TERMINAL STRIP: Single Screw Barrier Terminal Strip; 6 Terminals	367 0565 00
R43	RESISTOR, FIXED, COMPOSITION: 1000 ohms, $\pm 10\%$ ; 1/2 w	745 1352 00	TB5	TERMINAL BOARD: Hollow Lug Terminal Board with Double Ground Lug and Two Mounting Posts	306 0294 00
R44	RESISTOR, FIXED, COMPOSITION: 470 ohms, $\pm 10\%$ ; 1/2 w	745 1338 00	TB6	TERMINAL BOARD: For Mounting Resistors R30 Thru R35	544 5954 002
R45	RESISTOR, VARIABLE, COMPOSITION: 100 ohms, $\pm 20\%$ ; 1 w	380 5269 00	TB7	TERMINAL STRIP: Mounting Strip with 4 Solder Lug Terminals; One Terminal as a Ground	306 9032 00
R46	RESISTOR, FIXED, WIRE WOUND: 2.2 ohms, $\pm 3\%$ ; 25 w	747 9536 00	TB8	TERMINAL STRIP: 3 Solder Lug Terminal Strip with one Lug as a Ground	306 0001 00
R47	RESISTOR, FIXED, WIRE WOUND: 5 ohms, $\pm 10\%$ ; 14 w	747 0718 00	TB9	TERMINAL, TURRET: Cold Headed Turret Type Terminal for Staking into Terminal or Printed Board	306 0550 00
R48	RESISTOR, FIXED, WIRE WOUND: 25 ohms, $\pm 5\%$ ; 26 w	747 1654 00	TB10	TERMINAL BOARD, ASSEMBLY: Board contains 20 Terminals	544 5776 004
R49	RESISTOR, FIXED, WIRE WOUND: 41.6 ohms, $\pm 1\%$ ; 3 w	747 9689 00	TB11	TERMINAL BOARD, ASSEMBLY:	544 5948 002
R50	NOT USED		TB12	TERMINAL BOARD, ASSEMBLY:	544 5949 002
R51	RESISTOR, FIXED, COMPOSITION: 8200 ohms, $\pm 10\%$ ; 2 w	745 5691 00	TB13	Same as TB3	
R52	NOT USED		TB14	TERMINAL STRIP: Barrier Type; No. of Terminals, 10	367 0438 00
R53	NOT USED		TB15	TERMINAL STRIP: Two Solder Lug Terminal Strips with Separate Ground Lug	306 0168 00
R54	RESISTOR, FIXED, COMPOSITION: 47 ohms, $\pm 10\%$ ; 1/2 w	745 1296 00	V1	ELECTRON TUBE: Type 6CL6; 9 Pin Miniature	255 0216 00
R55	Same as R54		V2	ELECTRON TUBE: Type 6146; 7 Pin Miniature	256 0101 00
R56	RESISTOR, FIXED, COMPOSITION: 1200 ohms, $\pm 5\%$ ; 2 w	745 5655 00	V3	Same as V2	
R57	Same as R56		V4	ELECTRON TUBE: Type 4CX1000A	256 0123 00
R58	Same as R56		V5	Same as V4	
R59	Same as R56		V6	ELECTRON TUBE: Type 872A	256 0037 00
R60	Same as R56		V7	Same as V6	
R61	Same as R56				
R62	RESISTOR, FIXED, COMPOSITION: 2200 ohms, $\pm 10\%$ ; 2 w	745 5666 00			
R63	RESISTOR, VARIABLE, COMPOSITION: 10,000 ohms, $\pm 20\%$ ; 1/2 w	380 6290 00			
R64	RESISTOR, FIXED, COMPOSITION: 18,000 ohms, $\pm 10\%$ ; 2 w	745 5705 00			
R65	RESISTOR, FIXED, COMPOSITION: 5.6 ohms, $\pm 10\%$ ; 1/2 w	745 1546 00			
R66	Same as R65				
R67	NOT USED				
R68	NOT USED				
R69	RESISTOR, FIXED, COMPOSITION: 39,000 ohms, $\pm 10\%$ ; 1 w	745 3415 00			
R70	RESISTOR, FIXED, COMPOSITION: 10 ohms, $\pm 10\%$ ; 1 w	745 3268 00			
R71	Same as R70				
R72	Same as R70				
R73	Same as R70				
R74	NOT USED				
Thru					
R78					
R79	RESISTOR, VARIABLE, COMPOSITION: 100 ohms, $\pm 20\%$ ; 1 w	380 5269 00			
R80	RESISTOR, FIXED, COMPOSITION: 680 ohms, $\pm 10\%$ ; 2 w	745 5645 00			
S1	SWITCH, PUSHBUTTON: Pushbutton Station; Normally open and closed; Color, Red Button	260 2030 00			
S2	SWITCH, PUSHBUTTON: Pushbutton Station; Normally open and closed; Color, Red Button	260 2020 00			
S3	Same as S2				

SECTION VI  
Parts List

Linear Power Amplifier 204F-1

ITEM	DESCRIPTION	COLLINS PART NUMBER
V8	ELECTRON TUBE: Type 5726; 7 Pin Miniature	253 0003 00
XDS1	LAMPHOLDER: Panel mounting type lampholder	262 0255 00
XDS2	Same as XDS1	
XF1	FUSE HOLDER: Extractor post fuse holder for use with 3AG fuses; Rating, 15 amp; 125 Volts	265 1019 00
XF2	Same as XF1	
XV1	SOCKET, ELECTRON TUBE: 9 Pin Miniature	220 1337 00
XV2	SOCKET, ELECTRON TUBE: Eight Prong Octal Tube Socket	220 1005 00
XV3	Same as XV2	
XV4	SOCKET, ELECTRON TUBE: For use with V4	220 1333 00
XV5	Same as XV4	
XV6	SOCKET, TUBE: Bayonet Lock, Four Prong Base for Tubes with 50 Watt Base	220 5420 00
XV7	Same as XV6	
XV8	SOCKET, ELECTRON TUBE: 7 Pin Miniature	220 1203 00
Z1	SUPPRESSOR, ASSEMBLY: Resistance, 56 ohms; 1/2 w	545 6157 002
Z2	CONNECTOR PLATE:	544 5769 002
Z3	SUPPRESSOR: Resistance, 10 ohms	544 5778 002
Z4	Same as Z3	
Z5	SUPPRESSOR, PA GRID: Three turns of #18 AWG copper wire on 12 ohm $\pm 10\%$ , 1 w composition resistor	545 7768 002
Z6	Same as Z5	
The above parts list represents the basic symbolized items of the transmitter assembly in this publication, except as modified for each additional captioned item of equipment.		
LINEAR POWER AMPLIFIER 204F-1 Dual Input-Output with Directional Coupler (changes from 522 1130 00)		522 1130 011
C75	NOT USED	
DC1	DIRECTIONAL COUPLER: See separate parts list for component listing	544 5707 004
DC2	Same as DC1	
J9	Part of K13	
Thru		
J11		
K13	RELAY, COAXIAL: Contact arrangement, 1C; contact rating, 100 watts, at 160 mc; Coil Voltage, 28 Volts DC; Coil Resistance, 280 ohms, $\pm 10\%$	410 0129 00
K14	NOT USED	
K15	RELAY, ANTENNA INTERLOCK:	970 1934 00
LINEAR POWER AMPLIFIER 204F-1 Single Input-Output with Recycle Overload Unit (changes from 522 1130 00)		522 1130 012
	RECYCLE OVERLOAD UNIT: See separate parts list for component listing	544 9493 00
LINEAR POWER AMPLIFIER 204F-1 Dual Input-Output with Recycle Overload Unit (changes from 522 1130 00 are those listed under 522 1130 011 and 522 1130 012)		522 1130 013
LINEAR POWER AMPLIFIER 204F-1 Dual Input-Output with Wattmeter in Door (changes from 522 1130 00 are those listed under 522 1130 011, 522 1130 015, and the following)		522 1130 014
V6	ELECTRON TUBE: Type 4B32	256 0097 00
V7	Same as V6	
LINEAR POWER AMPLIFIER 204F-1 Single Input-Output with Wattmeter in Door (changes from 522 1130 00)		522 1130 015
DC1	DIRECTIONAL COUPLER: See separate parts list for component listing	544 5707 004

ITEM	DESCRIPTION	COLLINS PART NUMBER
M3	METER, DC MICROAMMETER: Meter Scale, 0-5KV; Meter Range, 0-100 UA DC; Meter Resistance, 2000 ohms $\pm 5\%$ ; Accuracy, $\pm 2\%$ of full scale deflection	458 0475 00
R75	RESISTOR, FIXED, COMPOSITION: 2000 ohms, $\pm 5\%$ ; 1/4 w	745 0759 00
R76	Same as R75	
R77	Same as R75	
R78	Same as R75	
S15	SWITCH, ROTARY, WAFER: 5 Circuit (5 pole), 4 Position, 1 section with 20° Detent and stops	259 1202 00
DIRECTIONAL COUPLER		544 5707 004
C1	CAPACITOR, ASSEMBLY: c/o brass plate 0.064 in. thk, 9/16 in. od, 8-32 NC-2B id, brass stud externally thd 8-32 NC-2B, 3/4 in. lg	543 3492 002
C2	CAPACITOR, ASSEMBLY: same as C1	543 3492 002
C3	CAPACITOR, FIXED, MICA: 100 uuf, $\pm 20\%$ , 500 v dc	912 0669 00
C4	CAPACITOR, FIXED, MICA: same as C3	912 0669 00
C5	CAPACITOR, FIXED, ELECTROLYTIC: aluminum; 8 uf, $-15\%$ $+100\%$ , 120 cps, 6 v dc	183 1167 00
C6	CAPACITOR, FIXED, ELECTROLYTIC: same as C5	183 1167 00
C7	CAPACITOR, FIXED, CERAMIC: 39 uuf, $\pm 1\%$ , 500 v dc	916 4350 00
C8	CAPACITOR, FIXED, CERAMIC: same as C7	916 4350 00
C9	CAPACITOR, FIXED, CERAMIC: 1000 uuf, $+80\%$ $-20\%$ , 500 v dc	913 1292 00
C10	CAPACITOR, FIXED, CERAMIC: same as C9	913 1292 00
C11	CAPACITOR, FIXED, CERAMIC: 68 uuf, $\pm 1\%$ , 500 v dc	916 4786 00
C12	CAPACITOR, FIXED, CERAMIC: same as C11	916 4786 00
CR1	SEMICONDUCTOR DEVICE, DIODE: germanium; Sylvania type 1N60	353 2010 00
CR2	SEMICONDUCTOR DEVICE, DIODE: same as CR1	353 2010 00
J1	CONNECTOR, RECEPTACLE, ELECTRICAL: 1 rd female contact, 50 ohms, straight shape	357 9187 00
J2	CONNECTOR, RECEPTACLE, ELECTRICAL: same as J1	357 9187 00
L1	COIL, RADIO FREQUENCY: universal wound, 4 pi; 139 turns #36 AWG each section; 2.0 mh inductance, 50,000 ohms; 100 ma current	240 0134 00
L2	COIL, RADIO FREQUENCY: same as L1	240 0134 00
R1	RESISTOR, FIXED, COMPOSITION: 10 ohms, $\pm 1\%$ , 2 w	714 1075 00
R2	RESISTOR, FIXED, COMPOSITION: same as R1	714 1075 00
*R3	RESISTOR, FIXED, FILM: 18,700 ohms, $\pm 1\%$ , 1/4 w	705 7157 00
*R3	RESISTOR, FIXED, FILM: 19,600 ohms, $\pm 1\%$ , 1/4 w	705 7158 00
*R3	RESISTOR, FIXED, FILM: 20,500 ohms, $\pm 1\%$ , 1/4 w	705 7159 00
*R3	RESISTOR, FIXED, FILM: 21,500 ohms, $\pm 1\%$ , 1/4 w	705 7160 00
*R3	RESISTOR, FIXED, FILM: 18,200 ohms, $\pm 1\%$ , 1/4 w	705 7298 00
*R3	RESISTOR, FIXED, FILM: 19,100 ohms, $\pm 1\%$ , 1/4 w	705 7303 00
*R3	RESISTOR, FIXED, FILM: 20,000 ohms, $\pm 1\%$ , 1/4 w	705 7304 00
*R3	RESISTOR, FIXED, FILM: 21,000 ohms, $\pm 1\%$ , 1/4 w	705 7305 00
*R3	RESISTOR, FIXED, FILM: 22,100 ohms, $\pm 1\%$ , 1/4 w	705 7306 00
*R4	RESISTOR, FIXED, FILM: same as *R3	705 7157 00
*R4	RESISTOR, FIXED, FILM: same as *R3	705 7158 00
*R4	RESISTOR, FIXED, FILM: same as *R3	705 7159 00
*R4	RESISTOR, FIXED, FILM: same as *R3	705 7160 00
*R4	RESISTOR, FIXED, FILM: same as *R3	705 7298 00
*R4	RESISTOR, FIXED, FILM: same as *R3	705 7303 00
*R4	RESISTOR, FIXED, FILM: same as *R3	705 7304 00
*R4	RESISTOR, FIXED, FILM: same as *R3	705 7305 00
*R4	RESISTOR, FIXED, FILM: same as *R3	705 7306 00
R5	RESISTOR, FIXED, COMPOSITION: 1000 ohms, $\pm 10\%$ , 1/2 w	745 1352 00
R6	RESISTOR, FIXED, COMPOSITION: same as R5	745 1352 00
*R3, R4	value selected in final test.	



Linear Power Amplifier 204F-1

ITEM	DESCRIPTION	COLLINS PART NUMBER
	RECYCLE OVERLOAD UNIT	544 9493 00
B1	RELAY, TIMER:	402 0124 00
C1	CAPACITOR, FIXED, ELECTROLYTIC: 60 uf, -0 +100%; 50 vdcw	183 1351 00

ITEM	DESCRIPTION	COLLINS PART NUMBER
K1	RELAY: Coil Voltage, 26.5 V; Coil Resistance 380 ohms, ±10%; C Type Contacts	972 1168 00
K2	Same as K1	
R1	RESISTOR, FIXED, COMPOSITION: 5600 ohms, ±10%; 1 w	745 3384 00
TB1	TERMINAL STRIP: 6 Terminal; 3-1/16 in. long	367 0434 00

349-350

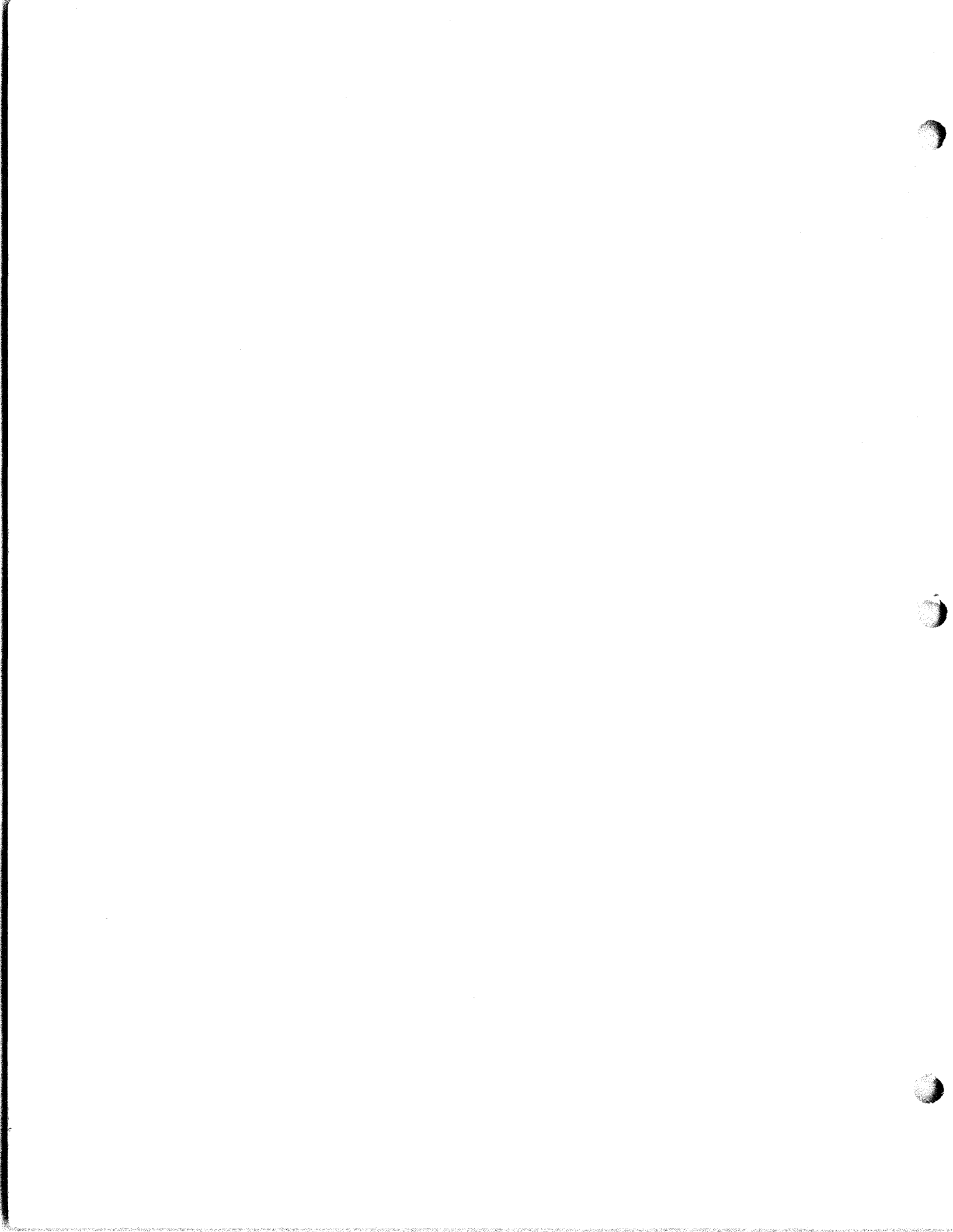

SECTION VII  
ILLUSTRATIONS

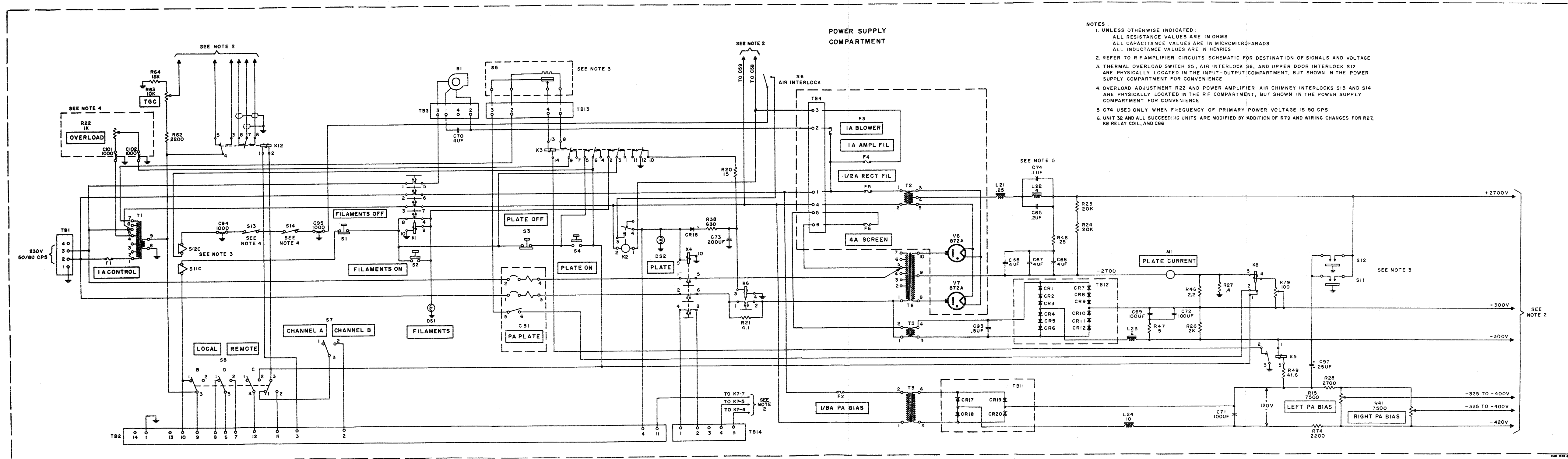

- NOTES:
1. UNLESS OTHERWISE INDICATED:  
ALL RESISTANCE VALUES ARE IN OHMS  
ALL CAPACITANCE VALUES ARE IN MICROMICROFARADS  
ALL INDUCTANCE VALUES ARE IN HENRIES
  2. REFER TO RF AMPLIFIER CIRCUITS SCHEMATIC FOR DESTINATION OF SIGNALS AND VOLTAGE
  3. THERMAL OVERLOAD SWITCH S5, AIR INTERLOCK S6, AND UPPER DOOR INTERLOCK S12 ARE PHYSICALLY LOCATED IN THE INPUT-OUTPUT COMPARTMENT, BUT SHOWN IN THE POWER SUPPLY COMPARTMENT FOR CONVENIENCE
  4. OVERLOAD ADJUSTMENT R22 AND POWER AMPLIFIER AIR CHIMNEY INTERLOCKS S13 AND S14 ARE PHYSICALLY LOCATED IN THE RF COMPARTMENT, BUT SHOWN IN THE POWER SUPPLY COMPARTMENT FOR CONVENIENCE
  5. C74 USED ONLY WHEN FREQUENCY OF PRIMARY POWER VOLTAGE IS 50 CPS
  6. UNIT 32 AND ALL SUCCEEDING UNITS ARE MODIFIED BY ADDITION OF R79 AND WIRING CHANGES FOR R27, K8 RELAY COIL, AND C66

Figure 7-1. Linear Power Amplifier 204F-1, Power Supply Circuits, Schematic Diagram

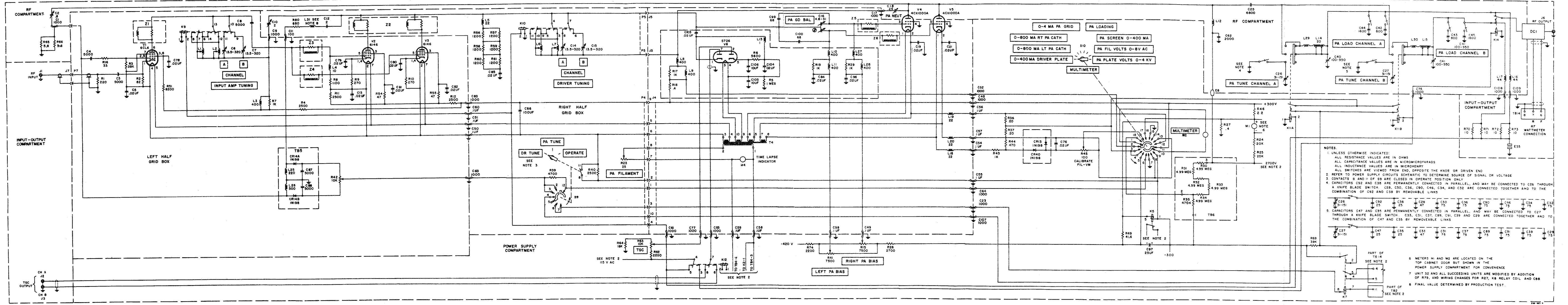

- NOTES:
- UNLESS OTHERWISE INDICATED:  
ALL RESISTANCE VALUES ARE IN OHMS  
ALL CAPACITANCE VALUES ARE IN MICROMICROFARADS  
ALL INDUCTANCE VALUES ARE IN MICRORHENRY  
ALL SWITCHES ARE VIEWED FROM END, OPPOSITE THE KNOB OR DRIVEN END
  - REFER TO POWER SUPPLY CIRCUITS SCHEMATIC TO DETERMINE SOURCE OF SIGNAL OR VOLTAGE
  - CONTACTS 8 AND 11 OF S9 ARE CLOSED IN OPERATE POSITION ONLY
  - CAPACITORS C92 AND C38 ARE PERMANENTLY CONNECTED IN PARALLEL, AND MAY BE CONNECTED TO C26 THROUGH A KNIFE BLADE SWITCH. C28, C30, C36, C90, C46, C34, AND C32 ARE CONNECTED TOGETHER AND TO THE COMBINATION OF C92 AND C38 BY REMOVABLE LINKS
  - CAPACITORS C47 AND C35 ARE PERMANENTLY CONNECTED IN PARALLEL, AND MAY BE CONNECTED TO C27 THROUGH A KNIFE BLADE SWITCH. C33, C31, C37, C89, C91, C39 AND C29 ARE CONNECTED TOGETHER AND TO THE COMBINATION OF C47 AND C35 BY REMOVABLE LINKS

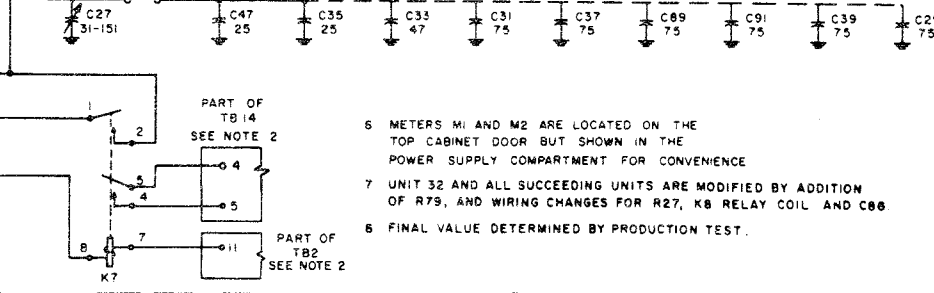

Figure 7-2. Linear Power Amplifier 204F-1, R-F Amplifier Circuits, Schematic Diagram

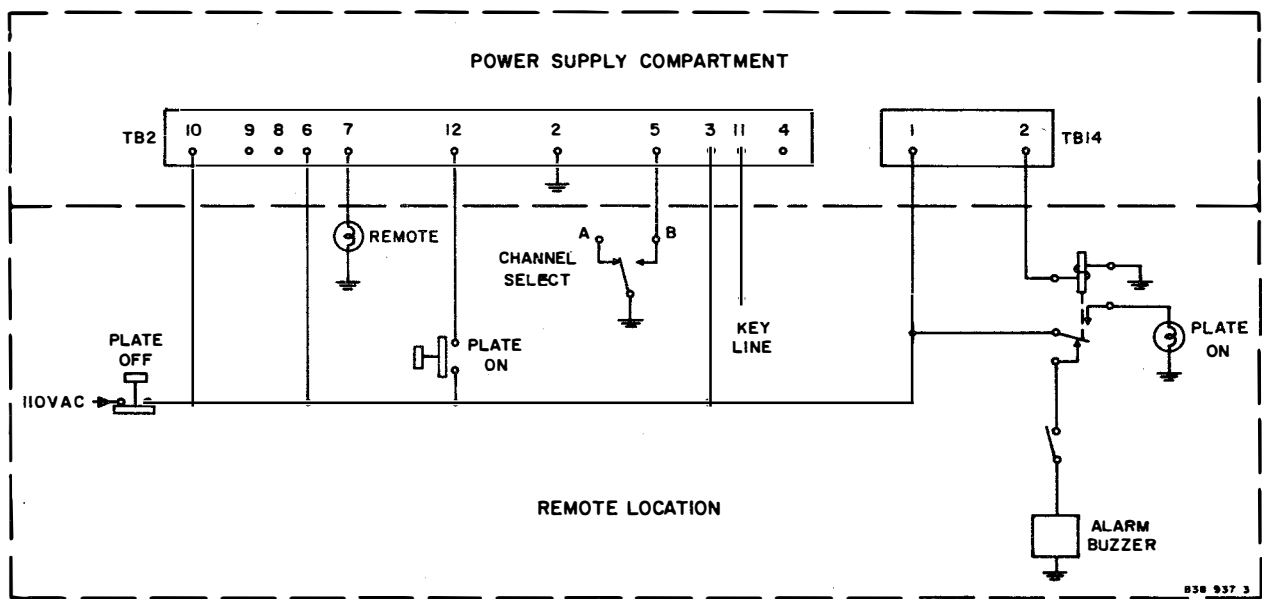
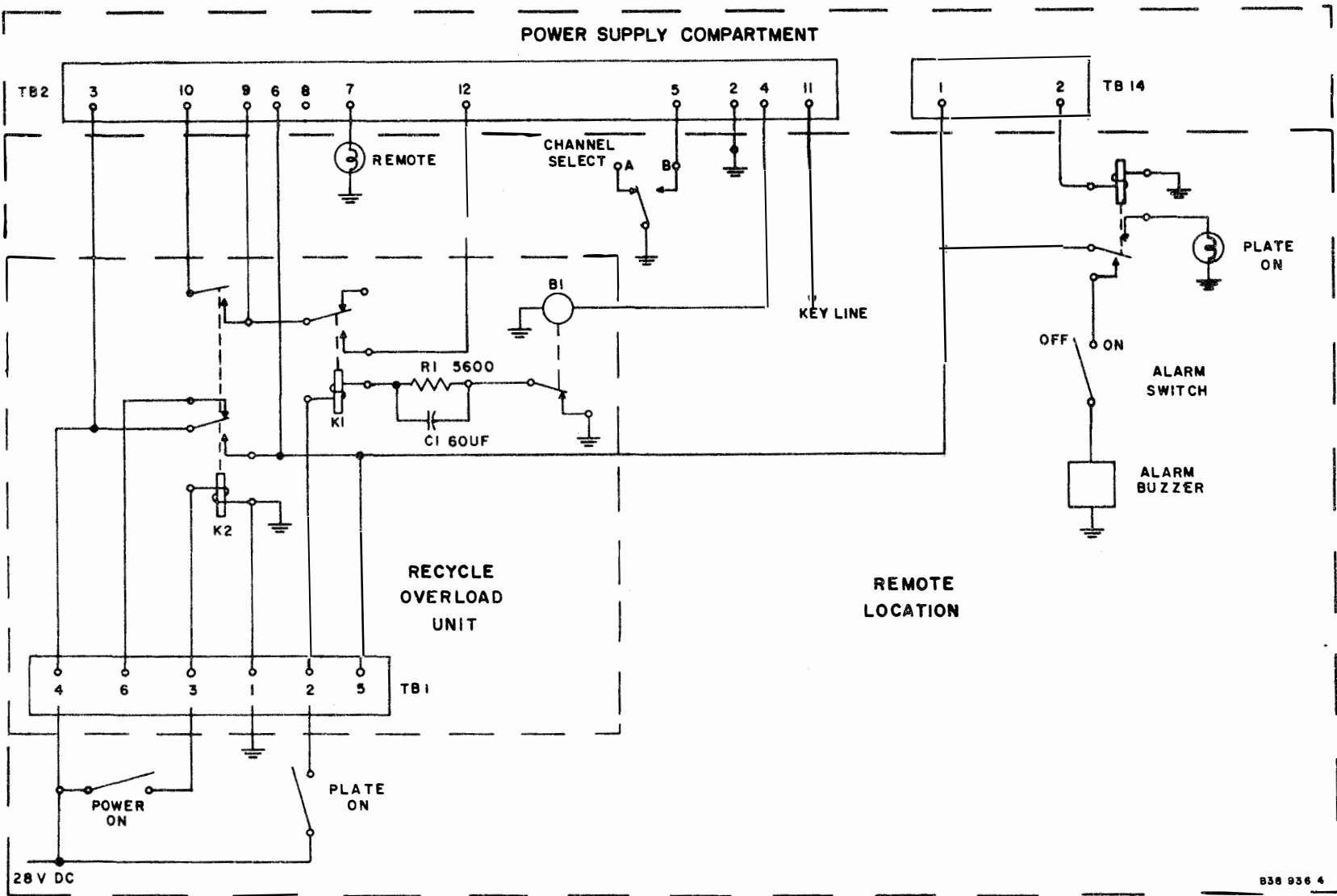

Figure 7-3. Linear Power Amplifier 204F-1, Typical Remote Control Circuit Connections



838 936 4

352

Figure 7-4. Typical Remote Control Circuit Connection,  
Recycle Overload Unit Installed

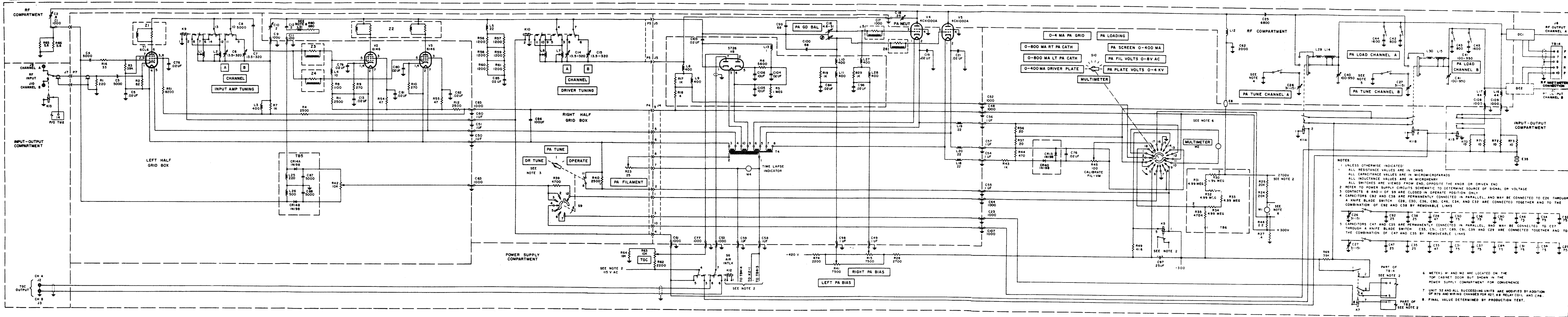

- NOTES:
- UNLESS OTHERWISE INDICATED: ALL RESISTANCE VALUES ARE IN OHMS ALL CAPACITANCE VALUES ARE IN MICROMICROFARADS ALL INDUCTANCE VALUES ARE IN MICRONEWRY
  - REFER TO POWER SUPPLY CIRCUITS SCHEMATIC TO DETERMINE SOURCE OF SIGNAL OR VOLTAGE
  - CONTACTS B AND H OF S9 ARE CLOSED IN OPERATE POSITION ONLY
  - CAPACITORS C92 AND C98 ARE PERMANENTLY CONNECTED IN PARALLEL, AND MAY BE CONNECTED TO C26 THROUGH A KNIFE BLADE SWITCH C35, C31, C37, C89, C91, C59 AND C29 ARE CONNECTED TOGETHER AND TO THE COMBINATION OF C92 AND C98 BY REMOVABLE LINKS
  - CAPACITORS C47 AND C55 ARE PERMANENTLY CONNECTED IN PARALLEL, AND MAY BE CONNECTED TO C27 THROUGH A KNIFE BLADE SWITCH C35, C31, C37, C89, C91, C59 AND C29 ARE CONNECTED TOGETHER AND TO THE COMBINATION OF C47 AND C55 BY REMOVABLE LINKS
  - METERS M1 AND M2 ARE LOCATED ON THE TOP CABINET DOOR BUT SHOWN IN THE POWER SUPPLY COMPARTMENT FOR CONVENIENCE
  - UNIT 32 AND ALL SUCCEEDING UNITS ARE MODIFIED BY ADDITION OF R79 AND WIRING CHANGES FOR R27, K8 RELAY COIL AND C46.
  - FINAL VALUE DETERMINED BY PRODUCTION TEST.

Figure 7-5. Linear Power Amplifier 204F-1, R-F Amplifier Circuits with Dual Input-Output Feature, Schematic Diagram

359-360

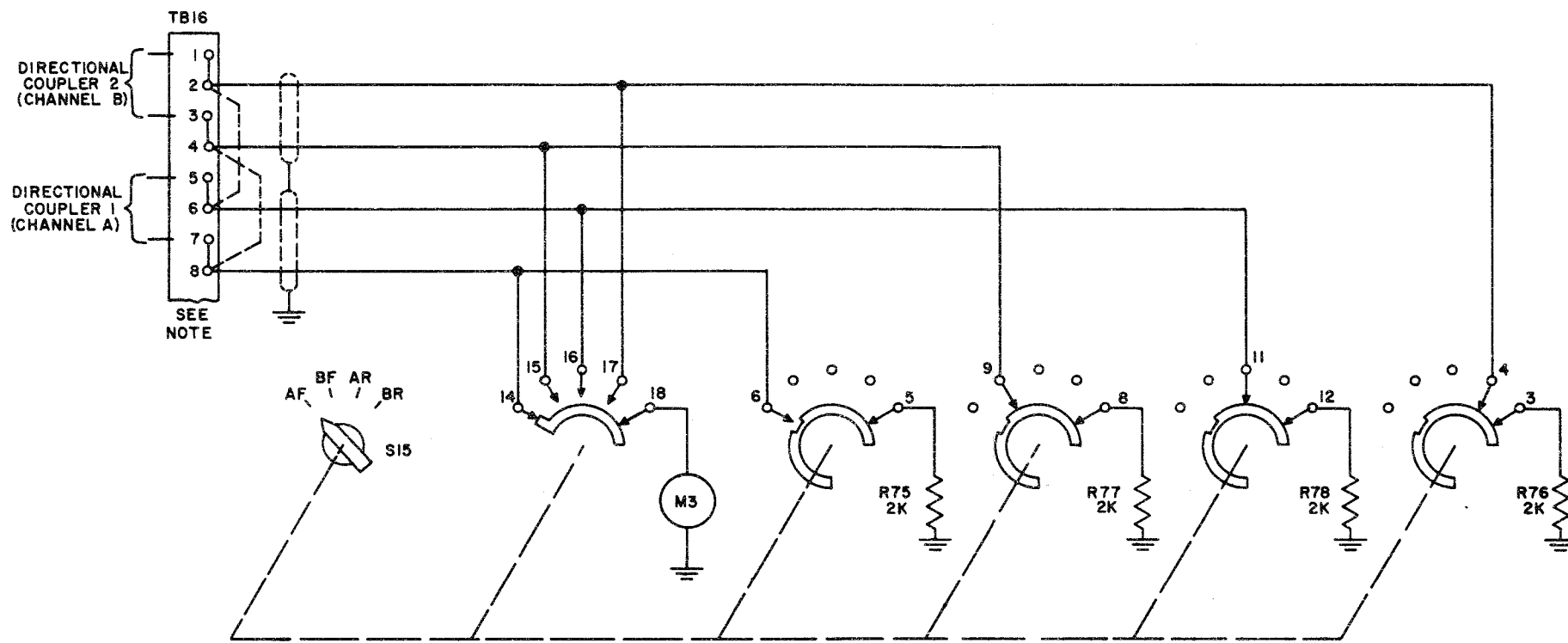

NOTE:

WHEN ONE DIRECTIONAL COUPLER IS USED, ADD JUMPERS 2-6 AND 4-8 AT TB16.  
WHEN EXTERNAL WATTMETER IS USED, REMOVE JUMPERS 1-2, 3-4, 5-6, AND 7-8 AT TB16.

Figure 7-6. Output Wattmeter Installed in the Door, Schematic Diagram



204F-1 CABLE CHART

FROM	TO	WIRE CODE	FROM	TO	WIRE CODE
C23	J4-3	RB905	C61	K12-5	RB936
C23	K7-8	RB905	C63	R42-2	RA95
C48	E3	RB912	C63	S9-2	RB925
C48	J4-9	RB912	C64	J4-1	RB925
C48	TB10-26	RB912	C64	S10-15	RB925
C48	S10-11	RB906	C65-1	L21-2	LE9
C49	R15-2	RB906	C65-2	R48-1	LE9
C49	TB10-13	RB906	C66-2	T6-9	VE91
C50	P4-6	RB96	C67-2	M1-2	VE91
C50	S9-11	RB96	C68-2	R24-1	VE91
C50	XV3-2	RB90	C69-2 (+)	TB12-4	RB912
C51	P4-5	RB91	C71-1 (+)	E42	RB923
C51	XV3-7	RB91	C71-1 (+)	TB11-4	RB923
C52	S10-2	RB915	C71-2 (-)	E41	RB916
C52	TB10-25	RB915	C71-2 (-)	L24-2	RB916
C53	K12-7	RAS9	C72-2 (+)	R26-1	RB912
C53	TB10-6	RAS9	C73 (-)	K6-4	RB9
C54	E16	RB902	C73 (+)	K6-3	RB902
C55	E4	RB913	C75	K12-3	RB926
C55	J4-2	RB913	C77	R63-2	RB916
C56	S10-12	RB935	C77	TB10-2	RB916
C57	S10-13	RB926	C83	P4-9	RB912
C58	K2-1	RB93	C93-1	T5-4	RB91
C58	TB4-3	RB93	C93-1	TB12-1	RB91
C58	M4-2	RB93	C93-2	T5-3	RB91
C58	T4-1	RB93	C93-2	TB12-2	RB91
C59	J4-7	RB92	C94-1	S12C-2	RB92
C59	M4-1	RB92	C95-1	S6-2	RB93
C59	T3-1	RB92	C98	R41-2	RB903
C60	K9-2	RA925	C98	TB10-15	RB903
C60	K10-2	RA936	C101	T1-4	RB902
C60	P4-4	RB936	C102	K3-9	RB903
C61	J4-4	RB936	C107	E35	RB95

204F-1 CABLE CHART (Cont)

FROM	TO	WIRE CODE	FROM	TO	WIRE CODE
C107	J4-10	RB95	E4	R26-2	RB913
C108	TB15-3	RB92	E4	S10-9	RB913
C109	TB15-1	RB92	E4	S11B	RB913
CB1-1	TB1-2	VG90	E4	TB6-1	RB913
CB1-2	TB1-3	VG91	E5	E1	RB9
CB1-3	K4-2	VG92	E5	K5-3	RB9
CB1-4	K4-1	VG93	E5	T1-8	RB9
CB1-5	TB13-3	RB903	E7	K8-5	RB91
CB1-6	K8-2	RB903	E7	M1-1	VE90
CR16-1	K4-9	RB902	E8	S11A	LE9
DC1 (fwd)	TB14-6	RAS92	E9	K10-1	RA9
DC1 (gnd)	TB14-8	S	E13	E42	RB93
DC1 (refl)	TB14-7	RAS91	E13	S10-5	RB93
DC2 (fwd)	TB14-10	RAS90	E14	S10-13	RB926
DC2 (gnd)	TB14-8	S	E16	C54	RB902
DC2 (refl)	TB14-9	RAS9	E17	TB2-1	RB9
DS1-1	E1	RB9	E18	TB4-8	RB902
DS1-2	S2-2	RB93	E19	T4-5	RB935
DS2-1	E1	RB9	E20	T4-7	RB926
DS2-2	K2-4	RB902	E35	C107	RB95
E1	DS1-1	RB9	E35	E40	RB9
E1	DS2-1	RB9	E38	K12-4	RB95
E1	E5	RB9	E39	GND (C49)	S
E2	K1-10	RB9	E39	GND (J2)	S
E2	K4-10	RB9	E40	E35	RB9
E2	TB1-1	VG9	E41	C71-2	RB916
E3	C48	RB912	E42	E13	RB93
E3	K8-4	RB91	E42	C71-1 (+)	RB923
E3	R26-1	RB912	E43	K3-10	RB923
E3	S10-16	RB912	F1-1	TB1-2	RC90
E4	C55	RB913	F1-2	T1-1	RC90
E4	K5-1	RB913	F2-1	K1-6	RB9356
E4	K7-1	RB913	F2-2	T3-2	RB90

362

204F-1 CABLE CHART (Cont)

FROM	TO	WIRE CODE	FROM	TO	WIRE CODE
GND (C49)	E39	S	K1-9	S2-2	RB93
GND (C53)	TB10-12	S	K1-10	E2	RB9
GND (J2)	E39	S	K2-1	C58	RB93
GND (J2)	GND (J7)	S	K2-2	K1-7	RB93
GND (J7)	GND (J2)	S	K2-3	S6-1	RB93
J1	J7	RG-58C/U	K2-4	DS2-2	RB902
J2	K12-8	RAS90	K2-4	K4-9	RB902
J3	K12-6	RAS92	K2-4	TB2-4	RB902
J4-1	C64	RB925	K3-2	K1-4	RB93
J4-2	C55	RB913	K3-3	K1-8	RB902
J4-3	C23	RB905	K3-5	S4-1	RB96
J4-4	C61	RB936	K3-6	S12C-1	RB95
J4-5	T4-4	RB91	K3-6	K8-1	RB912
J4-6	T4-3	RB96	K3-8	TB13-1	RB913
J4-7	C59	RB92	K3-9	C102	RB903
J4-8	T4-2	RB90	K3-10	E43	RB923
J4-9	C48	RB912	K3-12	K6-4	RB90
J4-10	C107	RB95	K3-13	TB13-4	RB92
J7	J1	RG-58C/U	K3-14	K5-2	RB9
K1-1	TB1-3	RB91	K4-1	CB1-4	VG93
K1-2	TB1-2	RC90	K4-2	CB1-3	VG92
K1-3	TB1-5	RC92	K4-4	TB14-1	RB926
K1-4	K1-9	RB93	K4-5	T6-5	VG93
K1-4	K3-2	RB93	K4-6	R21-1	VG92
K1-5	TB3-3	RB91	K4-8	TB14-2	RB925
K1-6	F2-1	RB9356	K4-9	CR16-1	RB902
K1-6	TB4-1	RC913	K4-9	K2-4	RB902
K1-7	K2-2	RB93	K4-10	E2	RB9
K1-7	T3-1	RB92	K4-10	K6-4	RB9
K1-7	TB4-4	RB92	K5-1	E4	RB913
K1-8	K3-3	RB902	K5-2	K3-14	RB9
K1-8	S2-1	RB902	K5-3	E5	RB9
K1-9	K1-4	RB93	K5-5	S10-14	RB905

204F-1 CABLE CHART (Cont)

FROM	TO	WIRE CODE	FROM	TO	WIRE CODE
K6-1	R21-1	VG92	K12-6	J3	RAS92
K6-2	R21-2	VG92	K12-7	C53	RAS9
K6-3	C73 (+)	RB902	K12-8	J2	RAS90
K6-4	C73 (-)	RB9	K13-2	TB2-14	RB90
K6-4	K3-12	RB90	L21-1	T2 (C. T.)	LE9
K6-4	K4-10	RB9	L21-2	C65-1	LE9
K7-1	E4	RB913	L21-2	L22-1	LE9
K7-2	K11-3	RB923	L22-1	L21-2	LE9
K7-4	TB14-5	RB906	L22-2	R48-1	LE9
K7-5	TB14-4	RB903	L23-1	TB12-3	RB913
K7-7	TB2-11	RB936	L23-2	R47-1	RB913
K7-8	C23	RB905	L24-1	TB11-3	RB916
K8-1	K3-6	RB912	L24-2	C71-2 (-)	RB916
K8-1	S4-2	RB902	M1-1	E7	VE90
K8-2	CB1-6	RB903	M1-2	C67-2	VE91
K8-4	E3	RB91	M2-1	S10-10	RB936
K8-5	E7	RB91	M2-2	S10-1	RB956
K9-1	TB7-2	RA9	M4-1	C59	RB92
K9-2	C60	RA925	M4-2	C58	RB93
K10-1	E9	RA9	P4-1	S9-12	RB925
K10-2	C60	RA936	P4-2	S9-8	RB913
K11A-2	K12-5	RB936	P4-3	S9-6	RB905
K11A-4	S10-3	RB923	P4-4	C60	RB936
K11B-2	K12-3	RB926	P4-5	C51	RB91
K11-3	K7-2	RB923	P4-6	C50	RB96
K12-1	TB2-3	RB95	P4-7	R23-1	RB92
K12-2	S8A-3	RB9	P4-8	R23-2	RB90
K12-3	C75	RB926	P4-9	C83	RB912
K12-3	K11B-2	RB926	P4-10	S9-4	RB95
K12-4	E38	RB95	P7	TB9-3	S
K12-4	S8B-3	RB93	P7	TB9-4	RG-58C/U
K12-5	C61	RB936	R4	TB9-5	RA96
K12-5	K11A-2	RB936	R12	TB7-3	RA926

## 204F-1 CABLE CHART (Cont)

FROM	TO	WIRE CODE	FROM	TO	WIRE CODE
R15-2	C49	RB906	S8A-2	TB2-5	RB95
R21-1	K4-6	VG92	S8A-3	K12-2	RB9
R21-1	K6-1	VG92	S8B-1	S11C-1	RB92
R21-2	K6-2	VG92	S8B-1	TB2-10	RB92
R21-2	T6-1	VG92	S8B-3	K12-4	RB93
R23-1	P4-7	RB92	S8B-3	T1-9	RB93
R23-2	P4-8	RB90	S8B-3	TB2-9	RB903
R24-1	C68-2	VE91	S8C-2	S4-2	RB902
R26-1	C72-2 (+)	RB912	S8C-3	TB2-12	RB906
R26-1	E3	RB912	S8D-1	TB2-8	RB913
R26-2	E4	RB913	S8D-2	TB2-7	RB916
R26-2	R47-1	RB913	S8D-3	TB2-6	RB915
R41-2	C98	RB903	S9-2	C63	RB925
R42-2	C63	RA95	S9-4	P4-10	RB95
R45-2	S10-17	RB902	S9-6	P4-3	RB905
R47-1	L23-2	RB913	S9-8	P4-2	RB913
R47-1	R26-2	RB913	S9-11	C50	RB96
R48-1	C65-2	LE9	S9-12	P4-1	RB925
R48-1	L22-2	LE9	S10-1	M2-2	RB956
R48-1	S11A	LE9	S10-2	C52	RB915
R63-2	C77	RB916	S10-3	K11A-4	RB923
S1-1	S11C-2	RB92	S10-5	E13	RB93
S2-1	K1-8	RB902	S10-9	E4	RB913
S2-1	S3-1	RB95	S10-10	M2-1	RB936
S2-2	DS1-2	RB93	S10-11	C48	RB906
S2-2	K1-9	RB93	S10-12	C56	RB935
S3-1	S2-1	RB95	S10-13	C57	RB926
S4-1	K3-5	RB96	S10-13	E14	RB926
S4-2	K8-1	RB902	S10-14	K5-5	RB905
S4-2	S8C-2	RB902	S10-15	C64	RB925
S6-1	K2-3	RB93	S10-16	E3	RB912
S6-2	C95-1	RB93	S10-17	R45-2	RB902
S7-2	TB2-2	RB93	S10-18	TB6-2	RB91

## 204F-1 CABLE CHART (Cont)

FROM	TO	WIRE CODE	FROM	TO	WIRE CODE
S11A	E8	LE9	T4-8	E18	RB902
S11A	R48-1	LE9	T4-8	XV5-1	RE96
S11A	S12A	LE9	T4-9	TB10-5	RB956
S11B	E4	RB913	T4-10	TB10-3	RB923
S11B	S12B	RB913	T5-1	T6-1	RC92
S11C-1	S8B-1	RB92	T5-2	TB4-5	RC95
S11C-2	S1-1	RB92	T5-3	C93-2	RB91
S12A	S11A	LE9	T5-4	C93-1	RB91
S12B	S11B	RB913	T6-1	R21-2	VG92
S12C-1	K3-6	RB95	T6-1	T5-1	RC92
S12C-2	C94-1	RB92	T6-5	K4-5	VG93
T1-1	F1-2	RC90	T6-5	TB4-6	RC95
T1-4	C101	RB902	T6-8	V7	LE9
T1-5	K1-3	RC92	T6-9	C66-2	VE91
T1-5	TB1-3	RC91	T6-10	V6	LE9
T1-7	TB13-2	RB905	TB1-1	E2	VG9
T1-8	E5	RB9	TB1-2	CB1-1	VG90
T1-9	S8B-3	RB93	TB1-2	F1-1	RC90
T2 (C. T.)	L21-1	LE9	TB1-2	K1-2	RC90
T3-1	C59	RB92	TB1-3	CB1-2	VG91
T3-1	K1-7	RB92	TB1-3	K1-1	RB91
T3-2	F2-2	RB90	TB1-3	T1-5	RC91
T3-3	TB11-2	RB915	TB2-1	E17	RB9
T3-4	TB11-1	RB915	TB2-2	S7-2	RB93
T4-1	C58	RB93	TB2-3	K12-1	RB96
T4-2	J4-8	RB90	TB2-4	K2-4	RB902
T4-3	J4-6	RB96	TB2-5	S8A-2	RB95
T4-4	J4-5	RB91	TB2-6	S8D-3	RB915
T4-5	E19	RB935	TB2-7	S8D-2	RB916
T4-5	XV4-2	RE90	TB2-8	S8D-1	RB913
T4-6	XV4-1	RE95	TB2-9	S8B-3	RB903
T4-7	E20	RB926	TB2-10	S8B-1	RB92
T4-7	XV5-2	RE91	TB2-11	K7-7	RB936

276

204F-1 CABLE CHART (Cont)

FROM	TO	WIRE CODE	FROM	TO	WIRE CODE
TB2-12	S8C-3	RB906	TB12-4	C69-2 (+)	RB912
TB2-14	K13-2	RB90	TB13-1	K3-8	RB913
TB3-2	TB4-2	RB91	TB13-2	T1-7	RB905
TB3-3	K1-5	RB91	TB13-3	CB1-5	RB903
TB4-1	K1-6	RC913	TB13-4	K3-13	RB92
TB4-2	TB3-2	RB91	TB14-1	K4-4	RB926
TB4-3	C58	RB93	TB14-2	K4-8	RB925
TB4-4	K1-7	RB92	TB14-4	K7-5	RB903
TB4-5	T5-2	RC95	TB14-5	K7-4	RB906
TB4-6	T6-5	RC95	TB14-6	DC-1 (refl)	RAS92
TB6-1	E4	RB913	TB14-7	DC-1 (fwd)	RAS91
TB6-2	S10-18	RB91	TB14-8	DC-1 (gnd)	S
TB7-2	K9-1	RA9	TB14-8	DC-2 (gnd)	S
TB7-3	R12	RA926	TB14-9	DC-2 (refl)	RAS9
TB9-3	P7	S	TB14-10	DC-2 (fwd)	RAS90
TB9-4	P7	RG-58C/U	TB15-1	C109	RB92
TB9-5	R4	RA96	TB15-3	C108	RB92
TB10-2	C77	RB916	V6	T6-10	LE9
TB10-3	T4-10	RB923	V7	T6-8	LE9
TB10-5	T4-9	RB956	XV1-4	XV2-2	RA90
TB10-6	C53	RAS9	XV1-5	XV2-7	RA91
TB10-12	GND (C53)	S	XV2-2	XV1-4	RA90
TB10-13	C49	RB906	XV2-2	XV3-2	RA90
TB10-15	C98	RB903	XV2-7	XV1-5	RA91
TB10-25	C52	RB915	XV2-7	XV3-7	RA91
TB10-26	C48	RB912	XV3-2	C50	RB90
TB11-1	T3-4	RB915	XV3-2	XV2-2	RA90
TB11-2	T3-3	RB915	XV3-7	C51	RB91
TB11-3	L24-1	RB916	XV3-7	XV2-7	RA91
TB11-4	C71-1 (+)	RB923	XV4-1	T4-6	RE95
TB12-1	C93-1	RB91	XV4-2	T4-5	RE90
TB12-2	C93-2	RB91	XV5-1	T4-8	RE96
TB12-3	L23-1	RB913	XV5-2	T4-7	RE91

367-368

