

RESTRICTED

Serial No. 258

**PRELIMINARY
INSTRUCTION BOOK
FOR
NAVY MODEL RBW-2
PANORAMIC RADIO ADAPTOR**

FREQUENCY
5.25 Megacycles

MAXIMUM SWEEPWIDTH
1 Megacycle

115/230 Volts, Single Phase
50/70 Cycles

**Manufactured for
U. S. Navy Department - Bureau of Ships
by
PANORAMIC RADIO CORPORATION
NEW YORK, N. Y.**

CONTRACT No. NX_{ss}-33781

DATED: June 30, 1943

Page	Line	Correction
		D. Two high voltage controls mounted on sub-chassis mycalex strip.
		1. Loosen the set screws in the insulating bushing.
		2. Loosen the hexagonal nut on the potentiometer.
		3. Unsolder the connections.
		4. Pull the potentiometer free of the mycalex strip."
40		Paragraph on Operation Failures should be numbered 11.07.
40		Insert the following at the end of the paragraph on Operation Failures: "Failure: Curved overload line on C.R.T. Look for: Gassy tube V104--6SQ7 (GT/G)."
41		Add the following statement at the top of the page: "These values correspond to a 115 Volt A.C. line voltage."
41		V109, Pin 3 should refer to Note (f).
41		V109, Pin 5 should refer to Note (g).
41		V110; "6X5GT" should read "6X5 (GT/G)".
45		E123: "Contact plate of V107" should read "Contact plate of V105".
52		T104: Description should read as follows: "Transformer, power, primary 115-230V., 50-70 cycles, 5 secondary windings, 590V. CT. at 55 MA., 525V. at 1.5 MA., 2.5V. at 1.75A., 6.4V. at 3A., 6.4V. at 0.6A."
52		V104: "6SQ7" should read "6SQ7 (GT/G)".
52		V110: "6X5GT" should read "6X5 (GT/G)".
58		SYMBOL DESIGNATION: The line beneath R110 should read "R119".
59		V104: "Tube 6SQ7" should read "Tube, 6SQ7 (GT/G)".
59		V110: "Tube, 6X5GT" should read "Tube, 6X5 (GT/G)".
60		Resistor Tolerance Code: Gold color indicates 5% tolerance. Silver color indicates 10% tolerance. Other resistors 20% tolerance.

ERRATA AND ADDENDA

INSTRUCTION BOOK---NAVY MODEL RBW-2 PANORAMIC ADAPTOR

Page	Line	Correction
12		Par. 1.04: Column heading "Navy or Commercial Type" should read "Type Designation".
12	27, 30	V108, V111: "6SL7(GT/G)" should read "6SL7-GT".
17	36	"center <u>FREQUENCY</u> " should read " <u>CENTER FREQ</u> (uency)".
19	1	Insert the paragraph number "3.05" in the left margin opposite this line.
23		Par. 5: Maximum Sweepwidth "1000 KC." should read "1000 KC. \pm 60 KC".
25	14	"#CPH-49193" should read "#CPH-49195".
31	13	"The calibration, etc." should read "The calibration at 1000 KC. is accurate to \pm 60 KC".
36	26	"on the screen at -500 KC." should read "on the screen at the center".
39	27	"R147" should read "R147(SYNCH.)".
39	31	"A.C. line voltage" should read "A.C. line frequency".
39	32	"5000 mmf." should read ".01 mfd."
40		<p>Paragraph 11.06 shall be inserted to read as follows:</p> <p>"11.06 <u>Removal of Semi-Adjustable Potentiometers</u></p> <p>Whenever it may become necessary to replace any of the seven semi-adjustable potentiometers, the process can be expedited by adherence to the following suggestions:</p> <p>"A. Remove the chassis from its cabinet (Par. 11.02-1). B. Remove the bottom plate from the chassis. C. Five low voltage controls mounted on a metal bracket above the chassis.</p> <ol style="list-style-type: none"> 1. Remove the two bolts and nuts which secure the bracket to the top of the chassis. <u>N.B.</u> Do not remove the two screws in the cut-out areas. They are for the high voltage potentiometer assembly. 2. Remove the flat-head screw from the front panel above SWEEP LIM. 3. Move the bracket out to the left of the chassis, where an end wrench and soldering iron may be used to remove the delinquent potentiometer.

"OPERATION OF THIS EQUIPMENT INVOLVES THE USE OF HIGH VOLTAGES WHICH ARE DANGEROUS TO LIFE. OPERATING PERSONNEL MUST AT ALL TIMES OBSERVE ALL SAFETY REGULATIONS. DO NOT CHANGE TUBES OR MAKE ADJUSTMENTS INSIDE EQUIPMENT WITH HIGH VOLTAGE SUPPLY ON. DO NOT DEPEND UPON DOOR SWITCHES OR INTERLOCKS FOR PROTECTION BUT ALWAYS SHUT DOWN MOTOR GENERATORS OR OTHER POWER EQUIPMENT. UNDER CERTAIN CONDITIONS DANGEROUS POTENTIALS MAY EXIST IN CIRCUITS WITH POWER CONTROLS IN THE OFF POSITION DUE TO CHARGES RETAINED BY CAPACITORS, ETC. TO AVOID CASUALTIES ALWAYS REMOVE POWER, DISCHARGE AND GROUND CIRCUITS PRIOR TO TOUCHING THEM."

ELECTRIC SHOCK FIRST AID TREATMENT

SAFETY FIRST. Regard electrical apparatus generally, and especially all current-carrying parts, as dangerous, irrespective of voltage. Exercise great care in handling, and avoid broad contacts such as are made by standing on a metal deck or in water.

Dangerous contact may result through lessened resistance when the skin and clothing are wet with perspiration. Contact with damp metal surfaces -- decks, bulkheads, guns, machinery -- may allow the current to ground through the moist skin and body.

Electric shock is due to current passing through the body -- current actually passing -- irrespective of the voltage. A pressure as low as 110 volts has caused death. Current passing through the body in the region of the heart is especially dangerous. In using electric breast drills avoid the possibility of a ground.

Usually electric shock does not kill instantly. Life can often be saved even though breathing has stopped.

- I. **FREE THE VICTIM FROM THE CIRCUIT IMMEDIATELY.** Use a dry non-conductor (rubber gloves, clothing, rope, board) to move either the victim or the wire. Beware of using metal or moist material. Shut off the current. If necessary to cut a live wire, use an ax or hatchet with a dry wooden handle; turn your face away from the electrical flash.
- II. **ATTEND INSTANTLY TO THE VICTIM'S BREATHING.** Begin resuscitation at once on the spot. Do not stop to loosen clothing; every moment counts.

RESUSCITATION BY THE PRONE PRESSURE METHOD OF ARTIFICIAL RESPIRATION

Waste no time. When the patient is removed from the water, gas, smoke, or electric contact, get to work at once with your own hands. Send for the medical officer or nearest physician.

No reliance should be placed upon any special mechanical apparatus, as it is frequently out of order and often is not available when most needed. The patient's

mouth should be cleared of any obstruction such as chewing gum or tobacco, false teeth, or mucus, so that there is no interference with the entrance and escape of air.

POSITION

- 1.- Lay the patient on his belly, one arm extended directly overhead, the other arm bent at elbow and with the face turned outward and resting on hand or forearm, so that the nose and mouth are free for breathing.
- 2.- Kneel straddling the patient's thighs with your knees placed at such a distance from the hip bones as will allow you to place the palms of the hands on the small of the back with fingers resting on the ribs, the little finger just touching the lowest rib, with the thumb and fingers in a natural position, and the tips of the fingers just out of sight.

FIRST MOVEMENT

- 3.- With arms held straight, swing forward slowly, so that the weight of your body is gradually brought to bear upon the patient. The shoulder should be directly over the heel of the hand at the end of the forward swing. Do not bend your elbows. The operation should take about two seconds.

SECOND MOVEMENT

- 4.- Now immediately swing backward, so as to remove the pressure completely.
- 5.- After two seconds, swing forward again. Thus repeat deliberately twelve to fifteen times a minute the double movement of compression and release, a complete respiration in four or five seconds.
- 6.- Continue artificial respiration without interruption until natural breathing is restored. Do not get discouraged at the slow results that sometimes happen. Efforts often have to be continued a long time before signs of life are apparent. Do not discontinue the efforts until certain that all chance is lost. Sometimes, even after several hours' work, recovery takes place.
- 7.- As soon as this artificial respiration has been started and while it is being continued, an assistant should loosen any tight clothing about the patient's neck, chest, or waist. TO KEEP THE PATIENT WARM DURING ARTIFICIAL RESPIRATION IS MOST IMPORTANT AND IT MAY BE NECESSARY TO COVER HIM WITH BLANKETS AND WORK THROUGH THEM, AS WELL AS TO APPLY HOT-WATER BOTTLES, HOT BRICKS, ETC. Do not give any liquids whatever by mouth until the patient is fully conscious.
- 8.- To avoid strain on the heart when the patient revives, he should be kept lying down and not allowed to stand or sit up. If the doctor has not arrived by the time the patient has revived, he should be given some stimulant, such as one teaspoonful of aromatic spirits of ammonia in a small glass of water or a hot drink of coffee or tea, etc. Continue to keep the patient warm and at rest.
- 9.- Resuscitation should be carried on at the nearest possible point where the patient received his injuries. As a general rule, he should not be moved from this point until he is breathing normally of his own volition and then

moved only in a lying position. Should it be necessary, due to extreme weather conditions, etc., to move the patient before he is breathing normally, resuscitation should be carried on during the time that he is being moved.

10.- A brief return of natural respiration is not a certain indication for stopping the resuscitation. Not infrequently the patient, after a temporary recovery of respiration, stops breathing again. The patient must be watched, and if natural breathing stops, artificial respiration should be resumed at once.

11.- In carrying out resuscitation it may be necessary to change the operator. This change must be made without losing the rhythm of respiration. The relief operator should kneel behind the one giving the artificial respiration and at the end of the movement, the operator crawls forward while the relief takes his place. By this procedure no confusion results at the time of change of operator, and a regular rhythm is kept up.

RESTRICTED

SERIAL NO. 258

PRELIMINARY
INSTRUCTION BOOK
FOR
NAVY MODEL REW-2
PANORAMIC RADIO ADAPTOR

FREQUENCY
5.25 Megacycles

MAXIMUM SWEEPWIDTH
1 Megacycle

115/230 Volts, Single Phase
50/70 Cycles

"This document contains information affecting the National Defense of the United States within the meaning of the Espionage Act (U.S.C. 50: 31, 32). The transmission of this document or the revelation of its contents in any manner to any unauthorized person is prohibited.

This Instruction Book is furnished for the information of commissioned, warranted, enlisted and civilian personnel of the Navy and persons authorized by the Bureau of Ships whose duties involve design, manufacture, instruction, operation and installation of radio, radar, or underwater sound equipment. The word "Restricted" as applied to this instruction book signified that it is to be read only by the above personnel, and that its contents should not be made known to unauthorized persons not connected with the Navy."

MANUFACTURED FOR
U. S. NAVY DEPARTMENT BUREAU OF SHIPS
BY
PANORAMIC RADIO CORPORATION
NEW YORK, N. Y.

CONTRACT NO. NXss-33781

DATED: June 30, 1943.

"Since the use of high voltages which are dangerous to human life is necessary to the successful operation of the equipment covered by these instructions, certain reasonable precautionary measures must be carefully observed by the operating personnel during the adjustment and operation of the equipment."

"The major portions of the equipment are within shielding enclosures. While every practicable safety precaution has been incorporated in this equipment, the following rules must be strictly observed:

"KEEP AWAY FROM LIVE CIRCUITS. Under no circumstances should any person be permitted to reach within or in any manner gain access to the enclosure with power supply line switches to the equipment closed; or to approach or handle any portion of the equipment which is supplied with power, or to connect any apparatus external to the enclosure to circuits which the equipment; or to apply voltages to the equipment for testing purposes while any portion of the shielding or enclosure is removed or open. Wherever feasible in testing circuits, check for continuity and resistance rather than directly checking voltage at various points."

"DON'T SERVICE OR ADJUST ALONE. Under no circumstances should any person reach within the enclosure for the purpose of servicing or adjusting the equipment without the immediate presence or assistance of another person capable of rendering aid."

"THE ATTENTION OF OFFICERS AND OPERATING PERSONNEL IS DIRECTED TO BUREAU OF SHIPS MANUAL OF ENGINEERING INSTRUCTIONS, CHAPTER 31 (MIMEOGRAPHED FORM) OR SUBSEQUENT REVISIONS THEREOF ON THE SUBJECT OF 'RADIO - SAFETY PRECAUTIONS TO BE OBSERVED.'"

TABLE OF CONTENTS

	<u>Page No.</u>
Electric Shock - First Aid Treatment	1
Title Page	4
Warning Statement	5
Table Of Contents	6
Index to Illustrations and Drawings	7
Contractual Guarantee	8
Failures, Installation, Replacements	9

SECTION I. GENERAL DESCRIPTION

Par: 1.01 - Introductory	10
1.02 - Physical Characteristics	11
1.03 - Dimensions and Weight	12
1.04 - Tube Complement	12
2. - Detailed description of chassis	13
2.01 - Front Panel	13
2.02 - Main operating controls	16
2.03 - Semi-adjustable controls	17
3. - Terms and definitions	18
4. - Theory of Operation	19
5. - Electrical characteristics	23

SECTION II. INSTALLATION AND OPERATION

6. - Preliminary checking procedure	24
7. - Connection of panoramic adaptor to receiver	24
8. - Operating procedure	25
9. - Interpretation of signals	26

SECTION III. MAINTENANCE

10. - Circuit components	29
11. - Servicing Procedure	33
12. - Table of tube socket voltages	41

TABLE I

List of items and parts	42
Key to Manufacturers	55

TABLE II

List of spares	56
----------------------	----

TABLE III

Color Code Charts	60
-------------------------	----

INDEX TO ILLUSTRATIONS AND DRAWINGS

<u>FIGURE</u>	<u>TITLE</u>	<u>PAGE</u>
1 -	Radio Frequency Spectrum	10
2 -	Front View, Panoramic Adaptor	13
3 -	Rear View, Panoramic Adaptor	13
4 -	Top View of Chassis	14
5 -	Bottom View of Chassis	15
6 -	Resolution	19
7 -	Bandpass Characteristic	20
8 -	Overall Bandpass Characteristics	20
9 -	Block Diagram	21
10 -	Power Transformer Connections	34
11 -	Symmetrically Centered Curve	35
12 -	Wiring Diagram	Last Sheet

CONTRACTUAL GUARANTEE

The equipment including all parts and spare parts, except vacuum tubes, batteries, rubber and material normally consumed in operation, is guaranteed for a period of one year from the date of delivery of the equipment to and acceptance by the Government with the understanding that all such items found to be defective as to material, workmanship or manufacture will be repaired or replaced, f.o.b. any point within the continental limits of the United States designated by the Government, without delay and at no expense to the Government; provided that such guarantee will not obligate the Contractor to make repair or replacement of any such defective items unless the defect appears within the aforementioned period and the Contractor is notified thereof in writing within a reasonable time and the defect is not the result of normal expected shelf life deterioration.

To the extent the equipment, including all parts and spare parts, as defined above, is of the Contractor's design or is of a design selected by the Contractor, it is also guaranteed, subject to the foregoing conditions, against defects in design with the understanding that if ten per cent (10%) or more of any such item, but not less than two of any such item, of the total quantity comprising such item furnished under the contract, are found to be defective as to design, such item will be conclusively presumed to be of defective design and subject to one hundred per cent (100%) correction or replacement by a suitably redesigned item.

All such defective items will be subject to ultimate return to the Contractor. In view of the fact that normal activities of the Naval Service may result in the use of the equipment in such remote portions of the world or under such conditions as to preclude the return of the defective items for repair or replacement without jeopardizing the integrity of Naval communications, the exigencies of the Service, therefore, may necessitate expeditious repair of such items in order to prevent extended interruption of communications. In such cases the return of defective items for examination by the Contractor prior to repair or replacement will not be mandatory. The report of a responsible authority, including details of the conditions surrounding the failure, will be acceptable as a basis for affecting expeditious adjustment under the provisions of this contractual guarantee.

The above one year period will not include any portion of time the equipment fails to perform satisfactorily due to any such defects, and any items repaired or replaced by the Contractor will be guaranteed anew under this provision.

"Report of failure of any part of this equipment, during its service life, shall be made to the Bureau of Ships in accordance with current instructions. The report shall cover all details of the failure and give the date of installation of the equipment. For procedure in reporting failures see Chapter 31 (mimeographed form) of the Manual of Engineering Instructions, or Bureau of Ships Radio and Sound Bulletin Number 7, dated July 1, 1942, or superseding instructions."

(a) Contract No. NXss-33781. Date of Contract: June 30, 1943.
Serial Number of Equipment _____
Date of Acceptance by the Navy _____
Date of Delivery to Contract Destination _____
Date of Completion of Installation _____
Date Placed in Service _____

(b) Blank spaces in this book shall be filled in at the time of installation. Operating personnel shall also mark the "date placed in service" on the date plate located below the model nameplate on the equipment, using suitable methods and care to avoid damaging the equipment.



"All requests or requisitions for replacement material should include complete descriptive data covering the part desired, in the following form:

1. Name of part desired.
2. Navy Type number (if assigned) (including prefix and suffix as applicable).
3. Model designation (including suffix) of equipment in which used.
4. Navy Type designation (including prefix and suffix where applicable) of major unit in which part is used.
5. Symbol designation of part.
6. (a) Navy Drawing Number.
7. (b) Manufacturer's Drawing Number
Rating or other descriptive data.
8. Commercial designation.

Section I. GENERAL DESCRIPTION

1.01 Introduction

The Navy Model RBW-2, Type CPN-55090-A panoramic radio adaptor is a new type of electronic equipment which provides additional information for a U.S. Naval radio operator.

Upon connecting the panoramic adaptor to an ordinary radio receiver, the operator will be enabled to see, on a screen, all stations receivable within a 1000 kilocycle band of the station to which he is listening. This band extends 500 kilocycles above and below the frequency to which the receiver is tuned.

The receiver will operate normally and the operator will not only hear the station to which it is tuned, but will also see it and signals of adjacent frequency. This will allow him to intercept quickly any stations appearing on the air, even for short periods of time.

The panoramic adaptor is a device which allows the operator to visualize the radio spectrum on a two-dimensional surface: On the horizontal axis of the screen (base line) frequencies are shown, and on the vertical axis the signal amplitudes are shown. This is illustrated in Fig. 1,

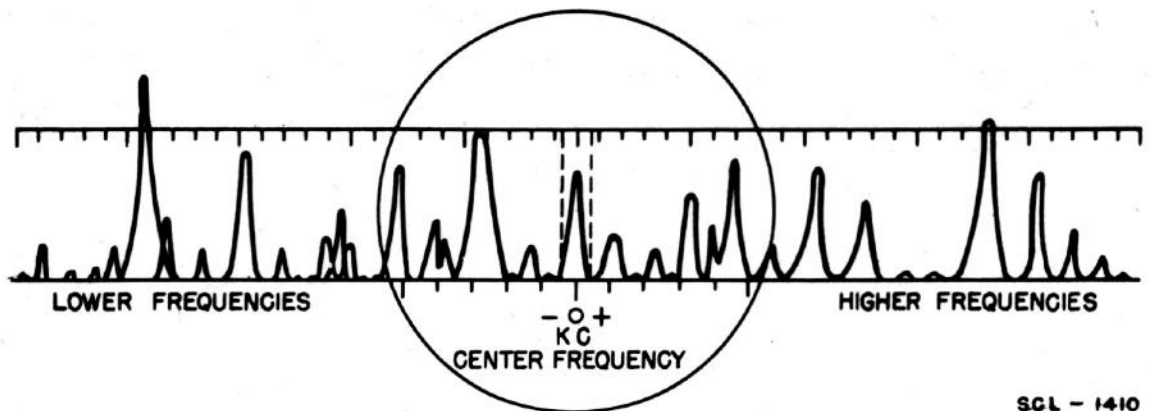

SCL - 1410

FIG. 1 - RADIO FREQUENCY SPECTRUM

The entire strip represents the portion of the radio-frequency spectrum covered by the tuning range of your receiver. The circle in the center represents the range visible on the screen of the panoramic adaptor. The dotted section, directly over the Zero (0) on the scale, represents the signal to which the receiver is tuned. The peaks represent signals or stations. Every signal has its own separate peak or deflection, which tells its own story.

First: It tells the frequency of the signal with respect to the station to which the receiver is tuned, and which is read on the receiver dial.

The screen has a calibrated scale, marked Zero in the center, plus (+) to the right, and minus (-) to the left. Zero represents the receiver dial indication, and each division equals 100 kilocycles.

Taking the frequency reading of the station to which you are listening from the receiver dial, add or subtract the calibration on the screen scale corresponding to the signal peak under observation, and you have the frequency of that signal.

Second: It also tells roughly the strength of the signals that are shown on the screen. The height of each signal peak varies with the strength of the signal, strong signals having high peaks and weak signals having small peaks. With a little experience the operator will be able to judge comparative signal strengths.

Third: It reveals the character of the signal and the type of modulation, whether amplitude or frequency modulation, whether CW, or phone, or pulse, etc.

In case of interference, the screen will tell the nature of the interference, and how to counteract it.

Because the screen shows all of the stations that are on the air, it shows where the clear spots are, so that a transmitter can go on the air without any interference.

The operator must be alert to catch all signals. The panoramic adaptor will help him to spot them, identify them, and tune them in. The enemy tries many tricks to avoid interception and location. Changing frequencies and short, fast signals are among the most common tricks.

1.02 Physical Characteristics

The Navy Model RBW-2 panoramic adaptor consists of accessories and one Type CPN-55090-A panoramic adaptor. The latter with a mounted panel is placed inside a metal cabinet, black wrinkled, with ventilating louvres extending on each side and in the back. The cabinet is mounted on four inverted shock mounts. Four holes only are required to fasten the adaptor to a table or to the top of a radio receiver cabinet. When the unit is shipped it is furnished with a power cable, an input connecting cable, and the few accessories needed to connect the adaptor to an ordinary radio receiver if the receiver has no special provision for panoramic reception. These accessories, consisting of a 25,000 ohms 1/2 watt resistor, a 3/4 inch rubber grommet, and a cable holding clamp, are packed in an envelope. There are also a spare fuse, an Allen wrench and an aligning tool clamped on the top of the chassis.

1.03 Dimensions and Weight:

Over all size:	Width	13 1/2 inches
	Height	8 3/4 "
	Depth	15 "
Panel size:	Width	13 1/4 "
	Height	7 3/8 "
	Depth of Cabinet.	13 "
	Cathode Ray Shield Projection from	
	Front Panel	1 7/8 "
	Distance between bottom of shock	
	mounts and cabinet.	1 3/8 "
	Weight of chassis with tubes.	32 pounds
	Total weight of adaptor	43 "

1.04 Tube Complement

The tubes employed in the Model RBW-2, Type CPN-55090-A panoramic adaptor are as follows:

Symbol (Drawing)	Navy or Commercial Type	Function
V101	6AC7/1852	1st R. F. Amplifier
V102	6SA7	Local Osc. and 1st } Mixer Detector }
V103	6SG7	1st I. F. Amplifier
V104	6SQ7(GT/G)	2nd Det. and 1/2 of push- pull Vert. Amp.
V105	2X2	C.R.T. Power Supply Rectifier
V106	VR105/30	Voltage Regulator for Reactor and Mixer screens and R. F. plate
V107	6AC7/1852	Reactance Modulator
V108	6SL7(GT/G)	1/2 of push-pull Vert. Amplifier. 1/2 of push-pull Hor. Amplifier.
V109	3BP1	Cathode Ray Indicator
V110	6X5(GT/G)	Low Voltage Power Supply
V111	6SL7(GT/G)	Blocking Tube Osc., and 1/2 of push-pull Hor. Amplifier.

2. Detailed Description of the Chassis

2.01 Front Panel

For front panel view, refer to illustration, Fig. 2. Fig. 3 gives a rear view. For top and bottom views of the chassis, refer to illustrations, Figs. 4 and 5. (Pages 14 & 15)

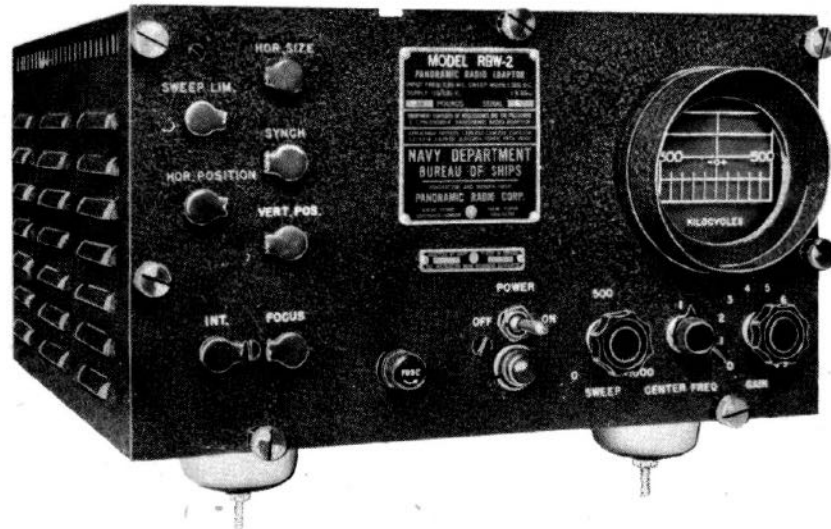

FIG. 2 PANORAMIC ADAPTOR, FRONT VIEW

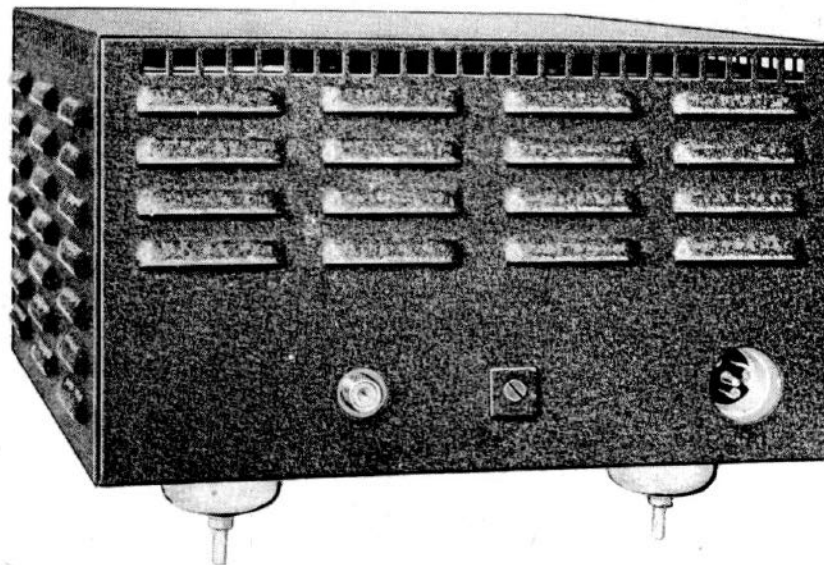

FIG. 3 PANORAMIC ADAPTOR, REAR VIEW

Fig. 2, showing the equipment ready for operation, will be the basis for the ensuing description.

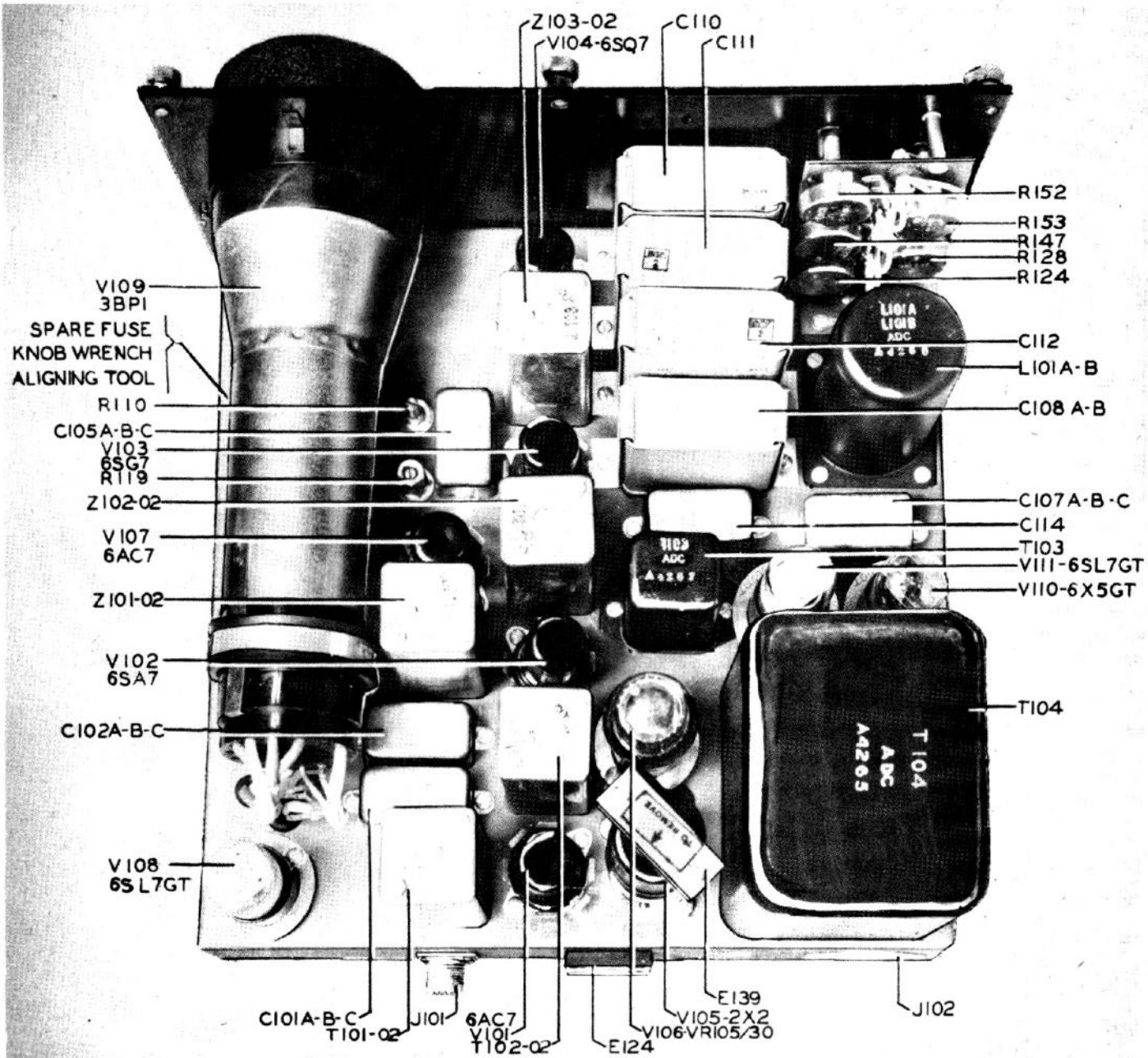

FIG. 4 TOP VIEW OF CHASSIS

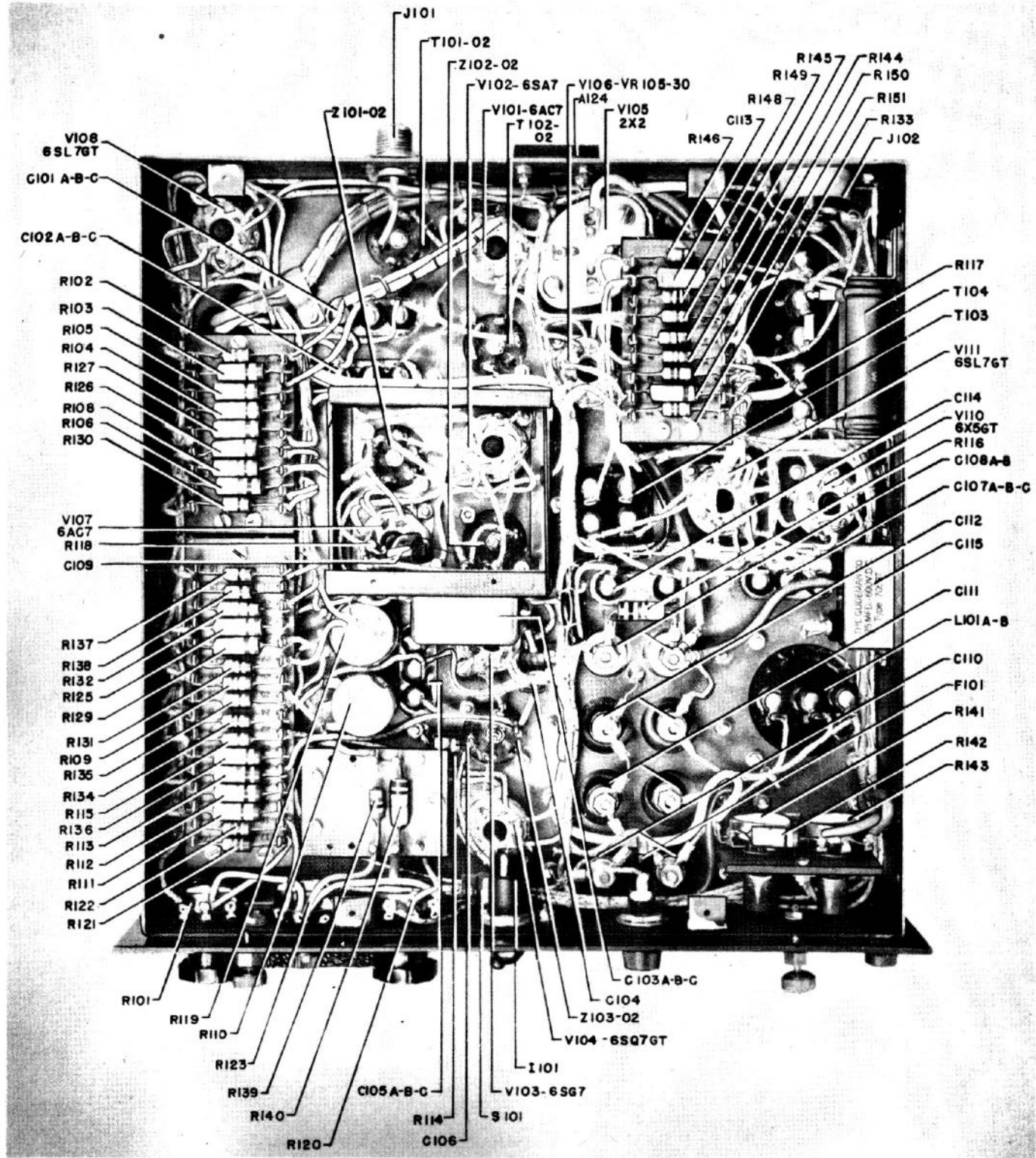

FIG.5 BOTTOM VIEW OF CHASSIS

The power switch is located in the center of the panel and must be turned on, in addition to the receiver's power switch, when operation is desired.

The pilot light is directly underneath. It goes on and off with the power switch.

The fuse, located just to the left of the switch and pilot light, is easily replaceable.

The screen is at the upper right. It is the end of the cathode ray tube which is mounted in the panel in a rubber "boot".

The screen shield. The end of the tube is protected by a green plastic screen shield. This plastic shield protects the tube from damage, and protects the operator from shattered glass if it is hit or if it implodes. **DON'T MAKE THE SCREEN COMPETE WITH A STRONG LIGHT OR SUNLIGHT.** The screen shield is marked with a zero (0) in the center of the horizontal line. On the right of zero is a plus (+) sign, indicating higher frequency than at the center. On the left of zero is a minus (-) sign, indicating lower frequency than at the center. Remember that zero (0) is the frequency to which the companion receiver is tuned.

The screen is calibrated with five equal spaces, right and left of the center. Each line represents 100KC at full sweep of 1000 kilocycles.

Note: When the adaptor is tested alone (i.e., without a receiver) and the signals from a signal generator are fed directly into its input, the operator should remember that the above signs must be reversed.

2.02 Main Operating Controls

SWEEP. This is the sweepwidth control. When this control is turned all the way to the right (clockwise) the maximum band for which the adaptor is designed can be seen on the screen. As this control is turned to the left, the band is made narrower, but the part that can be seen is magnified.

This control is very useful when two or more signals are so close as almost to merge into each other. Then when the sweep is reduced they will seem to separate, and the operator can tune the receiver more accurately.

CENTER FREQ. (Center frequency control). It is desirable to match the adaptor accurately to the receiver. By this it is meant that the signals which are heard in the receiver should come exactly in the center of the base line at its zero mark. Once proper initial alignment has been established, this control is used to maintain or restore the match-condition. The method will be detailed below in Par. 8.05.

GAIN. This controls the R. F. gain of the adaptor and affects the height of the signals shown on the screen. Keep the gain low. Best results can be obtained by keeping the gain as low as possible, while still being able to see a peak on the screen for the weakest signal the operator can hear through the receiver. Keeping the gain low keeps the noise level and the spurious signal level down, and makes it much easier to compare weak signals that are close to strong ones.

2.03 Semi-adjustable Controls (See Fig. 2) On the left of the panel, there are seven snap covers under each of which is a control which can be adjusted by using a screwdriver. Ordinarily these controls are never used, but sometimes they are necessary in adjusting or servicing the equipment. The name of each control is plainly marked on the panel.

Four are marked in white.

Three are marked in red.

Beware of the RED controls. Until the operator thoroughly understands how the set performs the adaptor will be put out of action fast if the controls are moved.

The four white (seldom used) controls are:

- 1.- VERT. POS.:- This adjusts the vertical position of the base line on the screen, which should be very close to the calibration line of the screen scale.
- 2.- INT.:- This controls the intensity or brightness of the line on the screen.
- 3.- FOCUS:- This controls the sharpness of the line on the screen.
- 4.- HOR. POSITION:- This control governs the position of the base line, and is used to bring the signal you hear on the receiver exactly in line with the zero (0) on the scale at full sweep. This control used in conjunction with center FREQUENCY does not have to be used much, but it does permit rapid correction of slight center frequency drift while the receiver or adaptor are cold. See Par. 8.05.

There will be little need for adjusting any of these white marked controls.

The three RED (DON'T TOUCH) controls are:

- 1.- SWEEP PAD:- This control limits the width of the band which is covered.
- 2.- HOR. SIZE:- This controls the length of the base line on the screen, which should be slightly longer than the calibrated scale.
- 3.- SYNCH:- This controls the speed with which the "spot" sweeps across the screen in synchronism with the A. C. power source. Normally, it is set for 30 sweep cycles per second when operating from a 60 cycle source of power, and for 25 sweep cycles when operating from 50 cycles.

3.- Terms and Definitions

Considering the fact that the panoramic adaptor fulfills certain particular functions which are not found in ordinary radio receivers, it becomes necessary to establish certain terms and definitions which apply particularly to this type of radio equipment.

- 3.01 Panoramic Reception is the simultaneous visual reception of several radio signaling stations whose frequencies are distributed over a continuous portion of the frequency spectrum. This definition distinguishes panoramic reception from the conventional reception which can be called "uni-signal" reception and which can be either aural or visual, or both.

The main distinction between panoramic and uni-signal reception is the following: Panoramic reception is periodic reception over a wide range of the spectrum. Each signal is received at fixed, rapid intervals, for a short period of time. (These signals are received so rapidly as to appear to be continuous). Uni-signal reception is continuous reception, of one signal at a time, over a very narrow range of the spectrum.

- 3.02 Companion Receiver is the aural receiver with which the panoramic adaptor is operated.
- 3.03 Sweepwidth is the total band, measured in kilocycles, which can be observed by panoramic reception and which corresponds to the range of frequency sweep of the oscillator in the panoramic adaptor. Sweepwidth should not be confused with signal frequency, although both are measured in the same units (kilocycles).
- 3.04 Base Line is the horizontal line produced on the cathode-ray tube by the sawtooth generator and its associated amplifiers.

Center Frequency is the frequency of a signal which causes a vertical deflection of the base line when the sweepwidth control is set at zero. The center frequency of the panoramic adaptor must be made to correspond to the frequency of the intermediate amplifier of the companion receiver.

- 3.06 Screen Scale is the scale adjacent to the base line, which is calibrated in kilocycles above and below center frequency for a maximum sweepwidth setting.
- 3.07 Deflection Amplitude is the visual equivalent of signal output strength and is represented by the height of a given signal deflection measured from the base line to the tip of the deflection.
- 3.08 Resolution (Fig. 6), is the visual equivalent of selectivity and is represented by the frequency difference between two signals of equal amplitude which intersect 30% down from their peak amplitude. It can be said that the resolution is "better" as this frequency difference decreases.

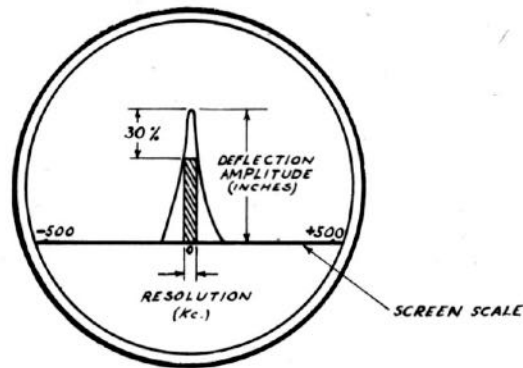

FIG. 6

- 3.09 Sweep Frequency is the frequency of the voltage applied to the horizontal plates of the cathode-ray tube. This voltage has a sawtooth wave shape.

4. Theory of Operation

- 4.01 Companion Receiver:- The companion receiver must be a superheterodyne receiver having an intermediate frequency of 5.25 megacycles.

In the output of the converter tube of a superheterodyne receiver there are signals whose frequencies extend on either side of the I. F. amplifier frequency.

This I. F. amplifier (being very selective) will pass only those signals to which it is tuned, and that is why the operator will hear only one station, in the phones or loud speaker.

4.02

Panoramic Adaptor:- The panoramic adaptor, Navy Model RBW-2 is a complete superheterodyne receiver in itself. The adaptor's input is connected to the output of the mixer tube of the companion receiver. Thus it will receive signals over a relatively wide band. On account of the radio-frequency amplification of the receiver, the signals in the plate of the converter, other than those of its intermediate frequency, will be relatively weak.

The panoramic adaptor has an input-amplifying stage with a bandpass characteristic which is inverse to that of the receiver (See Fig. 7, and 8).). That is, it amplifies where the receiver attenuates, and

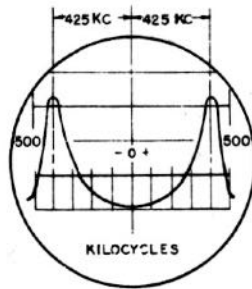

FIG. 7
BANDPASS CHARACTERISTIC

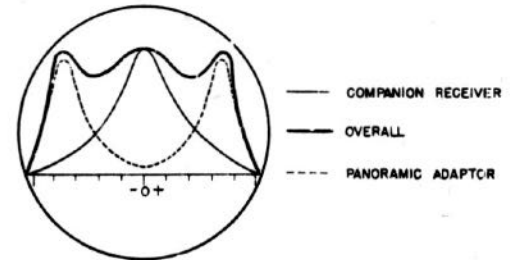

FIG. 8 - OVERALL BANDPASS CHARACTERISTICS

vice-versa. When the two units are used together, the overall bandpass characteristic tends to be uniform through the frequency spectrum. Figure 8, (heavy line) is a view of the approximate variation of amplitude of a signal of constant strength, seen on the adaptor screen, when the receiver is tuned in a region of 5.25 mc. As the receiver is tuned to higher frequencies, the side peaks will tend to increase with respect to the center peak.

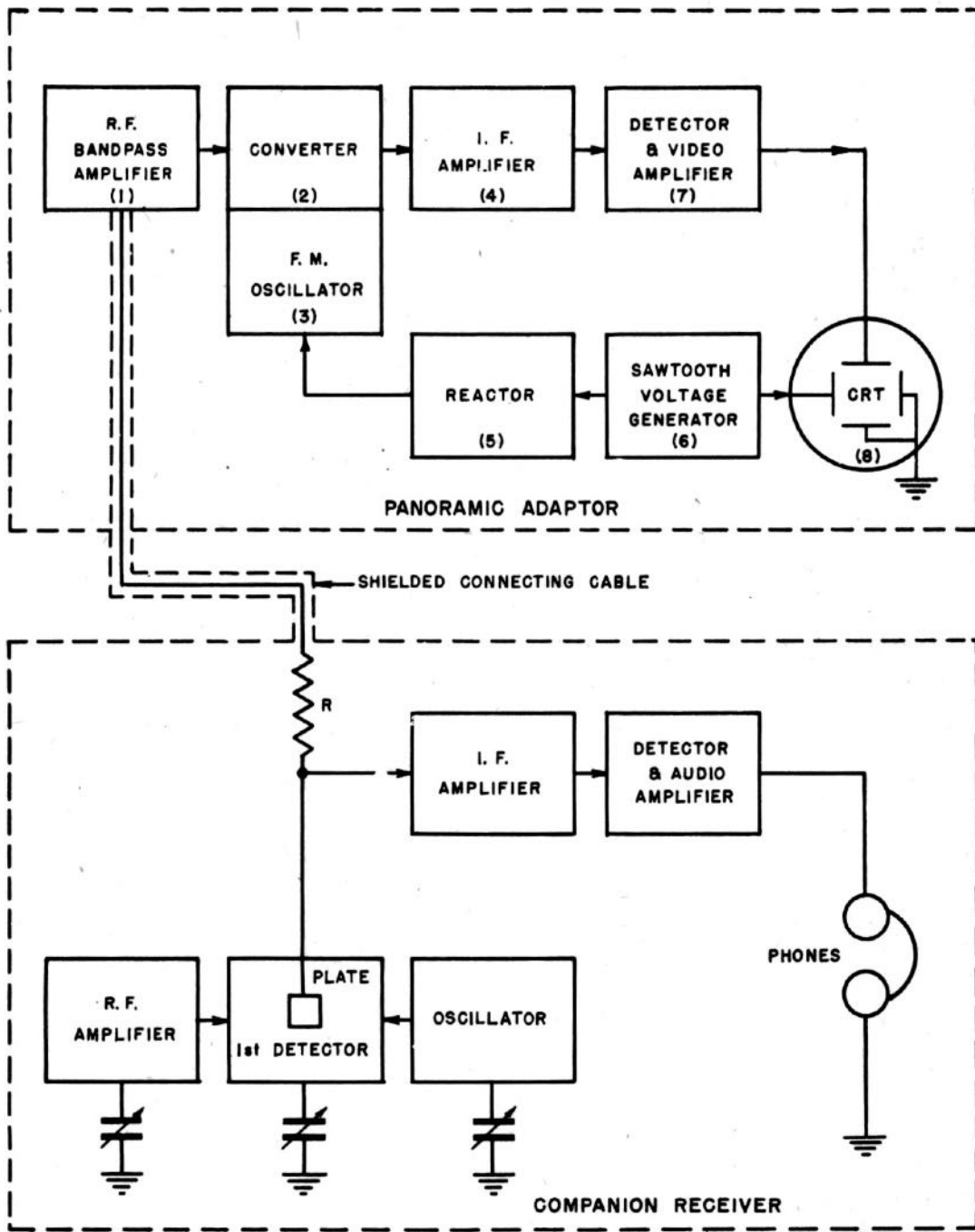

FIG. 9 - BLOCK DIAGRAM

4.03 Bandpass Amplifying Stage. Refer to Block Diagram Fig. 9, for a description of the various steps by which panoramic reception is obtained. Block marked (1) is an R.F. bandpass amplifier (Fig. 7,) which is the input stage of the panoramic adaptor, and is connected to the plate of the first detector of the receiver, through the isolating or blocking resistor "R". This blocking resistor prevents detuning of the receiver and permits the latter to operate normally.

As previously stated, the amplifying characteristic of this R.F. bandpass amplifier is such as to emphasize the bands away from the center frequency, thus amplifying the extremities of the bands more than the center. In this manner we obtain partial compensation for the selectivity of the R.F. or pre-selector stages of the companion receiver. This compensation will vary with the companion receiver's input frequency.

- 4.04 Mixer Stage:- The signals from the R. F. bandpass amplifier are fed into the converter stage (2), where they are mixed with the signals from an oscillator (3).
- 4.05 Oscillator Stage:- This oscillator (3) is frequency-modulated over a frequency range extending equally above and below a mean frequency F_0 at a fixed, rapid rate, extending up to 500KC above and below the mean frequency.
- 4.06 Reactor:- The oscillator (3) is frequency-modulated as stated above. This action takes place entirely by electronic means. A reactance tube (5) forming part of the tuned circuit of the oscillator, varies the frequency of the oscillator in step with a sawtooth sweep voltage applied to its grid.

The mean frequency is adjusted to represent the sum of the receiver's I. F. and the adaptor's I.F. (912KC). Example: If the receiver has an I. F. of 5.25mc., the oscillator mean frequency is of 6.162mc.

The signals from the output of the converter are fed into an I. F. amplifier (4), sharply tuned to 912KC, and from there the signals are detected and amplified into a video amplifier (7). The signals from the output of this amplifier are fed into the vertical deflecting plates of the cathode ray tube (8).

- 4.07 Sweep Generator:- The sweep voltage is supplied by a sawtooth voltage generator (6), thereby effecting a linear frequency excursion, or tuning, of the oscillator. The same sawtooth voltage is also applied to the horizontal deflecting plates of the cathode ray tube. Thus the movement of the cathode ray beam on the screen is synchronized with the tuning of the oscillator.

Remember, however, that each signal appears only periodically, and for only a fraction of the total time. All the signals will give the illusion of being on the screen simultaneously, due to the persistence of the cathode ray screen, retentivity of vision, and rapidity of the horizontal sweep. This must be fully understood to facilitate the operator's interpretation of the signals seen.

More complete details as to the functioning of every circuit of the panoramic adaptor are given in Section III (Maintenance).

5. ELECTRICAL CHARACTERISTICS
of Navy Model RBW-2
Panoramic Adaptor
Type CPN-55090-A

General

Maximum Sweepwidth	1000KC
Input Frequency	5.25mc.
Blocking Resistor required	25,000 ohms
Power Source required	115/230 V. 50/70 cycles AC
Bandpass Amplifying Stage Peak Frequencies	4.825mc. \pm 100kc., of 5.675mc. these freq.
Peak to center amplitude ratio: greater than -	5:1
Sensitivity Deflection amplitude for a 5.25mc. signal of 200 microvolts applied through the coupling resistor	more than 1/4" deflection
I. F. Transformers adjusted to	912KC. (approx.)
Oscillator mean frequency (Sweepwidth reduced to zero)	6.162mc. (approx.)
Oscillator Swing up to	\pm 500KC.
Sweep Frequency Adjustment	30 cycles
Sweep Voltage Waveform	Sawtooth Linear

SECTION II- INSTALLATION AND OPERATION

6- Preliminary Checking Procedure

The adaptor is wired for a 115/230 volt, 50/70 cycles single phase, alternating current, power source. BE SURE TO HAVE THIS POWER AVAILABLE. The power connections set at the factory are for 115 volt operation. For 230 V. see Fig. 10. , page 34.

After removing the adaptor from its packing case, attach the power cable which plugs into a receptacle on the back of the chassis. The plug is polarized (see Fig. 3, page 13.). A right turn locks it. Now make a little preliminary check on the adaptor before connecting it to the receiver:-

- (a). Turn the power switch on. The pilot light should go on at once, AND IN HALF A MINUTE THE BASE LINE SHOULD APPEAR ON THE PANORAMIC SCREEN.
- (b). Turn GAIN control fully on - clockwise. The base line will show "bumps", particularly near each end. It is noise - and O.K.
- (c). Turn GAIN fully off - counterclockwise. The base line should be clear and clean from one end to the other.

7. Connection of Panoramic Adaptor to Receiver

Find the proper place for the adaptor. If possible do not mount adaptor over ventilation holes of companion receiver.

- (a). Make sure the RECEIVER has an intermediate frequency which corresponds to the input frequency of the adaptor.
- (b). Disconnect both adaptor and receiver from the power line.
- (c). The co-axial cable supplied with the equipment has a male plug at one end. That end fits into the input female receptacle in the rear of the adaptor. The other end must be connected to the plate of the receiver's mixer tube (first detector) with the 25,000 ohm resistor, in series.

NOTE: IF THE COMPANION RECEIVER IS NOT PROVIDED WITH A RECEPTACLE FOR OPERATION WITH A PANORAMIC ADAPTOR, PROCEED AS FOLLOWS:

Drill a 3/4" hole through the receiver cabinet, somewhere near the plate prong of the mixer tube, and fit the rubber grommet supplied with the equipment into the hole.

Connect the 25,000 ohm resistor supplied, as closely as possible to the plate prong of the receiver's mixer tube

(first detector).

Insert the free end of the co-axial cable through the hole with a grommet, and connect the inside conductor to the other end of the 25,000 ohm resistor. Connect the outside of the cable (shield) through the cable clamp provided with equipment, to the receiver chassis, and make sure you have a good ground connection.

Now the other end of the co-axial cable, with the plug, may be inserted into the receptacle in the rear of the panoramic adaptor.

If desired, there may be installed in the receiver a permanent co-axial cable with its blocking resistor, and terminated in a standard Navy #CPH-49194 female connector (as in the adaptor). To this can be attached a panoramic cable and plug #CPH-49193. In this case the panoramic input cable must be shortened by the amount of co-axial cable used in the receiver.

8. Operating Procedure

Now that the receiver and the adaptor are connected, they are ready to operate as follows:

- 8.01 Again plug in both receiver and adaptor power cords. Turn on the receiver - and check its operation.

NOTE:- The antenna should remain connected to the receiver in the normal manner.

- 8.02 Turn on the adaptor and wait for the base line to appear.

- 8.03 Turn "GAIN" control up about half way.

- 8.04 Slowly tune the receiver and soon there will be one or more signals appearing on the panoramic screen, moving across it.

- 8.05 Tune in any station on the receiver, using phones or speaker. The signal should appear on the panoramic adaptor screen **DIRECTLY** over the zero (0), that is, exactly in the center of the scale. For best results it is advisable to adjust the mean frequency of the panoramic adaptor oscillator, to give a signal which remains in the center of the screen, no matter what is the position of the "SWEEP" control. (This should be done after the adaptor has been allowed to warm up).

The above adjustment is accomplished by turning the "SWEEP" control fully counterclockwise and then centering the deflection peak by rotating the "CENTER FREQ." knob. Turning the "SWEEP" full clockwise should now leave the peak at the zero mark on the screen; if not, adjust **HOR. POSITION**

control. The "CENTER FREQ." control knob has purposely been made small and placed between two larger knobs where it will not interfere with operation of the other two controls. It must be clearly borne in mind by the operating personnel that this control should be adjusted only infrequently. Incorrect adjustment of the "CENTER FREQ." control will result in throwing the adaptor out of alignment with the companion receiver, as far as "CENTER FREQ." is concerned.

9. Interpretation of Signals

With a little experience, the operator will be able to visually recognize the character of the various types of signals, without the need of listening to them. It must be remembered, however, that the panoramic radio adaptor can show only what the radio receiver is able to receive and no more. A poorly adjusted receiver cannot be expected to give good results even with a perfectly adjusted adaptor.

- 9.01 A constant carrier appears as a deflection of fixed height.
- 9.02 An amplitude modulated carrier appears as a deflection of variable height. Voice or music modulation causes the carrier to vary irregularly. A constant tone modulation of low frequency will produce a series of convolutions varying in height, their number being determined by the modulation frequency.
- As the modulation frequency increases the convolutions move toward the two sides of the deflection, as the side-bands tend to become visible. When the modulation frequency is increased, it becomes possible to separate the two side-bands by reducing the sweepwidth of the adaptor. The higher the frequency of modulation, the farther away these side-bands will move from the center deflection, representing the carrier. One should remember, that due to possible non-linear amplification of the receiver, or of the adaptor, or both, over a wide band, the two side-bands may appear unequal in height, even though they are of equal strength. Their relative heights may vary as the receiver is tuned and as the deflection moves from one end of the screen to the other.
- 9.03 Single side-band modulation appears as two carriers of slightly different frequency (See below: "Signal Interferences").
- 9.04 A frequency modulated carrier appears as a carrier which is "wobbling" sideways.
- 9.05 A speech or music modulation FM signal appears as a multiplicity of deflections spreading over a variable bandwidth. During periods of silence a single carrier appears.
- 9.06 A CW signal appears and disappears in step with the keying of the transmitter. During the moments when the signal is off, the frequency sweep axis closes at the base of the signal. A radio operator used to

reading CW signals on phones can, with a little practice, read such signals directly off the screen. In very rapidly keyed signals the deflection and the base line are seen simultaneously.

A MCW signal appears like a CW signal of periodically varying height. If the modulation rate is high, sidebands will appear as explained above.

9.07 Signal Interference. Two signals which are so close in frequency as to cause aural interference (beats), may appear on the screen as a single deflection, varying in height as with a modulated signal. As the frequency separation is increased, the deflection appears as if modulated on one side only. Further increase of frequency will cause a "break" in the apex of the deflection. By reducing the sweepwidth of the adaptor, the respective deflections will gradually separate.

9.08 Transient disturbances, generally received as noises in the receiver, are of two types: periodic and aperiodic transients.

Periodic transients, such as produced by automobile ignition, motors, vibrators, buzzers, etc., appear as signals moving along the frequency sweep base line in one direction or another. Thus, an automobile, which is accelerating will produce a set of deflections which may move first in one direction, slow down, stop, and then move in an opposite direction. This is caused by the fact that the adaptor is sweeping at a fixed rate (30 times per second), whereas the transient occurs at a variable rate. The images stand still on the screen when there is synchronism between the two. If the transient disturbance is synchronized with the 60 cycle line the "noise" appears as fixed signal which, however, does not move on the screen when the receiver is tuned, but only varies in height. Such deflections may appear like amplitude modulated signals or like steady carriers. (See below: "Diathermy apparatus"). Aperiodic transients, such as "static" appear as irregular deflections and flashes along the whole frequency sweep axis.

9.09 Tube noises, due to too great an amplification of the receiver, or adaptor, or both, appear as varying irregularities along the frequency sweep axis. Proper adjustment of the gain controls should reduce or eliminate this disturbance.

9.10 Images. If the receiver allows "images" to pass (due to poor image rejection of the R.F. circuits) these will be distinguishable from normal signals by the fact that they move in an opposite direction with respect to normal signals on the screen of the panoramic adaptor when the companion receiver is being tuned. Such images are most likely to appear on the higher frequency ranges of the receiver.

- 9.11 Harmonics, produced in the receiver by the beat of very strong signals with harmonics of the oscillator, will be distinguishable from other signals by the fact that they move on the screen more rapidly (with tuning) than the normal signals. (Twice as fast for second harmonic spurious signals). Generally, a reduction in the gain of the receiver will eliminate this type of spurious signal.
- 9.12 Diathermy apparatus using an unfiltered or A.C. power supply will produce a periodic disturbance which will cause a deflection to appear on certain portions of the screen and disappear on other portions. This is due to the fact that such equipment emits a signal pulsating in synchronism with the power line. On the other hand, the adaptor too, is sweeping the spectrum in synchronism with the line, but at a lower frequency (30 cycles) and only when a certain phase relationship exists is it possible for the adaptor to receive those periodic pulses.
- 9.13 Spurious Signals. If the signal strength exceeds a certain value, the deflection caused by any signal breaks up into a series of parallel deflections, somewhat similar to side-bands. These spurious signals can take place either in the receiver or adaptor on extremely strong signals. A slight reduction in the gain of the adaptor will eliminate this type of distortion.
- 9.14 Use of the A.V.C. of the receiver. When the receiver is using A.V.C., the signal appearing in the center of the screen will control the height of all other signals. If the receiver is tuned to a strong signal, the weaker adjacent signals will be reduced in height or may not appear at all. It may be found expedient, in most applications, to operate the receiver with the A.V.C. cut off.

REMEMBER THESE POINTS

1. Always look to see what voltage is available before plugging in your Adapter. If it is more than 115 volts, (220V,) you'll have to change the primary connections of your power transformer before plugging in.
2. If you've put the Adapter on top your radio, look again to make sure you haven't put it over the ventilation holes. Your set must "breathe".
3. The station your radio is tuned to is always *seen* in the center of the Adapter screen.
4. Don't compete with sunlight. Shade your screen. You'll spot stations much easier.
5. KEEP your GAIN control as low as you can and still see a peak on your screen for the weakest signal you can hear.
6. Don't touch the seven semi-adjustable controls while you are operating. They are only for servicing. NEVER touch the four red controls even for servicing, unless you're sure you know all about the outfit.
7. Don't let rain or water get into your set. Keep it dry. Moisture may ruin it.
8. And last but not least—look out for the 1,000 volts inside your set! It's hot!

SECTION III - MAINTENANCE

10. Circuit Components

10.01 Input Bandpass Transformer

T101-02 is the input bandpass transformer, containing two windings (A and B), permeability-tuned by means of iron cores, which can be reached from the top and from the bottom of the chassis, respectively. It is connected to the grid of V101, a 6AC7, which is the bandpass amplifier tube. This transformer is tuned to pass a band centered at the receiver's I. F. (5.25mc.) and extending 500KC on each side.

10.02 Gain Control

Potentiometer R101 which is connected in the cathode of the V101 tube, is the GAIN CONTROL of the panoramic adaptor.

10.03 Output Bandpass Transformer

T102-02 is the output bandpass transformer containing two windings (A and B), permeability-tuned by means of iron cores, and is connected to the grid of V102. It is tuned in the same manner as T101-02 from the top and from the bottom of the chassis, and to the same frequency.

10.04 Mixer-Oscillator Tube

Tube V102, (6SA7, functions as the mixer and oscillator.

10.05 Composite Coil

Transformer Z101-02 is a composite coil. It consists of the coil used in the tuned circuit of the oscillator, a resistance-capacity phasing network, and a choke coil. To facilitate interchangeability of this very critical circuit, all the components have been wired into a single shielded container. This composite coil is connected between the reactor tube, V107 (see below), and the mixer-oscillator tube V102.

The proper mean frequency F_o , of the oscillator is the sum of the intermediate frequencies of the receiver and of the adaptor. (See Theory of Operation, Par. 4.06). Tuning is usually obtained by adjustment of the panel control marked "CENTER FREQ." as described in Par. 8.05 above. However, in extreme circumstances, it may be necessary to re-align the adaptor by tuning the F. M. oscillator coil from the top of the chassis. This will be detailed below, Par. 11.032a.

10.06 Reactor Tube

The reactor tube, V107, is a 6AC7. A potentiometer, R119, marked REACTOR PAD, connected in the cathode, serves to adjust the panoramic adaptor for a linear frequency sweep at the correct center frequency. This pad is mounted on the chassis near the cathode-ray tube. It has been set at the factory. Unless the panoramic adaptor has been serviced this pad will need no adjustment.

If V107 has to be replaced by another 6AC7 tube, there may result a change in frequency on account of the variation in characteristics of the two tubes. This may be offset by resetting either the REACTOR PAD or the zero adjustment in Z101-02.

NOTE: DO NOT ADJUST THIS CONTROL BEFORE YOU BECOME THOROUGHLY FAMILIAR WITH SERVICING PROCEDURE.

10.07 Sweep Voltage Generator

The sweep, or sawtooth voltage generator, is an oscillator, of the B.T.O. (blocking tube oscillator) type. It is composed of B.T.O. transformer T103, one-half of tube V111, and potentiometer R147.

Tube V111 is a 6SL7-GT double triode. One-half of the tube is used to generate the sawtooth voltage, which is then applied to a push-pull amplifier consisting of the other half of V111 and of one half of V108 which is another 6SL7-GT tube.

This circuit is capable of generating a sawtooth voltage of any frequency between 20 and 40 cycles. A certain amount of alternating current is fed into the grid of the V111 tube from the filament winding of the main power transformer T104, in order to "lock" the sweep frequency to a sub-multiple of the line frequency. That is - if the A. C. line frequency is 60 cycles per second, the sweep frequency is locked at 30 cycles; if the A. C. line frequency is 50 cycles or 25 cycles per second, the sweep frequency is locked at 25 cycles.

10.08 Sweep Frequency

The potentiometer R147, is the semi-adjustable control (front panel) marked in red, SYNCH. This resistor regulates the blocking of the sawtooth generator, and, therefore, the frequency of the sawtooth voltage.

10.09 Sawtooth Voltage Amplitude

The output from the sawtooth generator half of tube V111 is fed through a coupling capacitor C114, to potentiometer R152.

The latter is a semi-adjustable control marked in red, "HOR. SIZE". This potentiometer controls the amount of sawtooth voltage applied to the grid of the horizontal amplifier section V111. The greater the amplitude of the sawtooth voltage, the longer the horizontal base line.

The output from this section of V111 drives one horizontal deflection plate of cathode ray tube, V109, and also passes through fixed resistor, R133, to drive the grid of one section of tube, V108. The output from this half of the pushpull horizontal amplifier drives the remaining horizontal deflection plate in V109 in phase opposition to the voltage driving the other horizontal deflection plate.

10.10 Sweepwidth Control

The sweepwidth control, R120, (SWEEP) regulates the amplitude of the

sawtooth voltage applied to the grid of the reactor tube. When the sweep voltage is reduced to zero, the reactor tube will no longer affect the oscillator, and therefore this oscillator will operate only at its mean frequency, F_0 .

The sawtooth voltage developed across the cathode follower of the sawtooth voltage amplifier is fed through a coupling capacitor C115 to the two potentiometers R153 and R120, in series.

10.11 Sweepwidth Limiter

R153 is a semi-adjustable pad (front panel). "SWEEP LIM." is so adjusted that, with R120 (SWEEP) at its maximum value (full clockwise position) the sweepwidth is equal to 1000 kilocycles.

The panel in front of the control knob for R120 is engraved 0, 500, 1000KC. The calibration at 500 is approximate, at 1000 is accurate.

10.12 I. F. Amplifier Stage

This stage consists of an input I. F. transformer Z102-02, a V103 tube 6SG7, and an output I. F. transformer Z103-02. These transformers are tuned to 912KC, and are set for critical coupling.

10.13 Sensitivity Limiter

Sensitivity is limited by the potentiometer R110, which varies the screen voltage of the I. F. amplifying tube V103 (6SG7). This pad, marked I. F. PAD, is mounted on the chassis beside the REACTOR PAD. It has been set at the factory. Reserve gain has been built into this section of the circuit. In the event that the overall gain diminishes as the tubes weaken, it is possible by adjusting the I. F. PAD to bring up the gain without inserting new tubes.

The microvolt input (through the coupling cable and isolating resistor) necessary for a 1/4 inch deflection at the center of the screen (with the GAIN control on full) is the sensitivity of the panoramic adaptor. Do not give more sensitivity than required. Too much sensitivity will make the adaptor screen appear "noisy."

10.14 Detector and Video Amplifier

Tube V104 (6SQ7) is a diode and triode in one envelope. The diode is used as the detector, and the triode is used as one of the video amplifiers. Direct coupling is used between the detector, the video amplifiers, and the vertical deflecting plates of the cathode-ray tube, V109 (3BP1).

10.15 Vertical Positioning Control

The resistor, R124, serves to position the base line vertically.

It is a semi-adjustable control marked in white, VERT. POS .

10.16 Horizontal Positioning Control

The resistor, R128, serves to position the base line horizontally. It is a semi-adjustable control marked in white, HOR. POSITION .

10.17 Cathode-Ray Tube

The cathode-ray tube V109 -(3BP1) consists of a number of elements operating at high potentials. When the potentials are applied in a proper ratio they cause the electrons emitted from the cathode to be accelerated to a high velocity and focused into a sharp beam. This high velocity electron beam continues toward the face of the tube, striking a phosphorescent coating, and causing a green glow to appear as a dot on the screen of the cathode-ray tube. There are two sets of parallel plates in the cathode-ray tube; one set causes the beam (green dot) to be deflected in a horizontal direction, the other set causes the beam (green dot) to be deflected in a vertical direction.

As a result of these deflections, which are very rapid, the moving beam will trace a continuous pattern on the screen of the cathode-ray tube.

10.18 Intensity Control

Resistor R143 is used to control the brightness of the trace on the screen. This control is semi-adjustable and marked in white, INT.

10.19 Focus Control

Potentiometer R141 is used to control the sharpness of the trace on the screen. This control is semi-adjustable and marked in white, FOCUS .

10.20 Power Supply

The power supply of the panoramic adaptor, Navy Model RBW-2, consists of a main power transformer T104, and two rectifying tubes V105 (2X2) and V110 (6X5GT). The power transformer is normally wired for 115 volts.

The high voltage rectifier (V105) provides the necessary voltages to the cathode-ray tube. The output of the low voltage rectifier (V110) is filtered by chokes L101A and L101B and capacitors C110, C111 and C112. The filtered output from the low voltage rectifier feeds a voltage regulating tube V106 (VR-105-30). This regulated 105 volt output supplies the plate voltage for V101, and the screen voltages for V102 and V107.

11. Servicing Procedure

CAUTION:- OPERATION OF THIS EQUIPMENT INVOLVES THE USE OF HIGH VOLTAGES WHICH ARE DANGEROUS TO LIFE. OPERATING PERSONNEL MUST AT ALL TIMES OBSERVE ALL SAFETY REGULATIONS. DO NOT CHANGE TUBES OR MAKE ADJUSTMENTS INSIDE EQUIPMENT WITH HIGH VOLTAGE ON. UNDER CERTAIN CONDITIONS DANGEROUS POTENTIALS MAY EXIST IN CIRCUITS WITH POWER CONTROLS IN THE OFF POSITION DUE TO CHARGES RETAINED BY CAPACITORS, ETC. TO AVOID CASUALTIES ALWAYS REMOVE POWER, DISCHARGE AND GROUND CIRCUITS PRIOR TO TOUCHING THEM.

11.01 Equipment Required for Servicing

In order to service the panoramic adaptor, the following equipment should be available:

- (a) Volt-ohmmeter (at least 1000 ohms per volt).
- (b) Signal generator to cover a range of 200 KC. to 6000 KC.
- (c) In addition, a 10KC and a 50KC multi-vibrator will considerably simplify the alignment procedures.
- (d) A cathode ray oscillograph is optional, but will be needed if it is desired to examine the sawtooth voltage form.

11.02 Miscellaneous Data

11.02-1 Removal of chassis from the cabinet:

- a.- Disconnect the power cable from the A. C. line. Then, at chassis end of cable, rotate plug to lift and disengage.
- b.- Disconnect the input cable, by unscrewing the connector at chassis end of cable.
- c.- Unfasten the seven panel thumbscrews and the screw in center rear of cabinet.
- d.- Grasp two of the thumbscrews on the panel and pull forward.

11.02-2 Removal of cathode ray tube.

- a.- Loosen the clamp which supports the tube and shield.
- b.- Lift the spring fingers of the shield which are on the lip of the socket.
- c.- Grasping the tube and shield in one hand, remove the socket with the other hand. (A prying tool may have to be used here).

- d.- Grasp the tube and shield with one hand, and ease it out through the metal hood or shield which forms part of the front panel. Note that the cathode-ray tube is protected by a sponge rubber boot, which will come out with the tube when it is removed. The boot also serves to hold in place the calibrated green filter screen.
- e.- Remove boot simply by pulling it off the cathode-ray tube. The tube will then come out of the shield.

11.02-3 Power transformer connections

The power transformer may be connected for 115 or 230 volt, 50-70 cycle operation. For 115 volt operation connect winding 3-9 in parallel with winding 4-10. For 230 volt operation connect windings 3-9 and 4-10 in series. See diagram Fig. 10.

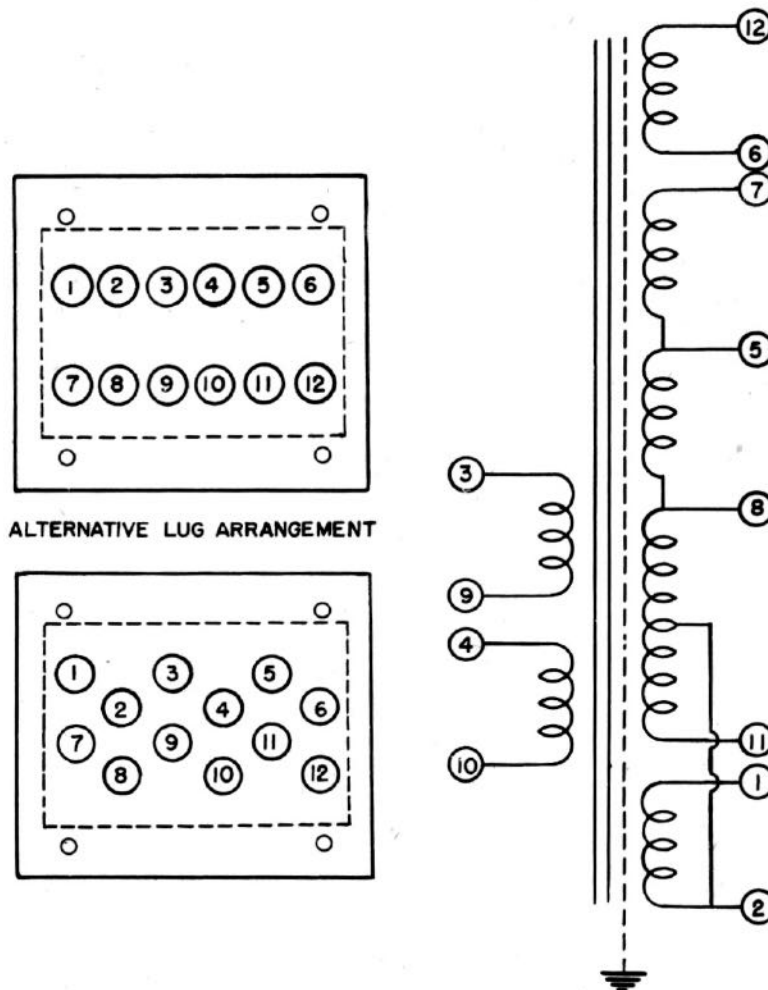

FIG.10 - POWER TRANSFORMER CONNECTIONS

11.02-4 Tuning the R.F., I.F. and F.M. Oscillator Coils

Transformers T101-02, T102-02, Z101-02, Z102-02, Z103-02 are tuned by means of movable iron cores. Windings "A" can be tuned at the top of the coils by means of the tuning tool which is provided in the accessory kit of the panoramic adaptor. Use the end which has a pin passed through the bakelite rod. Windings "B" can be tuned either from the top of the transformer or from the bottom. In either case a screwdriver tip is required. When the tuning is done from the top, use the other end of the tuning tool, which is ended as a screwdriver, and insert it through the opening of the core. The iron slugs of windings "B" have a slot provided for the purpose.

11.03 Alignment Procedure

(First: Allow equipment to warm up for at least 1/2 hour).

NOTE:- When the panoramic adaptor is used in conjunction with a companion receiver, the (+) sign on the calibration screen indicates high frequency, and the (-) sign on the calibration screen indicates low frequency; but when the signals are fed directly into the adaptor (as from a signal generator), the (+) sign indicates low frequency, and the (-) sign indicates high frequency. The following adjustments are made with a signal generator having a band of frequencies of 200 to 6000KC.

11.03-1 I. F. Amplifier Alignment

The I. F. amplifier frequency for the adaptor is 912KC.

- a.- Using the signal generator, feed 912KC into the grid (pin 4) of tube V103 (6SG7). Adjust the cores of the second I. F. transformer (Z103-02) for the highest vertical deflection obtainable on the screen of the cathode-ray tube.

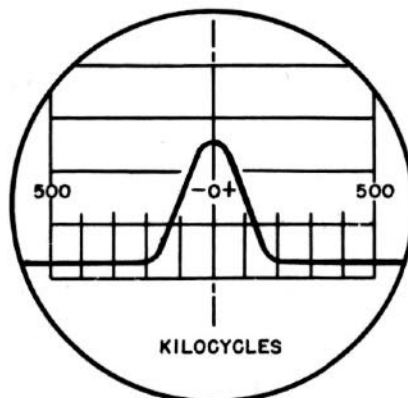

FIG. II- SYMMETRICALLY CENTERED CURVE

- b.- Feed 912KC into the grid (pin 8) of tube V102 (6SA7). Adjust the cores of the first I. F. transformer (Z102-02) for the highest vertical deflection obtainable on the screen of the cathode-ray tube. The picture on the screen should look as Fig. 11.

11.03-2 Frequency Modulated Oscillator Alignment

The following adjustments are a series of approximations, which are generally narrowed down until the desired results are obtained. During the entire procedure the signals are fed to the input of the panoramic adaptor through the cable and 25,000 ohm isolating resistor.

a.- Center Frequency Alignment

Generally the adjustment of the "zero" control is sufficient. If, however, all controls are out of adjustment proceed as follows:

- 1.- A 5.25mc. signal is used.
- 2.- Set the SWEEP control at maximum.
- 3.- Set the CENTER FREQ. control at the panel marker.
- 4.- Adjust the ZERO on transformer Z101-02 so that the deflection on the cathode-ray tube screen is approximately centered. In order to achieve centering, it also may be necessary to adjust REACTOR CATHODE control R119 until the deflection appears on the screen at -500KC. Make this adjustment as a last resort. (Some adjustment of SWEEP LIM., E153, may be necessary.)
- 5.- Now gradually rotate the SWEEP control (R120) counterclockwise towards its minimum position. At the same time continue readjusting the ZERO control for a centered deflection.
- 6.- The Panoramic adaptor is properly adjusted for center frequency when, with the SWEEP control (R120) set just above its minimum position, a symmetrically centered curve appears on the screen. (Fig. 11)
- 7.- Rotate SWEEP control (R120) to maximum. If the deflection fails to remain centered the HOR. POSITION control (R128) should be used.

- 8.- In order to achieve a symmetrical curve it may be necessary to readjust the I. F. alignment slightly.
- b.- High Frequency Alignment.
- 1.- A 5.75 mc. signal is used.
 - 2.- Set SWEEP control (R120) at maximum.
 - 3.- Adjust REACTOR PAD (R119) until the deflection appears on the screen at -500 KC. Some adjustment of SWEEP LIM. (R153) may be necessary.
- c.- NOW repeat Operation a, above (Center Frequency Alignment).
- d.- Low Frequency Alignment.
- 1.- A 4.75mc. signal is used.
 - 2.- Set the SWEEP control (R120) at maximum.
 - 3.- Adjust SWEEP LIM. (R153) until the deflection appears on the screen at +500KC.
- e.- AGAIN repeat Operation a, above (Center Frequency Alignment).
- f.- NOW repeat Operation b, above (High Frequency Alignment).
- g.- NOW repeat Operations a, b and d, above.
- h.- FINALLY repeat Center Frequency Alignment Operation.

NOTE

For the above alignment procedure of the oscillator, only a signal generator is required. This alignment procedure is greatly simplified if a multivibrator is used in conjunction with the signal generator, because the signals can be seen simultaneously, on the high and low frequencies, as well as the center. The multivibrator is a 50KC oscillator, preferably accurately controlled by a 100KC crystal oscillator. Since the multivibrator is very rich in harmonics, it supplies a multitude of signals every 50 or 100KC. When the F-M oscillator is correctly aligned, 100KC signals will show eleven deflections at intervals of one division between divisions.

11.03-3 R. F. Alignment

For this alignment, a "cut-and-try" method again is required. Figure 7, illustrates a properly aligned bandpass. (Page 20.)

The use of a multivibrator having any frequency between 2KC and 15KC, greatly simplifies alignment, making it possible to view as one complete picture the entire bandpass characteristic of the R.F. amplifier. It is possible to align the R.F. amplifier stage using only a signal generator. In order to obtain the trace illustrated in Figure 7, the frequency of the signal generator is varied so that the peaks of the deflection on the screen move from one end to the other to produce this trace.

a.- Procedure for alignment of the R.F. bandpass transformer with the use of the multivibrator:

- 1.- Feed the multivibrator to the input of the adaptor through the cable and a 25,000 ohm resistor.
- 2.- Adjust the cores of the R.F. transformers T101-02 and T102-02 until the trace approximates that shown in Figure 7, (Page 20.)

b.- Procedure for the alignment of the R. F. bandpass transformers using the Signal Generator:

1.- Align first the Interstage Transformer T102-02.

- (a).- Feed a 5.25 mc. signal to plate (pin 8) of R.F. amplifier tube V101 (6AC7) through .01 mfd. coupling capacitor and adjust secondary (B) for peak deflection at the center of the screen.
- (b).- Now feed a 5.68mc. signal into the grid (pin 4) of the R.F. amplifier tube V101 (6AC7) and tune primary (A) for peak deflection at the left of the screen.
- (c).- With the signal generator still being fed into the grid (pin 4) of the R.F. amplifier V101 (6AC7) retune the secondary (B) at a frequency of 4.83mc. for peak deflection at the right side of the screen.

2.- Align next the Input Transformer T101-02

(a).- Feed a 5.25mc. signal to primary (A) of T101-02 through the 25,000 ohm isolating resistor and the input cable of the adaptor. Adjust secondary (B) for peak deflection at the center of the screen.

(b).- Now feed a 5.68mc. signal to the end of input cable of the panoramic adaptor through a 25,000 ohm isolating resistor and adjust primary (A) for peak deflection of the left side of the screen.

(The capacity of the cable is part of the primary circuit.)

(c).- With the signal generator still being fed to the input cable of the panoramic adaptor, retune the secondary (B) at a frequency of 4.83mc. for peak deflection at the right side of the screen.

(d).- NOW trim the primaries and secondaries of both R.F. transformers until the desired peak deflections are nearly of equal amplitude and appear approximately 400KC (4 divisions) from the center mark.

11.04 Synchronization of Sweep Frequency

The frequency of the sawtooth voltage is adjusted by a semi-adjustable control, R147, to a sub-multiple of the A.C. line frequency. The standard frequency for the adaptor is 30 cycles when used with a 60 cycle line, and 25 cycles when used with a 25 or a 50 cycle line.

In order to check this adjustment, A.C. line voltage can be obtained from pin #7 of tube V104 and fed through a 5,000 mmf. coupling capacitor to pin #6 of tube V104. Two peaks will appear on the screen if the sweep frequency is one-half of the line frequency (in case of 50 and 60 cycles). One peak only will appear when the frequency is correct, from a 25 cycle power line.

11.05 I. F. gain Limiter Adjustment
(TO BE DONE ONLY BY EXPERIENCED PERSONNEL)

- 1.- The GAIN control and the SWEEP control should be set at maximum.
- 2.- An 800 microvolt signal of 5.25mc. for the adaptor is fed through a 25,000 ohm resistor to the input cable of the adaptor.
- 3.- The limiter, R110, which is marked I.F. PAD, is adjusted so that a deflection of at least one inch is attained at the center of the screen.

Under certain conditions (6SG7 tubes with extra high transconductance) I.F. regeneration or oscillation may take place. This condition may be remedied by reducing the "I.F. PAD" (counter-clockwise). The reserve I.F. gain present in the equipment may be employed as the tubes weaken in use.

11.06 Possible Operation Failures and Their Location

<u>Failure</u>	<u>Look for the Following:</u>
Set inoperative	Check fuse and all DC and AC voltages in accordance with Par. 12, Table of Tube Socket Voltages
Horizontal line fails to appear on screen	Check tubes V108 and V111 (6SL7GT) and their associated circuits
Vertical deflection fails to appear on the screen	Check all Video, I. F. and R. F. circuits by working back from the vertical plate of the C.R.T. to the input cable of the panoramic adaptor.
With the SWEEP control set at maximum, the vertical deflection (representing a signal) does not appear as a peak, but rather as a shift in the baseline.	a.- The reactor tube is not affecting frequency modulation of the F.M. oscillator. b.- Check tube V107 (6AC7) and its associated circuit.
When GAIN control is rotated frequency shift takes place	Check V106 (VR105) and R117.

12. - Table of Tube Socket Voltages

Readings taken with Voltmeter (5000 ohms per volt)
 GAIN and SWEEP controls set at max; FOCUS, INTENSITY, HOR. SIZE, POSITION controls set for normal operation.
 All readings taken from indicated pin to ground (chassis).
 Voltage readings will vary according to the type meter used.
 All voltages are D.C. unless otherwise marked.

Circuit Tube Symbol Type	Function	Pin No.													
		1	2	3	4	5	6	7	8	9	10	11	12	13	14
V101	6AC7 1st R. F. amp.	---	---	---	---	2.2	150	6.3AC	100						
V102	6SA7 F.M. osc. and 1st det.	---	---	290	105	---	---	6.3AC	---						
V103	6SG7 1st I.F. amp.	---	---	1	---	1	(a)	6.3AC	280						
V104	6SQ7 2nd det. and video amp.	---	---	---	---	-0.2	100	6.3AC	---						
V105	2X2 High volt. rect.	820AC	---	---	820AC	(Read at Plate Cap -950)	---	---	---						
V106	VR105-30 Voltage reg.	---	---	290	---	105	---	290	---						
V107	6AC7 Reactance mod.	---	---	---	---	(b)	105	6.3AC	280						
V108	6SL7GT Hor. Amp. & video amp.	3	155	(d)	6	170	(e)	6.3AC	---						
V110	6X5GT Low volt. rect.	---	---	295AC	---	295AC	---	6.3AC	320						
V111	6SL7GT Sawtooth gen. & horiz. amp.	(c)	170	11	-20	50	---	6.3AC	---						
V109	3BP1 Deflection Screen	1	2	3	4	5	6	7	8	9	10	11	12	13	14
		-920V.	-920V.	-950V.	N.C.	-640V.	N.C.	170 V.	170 V.	170 V.	155 V.	100 V.	N.C.	N.C.	-920V.

NOTES:

- (a) Depends upon setting of R110, I. F. PAD.
- (b) Depends upon settings of R119, REACTOR PAD, and R123, CENTER FREQ. control.
- (c) Depends upon setting of R152, HOR. SIZE potentiometer.
- (d) Depends upon setting of R124, V. POSITION control.
- (e) Depends upon setting of R128, H. POSITION control.
- (f) Depends upon setting of R143, INTENSITY control.
- (g) Depends upon setting of R141, FOCUS control.

TABLE I
PARTS LIST BY SYMBOL DESIGNATION
FOR MODEL RBW-2, TYPE CPN 55090-A PANORAMIC ADAPTOR

SYMBOL DESIG.	FUNCTION	DESCRIPTION	Refer to Schematic Diagram (last page of book)			TOLERANCE RATING OR MODIFICATION	CONTRACTOR'S DRAWING AND PART NUMBER
			M	F	R.		
			NAVY DWG. OR SPEC.	MFR. DESIG.			
A101	Support chassis; mount indicators, nameplates, etc.	Panel	A			P2-480b P2-503	
A102A A102B	Shield base sec- tion of reactor and converter.	F-M Oscillator shield.	A			P2-481c P1-482c	
A103	Cover and shield for adaptor	Cabinet	A			P3-522b P2-506a P2-486a P2-487b P3-488a P3-620b	
A104	Cover and shield chassis	Bottom Plate	A			P3-493e	
A105	Mount components	Chassis	A			P4-491g P2-483b P1-478b	
A106	Mount potentiom- eters	Pot Bracket	A			P2-476e	
A107	To mount and sup- port base of C.R.T. V109	C.R.T. clamp	Z		755-36-2-10		
A107A	Mount C.R.T. Clamp on chassis	C.R.T. clamp angle bracket	A			P1-477c	
A116A	Mount H.V. pot.	Bracket for H.V. pot. mount (5/8")	A			P1-496c	

SYMBOL DESIG.	FUNCTION	DESCRIPTION	NAVY DWG. OR SPEC.	M F R.	MFR. DESIG.	TOLERANCE RATING OR MODIFICATION	CONTRACTOR'S DRAWING AND PART NUMBER
A116B	Mount H.V. pot.	Bracket for H.V. pot. mount (1-7/8")		A			P1-497c
A119A	Mount 18 lug bake- elite resistor strip	Angle Bracket		A			P1-348d
A119B	Same as A119A	Z Angle Bracket		A			P1-349d
A122 A-D	Shock absorbing mounts for equip- ment	Shock mountings, square plate, rated 12 lbs. ea.		D	150 PH12		
A127	Cushion screen and C.R.T.	Cushion mounting, sponge rub- ber, 3" I.D.		F			P1-C-Z107
A129A	Lock Chassis and Panel to Cabinet	Panel Locking Screws		A			P1-495a
A129B	Lock Chassis and Panel to Cabinet	Panel Locking Studs		A			P1-494
A131	To shield scope screen from direct overhead light	Scope Hood		A			P1-312a
A146	Maintains setting of Reactor Pad	Shaft Lock		A			P1-469b P1-470b
A149	To shield C.R.T. against external magnetic fields	C.R.T. magnetic shield		A			P2-826a

NOTE:- Capacitors meet Bu. Ship's specs. #RE-13A-488D.

C101 A-C	R.F. bypass (V101)	Capacitor, 3x.1 mfd., fixed paper, metal case (same as C102, C103, C105, C107)	#48709A	B	6BAB111	+20%, 600WV	P1-E-Z116a
C102 A-C	R.F. bypass: A-2nd Anode (V109) B-Heater (V102) C-V102 thru T102 secondary	Capacitor, same as C101 A-C.					

SYMBOL DESIG.	FUNCTION	DESCRIPTION	NAVY DWG. OR SPEC.	M F R.	MFR. DESIG.	TOLERANCE RATING OR MODIFICATION	CONTRACTOR'S DRAWING AND PART NUMBER
C103 A-C	R.F. bypass (V102) (V107)	Capacitor, same as C101 A-C.		-	-	-	
C104	R.F. bypass cathode (V103)	Capacitor, 250 mmfd., fixed mica (same as C106)		C	1468	±10%, 500V	
C105 A-C	R.F. bypass (V103)	Capacitor, same as C101		-	-	-	
C106	Diode Load (V104) bypass	Capacitor, same as C104		-	-	-	
C107 A-C	Line Filter Saw. Gen. (V111)	Capacitor, same as C101 A-C		-	-	-	
C108 A-B	H.V. Filter	Capacitor, 2x.25 mfd. Fixed paper, metal case		B	20 SAL 50	±15%, 2000V	
C109	R.F. bypass (V107)	Capacitor, 100 mmfd., fixed mica		C	1468	±10%, 500V	
C110	L.V. Filter	Capacitor, 4 mfd., fixed paper, metal case (same as C111, C112)		B	6SAL 400	±10%, 600V	
C111	Same as C110	Capacitor, same as C110		-	-	-	
C112	Same as C110	Capacitor, same as C110		-	-	-	
C113	Sawtooth Grid, V111	Capacitor, .01 mfd. fixed mica		C	1467	±10%, 300V	
C114	Sawtooth Coupling	Capacitor, .25 mfd. fixed paper, top mtg., metal case		B	6BAT25	±10%, 600V	
C115	Sweep Coupling	Capacitor, .25 mfd., fixed paper, bottom mtg., metal case.		B	6BAB25	±10%, 600V	P1-E-Z117a
E101A	To adjust Center Freq. pot.	Knob, black bakelite, 1/2" dia., Allen head set screws		M			
E101 B-C	To adjust Sweep and Gain pots.	Knobs, black bakelite, curved, octagonal shape, 1-1/8" dia., 5/8" deep, Allen-head set screws.		M			
E102	Hold I101	Pilot light assembly, for bayonet type pilot light.		N	BV805		

SYMBOL DESIG.	FUNCTION	DESCRIPTION	NAVY DWG. OR SPEC.			M F R.	MFR. DESIG.	TOLERANCE RATING OR MODIFICATION	CONTRACTOR'S DRAWING AND PART NUMBER
			M	F	R.				
E103	Hold fuse F101	Fuse holder, moulded bakelite bayonet type knob.	U			HKM			
E104	Mount spare fuse and tuning rod	Dual fuse holder, fiber	0					PI-230b	
E107	Mount 10W res.	Terminal strip, mycalex, 1/8" thick, 1-7/8" long x 1-1/4" wide	A				Required for "Brown Devil" only	PI-M-I104d	
E108	Mount insulate H.V. pots.	H.V. potentiometer mount, 1/8" thick mycalex, 2-5/8" long x 1-7/8" wide.	A					PI-M-I106e	
E109	Mount resistors and condensers for wiring	Terminal strip, XX bakelite, 32 terminal lugs	A					PI-304b Type B	
E110	Insulate and mount resistors and condensers	Terminal strip, mycalex, 1/8" thick, 10 round terminal lugs	A					PI-303a	
E111A	Mount resistors and condensers for wiring	Terminal strip, XX bakelite, 18 terminal lugs.	A					PI-305b Type B	
E111B	Same as E111A	Same as E111A	-					-	
E117	Mount sub-assembly resistor and condenser for wiring	Terminal strip, XX bakelite, 1 lug.	A					PI-713 Type B	
E120	Insulate chassis and permit ease of sliding chassis into cabinet	Chassis slide strip, bakelite	A					P2-M-I101a	
E123	Contact plate of V107	Plate cap, plastic.	E				91-T-INL WRB-165		
E124	Insulate chassis and mount chassis to cabinet.	Anchor plate, bakelite.	A					PI-M-I118b	

SYMBOL DESIG.	FUNCTION	DESCRIPTION	NAVY DWG. OR SPEC.	M F R.	MFR. DESIG.	TOLERANCE RATING OR MODIFICATION	CONTRACTOR'S DRAWING AND PART NUMBER
E139	V105 Clamp	Tube clamp-Top piece, bakelite, and accessories.		R			P1-168
E142	Clamp V101, V102, V103, V107	Metal tube clamps		V	#52329		
E143	Clamp V104, V108, V110, V111	Glass tube clamps		W	#8599		
E144	V106 Clamp	Tube clamp for VR105		W	#8548		
E145	To align coils and adjust slotted pots.	Aligning tool, bakelite		A			P1-170a
E146	To fit Allen-head screws on knobs	Allen wrench		M	#8		
E146A	Mount wrench to chassis	Allen wrench clip		T	#45		
F101	Prevent damage from overload	Fuse, 2A, 250V, non-renewable.		O	#3AG/2A		
I101	On-off Indicator	Lamp, pilot light, bayonet base, 6/8V, 150 MA.		P	#47		
I126	Calibration Screen	Lumarith green screen, filter		A	Green #04650 .125		P1-M-1122e
J101	Connect R-F input to signal input	Receptacle, single coaxial.	CPH 49194	K	83-1R		
J102	Connect power from power line to chassis	Receptacle, moulded phenolic twist type, 3 pole, flush male base, 10A, 250V.		L	7484		
L101A-B	Filter Choke	Choke, filter, double, each section: 6.5H measured at 40 MA. DC., 5V, 60 cycle.		A			P1-555b

SYMBOL DESIG.	FUNCTION	DESCRIPTION	NAVY DWG. OR SPEC.		M F R.	MFR. DESIG.	TOLERANCE RATING OR MODIFICATION	CONTRACTOR'S DRAWING AND PART NUMBER
P101	Connect R-F input to chassis connector	Plug, 1 pole, male, H.F. input, cable coupling to plug, polystyrene insulation (same as P201)	CPH 49195		K	83-1SP		
P101A	Same as P101	R.F. Input Angle Plug.	CPH 49192		K	83-1AP		
P102	Connect power from power line to chassis connector	Plug, moulded phenolic twist type, 3 pole, female, 10A, 250V, cord grip			L	7486		
P103	Power line plug	Plug, 2 pole, male, 10A, 250V			Q			
R101	Gain Control (V101)	Potentiometer, carbon, 10,000 ohms, 1W, right hand taper, screwdriver slot.			H	V37	+20%	
R102	Grid bias, (V101)	Resistor, fixed carbon, 150 ohms, ceramic insulated, 1/2W. (Same as R109)			G	504	+10%	
R103	Screen bleeder (V101)	Resistor, fixed carbon, 50,000 ohms, ceramic insulated, 1W (same as R104, R105, R111, R112)			G	518	+10%	
R104	Screen bleeder (V101)	Resistor, same as R103			-	-	-	
R105	Screen bleeder (V101)	Resistor, same as R103			-	-	-	
R106	Plate isolation (V101)	Resistor, fixed carbon, 2,000 ohms, ceramic insulated, 1W (Same as R108)			G	518	+10%	
R107	Omitted	Omitted.						
R108	Plate isolation (V102)	Resistor, same as R106			-	-	-	
R109	Grid bias (V103)	Resistor, same as R102			-	-	-	

SYMBOL DESIG.	FUNCTION	DESCRIPTION	NAVY DWG. OR SPEC.		M	MFR. DESIG.		TOLERANCE RATING OR MODIFICATION	CONTRACTOR'S DRAWING AND PART NUMBER
						F	R.		
R110	I.F. pad (V103)	Potentiometer, carbon, 100,000 ohms, 1W, linear taper, screw-driver slot.			H		W37	+20%	
R111	Screen dropping resistor (V103)	Resistor, same as R103			-		-	-	
R112	Screen dropping resistor (V103)	Resistor, same as R103			-		-	-	
R113	Plate Isolation, (V103)	Resistor, fixed carbon, 5,000 ohms, 1W, ceramic insulated			G		518	+10%	
R114	Diode Load, bias (V104)	Resistor, fixed carbon, 150,000 ohms, 1/2W, ceramic insulated			G		504	+10%	
R115	Plate Limiting Resistor, (V104)	Resistor, fixed carbon, 750,000 ohm, 1/2W, ceramic insulated			G		504	+10%	
R116	H.V. Filter	Resistor, fixed carbon, 25,000 ohm, 1W, ceramic insulated			G		518	+10%	
R117	Regulator Dropping Resistor (V106)	Resistor, fixed, Wire Wound, 7500 ohm, 10W, cement coated and insulated			AA or I		DH or Brown Devil	+10%	P1-175
R118	Grid Return (V107)	Resistor, fixed carbon 200,000 ohm, 1/2W, ceramic insulated (same as R138)			G		504	+10%	
R119	Reactor Pad	Potentiometer, Carbon, 1,000 ohm, 1W, linear taper, screw-driver slot			H		W37	+20%	
R120	Sweep Pad	Potentiometer, Carbon, 250,000 ohm, 1W, linear taper, screw-driver slot (same as R141)			H		W37	+20%	
R121	Center Freq. net	Resistor, fixed carbon, 500 ohm, 1/2W, ceramic insulated (same as R144)			G		504	+10%	

SYMBOL DESIG.	FUNCTION	DESCRIPTION	NAVY DWG. OR SPEC.	M F R.	MFR. DESIG.	TOLERANCE RATING OR MODIFICATION	CONTRACTOR'S DRAWING AND PART NUMBER
R122	Center Freq. net	Resistor, fixed carbon, 200 ohm, 1/2W, ceramic insulated (same as R145)		G	504	±10%	
R123	Center Freq. ADJ	Potentiometer, carbon, 500 ohm, 1W, linear taper, screwdriver slot.		H	W37	-10%, +20%	
R124	Vertical position	Potentiometer, carbon, 500,000 ohm, 1W, linear taper, screw-driver slot (same as R128)		H	W37	±20%	
R125	Bias Net, (V108 B)	Resistor, fixed carbon, 150,000 ohm, 1W, ceramic insulated Same as R126, R129, R136, R142)		G	518	±10%	
R126	Plate Load (V108 B)	Resistor, same as R125		-	-	-	
R127	Plate Load (V108 A)	Resistor, fixed carbon, 250,000 ohm, 1W, ceramic insulated. (Same as R151)		G	518	±10%	
R128	Horizontal position	Potentiometer, same as R124		-	-	-	
R129	Bias Net (V108A)	Resistor, same as R125		-	-	-	
R130	Grid Return (V108A)	Resistor, fixed, carbon, 100,000 ohm, 1/2W, ceramic insulated (same as R137)		G	504	±10%	
R131	Bias (V108A)	Resistor, fixed, carbon, 5,000 ohm, 1/2W, ceramic insulated (same as R148)		G	504	±10%	
R132	Bias (V108B)	Resistor, fixed, carbon, 2,500 ohm, 1/2W, ceramic insulated		G	504	±10%	
R133	Coupling (V108A)	Resistor, fixed, carbon, 2 megohm, 1/2W, ceramic insulated (Same as R134)		G	504	±10%	
R134	Coupling (108B)	Resistor, same as R133		-	-	-	

SYMBOL DESIG.	FUNCTION	DESCRIPTION	NAVY DWG. OR SPEC.	MFR. DESIG.		TOLERANCE RATING OR MODIFICATION	CONTRACTOR'S DRAWING AND PART NUMBER
				M	F		
R135	Grid Return (V108B)	Resistor, fixed, carbon, 75,000 ohm, 1/2W, ceramic insulated		G	504	±10%	
R136	Plate Load (V104)	Resistor, same as R125		-	-	-	
R137	2nd Anode Net (V109)	Resistor, same as R130		-	-	-	
R138	2nd Anode Net (V109)	Resistor, same as R118		-	-	-	
R139	Bias (V102)	Resistor, fixed, carbon, 1,000 ohm, 1/2W, ceramic insulated		G	504	±10%	
R140	H.V. bleeder	Resistor, fixed, carbon, 500,000 ohm, 1W, ceramic insulated		G	518	±10%	
R141	Focus Control	Potentiometer, same as R120		-	-	-	
R142	H.V. bleeder	Resistor, same as R125		-	-	-	
R143	Intensity control	Potentiometer, carbon, 50,000 ohm, 1W, linear taper, screw-driver slot		H	W37	±20%	
R144	Synch. Net	Resistor, same as R121.		-	-	-	
R145	Synch. Net	Resistor, same as R122.		-	-	-	
R146	Grid Resistor (V111A)	Resistor, fixed, carbon, 500,000 ohm, 1/2W, ceramic insulated		G	504	±10%	
R147	Synch. Control	Potentiometer, carbon, 1 megohm, 1W, linear taper, screwdriver slot (same as R153)		H	W37	±20%	
R148	Bias (V111B)	Resistor, same as R131		-	-	--	
R149	Sweep Net	Resistor, fixed, carbon, 25,000 ohm, 1/2W, ceramic insulated (same as R201)		G	504	±10%	

SYMBOL DESIG.	FUNCTION	DESCRIPTION	NAVY DWG. OR SPEC.		M F R.	MFR. DESIG.	TOLERANCE RATING OR MODIFICATION	CONTRACTOR'S DRAWING AND PART NUMBER
R150	Sawtooth generator (V111A)	Resistor, fixed, carbon, 3 megohm, 1/2W, ceramic insul- ated	G	504			+10%	
R151	Plate Load (V111B)	Resistor, same as R127	-	-			-	
R152	Horizontal size control	Potentiometer, carbon, 2 megohm, 1W, linear taper, screwdriver slot	H	W37			+20%	
R153	Sweep Limiter	Potentiometer, same as R147	-	-			-	
R201	Decoupling Resistor	Resistor, same as R149	-	-			-	
S101	Switch power on and off	Switch, toggle single pole, single throw, 3A, 250V, laminated bakelite	Y	#24000				
T101-02	Couple input to RF amp. V101	Trans. bandpass input, permeabil- ity tuned. Frequency is 5.25 MC±500KC	A					P2-793a P2-767
C1	Blocking cap.	Capacitor, fixed, 100 mmfd.	C				+10%	
C2	Primary tank cap.	Capacitor, fixed, 20 mmfd.	C				+10%	
C3	Secondary tank cap.	Capacitor, fixed, 15 mmfd.	C				+10%	
R5	Loading resistor	Resistor, fixed, carbon 100,000 ohms, ceramic insulated 1/2W.	G	504			+10%	
R6	Loading resistor	Resistor, fixed, carbon 300,000 ohms, ceramic insulated 1/2W.	G	504			+10%	
T102-02	Coupling first R-F amp. V101 to conv. V102	Trans. bandpass interstage, per- meability tuned. Frequency is 5.25 MC±500KC.	A					P2-794a P2-767
C4	Primary tank cap.	Capacitor, fixed, 10 mmfd.	C				+10%	
C5	Secondary tank cap.	Capacitor, same as C4	C				+10%	
C6	Coupling cap.	Capacitor, fixed, 1000 mmfd.	C				+10%	
R7	Loading resistor	Resistor, fixed, carbon 300,000 ohms, ceramic insulated 1/2W.	G	504			+10%	

SYMBOL DESIG.	FUNCTION	DESCRIPTION	NAVY DWG. OR SPEC.	M F R.	MFR. DESIG.	TOLERANCE RATING OR MODIFICATION	CONTRACTOR'S DRAWING AND PART NUMBER
T103	Blocking tube osc. trans. (sawtooth gen.)	Transformer, Blocking Tube Os- cillator, 2:1 ratio secondary to primary.		A			P1-554b
T104	Supply all L.V. and H.V. operating potentials	Transformer, power primary 110V, 115V, 120W, 25-60 cycles, 5 secondary windings 995V tapped 295V at 60 ma and at 295V, rat- ing from first tap to end of winding is 700V at 1 ma; 2.5V at 2 a.; 6.3V at 3 a.; 6.3V at 6a; tapped 2.5V at 2.5 a.; 6.3V at .6a.					P2-744a
V101	1st R.F. Amplifier	6AC7/1852 (Same as V107)	JAN-1A	J	6AC7		
V102	Oscillator Mixer	6SA7	JAN-1A	J	6SA7		
V103	1st I.F. Amplifier	6SG7	JAN-1A	J	6SG7		
V104	2nd Detector, Video Amplifier	6SQ7	JAN-1A	J	6SQ7		
V105	C.R.T. Power Sup- ply Rectifier	2X2	JAN-1A	J	2X2		
V106	Voltage Regulator	VR105/30	JAN-1A	J	VR105/30		
V107	Reactance Modulator	(Same as V101)	-	-	-		
V108	Video Amplifier, Horizontal Amplifier	6SL7/GT (Same as V111)	JAN-1A	J	6SL7GT		
V109	Cathode Ray Tube	3BP1	JAN-1A	J	3BP1		
V110	Low Voltage Power Supply	6X5GT	JAN-1A	J	6X5		
V111	B.T.O., Horizontal Amplifier	(Same as V108)	-	-	-		

CONTRACTOR'S
DRAWING AND
PART NUMBER

TOLERANCE
RATING OR
MODIFICATION

M F MFR.
R. DESIG.

NAVY DWG.
OR SPEC.

DESCRIPTION

FUNCTION

SYMBOL
DESIG.

SYMBOL DESIG.	FUNCTION	DESCRIPTION	NAVY DWG. OR SPEC.	M F MFR. R. DESIG.	TOLERANCE RATING OR MODIFICATION	CONTRACTOR'S DRAWING AND PART NUMBER
W103	R-F input cable	Cord, low-loss, single conductor H.F. copolene, 3# terminating in plugs at each end	RE-13A-639C K RG-11/U	21B-290- 16CW-XV		
X101	Mount V101	Socket, octal, mica filled or ceramic. (Same as X102, X103, X104, X106, X107, X108, X110, X111)		R KS 10067		
X102	Mount V102	Socket, same as X101		-		
X103	Mount V103	Socket, same as X101		-		
X104	Mount V104	Socket, same as X101		-		
X105	Mount V105	Socket, 4-prong, ceramic wafer.		X 224N		
X106	Mount V106	Socket, same as X101		-		
X107	Mount V107	Socket, same as X101		-		
X108	Mount V108	Socket, same as X101		-		
X109	Mount V109	Socket, 14 prong, molded bakelite		R #40-1, #40-3		
X110	Mount V110	Socket, same as X101		-		
X111	Mount V111	Socket, same as X101		-		
Z101-02	F.M. Oscillator coil, Reactance Modulator Coil, and Resistor Capacitor Phasing Network	Coil, oscillator composite, including oscillator coil and H.F. choke; permeability tuned. Frequency is 6.162 MC±500KC.		A		P2-795b P2-798e
C12	Coupling cap.	Capacitor, fixed, 50 mmfd.		C	±10%	
C13	Tank tuning cap.	Capacitor, fixed, 10 mmfd.		C	±10%	
C14	Phase net cap.	Capacitor, fixed, 5 mmfd.		C	±10%	
C15	Phase net cap.	Capacitor, same as C14		C	±10%	

SYMBOL DESIG.	FUNCTION	DESCRIPTION	NAVY DWG. OR SPEC.	M F R.	MFR. DESIG.	TOLERANCE RATING OR MODIFICATION	CONTRACTOR'S DRAWING AND PART NUMBER
Z101-02 (Cont.)							
C16	Blocking cap.	Capacitor, fixed, 100 mmfd.		C		±10%	
C17	Blocking cap.	Capacitor, fixed, 500 mmfd.		C		±10%	
R1	Damping Load	Resistor, fixed, carbon, 3,000 ohms, ceramic insulated 1/2W.		G	504	±10%	
R2	Phase Net	Resistor, same as R1		G	504	±10%	
R3	Grid bias.	Resistor, fixed, carbon, 50,000 ohms, ceramic insulated 1/2W.		G	504	±10%	
R4	Phase Net	Resistor same as R1		G	504	±10%	
Z102-02							
	I.F. Input Trans.	Trans., I-F input, permeability tuned. Frequency is 912KC.		A			P2-796a P2-746a
C8	Primary tank cap.	Capacitor, fixed, 80 mmfd.		C		±10%	
C9	Secondary tank cap.	Capacitor, fixed, same as C8		C		±10%	
Z103-02							
	I.F. Output Trans.	Trans., I-F output, permeability tuned. Frequency is 912KC.		A			P2-797a P2-746a
C10	Primary tank cap.	Capacitor, fixed, 80 mmfd.		C		±10%	
C11	Secondary tank cap.	Capacitor, fixed, 100 mmfd.		C		±10%	

KEY TO MANUFACTURERS (Refer to Table I)

- A Panoramic Radio Corp., 242 W. 55th St., N.Y.C.
- B Industrial Condenser Corp., Chicago, Ill.
- C Aerovox Corp., New Bedford, Mass.
- D Lord Mfg. Co., Erie, Pa.
- E Alden Products Co., Brockton, Mass.
- F Harry Goldman, 230 W. 58th St., N.Y.C.
- G Erie Resistor Co., Erie, Pa.
- H Clarostat Mfg. Co., Brooklyn, N. Y.
- I Ohmite Mfg. Co., Chicago, Ill.
- J R.C.A. Manufacturing Co., Camden, N.J.
- K American Phenolic Corp., Chicago, Ill.
- L Harvey Hubbell, Bridgeport, Conn.
- M Kirz-Kasch Co., Dayton, Ohio
- N Dialight Corp. of America, New York, N.Y.
- O Littlefuse, Inc., Chicago, Ill.
- P General Electric Corp., Schenectady, N.Y.
- Q Eagle Electric Co., Brooklyn, N.Y.
- R A.W. Franklin Co., New York, N.Y.
- S National Co., Malden, Mass.
- T Fahnestock Electric Co., Long Island City, N.Y.
- U Bussman Mfg. Co., St. Louis, Mo.
- V United Carr Fastener, Cambridge, Mass.
- W Cinch Mfg. Corp., Chicago, Ill.
- X E. F. Johnson Co., Waseca, Minn.
- Y Hart & Hegeman, Bridgeport, Conn.
- Z Huntington Precision Products, Huntington, W. Va.
- AA International Resistance Corp., Philadelphia, Pa.

TABLE II
LIST OF SPARES

MODEL RBW-2, TYPE CPN 55090-A

MANUFACTURER: PANORAMIC RADIO CORP.
NEW YORK, N.Y.

SYMBOL DESIGNATION	NAME OF PART	QUANT. IN EQUIP.	QUANT. PER EQUIP. SPARES	QUANT. PER TENDER SPARES	QUANT. PER STOCK SPARES
A122 A-D	Shock Mounts	4	1/4	4/4	8/4
A127	C.R.T. Boot, rubber	1	1/1	2/1	4/1
A129A	Panel Locking Screws	8	0/8	0/8	8/8
A129B	Panel Locking Studs	8	0/8	0/8	8/8
A146	Shaft Lock	1	0/1	0/1	1/1
C101 A-C C102 A-C C103 A-C C105 A-C C107 A-C	Capacitor, 3x.1 mfd., 600V, bathtub	5	3/5	8/5	13/5
C104 C106	Capacitor, 250 mmfd., 500V, mica	2	1/2	1/2	1/2
C108 A-B	Capacitor, 2x.25 mfd., 2000V, metal case	1	1/1	2/1	3/1
C109	Capacitor, 100 mmfd., 500 V, mica	1	1/1	1/1	1/1
C110 C111 C112	Capacitor, 4 mfd., 600 V, metal case	3	2/3	5/3	8/3
C113	Capacitor, .01 mfd., 300 V, mica	1	2/1	2/1	2/1
C114	Capacitor, .25 mfd., 600V, bathtub, top mounting	1	1/1	2/1	3/1
C115	Capacitor, .25 mfd., 600V, bathtub, bottom mounting	1	1/1	2/1	3/1
E102	Pilot Light Assembly	1	1/1	1/1	1/1
E103	Fuse Holder, extractor, post type	1	1/1	1/1	1/1
E104	Dual Fuse Holder	1	1/1	1/1	1/1
E123	Plate Cap, phenolic	1	0/1	0/1	1/1
E139	Tube Clamp for 2X2	1	1/1	1/1	1/1
E142	Tube Clamp, Metal	5	2/5	2/5	3/5
E143	Tube Clamp, Glass	3	1/3	1/3	2/3
E144	Tube Clamp, VR-105	1	1/1	1/1	1/1
E145	Aligning Tool, Bakelite	1	1/1	1/1	2/1

SYMBOL DESIGNATION	NAME OF PART	QUANT. IN EQUIP.	QUANT. PER EQUIP. SPARES	QUANT. PER TENDER SPARES	QUANT. PER STOCK SPARES
E146	Allen Head Wrench, #8	1	1/1	1/1	2/1
F101	Fuse, 250V, 2 a.	1	10/1	20/1	50/1
I101	Pilot Lamp, 6-8V, .15 a.	1	2/1	4/1	6/1
J101	R.F. Input, Receptacle, #49194	1	1/1	1/1	2/1
None	R.F. Cable, complete with plug	1	1/1	1/1	2/1
J102	A.C. Plug, 250V, 10a., 3 Wire Midget #7484	1	1/1	1/1	2/1
L101 A-B	Dual Choke	1	1/1	2/1	3/1
P101	R.F. Input Plug, #49195	1	1/1	1/1	2/1
P101 A	R.F. Input Angle Plug, #49192	1	1/1	1/1	2/1
P102	A.C. Receptacle, 10 a., 250V, 3 Wire Midget, #7486	1	1/1	1/1	2/1
	RESISTORS, FIXED CARBON, 1/2 W.				
R102	150 ohms	2	2/2	6/2	10/2
R109					
R114	150,000 ohms	1	1/1	3/1	5/1
R115	750,000 ohms	1	1/1	3/1	5/1
R118	200,000 ohms	2	2/2	6/2	10/2
R138					
R121	500 ohms	2	2/2	6/2	10/2
R144					
R122	200 ohms	2	2/2		10/2
R145					
R130	100,000 ohms	2	2/2	6/2	10/2
R137					
R131	5,000 ohms	2	2/2	6/2	10/2
R148					
R132	2,500 ohms	1	1/1	3/1	5/1
R133	2 megohms	2	2/2	6/2	10/2
R134					
R135	75,000 ohms	1	1/1	3/1	5/1
R139	1,000 ohms	1	1/1	3/1	5/1
R146	500,000 ohms	1	1/1	3/1	5/1
R149	25,000 ohms	2	2/2	6/2	10/2
R201					
R150	3 megohms	1	1/1	3/1	5/1

SYMBOL DESIGNATION	NAME OF PART	QUANT. IN EQUIP.	QUANT. PER EQUIP. SPARES	QUANT. PER TENDER SPARES	QUANT. PER STOCK SPARES
RESISTORS, FIXED, CARBON, 1 W.					
R103	50,000 ohms	5	5/5	15/5	25/5
R104					
R105					
R111					
R112					
R106	2,000 ohms	2	2/2	6/2	10/2
R108					
R113	5,000 ohms	1	1/1	3/1	5/1
R116	25,000 ohms	1	1/1	3/1	5/1
R125	150,000 ohms	5	5/5	15/5	25/5
R126					
R129					
R136					
R142					
R127	250,000 ohms	2	2/2	6/2	10/2
R151					
R140	500,000 ohms	1	1/1	3/1	5/1
RESISTOR, FIXED, WIREWOUND, 10 W					
R117	7,500 ohms	1	1/1	3/1	5/1
POTENTIOMETERS, CARBON					
R101	10,000 ohms, right hand taper	1	1/1	3/1	5/1
R110	100,000 ohms, linear taper	1	1/1	3/1	5/1
R119	1,000 ohms, linear taper	1	1/1	3/1	5/1
R120	250,000 ohms, linear taper	2	2/2	6/2	10/2
R141					
R123	500 ohms, linear taper	1	1/1	3/1	5/1
R124	500,000 ohms, linear taper	2	2/2	6/2	10/2
R128					
R143	50,000 ohms, linear taper	1	1/1	3/1	5/1
R147	1 megohm, linear taper	2	2/2	6/2	10/2
R153					
R152	2 megohms, linear taper	1	1/1	3/1	5/1
S101	Toggle Switch, S.P.S.T.	1	1/1	1/1	1/1
T101 - 02	Bandpass Input Transformer	1	1/1	2/1	3/1
T102 - 02	Bandpass Output Transformer	1	1/1	2/1	3/1

SYMBOL DESIGNATION	NAME OF PART	QUANT. IN EQUIP.	QUANT. PER EQUIP. SPARES	QUANT. PER TENDER SPARES	QUANT. PER STOCK SPARES
T103	B.T.O. Transformer	1	1/1	2/1	3/1
T104	Power Transformer	1	1/1	2/1	3/1
V101 V107	Tube, 6AC7	2	4/2	6/2	0/2
V102	Tube, 6SA7	1	2/1	3/1	0/1
V103	Tube, 6SG7	1	2/1	3/1	0/1
V104	Tube, 6SQ7	1	2/1	3/1	0/1
V105	Tube, 2X2	1	2/1	3/1	0/1
V106	Tube, VR105/30	1	2/1	3/1	0/1
V108 V111	Tube, 6SL7GT	2	4/2	6/2	0/2
V109	Tube, 3BP1	1	3/1	6/1	0/1
V110	Tube, 6X5GT	1	2/1	3/1	0/1
X101 X102 X103 X104 X106 X107 X108 X110 X111	Sockets, Octal, Ceramic	9	5/9	5/9	9/9
X105	Socket, 4 Prong, Ceramic	1	1/1	1/1	1/1
X109	Sockets, diheptal, bakelite	1	1/1	1/1	1/1
Z101 - 02	Oscillator Composite Coil	1	1/1	2/1	3/1
Z102 - 02	I.F. Input Coil	1	1/1	2/1	3/1
Z103 - 02	I.F. Output Coil	1	1/1	2/1	3/1

TABLE III
Color Code Charts

CAPACITY MARKING: Invariably, capacity is expressed (for coding purposes) in terms of micromicrofarads, as .00025 = 250 mmf.

The colors employed to designate these significant digits in mmf. are listed below. Note that codes are read from left to right in the position required for reading of words molded in case, or by arrow.

Color	Numeral	Volts	Multiplier	Tolerance
Black	0		1	
Brown	1	100	10	1%
Red	2	200	100	2%
Orange	3	300	1,000	3%
Yellow	4	400	10,000	4%
Green	5	500	100,000	5%
Blue	6	600	1,000,000	6%
Violet	7	700	10,000,000	7%
Gray	8	800	100,000,000	8%
White	9	900	1,000,000,000	9%
Gold		1000	.1	
Silver			.01	10%
No Color		500		20%

3-DOT COLOR CODE: This is used to indicate capacity (in mmf.) where the working voltage is 500 v.d.c. and the tolerance is $\pm 20\%$.

1. The first dot indicates the first significant digit of capacity.
2. The second dot indicates the second digit of capacity.
3. The third dot indicates the number of zeros which follow after the first two digits.

EXAMPLE:

Red Green Black = 25 mmf. = .000025 mfd.

6-DOT R. M. A. COLOR CODE: When it is essential to indicate three significant figures of capacity (such as 1250 mmf.), together with voltage and tolerance information, it is desirable to employ the 6-Dot Code.

On units marked with six dots, the upper three dots are significant figures of capacity in mmf. multiplied by the multiplier indicated by the lower right hand dot. The remaining dots are tolerance and D.C. working voltage rating, as shown in sketch.

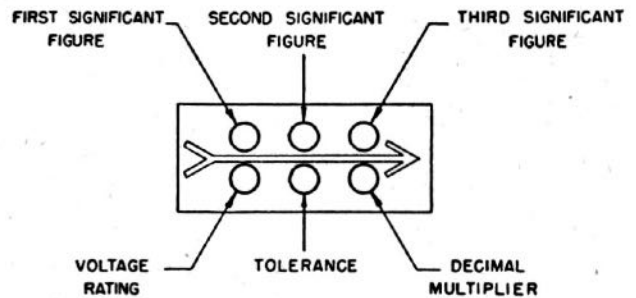

EXAMPLE:

Brown Red Green } = 1250 mmf.,
Orange Green Brown } 300 v.d.c.w. $\pm 5\%$

SILVER MICA IDENTIFICATION: Silver mica capacitors are molded in distinctive Red Low-loss Bakelite, precluding any possibility of confusion.

R. M. A. COLOR CODE FOR RESISTORS

Color	Body	End	Dot
Black	--	0	0
Brown	1	1	0
Red	2	2	00
Orange	3	3	000
Yellow	4	4	0000
Green	5	5	00000
Blue	6	6	000000
Purple	7	7	0000000
Gray	8	8	00000000
White	9	9	-----

Body color denotes first numeral in resistance value.

End color denotes second numeral.

Dot color denotes number of ciphers following first two numerals.

Gold color bronze end dip indicates 20% tolerance.

Silver color bronze end dip indicates 5% tolerance.

Other resistors 10% tolerance.

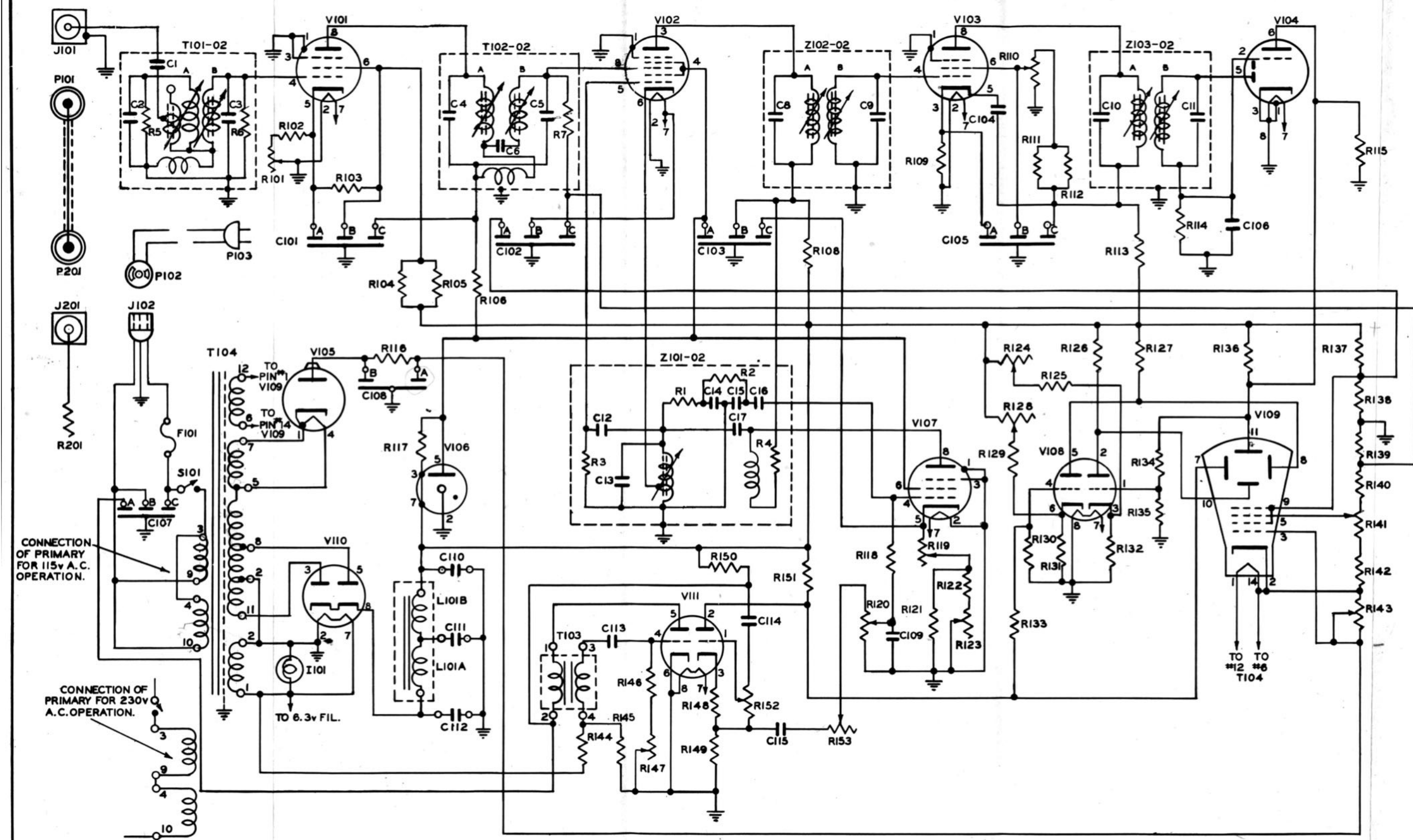

			C102AC	R.F. BYPASS-V102, V109	3X.1MFD. 600V.
			C101AC	R.F. BYPASS-V101	3X.1MFD. 600V.
			R201	DECOUPLING RESISTOR	25,000 OHMS 1/2W.
			R153	SWEEP LIMITER	1 MEGOHM POT.
			R152	HOR. SIZE CONTROL	2 MEGOHM POT.
			R151	PLATE LOAD - VIII B	250,000 OHMS 1W
			R150	SAW. GENERATOR - VIII A	3 MEGOHMS 1/2W.
			R149	SWEEP NET	25,000 OHMS 1/2W.
			R148	BIAS-VIII B	5,000 OHMS 1/2W.
			R147	SYNCH. CONTROL	1 MEGOHM POT.
			R146	GRID RESISTOR-VIII A	500,000 OHMS 1/2W.
			R145	SAME AS R144	200 OHMS 1/2W.
			R144	SYNCH. NET	500 OHMS 1/2W.
			R143	INTENSITY CONTROL	50,000 OHMS POT.
			R142	H.V. BLEED	150,000 OHMS 1W.
			R141	FOCUS CONTROL	250,000 OHMS POT.
			R140	H.V. BLEED	500,000 OHMS 1W.
			R139	BIAS-V102	1,000 OHMS 1/2W.
			R138	SAME AS R137	200,000 OHMS 1/2W.
			R137	2ND ANODE NET-V109	100,000 OHMS 1/2W.
			R136	PLATE LOAD-V104	150,000 OHMS 1W.
			R135	GRID RETURN-V108B	75,000 OHMS 1/2W.
			R134	COUPLING-V108B	2 MEGOHMS 1/2W.
			R133	COUPLING-V108A	2 MEGOHMS 1/2W.
			R132	BIAS-V108B	2,500 OHMS 1/2W.
			R131	BIAS-V108A	5,000 OHMS 1/2W.
			R130	GRID RETURN-V108A	100,000 OHMS 1/2W.
			R129	BIAS NET-V108A	150,000 OHMS 1W.
			R128	HOR. POSITION	500,000 OHMS POT.
			R127	PLATE LOAD-V108A	250,000 OHMS 1W.
			R126	PLATE LOAD-V108B	150,000 OHMS 1W.
			R125	BIAS NET-V108B	150,000 OHMS 1W.
			R124	VERTICAL POSITION	500,000 OHMS POT.
			R123	CENTER FREQUENCY ADJ.	500 OHMS POT.
			R122	SAME AS R121	200 OHMS 1/2W.
			R121	CENTER FREQUENCY NET	500 OHMS 1/2W.
			R120	SWEEP	250,000 OHMS POT.
			R119	REACTOR PAD	1,000 OHMS POT.
			R118	GRID RETURN-V107	200,000 OHMS 1/2W.
			R117	REGULATOR DROP-V106	7,500 OHMS 10W.
			R116	H.V. FILTER	25,000 OHMS 1W.
			R115	PLATE LIMITING-V104	750,000 OHMS 1/2W.
			R114	DIODE LOAD, BIAS-V104	150,000 OHMS 1/2W.
			R113	PLATE ISOLATION-V103	5,000 OHMS 1W.
			R112	SAME AS R111	50,000 OHMS 1W.
			R111	SCREEN DROP-V103	50,000 OHMS 1W.
			R110	I.F. PAD-V103	100,000 OHMS POT.
			R109	GRID BIAS-V103	150 OHMS 1/2W.
			R108	PLATE ISOLATION-V102	2,000 OHMS 1W.
			R107	OMITTED	
			R106	PLATE ISOLATION-V101	2,000 OHMS 1W.
			R105	SAME AS R103	50,000 OHMS 1W.
			R104	SAME AS R103	50,000 OHMS 1W.
			R103	SCREEN BLEEDER-V101	50,000 OHMS 1W.
			R102	GRID BIAS-V101	150 OHMS 1/2W.
			R101	GAIN CONTROL	10,000 OHMS POT.
			SYM.	FUNCTION	VALUE
Z10302	I.F. OUTPUT TRANS.	912 KC.			
Z10202	I.F. INPUT TRANS.	912 KC.			
Z10102	OSC. REACTOR COMPOSITE	6.162 MC. ±.5 MC.			
VIII	SAW. GEN. & HOR. AMP.	6SL7-(GT/G)			
V110	LOW VOLT. RECTIFIER	6X5-(GT/G)			
V109	PANORAMIC INDICATOR	3BP1			
V108	HOR. & VERT. AMP.	6SL7-(GT/G)			
V107	REACTOR	6AC7			
V106	REGULATOR	VR105/30			
V105	HIGH VOLT. RECTIFIER	2X2			
V104	DETECTOR & VIDEO AMP	6SQ7-(GT/G)			
V103	I.F. AMPLIFIER	6SG7			
V102	OSCILLATOR MIXER	6SA7			
V101	R.F. INPUT AMPLIFIER	6AC7			
T104	POWER TRANSFORMER				
T103	B.T.O. TRANSFORMER				
T10202	R.F. OUTPUT TRANS.	5.25 MC. ±.5 MC.			
T10102	R.F. INPUT TRANS.	5.25 MC. ±.5 MC.			
S101	POWER SWITCH	250V. 3AMP.			
P201	OMITTED				
P103	LINE PLUG				
P102	FEMALE PLUG CONN.	250V. 10 AMP.			
P101	R.F. COAX. PLUG	NAVY NO'S CPH49192 & CPH49195			
L101AB	L.V. FILTER CHOKES	6.5HY. PER SECTION			
J102	OMITTED				
J101	RECESSED MALE CONN.	250V. 10 AMP.			
I101	PANORAMIC ADAPTOR INPUT	NAVY CPH-49194			
F101	PILOT LIGHT	6-8V. .15 AMP.			
F101	FUSE	250V. 2 AMP.			
C115	SWEEP COUPLING	.25MFD. 600V.			
C114	SAWTOOTH COUPLING	.25MFD. 600V.			
C113	SAWTOOTH GRID-VIII	.01MFD. 600V. MICA			
C112	SAME AS C110	4MFD. 600V.			
C111	SAME AS C110	4MFD. 600V.			
C110	L.V. FILTER	4MFD. 600V.			
C109	R.F. BYPASS-V107	100MMFD. 500V. MICA			
C108AB	H.V. FILTER	2X.25MFD. 2,000V.			
C107AC	LINE FILTER-SAWGEN-VIII	3X.1MFD. 600V.			
C106	DIODE LOAD-V104	250MMFD. 500V. MICA			
C105AC	R.F. BYPASS-V103	3X.1MFD. 600V.			
C104	R.F. BYPASS CATHODE-V103	250MMFD. 500V. MICA			
C103AC	R.F. BYPASS-V102, V107	3X.1MFD. 600V.			

CIRCUIT DIAGRAM-PANORAMIC ADAPTOR NAVY MODEL RBW-2 TYPE CPN-55090-A