

SHIPBOARD
ANTENNA
DETAILS

NavShips 900,121

Prepared by Mare Island Naval Shipyard

BUREAU of SHIPS • NAVY DEPARTMENT

Bureau of Ships
Navy Department
Washington, D.C.
10 May 1946

1. "Shipboard Antenna Details", NavShips 900,121, is an UNCLASSIFIED publication.
2. The material in this publication has been assembled by Mare Island Naval Shipyard from various Bureau of Ships plans, specifications, drawings, and published articles. As a result it offers under one cover a convenient reference for all activities concerned with shipboard wire type antenna installations. The publication establishes a uniform method of designating all approved rigging methods, thus providing a common "language" for use in correspondence, plans, or verbal instructions. It is requested that all activities adopt this nomenclature. Working drawings may reference NavShips 900,121 when specifying any of these standard details.
3. For maximum benefit the publication should be widely distributed to all personnel concerned with the actual work of antenna installation. To that end the booklet has been printed in pocket-size.
4. Additional copies are available on request to the Bureau of Ships.

E. L. Cochrane

E. L. Cochrane
Vice Admiral, USN
Chief of the Bureau of Ships

Foreword

Each detail in this booklet is indicated by a letter and number. The letter represents the composition of the detail, and the number indicates the size of the components. For example, *D1* and *D4* have the same composition (that is, arrangement of parts), but the size wire, insulator and fittings vary. The use of these details in a typical installation is shown on page 39.

In general, there are two sizes of wire and fittings and four sizes of insulators. Details with numbers 1 and 2 use 1/8" wire and fittings with 5" and 10" insulators respectively. Numbers 3, 4, and 5 indicate 5/16" wire and fittings with 10", 15", and 20" insulators respectively. The number 6 is used for details having both sizes of fittings.

Letters *A* to *W* inclusive apply to details with insulators. The letter *X* indicates conductor terminations, *Y* indicates junctions, and *Z* is used for miscellaneous items such as the padeye. Numbers are not used with the *X*, *Y*, and *Z* details.

General Notes

1. Paint, varnish, shellac, grease, or any other form of coating shall not be applied to any portion of ceramic insulating material forming part of the antenna system.

2. Before installation all bronze wire is to be covered with heavy petrolatum. The antenna wire shall be of one continuous length from entrance insulator to extreme end and free from kinks, sharp bends, deformed spots, and broken strands.

3. Antenna downleads shall be rigged to suspension insulators in such a manner as to preclude any strain on the conductor studs of entrance insulators. Antenna downleads, jumpers, connectors, etc. shall be sufficiently taut to prevent sway and possible contact with any object or structure.

Table of Contents

Foreword.	iii
General Notes	iv
Table of Contents	v
Detail A.	1
B.	2
C.	3
D.	4
E.	5
F.	6
G.	7
H.	8
I.	9
J.	10
K.	11
L.	12
M.	13
N.	14
O.	15
P.	16
Q.	17
R.	18
S.	19
T.	20
U.	21
V.	22
W.	23
X.	24
Y.	27
Z.	29
Fiège Connector for 1/8" Wire	31
Fiège Connector for 5/16" Wire.	34
Typical Installation.	39
List of Material.	41

A

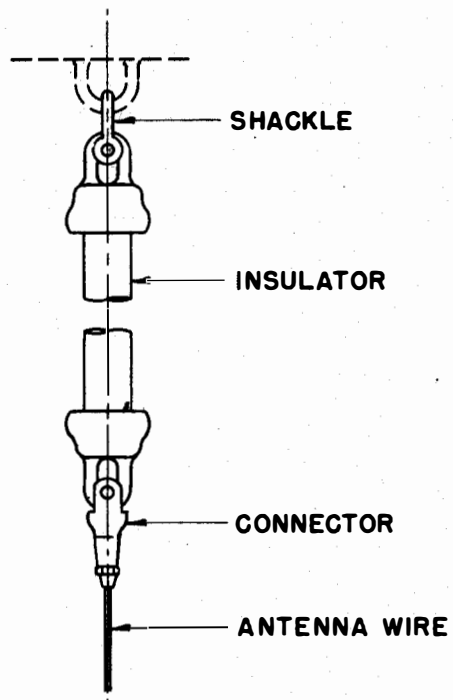

DTL.	A1		A2		A3		A4		A5			
SIZES NOM'L.	SIZE	PC. NO.	SIZE	PC. NO.	SIZE	PC. NO.	SIZE	PC. NO.	SIZE	PC. NO.		
SHACK.	$\frac{5}{16}$ "	25	$\frac{5}{16}$ "	25	$\frac{5}{16}$ "	25	$\frac{7}{16}$ "	26	$\frac{7}{16}$ "	26		
INSUL'R.	5"	3	10"	4	10"	4	15"	5	20"	6		
CONN'R.	$\frac{1}{8}$ "	7	$\frac{1}{8}$ "	7	$\frac{5}{16}$ "	8	$\frac{5}{16}$ "	8	$\frac{5}{16}$ "	8		
WIRE	$\frac{1}{8}$ "	1	$\frac{1}{8}$ "	1	$\frac{5}{16}$ "	2	$\frac{5}{16}$ "	2	$\frac{5}{16}$ "	2		

B

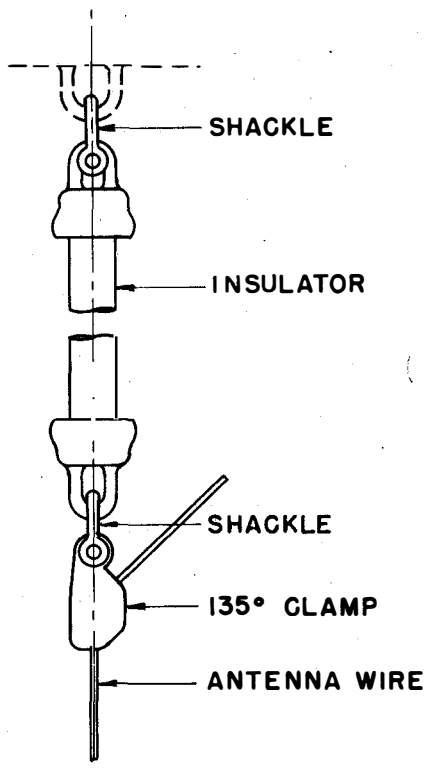

DTL.	B1	B2	B3	B4	B5			
SIZES NOM'L.	SIZE	PC. NO.	SIZE	PC. NO.	SIZE	PC. NO.	SIZE	PC. NO.
SHACK.	5/16"	25	5/16"	25	5/16"	25	7/16"	26
INSUL'R.	5"	3	10"	4	10"	4	15"	5
CLAMP	1/8"	13	1/8"	13	5/16"	19	5/16"	19
WIRE	1/8"	1	1/8"	1	5/16"	2	5/16"	2

2

C

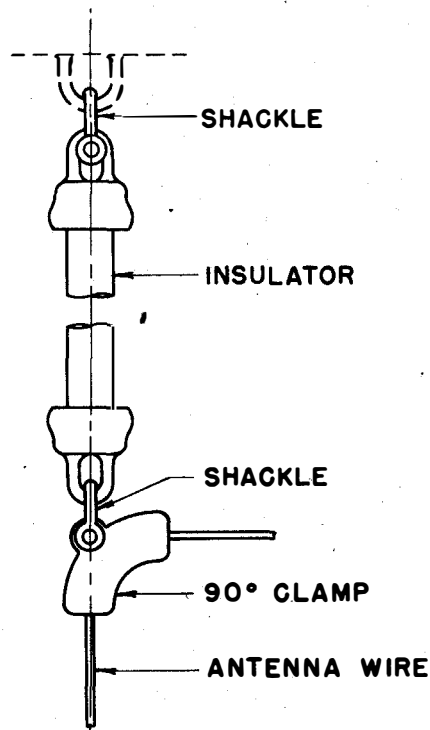

DTL.	C1	C2	C3	C4	C5			
SIZES NOM'L.	SIZE	PC. NO.	SIZE	PC. NO.	SIZE	PC. NO.	SIZE	PC. NO.
SHACK.	5/16"	25	5/16"	25	5/16"	25	7/16"	26
INSUL'R.	5"	3	10"	4	10"	4	15"	5
CLAMP	1/8"	14	1/8"	14	5/16"	20	5/16"	20
WIRE	1/8"	1	1/8"	1	5/16"	2	5/16"	2

3

D

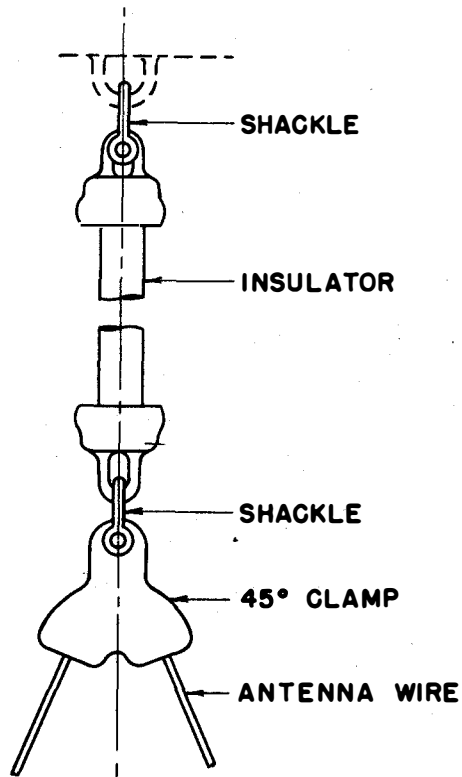

DTL.	D1		D2		D3		D4		D5			
SIZES NOM'L.	SIZE	PC. NO.	SIZE	PC. NO.	SIZE	PC. NO.	SIZE	PC. NO.	SIZE	PC. NO.		
SHACK.	5/16"	25	5/16"	25	5/16"	25	7/16"	26	7/16"	26		
INSUL'R.	5"	3	10"	4	10"	4	15"	5	20"	6		
CLAMP	1/8"	15	1/8"	15	5/16"	21	5/16"	21	5/16"	21		
WIRE	1/8"	1	1/8"	1	5/16"	2	5/16"	2	5/16"	2		

4

E

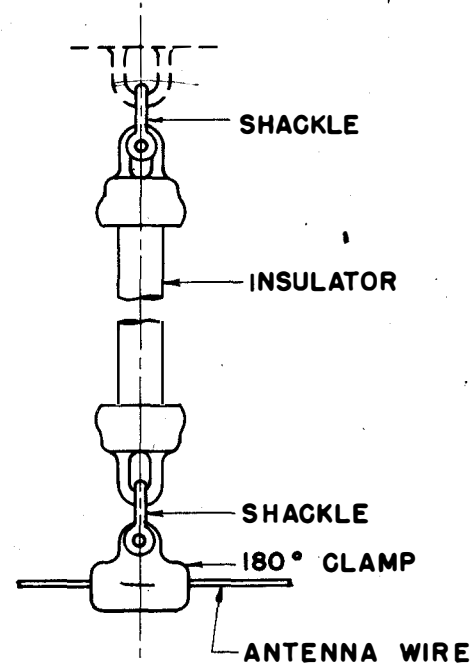

DTL.	E1		E2		E3		E4		E5			
SIZES NOM'L.	SIZE	PC. NO.	SIZE	PC. NO.	SIZE	PC. NO.	SIZE	PC. NO.	SIZE	PC. NO.		
SHACK.	5/16"	25	5/16"	25	5/16"	25	7/16"	26	7/16"	26		
INSUL'R.	5"	3	10"	4	10"	4	15"	5	20"	6		
CLAMP	1/8"	16	1/8"	16	5/16"	22	5/16"	22	5/16"	22		
WIRE	1/8"	1	1/8"	1	5/16"	2	5/16"	2	5/16"	2		

5

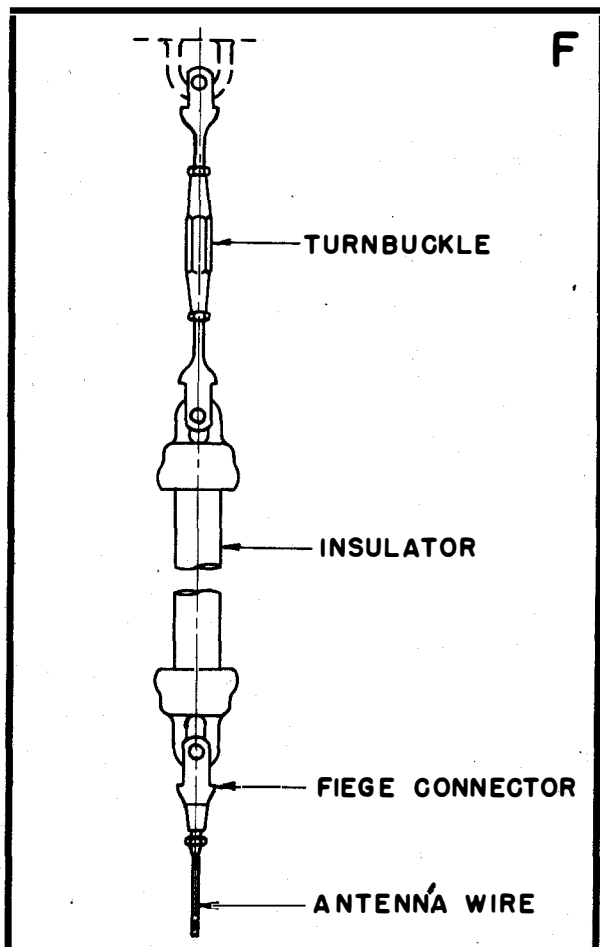

DTL.	F1	F2	F3	F4	F5			
SIZES NOM'L.	SIZE	PC. NO.	SIZE	PC. NO.	SIZE	PC. NO.	SIZE	PC. NO.
TURNB.	1/8"	11	1/8"	11	5/16"	12	5/16"	12
INSUL'R.	5"	3	10"	4	10"	4	15"	5
CONN'R.	1/8"	7	1/8"	7	5/16"	8	5/16"	8
WIRE	1/8"	1	1/8"	1	5/16"	2	5/16"	2

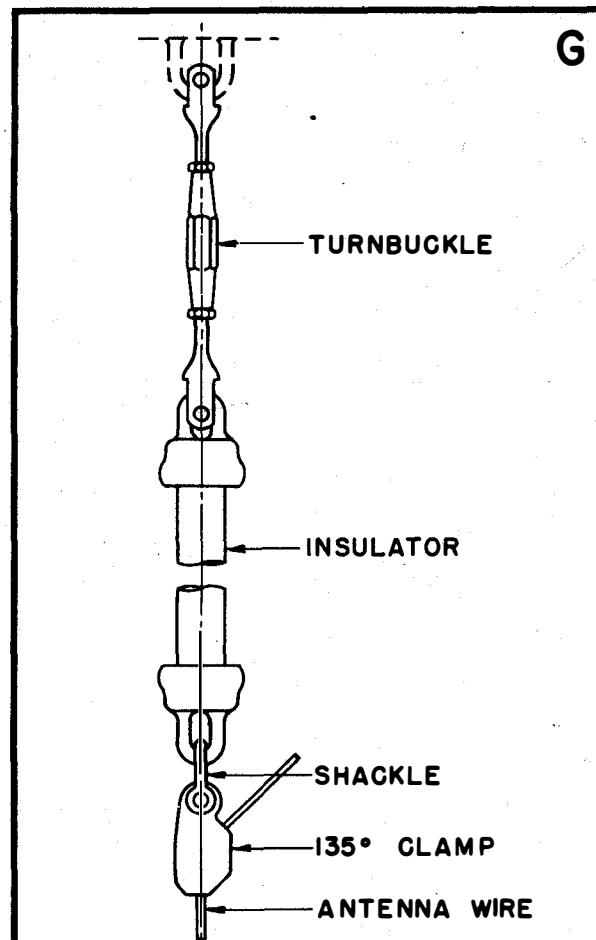

DTL.	G1	G2	G3	G4	G5			
SIZES NOM'L.	SIZE	PC. NO.	SIZE	PC. NO.	SIZE	PC. NO.	SIZE	PC. NO.
TURNB.	1/8"	11	1/8"	11	5/16"	12	5/16"	12
INSUL'R.	5"	3	10"	4	10"	4	15"	5
SHACK.	5/16"	25	5/16"	25	5/16"	25	7/16"	26
CLAMP	1/8"	13	1/8"	13	5/16"	19	5/16"	19
WIRE	1/8"	1	1/8"	1	5/16"	2	5/16"	2

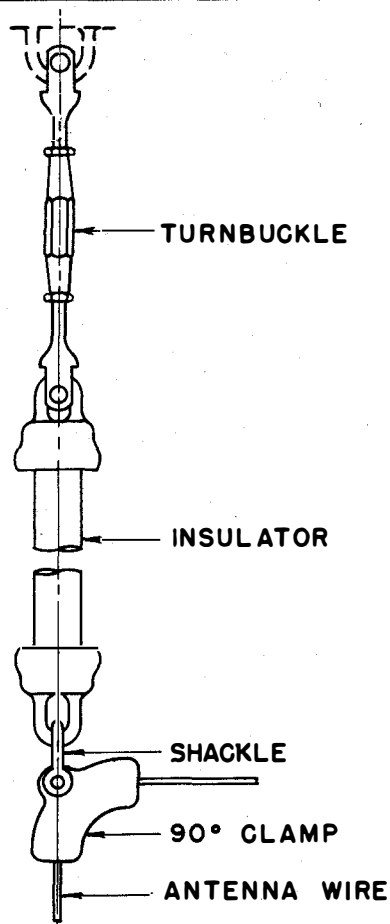

H

DTL.	H1	H2	H3	H4	H5					
SIZES NOM'L.	SIZE	PC. NO.	SIZE	PC. NO.	SIZE	PC. NO.	SIZE	PC. NO.		
TURNB.	1/8"	11	1/8"	11	5/16"	12	5/16"	12	5/16"	12
INSUL'R.	5"	3	10"	4	10"	4	15"	5	20"	6
SHACK.	5/16"	25	5/16"	25	5/16"	25	7/16"	26	7/16"	26
CLAMP	1/8"	14	1/8"	14	5/16"	20	5/16"	20	5/16"	20
WIRE	1/8"	1	1/8"	1	5/16"	2	5/16"	2	5/16"	2

8

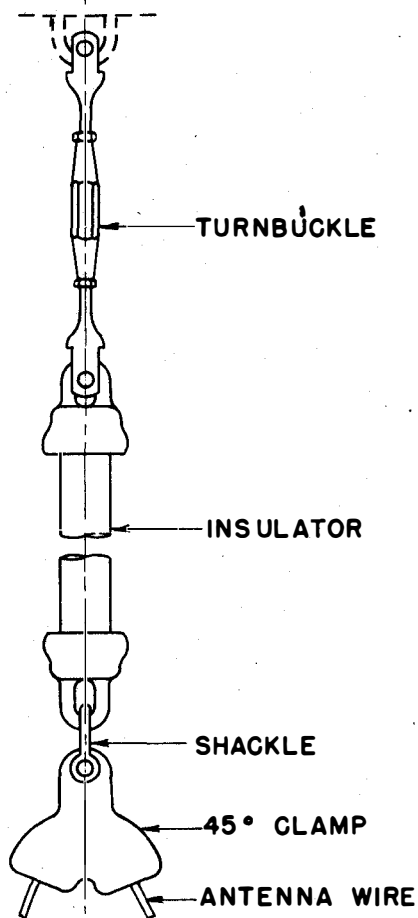

I

DTL.	I1	I2	I3	I4	I5					
SIZES NOM'L.	SIZE	PC. NO.	SIZE	PC. NO.	SIZE	PC. NO.	SIZE	PC. NO.		
TURNB.	1/8"	11	1/8"	11	5/16"	12	5/16"	12	5/16"	12
INSUL'R.	5"	3	10"	4	10"	4	15"	5	20"	6
SHACK.	5/16"	25	5/16"	25	5/16"	25	7/16"	26	7/16"	26
CLAMP	1/8"	15	1/8"	15	5/16"	21	5/16"	21	5/16"	21
WIRE	1/8"	1	1/8"	1	5/16"	2	5/16"	2	5/16"	2

9

J

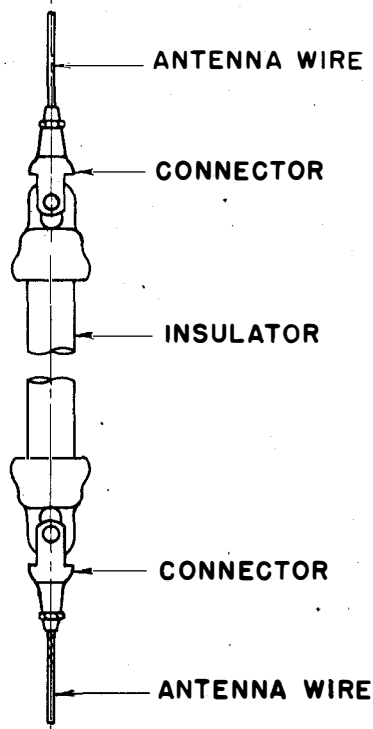

DTL.	J1		J2		J3		J4		J5	
SIZES NOM'L.	SIZE	PC. NO.	SIZE	PC. NO.	SIZE	PC. NO.	SIZE	PC. NO.	SIZE	PC. NO.
WIRE	1/8"	1	1/8"	1	5/16"	2	5/16"	2	5/16"	2
CONN'R.	1/8"	7	1/8"	7	5/16"	8	5/16"	8	5/16"	8
INSUL'R.	5"	3	10"	4	10"	4	15"	5	20"	6

10

K

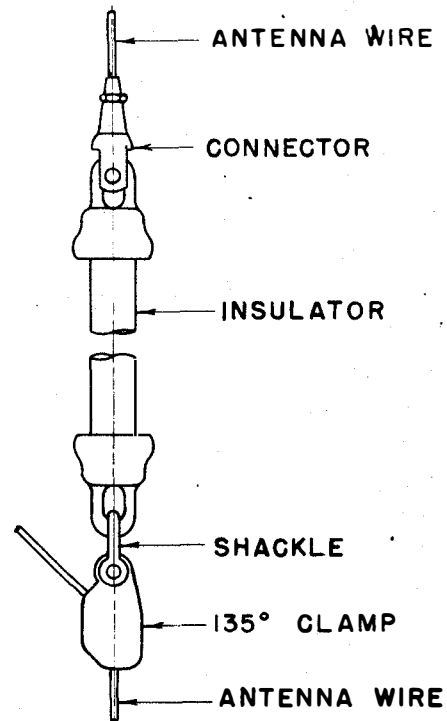

DTL.	K1		K2		K3		K4		K5	
SIZES NOM'L.	SIZE	PC. NO.	SIZE	PC. NO.	SIZE	PC. NO.	SIZE	PC. NO.	SIZE	PC. NO.
WIRE	1/8"	1	1/8"	1	5/16"	2	5/16"	2	5/16"	2
CONN'R.	1/8"	7	1/8"	7	5/16"	8	5/16"	8	5/16"	8
INSUL'R.	5"	3	10"	4	10"	4	15"	5	20"	6
SHACK.	5/16"	25	5/16"	25	5/16"	25	7/16"	26	7/16"	26
CLAMP	1/8"	13	1/8"	13	5/16"	19	5/16"	19	5/16"	19

11

L

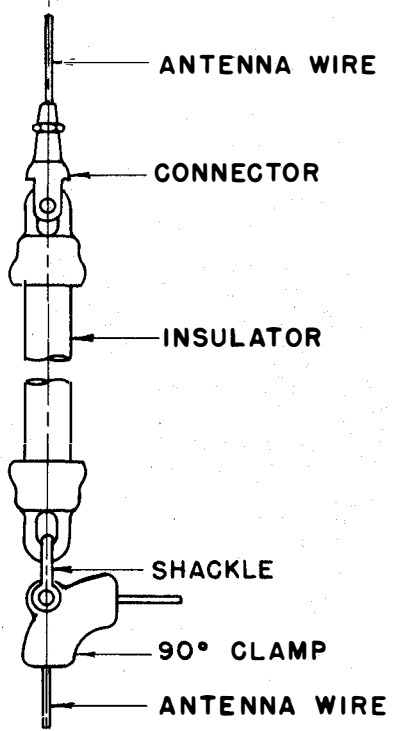

M

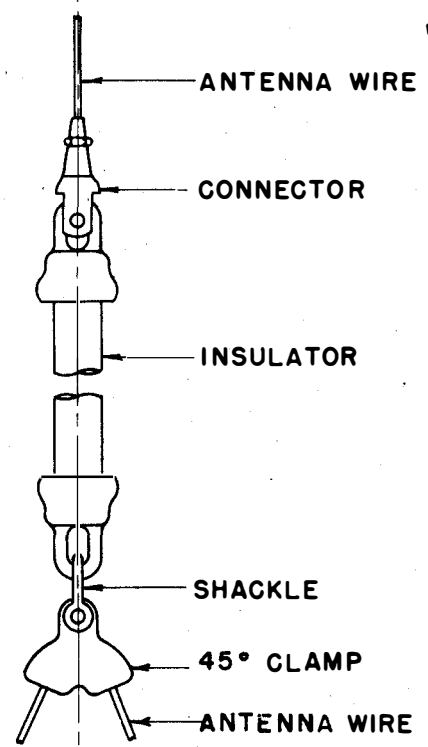

DTL.	L1	L2	L3	L4	L5							
SIZES NOM'L.	SIZE	PC. NO.	SIZE	PC. NO.	SIZE	PC. NO.	SIZE	PC. NO.				
WIRE	1/8"	1	1/8"	1	5/16"	2	5/16"	2	5/16"	2		
CONN'R.	1/8"	7	1/8"	7	5/16"	8	5/16"	8	5/16"	8		
INSUL'R.	5"	3	10"	4	10"	4	15"	5	20"	6		
SHACK.	5/16"	25	5/16"	25	5/16"	25	7/16"	26	7/16"	26		
CLAMP	1/8"	14	1/8"	14	5/16"	20	5/16"	20	5/16"	20		

DTL.	M1	M2	M3	M4	M5							
SIZES NOM'L.	SIZE	PC. NO.	SIZE	PC. NO.	SIZE	PC. NO.	SIZE	PC. NO.				
WIRE	1/8"	1	1/8"	1	5/16"	2	5/16"	2	5/16"	2		
CONN'R.	1/8"	7	1/8"	7	5/16"	8	5/16"	8	5/16"	8		
INSUL'R.	5"	3	10"	4	10"	4	15"	5	20"	5		
SHACK.	5/16"	25	5/16"	25	5/16"	25	7/16"	26	7/16"	26		
CLAMP	1/8"	15	1/8"	15	5/16"	21	5/16"	21	5/16"	21		

N

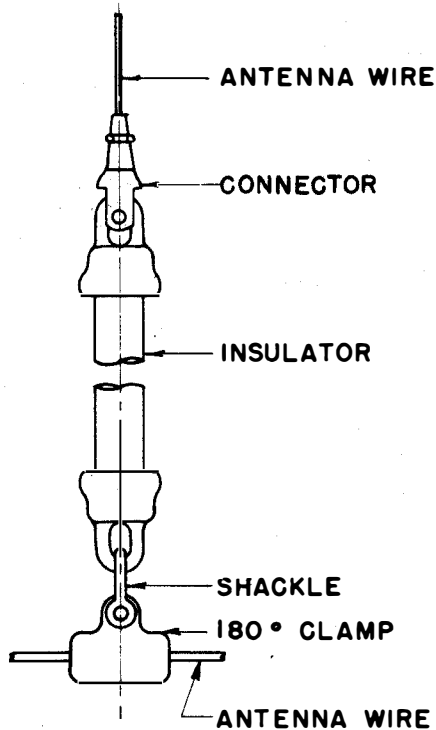

DTL.	N1	N2	N3	N4	N5	N6
SIZES NOM'L.	SIZE	PC. NO.	SIZE	PC. NO.	SIZE	PC. NO.
WIRE	1/8" 1	1/8" 1	5/16" 2	5/16" 2	5/16" 2	1/8" 1
CONN'R.	1/8" 7	1/8" 7	5/16" 8	5/16" 8	5/16" 8	1/8" 7
INSUL'R.	5" 3	10" 4	10" 4	15" 5	20" 6	20" 6
SHACK.	5/16" 25	5/16" 25	5/16" 25	7/16" 26	7/16" 26	7/16" 26
CLAMP	1/8" 16	1/8" 16	5/16" 22	5/16" 22	5/16" 22	5/16" 22
WIRE	1/8" 1	1/8" 1	5/16" 2	5/16" 2	5/16" 2	5/16" 2

14

'O

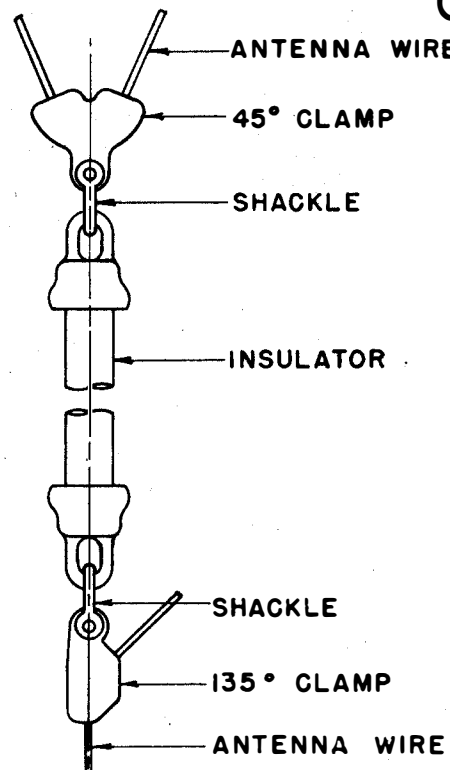

DTL.	O1	O2	O3	O4	O5	
SIZES NOM'L.	SIZE	PC. NO.	SIZE	PC. NO.	SIZE	PC. NO.
WIRE	1/8" 1	1/8" 1	5/16" 2	5/16" 2	5/16" 2	
CLAMP	1/8" 15	1/8" 15	5/16" 21	5/16" 21	5/16" 21	
SHACK.	5/16" 25	5/16" 25	5/16" 25	7/16" 26	7/16" 26	
INSUL'R.	5" 3	10" 4	10" 4	15" 5	20" 6	
CLAMP	1/8" 13	1/8" 13	5/16" 19	5/16" 19	5/16" 19	

15

P

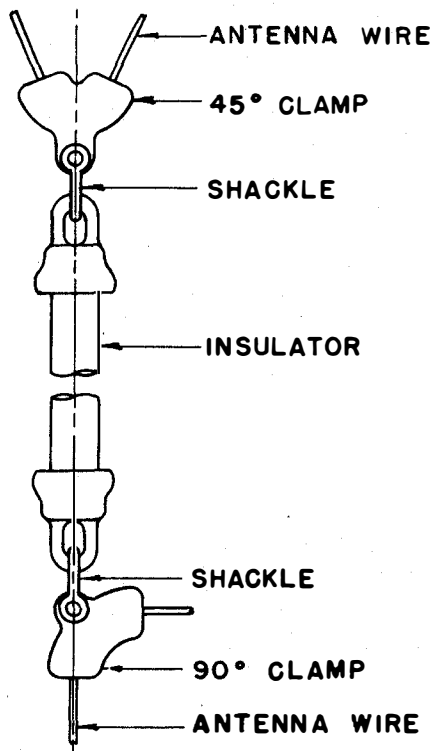

DTL.	P1	P2	P3	P4	P5					
SIZES NOM'L.	SIZE	PC. NO.	SIZE	PC. NO.	SIZE	PC. NO.	SIZE	PC. NO.		
WIRE	1/8	1	1/8	1	5/16	2	5/16	2		
CLAMP	1/8	15	1/8	15	5/16	21	5/16	21		
SHACK.	5/16	25	5/16	25	5/16	25	7/16	26	7/16	26
INSUL'R	5"	3	10"	4	10"	4	15"	5	20"	6
CLAMP	1/8	14	1/8	14	5/16	20	5/16	20		

Q

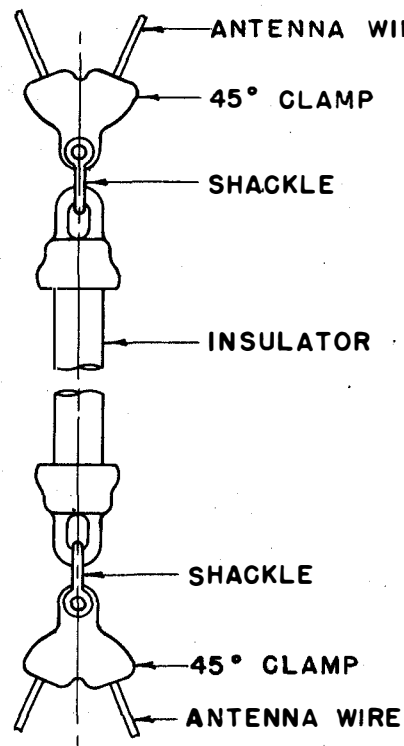

DTL.	Q1	Q2	Q3	Q4	Q5					
SIZES NOM'L.	SIZE	PC. NO.	SIZE	PC. NO.	SIZE	PC. NO.	SIZE	PC. NO.		
WIRE	1/8	1	1/8	1	5/16	2	5/16	2		
CLAMP	1/8	15	1/8	15	5/16	21	5/16	21		
SHACK.	5/16	25	5/16	25	5/16	25	7/16	26	7/16	26
INSUL'R.	5"	3	10"	4	10"	4	15"	5	20"	6

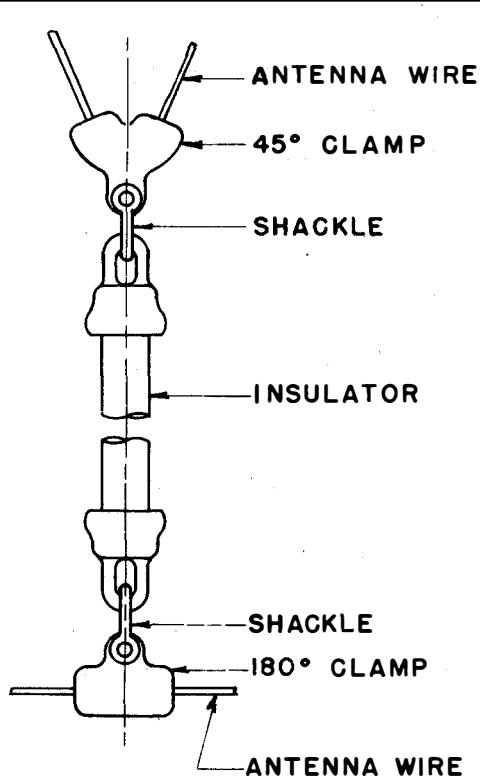

DTL.	R1	R2	R3	R4	R5	R6
SIZES NOM'L	SIZE PC.NO.	SIZE PC.NO.	SIZE PC.NO.	SIZE PC.NO.	SIZE PC.NO.	SIZE PC.NO.
WIRE	1/8" 1	1/8" 1	5/16" 2	5/16" 2	5/16" 2	1/8" 1
CLAMP	1/8" 15	1/8" 15	5/16" 21	5/16" 21	5/16" 21	1/8" 15
SHACK.	5/16" 25	5/16" 25	5/16" 25	7/16" 26	7/16" 26	7/16" 26
INSUL'R.	5" 3	10" 4	10" 4	15" 5	20" 6	20" 6
CLAMP	1/8" 16	1/8" 16	5/16" 22	5/16" 22	5/16" 22	5/16" 22
WIRE	1/8" 1	1/8" 1	5/16" 2	5/16" 2	5/16" 2	5/16" 2

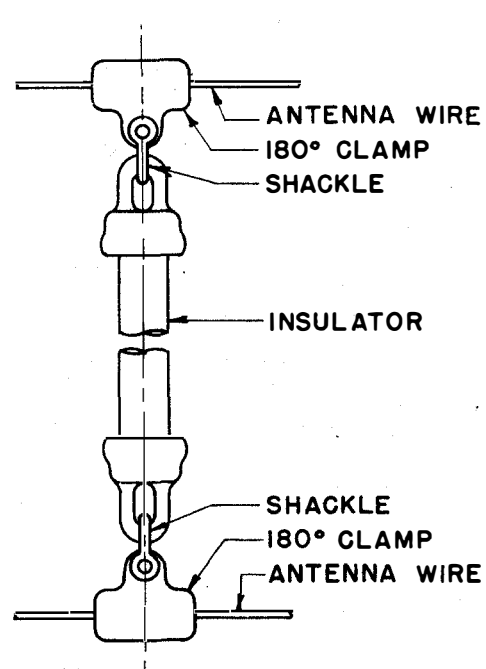

DTL.	S1	S2	S3	S4	S5	S6
SIZES NOM'L	SIZE PC.NO.	SIZE PC.NO.	SIZE PC.NO.	SIZE PC.NO.	SIZE PC.NO.	SIZE PC.NO.
WIRE	1/8" 1	1/8" 1	5/16" 2	5/16" 2	5/16" 2	1/8" 1
CLAMP	1/8" 16	1/8" 16	5/16" 22	5/16" 22	5/16" 22	1/8" 16
SHACK.	5/16" 25	5/16" 25	5/16" 25	7/16" 26	7/16" 26	7/16" 26
INSUL R.	5" 3	10" 4	10" 4	15" 5	20" 6	20" 6
CLAMP	1/8" 16	1/8" 16	5/16" 22	5/16" 22	5/16" 22	5/16" 22
WIRE	1/8" 1	1/8" 1	5/16" 2	5/16" 2	5/16" 2	5/16" 2

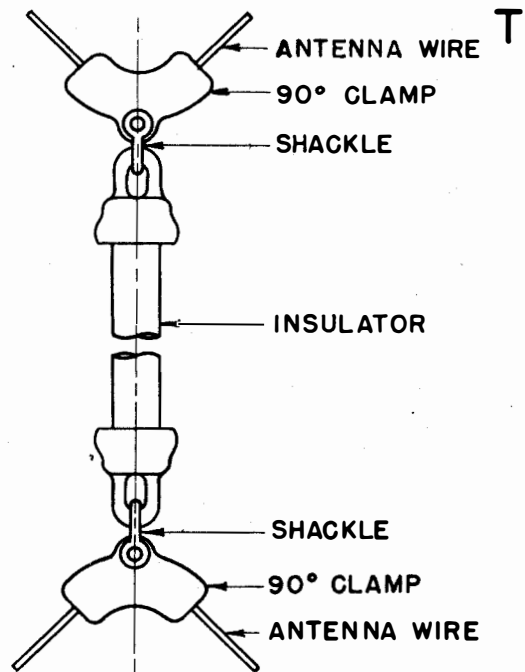

DTL.	T1	T2	T3	T4	T5					
SIZES NOM'L.	SIZE	PC. NO.	SIZE	PC. NO.	SIZE	PC. NO.	SIZE	PC. NO.	SIZE	PC. NO.
WIRE	1/8	1	1/8	1	5/16	2	5/16	2	5/16	2
CLAMP	1/8	14	1/8	14	5/16	20	5/16	20	5/16	20
SHACK.	5/16	25	5/16	25	5/16	25	7/16	26	7/16	26
INSUL'R.	5"	3	10"	4	10"	4	15"	5	20"	6

20

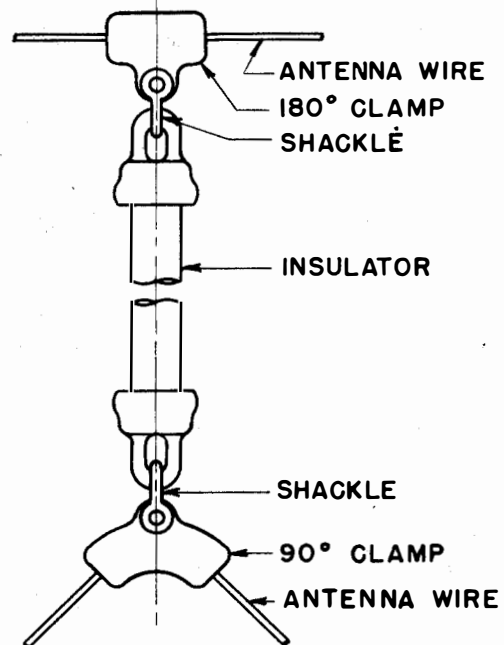

DTL.	U1	U2	U3	U4	U5	U6				
SIZES NOM'L.	SIZE	PC. NO.	SIZE	PC. NO.	SIZE	PC. NO.	SIZE	PC. NO.	SIZE	PC. NO.
WIRE	1/8	1	1/8	1	5/16	2	5/16	2	5/16	2
CLAMP	1/8	16	1/8	16	5/16	22	5/16	22	5/16	22
SHACK.	5/16	25	5/16	25	5/16	25	7/16	26	7/16	26
INSUL'R.	5"	3	10"	4	10"	4	15"	5	20"	6
CLAMP	1/8	14	1/8	14	5/16	20	5/16	20	5/16	20
WIRE	1/8	1	1/8	1	5/16	2	5/16	2	5/16	2

21

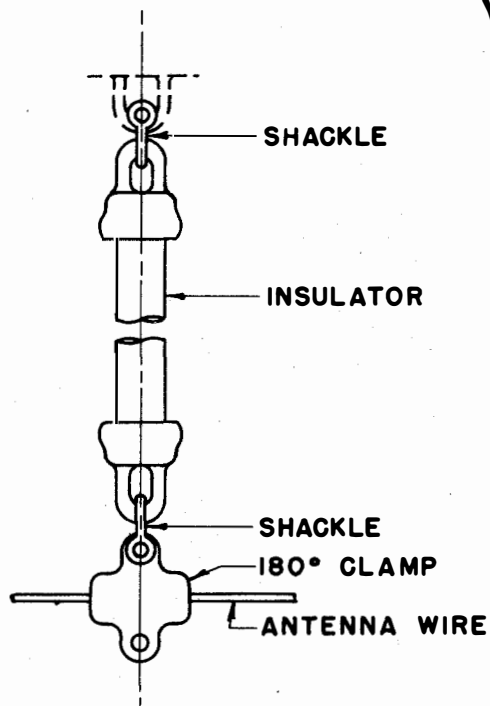

DTL.	V 1	V 2	V 3	V 4	V 5
SIZES NOM'L.	SIZE PC. NO.	SIZE PC. NO.	SIZE PC. NO.	SIZE PC. NO.	SIZE PC. NO.
SHACK.	5/16" 25	5/16" 25	5/16" 25	7/16" 26	7/16" 26
INSUL'R.	5" 3	10" 4	10" 4	15" 5	20" 6
CLAMP	1/8" 17	1/8" 17	5/16" 23	5/16" 23	5/16" 23
WIRE	1/8" 1	1/8" 1	5/16" 2	5/16" 2	5/16" 2

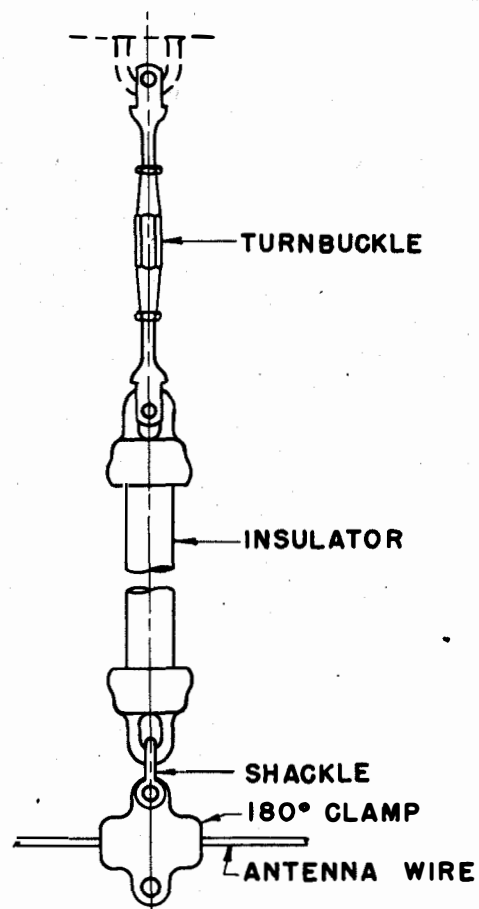

DTL.	W 1	W 2	W 3	W 4	W 5
SIZES NOM'L.	SIZE PC. NO.	SIZE PC. NO.	SIZE PC. NO.	SIZE PC. NO.	SIZE PC. NO.
TURNB.	1/8" 11	1/8" 11	5/16" 12	5/16" 12	5/16" 12
INSUL'R.	5" 3	10" 4	10" 4	15" 5	20" 6
SHACK.	5/16" 25	5/16" 25	5/16" 25	7/16" 26	7/16" 26
CLAMP	1/8" 17	1/8" 17	5/16" 23	5/16" 23	5/16" 23
WIRE	1/8" 1	1/8" 1	5/16" 2	5/16" 2	5/16" 2

CONNECTOR
TYPE 2WC6C



CONNECTOR
TYPE 5WC9C

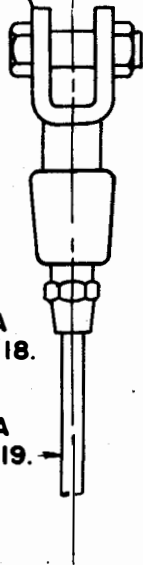

ANTENNA
WIRE 7-⁵/₁₆"

ANTENNA
WIRE 6x19.

DTL.	X1	X2					
SIZES NOM'L.	SIZE	PC. NO.	SIZE	PC. NO.			
CONN'R.	¹ / ₈ "	7	⁵ / ₁₆ "	8			
WIRE	¹ / ₈ "	1	⁵ / ₁₆ "	2			

24

TURNBUCKLE
TYPE 2WT6C



TURNBUCKLE
TYPE 5WT9C

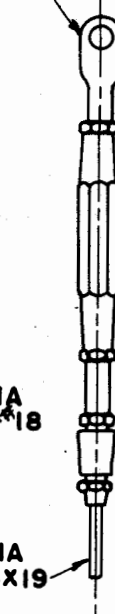

ANTENNA
WIRE 7-⁵/₁₆"

ANTENNA
WIRE 6x19

DTL.	X3	X4					
SIZES NOM'L.	SIZE	PC. NO.	SIZE	PC. NO.			
TURNB.	¹ / ₈ "	9	⁵ / ₁₆ "	10			
WIRE	¹ / ₈ "	1	⁵ / ₁₆ "	2			

25

X

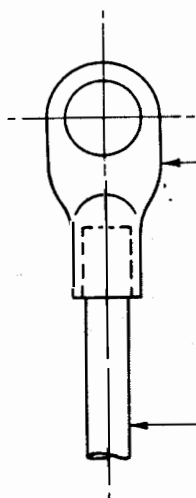

TERMINAL, PC. 27
SPECIFY SIZE
(THE TERMINAL
PROVIDED WITH
ENTERING INSUL-
ATORS NEED
NOT BE SPECIFIED)

WIRE

DTL. X5 X6

SIZES NOM'L.	SIZE	PC. NO.	SIZE	PC. NO.						
TERM'L.	-	27	-	27						
WIRE	1/8"	1	5/16"	2						

26

Y

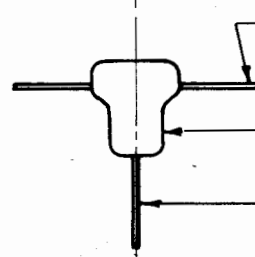

ANTENNA
WIRE (7-*18)

TEE CLAMP
TYPE F-2, PC. 18

ANTENNA
WIRE (7-*18)

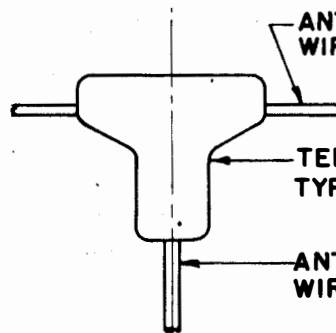

ANTENNA
WIRE (6 x 19)

TEE CLAMP
TYPE F-5, PC. 24

ANTENNA
WIRE (6 x 19) 5/16"

DTL. Y1 Y2

SIZES NOM'L.	SIZE	PC. NO.	SIZE	PC. NO.						
WIRE	1/8"	1	5/16"	2						
CLAMP	1/8"	18	5/16"	24						

27

Y

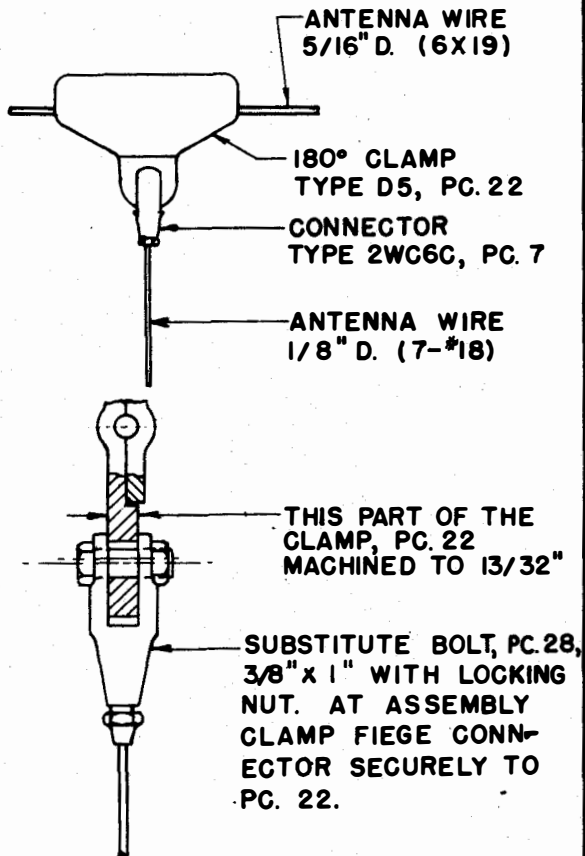

DETAIL Y3

Z

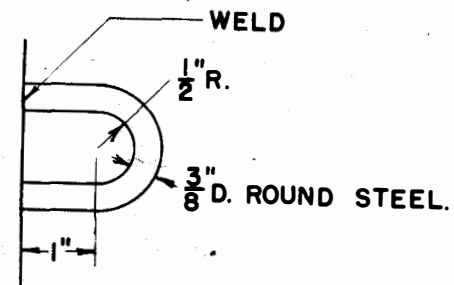

Z1 PC. 29

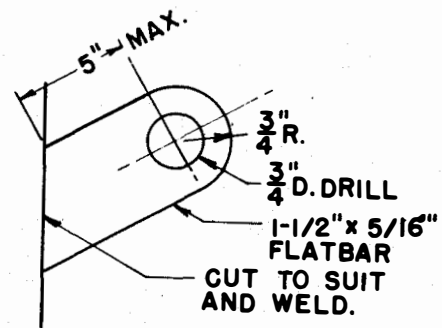

Z2 PC. 30

DETAIL Z1-STAPLE

DETAIL Z2-PADEYE
SPECIFY LENGTH

**INSTRUCTIONS FOR INSTALLING
FIEGE CONNECTORS ON 7-#18
BRONZE ANTENNA WIRE.**

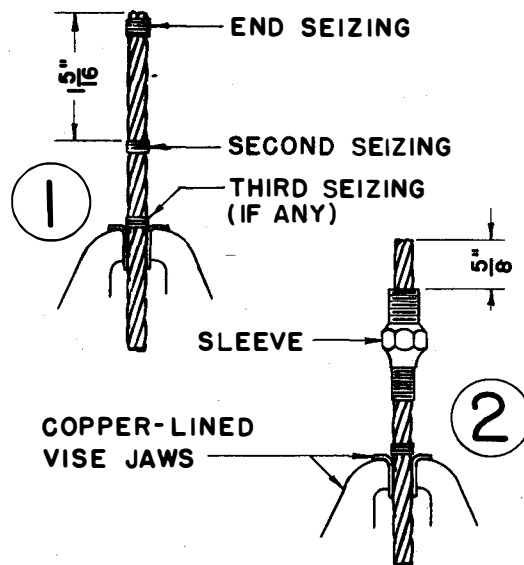

(1) REMOVE INSULATION, IF ANY, AND GRIP THE STRAND VERTICALLY IN A VISE WITH COPPER-LINED JAWS. IF THERE IS ONLY ONE SEIZING IN USE, APPLY A SECOND SEIZING AS SHOWN.

(2) BEFORE APPLYING THE SLEEVE, DRIVE THE END SEIZING CLOSE ENOUGH TO THE END OF THE STRAND SO THE SLEEVE CAN BE EASILY STARTED OVER IT. USING A BAR OF COPPER OR A PIECE OF HARDWOOD TO PROTECT THE EDGE OF THE SLEEVE, DRIVE THE SLEEVE AND SEIZING DOWN ALONG THE STRAND UNTIL IT PROJECTS TO THE DIMENSION SHOWN. WITH THE SOCKET SCREWED ON A FEW TURNS, MOST OF THE REQUIRED DISTANCE CAN BE OBTAINED BY HAMMERING THE END OF THE FITTING.

INSTRUCTIONS (CONTINUED)

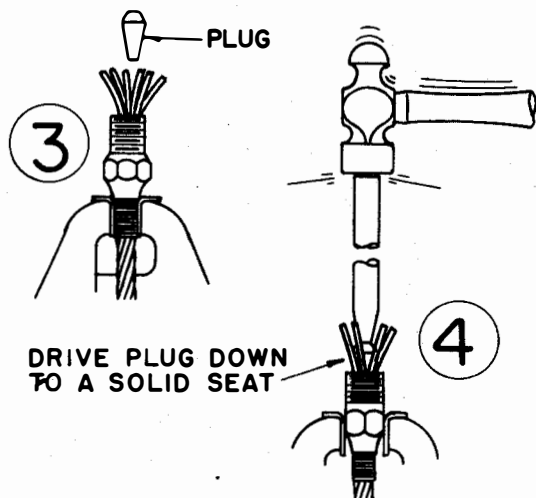

(3) GRIP THE STRAND IN THE VISE OVER THE SEIZINGS SO THE END OF THE SLEEVE BEARS SOLIDLY AGAINST THE VISE JAWS. FAN OUT THE WIRES SO THEY ARE UNTWISTED AND PROJECT STRAIGHT FROM THE SLEEVE. UNTWIST THE WIRES WITH PLIERS SO THEY OPEN OUT AS FAR AS POSSIBLE TO FORM A SYMMETRICAL ROSETTE AND APPLY THE PLUG.

(4) PROVIDE A ROUND BAR OF STEEL WITH END FACED OFF SQUARE. APPLY THIS PUNCH AND DRIVE THE PLUG DOWN TO A MODERATE SEAT SUFFICIENT TO HOLD THE STRAND, SLEEVE AND PLUG SAFELY TOGETHER, THEN GRIP THE SLEEVE SECURELY IN THE VISE BY THE HEX. DRIVE THE PLUG IN SOLIDLY, MAKING SURE THAT IT GOES DOWN AS FAR AS POSSIBLE.

INSTRUCTIONS (CONTINUED)

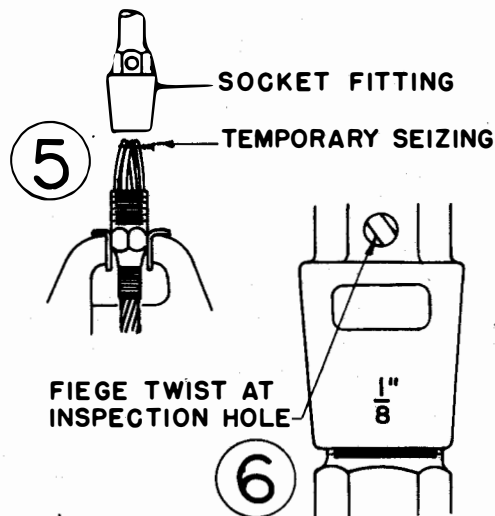

(5) WITH THE FINGERS, BEND ALL WIRES TOGETHER BEHIND THE PLUG; OR IF NECESSARY AGAIN APPLY A TEMPORARY ONE-TURN SEIZING WIRE AND TIGHTEN WITH PLIERS TO GET ALL WIRES ENTERED IN THE OPEN END OF THE SOCKET. AFTER THE WIRES HAVE ENTERED THE SOCKET, REMOVE THE TEMPORARY SEIZING. THEN PUSH AND TWIST THE SOCKET DOWN TO THE SLEEVE UNTIL THE THREADS ARE ENGAGED. SCREW THE SOCKET DOWN FIRMLY. IF PROPERLY INSTALLED, THERE WILL BE ONLY ONE OR TWO THREADS VISIBLE ON THE SLEEVE. REMOVE ALL SEIZINGS.

(6) VIEW THE FIEGE TWIST AT THE INSPECTION HOLE. IF THE INSTALLATION HAS BEEN PROPERLY MADE, THE WIRES WILL BE FULLY VISIBLE AND TWISTED ACROSS THE INSPECTION HOLE AT AN ANGLE TO THE AXIS OF THE ROPE AND FITTING.

**INSTRUCTIONS FOR INSTALLING
FIEGE CONNECTORS ON 5/16" D.
(6X19) BRONZE WIRE ROPE.**

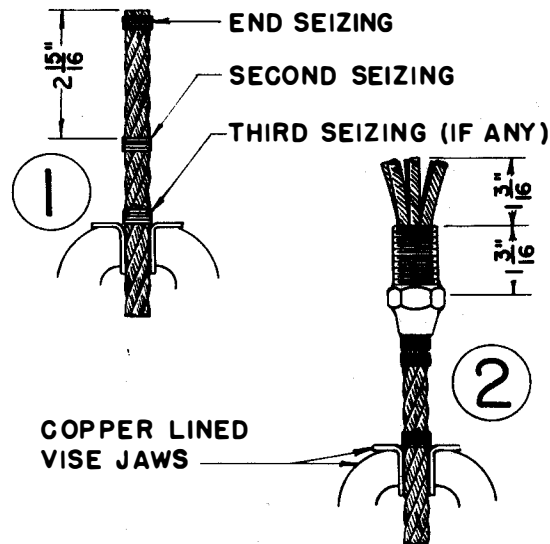

(1) GRIP THE ROPE VERTICALLY IN A VISE WITH COPPER-LINED JAWS. IF THERE IS ONLY ONE SEIZING IN USE, APPLY A SECOND SEIZING AS SHOWN.

(2) BEFORE APPLYING THE SLEEVE, DRIVE THE END SEIZING CLOSE ENOUGH TO THE END OF THE ROPE SO THE SLEEVE CAN BE EASILY STARTED OVER IT. USING A BAR OF COPPER OR A PIECE OF HARDWOOD TO PROTECT THE EDGE OF THE SLEEVE, DRIVE THE SLEEVE AND THE SEIZINGS DOWN ALONG THE ROPE UNTIL IT PROJECTS TO THE DIMENSION SHOWN. WITH THE SOCKET SCREWED ON A FEW TURNS, MOST OF THE REQUIRED DISTANCE CAN BE OBTAINED BY HAMMERING THE END OF THE FITTING.

INSTRUCTIONS (CONTINUED)

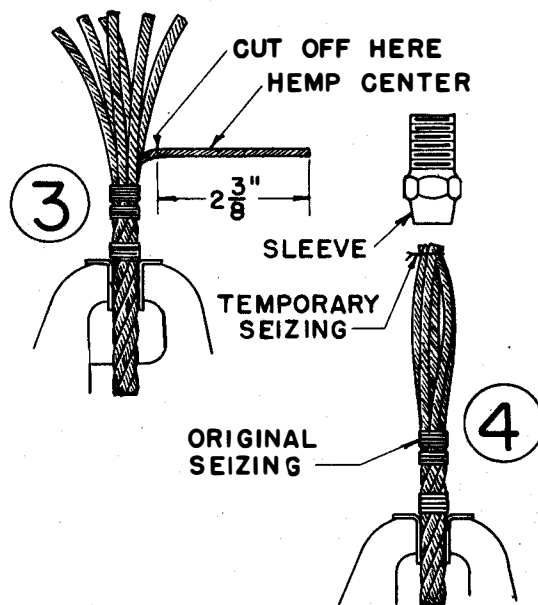

(3) AFTER THE SEIZINGS HAVE BEEN DRIVEN TO THE CORRECT LOCATION, GRIP THE ROPE IN THE VISE JUST BELOW THE SEIZINGS AND REMOVE THE SLEEVE TEMPORARILY. PULL THE HEMP CENTER OUT TO ONE SIDE BETWEEN STRANDS FAR ENOUGH SO THAT IT CAN BE CUT OFF TO DIMENSION SHOWN. THEN PUSH THE HEMP STUB BACK INTO THE CENTER OF THE ROPE.

(4) APPLY THE SLEEVE AS FOLLOWS. WITH THE FINGERS OR WITH A TEMPORARY ONE TURN SEIZING WIRE TIGHTENED WITH PLIERS COMPRESS THE STRANDS TOGETHER AT THE TOP UNTIL THE SLEEVE CAN BE TWISTED AND PUSHED OVER THE ROPE. REMOVE THE TEMPORARY SEIZING AND FORCE THE SLEEVE DOWN TO THE ORIGINAL SEIZING.

INSTRUCTIONS (CONTINUED)

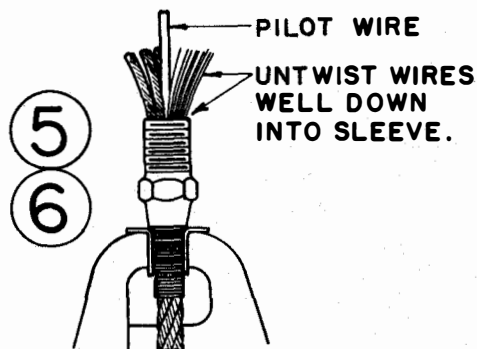

(5) GRIP THE ROPE IN THE VISE OVER THE SEIZINGS SO THE END OF THE SLEEVE BEARS SOLIDLY AGAINST THE VISE JAWS. BEFORE BEGINNING TO BROOM OUT THE WIRES, SHARPEN A LENGTH OF STIFF STEEL OR COPPER WIRE AND ANCHOR THE POINT IN THE TOP OF THE HEMP STUB. ITS LENGTH SHOULD BE A FEW INCHES LONGER THAN THE PROJECTING ROPE END. THE PURPOSE OF THIS PILOT WIRE IS TO FACILITATE FINDING THE CENTER OF THE ROPE AFTER THE STRANDS HAVE BEEN BROOMED OUT, AS WILL BE APPARENT IN PARAGRAPH 7,

(6) BROOM OUT ALL STRANDS BY UNTWISTING THEM WITH PLIERS. IT MAY BE CONVENIENT TO USE TWO SHORT PIECES OF STIFF WIRE INSERTED BEHIND A STRAND TO ISOLATE IT FROM THE OTHERS WHILE IT IS BEING WORKED ON. BE SURE THE STRAND IS UNTWISTED WELL DOWN INTO THE SLEEVE. REMOVE THE ROPE FROM THE VISE. IT IS BEST TO THOROUGHLY WASH OUT ALL GREASE IN GASOLINE. USE A BOTTLE BRUSH WITH WHICH TO PENETRATE WELL DOWN INTO THE SLEEVE BETWEEN ALL WIRE AS FAR AS POSSIBLE.

INSTRUCTIONS (CONTINUED)

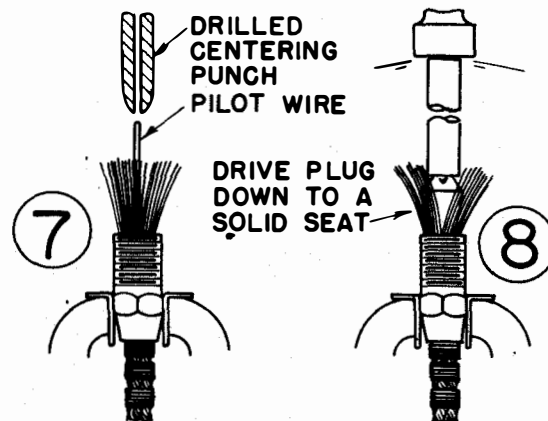

(7) THE PLUG CAN BE MORE EASILY INSTALLED AND WILL BE BETTER-CENTERED IF THE FOLLOWING PROCEDURE IS USED. PROVIDE A ROUND BAR OF STEEL WITH A HOLE LENGTHWISE THROUGH THE AXIS; AND WITH A POINT SOMEWHAT MORE BLUNT THAN THE CENTER PLUG, AND SLIGHTLY ROUNDED. DRIVE THIS CENTERING PUNCH DOWN OVER THE PILOT WIRE INTO THE CENTER OF THE BROOMED-OUT STRANDS TO A SOLID SEAT. THIS WILL GIVE THE WIRES ENOUGH SET TO ENSURE THE PLUG FINDING THE BEST CENTER POSITION FOR FINAL ASSEMBLY.

(8) REMOVE FIRST THE PILOT WIRE, THEN THE CENTERING PUNCH, TAKING CARE TO DISTURB THE SET OF THE WIRES BEHIND IT AS LITTLE AS POSSIBLE. INSERT THE SOLID PLUG AND WITH HAMMER AND ORDINARY PUNCH DRIVE THE PLUG DOWN TO A MODERATE SEAT SUFFICIENT TO HOLD THE ROPE, SLEEVE AND PLUG SAFELY TOGETHER, THEN GRIP THE SLEEVE SECURELY IN THE VISE BY THE HEX. DRIVE THE PLUG IN SOLIDLY, MAKING SURE THAT IT GOES DOWN AS FAR AS POSSIBLE.

INSTRUCTIONS (CONTINUED)

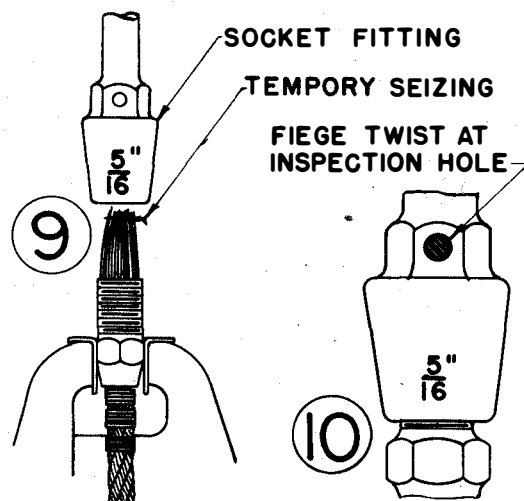

(9) WITH THE FINGERS, BEND ALL WIRES TOGETHER BEHIND THE PLUG; OR IF NECESSARY AGAIN APPLY A TEMPORARY ONE TURN SEIZING WIRE AND TIGHTEN WITH PLIERS TO GET ALL WIRES ENTERED IN THE OPEN END OF THE SOCKET. AFTER THE WIRES HAVE ENTERED THE SOCKET, REMOVE THE TEMPORARY SEIZING. THEN PUSH AND TWIST THE SOCKET DOWN TO THE SLEEVE TILL THE THREADS ARE ENGAGED. SCREW THE SOCKET DOWN FIRMLY. IF PROPERLY INSTALLED, THERE WILL BE ONLY ONE OR TWO THREADS VISIBLE ON THE SLEEVE. REMOVE ALL SEIZINGS.

(10) VIEW THE FIEGE TWIST AT THE INSPECTION HOLE. IF THE INSTALLATION HAS BEEN PROPERLY MADE, THE WIRES WILL BE FULLY VISIBLE AND TWISTED ACROSS THE INSPECTION HOLE AT AN ANGLE TO THE AXIS OF THE ROPE AND FITTINGS.

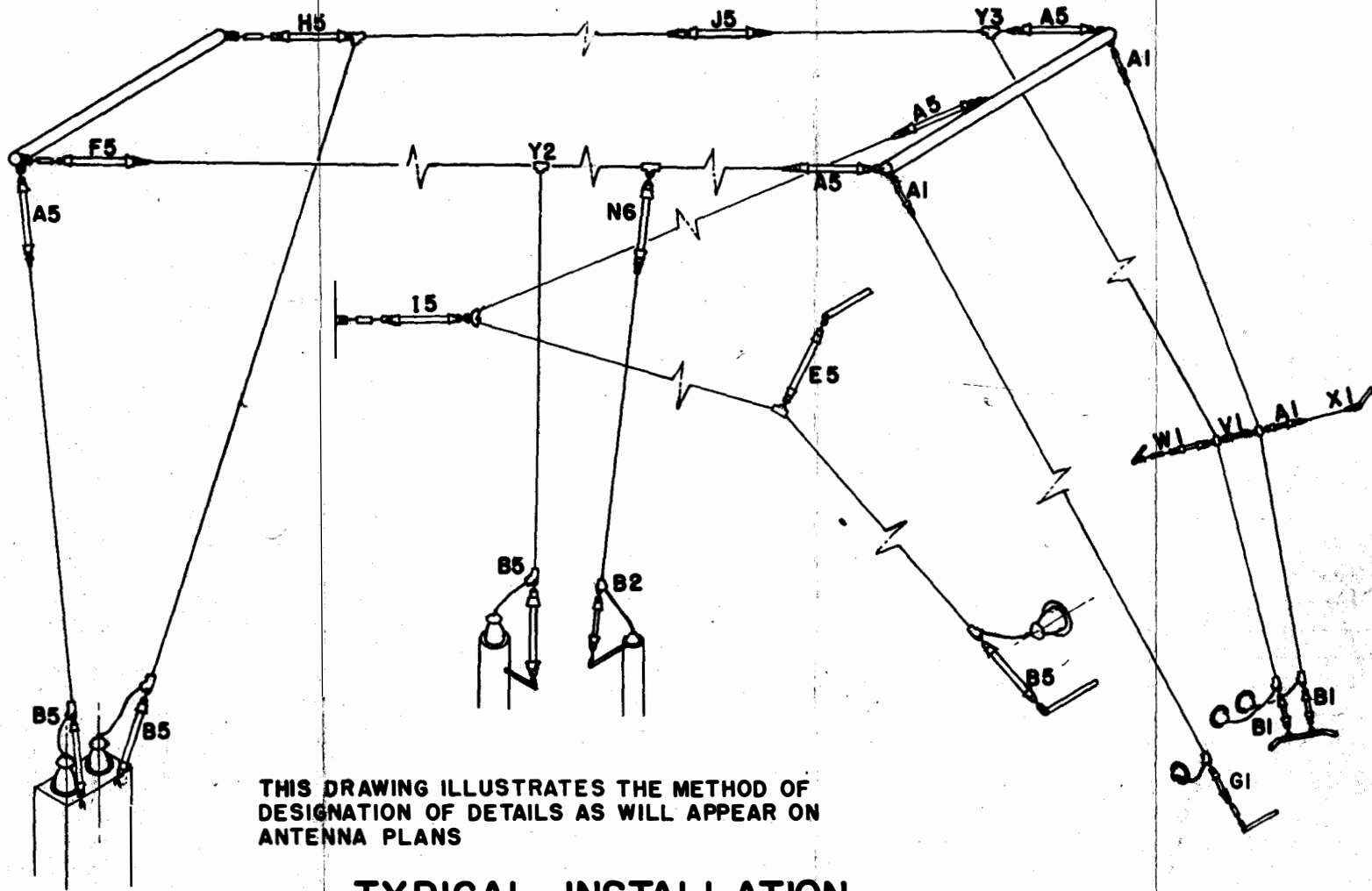

THIS DRAWING ILLUSTRATES THE METHOD OF DESIGNATION OF DETAILS AS WILL APPEAR ON ANTENNA PLANS

TYPICAL INSTALLATION.

