

NAVSHIPS 900,121(A)

# SHIPBOARD ANTENNA DETAILS

CHAPTER 3

## ANTENNA MULTICOUPLERS

BUREAU OF SHIPS

NAVY DEPARTMENT

Page Number	Change in Effect	Numbers	Change in Effect
Title Page	Original	3-1 to	
A Page	Original	3-60	Original
i to v	Original	i-1 to i-4	Original

TABLE OF CONTENTS

SECTION 3-1. INTRODUCTION		SECTION 3-2. VHF/UHF MULTICOUPLERS (cont'd)	
Paragraph	Page	Paragraph	Page
1. General.....	3-1	(6) Weight.....	3-8
2. Types of Multicouplers .....	3-1	(7) Standard Navy Stock Number.....	3-8
SECTION 3-2. VHF/UHF MULTICOUPLERS		d. Installation.....	3-8
1. Antenna Coupler		3. Antenna Coupler	
CU-255/UR.....	3-3	CU-274/UR.....	3-11
a. General Description .....	3-3	a. General Description.....	3-11
b. Main Components.....	3-3	b. Main Components.....	3-11
c. Reference Data.....	3-3	c. Reference Data.....	3-11
(1) Frequency Range.....	3-3	(1) Frequency Range.....	3-11
(2) Power Required for Automatic Tuning.....	3-3	(2) Characteristic Impedance.....	3-11
(3) Heat Dissipation.....	3-5	(3) Type of Tuning.....	3-11
(4) Power Output.....	3-5	(4) Power Requirements ....	3-11
(5) Characteristic Impedance .....	3-5	(5) Maximum RF Input Power.....	3-13
(6) Weight.....	3-5	d. Installation.....	3-13
(7) Standard Navy Stock Number.....	3-5	4. Antenna Coupler	
(8) Specifications .....	3-5	CU-284/UR.....	3-13
(9) BuShips Drawing.....	3-5	a. General Description.....	3-13
d. Installation.....	3-5	b. Reference Data.....	3-13
(1) General.....	3-5	(1) Weight.....	3-13
(2) Mounting Brackets.....	3-6	(2) Frequency Range.....	3-13
(3) Arrangement of Coaxial Fittings.....	3-6	(3) Output Impedance.....	3-13
(4) Assembly of Mounting Brackets.....	3-6	(4) Type of Tuning.....	3-13
(5) Field Changes in the TDZ Transmitter.....	3-7	(5) Maximum RF Input Power.....	3-13
(6) Typical Installation.....	3-7	(6) Power Requirements ....	3-13
2. Antenna Coupler		(7) Instruction Book.....	3-13
CU-332A/UR.....	3-8	c. Installation.....	3-13
a. General Description.....	3-8	5. Antenna Coupler	
b. Main Components.....	3-8	CU-355/UR.....	3-15
c. Reference Data.....	3-8	a. General Description.....	3-15
(1) Frequency Range.....	3-8	b. Main Components.....	3-15
(2) Power Requirements ....	3-8	c. Reference Data.....	3-15
(3) Power Output.....	3-8	(1) Frequency Range.....	3-15
(4) Characteristic Impedance .....	3-8	(2) Characteristic Impedance.....	3-15
(5) Overall Dimensions.....	3-8	(3) Type of Tuning.....	3-15
		(4) Power Requirements ....	3-15
		(5) Maximum RF Input Power.....	3-15
		d. Installation.....	3-15

SECTION 32 . VHF/UHF  
MULTICOUPLERS (cont'd)

SECTION 34 . FILTER TYPE  
MULTICOUPLERS (cont'd)

Paragraph	Page
6. Antenna Coupler	
CU-377/UR.....	3-17
a. General Description.....	3-17
b. Reference Data.....	3-17
(1) Weight.....	3-17
(2) Frequency Range.....	3-17
(3) Output Impedance.....	3-17
(4) Type of Tuning.....	3-17
(5) Power Requirements...	3-17
(6) Instruction Book.....	3-17
c. Installation.....	3-17

SECTION 3-3. HF  
MULTICOUPLERS

1. General Description.....	3-19
2. Main Components.....	3-19
3. Reference Data.....	3-21
a. Frequency Range.....	3-21
b. Power Requirements.....	3-21
c. Power Handling Capa- bility.....	3-21
d. Characteristic Impedance.....	3-21
4. Installation.....	3-21

SECTION 3-4. FILTER TYPE  
MULTICOUPLERS

1. Receiving Filter Assembly AN/SRA-9A.....	3-23
a. General Description.....	3-23
b. Main Components.....	3-23
(1) Filter Assembly, Elec- trical F-145/SRA-9.....	3-25
(2) Test Set, Filter TS-734/SRA-9.....	3-25
(3) Case, Filter CY-1129A/SRA-9.....	3-25
(4) Case, Filter CY-1325/SRA-9A.....	3-25
(5) Dummy, Connector Plugs.....	3-25
c. Reference Data.....	3-25
(1) Frequency Range.....	3-25
(2) Primary Power Re- quirements.....	3-25
(3) Characteristic Impedance.....	3-25
(4) Power Handling Capa- bility.....	3-25

Paragraph	Page
(5) Controls.....	3-25
(6) Interchangeability.....	3-26
(7) Instruction Book.....	3-26
d. Installation.....	3-26
(1) Filter Subassembly Selection.....	3-26
(2) Filter Subassembly Installation.....	3-26
(3) Installation of the Complete Unit.....	3-27
e. Operation.....	3-27
(1) Channel Selection.....	3-27
(2) Output Jack Selection...	3-27
2. Receiving Filter Assembly AN/SRA-12.....	3-29
a. General Description.....	3-29
b. Main Components.....	3-29
(1) Electrical Filter Assembly AN/SRA-12....	3-29
(2) Filter Panel SB-404/SRA-12.....	3-29
(3) Filter Subassemblies....	3-31
(4) Shorting Plugs.....	3-31
c. Reference Data.....	3-31
(1) Frequency Range.....	3-31
(2) Primary Power Re- quirements.....	3-31
(3) Characteristic Impedance.....	3-31
(4) Power Handling Capa- bilities.....	3-31
(5) Controls.....	3-31
(6) Interchangeability.....	3-31
(7) Instruction Book.....	3-31
3. Transmitting Filter Assemblies.....	3-33
a. General Description.....	3-33
b. Main Components.....	3-33
c. Reference Data.....	3-33
(1) Frequency Range.....	3-33
(2) Primary Power Re- quirements.....	3-33
(3) Power Handling Capa- bility.....	3-33
(4) Characteristic Impedance.....	3-33
(5) Controls.....	3-33
(6) Interchangeability.....	3-33
d. Installation.....	3-35
(1) General.....	3-35
(2) Mounting the Cabinets...	3-35



SECTION 3-4. FILTER TYPE  
MULTICOUPLERS (cont'd)

Paragraph	Page
(a) One Cabinet Installation.....	3-35
(b) Stacking Two Cabinets.....	3-37
(c) Stacking Three Cabinets.....	3-37
(3) Filter Assembly Selection.....	3-37
e. Operation.....	3-37

SECTION 3-5. INSTALLATION OF  
AUXILIARY EQUIPMENT

1. Three-Inch Coax Line.....	3-39
a. General.....	3-39
b. Characteristics.....	3-39
(1) Characteristic Impedance.....	3-39
(2) Outside Diameter.....	3-39
(3) Inside Diameter.....	3-44
(4) Inner Conductor.....	3-44
(5) Spacing Teflon Beads.....	3-44

SECTION 3-5. INSTALLATION OF  
AUXILIARY EQUIPMENT (cont'd)

Paragraph	Page
c. Installation.....	3-44
2. Antennas.....	3-44
a. General.....	<del>3-44</del>
b. Sleeve Antennas.....	<del>3-44</del>
c. UHF Antennas.....	3-47
d. Modified Whip Antenna.....	3-47
e. Miniature Receiving Antenna AN/SRA-10(XG-1).....	3-48

SECTION 3-6. RECENTLY (1952) DE-  
SIGNER RADIO ANTENNA SYSTEMS

1. General.....	3-51
2. Multicoupler System on the DL-2.....	3-53
3. Multicoupler System on the CLC-1.....	3-53
a. Radio Transmitting System.....	3-53
b. Radio Receiving System.....	3-53
c. UHF System.....	3-53

LIST OF ILLUSTRATIONS

SECTION 3-2. VHF/UHF  
MULTICOUPLERS

Figure	Page
3-1 Group of Six Type CU-225/UR Antenna Couplers.....	3-2
3-2 Perspective View of CU-225/UR Antenna Coupler.....	3-4
3-3 Mounting Dimensions for CU-255/UR.....	3-5
3-4 Typical TDZ/RDZ Installation.....	3-7
3-5 Manual Drive Mechanism.....	3-8
3-6 Typical TED-AN/URR-13 Installation.....	3-9
3-7 Antenna Coupler CU-274/UR.....	3-10

SECTION 3-2. VHF/UHF  
MULTICOUPLERS (Cont'd)

Figure	Page
3-8 Antenna Coupler CU-284/UR.....	3-12
3-9 Antenna Coupler CU-355 (XN-1)/UR.....	3-14
3-10 Antenna Coupler CU-377/UR.....	3-16

SECTION 3-3. HF MULTICOUPLERS

3- Antenna Coupler AN/SRA-15.....	3-18
3-12 HF Antenna Multicoupler Installation Dimensions.....	3-20

SECTION 3-4. FILTER TYPE  
MULTICOUPLERS

Figure		Page
3-13	Filter Assembly Electrical AN/SRA-9A.....	3-22
3-14	Filter Assembly Electrical F-145/SRA-9.....	3-24
3-15	Filter Assembly Electric AN/SRA-12.....	3-28
3-16	Filter Assembly Electric AN/SRA-12.....	3-30
3-17	Filter Assembly Electric F-159/SRT.....	3-32
3-18	Two Cabinet Installation ...	3-34
3-19	Typical Filter Assembly Installation.....	3-36

SECTION 3-5. INSTALLATION OF  
AUXILIARY EQUIPMENT

3-20	Flange Assembly Waveguide Type UG-1087/U.....	3-40
3-21	Bulkhead Flange, MX-1599/U.....	3-40
3-22	3-1/8-175 Ohm End Seal Type MX-1598/U.....	3-41
3-23	Inner Conductor Connector, Type MX-1600/U.....	3-41
9-24	3-1/8-175 Ohm 45° and 90° Bends, Line Section, Types CG-1176/U and CG-1177/U.....	3-42
3-25	Assembly of RG-162/U Coaxial Transmission Line.....	3-43

SECTION 3-5. INSTALLATION OF  
AUXILIARY EQUIPMENT (cont'd)

Figure		Page
3-26	Sleeve Antennas De- signed for the CLC-1..	3-45
3-27	Broad-band UHF Antennas..	3-46
3-28	RF Choke Box for TCS Whip Antenna.....	3-48
3-29	Minature Receiving Antenna AN/SRA-10(XG-1).....	3-49

SECTION 3-6. RECENTLY (1952) DE-  
SIGNER RADIO ANTENNA SYSTEMS

3-30	Interconnecting Diagram for Multicoupling System on DL-2..	3-52
3-31	Antenna System, CLC-1- Radio Transmitting Room No. 1.....	3-54
3-32	Antenna System, CLC-1- Radio Transmitting Room No. 2.....	3-55
3-33	Antenna System, CLC-1- Radio Central..	3-56
3-34	Antenna System, CLC-1- Teletype Room..	3-57
3-35	Antenna System, CLC-1- UHF Room No. 1.....	3-58
3-36	Antenna System, CLC-1- UHF Room No. 2.....	3-59
3-37	Antenna System, CLC-1- UHF Room No. 3.....	3-60

LIST OF TABLES

SECTION 3-1. INTRODUCTION		SECTION 3-4. FILTER TYPE MULTICOUPLERS	
Table	Page	Table	Page
3-i	Types of Multicouplers..... 3-1	3-5	Equipment Supplied with AN/SRA-9A..... 3-23
		3-6	Filter Subassemblies Supplied with AN/SRA-9A..... 3-26
		3-7	Equipment Supplied with AN/SRA-12..... 3-29
		3-8	Filter Subassemblies Supplied with AN/SRA-12..... 3-31
		3-9	Equipment Supplied with Transmitting Filter Assemblies..... 3-35
		3-10	Frequency Coverage Chart for Filter Assemblies.. 3-38
SECTION 3-2. VHF/UHF MULTICOUPLERS		SECTION 3-5. INSTALLATION OF AUXILIARY EQUIPMENT	
3-2	Equipment Supplied with Antenna Coupler CU-274/UR.....3-11	3-11	Equipment Supplied with AN/SRA-10(XG-1)..... 3-50
3-3	Equipment Supplied with Antenna Coupler CU-355/UR.....3-15		
SECTION 3-3. HF MULTICOUPLERS			
3-4	High Frequency Multicouplers.....3-19		

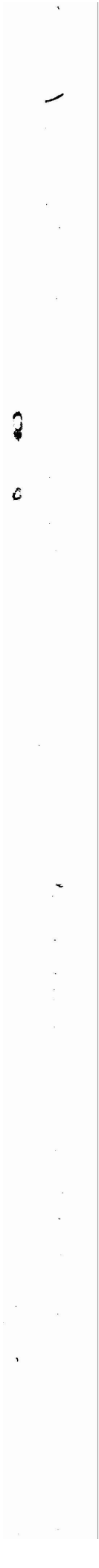

SECTION 3-1

INTRODUCTION

1. GENERAL.

With the increasing number of communications equipment required aboard Naval vessels, the problem has arisen of finding suitable locations for additional antennas in ship super structures that are already crowded with various types of antennas. One approach to this problem is the use of multicoupler systems which permit the simultaneous operation of a number of transmitters and/or receivers into a single antenna. In this manner the number of antennas can be reduced without sacrificing any of the required communications channels. This not only permits maximum use of the best available antenna locations but also reduces inter'coupling with its attendant adverse effects upon antenna patterns and operation.

2. TYPES OF MULTICOUPLERS.

Various types of multicouplers have been designed to cover different frequency ranges to operate with either receivers or transmitters or both. This chapter will not discuss all of these multicouplers since some of them are still in the development stage or are in the process of being evaluated.

The multicouplers covered in this chapter are those that are currently being installed on Naval vessels. A list of these multicouplers, their frequency ranges and number of channels are given below in Table 3-1. Much of the material in this chapter is Preliminary and therefore, subject to later changes. This should be considered when using any of this material for installation planning.

TABLE 3-1. TYPES OF MULTICOUPLERS

Type of Multicoupler	Frequency Range	No. of Channels	Operates With		Page
			Receivers	Transmitters	
CU-255/UR	230-390 mc	2-6	X	X	3-3
CU-332/UR	230-390 mc	2-6	X	X	3-8
CU-274/UR	225-400 mc	4	X	X	3-11
CU-284/UR	225-400 mc	2	X	X	3-13
CU-355/UR	225-400 mc	4	X	X	3-15
CU-377/UR	225-400 mc	2	X	X	3-17
HF Multicouplers	2-26mc	4	X	X	3-19
AN/SRA-9	14 kc - 32 mc	7	X		3-23
AN/SRA-12	14 kc - 32 mc	7	X		3-29
Transmitting Filter Assemblies	175 kc - 18.1 mc	2-4		X	3-33

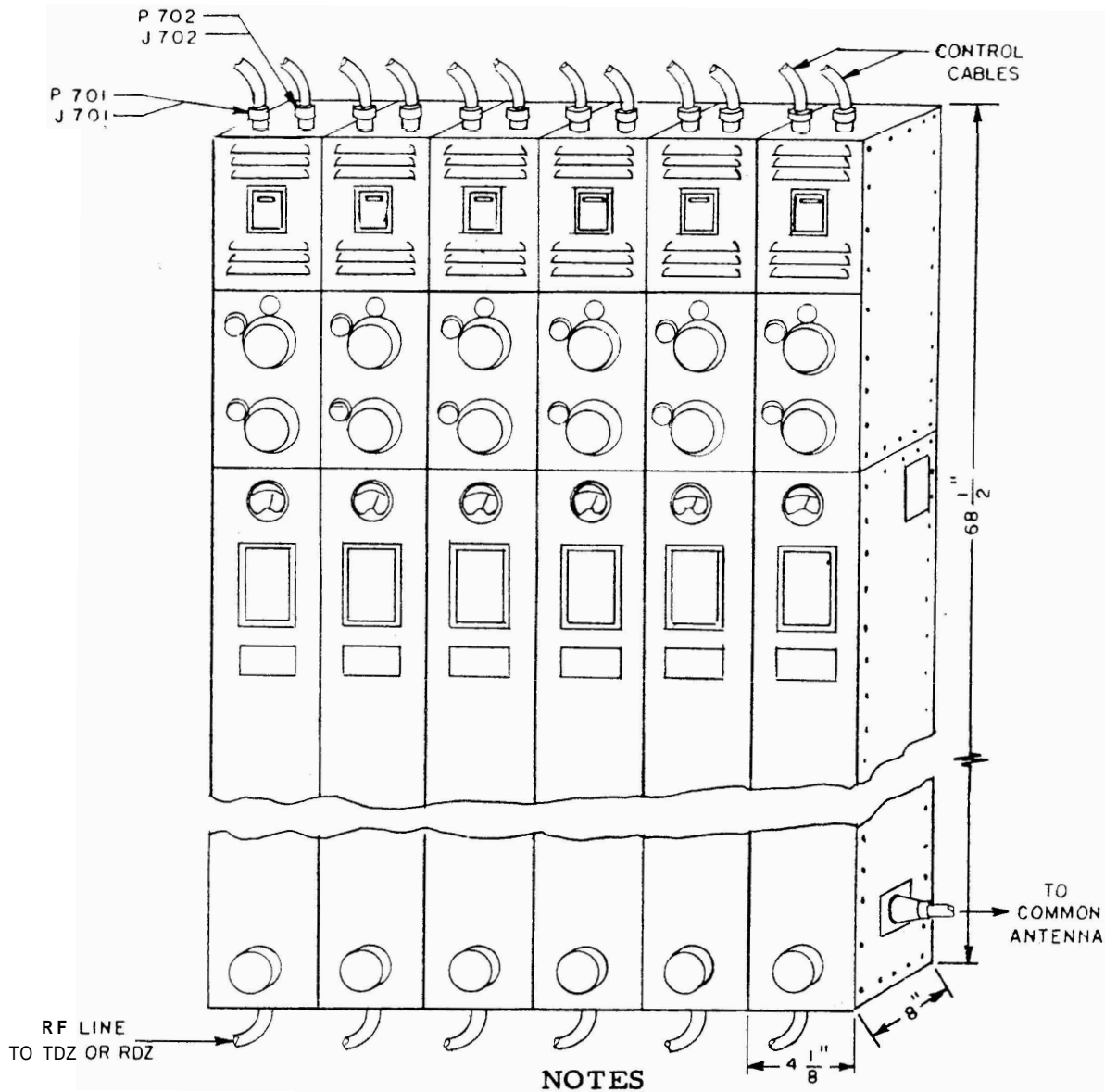

1. When used with the TDZ transmitter only, connect the control cable to 5701. 5702 is not used.
2. When used with the RDZ receiver only, connect RDZ to J702 and Selector Control Unit Type 23497 to 5701.
3. When used with TDZ-RDZ combination, connect TDZ to 5701 and connect RDZ to 5702. Selector Control Unit Type 23497 is not required.
- 4.

Connector	Type
J701	AN-3102-22-14P
P701	AN-3108-22-14S
5702	AN-3102-22-14S
P702	AN-3108-22-14P

Figure 3-1. Group of Six Type CU-255/UR Antenna Couplers

SECTION 3-2

VHF/UHF MULTICOUPLERS

1. ANTENNA COUPLER CU-255/UR.

a. GENERAL DESCRIPTION. — The CU-255/UR Antenna Coupler equipments, when assembled into a group of two to six units, provide a system for operating two to six UHF transmitters (and/or receivers) into a single antenna. One coupler unit is required for each transmitter or receiver, or transmitter-receiver combination (see Figure 3-1).

This equipment was designed for operation with the Model TDZ transmitter and Model RDZ receiver. Hence the frequency range is 230 to 390 mc.

These couplers can be tuned manually to any frequency in this range. When used with the TDZ/RDZ equipment, they may be tuned automatically to any one of 10 preset channels in this band by dialing the desired channel locally on the TDZ or on a remote channel selector.

b. MAIN COMPONENTS. — The CU-255/UR Antenna Coupler consists of two major components: the coupling cavity or RF section, and the automatic drive mechanism (see Figure 3-2).

The RF section is essentially an impedance matching device. It is capable of transforming antenna loads with mismatches up to 2.5 to 1 so as to give 50 ohms resistance at the RF feedline terminal. This results in maximum power transfer to or from the antenna system.

Correct adjustment of the tuning controls is indicated by the meter on the front panel of the unit which measures the output from a reflectometer, a device indicating the magnitude of the power reflected back from the coupling circuit. When the controls are adjusted so that the tuning indicator reads zero, there is no reflected power and the system

impedances are matched. For a more complete discussion of this unit refer to the instruction book for Antenna Coupler CU-255/UR.

The drive mechanism permits manual and automatic tuning of the coupler and fits into the top of the RF section to form a long thin unit. It may be removed as a unit for servicing when necessary.

The framework of the coupler is constructed of steel angles and aluminum alloy castings. The entire unit is enclosed by aluminum alloy covers which also provide an RF shield around the coupling cavity. These covers are secured in place with screws and may be removed to make all parts accessible. The reflectometer is accessible by removing its protective cover. Mounting brackets are supplied to provide shock mounting for the units when they are assembled in a group.

The inherent insertion loss in any one unit over the frequency range is about 1 db. For a 15 mc channel separation, the minimum power isolation between channels is normally about 20 db, or comparable to the isolation realized in a well-designed UHF shipboard antenna installation.

c. REFERENCE DATA.

(1) FREQUENCY RANGE:

230 to 390 mc normally  
227 to 396 mc maximum

(2) POWER REQUIRED FOR AUTOMATIC TUNING:

115 volts AC, 50/60 cycles, single phase, 75 to 200 watts (this power is derived from TDZ transmitter or NT-23497 selector control unit).

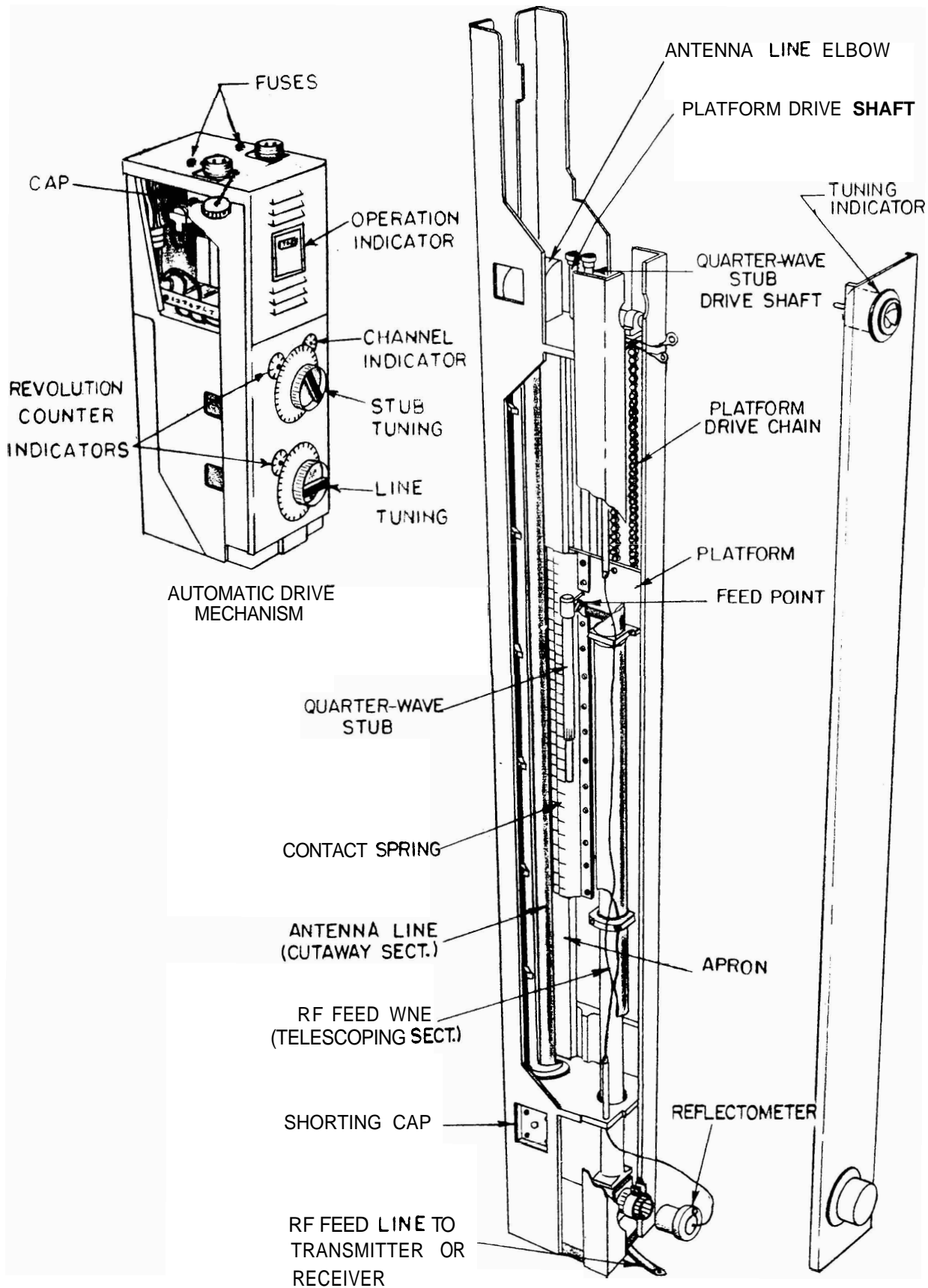

Figure 3-2. Perspective View of CU-255/UR Antenna Coupler



48 volts DC, 0.35 amps or 42 watts maximum (this power is derived from TDZ transmitter and is required during tuning cycle only).

(3) HEAT DISSIPATION:  
Normally negligible

(4) POWER OUTPUT:  
Can be used with transmitters with outputs up to 100 watts.

(5) CHARACTERISTIC IMPEDANCE:  
50 ohms

(6) WEIGHT: 90.1 pounds

(7) STANDARD NAVY STOCK NUMBER: F16-C-91733-5481

(8) SPECIFICATIONS:  
MIL-A-15706 (Ships)  
BuShips Spec. Ships-A-488

(9) BUSHIPS DRAWING:  
RE 66D 2011E, CU-255/UR Antenna Coupler dimensions and interconnections.

d. INSTALLATION.

(1) GENERAL. - The CU-255/UR Antenna Coupler is designed to be mounted vertically on a bulkhead or other solid support (see Figure 3-3). On small ships, space limitations may dictate other arrangements. In such cases the couplers may be mounted horizontally overhead.

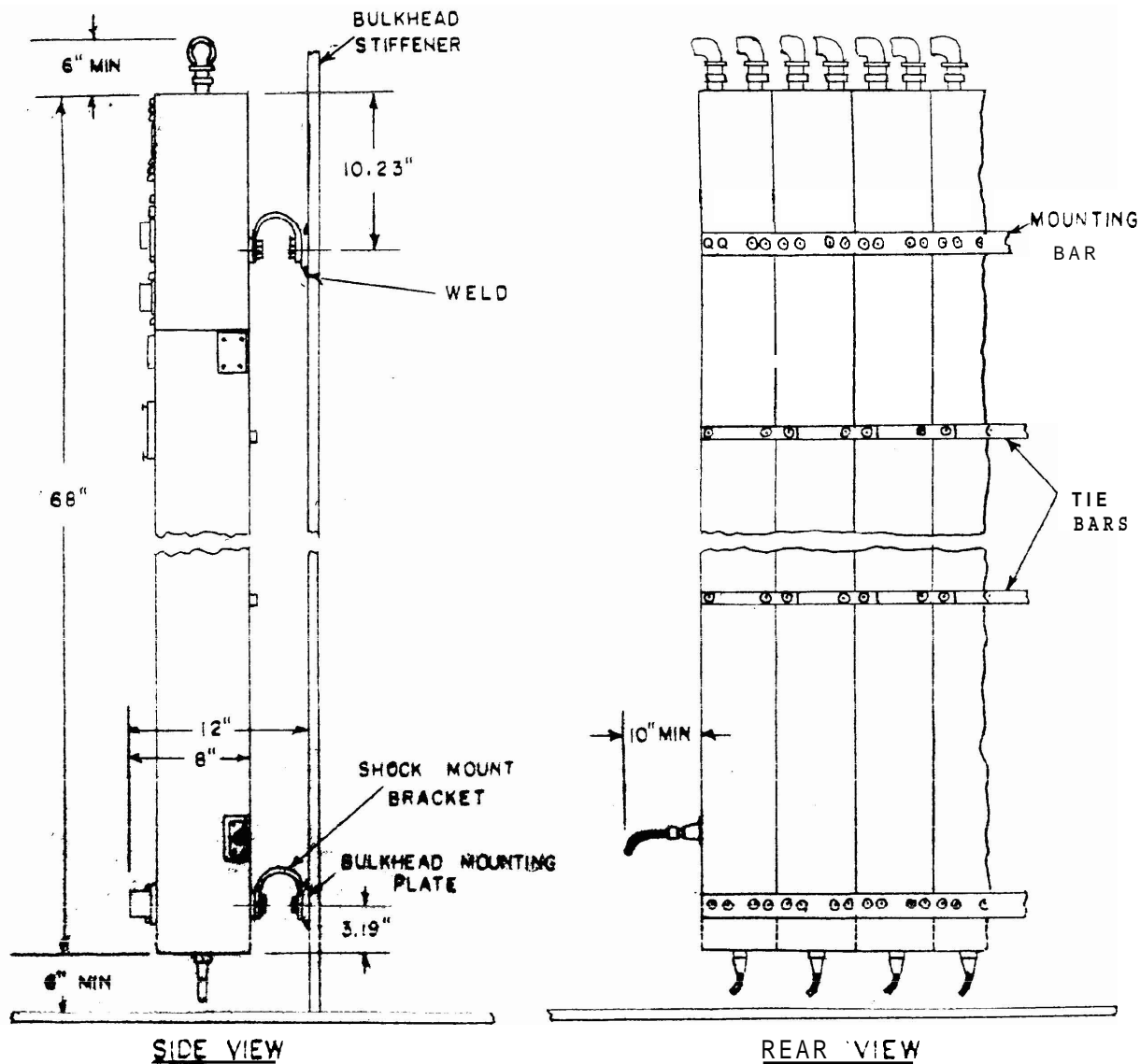

Figur 3-3. Mounting Dimensions for CU-255/UR

This is an inconvenient position from a standpoint of tuning the equipments and should be used only when absolutely necessary. Special mounting brackets are required for this type of installation.

(2) MOUNTING BRACKETS. - The mounting-bracket parts supplied with each unit consists of two U-shaped shock mounts. Two mounting bars long enough to accommodate six units and a set of 12 tie bars are supplied in Installation Kit MK-114/UR. Two other bulkhead mounting plates are to be supplied by the installing activity. They are to be made from 1/2" cold rolled steel, 2-1/2" wide and long enough to span the group of couplers.

(3) ARRANGEMENT OF COAXIAL FITTINGS. - As received from the factory the special coaxial connectors in the units for joining the sections of the common antenna line may not be properly arranged. To form a four-unit group for example, these connectors should be as follows when viewing the unit from the front:

Lower left side of unit No. 1 (numbering left to right): No flange extension on inner or outer conductor elbow; the antenna line short-circuiting cap (supplied in Installation Kit MK-114/UR) and insulator fit over the threaded end of the inner conductor elbow and into a recess in the outer conductor elbow. A nut then screws onto the inner conductor extending thru the fitting and four screws secure the fitting to the outer conductor elbow. This assembly becomes the starting point of the common antenna line.

Upper right side of units No. 1 and 3 and lower right side of units No. 2 and 4: Flange extension of outer conductor elbow and inner conductor elbow extension should be male type fittings.

Upper left side of units No. 2 and 4, and lower left side of unit No. 3: Flange extension of outer conductor elbow and inner conductor elbow extension should be female type fittings.

The tapered adapter supplied with the Installation Kit MK-114/UR attaches at the lower right side of unit No. 4 and becomes the antenna line terminal. This adapter consists of an inner conductor,

a small insulator, and an outer conductor which plugs into the elbow extension and is secured to the frame of the coupler unit by four screws. The inner conductor plugs into its elbow extension and is held in place by the outer conductor and the small insulator. The adapter takes a standard Type "N" fitting such as UG-941A/U and UG-982/U.

If, after laying the coupler units out side by side on a deck (face up), they cannot be arranged so that the elbow fittings conform to the above sequence, proceed as follows: Remove the four screws securing the outer conductor elbow to the top or bottom casting in the unit and turn the elbow (including the inner conductor) around 180° then replace the screws. Make sure that there is an insulator at the flange in each elbow.

(4) ASSEMBLY OF MOUNTING BRACKETS. - When the above procedure is completed, turn the units face downward across a pair of wooden blocks (pad to prevent marring front panel of the units), reversing the previous order; that is, counting left to right, place No. 1 unit in position 4, No. 2 in position 3 and so on. For a four-unit group, secure four of the U-shaped shock mounts to each of the two mounting bars. Line up the coaxial connectors and push the coupler units together, engaging the antenna line fittings. There will be about 1/16" space between the units when the fittings are properly seated. Secure the two mounting bars to the back of the group (one near the top and one near the bottom). Install the tie straps (part of the Installation Kit) as shown in Figure 3-3. Raise the group of units to a vertical position and rest them on a 6 to 10-inch block. Mark the location on the bulkhead opposite the shock mounts where the bulkhead mounting plates are to be welded. Drill and tap these mounting plates for 3/8"-24 bolts, spotting the holes from the holes in the shock mount brackets. Bolt the mounting plates temporarily to the shock mounts and tack weld the plates to the bulkhead. Remove the bolts securing the shock mounts to the mounting plates and set the units aside. Complete the weld on the mounting plates, and then secure the units to the

mounting plates. This completes the mounting details.

(5) FIELD CHANGES IN THE TDZ TRANSMITTER. - Certain wiring modifications and additions in the TDZ transmitter are necessary in order to control the CU-255/UR coupler automatically. These changes are shown in the Bureau

of Ships interconnection wiring diagram (RE 66D 2011E) and are described completely in the Field Change Bulletin for Field Change #7 (Stock No. F16-M-384502-218).

(6) TYPICAL INSTALLATION. - Figure 3-4 shows a block diagram of a typical shipboard TDZ/RDZ installation using the CU-255/UR Antenna Couplers.

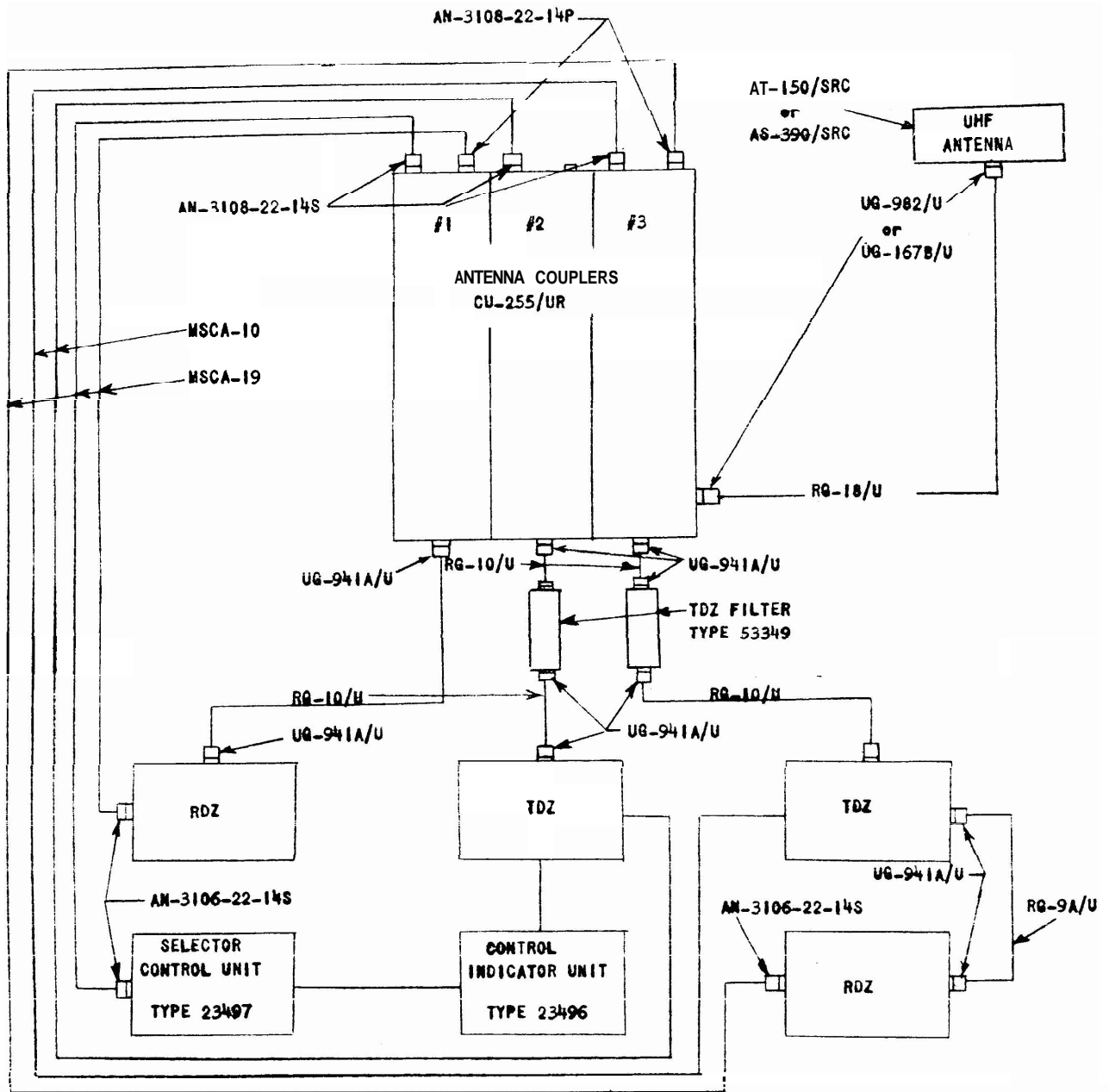

Figure 3-4. Typical TDZ-RDZ Installation

2. ANTENNA COUPLER CU-332A/UR.

a. GENERAL DESCRIPTION. — The CU-332A/UR Antenna Coupler equipments when assembled into a group of two to six units provide a system for operating two to six UHF communication circuits into a single antenna. One coupler unit is required for each transmitter or receiver, or transmitter-receiver combination.

Antenna Coupler CU-332A/UR is identical to Antenna Coupler CU-255/UR except for the drive mechanism. The drive mechanism for the CU-255/UR provides manual and automatic tuning of the coupler; whereas the drive mechanism for the CU-332A/UR provides for manual tuning only. These drive mechanisms are interchangeable on the RF section of the couplers.

The CU-332A/UR coupler is used with manually-tuned UHF equipment such as the Model TEE transmitter and the AN/URR-13 receiver, any other manually-tuned equipment operating in the 230 to 390 mc frequency range.

b. MAIN COMPONENTS. — Antenna Coupler CU-332A/UR consists of two major components; the coupling cavity or RF section, and the manual drive mechanism (see Figure 3-5).

For a brief description of the RF section refer to the preceding material on Antenna Coupler CU-255/UR. The tun-

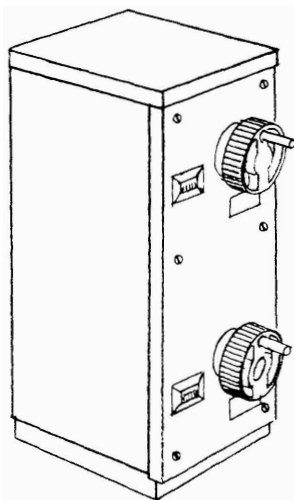

Figure 3-5. Manual Drive Mechanism

ing mechanism fits into the top of the RF section. There are two tuning knobs and two counter dials on the drive mechanism. One knob adjusts the length of the quarter-wave coupler and the other knob adjusts its position with respect to the cutaway section of the antenna line.

For a complete description of these units refer to the Instruction Book for Antenna Coupler CU-332A/UR, NavShips 91745.

c. REFERENCE DATA.

(1) FREQUENCY RANGE:

230 to 390 mc normal  
227 to 396 mc maximum

(2) POWER REQUIREMENTS:

No AC or DC power is required for operation of this equipment.

(3) POWER OUTPUT:

Can be used with transmitters with outputs up to 100 watts.

(4) CHARACTERISTIC IMPEDANCE:

50 ohms

(5) OVERALL DIMENSIONS:

Height 62-1/2"  
Width 4-3/4"  
Depth 8-5/16"

(6) WEIGHT: 79.9 pounds

(7) STANDARD NAVY STOCK NUMBER: F16-C-91733-5601

d. INSTALLATION. — Antenna Coupler CU-332A/UR is normally installed vertically on a bulkhead. It is secured to the mounting surface by means of cap screws or bolts in the mounting bars attached to U-shaped shock mount brackets. Where space limitations require it, the coupler can be mounted horizontally on the overhead; however, this is generally undesirable.

The installation information for the CU-255/UR in the preceding section applies to this coupler also, since the couplers are similar.

Figure 3-6 shows a block diagram of a typical TED-AN/URR-13 installation using the CU-332A/UR Antenna Couplers.

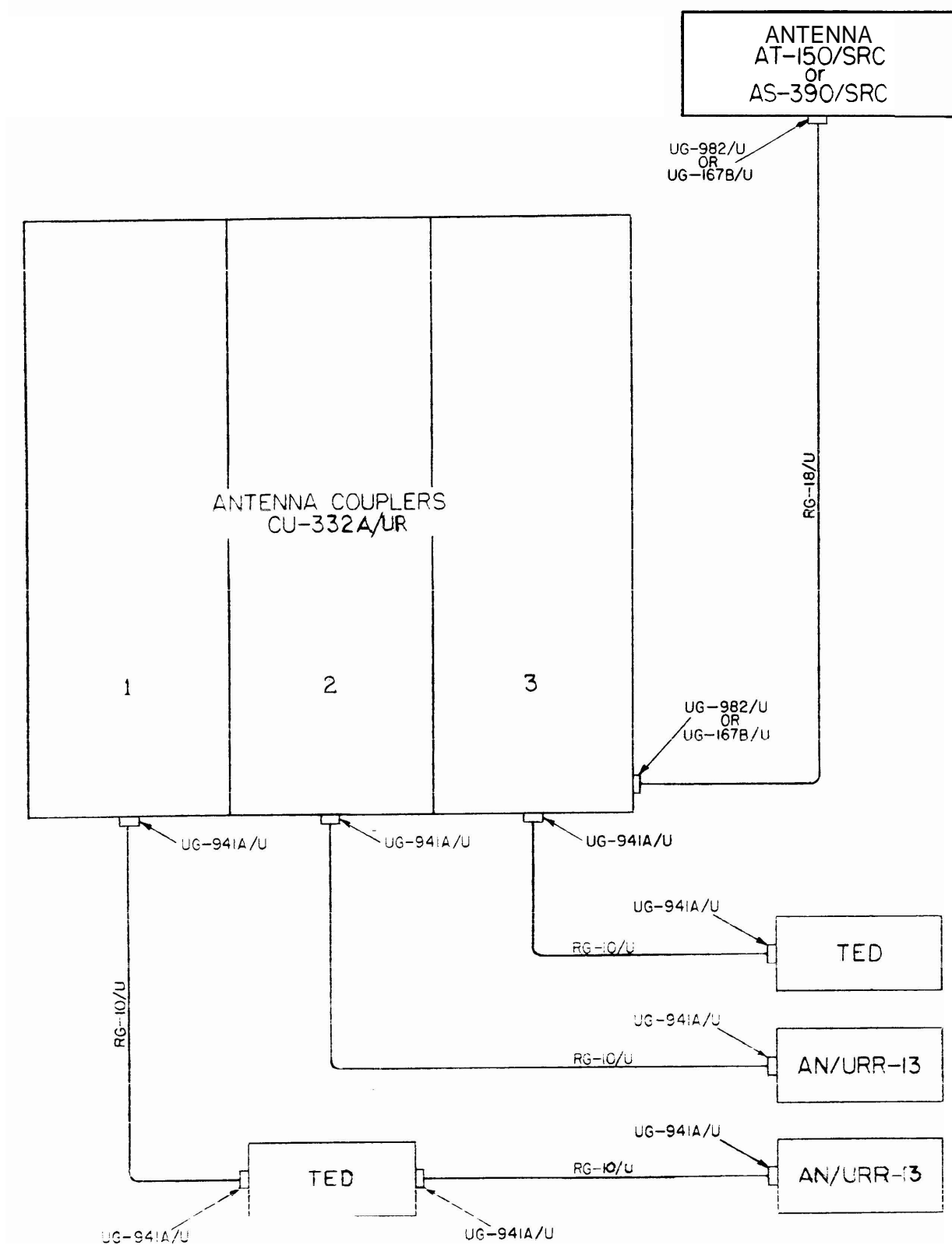

Figure 3-6. Typical TED-AN/URR-13 Installation

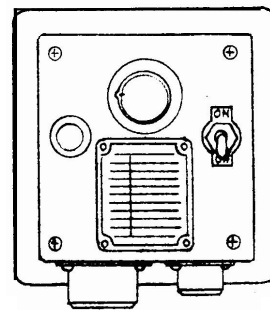
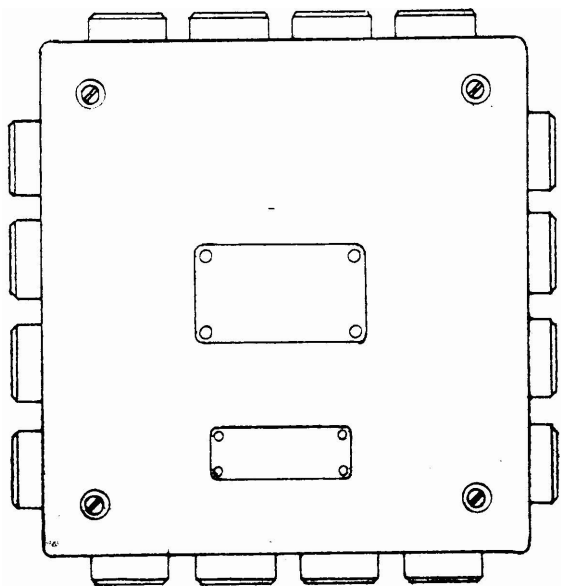
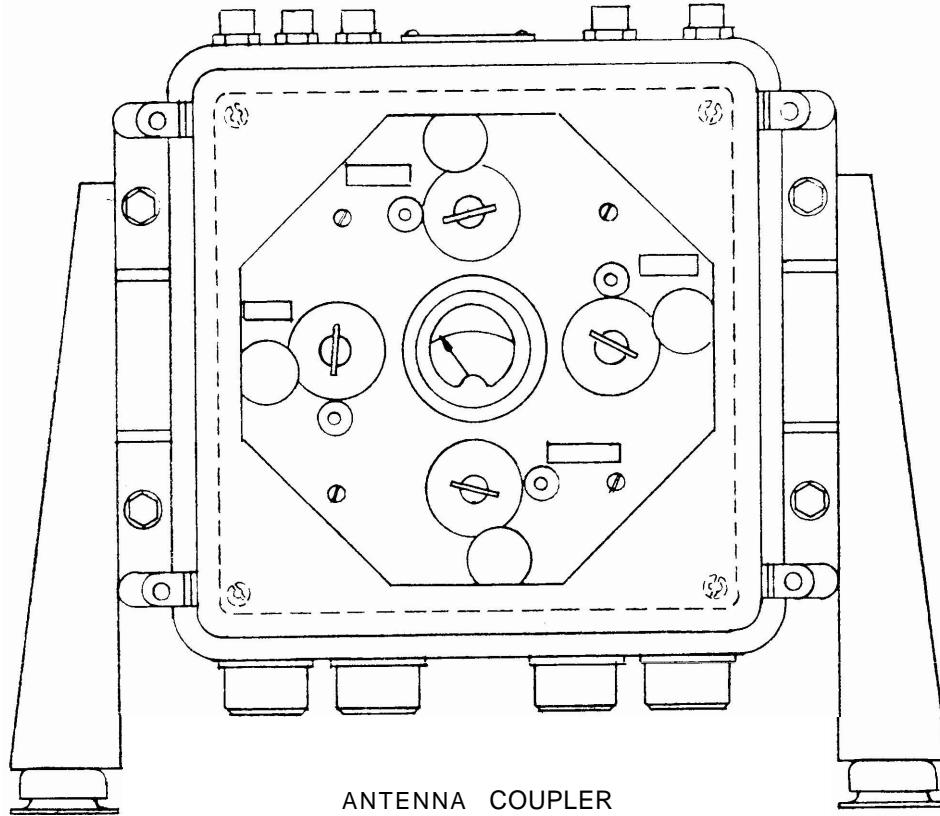

Figure 3-7. Antenna Coupler CU-274/UR

3. ANTENNA COUPLER CU-274/UR.

a. GENERAL DESCRIPTION. — Antenna Coupler CU-274/UR provides for the simultaneous operation of four UHF transmitters or receivers into a single antenna in the frequency range of 225 to 400 megacycles (see Figure 3-7).

The coupler has four cavities which are independently tuned either automatically or manually. For automatic tuning each cavity must first be pre-tuned to 10 corresponding frequency channels in the frequency range of the attached receiver or transmitter, and thereafter it is automatically retuned by an autotune mechanism. Manual tuning of each cavity is possible when the clutch release knob is loosened.

Antenna Coupler CU-274/UR was designed primarily for use with the TDZ transmitter and RDZ receiver, but it may be used with other UHF equipments such as the TED and AN/URR-13.

b. MAIN COMPONENTS. — The equipment that is supplied with Antenna Coupler CU-274/UR is listed in Table 3-2.

Antenna Coupler CU-274/UR consists of four identical coaxial resonators mounted in a frame along with their associated autotune mechanisms. A meter on the coupler indicates maximum transfer of energy when any channel is properly tuned to the transmitting frequency.

There is no meter indication when tuning a channel for receiving. The autotune dials on top of the coupler bear an approximate frequency calibration. The coupler is completely shielded and produces no RF interference.

Selector Control C-1219/UR has a 10-position switch for selecting any one of the 10 pre-selected frequency channels of any single cavity autotune mechanism of the coupler. It also has a pilot lamp and a power "ON-OFF" switch.

Terminal Box J-493/UR contains four bakelite barrier-type terminal boards. It permits the interconnection of four RDZ (or similar) receivers and their Remote Channel Selectors through the Antenna Coupler CU-274/UR. (Transmitters are connected directly to the coupler.)

c. REFERENCE DATA.

- (1) FREQUENCY RANGE:  
225 to 400 mc
- (2) CHARACTERISTIC IMPEDANCE:  
50 ohms
- (3) TYPE OF TUNING:  
Capacitively-tuned cavities
- (4) POWER REQUIREMENTS:  
115 volts AC, single phase, 60 cycles (for automatic tuning)

TABLE 3-2. EQUIPMENT SUPPLIED WITH ANTENNA COUPLER CU-274/UR

Unit	Type Designation	Qty.	Overall Dimensions (Inches)			Weight (lbs)
			Height	Width	Depth	
Antenna Coupler	CU-274/UR	1	14-7/16	15-1/8	11-7/8	57
Mounting Brackets		2	1 - 1	2 - 1	2 2-1/2	7
Selector Control	C-1219/UR	1	5-13/16	5-1/8	3-11/64	5
Terminal Box	J-493/UR	1	10-1/2	11	2-5/8	5-1/4
Mating Connectors: for CU-274/UR	UG-21B/U	5				
	AN-3106A-24-5S	4				
	AN-3057-16	4				
for J-493/UR	AN-3106A-24-5P	4				
	AN-3057-16	4				
	AN-3106A-22-14S	8				
	AN-3057-12	8				
for C-1219/UR	AN-3106A-24-5P	1				
	AN-3057-16	1				
	AN-3106A-14S-7S	1				
	AX-3057-6	1				

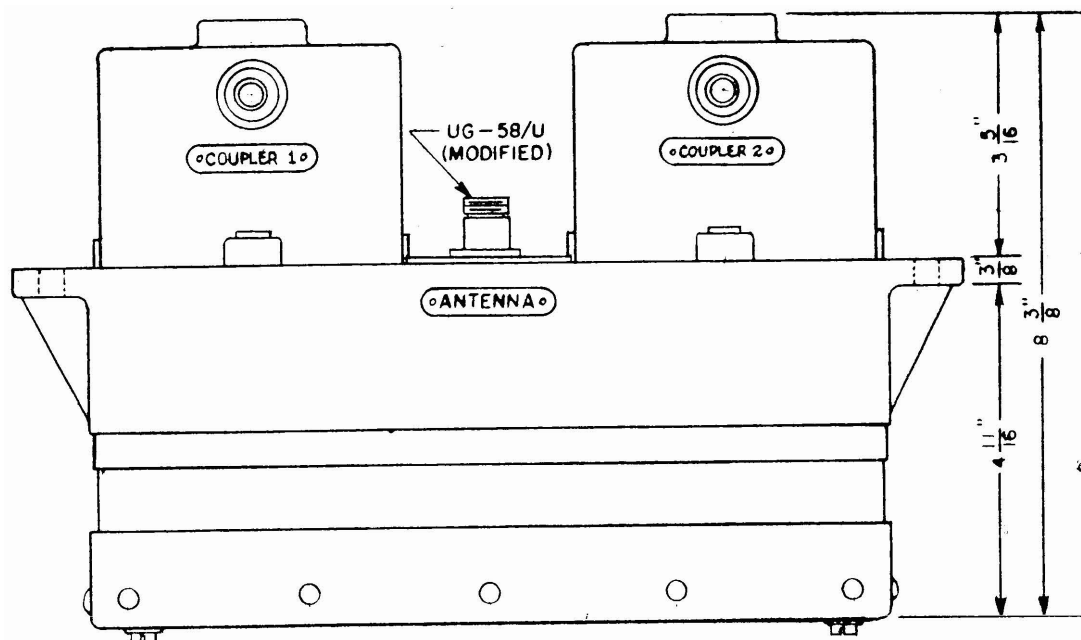

REAR VIEW

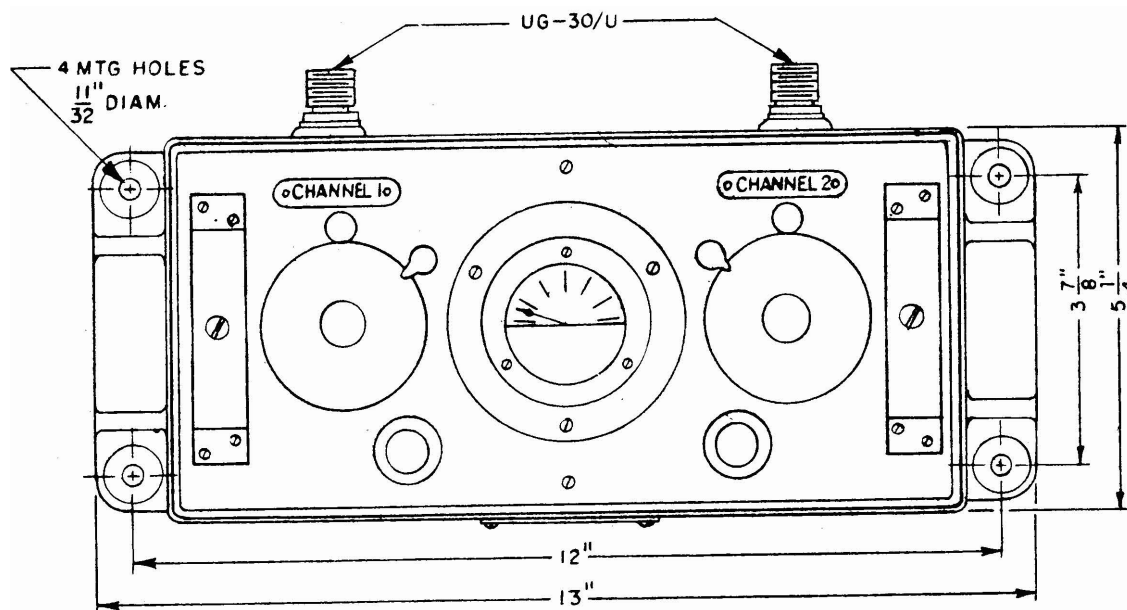

TOP VIEW  
(WITH COVER OFF)

Figure 3-8. Antenna Coupler CU-284/UR



(5) MAXIMUM RF INPUT POWER:  
100 watts

d. INSTALLATION. - Antenna Coupler CU-274/UR may be table or bulkhead mounted. Two mounting brackets with shock mounts are supplied for mounting the coupler.

The coupler has 5 Type "N" RF connectors: four input connectors and one antenna connector. There are also 4 Type "AN" connectors for the power and control cables. All the mating connectors required for cable connections to the units of this equipment are furnished with the equipment. Mounting bolts and external cables are not supplied.

There should be a minimum adjacent channel separation of 15 mc between operating frequencies of the four cavities of this coupler. When the frequencies must necessarily be close to each other, it is preferable to select frequencies in the low end of the band if possible. The adjacent channel attenuation characteristics of the coupler is better at low frequencies than it is at higher frequencies.

When this coupler is used for simultaneous transmitter and receiver operation, do not tune a receiver channel to the same frequency as a transmitter channel. This would result in damage to the receivers.

The CU-274/UR is used in submarine UHF installations because of its compact size. However, the CU-274/UR is not as efficient as the CU-255/UR or CU-332A/UR couplers; therefore, it should be installed only when it is not practicable to install one of the more efficient types of antenna couplers.

4. ANTENNA COUPLER CU-284/UR.

a. GENERAL DESCRIPTION. - Antenna Coupler CU-284/UR (see Figure 3-8) permits the simultaneous operation of two UHF transmitters or receivers into a single antenna in the frequency range of 225 to 400 mc. It is designed for installation in submarines and other small vessels primarily.

The coupler is tuned manually and consists of two capacitively-tuned resonant

cavities; each cavity has a 50-ohm terminal impedance. The output circuit is provided with a metering circuit for indication of proper tuning of the cavities.

This coupler is similar to Antenna Coupler CU-274/UR except that it can be tuned manually only and it accommodates two radio equipments instead of four.

The efficiency of the CU-284/UR antenna coupler is better than the efficiency of the CU-274/UR antenna coupler but it is less efficient than the CU-332A/UR or CU-255/UR antenna couplers.

Antenna Coupler CU-284/UR may be used with UHF equipments such as TDZ-RDZ and TED-AN/URR-13. However, if this coupler is installed in a system having quick-shift features (such as TDZ-RDZ), these features will be lost since the CU-284/UR must be manually tuned.

b. REFERENCE DATA.

(1) WEIGHT: 16 pounds

(2) FREQUENCY RANGE:  
225 to 400 mc

(3) OUTPUT IMPEDANCE:  
50 ohms

(4) TYPE OF TUNING:  
Manual tuning of capacitively-tuned cavities.

(5) MAXIMUM RF INPUT POWER:  
100 watts

(6) POWER REQUIREMENTS:  
None

(7) INSTRUCTION BOOK:  
NavShips 91790

c. INSTALLATION. - The CU-284/UR Antenna Coupler may be mounted on the bulkhead or on the overhead. It has a dust cover (held in place by two screws) which must be removed to gain access to the tuning dials.

There is a UG-30/U connector on the bottom of each cavity for connecting the transmission lines from the radio equipment. The 50-ohm antenna transmission line connects to a modified UG-58/U connector on the back of the coupler.

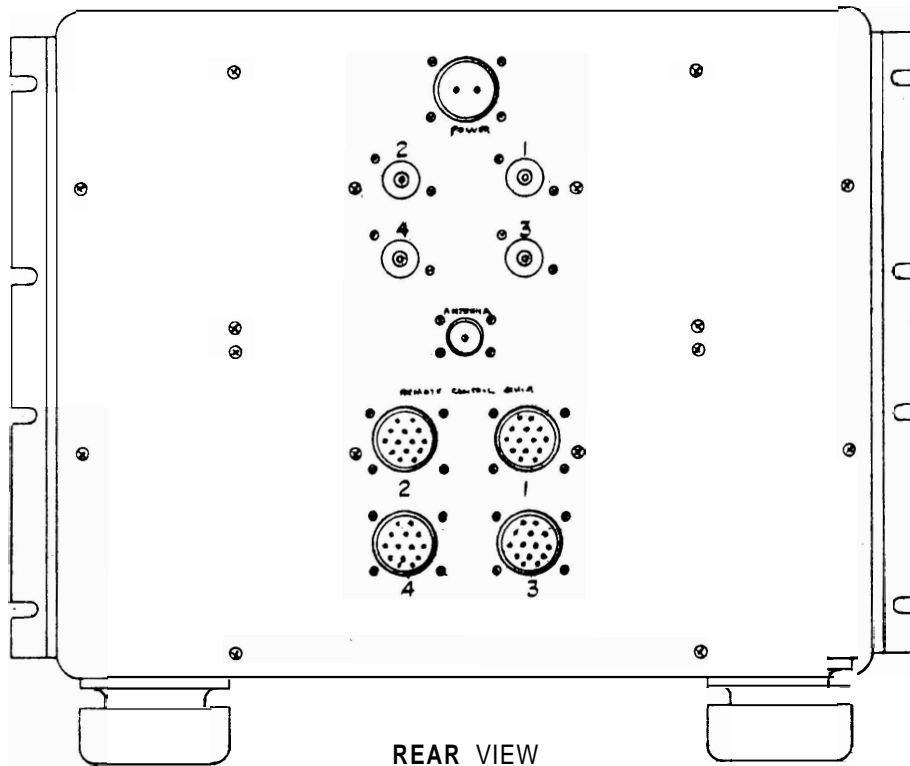
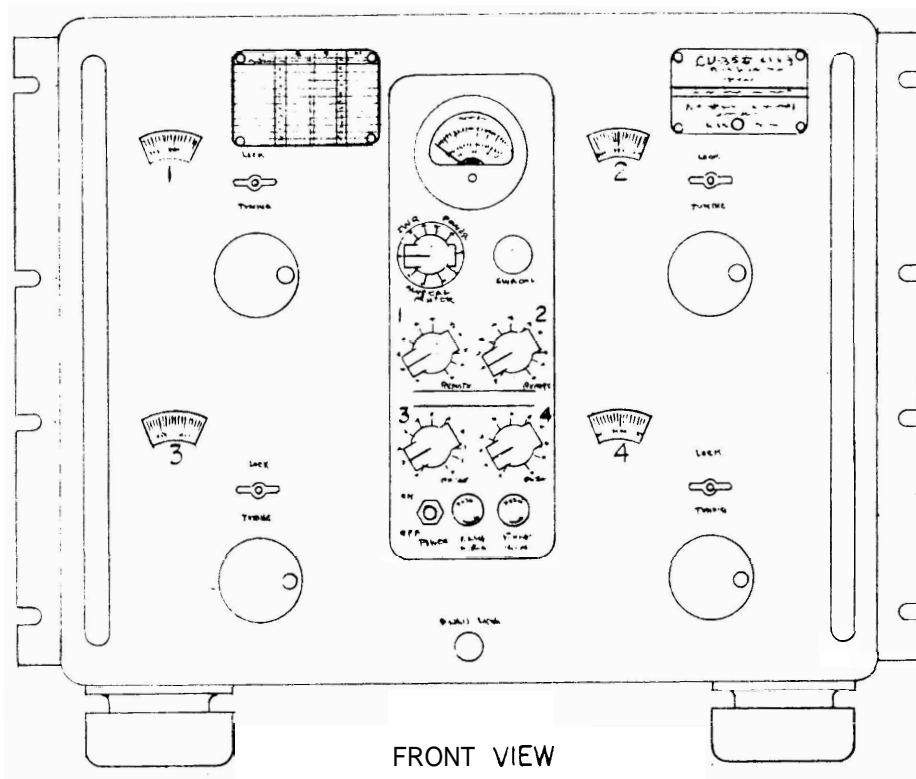

Figure 3-9. Antenna Coupler CU-355(XN-1)/UR

5. ANTENNA COUPLER CU-355/UR .

a. GENERAL DESCRIPTION. - Antenna Coupler CU-355/UR provides for the simultaneous operation of four UHF transmitters and/or receivers into a single antenna in the frequency range of 225 to 400 mc (see Figure 3-9). In addition to the advantage of simplifying antenna installations, the coupler improves the performance of equipments connected to it by discriminating against spurious responses and emissions.

The coupler has four cavities which are independently tuned either automatically or manually. For automatic tuning each cavity must be pre-tuned to 10 corresponding channels in the frequency range of the attached transmitter or receiver. Each cavity thereafter is automatically retuned by an autotune mechanism. Manual tuning of each

cavity is possible when the autotune locks are disengaged.

b. MAIN COMPONENTS. - The equipment that is supplied with Antenna Coupler CU-355/UR is listed in Table 3-3. The mechanism of the unit is mounted on a single rigid casting and enclosed in a formed aluminum cabinet. Manual tuning controls and pre-set channel selector switches; as well as a power-monitor meter are provided on the front panel. Each cavity has a power monitor and standing wave ratio indicator. A twelve-position switch on the front panel of the coupler permits reading power or standing wave ratio at any one of the four inputs on a signal meter on the front panel.

Antenna Coupler CU-355/UR may be operated remotely but the remote control equipment is not supplied.

TABLE 3-3. EQUIPMENT SUPPLIED WITH ANTENNA COUPLER CU-355/UR

Unit	Type Designation	Qty.	Overall Dimensions (inches)			Weight (lbs)
			Height	Width	Depth	
Antenna Coupler		1	14	17-1/2	24	100
Mounting Brackets		2				
Mating Connectors	UG-21B/U	4				
	UG-59A/U	1				
	AN-3108B-20-27S	4				
	AN-3108B-18-3S	1				

c. REFERENCE DATA.

- (1) FREQUENCY RANGE:  
225 to 400 mc
- (2) CHARACTERISTIC IMPEDANCE  
50 ohms
- (3) TYPE OF TUNING:  
Closed coaxial line resonators
- (4) POWER REQUIREMENTS:  
1P5 volts AC, single phase, 60 cycles (for automatic tuning)
- (5) MAXIMUM RF INPUT POWER:  
200 watts

d. INSTALLATION. - Antenna Cou-

pler CU-355/UR may be table or rack mounted. In order to table mount, four Barry C-2090-6 shock mounts are attached to the coupler and the shock-mounted unit is secured to the table top.

In order to mount in a standard relay rack remove the aluminum cabinet and secure the two rack mounting angles which are stored inside the cabinet to the sides of the front panel; Place the Antenna Coupler upon the rails which run from the front to the rear uprights of the standard relay rack. Secure the rack mounting angles to the front uprights of the rack.

The operating frequencies of the group must be separated by one megacycle or more, depending on the characteristics of the auxiliary equipment.

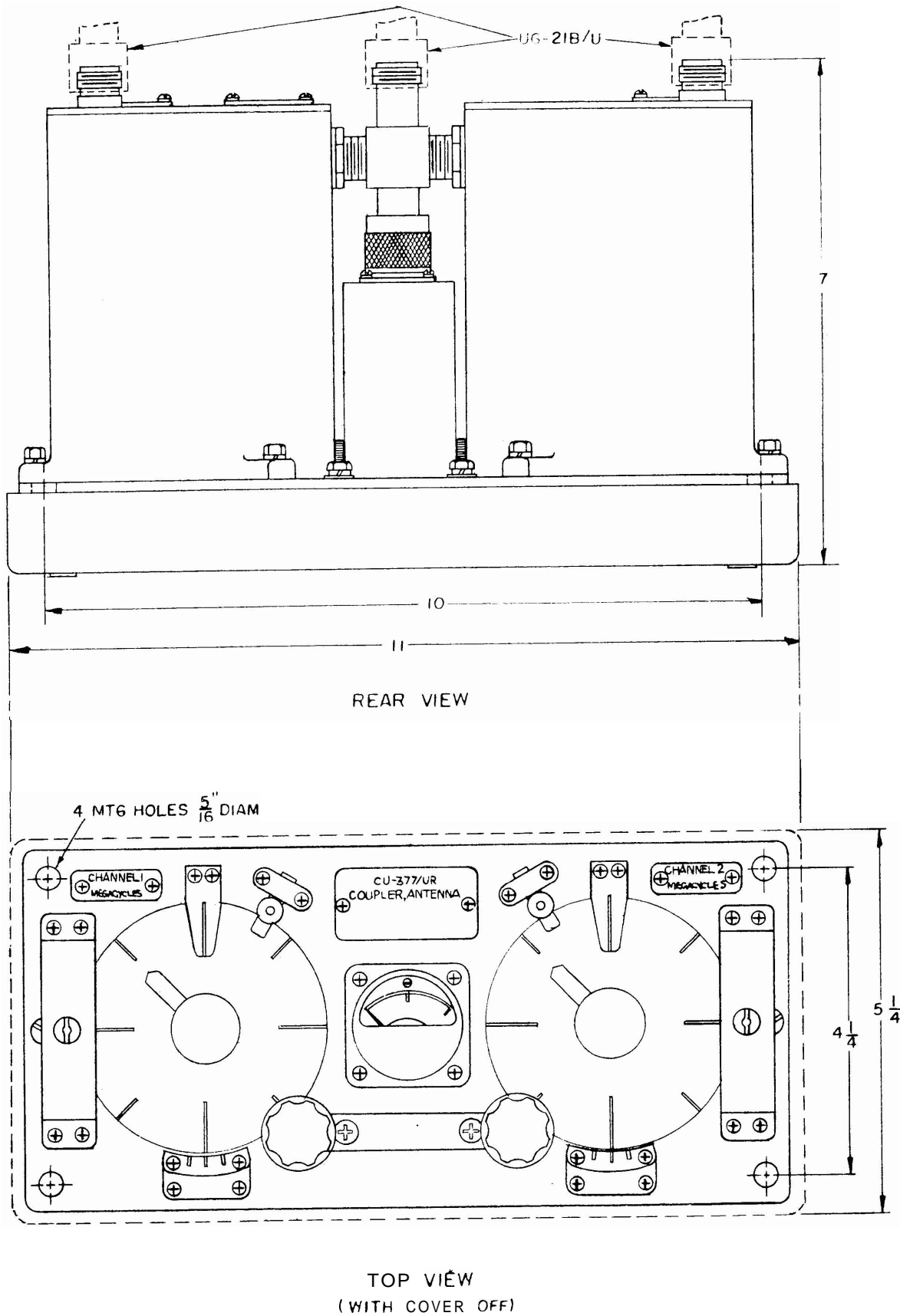

Figure 3-10. Antenna Coupler CU-377/UR

6. ANTENNA COUPLER CU-377/UR.

a. GENERAL DESCRIPTION. - Antenna Coupler CU-377/UR (see Figure 3-10) permits the simultaneous operation of two UHF transmitters or receivers into a single antenna in the frequency range of 225 to 400 mc.

This coupler is similar to Antenna Coupler CU-284/UR except that it has better resettability, lower insertion loss and greater adjacent channel separation.

Antenna Coupler CU-377/UR is primarily intended for use with Navy Models TED and AN/URR-13 UHF radio transmitting and receiving equipment.

b. REFERENCE DATA.

- (1) WEIGHT: 9.5 pounds

- (2) FREQUENCY RANGE:  
225-400 mc
- (3) OUTPUT IMPEDANCE:  
50 ohms
- (4) TYPE OF TUNNING:  
Manual tuning of capacitively-tuned cavities.
- (5) POWER REQUIREMENTS:  
None
- (6) INSTRUCTION BOOK:  
NavShips 92187

c. INSTALLATION. - The CU-377/UR Antenna Coupler may be mounted on the bulkhead or on the overhead. It has a dust cover which must be removed to give access to the tuning dials.

Three UG-21B/U connectors accommodate the transmission lines from the radio equipment and antenna.

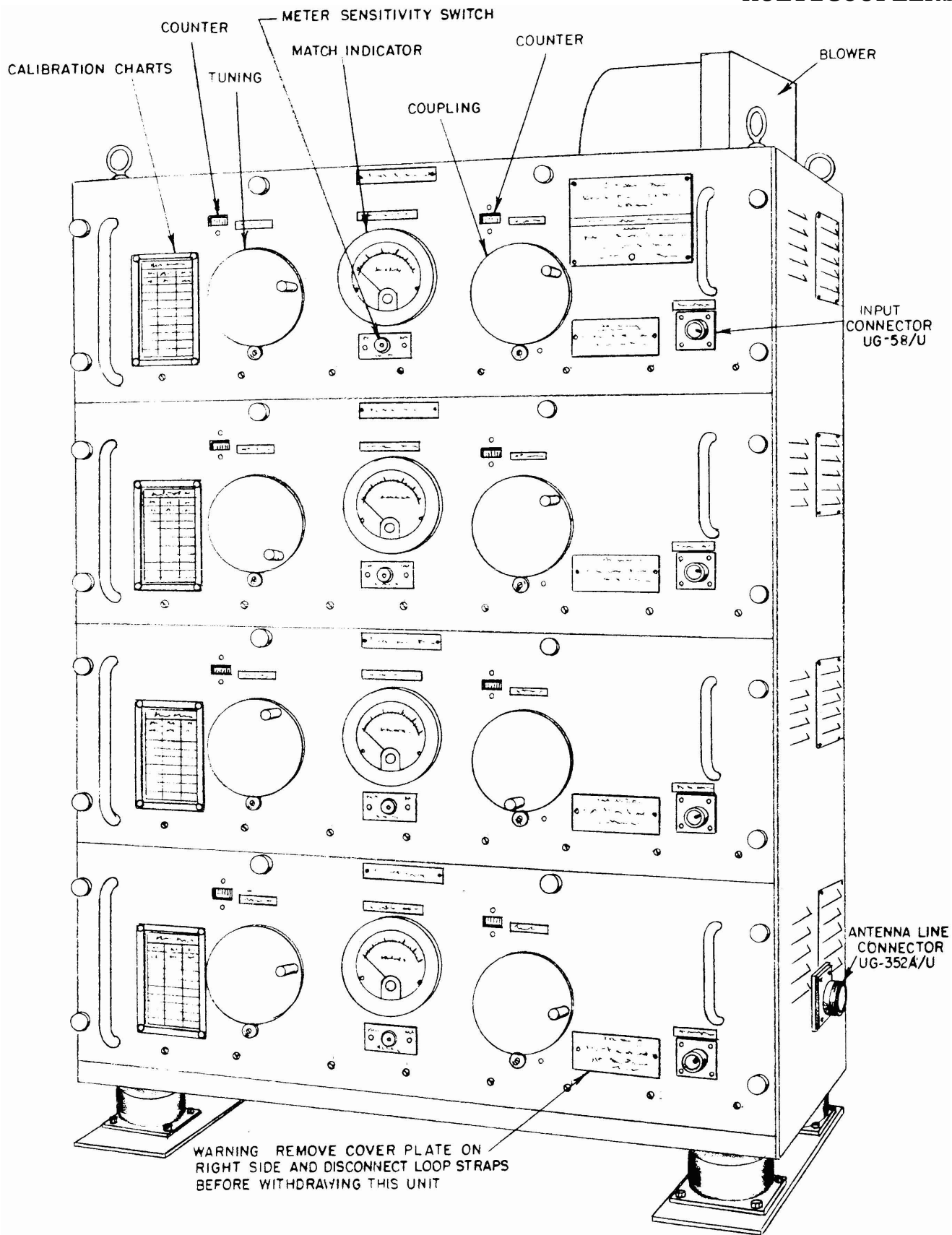

Figure 3-11. Antenna Multicoupler AN/SRA-15

SECTION 3-3

HF MULTICOUPLERS

1. GENERAL DESCRIPTION

A system of high frequency antenna couplers has been developed for simultaneously operating up to four transmitters into the same antenna in the frequency range of 2 to 26 mc. These antenna couplers are made up into four channel groups, each group operating in one of the following bands: L-6 mc, 4-12 mc, 6-18 mc and 9-26 mc. To obtain complete coverage from 2 to 26 mc, four coupler groups and four broad-band antennas are required. These experimental equipments are designed for installation on the USS Northampton (CLC-1).

The four types of antenna couplers in this system are listed in Table 3-4.

The AN/SRA-15 Antenna Coupler, which is typical of this group of couplers, provides for the simultaneous operation of four transmitting equipments, each with 500 watts output, into a single broad-band antenna (see Figures 3-11). It covers the frequency range from 6 to 18 mc and will operate into any antenna having a standing wave ratio, relative to 50-ohms, of 3 to 1 or better. The four transmitters connected to this coupler may be operated anywhere in the frequency range from 6 to 18 mc, as long as a separation of 10% is maintained between operating frequencies.

2. MAIN COMPONENTS.

Each antenna coupler consists of four drawer assemblies and a cabinet to house the drawers. Each drawer or coupler unit provides means for coupling a transmitter to the common antenna line.

The common antenna line extends from the antenna terminal to the topmost coupler unit in the cabinet. Here the line ends and is short-circuited. This line also has a section of the outer conductor cut away where it passes through each of the coupler units. At the cutaway sections the inner conductor is severed and the ends brought to two terminals. A one-turn loop is inserted in series with the inner conductor at these terminals in each of the coupler units. These loops provide coupling to the inductance of the capacity-tuned tank circuit in each unit. The tank capacity is tapped, providing an impedance-divider circuit which presents an input impedance of 50 ohms resistance when the unit is properly tuned. The combination of the tuneable tank and coupling circuits constitutes a transformer which matches the antenna impedance to the 50-ohm line to the transmitter and provides high efficiency in power transfer to the antenna. The high "Q" tank circuit provides the required isolation between channels when a 10% channel separation is maintained.

TABLE 3-4. HIGH FREQUENCY MULTICOUPLERS

Antenna Coupler	Frequency Range (mc)	Overall Dimensions (Inches)			Weight (lbs)
		Height	Width	Depth	
AN/SRA-13	2-6	33-1/2	25	18-3/4	253
AN/SRA-14	4-12	*33-1/2	25	15-3/4	223
AN/SRA-15	6-18	*33-1/2	25	15-3/4	218
AN/SRA-16	9-26	*28	28	21-5/8	295

\* Add 12" to height for blower motor and fan housing.

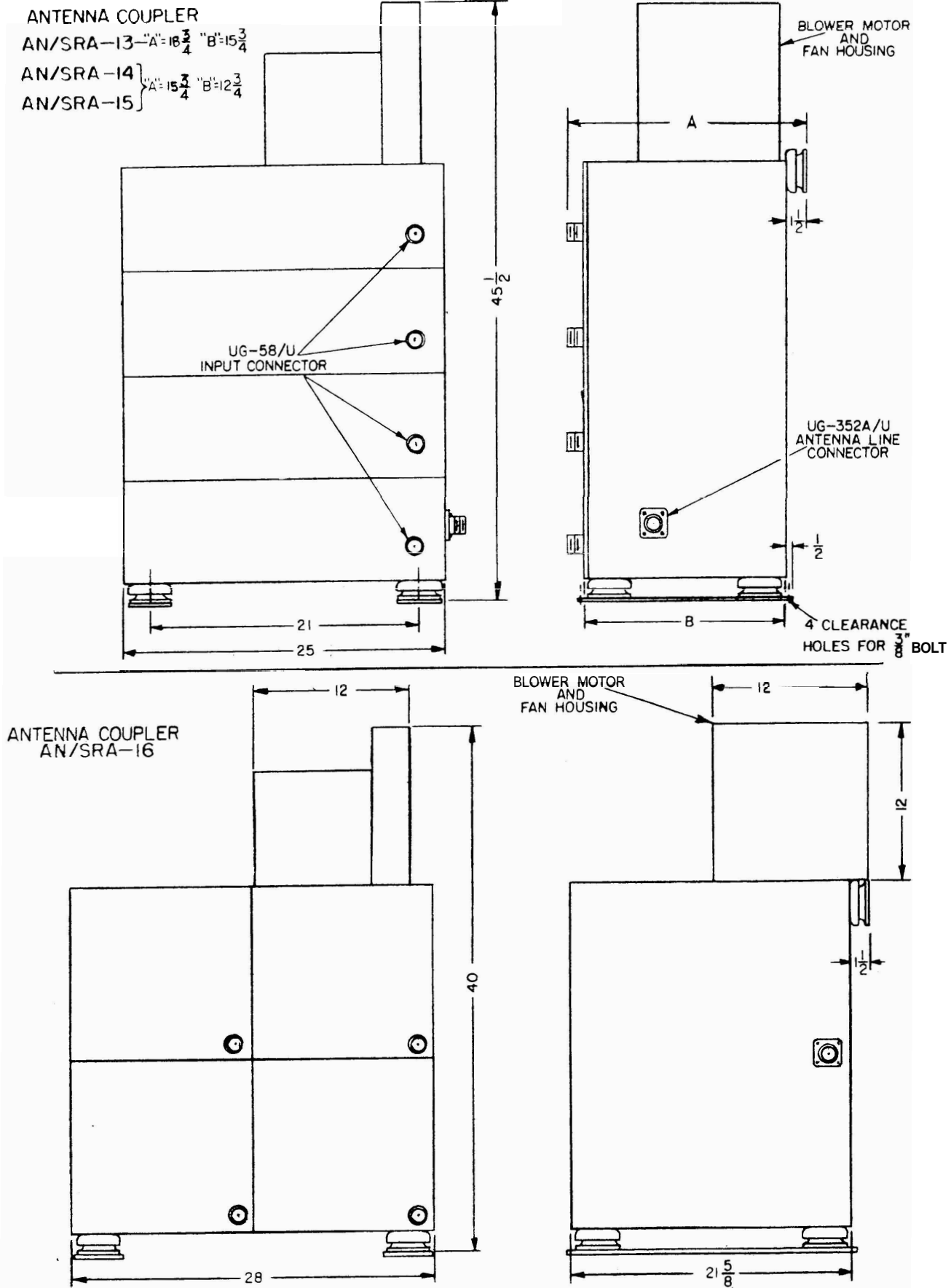

Figure 3-12. HF Antenna Multicoupler Installation Dimensions



Each coupler unit has a reflectometer or match indicator located in the transmission line from the transmitter. This device measures the reflected wave on the line from the transmitter and thus indicates the degree of mismatch presented by the coupler unit with respect to the 50-ohm line. The match indicator provides a means for adjusting the coupler unit. It is only necessary to adjust two controls for a minimum reading on the match indicator. It absorbs very little power from the line, and does not disturb the impedance of the line in the frequency range in use. It permits adjusting the unit for a standing wave ratio of 1.1 to 1.0 referred to a 50-ohm resistive load.

In order to fix the values of the performance factors and also to make the tuning of the units a simple matter, the input coupling capacitor and the tank tuning capacitor are ganged and operated by one control. The coupling loop is controlled separately; hence, each coupler unit is adjusted by means of two controls.

All four of these antenna coupler equipments have the same general design. Antenna Coupler AN/SRA-16 utilizes capacitive coupling and parallel operation as compared to the inductive coupling and series operation of the other three equipments. However, the input circuitry and the method of control, tuning indication, and operation are essentially the same. The performance factors are similar also.

### 3. REFERENCE DATA.

#### a. FREQUENCY RANGE:

2 to 26 mc

#### b. POWER REQUIREMENTS:

115 volts AC for blower motor. No power required for tuning the couplers.

#### c. POWER HANDLING CAPABILITY:

Will operate with transmitters having an output of 500 watts.

#### d. CHARACTERISTIC IMPEDANCE:

50 ohms

### 4. INSTALLATION.

The outline and mounting dimensions for these antenna couplers are given in Figure 3-12.

All of these equipments except the AN/SRA-13 have a blower motor and fan housing mounted on top of the cabinet.

The four coupler units of the AN/SRA-16 are stacked in a cluster-type arrangement; whereas, the units of the other three equipments are stacked one on top of another,

A clearance of at least 24 inches is required in front of the equipments for withdrawal of the coupler units from the cabinets. Adequate clearance on the right side must be provided for bending the RG-18/U antenna line.

These equipments were designed for use on large ships where space is available for the required broad-band antennas.

When these equipments are installed aboard the CLC-1, a 50-ohm resistive load will be provided at each of the antenna coupler positions. The transmission line from a transmitter being set up will be connected to a 50-ohm load for all tuning and calibrating of its controls. An antenna coupler being set up for the first time will be set in accordance with the typical tuning curves shown in the instruction book. Then the line from the transmitter, which has been connected to the 50-ohm load during transmitter tuning, will be transferred to the antenna coupler. With the transmitter in the tune position, the antenna coupler tuning will be completed. The transmitter will then be set to "Operate" and a final trimming of its controls performed.

These antenna couplers provide an isolation or voltage ratio of 15 to 1. This gives a greater degree of isolation between transmitting equipments than is generally needed, but it has the additional effect of reducing the tendency toward interaction between units.

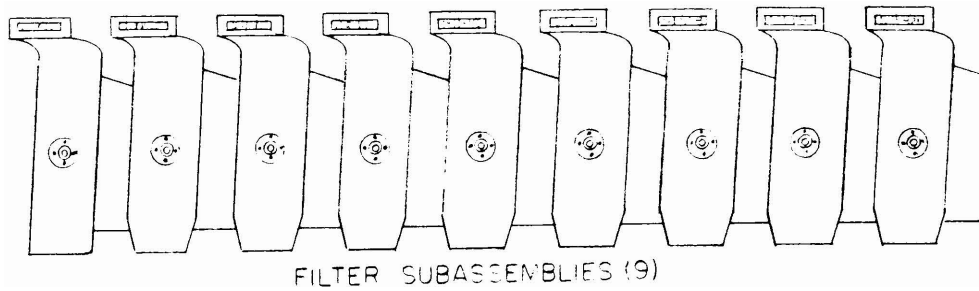

FILTER SUBASSEMBLIES (9)

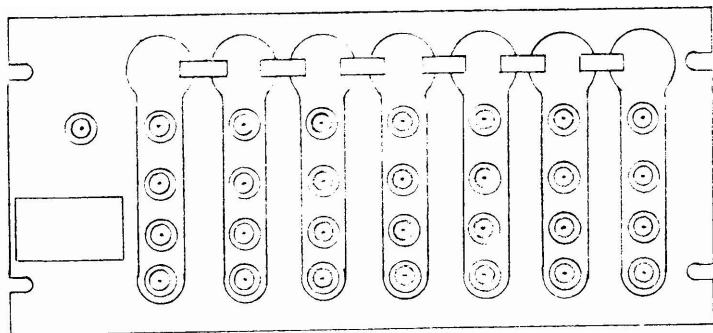

PANEL, FILTER J-462/SRA-9

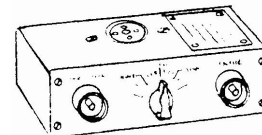

TEST SET, FILTER  
TS-734A/SRA-9



SHORTING PLUG (3)

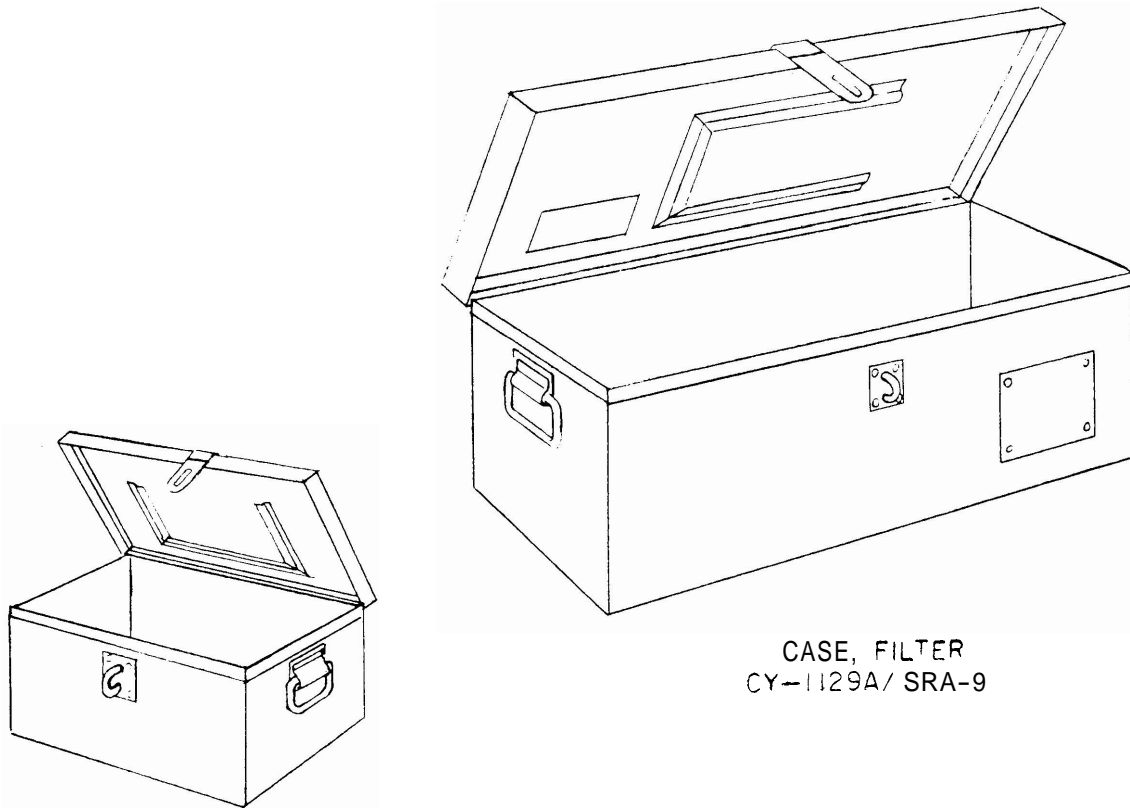

CASE, FILTER  
CY-1129A/SRA-9

CASE, FILTER  
CY-1325/SRA-9A

Figure 3-13. Filter Assembly, Electrical AN/SRA-9A

SECTION 3-4

FILTER TYPE MULTICOUPLERS

1. RECEIVING FILTER ASSEMBLY AN/SRA-9A.

a. GENERAL DESCRIPTION. - Filter Assembly, Electrical AN/SRA-9A (see Figure 3-13) makes possible the multiple operation of a maximum of 28 radio receivers from a single antenna. (It is preferable, however, to limit each AN/SRA-9A to a total of 7 receivers.) This filter assembly or "multicoupler" provides seven RF channels in the frequency range from 14 kc to 32 mc. Any or all of these channels may be used independently of and simultaneously with any of the other channels. Connections to the receivers are made by coaxial patch cords in a manner similar to that employed with conventional antenna patch panels now in use on shipboard.

Separation of the frequency range into channels is accomplished by combinations of filter subassemblies which plug into the main chassis. Each filter subassembly consists of complementary high-pass and low-pass filter sections, the common crossover frequency of

which marks the division between channels.

The filters not only guard against interference at frequencies falling outside the channel being used but also prevent receivers connected to alternate rows of jacks from interacting with each other when their tuning and trimming adjustments are made.

Filter Assembly, Electrical AN/SRA-9A is designed to withstand impressed signals as great as 50 volts when the equipment is terminated in resistive loads not exceeding 180 ohms. Although the open circuit voltage introduced into a receiving antenna when it is closely coupled to a high-power transmitting antenna may well be in excess of 100 volts, the upper limit of 50 volts will seldom be exceeded when these antennas are terminated in moderately low impedances such as are normally encountered aboard ship.

b. MAIN COMPONENTS. - The equipment that is supplied with the AN/SRA-9A will be found listed below in Table 3-5.

TABLE 3-5. EQUIPMENT SUPPLIED WITH AN/SRA-9A

Qty.	Name of Unit	Type Number	Overall Dimensions (Inches)			Weight (pounds)
			H	W	D	
1	Panel Filter	J-482/SRA-9	8-2/3	19	2-1/8	10.25
9	Filter Subassemblies		4	2	3	18 total 2 (avg)
1	Test Set, Filter	TS-734A/SRA-9	2	6-1/4	3-1/2	1
3	Dummy, Connector Plugs		1-7/8	1-1/4 diam.		
1	Case, Filter	CY-1129A/SRA-9	9-1/2	25-1/4	12-3/4	24.6
		or CY-1325/SRA-9A	6-1/4	12-3/8	9-3/8	12.12

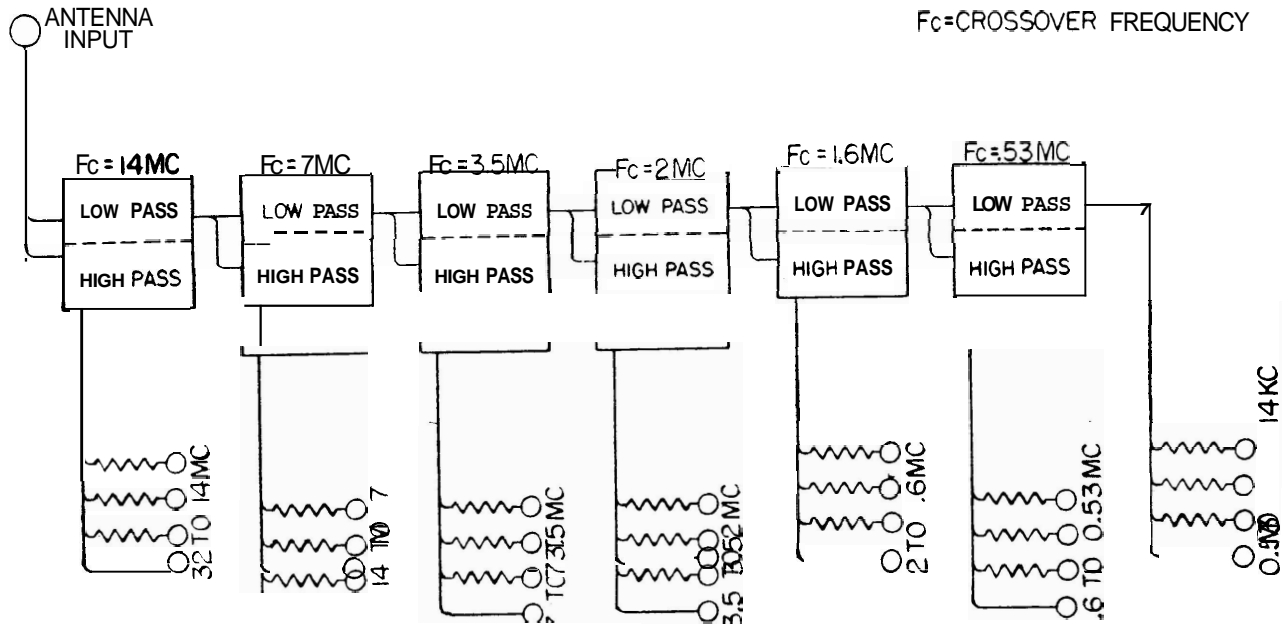

SCHEMATIC DIAGRAM

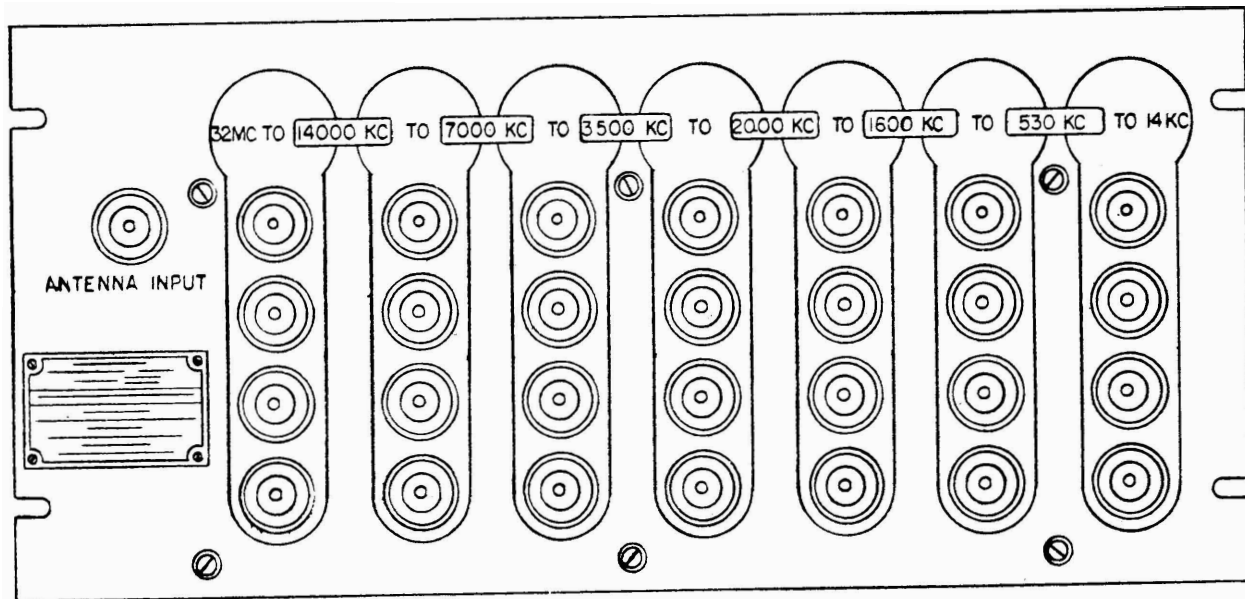

Figure 3-14. Filter Assembly, Electrical F-145/SRA-9

(1) FILTER ASSEMBLY, ELECTRICAL F-145/SRA-9, consists of a Panel, Filter J-482/SRA-9 and a set of nine filter subassemblies, any six of which can be used at one time (see Figure 3-14). The filter subassemblies are sealed units consisting of inductors and capacitors and are terminated in four-terminal plugs which are designed to engage octal receptacles on the main chassis. The subassemblies have numbers stamped on them which indicate their crossover frequencies. These numbers can be viewed through windows in the front panel. The six subassemblies that are to be used should be assembled in the order of decreasing frequencies from left to right as viewed from the front of the panel.

Panel, Filter J-482/SRA-9 contains one antenna input jack, 28 output jacks, 21 decoupling resistors and 6 octal sockets. The antenna input jack and the 28 output jacks are all Navy Type-49120 KF connectors. (Eventually, it is planned to replace these jacks with Type C quick-disconnect connectors.) The filter subassemblies plug into the octal sockets in the rear of the main chassis. The bottom jack in each row of output jacks is painted red to indicate that it is connected directly to its subassembly. The other three output jacks in each row are unpainted to denote that they are decoupled from their corresponding subassemblies by 300-ohm resistors. The front panel may be removed from the main chassis for servicing by removing six machine screws.

To keep losses at a minimum, the input and output of Filter Assembly F-145/SRA-9 are to be terminated in 180 ohms. However, only a slight reflection loss (of the order of 1.0 db) results when the input is terminated in 70 ohms, a value typical of the impedance of RF cables used in receiving antenna installations aboard ship.

(2) TEST SET, FILTER TS-734A/SRA-9 (Std. Navy Stock No. N16-A-22081-1028) is used to check the performance characteristics of any of the filter subassemblies.

(3) CASE, FILTER CY-1129A/SRA-9 is constructed of heavy metal and is fitted with wooden inserts which provide compartments for stowing all nine filter subassemblies, the three dummy connector plugs, J-482/SRA-9 and TS-734A/SRA-9. This case is furnished when an AN/SRA-9A equipment is to be stowed away from an operating position and the components subsequently used as replacements.

(4) CASE, FILTER CY-1325/SRA-9A is a metal case smaller than CY-1129A/SRA-9 but similarly fitted with wooden inserts divided into stowage compartments. This case provides stowage space for three of the filter subassemblies, the three dummy connector plugs, and TS-734A/SRA-9 at the operating position aboard ship.

(5) DUMMY, CONNECTOR PLUGS (Std. Navy Stock No. N17-C-11542-3501). Three of these shorting plugs are supplied with the AN/SRA-9A. When substituted for a filter subassembly, the plug replaces the low-pass filter with a direct connection. The row of jacks associated with the socket into which the plug is inserted will be rendered inoperative since the plug does not serve the purpose of the high-pass filter.

c. REFERENCE DATA.

(1) FREQUENCY RANGE:  
14 kc to 32 mc

(2) PRIMARY POWER REQUIREMENTS: None

(3) CHARACTERISTIC IMPEDANCE:  
180 ohms

(4) POWER HANDLING CAPABILITIES:

The units are designed to handle 50 watts. This should be sufficient to dissipate the energy picked up by the receiving antenna from nearby transmitting antennae.

(5) CONTROLS: None. Selection of proper frequency range is accomplished by plugging the receivers into the proper row of jacks.

TABLE 3-6. FILTER SUBASSEMBLIES SUPPLIED WITH AN/SRA-9A

Unit	Manufacturer's Part Number	Crossover Frequency	Standard Navy Stock Number
Filter, Band Pass	1421	50 kc	N16-F-32558-5354
Filter, Band Pass	1422	150 kc	N16-F-32608-3241
Filter, Band Pass	1423	300 kc	N16-F-32635-6249
Filter, Band Pass	1424	530 kc	N16-F-32677-5761
Filter, Band Pass	1425	1600 kc	N16-F-32682-3289
Filter, Band Pass	14Z6	2000 kc	N16-F-32686-7361
Filter, Band Pass	1427	3500 kc	N16-F-32700-1361
Filter, Band Pass	1428	7000 kc	N16-F-32705-5361
Filter, Band Pass	14Z9	14,000 kc	N16-F-32716-5079

(6) INTERCHANGEABILITY:

All plug-in assemblies are interchangeable from socket to socket and from unit to unit. It is necessary, however, that all subassemblies be installed in the order of decreasing frequencies from left to right, as viewed from the front.

(7) INSTRUCTION BOOK:

NavShips 91770

d. INSTALLATION.

(1) FILTER SUBASSEMBLY SELECTION. - Selection of the proper combinations of filter subassemblies must be made before Filter Assembly, Electrical F-145/SRA-9 is installed in its permanent location aboard ship. Selection of subassemblies is dependent upon the types of receivers and antennas to be used and the frequency ranges to be covered. The nine filter subassemblies supplied with the equipments are listed in Table 3-6.

The filter subassemblies are designed to be used with existing communications

receivers as well as with new receiving and terminal equipment scheduled for future distribution to the Fleet. Receiver frequency ranges will determine which filter subassembly will be used with any given receiver. For example, if a large number of Model RBC receivers is available, a proportionately large number of high frequency subassemblies would be employed. On the other hand, with the Model RBA and RBB receivers, use of medium and low frequency subassemblies would be indicated.

Selection of the proper antenna to be used in conjunction with Filter Assembly, Electrical F-145/SRA-9 is dependent upon the frequency ranges to be covered. Short antennas shall be used with high frequency ranges: long-wire or flat-top antennas shall be used with medium and low frequency ranges.

(2) FILTER SUBASSEMBLY INSTALLATION. - When the proper filter subassemblies covering all frequencies over which operation is to be conducted have been selected they are plugged into the octal sockets on the rear of the main

**chassis.** For normal operation, it is imperative that the frequency ranges of the filter subassemblies (identified by their crossover-frequency labels as seen from the front of the Filter Assembly, Electrical F-145/SRA-9) progress from the lowest on the right to the highest on the left. After each subassembly has been plugged into its socket, it is to be secured to the panel by means of the machine screws through its top and bottom flanges. Do not rely on the four-terminal plugs for support of the subassemblies. Make certain the machine screws are secured tightly before the filter assembly is installed in its rack mounting.

(3) **INSTALLATION OF THE COMPLETE UNIT.** - With the filter subassemblies in place, Filter Assembly, Electrical F-145/SRA-9 is mounted in a standard 19-inch relay rack. Six machine screws fasten Panel, Filter J-482/SRA-9 to the main chassis. Four additional screws secure the complete unit to the relay rack. It is recommended that a clearance of at least 18-inches be maintained behind the rack in order that the subassemblies may be easily changed.

The receivers and filter assemblies should be arranged in such a manner that the length of interconnecting cables is kept to a minimum consistent with requirements for operation, maintenance and servicing.

In normal operation, the filters dissipate little heat and therefore no provision for additional ventilation is necessary in the radio rooms.

e. **OPERATION.**

(1) **CHANNEL SELECTION.** - Since Navy communications receivers generally operate throughout frequency bands which exceed the widths of the channels normally provided by the filter subas-

semblies, it is emphasized that a given receiver must be connected to the particular row of output jacks which provides the desired signals. To illustrate this point, when using a Model RBC receiver with the filter equipment in Figure 3-14, it will be necessary to change the position of the patch-cord which feeds this receiver when the receiver is tuned to a channel in another filter subassembly (for example, from the 7,000-14,000 kc band to the 14,000 kc-32 mc band).

(2) **OUTPUT JACK SELECTION.** - When necessary, the bands of frequencies available in a given row of output jacks may be changed either by using different combination of subassemblies or by removing various subassemblies and inserting "shorting plugs" which are provided with the equipment. These shorting plugs provide continuity between successive subassemblies, as required when testing or when a subassembly is removed for any reason, without the necessity for changing the position of the remaining subassemblies.

The red-painted jacks at the bottom of each row, being directly connected to the subassemblies, should be used whenever maximum signal strength is desired. The other (unpainted) jacks, being decoupled by 300-ohm resistors, are suitable for use with relatively strong signals or with those which are of somewhat secondary importance. In the ideal arrangement only one receiver would be connected directly (i. e. at the red jack) to each assembly, thus providing for maximum of seven directly connected receivers with each antenna. At frequencies somewhat removed from the crossover points, the performance of each of these seven receivers should be comparable with that obtained if a receiver were directly connected to the antenna. Likewise, the performance of twenty-one receivers connected to the "decoupled jacks" should be comparable with the performance of three receivers decoupled in like manner using conventional patch-panels with a given antenna.

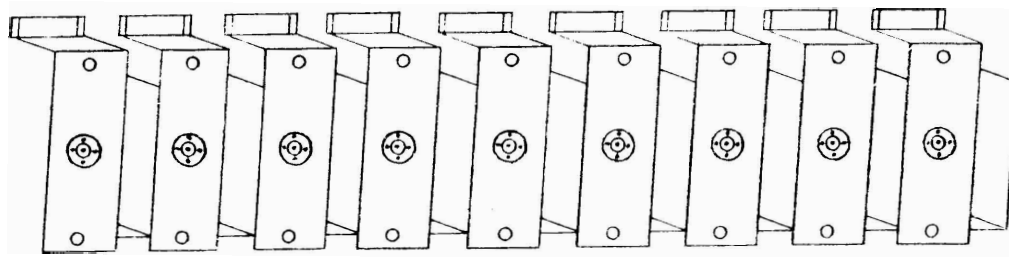

FILTER SUBASSEMBLIES (9)

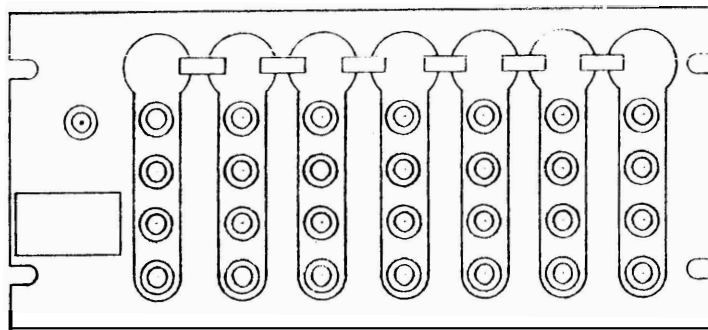

FILTER PANEL SB-404/SRA-12



SHORTING PLUGS (3)

Figure 3-15. Filter Assembly, Electrical AN/SRA-12



2. RECEIVING FILTER ASSEMBLY  
AN/SRA-12.

Aside from these differences the AN/SRA-12 is similar in appearance and operation to the AN/SRA-9 and AN/SRA-9A.

a. GENERAL DESCRIPTION. - Filter Assembly, Electrical AN/SRA-12 (see Figure 3-15) is similar to but does not replace the AN/SRA-9 and AN/SRA-9A filter assemblies. The differences between the AN/SRA-12 and AN/SRA-9 and AN/SRA-9A are that the AN/SRA-12 employs Receptacle Connector UG-1111/U and Plug Connector UG-968/U which are improved quick-disconnect type r-f connectors, whereas the AN/SRA-9 and AN/SRA-9A use the obsolete connectors, Types 49120 and 49121. The AN/SRA-12 also incorporates a special switch at each of the seven direct-output jacks for automatically cutting in a terminating resistor when the plugs are removed from these output terminals. These terminating resistors minimize losses when connected by terminating each of the receptacles in the bottom row in the characteristic impedance of the filter assembly. Although the characteristic impedance is mismatched when the bottom receptacle of any row is in use, the disadvantage of the slight reflection losses is more than compensated for by permitting the construction of inductors and capacitors for practical size.

b. MAIN COMPONENTS. - The equipment that is supplied with the AN/SRA-12 Filter Assembly will be found listed below in Table 3-7.

(1) Electrical Filter Assembly AN/SRA-12 comprises Filter Panel SB-404/SRA-12, nine filter subassemblies, and three shorting plugs.

(2) FILTER PANEL SB-404/SRA-12. - Filter Panel SB-404/SRA-12 is a rack-mounted equipment with six octal receptacles on its rear face to accommodate any six of the nine filter subassemblies supplied. On the front face of the panel are 28 quick-disconnect coaxial output receptacles and one antenna input coaxial receptacle. These provide, respectively, ready connections to receivers and to an antenna or their associated patch panels.

To keep losses at a minimum, the input and output of Filter Assembly AN/SRA-12 are to be terminated in 180 ohms. However, only a slight reflection loss (of the order of 1.0 db) results when

TABLE 3-7. EQUIPMENT SUPPLIED WITH AN/SRA-12

Qty.	Name of Unit	Type Number	Overall Dimensions (Inches)			Weight (lbs)
			H	W	D	
1	Panel, Filter	SB-404/SRA-12	8-3/4	19	2-1/8	10.25
9	Filter Subassemblies		4	2-1/16	3-7/16	18, total 2 (avg)
3	Shorting Plugs		1-25/32	1-1/4 diam.		
29	Connector, Plug	UG-968/U	1-51/64	1 diam.		

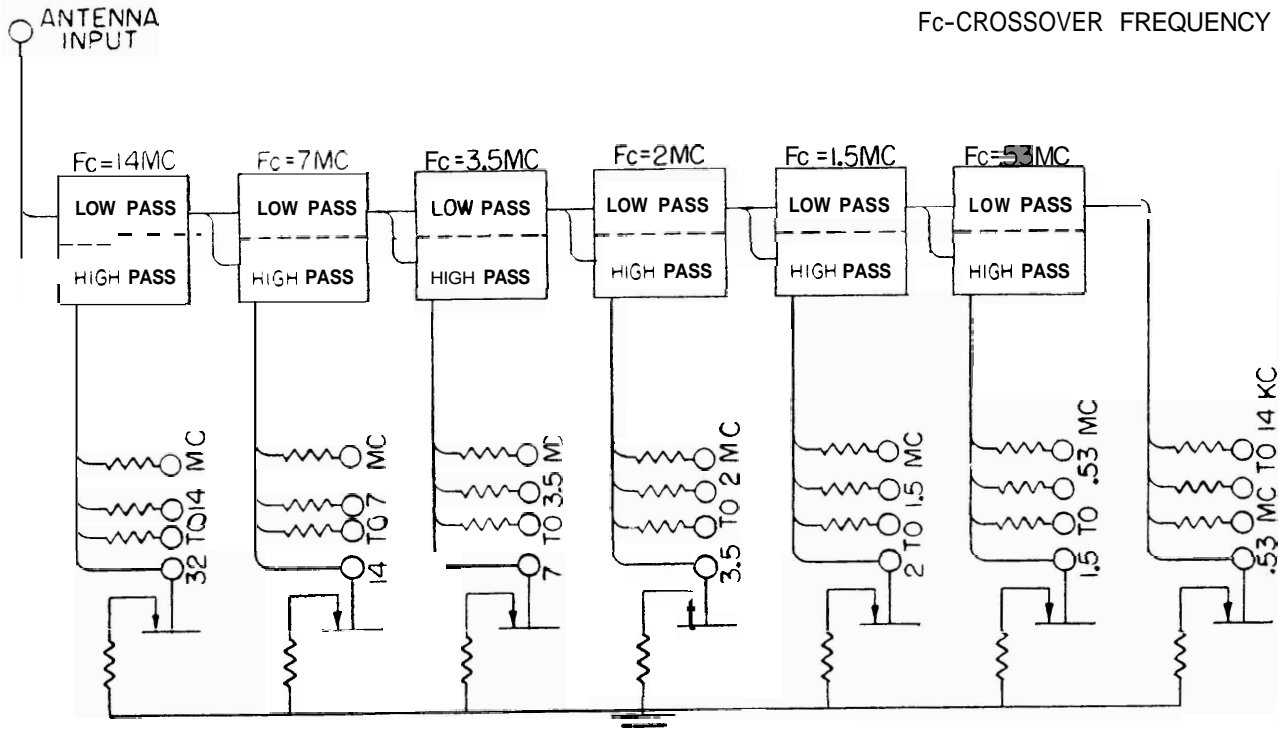

SCHEMATIC DIAGRAM

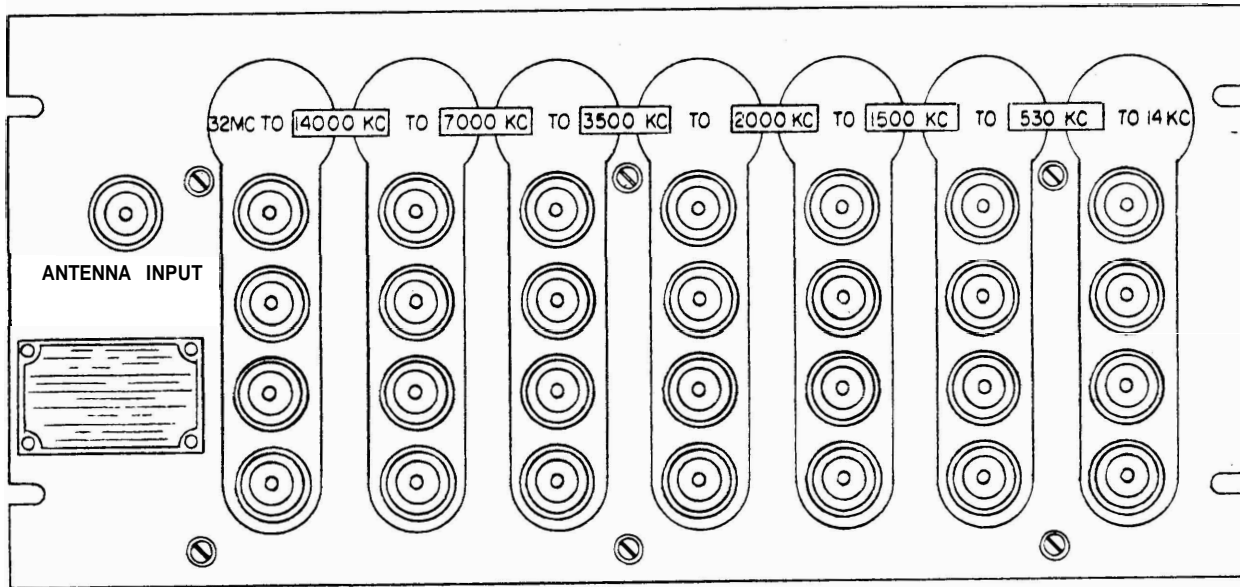

Figure 3-16. Filter Assembly, Electrical AN/SRA-12

the input is terminated in 52 ohms, a value typical of the impedance of RF cables used in receiving antenna installations aboard ship.

(3) FILTER SUBASSEMBLIES.—Nine filter subassemblies, designed for insertion into the octal sockets on the rear face of Filter Panel SB-404/SRA-12, are provided. Each is a hermetically sealed unit, factory calibrated, consisting essentially of inductors and capacitors. Each is identified by its cross-over frequency and by its standard Navy stock number. Each subassembly is fitted with a four-prong male plug, keyed and mating with a standard female octal socket. Any six of these subassemblies may be used at one time to provide a band of frequencies for reception in the 14 kilocycle-to-32 megacycle range.

The nine filter subassemblies supplied with the equipments are listed in Table 3-8.

(4) SHORTING PLUGS.— Three shorting plugs (dummy plug connectors) are provided with the AN/SRA-12 equipment to provide continuity of the signal through the filter assembly in the event as many as three of the filter subassem-

blies are taken out of the circuit.

c. REFERENCE DATA.

(1) FREQUENCY RANGE:

14 kc to 32 mc

(2) PRIMARY POWER REQUIREMENTS: None

(3) CHARACTERISTIC IMPEDANCE: 180 ohms

(4) POWER HANDLING CAPABILITIES:

The units are designed to handle 50 watts. This should be sufficient to dissipate the energy picked up by the receiving antenna from nearby transmitting antennas.

(5) CONTROLS: None. Selection of proper frequency range is accomplished by plugging the receivers into the proper row of jacks.

(6) INTERCHANGEABILITY:

All plug-in assemblies are interchangeable from socket to socket and from unit to unit. It is necessary, however, that all subassemblies be installed in the order of decreasing frequencies from left to right, as viewed from the front.

(7) INSTRUCTION BOOK:

NavShips 92206

TABLE 3-8. FILTER SUBASSEMBLIES SUPPLIED WITH AN/SRA-12

Unit	Manufacturer's Part Number	Crossover Frequency	Standard Navy Stock Number
Filter, Band Pass	CBTC Z1	50 kc	N16-F-32558-5354
Filter, Band Pass	CBTC Z2	150 kc	N16-F-32608-3241
Filter, Band Pass	CRTC Z3	303 kc	N16-F-32635-6249
Filter, Band Pass	CBTC Z4	530 kc	N16-F-32677-5761
Filter, Band Pass	CBTC Z46	1500 kc	N16-F-41335-1901
Filter, Band Pass	CBTC Z6	2000 kc	N16-F-32686-7361
Filter, Band Pass	CBTC Z7	3500 kc	N16-F-32700-1361
Filter, Band Pass	CBTC Z8	7000 kc	N16-F-32705-5361
Filter, Band Pass	CBTC Z9	14,000 kc	N16-F-32716-5079

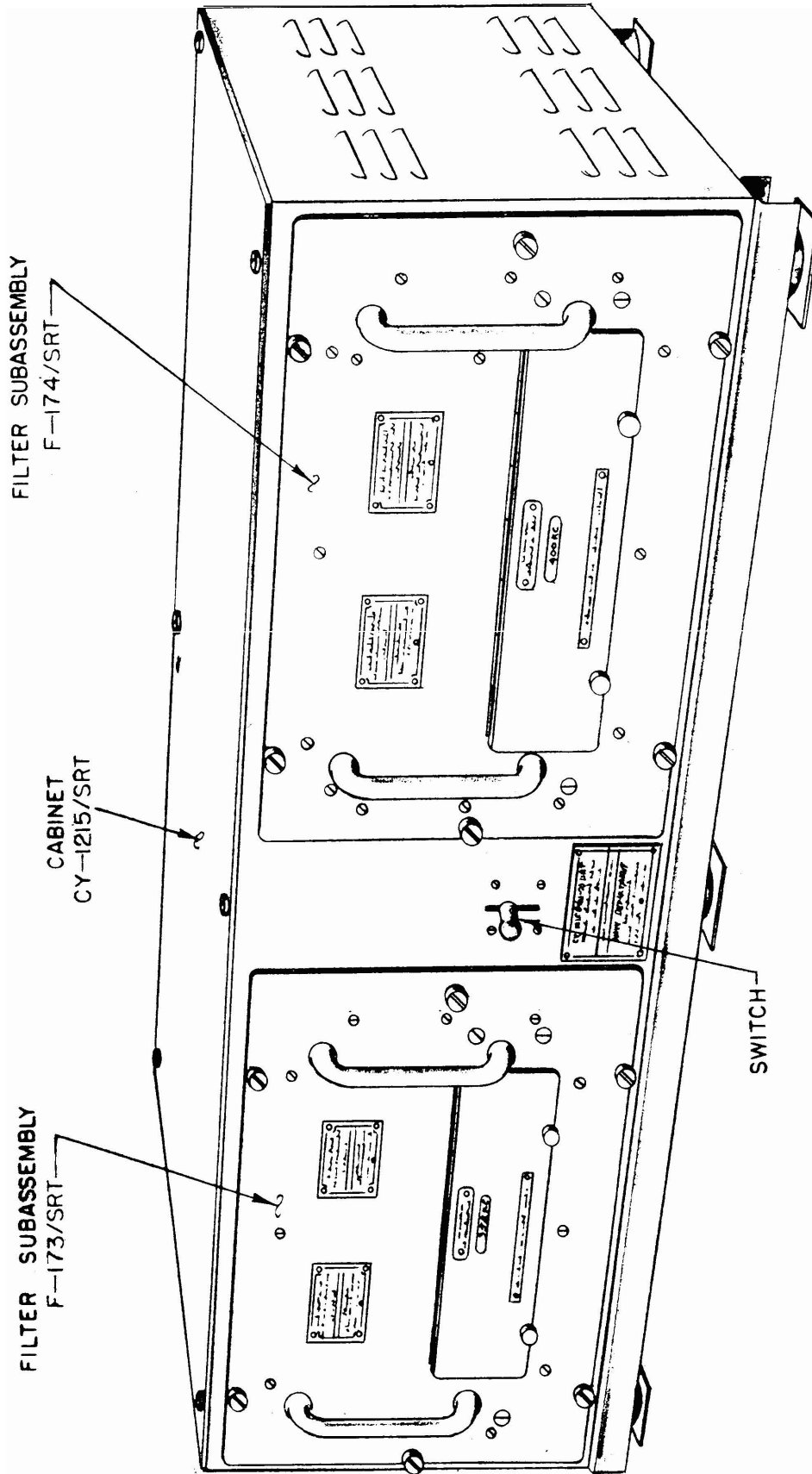

Figure 3-17. Filter Assembly, Electrical F-159/SRT

### 3. TRANSMITTING FILTER ASSEMBLIES.

a. GENERAL DESCRIPTION. - This series of filter assemblies has been designed for use with conventional shipboard transmitters and antennas which are unbalanced to ground. Each filter assembly consists of complementary low-pass and high-pass subassemblies having identical cut-off frequencies. They are used with radio transmitters operating in the frequency range from 175 kilocycles to 18.1 megacycles.

Each filter assembly can be used alone or in combination with other filter assemblies to provide means for simultaneous operation of two or more radio transmitters on different frequencies into a single antenna.

b. MAIN COMPONENTS. - This series of transmitting filter assemblies comprises five different filter assemblies for operation in five frequency ranges: Filter Assemblies, Electrical F-159/SRT, F-160/SRT, F-161/SRT, F-162/SRT and F-163/SRT.

Each filter assembly consists of three units: a cabinet, a low-pass subassembly and a high-pass subassembly (see Figure 3-17).

In the vicinity of the crossover frequency, there is a definite band of frequencies called the precluded band which, if used, would result in an appreciable loss of power within the filter. For this reason, all of these filter assemblies, except Filter Assembly, Electrical F-160/SRT, are equipped with a switch for changing their crossover frequencies. By changing the point of crossover, it is possible to obtain continuous coverage of the 175 kc to 18.1 mc frequency range.

The cabinet which houses the subassemblies is equipped with extension slides, making it possible to withdraw the units for inspection and servicing. A switch actuator is provided in each cabinet so that drawer assemblies with or without switches may be installed.

The filter subassemblies are constructed in the form of plug-in drawers. Each drawer has an inspection door on the front panel for visual inspection of the unit in operation. Normally, the low-pass drawer is installed on the left side of the cabinet and the high-pass drawer on the right, as viewed from the front. However, provisions have been made for interchanging the subassemblies from left to right in the cabinet by changing a connecting strap in each of the subassemblies.

Overall dimensions and weights of the various drawers and cabinets are given in Table 3-8, Equipment Supplied. In addition to the equipment listed in the table, a set of spare parts is supplied with each unit.

#### c. REFERENCE DATA.

(1) FREQUENCY RANGE:  
175 kc to 18.1 mc

(2) PRIMARY POWER REQUIREMENTS: None

(3) POWER HANDLING CAPABILITY;

Although the filter assemblies normally dissipate less than 20% of the RF power output of the associated transmitters, each filter subassembly is designed to dissipate over 500 watts if required: for example, under "fault" conditions (i. e. antenna shorted, antenna switch open, etc.).

m  
(4) CHARACTERISTIC IMPEDANCE:  
180 ohms

(5) CONTROLS:

With the exception of F-160/SRT, a lever on the front panel of the filter assembly shifts the crossover frequencies to permit continuous coverage of the frequency range.

(6) INTERCHANGEABILITY:

All plug-in assemblies are interchangeable from cabinet to cabinet and, with internal changes, from left to right in the cabinets.

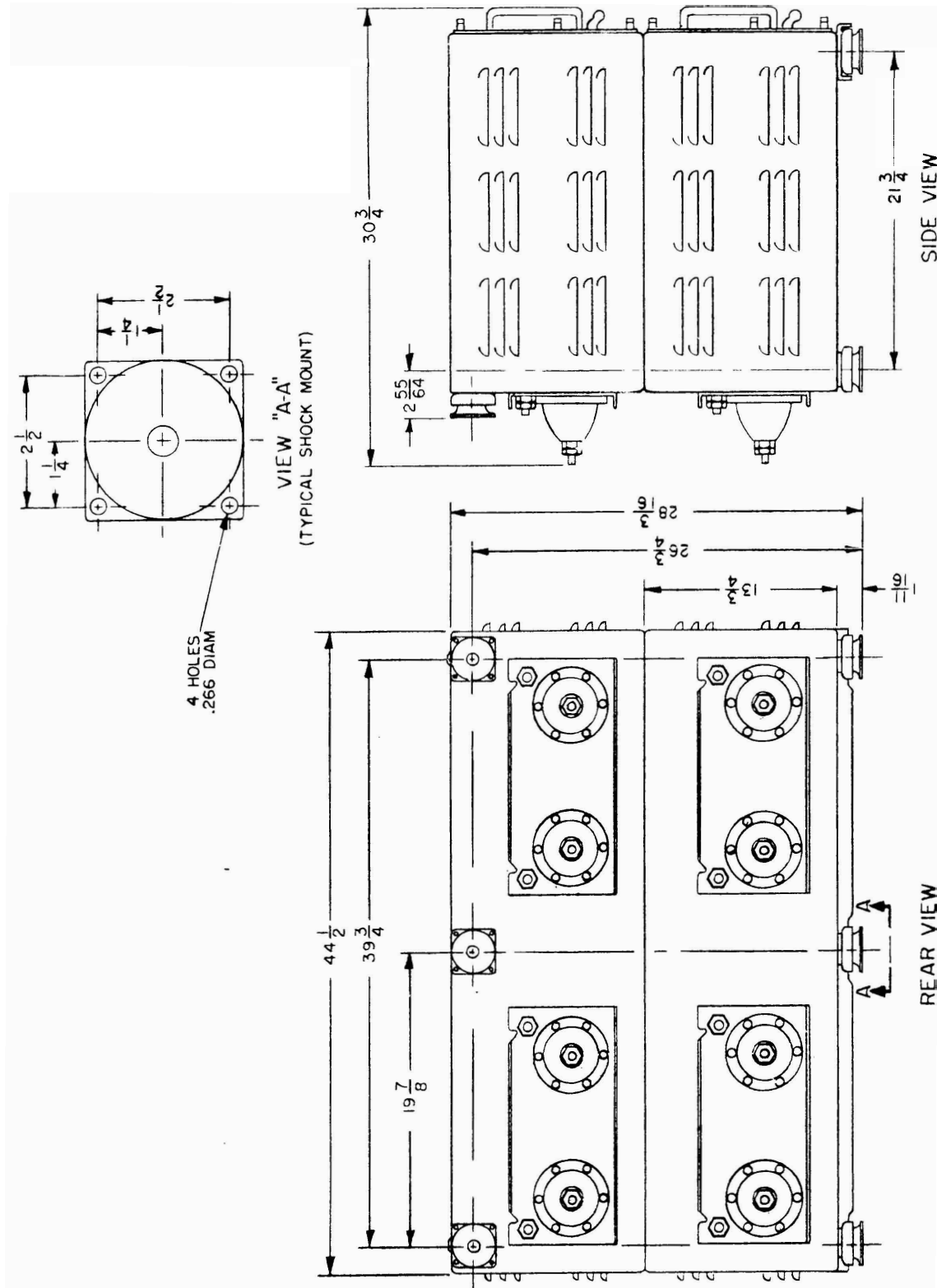

Figure 3-18. Two Cabinet Installation

TABLE 3-9. EQUIPMENT SUPPLIED WITH TRANSMITTING FILTER ASSEMBLIES.

Name of Unit	Type Designation	Overall Dimensions (Inches)			Weight (lbs)
		Height	Width	Depth	
Filter Assembly, Electrical F-159/SRT					245-1/2
Cabinet	CY-1215/SRT	13-1/4	44-1/2	30	92
Filter Subassembly	F-173/SRT	12-1/4	19-7/16	25-7/8	76-1/2
Filter Subassembly	F-174/SRT	12-1/4	19-7/16	25-7/8	77
Filter Assembly, Electrical F-160/SRT					176-1/2
Cabinet	CY-1215/SRT	13-1/4	44-1/2	30	92
Filter Subassembly	F-175/SRT	12-1/4	19-7/16	25-7/8	47-1/2
Filter Subassembly	F-176/SRT	12-1/4	19-7/16	25-7/8	37
Filter Assembly, Electrical F-161/SRT					185-1/2
Cabinet	CY-1215/SRT	13-1/4	44-1/2	30	92
Filter Subassembly	F-177/SRT	12-1/4	19-7/16	25-7/8	50
Filter Subassembly	F-178/SRT	12 - 1/4	19 - 7/16	25-7/8	43-1/2
Filter Assembly, Electrical F-162/SRT					
Cabinet	CY-1215/SRT	13-1/4	44-1/2	30	92
Filter Subassembly	F-179/SRT	12-1/4	19-7/16	25-7/8	
Filter Subassembly	F-180/SRT	12-1/4	19-7/16	25-7/8	
Filter Assembly, Electrical F-163/SRT					
Cabinet	CY-1215/SRT			30	92
Filter Subassembly	F-181/SRT	12-1/4	44-1/2	25-7/8	
Filter Subassembly	F-182/SRT	12-1/4	19-7/16	25-7/8	

d. INSTALLATION.

(1) GENERAL.- The filter assemblies are shipped with the subassemblies installed. The components of the subassemblies are pre-set and require no further adjustment. A check for possible breakage or loose connections should be made before putting the equipment in operation. The installation is completed by connecting appropriate transmitters and the antenna trunk line to the filter assembly.

The transmitters and associated filter assemblies should be as close together in the radio transmitting room as practicable, consistent with requirements concerning accessibility for operation, maintenance and servicing.

A clearance of 36 inches is required in front of the filter assembly for servicing and removing the plug-in subassemblies; a clearance of 18 inches is required in the rear for the 9" x 11" trunk which connects the filter assembly to the antennas.

(2) MOUNTING THE CABINETS.- There are several ways of installing the assemblies, ~~which~~ ~~must~~ the electrical requirements and the available space. The units may be stacked three high, two high or just one alone. In each case different shock mounts and shock mounting arrangements are required (see Figure 3-18).

(a) One Cabinet Installation. - Six shock mounts are required. In each of

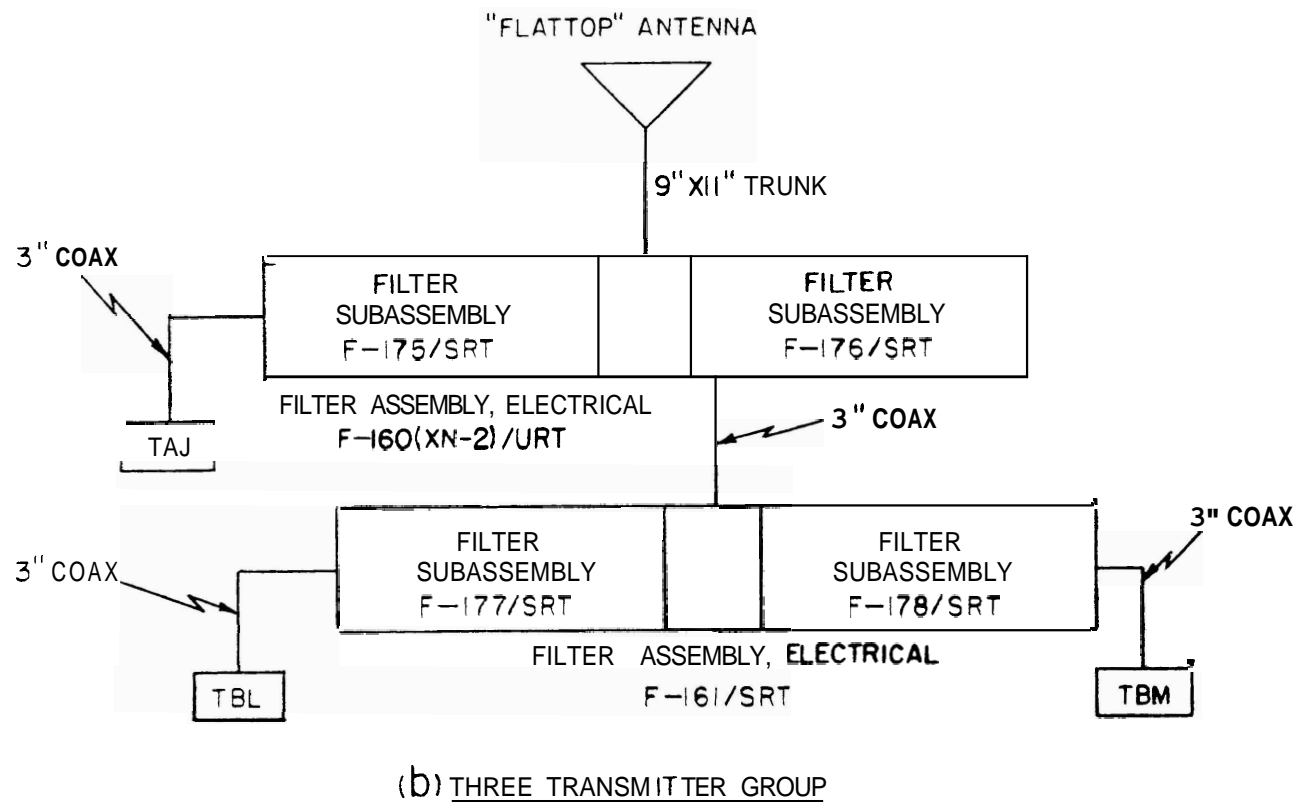
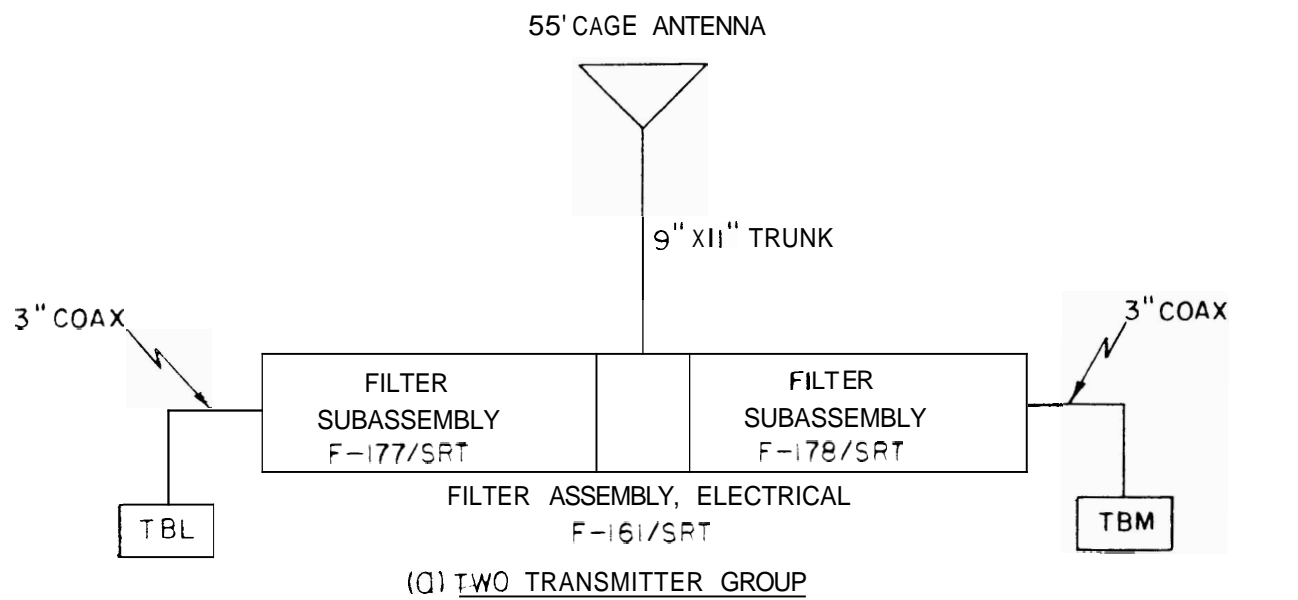

Figure 3-19. Typical Filter Assembly Installations



the four corners use "Barrymount" #C-2060-T6, and in the center use "Barrymount" #C-2150-T6. The dimensions for placing these shock mounts are shown in Figure 3-18, using the figures applicable to the base.

(b) Stacking Two Cabinets. - Nine shock mounts are required as shown in Figure 3-18. Use "Barrymount" #C-2045-T6 at the four bottom corners and "Barrymount" #C-2150-T6 at the bottom center. The upper rear bulkhead mounts are "Barrymount" #C-2150-T6. The center bulkhead mount is a "Barrymount" #C-2045-T6.

(c) Stacking Three Cabinets. - Six identical shock mounts are required in this arrangement. Use one "Barrymount" #C-2150-T6 at each of the four bottom corners of the lower cabinet and one at each of the upper rear corners of the top cabinet.

(3) FILTER ASSEMBLY SELECTION. - The choice of types and combinations of filter assemblies for a given installation depends upon the type of antenna and transmitter being used. Figure 3-19 (a) shows the Model TBL and TBM transmitters operating from a 55-foot cage antenna. Although the TBL can be operated at the lower frequencies in this installation, it is available for normal operations in the range from 2000 to 3500 kc while the TBM operates from 3500 to 18,000 kc. By replacing subassemblies F-175 and F-176, the TBL can be operated below 600 kc while the TBM covers its full frequency range from 2 to 18.1 mc.

A typical three-transmitter group using two filter assemblies is shown in Figure 3-19(b). The TAJ operates through out its full frequency range from 175 to 600 kc, while the TBL and TBM share 2 to 18.1 mc band in the manner described above.

A four-transmitter group may be formed by adding Filter Assembly F-159/SRT to Figure 3-19(b) at left, permitting operation of two TAJ transmitters along with the TBL and the TBM.

The added ventilation requirements due to a given filter installation aboard ship depend primarily upon the power output of the transmitters and the characteristics of the antenna system. It is assumed that one fifth of the rated output of the various transmitters will be dissipated within the filters in the form of heat.

e. OPERATION. - After the filter assembly has been properly installed and interconnected, the proper switch position for the transmitters used is the next consideration.

In Table 3-9, Frequency Coverage Chart, the frequencies above which and below which the transmitters are intended to be operated are given. These frequencies also appear on the front panel of each filter subassembly. Transmitters should not be operated at frequencies outside the limits specified.

In using Filter Assembly, Electrical F-161/SRT, for example, the low frequency transmitter may be on any frequency below 3025 kc when the switch handle is in the up position and the higher frequency transmitter may be on any frequency higher than 3500 kc. The band of frequencies in which neither transmitter should be operated is between 3025 kc and 3500 kc. If it becomes necessary to operate within this precluded band, the switch handle should be thrown to the down position. This shifts the precluded band to between 3500 kc and 4030 kc.

Since the low-pass section provides the termination for the high-pass section and vice versa, it is not advisable to operate a transmitter into one section alone. If it becomes necessary to place a transmitter into service when either section is removed, the jumper assembly supplied with each cabinet provides a quick means of connecting the transmitter directly to the antenna. This jumper shorts the input terminal to the output and should only be handled when the transmitter power is off.

TABLE 3-10. FREQUENCY COVERAGE CHART FOR FILTER ASSEMBLIES.

Filter Assembly Electrical	Filter Subassembly	Frequency Range	
		Position 1	Position 2
F-159/SRT	F-173/SRT	Below 352 kc	Below 400 kc
	F-174/SRT	Above 400 kc	Above 450 kc
F-160/SRT	F-175/SRT	Below 1500 kc (no switch)	
	F-176/SRT	Above 2000 kc (no switch)	
F-161/SRT	F-177/SRT	Below 3025 kc	Below 3500 kc
	F-178/SRT	Above 3500 kc	Above 4030 kc
F-162/SRT	F-179/SRT	Below 6040 kc	Below 7000 kc
	F-180/SRT	Above 7000 kc	Above 8050 kc
F-163/SRT	F-181/SRT	Below 12.1 mc	Below 14.0 mc
	F-182/SRT	Above 14.0 mc	Above 16.15 mc

Filter Assembly, Electrical F-160/SRT is not equipped with a switch and the switch actuator mechanism serves no purpose. The frequencies above which and below which this unit is operated are fixed.

The transmitters are adjusted in the conventional way and may be loaded into the antenna separately or simultaneously. One of the main features of this

equipment is the absence of interaction between transmitters even though they are used with one filter assembly and load into the same antenna.

The inspection door on the front of each filter subassembly may be used for visual inspection of the unit while it is in operation. No attempts should be made to service or adjust units while the power is on.

## SECTION 3-5

### INSTALLATION OF AUXILIARY EQUIPMENT

#### 1. THREE-INCH COAXIAL TRANSMISSION LINE

a. GENERAL. - A three inch coaxial ~~transmission~~ line is used with transmitter antenna runs in certain multicoupler installations. This line has been given the designation of RG-162/U. The details of this line are shown in Figures 3-20, 3-21, 3-22, 3-23, 3-24 and 3-25.

The RG-162/U coaxial transmission line consists of an inner and outer conductor. The inner conductor is concentrically supported within the outer conductor by Teflon spacers placed 18 inches apart. Straight lengths of the line are normally supplied in 10 and 20 foot lengths. Flanges, 90° and 45° bends, bulkhead flanges and end seals are available for use with the straight sections. Solderless expansion type inner conductor connectors are also available for joining lengths of the inner conductor.

The 10 and 20 foot straight sections of line are supplied with universal couplings at both ends and at only one end. The coaxial line flange assembly is used with the straight line sections having a universal coupling at one end only. This provides a means of obtaining straight

line sections of various lengths up to 20 feet.

The 90° and 45° bends are supplied with universal couplings at both ends.

The bulkhead flange assembly provides a watertight fitting around the outer conductor of the RG-162/U line as it passes through a bulkhead.

The end seal provides a pressure-tight fitting at the end of the line as well as a means of attaching the antenna lead-in. There is also a pressure inlet on the end seal to provide for pressurizing the line if desired.

Indiscriminate use of 3-inch coaxial line is not feasible. This line will not accept standing waves of a large magnitude without breakdown. Mismatch at the antenna will create standing waves and excessive voltages. However, this line does have many good qualities when properly used.

#### b. CHARACTERISTICS

- (1) CHARACTERISTIC IMPEDANCE:  
175 ohms
- (2) OUTSIDE DIAMETER:  
3.125 inches

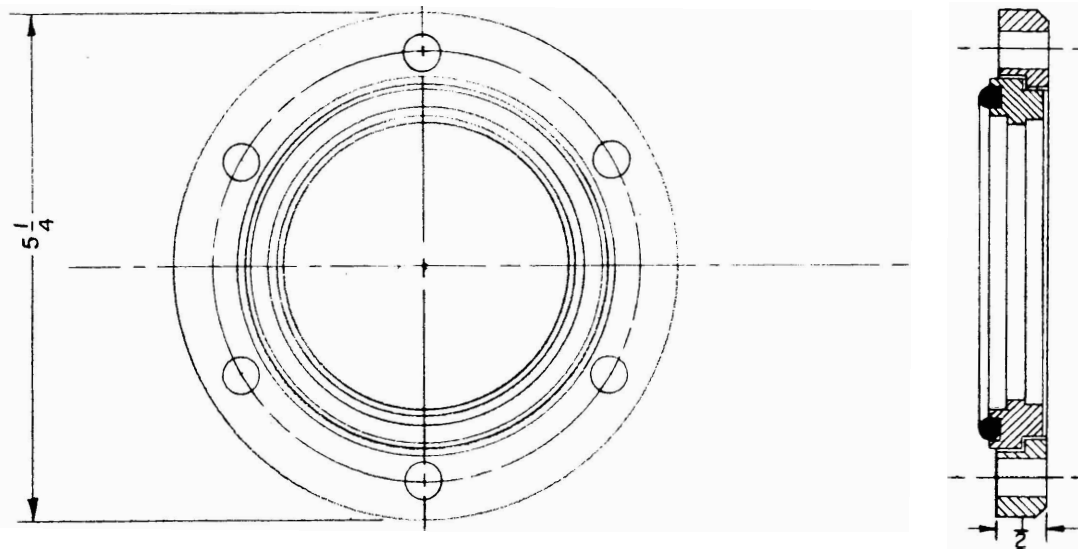

HARDWARE			
QTY	PART	TYPE	MATERIAL
6	BOLT	3/8-16 HEX HD 1-1/2 LG	STAINLESS STEEL
3	LOCKWASHER	3/8	STAINLESS STEEL
3	NUT	3/8-16 HEX HD	STAINLESS STEEL
1	GASKET	O-RING	NEOPRENE

Figure 3-20. Flange Assembly, Waveguide Type UG-1087/U

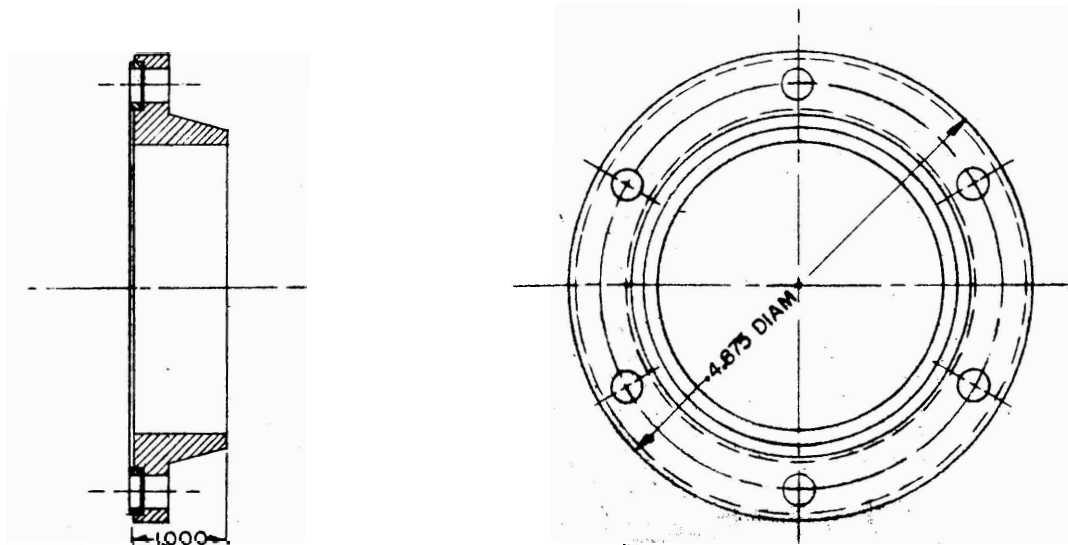

HARDWARE			
QTY	PART	TYPE	MATERIAL
6	BOLT	5/16-18 HEX HD 3 LG	STAINLESS STEEL
6	LOCKWASHER	5/16	STAINLESS STEEL
6	NUT	5/16-18 HEX HD	STAINLESS STEEL
1	GASKET		COPRENE

Figure 3-21. Bulkhead Flange, MX-1599/U

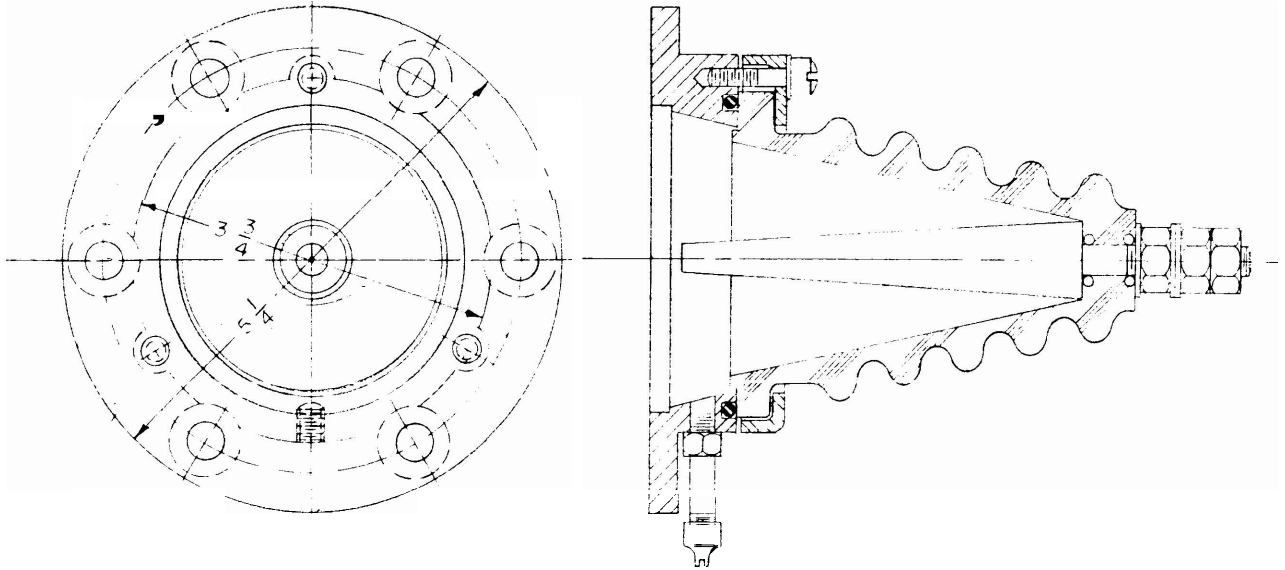

HARDWARE			
QTY	PART	TYPE	MATERIAL
3	BOLT	3/8-16 HEX HD 1-1/2 LG	STAINLESS STEEL
3	BOLT	1/4-20 FIL HD 1 LG	STAINLESS STEEL
3	LOCKWASHER	3/8	STAINLESS STEEL
3	LOCKWASHER	1/4	STAINLESS STEEL
3	FLATWASHER	3/8	BRASS
3	NUT	3/8-16 HEX HD	STAINLESS STEEL
3	NUT	3/8-16 HEX HD	BRASS
2	GASKET	O-RING (AN-6227B-7)	NEOPRENE
1	GASKET	O-RING (AN-6230B-12)	NEOPRENE

Figure 3-22. 3-1/8 -175 Ohm End Seal, Type MX-1598/U

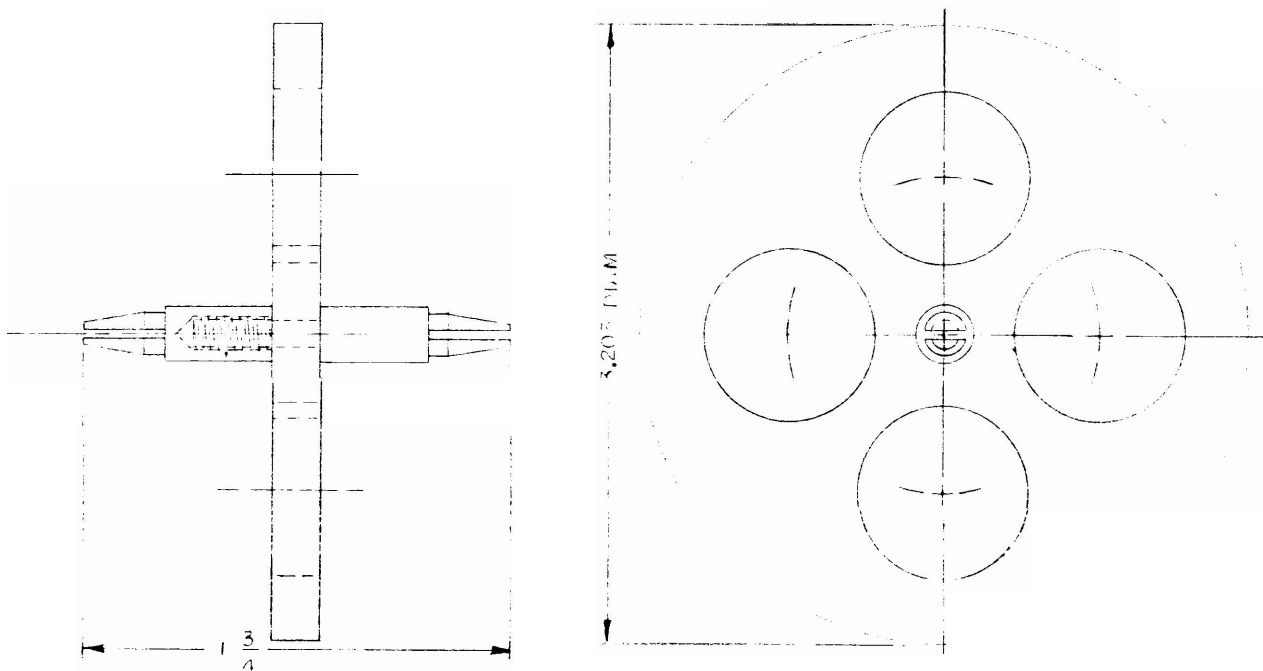

Figure 3-23. Inner Conductor Connector, Type MX-1600/U

(3) INSIDE DIAMETER:  
3 inches

(4) INNER CONDUCTOR:  
0.156 inches

(5) SPACING, TEFLON SPACERS:  
18 inches

c. INSTALLATION. - When installing this line care should be exercised in order that the line will not be dented as electrical losses result from dents. Also use care to prevent dirt, dust and other foreign material from entering the line.

When long lengths of line are used it should be supported every 5 feet.

For complete details of installation of RG-162/U transmission line refer to NAVSHIPS 900, 171, Chapter 11, RIGID R F TRANSMISSION LINES, pages 11-83 through 11-83H.

## 2. ANTENNAS

a. GENERAL. - The use of multicouplers has improved shipboard antenna systems by reducing the number of antennas required. This not only permits maximum use of the best available antenna sites, but also reduces intercoupling between antennas.

An antenna that is to be used with multicouplers must be capable of handling simultaneous transmissions from several transmitters without serious loss of power in the multicoupling equipment. The antenna must also function satisfactorily over a wide band of frequencies. This broad-band operation is a practical necessity at frequencies where the transmission line losses are high.

The effectiveness of a given antenna system is more dependent upon favorable impedance transformations than upon line losses. If the antenna offers a good impedance match to the transmission line throughout the band, the power transfer and efficiency of the entire system will be improved.

Broad-band antennas are recommended for use with antenna multicouplers wherever possible. Antennas of this type which appear suitable for shipboard installation include the inverted pyramid

or cone, the trussed whip and the sleeve antenna.

b. SLEEVE ANTENNAS. - The sleeve type of broad-band antennas have several desirable characteristics when used in the high frequency band for shipboard installations. In general, sleeve antennas, considered for broad-band usage, are superior to single wire or whip antennas. They are superior both in vertical pattern and impedance characteristics to a normal vertical antenna fed against ground.

The impedance characteristic of sleeve antennas are such that satisfactory standing wave ratios can be obtained over a wider frequency range. Generally, antenna patterns taken in the vertical planes are superior in that nulls are not so deep and radiation at low angles is much greater.

For further information on the vertical patterns and impedance characteristics of cylindrical sleeve antennas, refer to NRL Reports R-3354 and R-3411.

A sleeve antenna consists of a lower portion called the sleeve and an upper portion, called the upper radiator, which is insulated from the lower portion. The sleeve is grounded on one end and the feed point is between the top of the sleeve and the bottom of the upper radiator.

The impedance characteristics of sleeve antennas may be varied over a wide range by varying the diameter of the upper and lower sections, as well as the ratios of the length of the upper section to the length of the lower section.

Two of the sleeve antennas developed for use on the USS Northampton (CLC-1) are shown in Figure 3-26. These broad-band antennas operate over a 3 to 1 frequency range. They are used in conjunction with HF multicouplers so that several equipments may be operated simultaneously on the same antenna. 50-ohm coaxial lines will connect each multicoupler to its associated antenna. At the base of the antenna the 50-ohm line will connect to an impedance transforming section located inside the sleeve. This transformer section will terminate

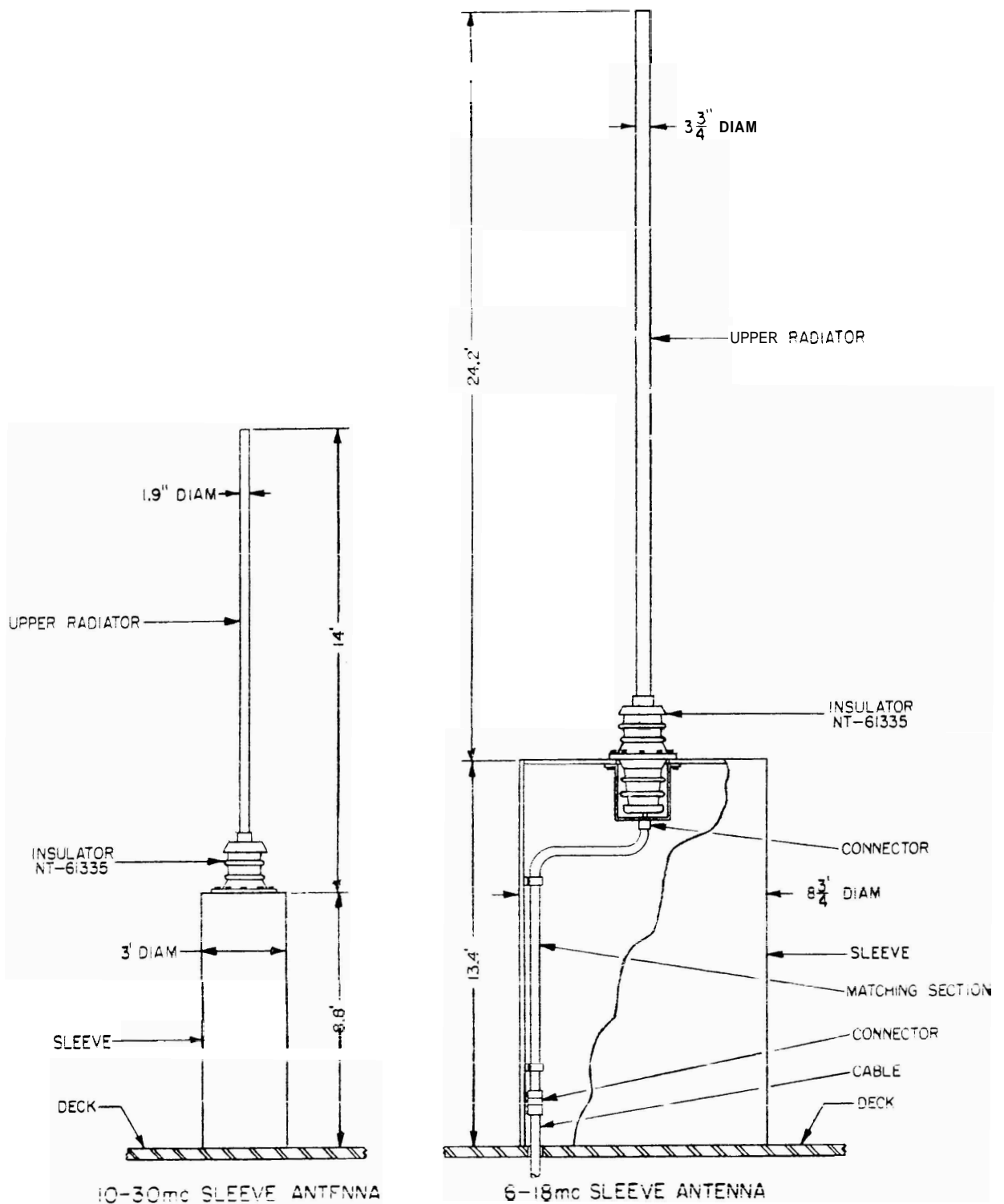

Figure 3-26. Sleeve Antennas Designed for the CLC-1

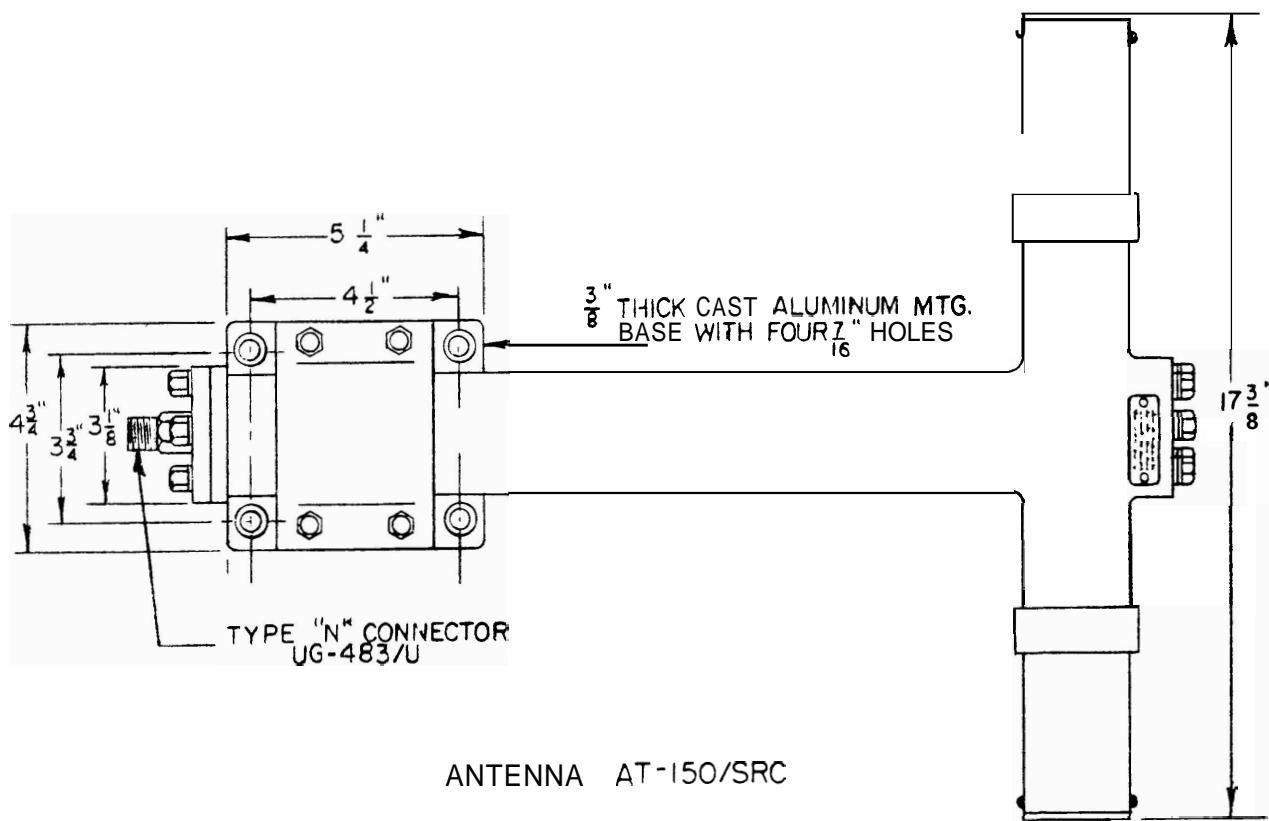
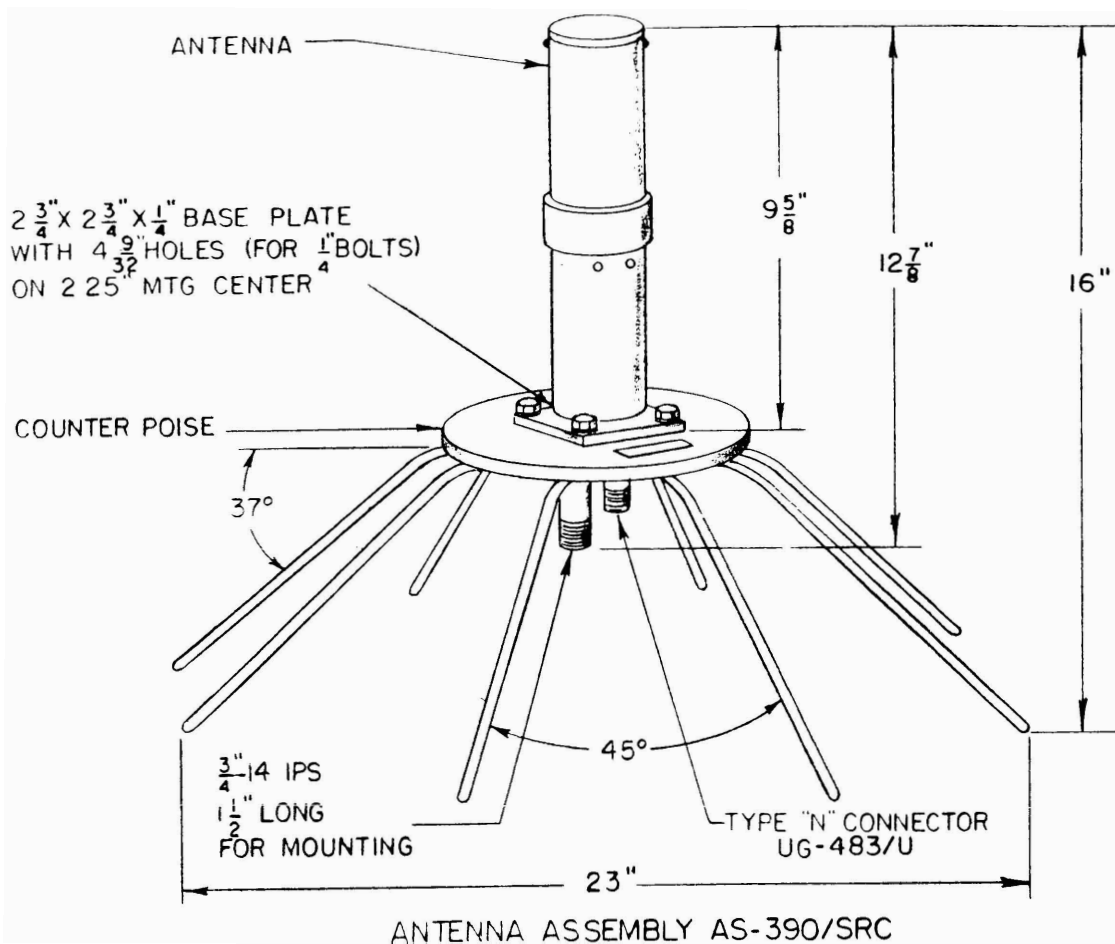

Figure 3-27. Broad-band UHF Antennas



in a fitting at the base of the upper radiator from which a short connection will be made, either through a small inductance, or directly to the upper radiator.

The design of the impedance transforming sections will be determined from measurements taken after the sleeve antennas have been installed on the ship.

c. UHF ANTENNAS. - Two broad-band antennas have been developed for use in all shipboard UHF installations. They may be used for transmitting or receiving vertically polarized waves in the frequency ranges of 220 to 400 megacycles. The outline and mounting dimensions for these two antennas are shown in Figure 3-27.

Antenna AT-150/SRC is a broad-band coaxial dipole. It is balanced with respect to ground and has a nominal input impedance of 52 ohms. The voltage standing wave ratio will not exceed 2.1 to 1 over the designed frequency range. The horizontal, non-radiating portion of the antenna acts as a mounting arm and houses the antenna feed line. A copper tube is short-circuited to the RG-81/U coaxial feed line making a balun arrangement which serves to apply equal and opposite potentials to both sections of the radiating portion of the antenna. The vertical portion of the antenna forms the radiating element and is made up of an inner coaxial line and outer coaxial line. The antenna must be mounted with the radiating element in the vertical position by using the antenna clamp and mount for attachment to a mast, yard-arm or similar structure.

Antenna Assembly AS-390/SRC is a broad-band coaxial stub antenna. It has a nominal input impedance of 52 ohms and is unbalanced to ground. The voltage standing wave ratio will not exceed 1.9 to 1 over the designed frequency range. This antenna has a radial type ground plane consisting of a round plate and eight equally spaced rods bent downwards at an angle of 37 degrees. This antenna is provided with a short length of threaded pipe for mounting. It should be mounted vertically, high enough to clear all obstructions.

50-ohm transmission lines are used with these antennas. Use either an RG-18/U cable with a UG-982/U connector, or an RG-10/U cable with a UG-941A/U connector.

In general, the AS-390/SRC antennas should be installed on top of a mast or pigstick and the AT-150/SRC antennas should be installed at the end of the yard-arms.

It must be remembered that both of these antennas have their feed lines short-circuited internally. Normally, the DC resistance is zero between antenna section and both terminals of the input connector. If it is desired to megger the transmission lines feeding these antennas, it will be necessary to disconnect the antennas from the lines before measuring the insulation resistance.

If further information on these antennas is desired, consult the instruction book NavShips 91338.

d. MODIFIED WHIP ANTENNA. - It is possible to modify a narrow-band antenna such as a whip so that it will function satisfactorily in a multicoupler installation.

From the standpoint of reflection losses, it would be ideal if the antenna were purely resistive. With a narrow-band antenna, such as a thin wire or whip, this condition can be approximated only at frequencies near resonance. The impedance characteristics of narrow-band antennas match 175 ohm lines and filters reasonably well at the higher frequencies, but tend to cause reflections at the lower frequencies. The use of an antenna tuning unit will improve the impedance matching. In this manner, the performance of the antenna at the low frequencies is improved without materially affecting performance at the high frequencies. Figure 3-28 illustrates such an installation. The position and details of the whip antenna may vary.

e. MINIATURE RECEIVING ANTENNA AN/SRA-10(XG-1). - As an alternative to receiver multicoupling, the miniature antenna was developed to eliminate the problem of interaction between large, closely-spaced antennas.

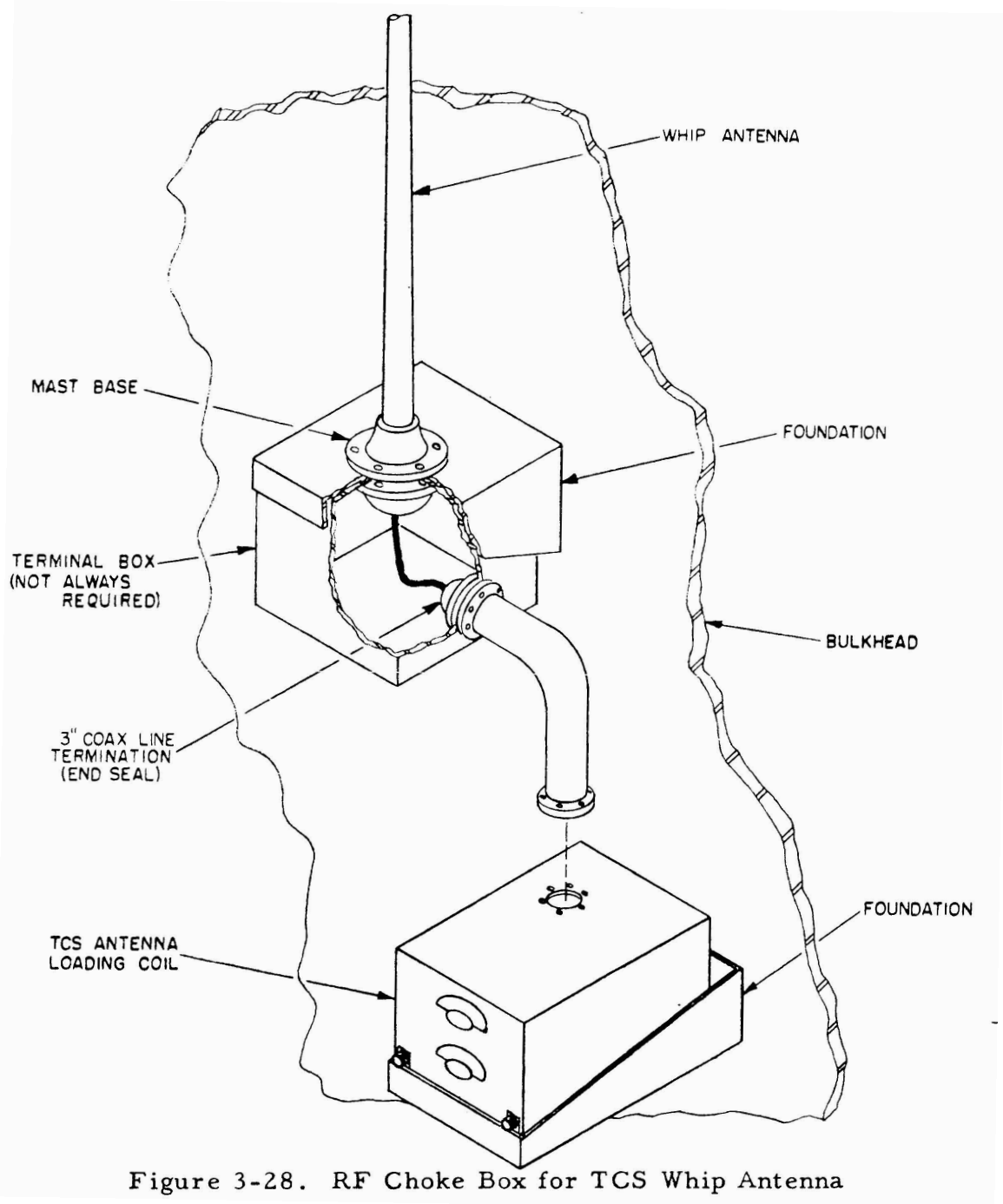

Figure 3-28. RF Choke Box for TCS Whip Antenna

If a very small antenna is used with a receiver, it can be expected that some signal will be collected. However, such a small amount of energy will be collected that something must be done to prevent complete loss of signal due to mismatch conditions. In the AN/SRA-10(XG-1) a Remote Tuner Unit which is a tunable cathode-follower circuit is installed in the base of the antenna. This provides a means of matching between the antenna and the transmission line

and reduces losses so that a useable signal reaches the receiver.

The advantages are obtained by the use of AN/SRA-10(XG-1) miniature antennas. First, by installing the antennas at a point well up in the superstructure and using shielded coaxial transmission lines the pick-up of ship-generated noise is lessened to a large degree. Second, because of their small size the degree of mutual coupling between two miniature

antennas is much less than the mutual coupling between larger antennas for the same amount of physical separation.

The disadvantages of a miniature antenna system are: First, each receiver requires a separate antenna. Second, the receiver must be modified which makes it impractical to shift receivers from one antenna to another to take advantage of an antenna with a more favorable radiation pattern. This second disadvantage may be overcome in future development.

The miniature Receiving Antenna AN/SRA-10(XG-1) is a small, top-loaded monopole antenna supported by a standard 12-inch deck insulator. The antenna is connected to a Remote Tuner Unit located directly under the insulator. Signals from the Tuner Unit are fed by an R F transmission line to a modified Model RBC receiver. A Control Unit on top of the receiver enables the operator to change bands and to tune the antenna from the operating position (*see* Figure 3-29).

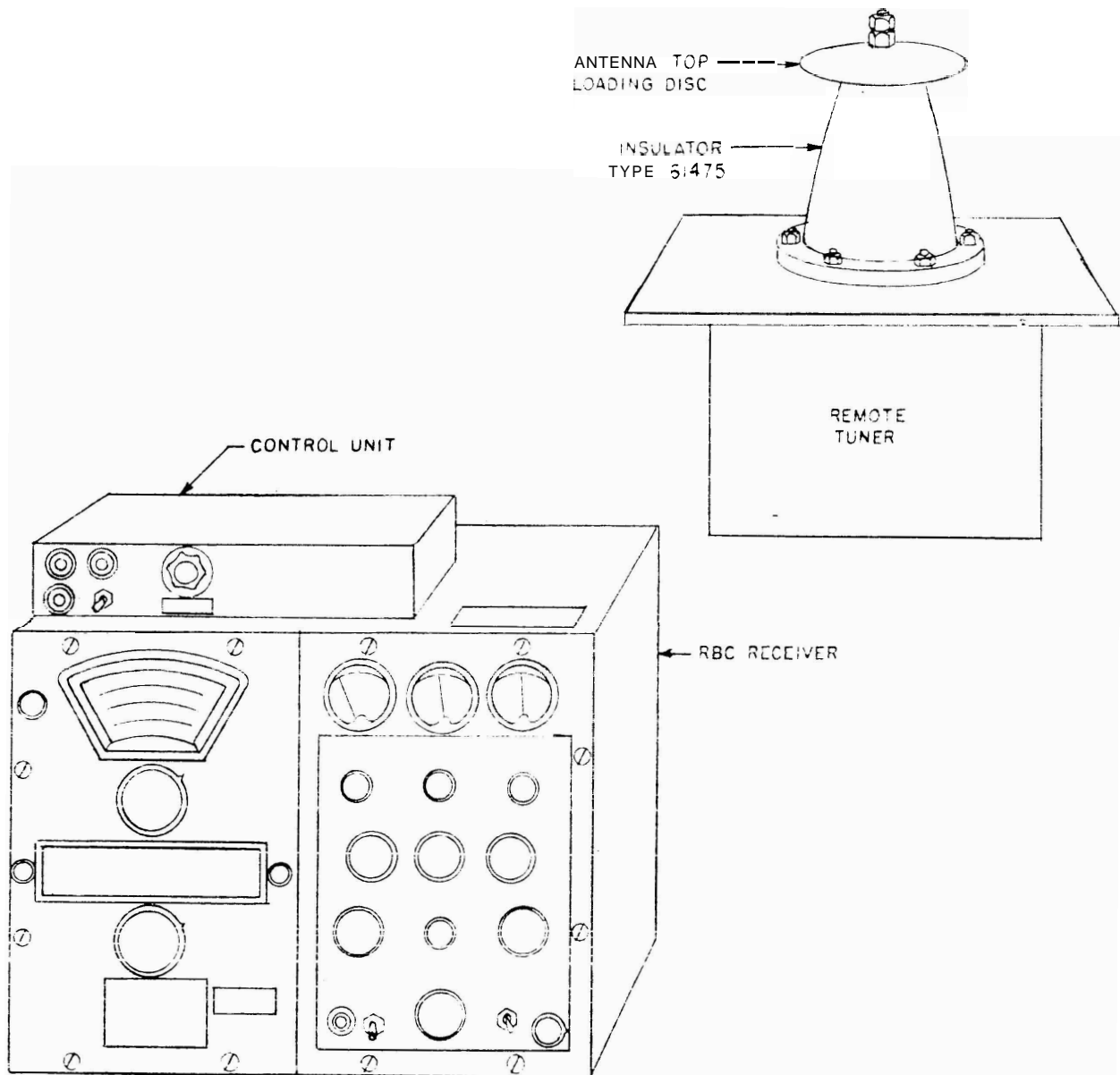

Figure 3-29. Miniature Receiving Antenna AN/SRA-10(XG-1)

The modifications to the Model RBC receiver consist of the addition of mechanical couplings to provide remote tuning and band changing of the antenna as the normal receiver controls are adjusted at the operating position. The modifications do not prevent the use of the receiver with a standard antenna if such use is desired.

This system was designed to cover the frequency range from 4 mc to 27 mc in four bands, the bands coinciding with

those of the RBC receiver.

The complete system operates on 115 volts AC, 60 cycles, single phase.

The AN/SRA-10(XG-1) system consists of the Antenna Unit, a Remote Tuner Unit, and a Control Unit. Table 3-10 lists the overall dimensions and weights of these units.

For further information on these units refer to NavShips 91555, the instruction book for Miniature Receiving Antenna AN/SRA-10(XG-1).

TABLE 3-11. EQUIPMENT SUPPLIED WITH AN/SRA-10(XG-1)

Qty.	Name of Unit	Overall Dimensions (Inches)			Weight (lbs)
		Height	Width	Depth	
1	Antenna Unit	22	18	18	54.5
1	Remote Antenna Tuner Unit	9-1/4	11-1/2	12-1/4	7.0
1	Control Unit	3-1/2	11-1/2	12-1/4	17.5

SECTION 3-6  
RECENTLY (1952) DESIGNED  
RADIO ANTENNA SYSTEMS

1. GENERAL.

With the advent of multicouplers as a part of the shipboard communications system; new antenna systems have had to be designed to operate with these multicouplers. The purpose of this section is to present information on the communications antenna systems designed for two new types of vessels. Since multicouplers are still in a development stage, the systems shown here are not necessarily the ones that will eventually be installed. These systems are included for information only; they are not necessarily typical installations.

It might be helpful to mention here something about antenna transmission lines. Most recent BuShips type plans have shown only two types of RF coaxial cables in the communications antenna system. These two types are RG-10/U and RG-18/U which are both 50-ohm lines. This has been done in an effort to standardize and thereby reduce the number of different types of cables which a vessel will be compelled to carry as spare parts.

There are many reasons for using any particular type of cable as a standard, however, in this case 50-ohm cable was chosen since all vessels will necessarily stock such cables as a repair item for UHF systems. It should be noted that

RG-12/U cable is specified in some of the systems in this section. To go into the reason behind each deviation from the proposed standards would require more space than such detail merits.

These system drawings illustrate the fact that an antenna system for any ship or class of ships should be engineered to obtain the most practical results for that particular installation. The choice of cable should be the result of logical reasoning regarding ultimate result, cost of installation and cost of maintenance. One sample of the type of reasoning necessary when choosing a cable is a system in which AN/SRA-9 Receiving Filter Assemblies are installed. The AN/SRA-9 has an impedance of 180 ohms, the input to the receivers used with this multicoupler is closer to 70 ohms, and the impedance of the antenna will vary greatly throughout the frequency range of the receivers. The most efficient installation from an electronic viewpoint would use a 180-ohm coaxial line. However, Naval Electronics Laboratory, San Diego (designers of the AN/SRA-9) have pointed out that the losses are not appreciable when a 50-ohm line is used. Therefore, it is much more practical and less costly to install RG-18/U, or RG-10/U if the length of the lines are short, rather than to provide a 180-ohm line such as the 3-inch air-filled coaxial line.

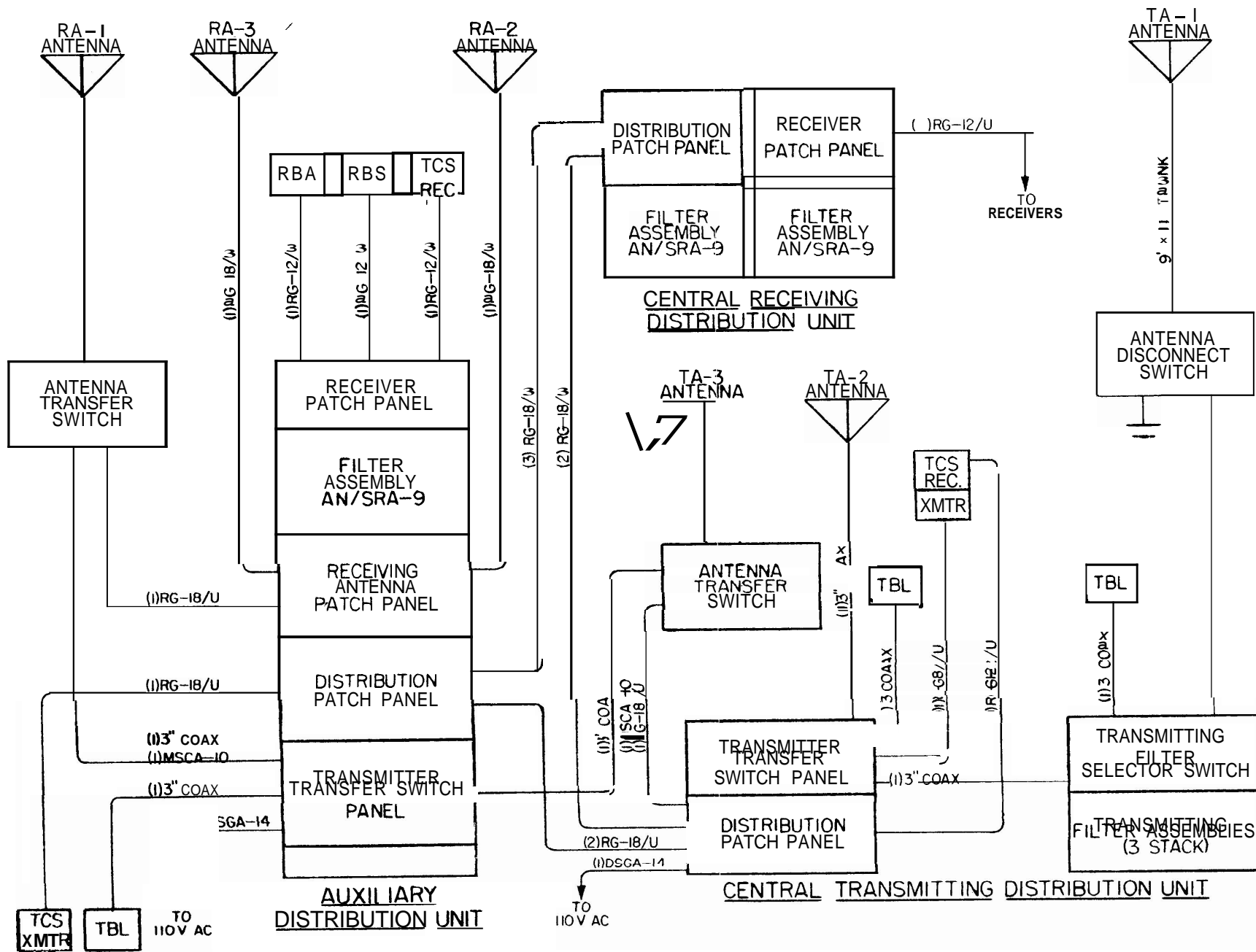

Figure 3-30, Interconnecting Diagram for Multicoupling System on DL-R

ORIGINAL

2. MULTICOUPLER SYSTEM ON THE  
DL-2.

The multicoupling system to be installed on a new vessel, the Destroyer Leader DL-2 is shown in Figure 3-30.

The communications system on this ship uses a minimum number of antennas and is designed for maximum flexibility. There are six antennas used with the multicoupling system: two 35-foot whips and one wire antenna for receiving, and two 35-foot whips and one flat-top antenna for transmitting. The receiving antennas are located forward and the transmitting antennas are located aft so as to provide the best possible isolation between the two types. Provision is made to use any equipment with any of the antennas (except the flat-top) in the event of failure or damage to certain portions of the ship.

This ship uses three AN/SRA-9 receiving filter assemblies. Two located at the central Receiving Distribution Unit and one at the Auxiliary Distribution Unit.

Three transmitting filter assemblies are located at the Central Transmitting Distribution Unit. One of the filter assemblies, F-159/SRT, has a crossover frequency of 375 kc with switching provisions for shifting the crossover frequency to 425 kc; another filter assembly, F-160/SRT, has a crossover frequency of 1750 kc; the third filter assembly, F-161/SRT, has a crossover frequency of 3250 kc with provisions for shifting the crossover frequency to 3750 kc.

The three transmitting filter assemblies are stack-mounted. A four-pole, three-gang, Filter Selector Switch is mounted on the rear of the cabinets. The purpose of this switch is to allow both transmitters to be connected to any one of the three filter assemblies or to allow one of the transmitters to be connected directly to the antenna. This permits more versatile use of the transmitting equipments.

The UHF multicoupling system for the DL-2 is not included in this discussion.

3. MULTICOUPLER SYSTEM ON THE  
CLC-1.

Figures 3-31 through 3-37 illustrate portions of the radio communications system installed on the new Task Fleet Command Ship, USS Northampton (CLC-1). A vessel of this type and size requires a large number of communication circuits. Normally, a correspondingly large number of antennas would be required for these circuits. However, by using antenna multicouplers; the number of antennas required has been greatly reduced.

The multicoupling system on the CLC-1 employs approximately 58 multicouplers and 25 antennas. The receiving antennas are located forward and the transmitting antennas aft to provide maximum isolation between the two types. Note the use of broad-band sleeve type antennas.

a. RADIO TRANSMITTING SYSTEM. - The transmitter multicoupling system for the CLC-1 is illustrated in Figures 3-31 and 3-32. Eight multicouplers are used in this system: three transmitting Filter Assemblies and five HF Multicouplers. Six antennas are used with these multicouplers: five sleeve antennas and one flat-top antenna.

b. RADIO RECEIVING SYSTEM. - The receiver multicoupling system is shown in Figures 3-33 and 3-34. This system uses six AN/SRA-9 Receiving Filter Assemblies. Six antennas are used with these multicouplers: five sleeve antenna; and one wire receiving antenna.

c. UHF SYSTEM. - The UHF multicoupling system for the CLC-1 is shown in Figures 3-35 through 3-37. Forty-four UHF multicouplers are used: twelve CU-255/UR Antenna Couplers and thirty-two CU-332/UR Antenna Couplers. The system employs eleven UHF antennas; three AI-150/SRC dipoles and eight AS-390/SRC stub antennas.

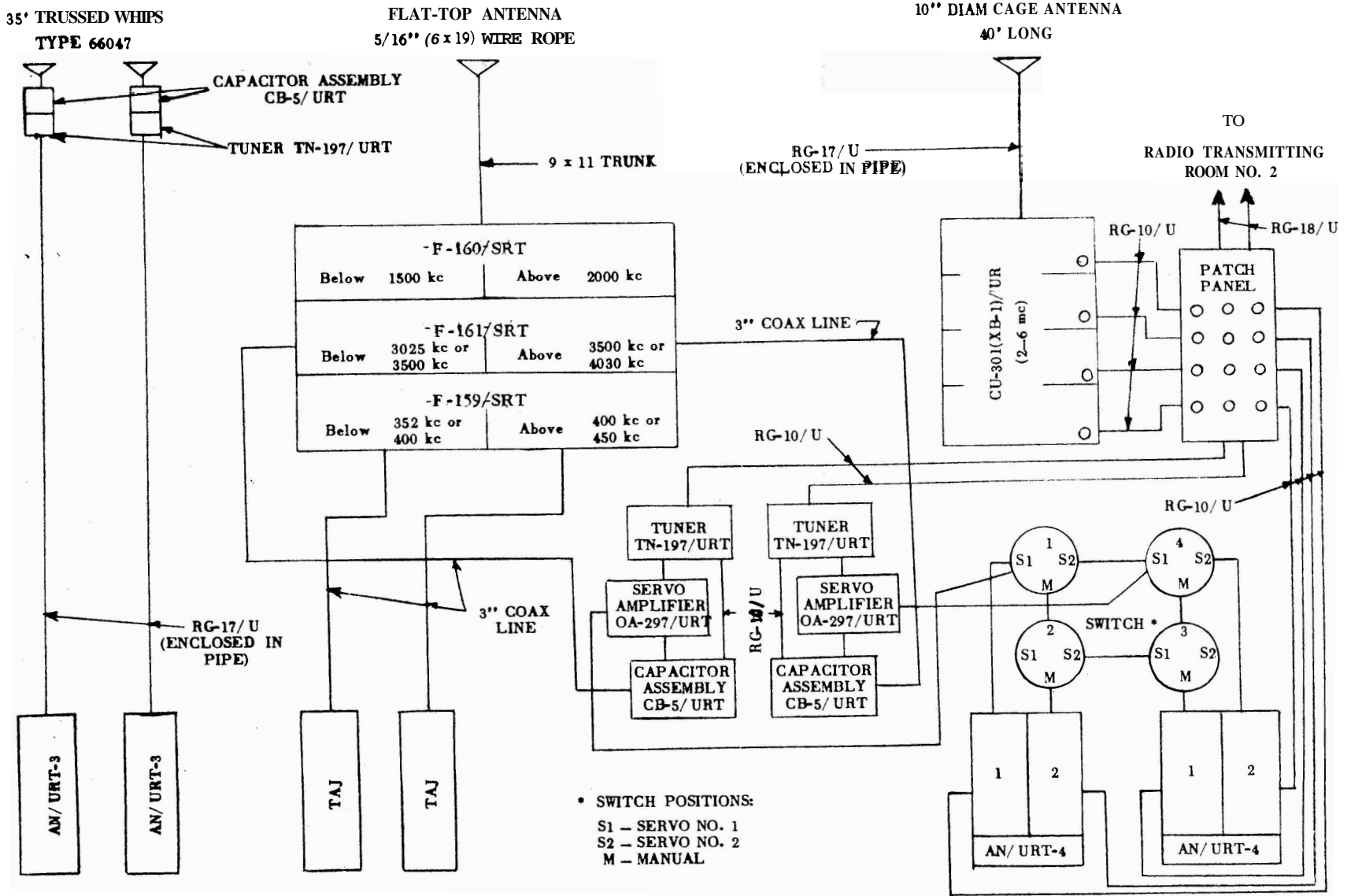
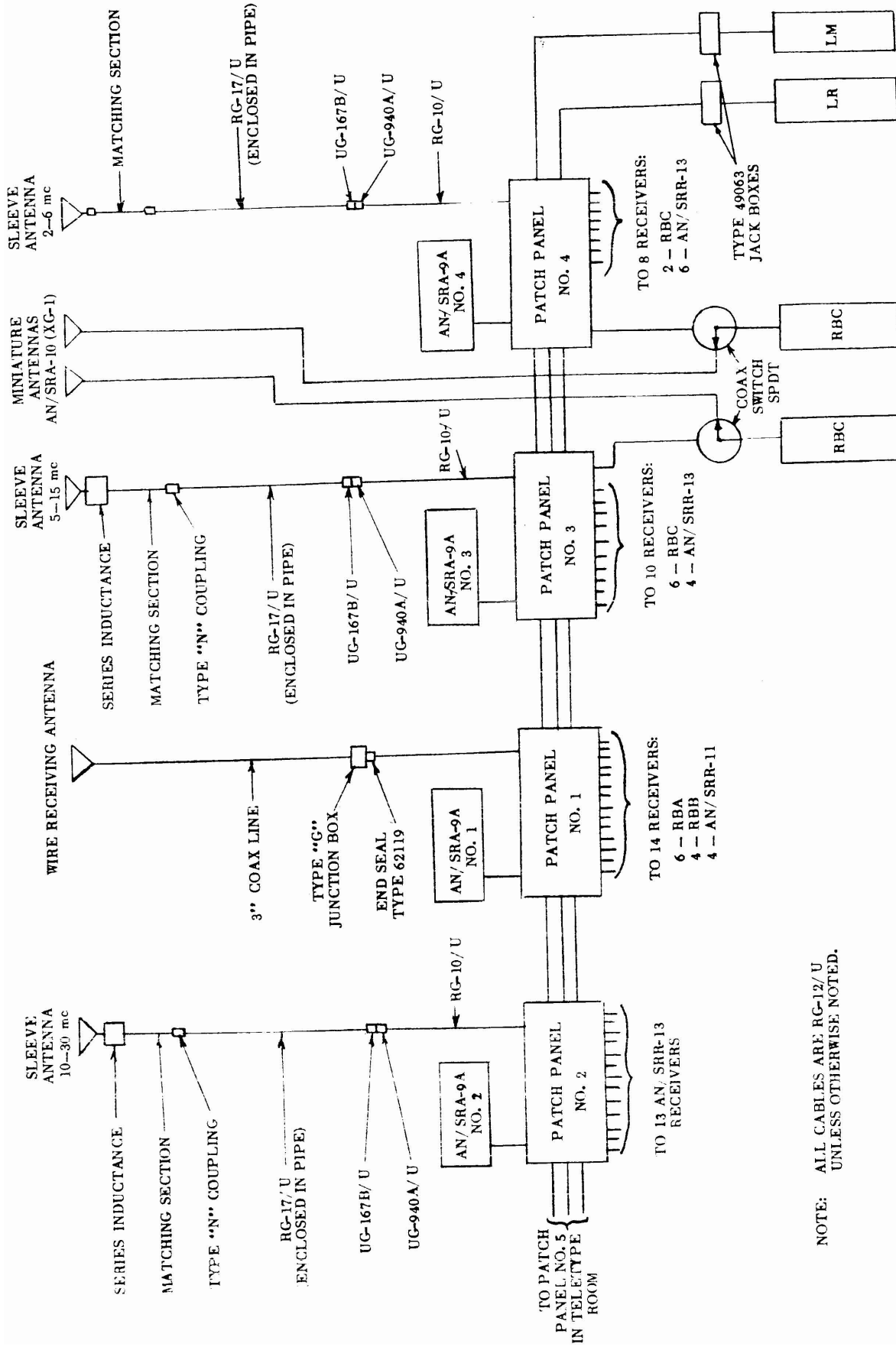

Figure 3-31. Antenna System. CLC-1 - Transmitting Room No. 1





NOTE: ALL CABLES ARE RG-12/U UNLESS OTHERWISE NOTED.

Figure 3-33. Antenna System, CLC-1 - Radio Central

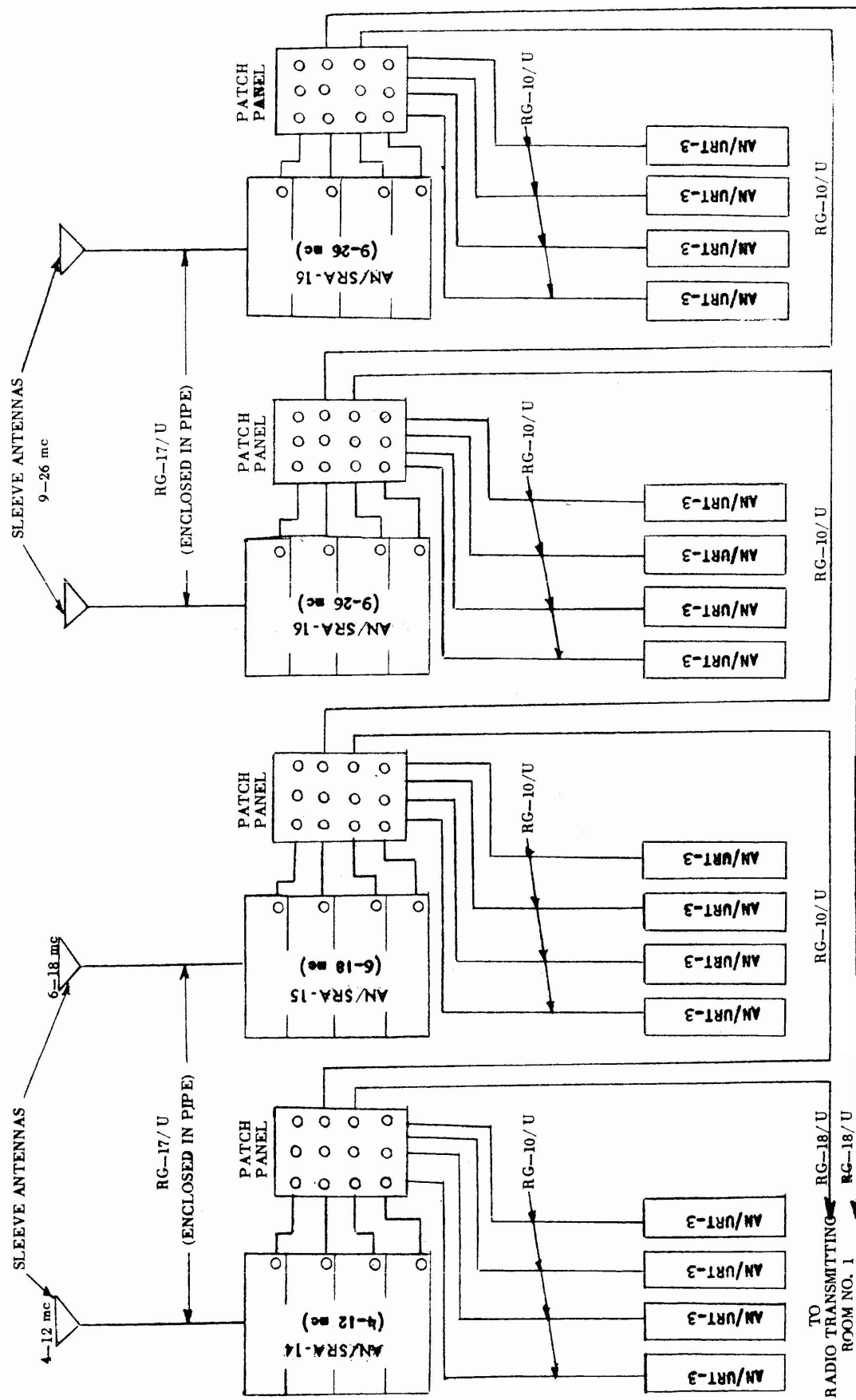
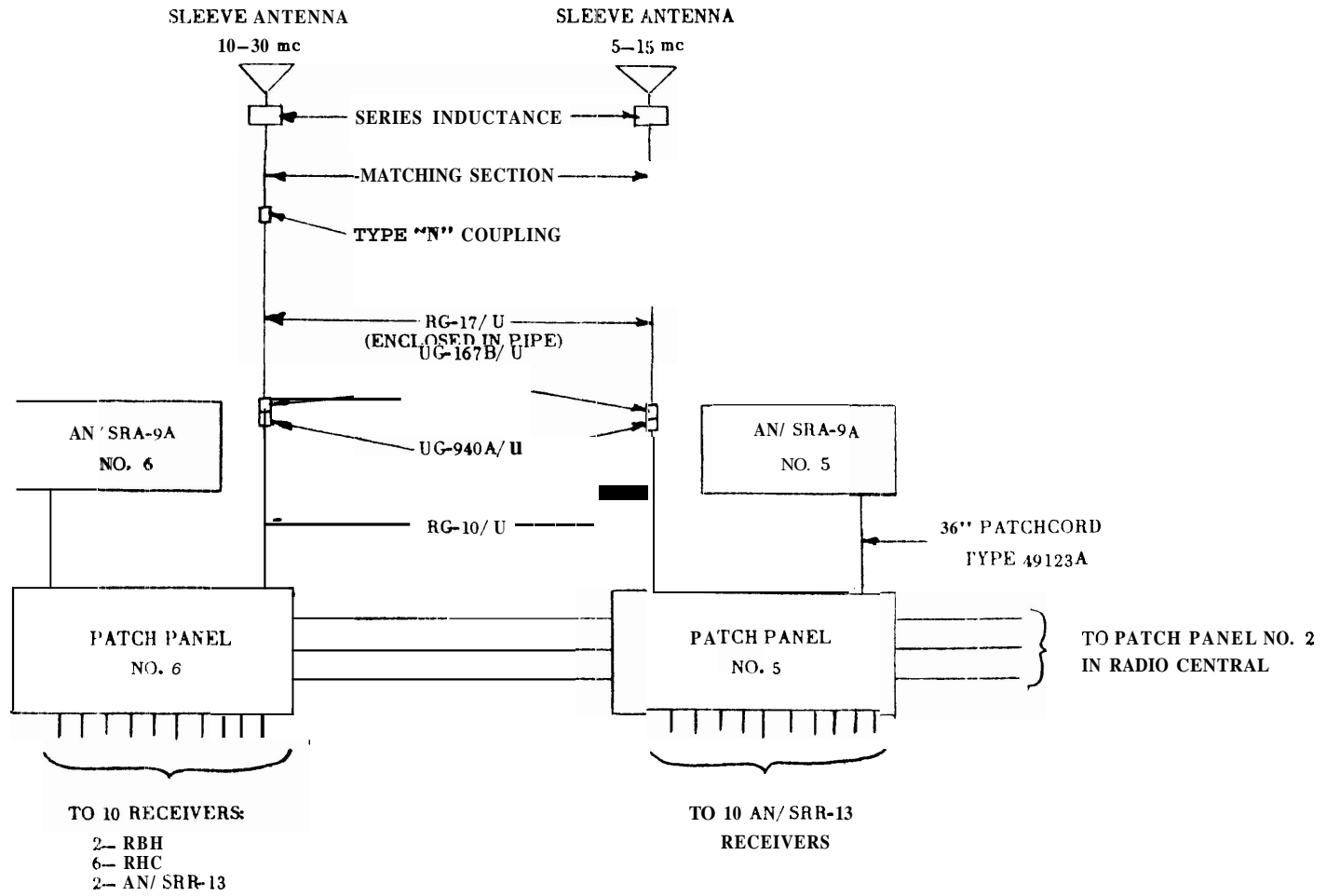

Figure 3-32. Antenna System, CLC-1 - Radio Transmitting Room No. 2



NOTE. ALL CABLES ARE RG-12/U  
UNLESS OTHERWISE NOTED.

Figure 3-34. Antenna System, CLC-1 - Teletype Room

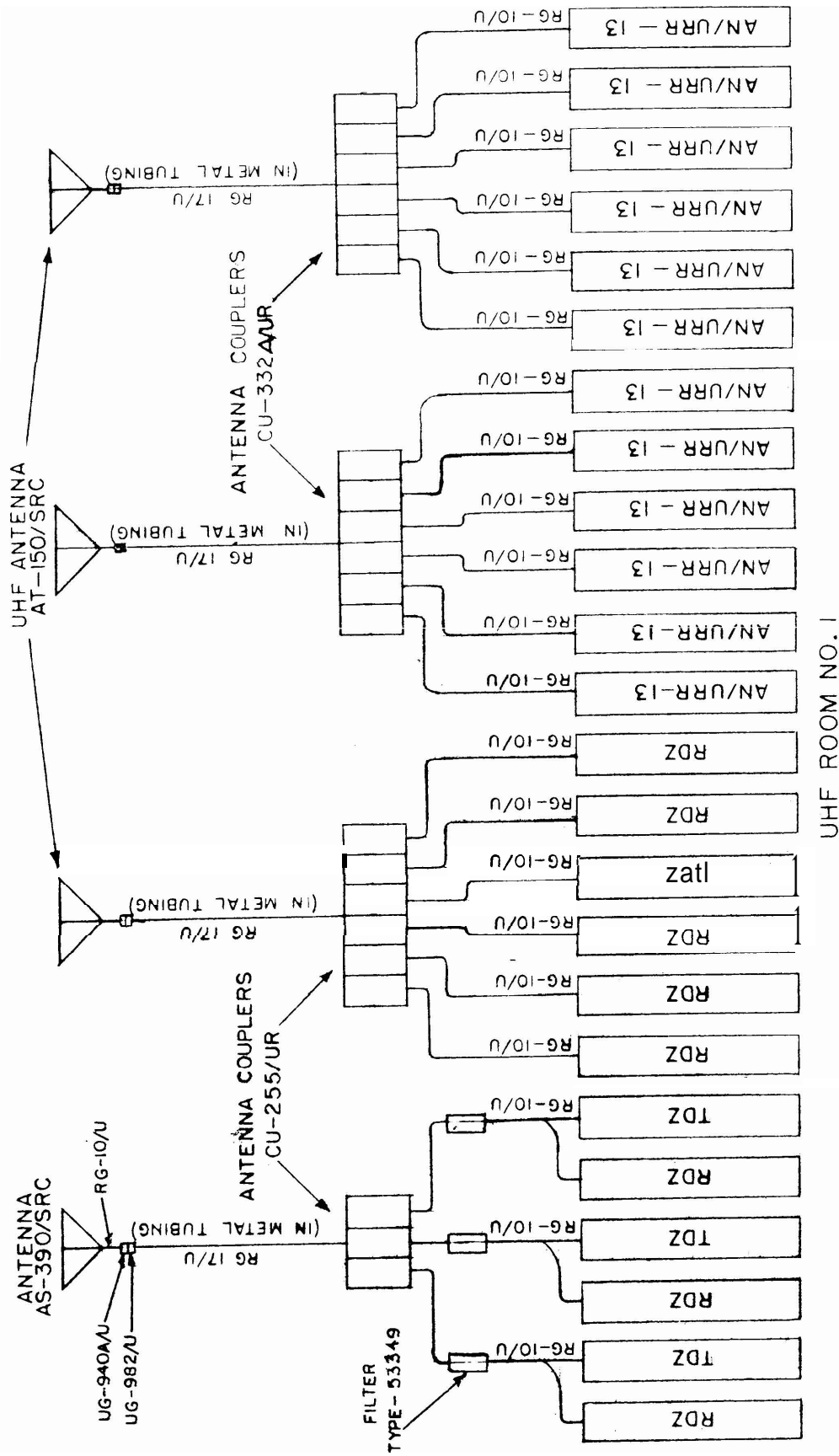

Figure 3-35. Antenna System, CLC-1 - UHF Room No. 1

ORIGINAL

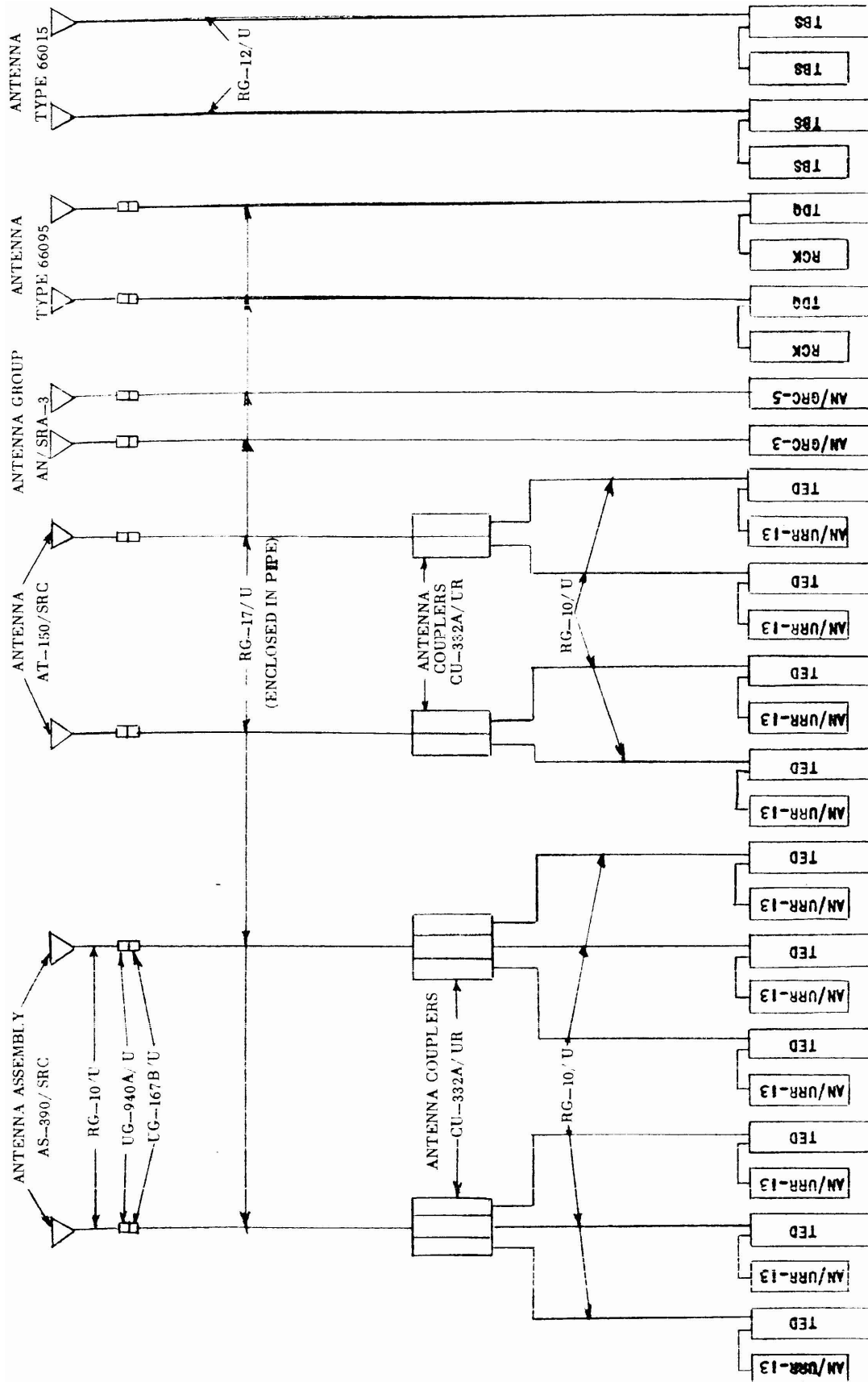

Figure 3-36. Antenna System CLC-1 - UHF Room No. 2



INDEX

Subject	Figure or Table No.	Page
A		
AN/SRA-9A filter assembly.....	3-13	3-23
AN/SRA-9A filter assembly, receiving (See Filter assembly-) .....	.....	.....
AN/SRA-10(XG-1) miniature receiving antenna .....	3-29	3-48
AN/SRA-12 filter assembly, receiving (See Filter assembly-) .....	.....	.....
Antenna assembly AS-390/SRC .....	3-27	3-46
Antenna AT-150/SRC .....	3-27	3-46
AN/SRA-15 antenna multicoupler .....	3-11	3-18
Antenna coupler CU-255/UR .....	3-1	3-2
	3-2	3-3
Antenna coupler CU-274/UR.....	3-7	3-11
Antenna coupler CU-284/UR.....	3-8	3-13
Antenna coupler CU-332A/UR.....	.....	3-8
Antenna coupler CU-355(XN-1)/UR.....	3-9	3-15
Antenna coupler CU-377/UR.....	3-10	3-17
Antennas, installation.....	.....	3-44
Antenna, modified whip.. .....	.....	3-47
Antenna multicoupler AN/SRA-15.....	3-11	3-18
Antenna, receiving, miniature, AN/SRA-10(XG-1).....	3-29	3-48
Antenna system CLC-1.. .....	3-31 to 3-37	3-53
Antenna systems, new (to 1952).....	.....	3-51
Antenna, TCS whip, RF choke box.....	3-28	3-48
Antennas, UHF, broad band.....	3-27	3-47
AS-390/SRC antenna assembly .....	3-27	3-46
AT-150/SRC antenna.. .....	3-27	3-46
Auxiliary equipment, installation.....	.....	3-39
B		
Bulkhead flange Type MX-1599/U.....	3-21	3-40
C		
CG-1177/U and CG-1176/U 3-1/8-175 ohm, 450 and 90° bends line sections.. .....	3-24	3-12
CLC-1 antenna system.....	3-31 to 3-37	3-53
CLC-1 multicoupling system.....	.....	3-53
Coaxial transmission line RG-162/U, assembly.....	3-25	3-43
Conductor connector Type MX-1600/U.....	3-23	3-41
CU-255/UR antenna coupler.....	3-1	3-2
	3-2	3-3
CU-274/UR antenna coupler.....	3-7	3-11

Subject	Figure or Table No.	Page
C		
CU-284/UR antenna coupler.....	3-8	3-13
CU-332A/UR antenna coupler.. ..	.....	3-8
CU-355(XN-1)/UR antenna coupler.. ..	3-9	3-15
CU-377/UR antenna coupler.. ..	3-10	3-16
D		
DL-2 multicoupling system, interconnecting .....	3-30	3-53
E		
Electrical F-145/SRA-9 filter assemblies (See Filter assembly-)... ..	.....	.....
End Seal, 3-1/8-175 ohm, Type MX-1598/U .....	3-22	3-41
F		
Filter assemblies transmitting.. ..	.....	3-33
General description. ....	.....	3-33
Installation. ....	3-18 3-19	3-35
Main Components.. ..	.....	3-33
Operation.....	.....	3-37
Reference data.. ..	.....	3-33
Filter assembly AN/SRA-9A.....	3-13	3-23
Filter assembly, receiving, AN/SRA-9A.....	3-13	3-23
Equipment supplied. ....	3-5	3-23
Filter assembly, Electrical F-145/SRA-9.....	3-14	3-24
General description. ....	.....	3-23
Installation. ....	.....	3-26
Operation.....	.....	3-27
Reference data. ....	.....	3-25
Subassemblies .....	3-6	3-26
Test Set, Filter TS-734A/SRA-9.....	3-13	3-25
Filter assembly, receiving AN/SRA-12.....	3-15 3-16	3-29
General description. ....	.....	3-29
Equipments supplied.....	3-7	3-29
Main components.....	.....	3-29
Subassemblies.....	3-8	3-31
Filter TS-734A/SRA9 test set.. ..	.....	3-25
Filter type multicouplers.....	.....	3-23
Flange assembly, waveguide, Type UG-1087/U.....	3-20	3-40
H		
HF Multicouplers .....	3-4	3-19



Subect	Figure or Table No.	Page
I		
Inner conductor connector, Type MX-1600/U.....	3-23	3-41
M		
Manual drive mechanism.....	3-5	3-8
Multicouplers, filter type.....	.....	3-23
Multicouplers, HF.....	3-4	3-19
Multicouplers, types.....	3-1	3-1
Multicouplers, VHF/UHF.....	.....	3-3
Multicoupling system on the CLC-1.....	.....	3-53
Multicoupling system on the DL-2, interconnecting.....	3-30	3-53
MX-1598/U 3-1/8-175 Ohm End Seal.....	3-22	3-41
MX-1599/U, bulkhead flange.....	3-21	3-40
MX-1600/U, inner conductor connector.....	3-23	3-41
R		
Radio antenna systems, new (to 1952).....	.....	3-51
RDZ installation.....	3-4	3-7
Receiving Antenna, miniature, AN/SRA-10(XG-1).....	3-29	3-48
Receiving filter assembly, AN/SRA-9A (See Filter assembly-).....	.....	.....
Receiving filter assembly, AN/SRA-12 (See Filter assembly-).....	.....	.....
RG-162/U coaxial transmission line, assembly.....	3-25	3-43
RG-162/U, three-inch coaxial transmission line.....	.....	3-39
Installation.....	.....	3-44
S		
Sleeve antennas, installation.....	3-26	3-44
T		
TCS whip antenna, RF choke box.....	3-28	3-48
IDZ-RDZ installation.....	3-4	3-7
TED-AN/URR transmitter-receiver.....	3-6	3-9
Test set, filter, TS-734A/SRA-9.....	.....	3-25
Three-inch coaxial transmission line RG-162/U.....	.....	3-39
Installation.....	.....	3-44
Transmission line RG-162/U, coaxial, three-inch.....	.....	3-39
Installation.....	.....	3-44
Transmitting filter assemblies (See Filter assembly-).....	.....	.....

Subject	Figure or Table No.	Page
U		
UG-1087/U, waveguide flange assembly.....	3-20	3-40
UHF antennas, broad band.. ..	3-27	3-47
UHF multicouplers.....	.....	3-3
V		
VHF multicouplers.. ..	.....	3-3
W		
Whip antenna, modified.. ..	.....	3-47