

CHAPTER 9

PATCHBOARDS AND DISTRIBUTION FRAMES

9.1 GENERAL

Patchboards and distribution frames are standardized at shore stations through the application of the standard plans issued by NAVELEX. These plans designate the type of frame and patchboard required to satisfy each segment of a circuit as it is distributed throughout the communications station. Distribution frames serve as the point of termination for signal and control cabling within the building and for cabling leading to and from the building. Interconnections between the cables are accomplished by "cross-connect" wires that are run between the individual wire terminations of the cables at the frames. The patchboards serve as the access point for operators to monitor the signal carried by individual cable wire pairs and permit operators to reroute circuits and to substitute equipment serving a circuit. Types of equipment, standard terminology, and specific wiring practices for patchboards and distribution frames are discussed below.

9.2 PATCH MODULES

NAVELEX standard plans detail the construction features of the standard circuit patch installation. The three basic patch module types are covered by the following standard plans:

- a. Audio Patch Module, SB-3092A/U, NAVELEX Standard Plan 0100405.
- b. DC Patch Module SB-3189A and B/FGC, NAVELEX Standard Plan 0100449 for large stations and 0100448 for small stations.
- c. General Purpose Multi-Circuit Patch Module, NAVELEX Standard Plan 0100305.

Figures 9-1 and 9-2 depict the standard jack configuration for audio and DC patchboards. These patchboards are packaged as modules containing 26 jack groups that may be used for send or receive circuits. Modular packaging permits acquisition of patchboard equipment only as necessary to meet the existing circuit requirements and makes possible the addition of patchboards as the need arises. The following criteria governs the use of patchboard equipment:

- a. A maximum of four DC operational patch modules may be installed in one cabinet. A fifth module may be added for miscellaneous use when required.
- b. Patchboard modules are to be installed in the upper portion of the cabinet to facilitate use by an operator in a standing position.
- c. The lower portion of a patchboard cabinet may be used for battery supplies or other equipment, such as fuse panels and hubbing units, that require little or no operator attention.
- d. Up to 8 Audio Patch Modules (SB-3092 () may be installed in one cabinet.

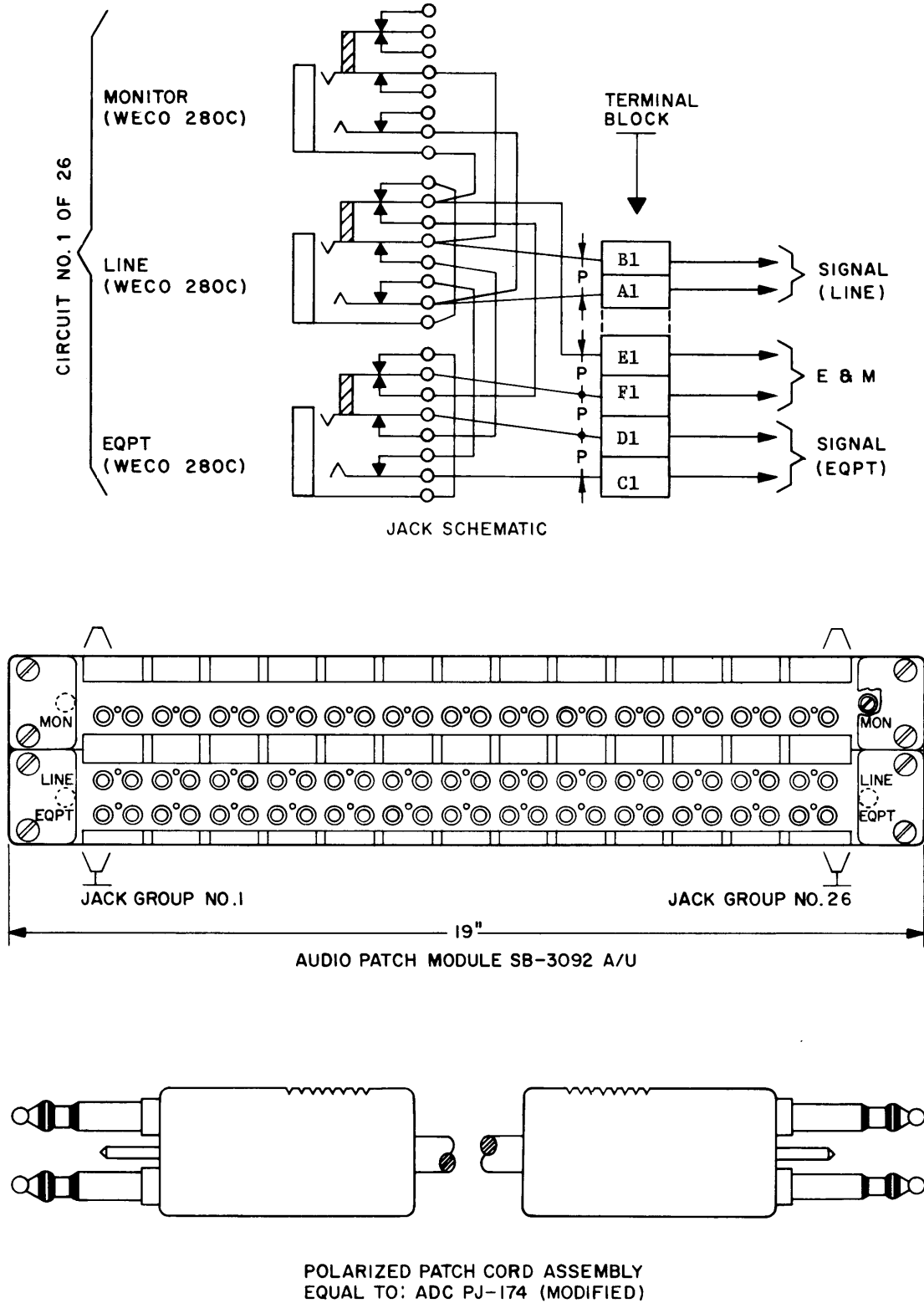
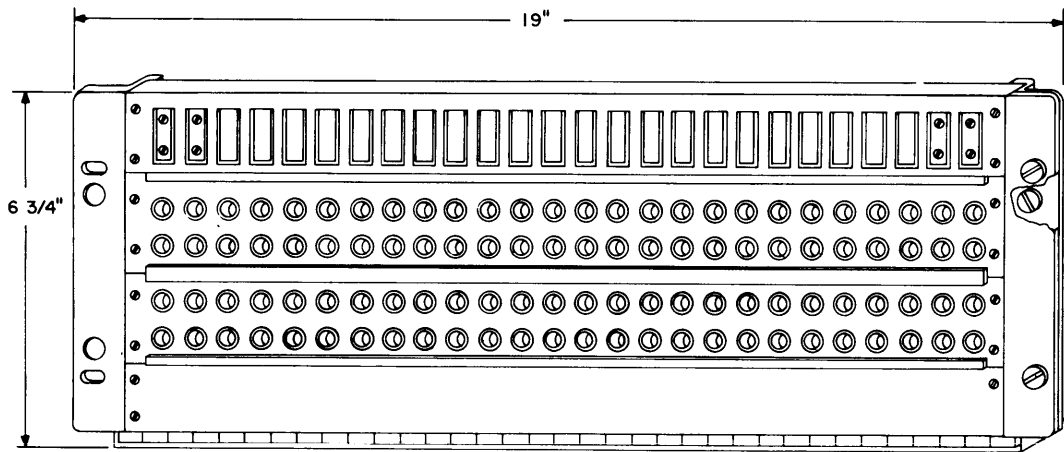
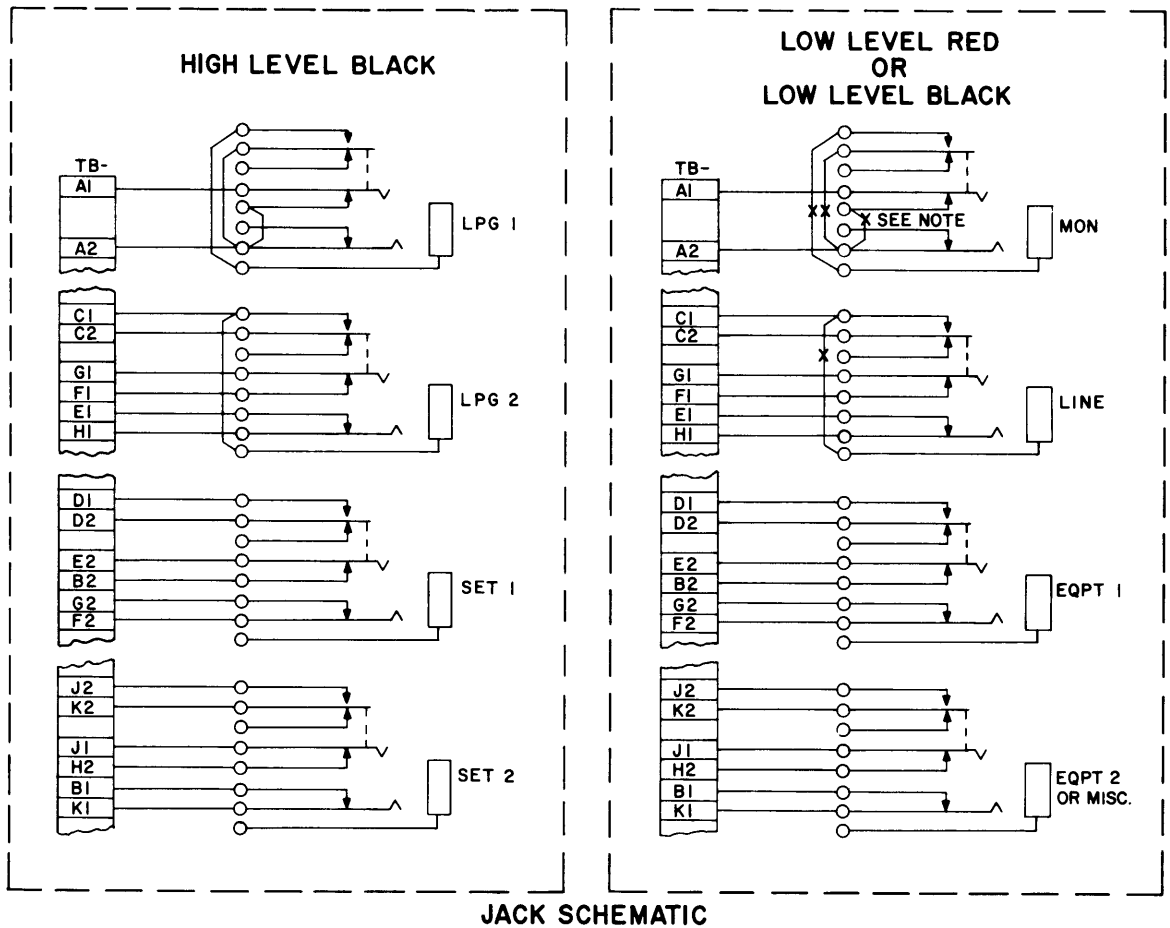

Figure 9-1. Basic Audio Patchboard Module, SB-3092/AU



NOTE:
 PATCH MODULES ARE MANUFACTURED FOR USE IN A HIGH LEVEL ENVIRONMENT.
 THE STRAPS ON THE TWO TOP JACKS MUST BE CUT FOR LOW LEVEL USE.

Figure 9-2. Basic DC Patchboard Module, SB-3189A/FGC

9.3 DISTRIBUTION FRAMES

The communications station employs distribution frames for concentrating individual circuits into cables; these frames serve as the point of equipment interconnection and as the interface point between the outside world and the circuit distribution within the building. Four types of distribution frames may be used within a communications station.

- a. Main Distribution Frame (MDF)
- b. Intermediate Distribution Frame (IDF)
- c. Classified Intermediate Distribution Frame (CIDF)
- d. Combined Distribution Frame (CDF)

Distribution frames are built up of terminal blocks composed of rows of terminals. Each terminal extends through the block so that individual wires of a cable will be terminated on one side of the block and cross-connect wires will be terminated on the opposite side of the block. Frames must be planned so that sufficient room within the frames is available to permit the addition of blocks to support any known expansion requirement.

All blocks used to terminate internal and external cabling are to be positioned vertically within a frame. Horizontal blocks are not to be used on new distribution frames.

Wire termination methods contained in MIL-STD-1130 are approved for distribution frame installation. The wire-wrap method is approved for permanent connections only and may not be used on the cross-connect side of a terminal block. All other terminations on these frames are to be the solder or push-on type. The following types of terminal blocks are approved for use in a distribution frame:

- a. Solder-to-solder connections.
- b. Wire-wrap to push-on.

Wire-wrap to wire-wrap, wire-wrap to solder, and taper pin terminal blocks are not to be used. A wire-wrap to push-on terminal block is shown in figure 9-3. Terminal blocks on which cross-connects must be installed on the same side of the block as the cable terminations are not approved.

9.3.1 Main Distribution Frame

The MDF is to be built up of vertical terminal blocks as illustrated in Figure 9-4. Where double-sided frames are used the rear blocks terminate circuit cables entering the building through fused terminals. Where wall frames or single-sided frames are used the fused protector blocks and the standard terminal blocks must be mounted on the front of the frame. These fused terminals protect inside equipment against excessive external circuit currents. They are also used to terminate the cabling from the intersite link facilities. Vertical blocks are also used to terminate cables that support internal circuit distribution of the building. The MDF is usually located above the external cable entry point, and the external cables are fed up to the frame for individual wire termination. Distribution to locations in the building is accomplished by connecting internal distribution cables to the blocks of the MDF and leading the internal cable up to overhead ducts or trays. All cabling is run on the inner

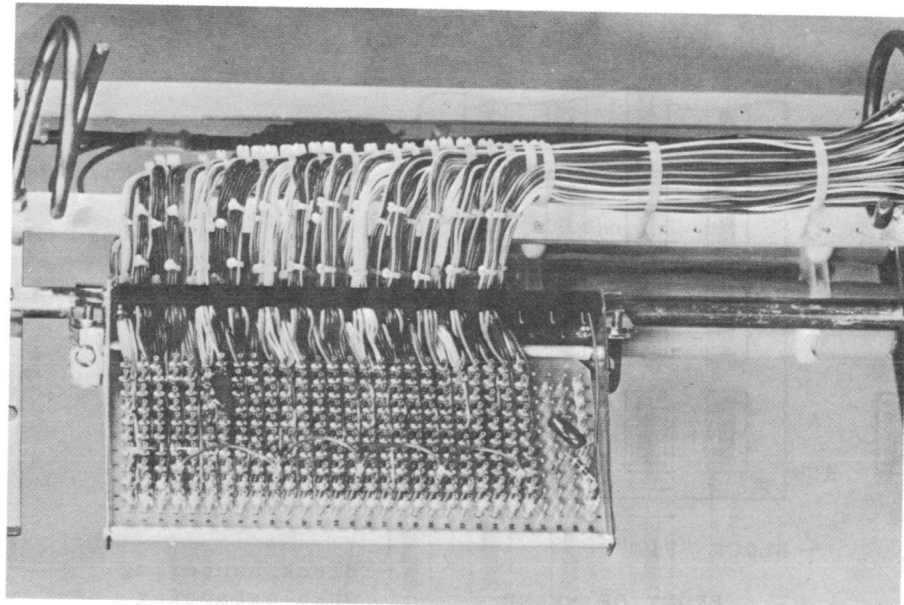

CROSS-CONNECT SIDE

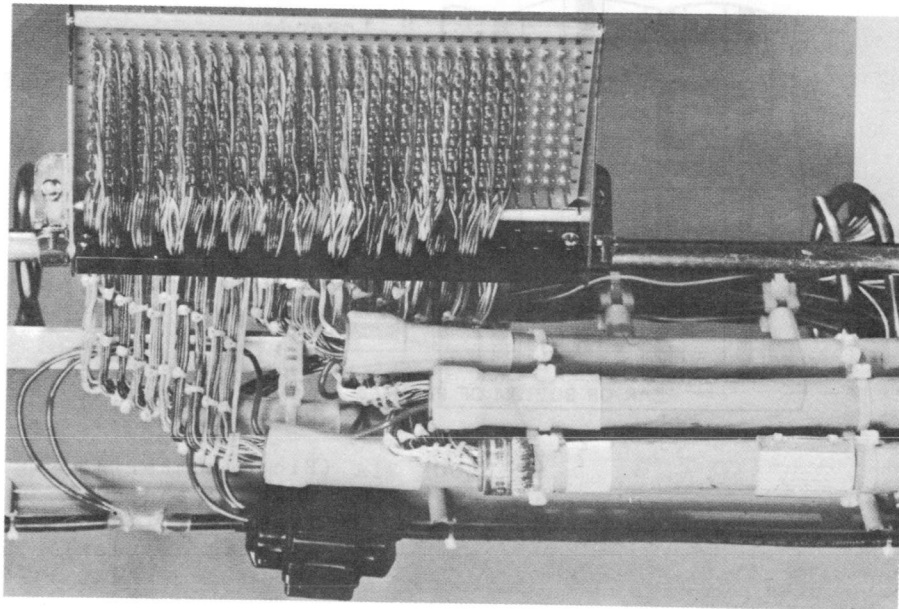

CABLE TERMINATION SIDE

Figure 9-3. Wire Wrap to Push-On Terminal Block

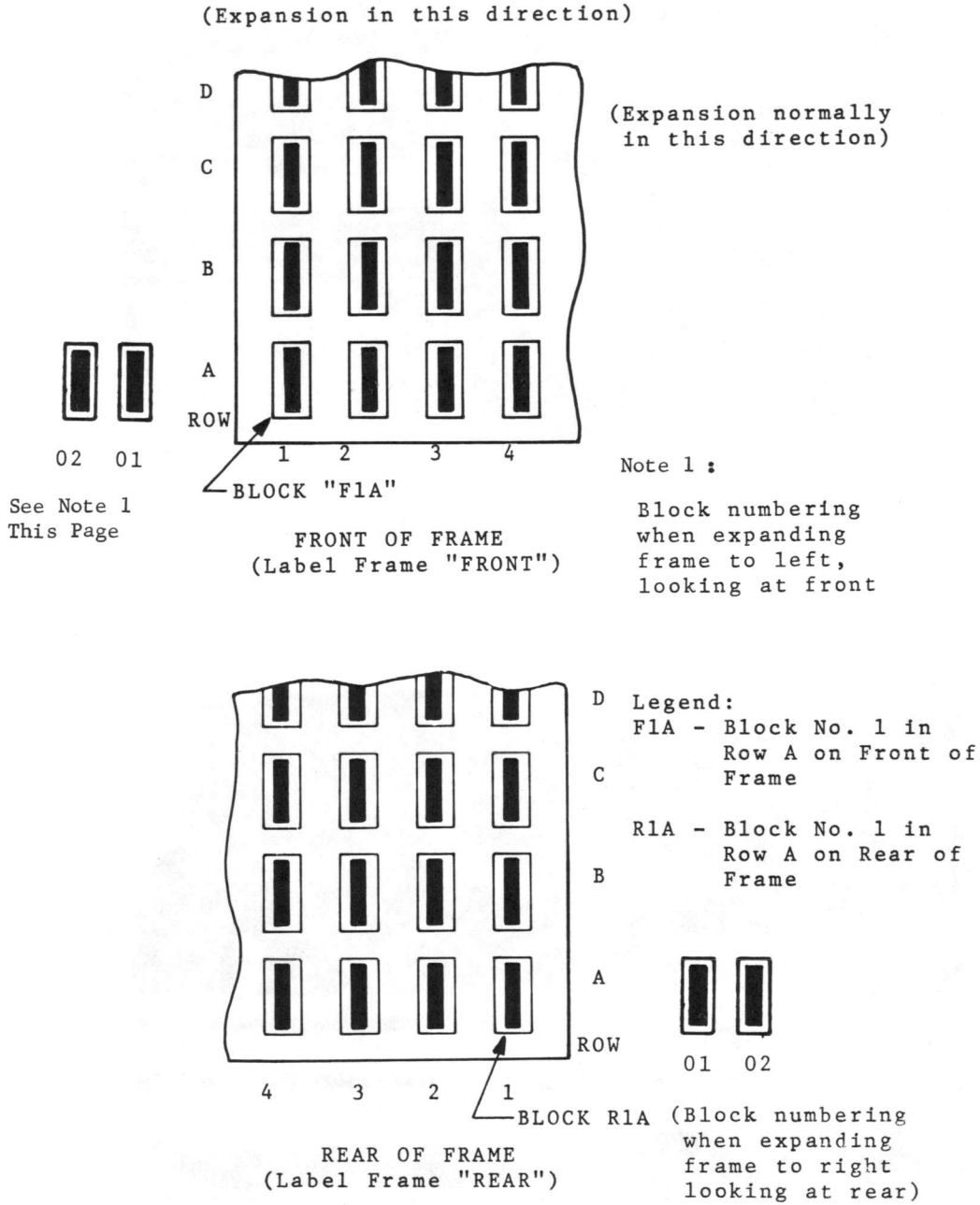

Figure 9-4. Distribution Frame Block Configuration and Designation

portions of the frame, and the individual wires are brought out through the fanning strips of the terminal blocks to the wire termination. The cables are secured to the inner portions of the steel frame to prevent any stress on the wire terminations. Figure 9-5 depicts a typical MDF. Expansion will normally be up and to the right when facing the front of the frame. Figure 9-4 shows block configuration and designation.

9.3.2 IDF and CIDF

The IDF terminates internal distribution cables, equipments, and patchboards that process Black information. The CIDF terminates cables, equipments, and patchboards that process Red information. The IDF should be physically separated from the CIDF by a minimum of two inches; however, it is desirable to locate these units on opposite sides of the room.

These IDF and CIDF frames are composed of rows of terminal blocks mounted in a vertical position. The blocks and the method of laying cable into the blocks are standardized by NAVELEX Standard Plan RW 10F2101. Figure 9-6 shows the solder-to-solder type terminal blocks and wiring plans. The individual cable wires are laid into the block in sequence according to the wire color code for each individual cable. Shields for individual pairs are provided on a special case basis. When shielded pairs are used, the shields are terminated at the intermediate distribution frame in the manner shown in the wiring plan of figure 9-6. (sheet 2 of 4).

The cabling to the blocks is brought to the inner portion of a floor frame with front and back blocks and to the rear of frames with a front block arrangement only. The cabling runs to the frame from the overhead or from the bottom according to the cable distribution system used in the building. In either case the cable is tied to the frame for support to prevent any stress on the wire termination. Typical intermediate distribution frames are shown in figure 9-7.

It is sometimes expedient and practical to route one or more multi-conductor cables from the CIDF or IDF to an equipment room and then connect the multi-conductor cables to smaller cables to form branches leading to the individual equipments. When this is practiced, a "junction box" is used to terminate the cable within the equipment room. The junction box is composed of terminal blocks similar to those used in a distribution frame. This similarity may result in the junction box being mistaken for a distribution frame. However, the junction box can be readily distinguished from a distribution frame by the absence of cross-connect wiring. In a junction box, the smaller cables are connected directly to the back of the terminal block on the terminal corresponding to the front termination of the larger cable. In a distribution frame, cables are interconnected through cross-connect wiring.

9.3.3 CDF

A CDF may be used at small stations, serving the purpose of both the IDF and MDF. When a CDF is used, the blocks that terminate cables and systems that interface with the outside world are to be rear mounted blocks. Blocks used to terminate cables supporting internal distribution are to be front mounted blocks. (See figure 9-4).

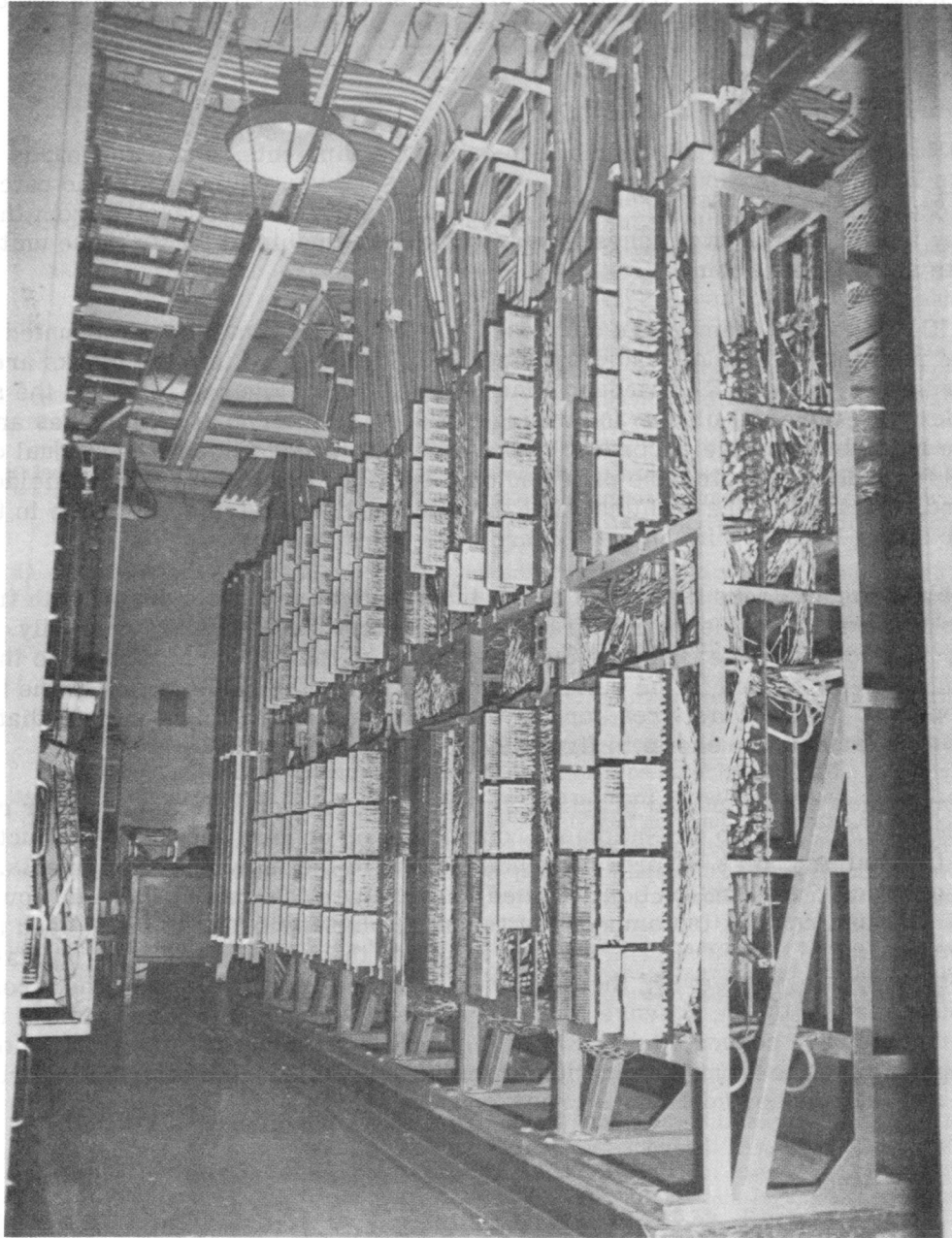

Figure 9-5. Typical Main Distribution Frame

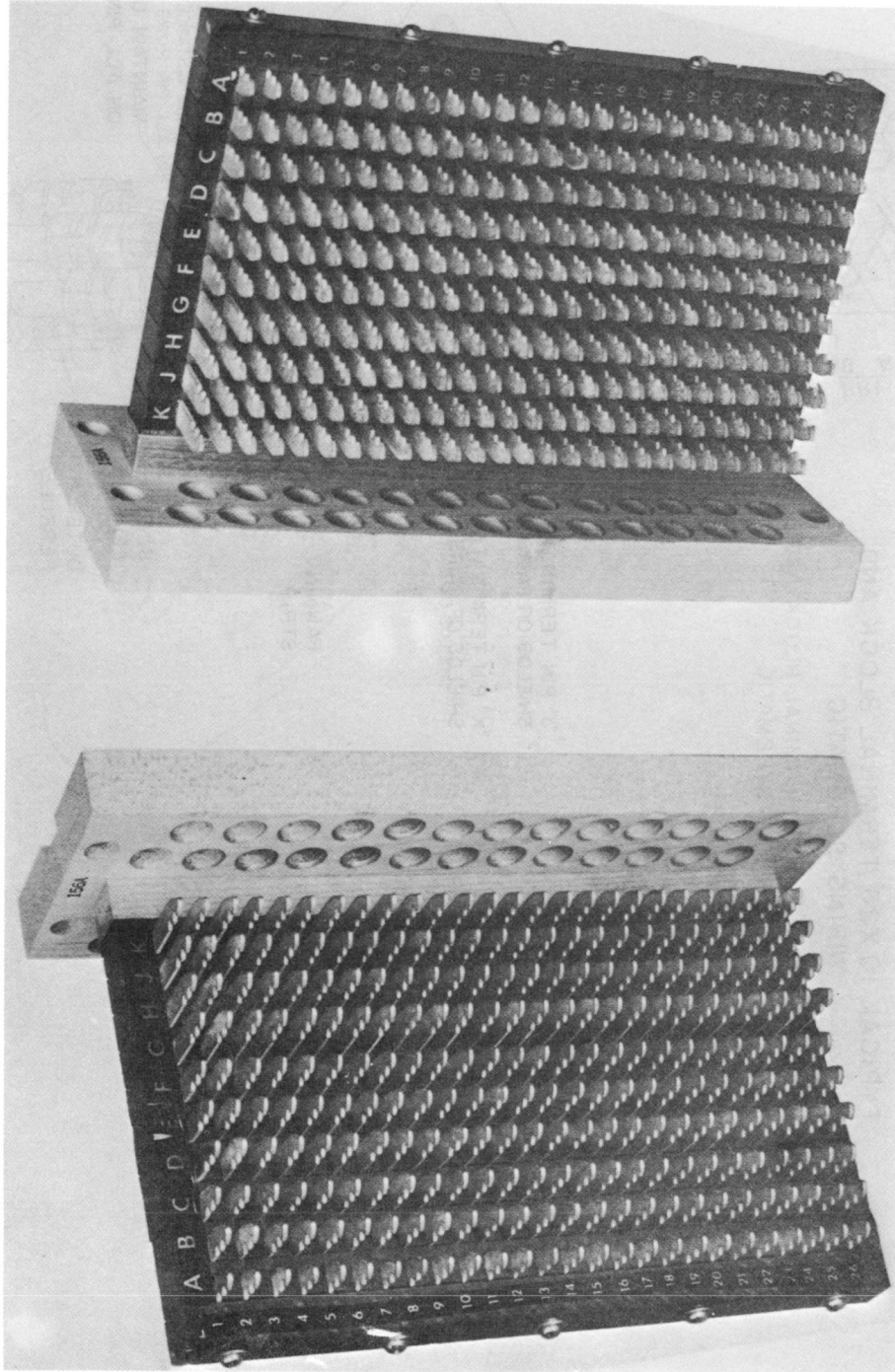

Figure 9-6. Intermediate Distribution Frame Terminal Blocks (Sheet 1 of 4)

TYPICAL 10 X 26 TERMINAL BLOCK AND
WIRING SCHEMATIC

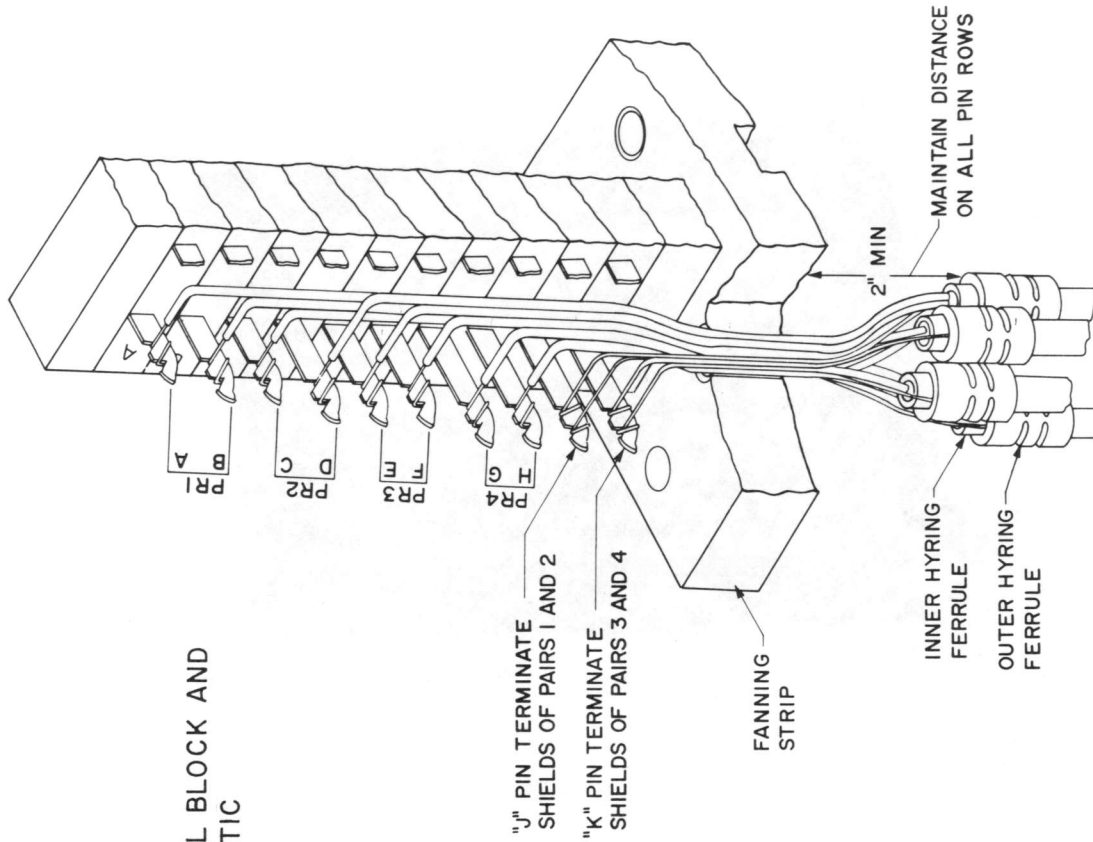
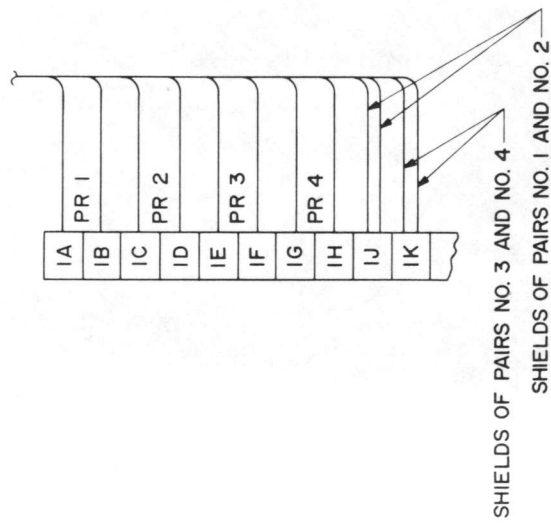

Figure 9-6. Intermediate Distribution Frame Terminal Blocks (Sheet 2 of 4)
(Showing termination of individually shielded pair cables).

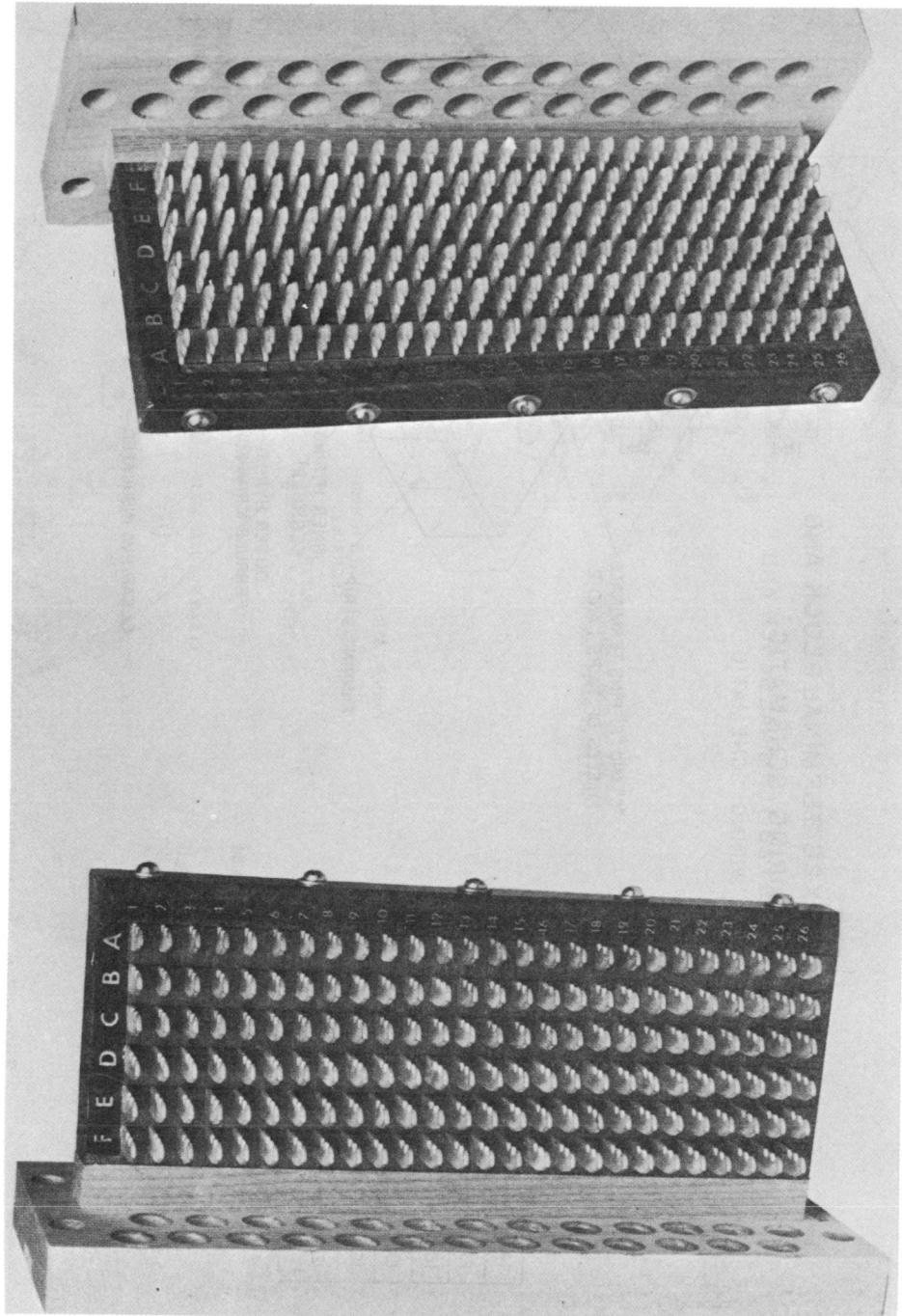

Figure 9-6. Intermediate Distribution Frame Terminal Blocks (Sheet 3 of 4)

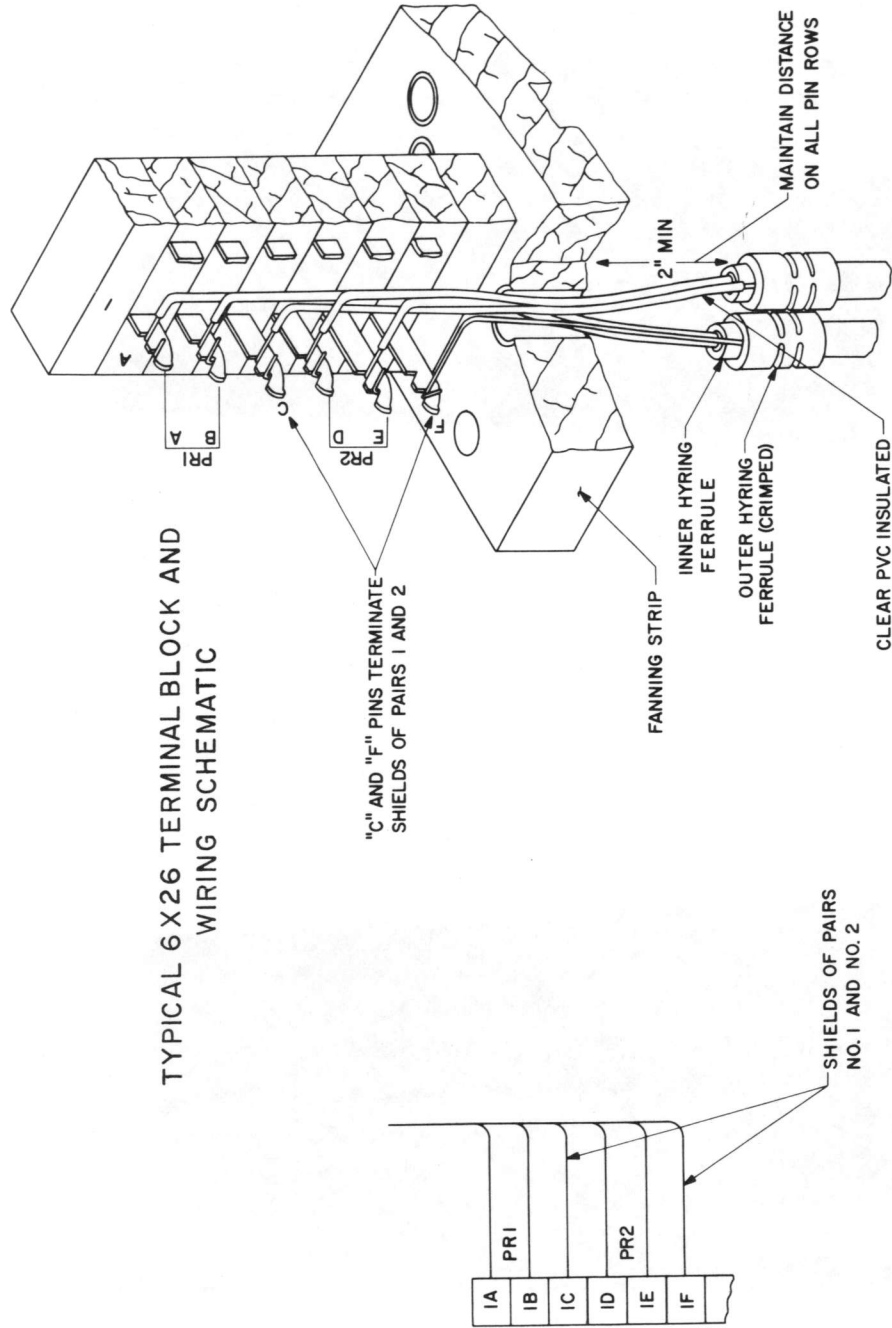
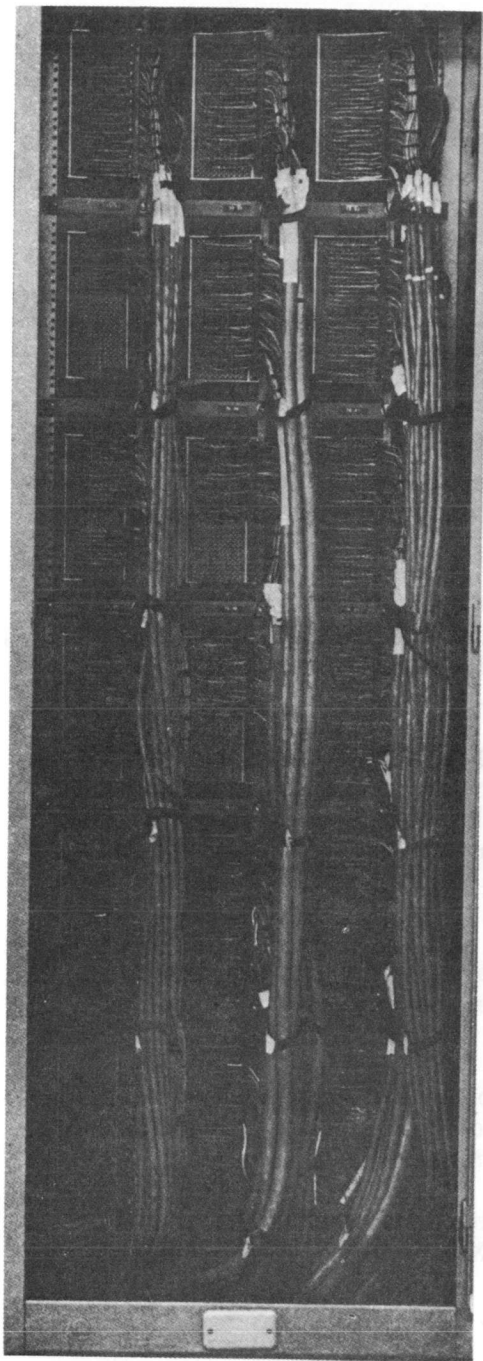
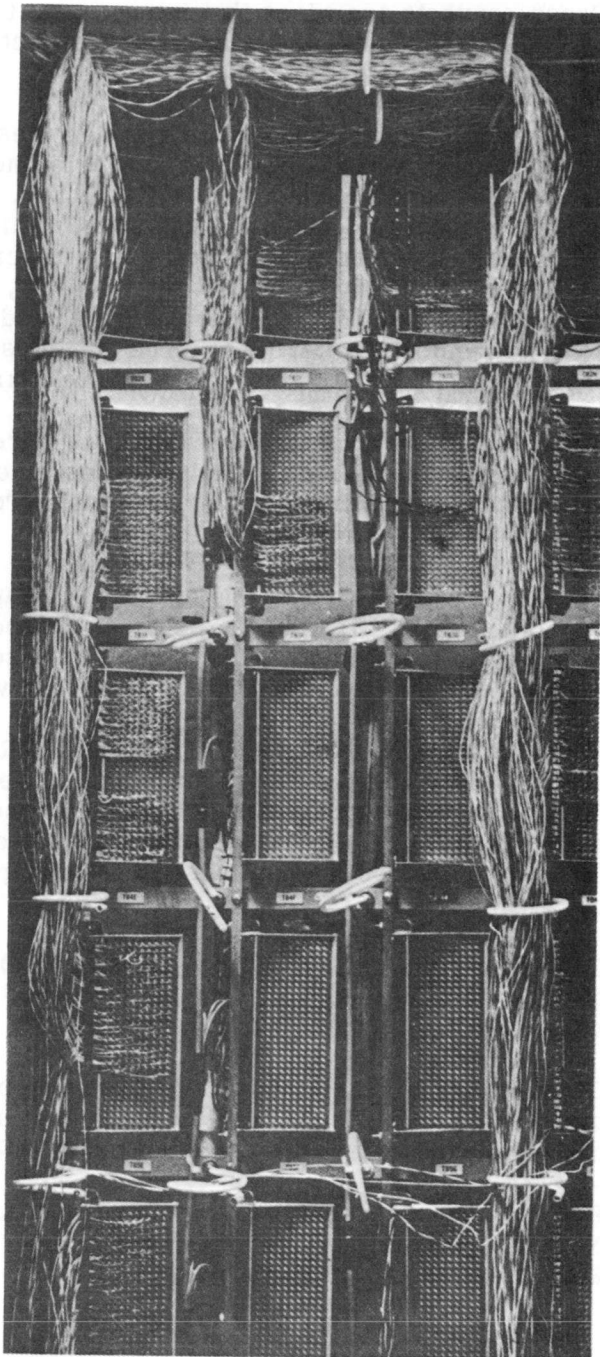

Figure 9-6. Intermediate Distribution Frame Terminal Blocks (Sheet 4 of 4)
 (Showing termination of individually shielded pair cables).



CABLE TERMINATION SIDE



CROSS-CONNECT SIDE

Figure 9-7. Typical Intermediate Distribution Frames

9.4 CROSS CONNECTS

Cross-connects are wires that interconnect terminals of the distribution frame terminal blocks. These wires may interconnect terminals on the same block or may run from one block to another.

Cross-connects are made of wire designed especially for distribution frame use. The cross-connect wires should be run in a manner that presents a neat uniform pattern such as shown in the examples of figure 9-8. Each cross-connect should be run loosely to insure adequate length and to facilitate relocation or removal as required. In general, any practice that will cause the cross-connect wire to tangle, or otherwise become caught on lugs or other objects, should be avoided. Twisted pair cross-connect wire is used. The conductors should be untwisted at each end so that each conductor enters the terminal block fanning strip individually. However, the wire should not be untwisted more than one regular twist back of the fanning strip.

Regular 22 gage black/white twisted pair wire complying with WECO Code U22P is available through general service stores under Federal Stock Number 6145-284-1499. It is also available for open purchase as an "off the shelf" item from distributors such as the Graybar Electric Company.

Cross-connection work is one of the most important operations performed at communications facilities. In the interest of good performance and minimum maintenance, each person who has occasion to run cross-connections should be familiar with the methods and practices in distribution frame wiring.

Cross-connections are made only with **DISTRIBUTING FRAME WIRE** such as described above. Jumper wire, used for connecting cable terminals, is not designed for distributing frames (IDF, MDF, CDF) and should not be used on frames. Frame wire is manufactured with insulation and wire strength to endure the pulling and bending encountered on frames. Use of other wire will increase the probability of future circuit failure.

Distributing frame wire (cross-connect wire) is available in pairs, triples, and quads to facilitate connections. The correct "pairing" should be used whenever possible.

Cross-connections connect to the right side of the protector strips and the vertical blocks, and to the top side of the horizontal blocks on MDF. When cross-connecting, the white wire goes to the terminal block RING terminal.

For details concerning the type of cross-connect wire recommended for use at Naval Security Group Activities, refer to NAVELEX 0101, 108, Naval Security Group Elements Design and Performance.

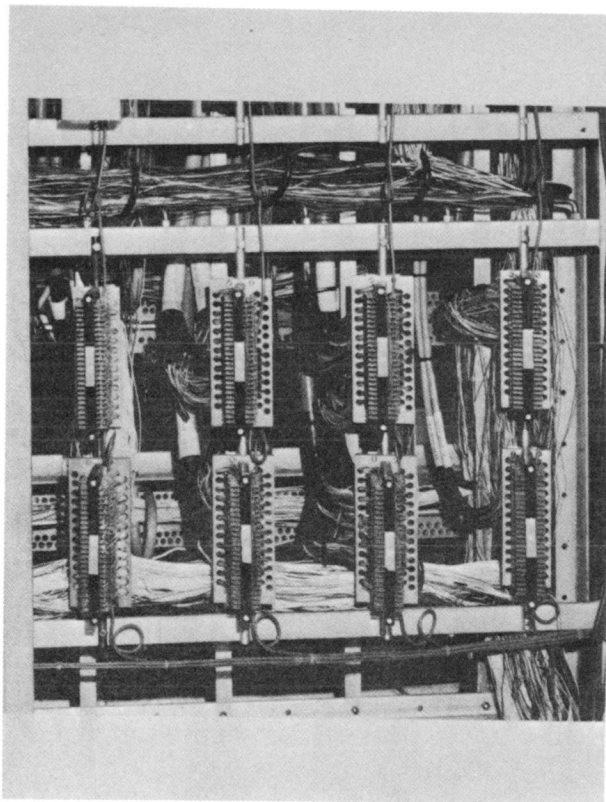

Figure 9-8. Distribution Frame Cross-Connects

