

SSB-Single Sideband Exciters

This is the sixth article of a series for personnel concerned with single sideband communications systems. It describes modulators for single sideband exciters.

The articles are from a course of instruction written by Collins Radio Company based on their own equipment.

SSB Modulators

The RF sideband is obtained by combining the audio signal obtained from the processing circuits and an RF carrier wave in an amplitude modulator.

There are many types of modulators, but they can be grouped into two main functional divisions: Those in which the modulation is dependent on the polarity of the modulating signal, and those in which the modulation is dependent on the instantaneous waveform of the modulating signal.

For practical reasons, it is more convenient to group modulator circuits in three categories, based on the circuit components:

- Rectifier modulators.
- Multielectrode vacuum tube modulators.
- Nonlinear reactance modulators.

Each group has advantages and disadvantages that control the extent of use. Because one characteristic of a modulator is frequency changing or frequency translating, this type of modulator is used in the frequency changing portion of a single sideband exciter.

Rectifier Modulators

Rectifier modulators have several advantages that make them particularly useful for single sideband generation.

Their great advantage is high stability in comparison with vacuum tube modulators. They require no heating elements. Therefore, they need no power, and no heat has to be dissipated. They can be made quite compact, have long life, and require little maintenance.

Rectifier modulators may be one of three general types: Ring, series, or shunt. These names refer to the manner in which the

diodes are connected in the circuit. In all circuits, the rectifiers are made to work like switches by the use of a large RF switching signal that greatly exceeds the audio signal level.

The rectifier modulators are almost invariably connected as balanced modulators so that, as nearly as possible, there is no output of the RF switching voltage in the modulator output terminals.

The basic circuits of the ring, shunt, and series modulators are shown in figures 1A, 2A, and 3A. It must be assumed that the rectifiers can be switched at zero voltage from an infinite back resistance to a zero forward resistance and back again.

The basic signal circuits may then be represented by the equivalents shown in figures 1B, 2B, and 3B. These equivalent signal circuits are shown for any half-cycle of the carrier voltage, with switches shown in place of the rectifiers. Practical rectifiers are not ideal, but will have a finite forward and backward resistance.

If the carrier frequency is several times that of the input signal, the resulting output waveforms are as shown in figures 1C, 2C, and 3C.

The output of these modulators consists of a series of pulses whose polarity and repetition frequency are determined by the switching or carrier voltage, and whose amplitude is controlled by the input audio signal.

A spectrum analysis of the output signals reveals the presence of an upper sideband and a lower sideband displaced about the switching or carrier frequency. A similar set of sidebands is placed about the second harmonic of the carrier frequency and some other undesired products higher in frequency.

The ring modulator has the highest efficiency. It can attain twice as much output voltage as the shunt or series modulator. When carrier balance is important, a split ring modulator may be used in which the two sets of diodes can be balanced

independently. By the use of a shunt modulator, input and output terminations of the unbalanced, one-side-grounded type can be handled.

Rectifier balanced modulators give good performance. However, if they are to continue good performance for long periods, they must be carefully made of good quality, accurately matched components. Initial carrier balance exceeding 40 decibels may be readily obtained, but it is difficult to retain this degree of carrier suppression if the environmental conditions are severe.

The level of third order intermodulation products can be held to 50 decibels below the desired sideband output signal.

Vacuum Tube Modulators

Multielectrode vacuum tube modulators, being flexible, are used in a wide variety of applications in addition to generating sidebands. They can give conversion gain rather than loss as is the case in rectifier modulators.

However, multielectrode vacuum tube modulators are quite unstable as to gain and impedance which makes them undesirable in balanced modulators. Since they contain vacuum tubes they require power, dissipate heat, and have relatively short life compared with rectifier modulators.

Vacuum tube modulators, having modulating functions dependent on instantaneous amplitude of the modulating signals, are basically one of two types—Product or square law.

Product Modulator

In a product modulator the output signal is proportional to the two input signals. In single sideband application, the input signals would be the carrier signal and the modulating signal. An example of such a product modulator is a double grid vacuum tube.

The carrier voltage is applied to one grid, and the modulating signal is applied to the other. Modulation takes place because of the combined

action of the grids on the plate current.

It is important to realize that nonlinearity is not necessary, and modulation will take place even if each grid has a linear mutual characteristic.

Figure 1. Basic ring modulator circuits.

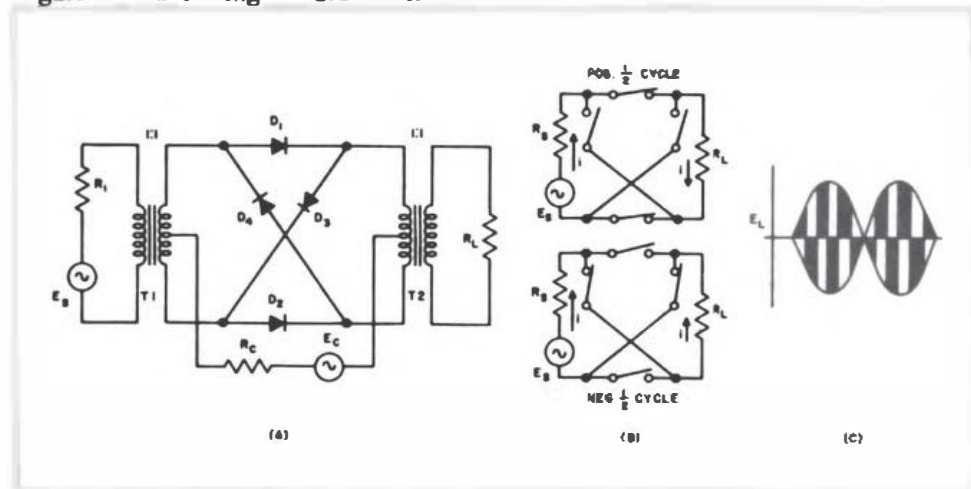

Figure 2. Basic shunt modulator circuits.

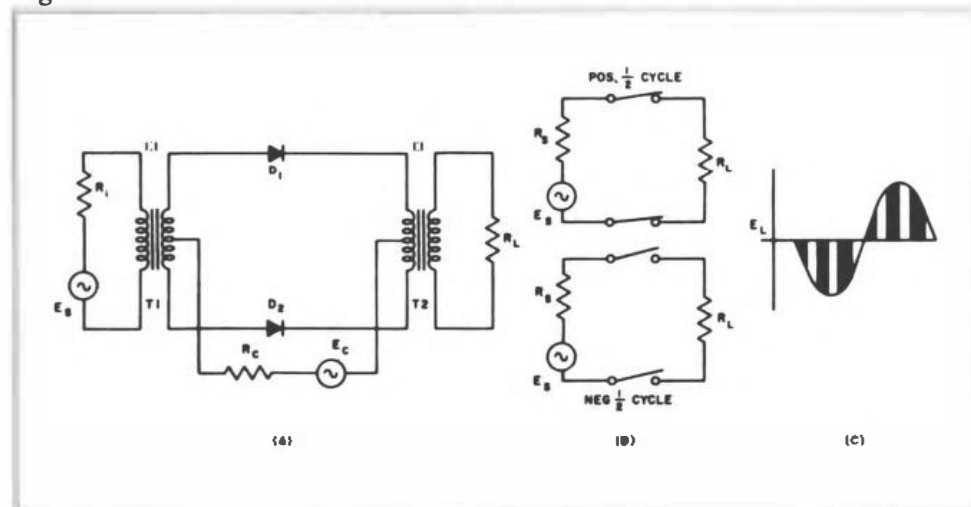
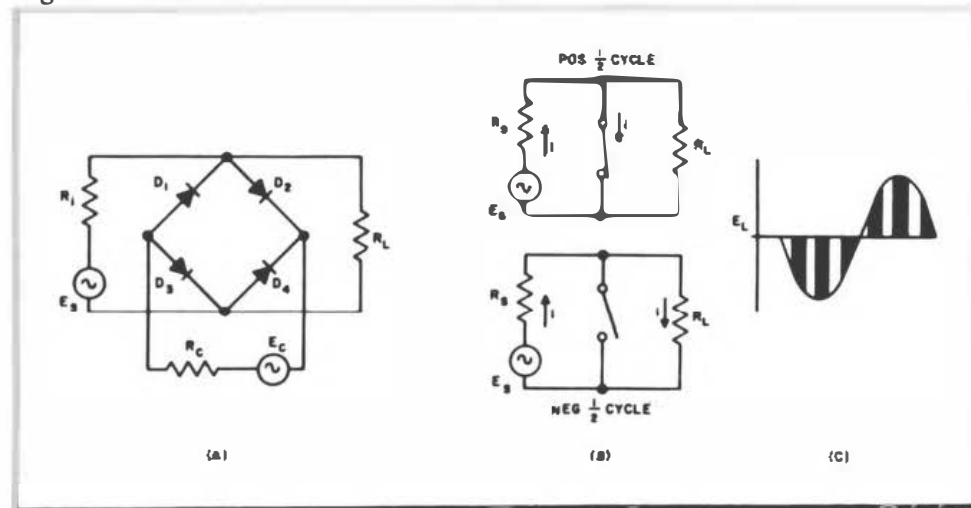

Figure 3. Basic series modulator circuits.



Square Law Modulator

In contrast to the product modulator is the square law modulator in which modulation takes place directly because of a nonlinearity.

An example of a square law modulator is a triode vacuum tube

in which the shape of the plate current versus grid voltage curve has at least second order curvature or square law. This characteristic is common to all vacuum tubes and is the cause of distortion in amplifiers.

If the curvature is purely square law, it can be shown that the output signal will contain only the desired sum or difference frequency and no other products except the second harmonics of the input signals.

Product modulators and square law modulators, because they generate a minimum of unwanted products, are particularly useful in frequency changers.

Vacuum tube modulators in which the modulating function is dependent on the polarity of the modulating signal are large signal devices that have high efficiency but also generate considerable amounts of spurious signals.

An example of such a modulator is a plate modulated triode operated class C. The modulating signal is used to vary the plate voltage applied to the class C amplifier. The resulting output is a series of pulses recurring at the carrier frequency rate and with amplitude proportional to the modulating signal. The tuned output circuit is necessary to suppress the harmonics of the signal.

The double grid vacuum tube can also be used as a switching type of modulator by increasing the amplitude of the signal applied to one of the grids. This signal can be large enough to drive the plate current of the tube to cutoff in one direction and to saturation in the other, resulting in an output signal somewhat similar in waveform to that of a rectifier modulator.

Nonlinear Reactance Modulator

Up to the present, modulators having nonlinear reactances, instead of rectifiers or vacuum tubes, have not had much use in high-frequency equipments because of the lack of materials usable at high frequencies. With suitable components such as titanate capacitors and ferrite-core inductors now available, this type of modulator is expected to be used more frequently.