

BUSHIPS

FEBRUARY 1951

ELECTRON

NavShips 900,100

CONFIDENTIAL



CONFIDENTIAL

In This Issue
A Comparison of
RADCM Intercept Antennas

A
MONTHLY
MAGAZINE
FOR
ELECTRONICS
TECHNICIANS

<i>A Comparison of RADCM Intercept Antennas</i>	1
<i>*Proper Care and Treatment of Resistors</i>	6
<i>*USN USL Notes (Centrifugal Casting of Ceramic Slips for Transducer Elements)</i>	7
<i>New Shipboard Cadillac Receiver</i>	8
<i>*Marine GCI Squadron Five Reports</i>	18
<i>*SV/-1 Modulation Networks</i>	18
<i>*SG-1B F.C. No. 63 Bulletin Error</i>	18
<i>The Field Engineer Sez</i>	19
<i>Radar Beacon AN/TPQ-7</i>	20
<i>*Antenna Group AN/SRA-3 I.B. Correction</i>	23
<i>CLC-1 Task Fleet Flagships Antenna Systems Design</i>	24
<i>*Error in NavShips 900,155</i>	29
<i>*E.S.O. Monthly Column</i>	30
<i>*False Echoes</i>	32

* These items are classified RESTRICTED.

THE PRINTING OF THIS PUBLICATION HAS BEEN APPROVED BY THE DIRECTOR OF THE BUREAU OF THE BUDGET 13 JANUARY 1950

DISTRIBUTION: BuSHIPS ELECTRON is sent to Department of Defense activities concerned with the installation, operation, maintenance, and supply of electronic equipment. If the quantity supplied is not correct, please advise the Bureau promptly.

CONTRIBUTIONS: Contributions to this magazine are always welcome. All material should be addressed to The Editor BuShips Electron, Bureau of Ships (Code 993-c), Navy Department, Washington 25, D. C. Whenever possible articles should be accompanied by appropriate sketches, diagrams, or photographs.

CLASSIFICATION: Most issues of BuSHIPS ELECTRON are classified restricted or confidential in order that information on all types of equipment may be included. Specific material published in any issue may or may not be classified, however. Each issue is assigned the highest classification of material included. Classified material should be shown only to concerned personnel as provided in U. S. Navy Regulations. Don't forget, many enlisted men are concerned with the contents of this magazine. BuSHIPS ELECTRON contains information affecting the national defense of the United States within the meaning of the Espionage Act (U.S.C. 50; 31-32) as amended.

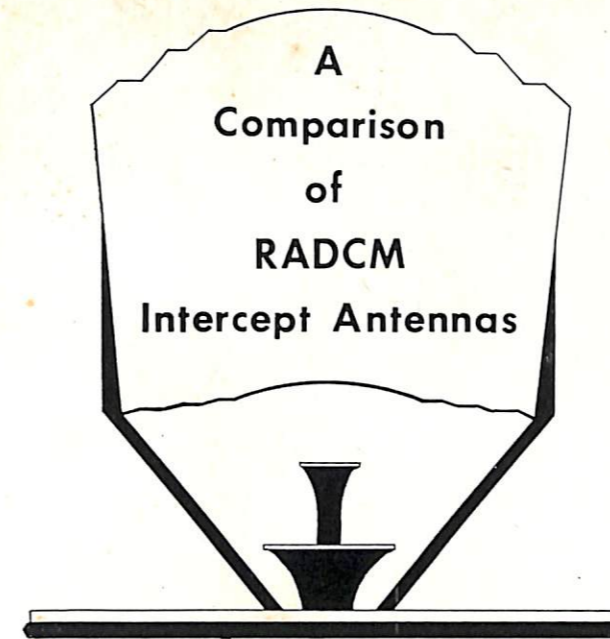

From a report by Commander Operational Development Force

During and since World War II the Navy has employed two outstanding electronic methods for air-surface detection and early warning; 1) Radar detection and 2) Interception of radiations from electronic devices carried in the approaching craft, be it surface or air. In the early months of the war, our prime method of detection was by radar, since the development and application of electronic countermeasures was not sufficiently advanced to be entirely reliable and efficient. However, detection by radar presented an undesirable aspect in that it was susceptible to intercept by the enemy forces. Still another undesirable feature was that with the power outputs and overall detection ranges available in radars during those trying months and years, initial intercept or detection of an approaching aircraft was in many cases barely sufficient to alert our forces for the impending attack. Remember, however, that the speeds at which aircraft flew in those days are now considered slow in comparison with modern jet and rocket type planes, while at the same time the initial intercept range capabilities of modern radars have not been increased on an equal ratio with the increases in plane speeds. There are many reasons for this fact, but those reasons are not considered pertinent to this discussion.

As it became more and more evident that radar initial intercepts could not afford the maximum security believed necessary, greater and greater emphasis was placed on the second method of detection—interception of radiations from electronic devices located in the approaching craft. Early in the program, we relied almost wholly on omni-directional intercept antennas in conjunction with intercept receivers and various display

devices. The major objection to this practice was the fact that no bearing determination was available when using omni-directional antennas. This pointed up the desirability of developing and producing directional intercept antennas.

In line with this trend to improve intercept equipment, the Operations Evaluation Group conducted a series of studies on the problem to determine a theoretical basis for determination of the optimum design characteristics of search receivers for use by surface ships and submarines against radar-equipped aircraft. These studies concluded that simultaneous scanning in both frequency and azimuth result in a negligible probability of intercept of radar signals. The study further concluded, however, that the continuously rotating type antenna, such as used in direction finders, affords better than calculated results. In view of these findings, it was considered desirable to obtain test data to either substantiate or disprove the postulate that a good D/F antenna can yield a higher than theoretical probability of intercept. This theory was based on the assumption that the high gain main lobe of the D/F antenna could intercept sufficient energy from the minor lobes of the radar antenna to make detection possible. If this assumption were proven true, the need for omni-directional search antennas could be eliminated insofar as frequencies covered by the D/F antenna were concerned.

The Chief of Naval Operations assigned to Commander Operational Development Force the project to "Determine comparative probabilities of intercept of radar signals by coaxial horn D/F antenna and by omni-directional antenna." The purpose of this project was to determine, under ship-board operating conditions, the comparative probabilities of intercept of radar signals by the Alford Horn Coaxial Antenna Type 1207-A as opposed to an omni-directional antenna Type AS-371/S.

To accomplish this project the following equipment was utilized by Commander Operational Development Force:

- AS-371/S Omni-directional Antenna.
- Alford Horn Coaxial Antenna Type 1207-A.
- AN/SPR-2 RADCM Intercept Receivers (2).
- LAG Signal Generator.
- General Radio Type 715A Direct Current Amplifier (2).
- Esterline-Angus Graphic Recorder (2).

The AS-371/S Omni-directional Antenna (Figure 1) is a double-cone type of antenna designed to provide wide-band characteristics. The antenna is mounted above a ground plane base at an angle of 45°, which permits reception of either horizontally or vertically polarized transmissions. In the U.S.S. MACON installation,

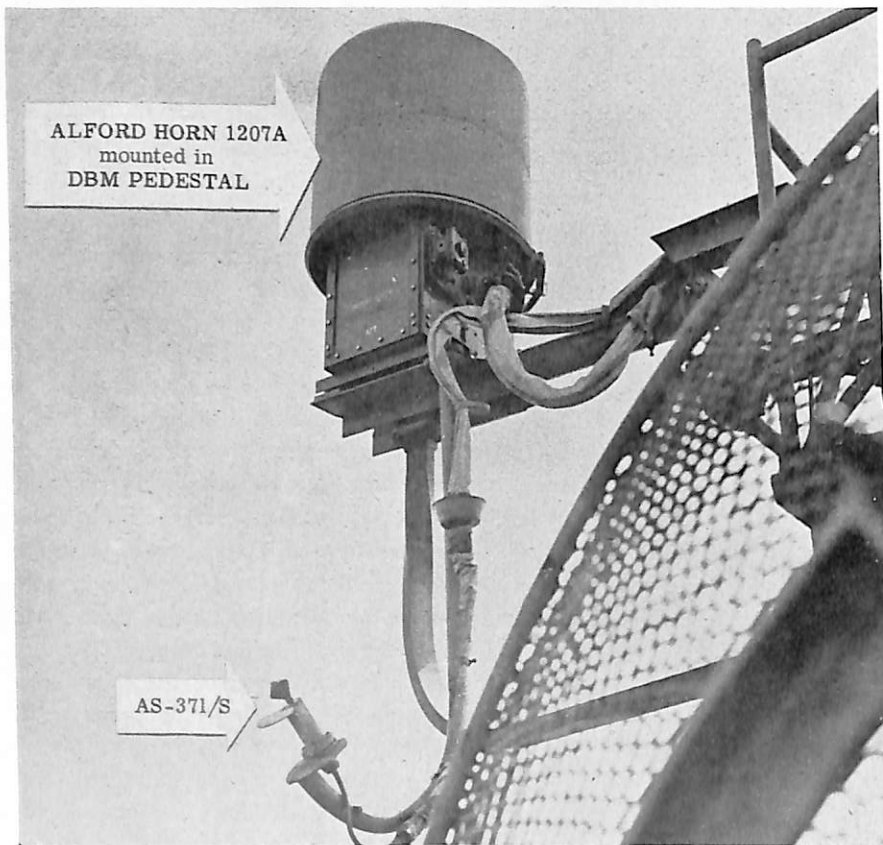

FIGURE 1—Alford Coaxial Horn Antenna (upper) and AS-371/S Omni-directional Antenna (lower) mounted on mainmast of U.S.S. Macon (ECA-132).

where all the above named equipment was installed, the antenna mount (including cone and ground plane) was tilted at a 45° angle. The ground plane is only approximately a 120° segment as illustrated in Figure 1. This antenna connects to the companion receiver, an AN/SPR-2, through a length of RG-18/U coaxial cable and appropriate fittings. RG-18/U has an attenuation of 10 db per hundred feet at 3000 Mc.

The Alford Coaxial Horn Antenna Type 1207-A is a high gain, directional antenna designed to cover a frequency range from 2200 to 10,000 Mc. This extreme range is obtained by a clever design wherein a 3-cm waveguide, covering a frequency range from 5000 to 10,000 Mc, is enclosed in a 10-cm waveguide covering a frequency range from 2200 to 5000 Mc (Figure 2). Special consideration is given in the design of this type of antenna to insure overlapping of the upper extremity and lower extremity of the 10-cm and 3-cm waveguides respectively. The ends of both waveguides are flared to produce the desired impedance characteristics. Both horns are positioned in a vertical plane. A reflector, which is cylindrical in shape, is positioned above the mouths of the horns at approximately a 45° angle. To eliminate rotating waveguide joints, with their attendant losses and mechanical problems, the reflector is made to rotate about the axis of the center of the inner waveguide. The frequency range of the horn antenna may be extended downward by making the upper surface

of the rotating reflector concave and by mounting a small fish-hook antenna from the dome above this reflector. If the correct type of fish-hook antenna is employed the frequency range may be extended to as low as 1200 Mc. The entire assembly is mounted on a modified DBM pedestal. The original DBM antenna rotation system is retained and provides a maximum rotation rate of 240-rpm for the reflector. For the Macon installation, only the 10-cm waveguide was installed. RG-48/U, having an attenuation of 1.2 db per hundred feet at 3000 Mc, was used. The exterior of the Alford Horn and its pedestal is shown in Figure 3.

The AN/SPR-2 RADCM Intercept Receiver, of which two were used in the evaluation, is a superheterodyne type receiver designed to detect signals in the frequency range of 1000 to 5000 Mc. The receiver employs two tuning heads, TN-56/SPR-2 covering a range from 1000 to 3000 Mc, and TN-57/SPR-2 covering a range from 3000 to 6000 Mc. Tuning is accomplished manually with no facilities provided for automatic frequency scanning. A pulse stretcher circuit is used in conjunction with a d-c amplifier and Wheatstone bridge to energize a front panel meter for tuning indication. The receiver input termination is 50 ohms as is the video output termination.

The LAG Signal Generator is designed to furnish an r-f signal within the range of 1200 to 4000 Mc. An unmodulated, pulse modulated, or frequency modulated

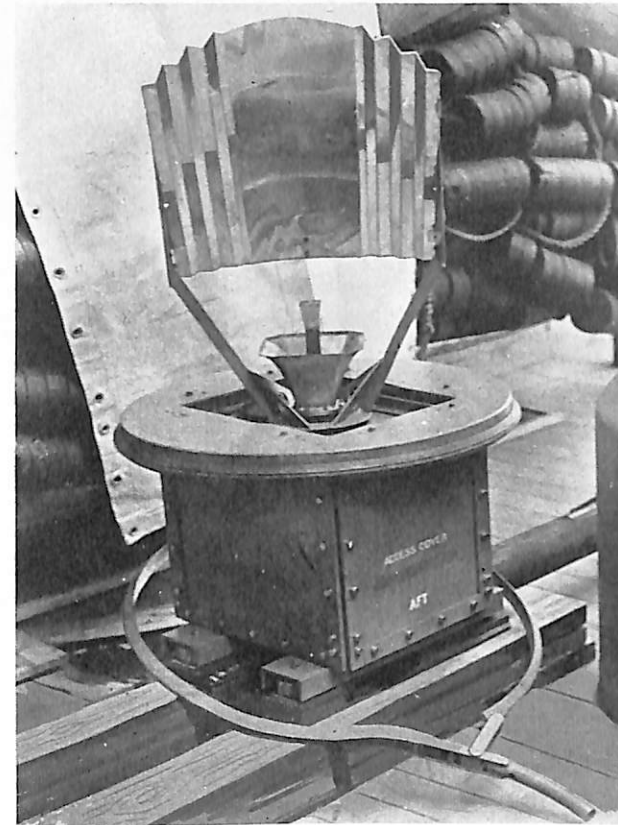
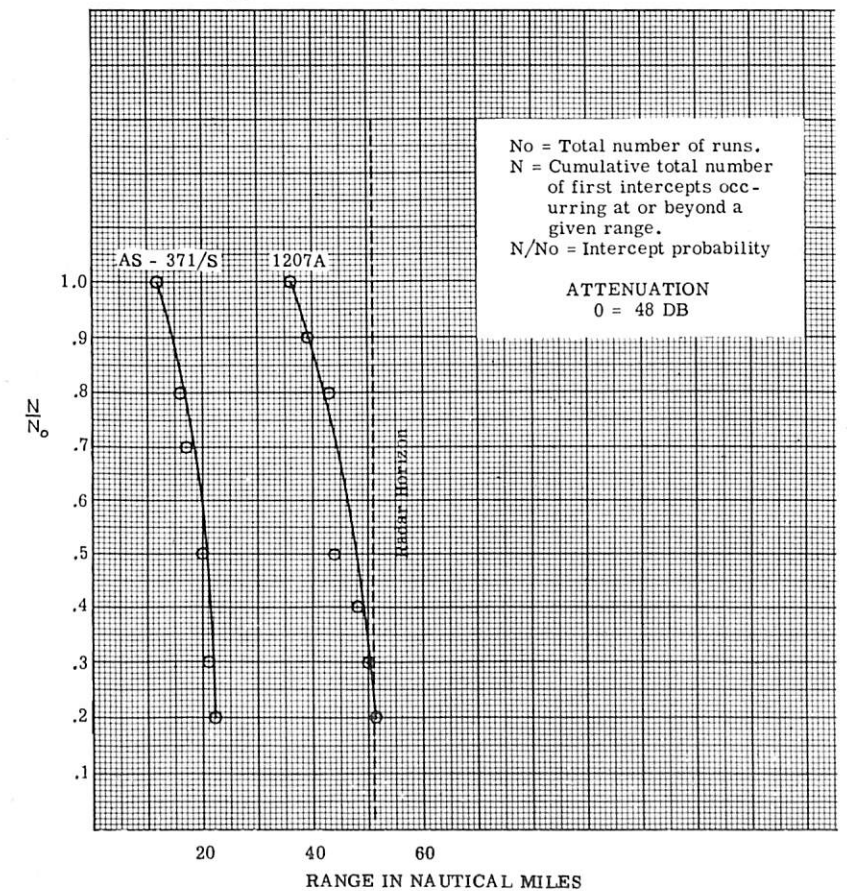

FIGURE 2—A close-up view of the Alford Coaxial Horn Antenna with protective cover removed, showing two waveguide horns immediately below the cylindrical-shaped reflector.

FIGURE 3—Intercept probability curves of the Alford Horn and the AS-371/S intercept antennas with aircraft flying at 1,000 feet, 48 db attenuation.



signal may be selected by a front panel switch. The output voltage amplitude is controlled by an attenuator which provides 100 db attenuation from a maximum output of 100,000 microvolts. A bolometer circuit, its indicating meter, and a calibration curve are provided so that the r-f output level of the unit may be checked continuously. Accurate determination of frequency is assured by the use of an absorption type wavemeter in conjunction with a crystal detector and level indicating microammeter. Facilities are provided for synchronizing pulsing of other equipments from the LAG or for synchronizing the LAG from other equipments.

The General Radio Type 715A Direct Current Amplifier is essentially a calibrated d-c millivolt-meter or microammeter used in the measurement of small d-c voltages and currents. This unit may also be used with a d-c recorder, as in this project, for the recording of any electrical quantity which may be translated into variations in small d-c currents. The amplifier is operated from a 115/230-volt, 60-cycle supply.

The Esterline-Angus Graphic Recorder provides a visual inked record upon a 6-inch wide roll chart. The chart is propelled by an electric clock motor with facilities for adjusting the speed of roll feed from 0.75" per hour to 12" per minute. The recorder movement is designed to provide full-scale deflection with 1 ma of current. It was actuated by the d-c output from the Type 715A amplifier described above.

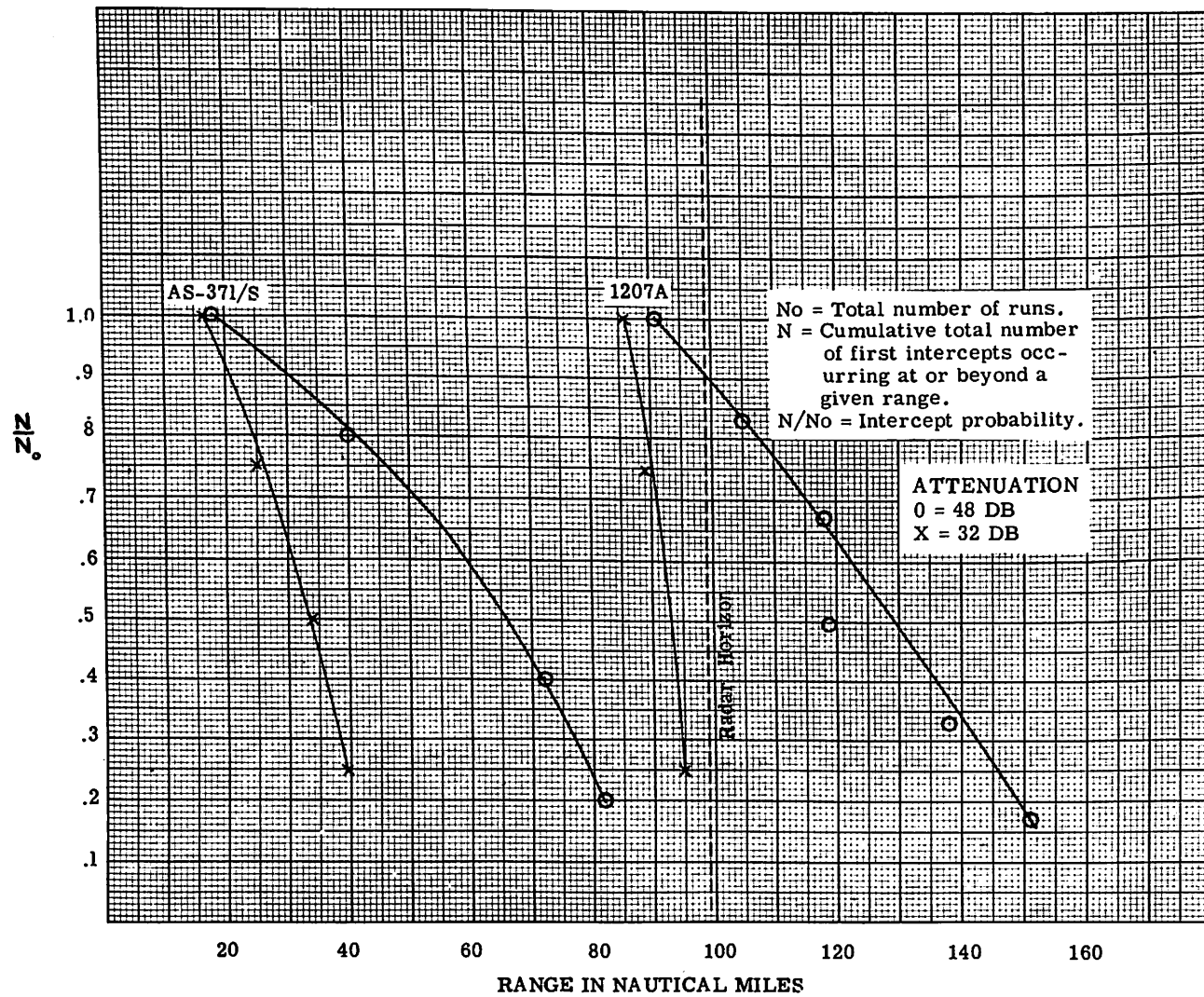

FIGURE 4—Intercept probability curves of the Alford Horn and the AS-371/S intercept antennas with aircraft flying at 5,000 feet, 48 db and 64 db attenuation.

Precautions were taken to insure that the operational tests would not be influenced by material deficiencies. To insure that results obtained were true indications of the merits of the antenna systems, it was mandatory that the supporting components, particularly the two receivers, be maintained as nearly identical as possible. Throughout the period of the evaluation the sensitivities of the receivers were maintained within 3 db of each other. It was noted that the receiver used with the AS-371/S antenna was consistently more sensitive than that used with the Alford Horn. This would work to the advantage of the AS-371/S and further points up the superiority of the Alford Horn as shown in data to be discussed later.

Intercept runs were conducted at three different altitudes, 1,000, 5,000 and 10,000 feet with a single run conducted at 20,000 feet. Since it was mandatory to maintain radar or beacon ranging contact with the target plane, and since the Alford Horn produced such great intercept ranges, it was necessary to introduce finite

amounts of attenuation in the r-f input circuits of the two receivers. This was accomplished by using identical lengths of RG-21/U coaxial cable which has an attenuation of 0.8 db per foot at 3,000 Mc. At different altitudes different lengths of this cable was used to keep the incoming signal to a level which would permit the aircraft to open beyond intercept range yet at the same time retain radar or beacon contact with the surface craft. (*USS Macon*).

After the initial intercept of the closing target aircraft, the Alford Horn System, in spite of the continuous rotation of 240 rpm, had no difficulty in maintaining a constant interception of the AN/APS-20 radar, whose antenna was also rotating at a speed of 5 rpm. In contrast to the continuous intercept by the Alford Horn was the intermittent pickup by the AS-371/S system. This antenna would intercept only the main lobe of the AN/APS-20, thereby affording only a very short signal (approximately 0.2 second) to be heard in the operators headphones. This signal occurred about 5 times per

minute at an audio frequency of 300 cps. If it were necessary to scan in frequency, interception of the AN/APS-20 or a similar radar with the AS-371/S would be highly unlikely as the operator could very easily tune through one of the 12-second intervals without any indication whatsoever. It was necessary even during this project for the Alford Horn operator to coach the AS-371/S operator on to the frequency of the intercepted signal. Two characteristics of the Alford Horn system accounted for its superior performance:

1—The Alford Horn is a high gain directional antenna and consequently will intercept weaker signals than an omni-directional antenna such as the AS-371/S. Esterline-Angus tape recordings of both systems shows that the peak amplitude of the signal provided by the horn system is greater than that provided by the AS-371/S system. It was also noted that much of the time during a closing run, the side lobes from the airborne radar antenna, as well as the main lobe, were intercepted by the Alford Horn. The AS-371/S only intercepted the main lobes and at much less range than the horn.

2—The Alford Horn system utilized RG-48/U waveguide for transfer of energy from antenna to receiver, while the AS-371/S utilized RG-18/U coaxial cable. During the project, one of the major difficulties in obtaining intercepts with the AS-371/S was the high noise level present, while in the Alford Horn Waveguide sys-

tem, there was practically no noise. Obviously this would detract from the over-all performance of the AS-371/S. To obtain a true comparison of the two antennas it would be necessary to employ waveguide on both systems, but the AS-371/S is not as yet designed to utilize waveguide. This is true for still another reason: The attenuation of RG-48/U is 1.2 db per hundred feet at 3000 Mc as compared to 10 db per hundred feet for RG-18/U at 3000 Mc. It was estimated, therefore, that the AS-271/S system had about 16 db more transmission line loss than the Alford Horn System. From the average range data table (Table I) it is pointed out that

Table I

Altitude	Input Circuit Attenuation	Average Range 1207-A	(Nautical Miles) AS-371/S
1000 Ft.	48 db	45	19
5000 Ft.	48 db	103	50
5000 Ft.	64 db	90	29
10,000 Ft.	32 db	138	57
10,000 Ft.	48 db	126	36
20,000 Ft. (one run)	0 db	275*	125

*Run not completed.

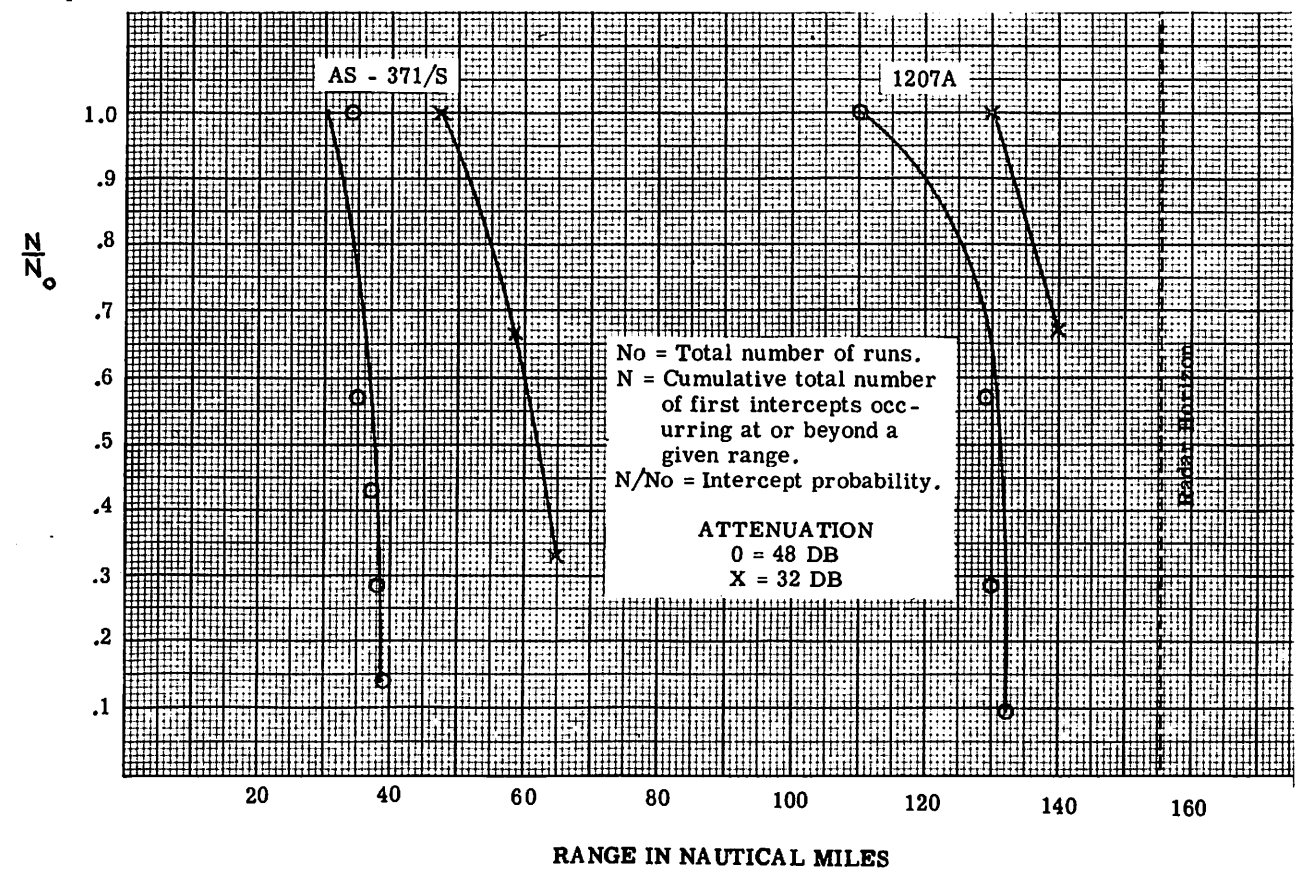

FIGURE 5—Intercept probability curves of the Alford Horn and the AS-371/S intercept antennas with aircraft flying at 10,000 feet, 48 db and 32 db attenuation.

the addition of 16 db attenuation in the AS-371/S System reduced average maximum intercept ranges 20 miles. On this basis, which is not entirely reliable, we can assume that the ranges shown on other charts could be increased by approximately 20 miles if this 16 db attenuation were not present.

From data obtained during numerous runs at various altitudes, Commander Operational Development Force developed intercept probability curves as shown in Figures 3, 4, and 5. This data in addition to other findings and developments encountered during the evaluation were highly influential in the final conclusions as outlined in the Project Report prepared by Commander Operational Development Force, upon which this discussion is based. Some of the more important conclusions contained in the report are as follows:

1—The AS-371-S Omni-directional Antenna with associated RG-18/U coaxial cable transmission line is highly susceptible to interference generated by electronic equipment throughout the spectrum.

2—The Alford Horn waveguide transmission line greatly attenuates interference which is caused by electromagnetic emissions outside its frequency range, particularly on the lower end of the range.

3—The high gain of the Alford Horn with attendant low interference level permits interception of minor lobes of airborne radar equipment. The AS-371/S intercepts only the major lobes of the airborne radar.

4—Comparative probability of intercept of the Alford Horn system is appreciably greater than that of the AS-

371/S system. Comparative probability data obtained is a measure of the relative performance of the antennas and their transmission lines, not of antennas alone. The superiority of the Alford Horn system is due partly to the antenna and partly to the transmission line.

5—The Alford Horn, in conjunction with a reasonably sensitive intercept receiver is capable of intercepting with a high probability an AN/APS-20 or lower power airborne radar out to the radar horizon. Determination of bearing within 5-10 degrees is possible.

6—Replacement of presently used omni-directional antennas and their transmission lines (3000 Mc and above) with the Alford Horn and its waveguide would greatly increase the efficiency of current shipboard RADC systems.

7—Since every advantage was given to the AS-371/S system, the results represent the minimum relative improvement to be expected with the Alford Horn system over the AS-371/S system.

The conclusions and recommendations contained in the final report prepared by Commander Operational Development Force are now being carefully analyzed by the Chief of Naval Operations and other cognizant activities. Future action as to replacement of certain antennas, transmission lines, etc., are as yet undecided. The horn type intercept antenna is not as yet an accepted instrument and this discussion is not intended to produce that impression. It is merely published for the information of interested electronics personnel to acquaint them with the activity and progress in this very important field.

circuits become quite warm during operation, and although their ratings appear to be adequate, the heat was attributed to the fact that they are mounted so that they lie flat against the phenolic strip thereby restricting ventilation. In some cases engineers have raised the resistors above the strip for better cooling. In addition to resistor failures due to heating during soldering, and to bending the pigtails, as well as heating due to current flowing through them, there is danger that vibration might either break the pigtails or put a mechanical strain on the resistors. It has become an established military specification that all pigtail type resistors must be mounted in such a way that they lie flat against the phenolic plate to protect them from harmful vibration.

It is recognized that there would be somewhat better cooling if more air space was allowed, but we can't operate them in that way. It is found that some resistors are overheating it may be necessary to increase the wattage rating.—*W. E. Newsletter*

BUSHIPS ELECTRON will devote an entire future issue to the FLEET!! The entire issue will be written by and for the FLEET. So sharpen your pencils and collect your thoughts, boys. Details will follow next month.

USN USL notes

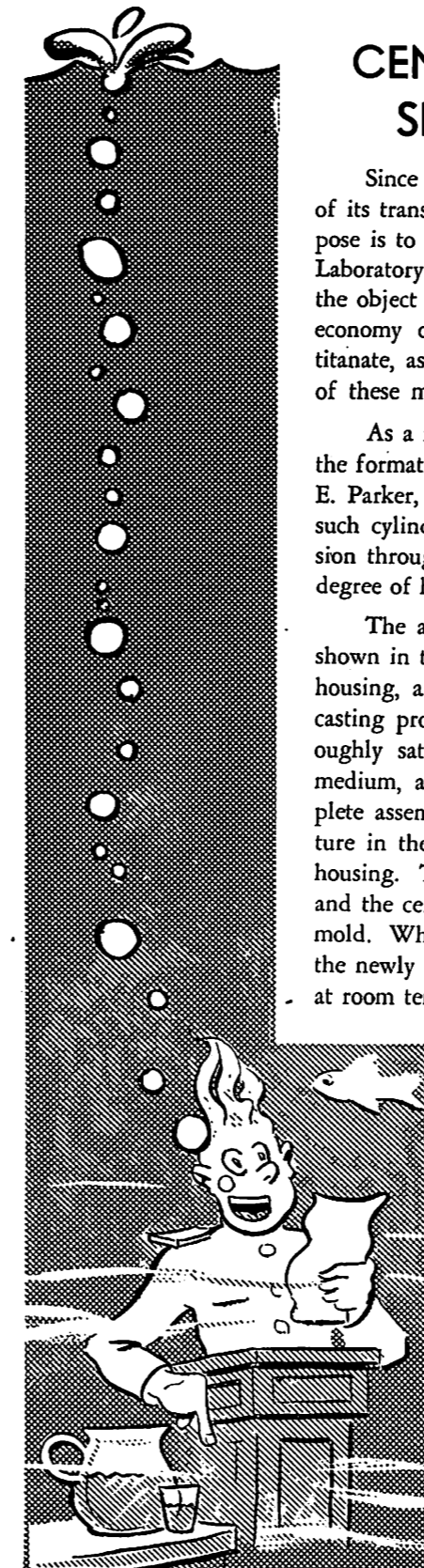

CENTRIFUGAL CASTING OF CERAMIC SLIPS FOR TRANSDUCER ELEMENTS

Since the effectiveness of any sonar component is directly related to the effectiveness of its transducer, the Underwater Sound Laboratory is engaged in a program whose purpose is to develop new and improved transducers. In connection with this program, the Laboratory is investigating new types of materials and new fabrication techniques with the object of improving transducer operating characteristics and achieving simplicity and economy of manufacture. Recent experiments with certain ceramics, such as barium titanate, as the active materials in electroacoustic transducers have indicated that the use of these materials may lead to economical production of transducer elements.

As a result of the current interest in ceramics, a novel method and an apparatus for the formation of ceramic cylinders of homogeneous structure have been devised by David E. Parker, Harold A. Cramer, and Hector J. Cini of the Laboratory staff. In the past, such cylinders have been formed by means of conventional molding techniques, extrusion through nozzles, or pressing; these methods, however, did not assure a satisfactory degree of homogeneity in the castings.

The apparatus required for the new centrifugal method of casting ceramic slips is shown in the accompanying illustration. Considered briefly, it consists of a porous mold housing, a porous mold and stoppers, a housing cap, and a means of rotation. In the casting process, the ceramic slip is poured into the plastic mold, which has been thoroughly saturated with water in order to prevent rapid absorption of the suspension medium, and the apparatus is assembled as shown in the illustration. When the complete assembly is rotated at high speed, the resulting centrifugal force causes the moisture in the mold to be discharged through the vents which may be noted in the mold housing. The suspension medium is discharged through the mold and mold housing, and the ceramic material is deposited uniformly upon the interior wall of the cylindrical mold. When this step in the casting process has been completed, the plaster mold and the newly formed ceramic cylinder are removed from the assembly and permitted to dry at room temperature. The ceramic cylinder shrinks while drying and may be easily separated from the mold. When dry, the cylinder is ready for final processing, i.e., firing and grinding or cutting.

It is felt that this method of molding offers distinct advantages over other methods in that both structural homogeneity and uniformity among successive products are provided.

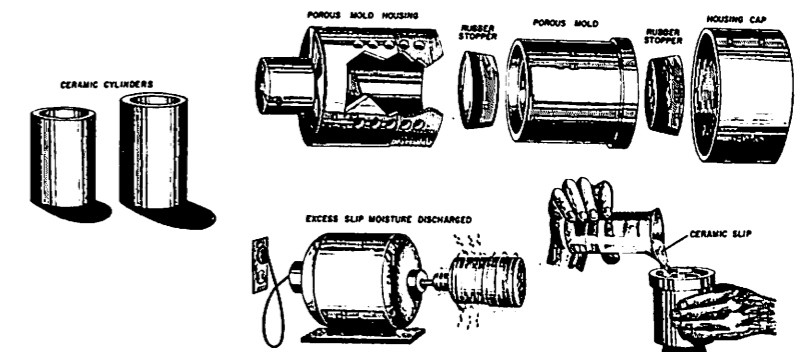

proper care and treatment of resistors

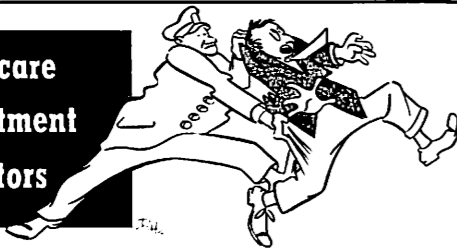

In the past we have had trouble with resistors that have changed value after being in service for a short period of time. After a lengthy conference with the manufacturers of these resistors it was definitely established that either mechanical strain or heat can cause this change. Certain precautions should be observed. The pigtails between the end of the resistor and the point of soldering should never be less than 1/4" in length for resistors of half watt size or smaller. Likewise, there should never be a sharp bend in this pigtail unless precautions are taken to prevent a strain within the resistor body. If the pigtail must be bent, the pigtail should be gripped with pliers between the point of bend and the body of the resistor. The pigtail also should be gripped with some heat absorbing medium such as pliers or the suggested copper jaws during soldering operations.

It has been reported that composition resistors in some

new shipboard *Cadillac* receiver



by

HAZELTINE ELECTRONICS CORPORATION

Hazeltine Electronics Corporation is presently completing the design and production of a new and improved shipboard receiver to be used with AEW equipment. This receiver includes new and highly versatile indicators together with other components having advanced and improved features. The equipment is designated Radio Receiving Set AN/SRR-4 and it is expected that it will be in service in fleet units in a few months.

The complete Radio Receiving Set AN/SRR-4 consists of the following components.

Nomenclature	Function of Equipment	Number used in typical installation
AS-466/SR	Antenna	2
SA-215/U	Rotary Switch	1
R-360/SRR-4	Radio Receiver	2
KY-59/SRR-4	Video Decoder	1
CV-121/SRR-4	Data Converter	1
SG-31/U	Signal Generator	1
IP-98/SPA-9	Tracking Indicator	1
IP-97/SPA-8	Repeater Indicator	1
PP-560/SR	Power Supply	2
TF-129/SP	Power Transformer	2

The first six items of the above table are components of the receiving system. The last four items represent the display system. The receiving system features automatic frequency control and circuits for minimizing rotational error and malfunctioning due to noise. The mechanical design is such as to permit ease of maintenance.

The display system includes indicators in two forms, which with their power supplies have been designated Repeater Indicator AN/SPA-8 and Tracking Indicator AN/SPA-9. These have been designed for general use individually with a wide variety of radars, as well as for use as a pair in AEW and similar applications where an operator at one unit, tracking a friendly craft, causes the motion of that craft to be cancelled out on the other indicator. Special attention has been paid to the problems introduced by high-speed aircraft.

Range and bearing on these indicators may be read directly from counters rather than from dials, affording easier reading and greater accuracy.

The range is continuously adjustable from 4 to 250 miles. This feature permits adjusting the display to agree with map overlays and avoids losing high-speed aircraft, as may occur in conventional indicators with fixed ranges when switching from range to range. It is possible, by off-centering and adjusting the range, to magnify any portion of the display without geographic distortion. Also, the range and bearing of targets on the magnified display may be determined even though the location of the ship may have been removed from the display in the process of magnification. This last is accomplished by range and bearing markers introduced electronically. They are time-shared with the display and so are continuously visible rather than appearing once every revolution of the antenna or only when a switch is thrown.

In one of these indicators, the AN/SPA-9, the origin of the electronic range and bearing markers is not fixed at the ship location but may be moved about so as to permit determining the range and bearing from any one target to any other target for fighter-direction applications. The information is made available on synchro generators for transmission to computers or plotting centers. Also, in the case of the repeater indicator, syn-

chro data from shipboard dead-reckoning analyzers can be received. This information can be mixed with manual and AEW tracking off-centering to cancel out the motion of the ship as well as that of the AEW aircraft, creating a fixed land-mass display with the ship moving relative to it.

The tracking and repeater indicators are basically the same, the differences being primarily limited to the features required to supply and utilize AEW tracking information.

These various advantages account for the adaptability of these indicators to both AEW and general uses.

The physical features of the two indicators are virtually the same, with the general appearance shown in Figure 1. As an alternative to use in the vertical position, the equipment can be installed with a forward tilt.

Maintenance is simplified through the use of a crank-operated mechanism which tilts the indicator forward on its base. This is shown in Figure 2 where it can also be seen that the individual chassis are mounted so that they can be swung outward to make the parts more accessible.

Features of the AN/SRR-4 Indicators

In addition to the usual mechanical cursor, these indicators include an electronic cursor and strobe. These share time with the radar information, one out of nine radar sweeps being replaced by a cursor sweep. The operational advantage of this electronic cursor is not confined to the elimination of parallax, as will be seen shortly. Because of the electronic switching, the cursor appears simultaneously with the video and so may be used with a fully bright picture at all times, rather than with the fading picture that occurs with manual switching. An electronic range strobe appears on the cursor. Because it also appears all the time, it may be moved at will from target to target, obtaining range

accurately and quickly without waiting for the radar sweep to come around to the sector being used.

An important advantage of the electronic cursor and strobe arises in the use of off-centering and magnification. When an off-centered display is used, the electronic cursor and range strobe give correct readings to a target even though the origin for the cursor and strobe may be off the face of the tube, and these readings are read directly from counters without any calculation or interpolation.

As previous standard practice, radar indicators have been designed with a number of fixed sweep ranges, and the operator has selected from these the best for his immediate need. An indicator of this sort when used with a variety of radars having different repetition rates and sweep ranges will often encounter unfavorable combinations of repetition rates and sweep ranges. Either sweep count-down occurs (with resulting failure to utilize the full radar information and also the reappearance of nearby targets at long range), or some of the useful range of the radar does not appear on the PPI. A continuously variable sweep-speed control is incorporated into the AN/SPA-8 and the AN/SPA-9 indicator equipments; this makes it possible to select the most useful sweep range for any particular conditions, without count-down, reappearance of echoes, or loss of radar range.

The above advantage, though important in many cases, may actually be considered minor compared to two other advantages of continuous sweep-speed control. The first of these is apparent in the tracking of small high-speed aircraft, where the use of continuous sweep-speed control will reduce the probability of losing the target when sweep speed must be changed. The sweep range can be changed gradually, so that the target can be followed easily.

Another advantage of continuous speed control is evident when a succession of different map overlays are desired on the PPI. The continuous sweep speed control permits the quick fitting of the display scale to the map scale by the turn of a knob, a process much easier than fitting the map to the display. The photographic processes of enlargement or reduction and developing are avoided.

The sweep-speed control covers the range of 4 to 250 miles, with a logarithmic taper, and with no switching by the operator.

The indicators are equipped with manual off-centering controls which permit the bodily displacement of the picture so that any target within range may be brought to the center of the display. The sweep-speed control may then be turned to expand the picture, giving magnification up to approximately six times in linear dimensions. Thus a target at a range of 60 miles may be seen on a display of ten miles radius, permitting an examina-



FIGURE 1—Repeater Indicator IP-97/SPA-8, a unit of Radio Receiving Set AN/SRR-4.

tion in which the detail is limited only by the radar, rather than by the PPI. In this way, for example, a target may be scrutinized to see if it consists of one or several vessels.

At this point some differences between the AN/SPA-8 and AN/SPA-9 indicator equipments may be noted. Both are provided with manual off-centering, continuous sweep-speed control, and the electronic cursor and range strobe. The tracking indicator equipment AN/SPA-9 has in addition an electronic tracking strobe. In AEW relay radar applications the operator of the tracking indicator will make the tracking strobe follow his own ship's position, on a plane-centered display. The tracking information so derived is transmitted by synchros to the repeater indicator equipment (AN/SPA-8) where it is utilized to off-center the display, cancelling the motion of the radar-bearing plane and placing the ship at the center of the picture.

The repeater indicator has an additional synchro channel for producing off-centering. This channel uti-

lizes information about the motion of the ship taken from the dead-reckoning analyzer (DRA), cancelling this motion so that land masses are stationary in the display. A map overlay on the face of the indicator may therefore be stationary; it will remain aligned with land masses in the display, with only infrequent adjustment. The operator sees his ship moving in the display.

The range of sweep speeds provided is 4 to 250 miles per radius, and the range of repetition rates is 60 to 2000 sweeps per second. If no provision were made to maintain the sweep brightness constant, switching from one radar to another and changing the sweep speed could result in large changes of brightness, and would require the operator's attention in adjusting the brightness. An automatic compensating circuit keeps the background brightness substantially constant without any attention from the operator.

The operation of the indicators will be described in some typical applications in order to illustrate the use and benefits of the special design features. No attempt is made to cover all the possible applications.

Use in AEW service is shown in Figures 3 and 4, where the displays on the tracking and repeater indicators respectively are given. The operator of the tracking indicator has made use of off-centering in order to bring his own ship into the center of the display, and has employed a fast sweep, thus obtaining an enlarged image. This enables him to hold the tracking strobe over his own ship more easily. This operation establishes the reference origin of the electronic cursor and strobe of the repeater indicator. Figure 4 shows the resulting picture on the repeater indicator, and it will be noted that the electronic cursor starts at the own-ship echo. The operator of this indicator has rotated this cursor so as to pass through the target (the mechanical and electronic cursors are rotated by the same control knob). The operator has also placed the range strobe on the target. The bearing information thus obtained with the electronic cursor can be transmitted to remote plotting centers or gun-laying computers by means of a synchro system, employing a 6G synchro; it can also be read directly and accurately from the bearing counter. Similarly, the range information can be transmitted to remote points by means of 5G and 6G synchros for tactical utilization. The bearing and range information will continue to be correct and relative to the ship, even if the operator of the repeater indicator uses manual off-centering to the extent that the ship is no longer visible on the display, so long as the operator of the tracking indicator keeps his tracking strobe on the image of the ship.

Additional operating possibilities available to the operator of the repeater indicator are to employ off-centering to bring the target nearer the center and then to introduce magnification. At any time he can remove

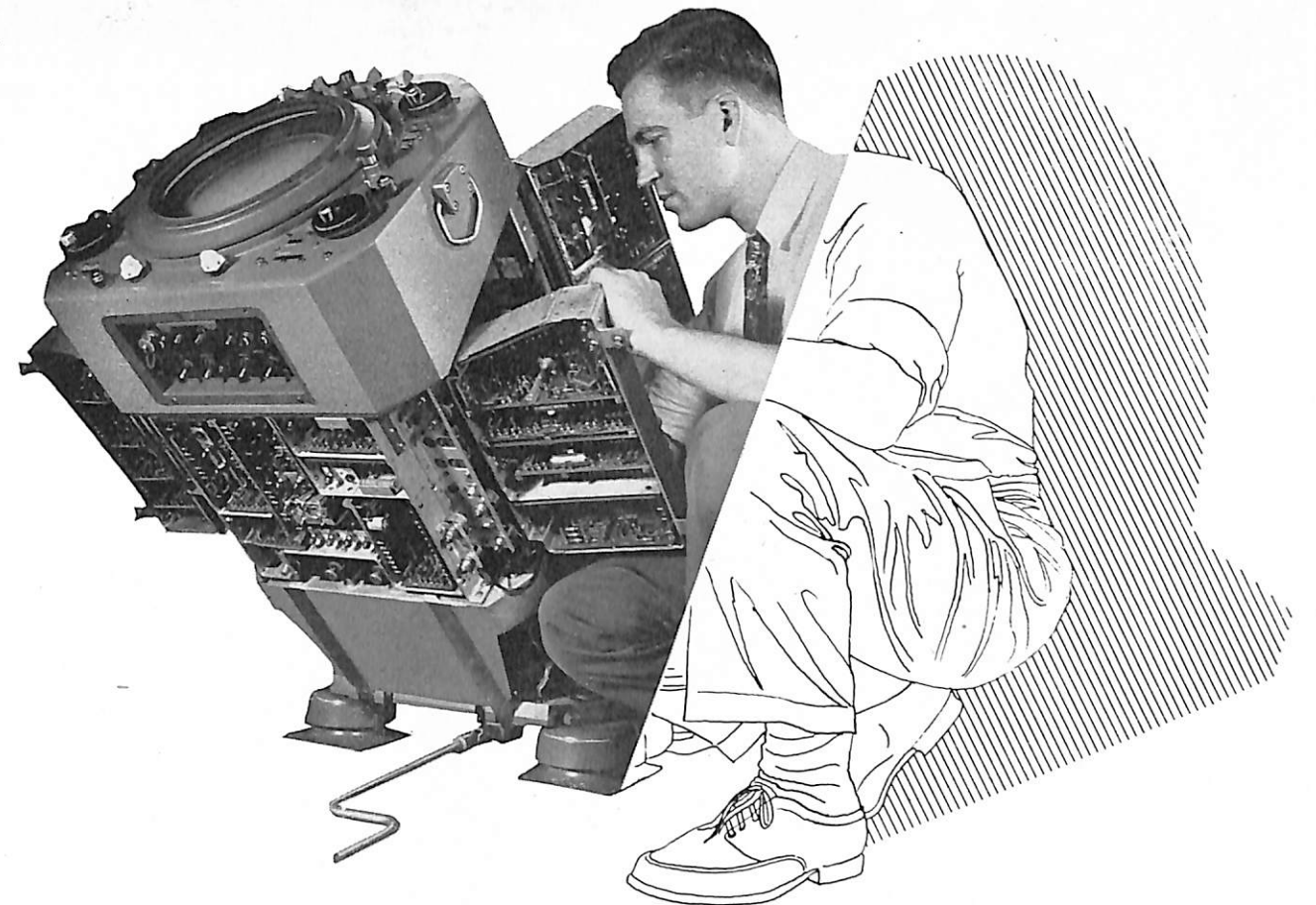

FIGURE 2—Indicator IP-97/SPA-8 with chassis opened to reveal construction.

this off-centering and return to a ship-centered display for a check of nearby conditions.

The tracking indicator is well adapted for use in fighter direction. In this application, the operator may place the CURSOR AND RANGE STROBE switch in the ON position, and the TRACKING STROBE switch also in the ON position. Adjustment of the regular tracking controls then locates the origin of the electronic cursor at any point of his choice and affords range and bearing readings with respect to this point. In Figure 5, the operator has taken this origin at the friendly plane, which is identified by IFF, and has adjusted the range strobe and also the angle of the electronic cursor onto the bogey plane. The locations of both planes may be transmitted by standard synchro channels to remote stations where the information is required. (The images of the AEW plane and the operator's own ship in Figure 5 are for a case where a tracking indicator in AEW service is temporarily assigned to fighter direction. The tracking indicator is similarly usable for fighter direction with a local radar.)

Features of the Radio Receiving Set AN/SRR-4

In addition to the indicators, a complete installation of the AN/SRR-4 consists of two antennas, an antenna

switch, and the cabinets shown in Figure 6. These are shown stacked about as they would be in a rack installation. The power supply is shown in Figure 7.

The receiving system incorporates several important advances over the techniques previously employed. The receiver proper R-360/SRR-4 includes automatic frequency control. The video decoder utilizes a system of narrow gates to reduce the probability of system failure due to interfering pulse signals or noise and has provision for recovering synchronism of the tracking gates should temporarily lose the synchronizing pulses. The data converter contains circuits to reduce the overall time lag of the system to zero as compared with lags of the order of two degrees of azimuth formerly present. In the old video decoder the sine and cosine voltages were modulated upon a 60-cycle carrier with an attendant dependence upon tube characteristics. In distinction, the new data converter employs diode switching bridges, which considerably reduce errors from tube changes.

The two main aims in the mechanical design have been light weight and serviceability. In the interest of the former, all cabinets and panel and chassis units are made of aluminum, and light-weight alloys are used where feasible for castings and massive parts. The units (receivers, signal generator, video decoder, and data

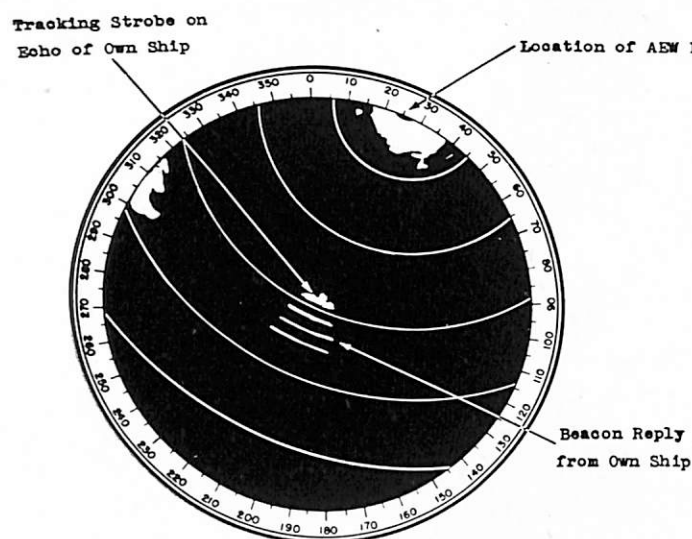

FIGURE 3—A typical Tracking Indicator Display (AN/SPA-9).

converter) which will be mounted in a suitable framework are all drawer-type chassis, and may be withdrawn on rollers approximately two-thirds their length for inspection and servicing. As far as possible, vertical-pan chassis are arranged with their parts exposed at the side when the unit is in the withdrawn position. Parts located below the main horizontal chassis may be inspected and replacements of large parts may be made by complete withdrawal and inversion of the unit. This may be accomplished without disconnecting any cables. All cabinets, including the indicators, are dimensioned so that they can pass through the hatch of a submarine.

Since on many surface ships it will be impossible to obtain a single antenna location good enough to cover the entire horizon satisfactorily, two antennas are provided. One of these is to be mounted on each side of the main upright structure of the ship, so that each will cover approximately 180° of the horizon. Each antenna is connected to one of the receivers through the manually operable coaxial switch SA-215/U; this switch provides the possibility of interchanging antennas between receivers, so that, after partial equipment damage or failure, a remaining good antenna and receiver can always be used together.

The provision of two antennas and receivers gives the means for "diversity" operation, with its well-known advantages for obtaining good reception under difficult conditions. In brief, if one antenna is not getting the signal, the other antenna probably is and can fill the need. Two receivers are provided, one for each antenna, because in this way the outputs of the two receiving channels can be combined in such a way as to avoid an increase of noise or interference which would otherwise occur.

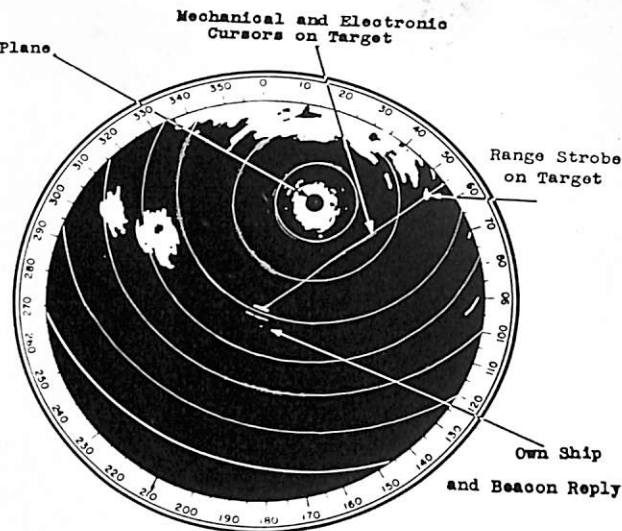

FIGURE 4—Repeater Indicator Display AN/SPA-8, part of the Radio Receiving Equipment AN/SRR-4.

For submarines a single omni-directional antenna is being procured. In this case no antenna switch SA-215/U is required. Only one radio receiver R-360/SRR-4 is employed, with its switch on an additional position which is marked "Normal" to indicate that the diversity feature is not being used.

The relayed signal received from the search plane consists of three or four groups of sync pulses, followed by video conveying the radar or IFF information. Each of these groups of sync pulses consists of three individual pulses. The timing of the groups conveys the sync data, a method known as pulse-time modulation.

The receiver decodes the triple-pulse groups, comprising the synchronizing signal, into single pulses, and passes them on to the video decoder, as shown in Figure 8. The radar and the IFF video output, constituting the essential intelligence received, is delivered over other

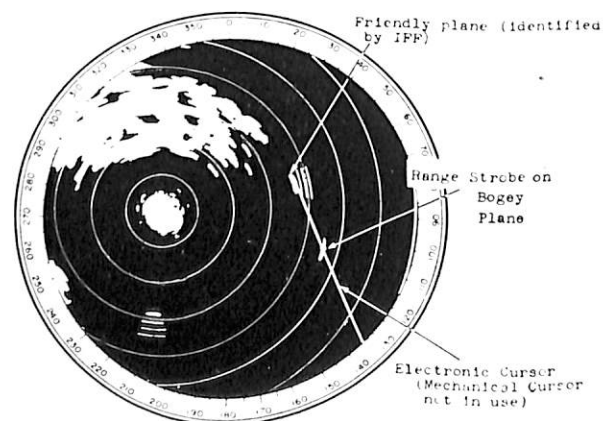

FIGURE 5—Operational use of tracking indicator in fighter direction work.

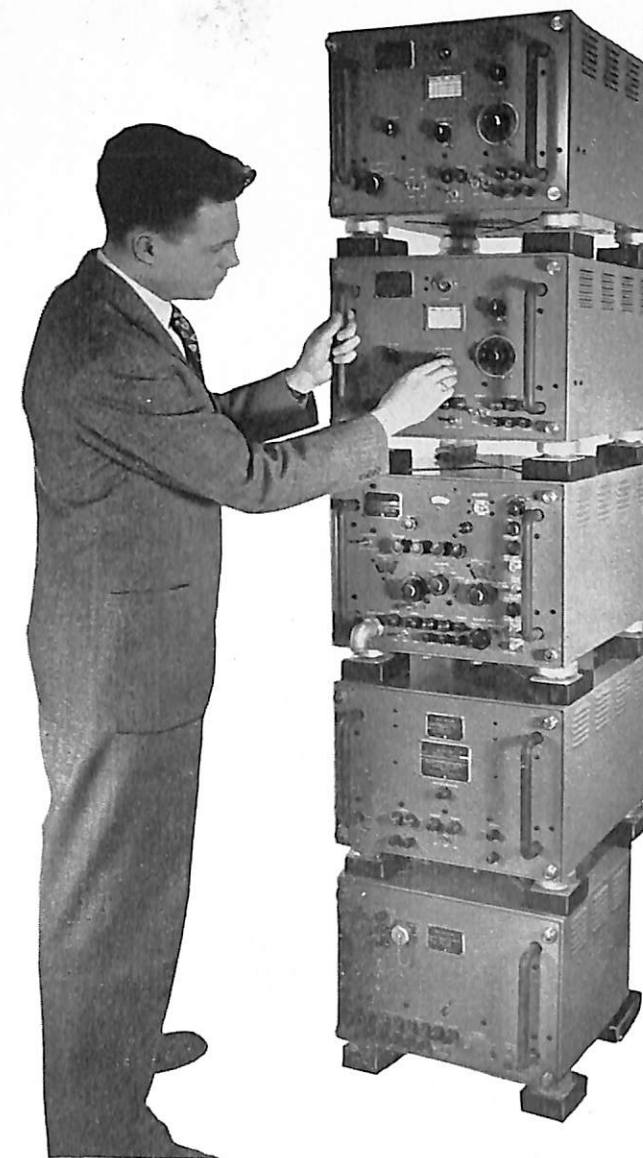

FIGURE 6—Components of Radio Receiving Set AN/SRR-4 for rack mounting. From top to bottom are shown two receivers, signal generator, video decoder, and data converter. Not shown are antennas, antenna switch, the indicators and their power supplies.

connections directly to the tracking and repeater indicators.

The video decoder is supplied by the receiver with the three or four single-pulse sync signals. The first, or "basic" pulse of each transmission serves to indicate the start of the repetition cycle and establish a basis of time reference. It is followed by the "sine pulse" after a time interval which is a measure of the sine of the azimuth angle of the radar beam. The "cosine pulse," in turn, follows the sine pulse after a time interval indicating the cosine of the azimuth of the beam. Since the sine and the cosine together (each with plus or

minus values) uniquely establish the angle at any value from zero to 360 degrees, this information, translated into proper form, will synchronize the PPI rotation with the radar beam. A fourth pulse follows the cosine pulse by a constant time interval and is synchronous with the "main bang" of the transmitter of the airborne search radar. This fourth pulse is therefore known as the "transmitter pulse" and is used, after processing through the decoder, to trigger the PPI sweeps on both indicators. The function of the video decoder is to translate the basic, sine, and cosine pulses furnished it by the receiver into dc voltages slowing varying in accordance with the sine and cosine of the azimuth of the radar beam. The decoder also furnishes enabling pulses for the ship's S-band beacon which identifies the particular vessel on the display.

The sine and cosine d-c voltages generated by the decoder are supplied to the data converter, where they are changed into standard synchro data. The latter are then ready for synchronizing the PPI sweep rotation of both indicators or other remotely located indicators with the AN/APS-20 antenna beam.

All units of the AN/SRR-4 will operate on 115-volt 60-cycle power. The signal generator, however, which is intended also for testing and servicing of the airborne AN/ARR-27, can be used with power-supply frequen-

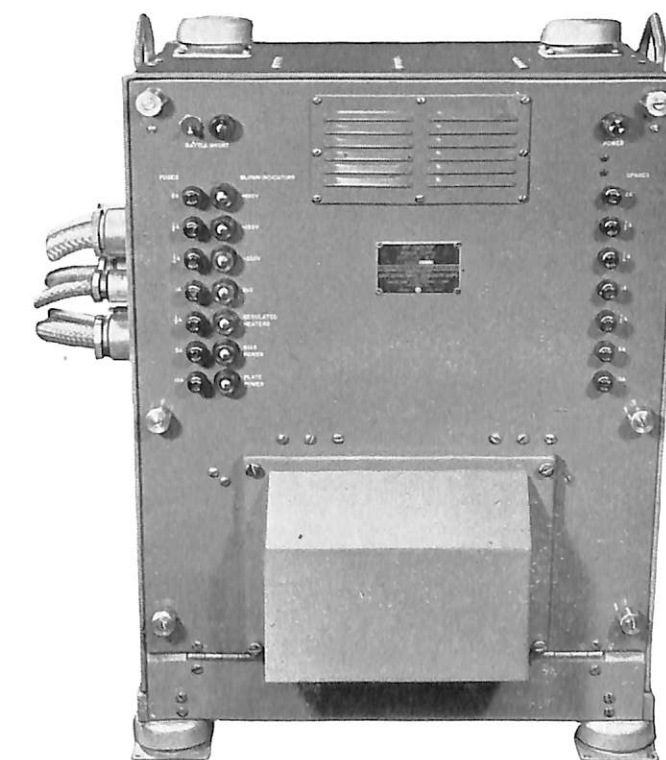
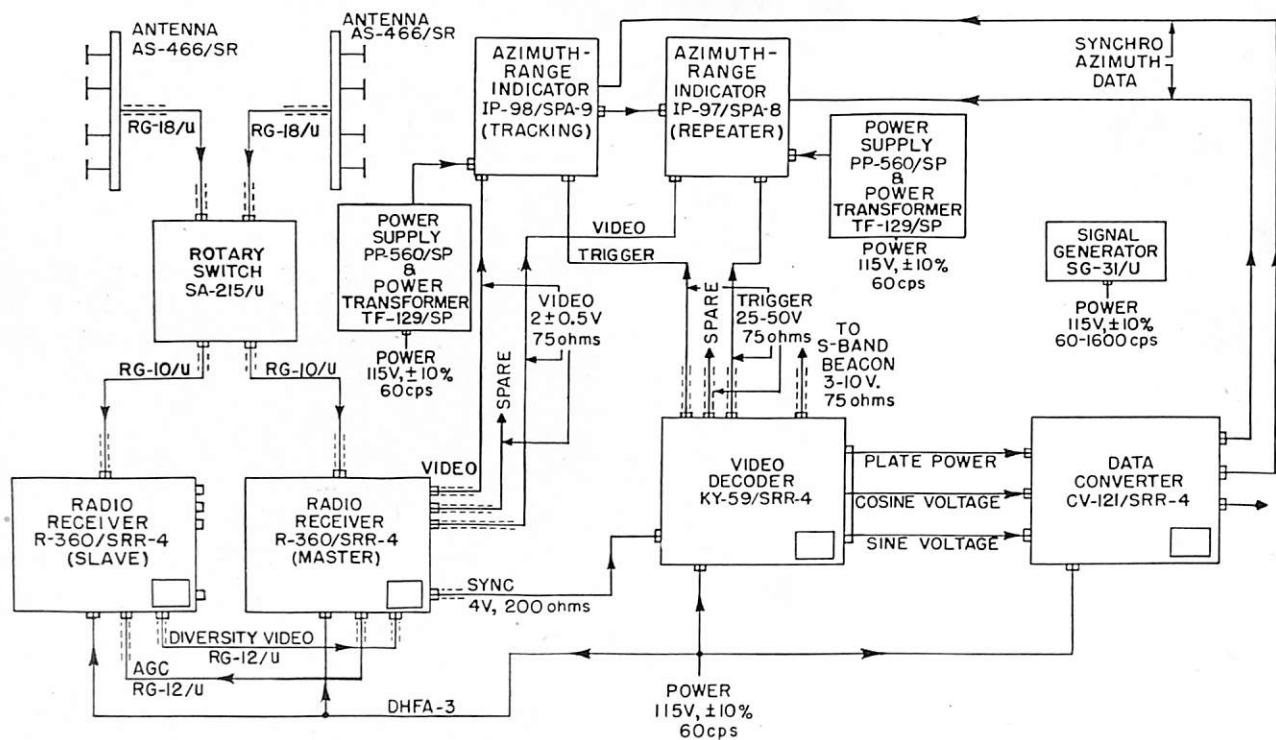

FIGURE 7—Power Supply PP-560/SP used with the Receiving Equipment AN/SRR-4.

cies from 60 to 1600 cycles. All units have their own power supplies, except the data converter which obtains part of its plate power from the video decoder.

FIGURE 8—Functional interrelation of individual components of the Radio Receiving Equipment AN/SRR-4.



The operation of the entire AEW system is shown in Figure 9. The AEW search plane carries search radar equipment of the AN/APS-20 series and also carries Relay Transmitter AN/ART-26 (which is to be replaced later by the AN/ART-28 now under development.) The antenna of the radar is highly directive in

the horizontal plane, having a beam width of only 31/2 degrees between half power points. This directivity plus the 1-megawatt power and the high elevation produce the excellent radar picture which is afforded by the AEW system.

Relay Transmitter AN/ART-26 receives its data di-

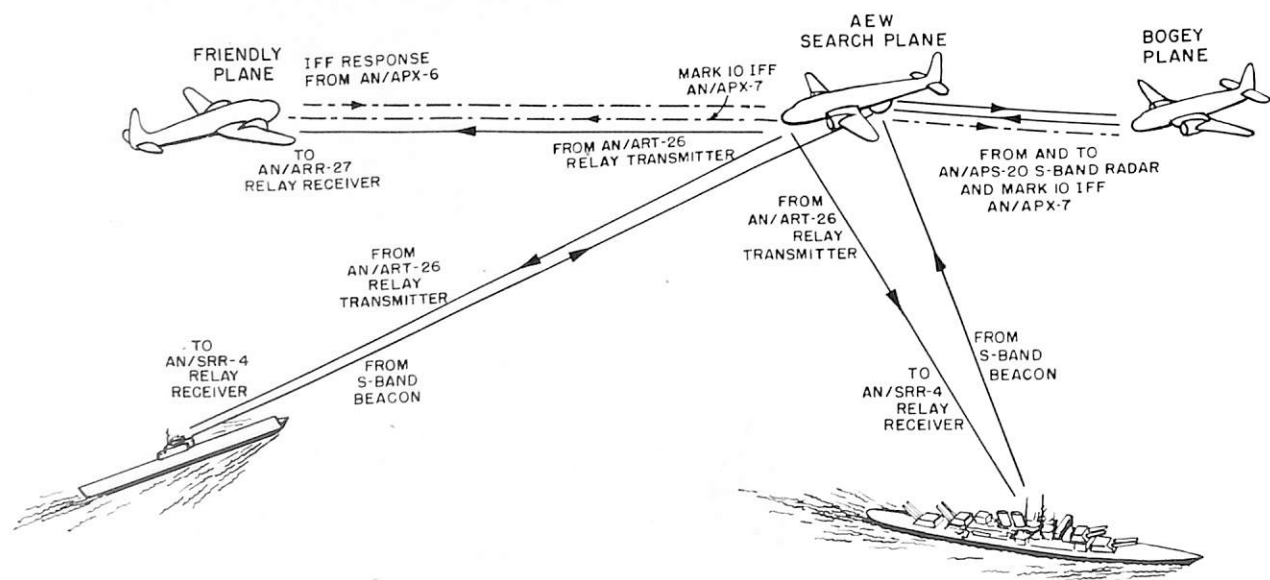

FIGURE 9—AN AEW system utilizing AN/SRR-4 equipment.



FIGURE 10—Radio Receiver R-360/SRR-4, one of two utilized in the Radio Receiving Equipment AN/SRR-4.

rectly by coaxial cable, and with these signals modulates a transmitter-oscillator in the 500-megacycle band. The intelligence is thus relayed to the AN/ARR-27 or the AN/SRR-4, or to both.

Shipboard installations in the AEW system include a beacon whose coded replies enable the surface operators to recognize their own ship on the display. This beacon receives enabling pulses from the AN/SRR-4 decoder and is triggered by the regular S-band radar pulses from the AEW plane whenever the antenna of the AN/APS-20 is directed towards the ship.

The search plane also carries a Mark-10 IFF inter-

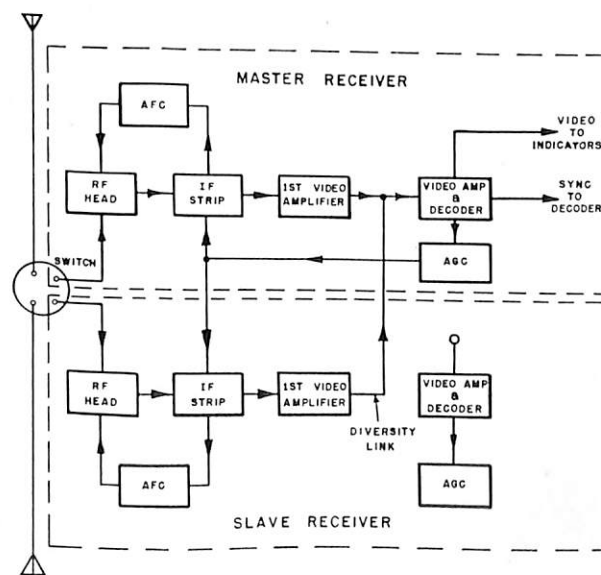

FIGURE 11—Simplified block diagram of two antennas and receivers operating in a diversity system.

rogator-responser (the AN/APX-7) which feeds information to the relay transmitter through the radar synchronizer on a time-sharing basis. In this way the

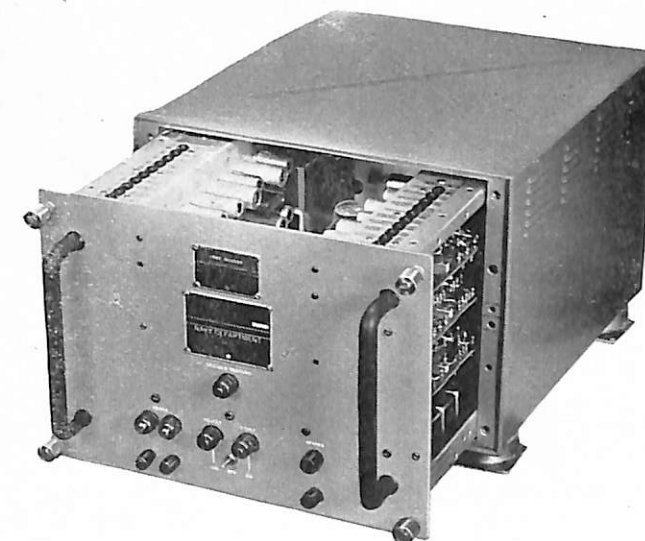

FIGURE 12—Video Decoder KY-59/SRR-4, a unit of the Radio Receiving Equipment AN/SRR-4.

video transmitted to the relay receivers includes both radar and IFF information.

Preceding Equipment

Following the use of the Cadillac equipment during World War II, the relay frequency assignment of about 300 megacycles was lost for military uses, and a change to about 500 megacycles was made. For this purpose the MX-851/SR Kit and Signal Fenerator SG-25/U were furnished. This signal generator, with the exist-

FIGURE 13—Time relationship between enabling gate, tracking gate, and synchronizing pulse in video decoder.

ing Video Generator 60ACY-1, constituted the available test equipment. It is from this basis that the new assignment has been designed. Carrier frequencies in the neighborhood of 500 megacycles have been retained, but numerous improvements incorporated.

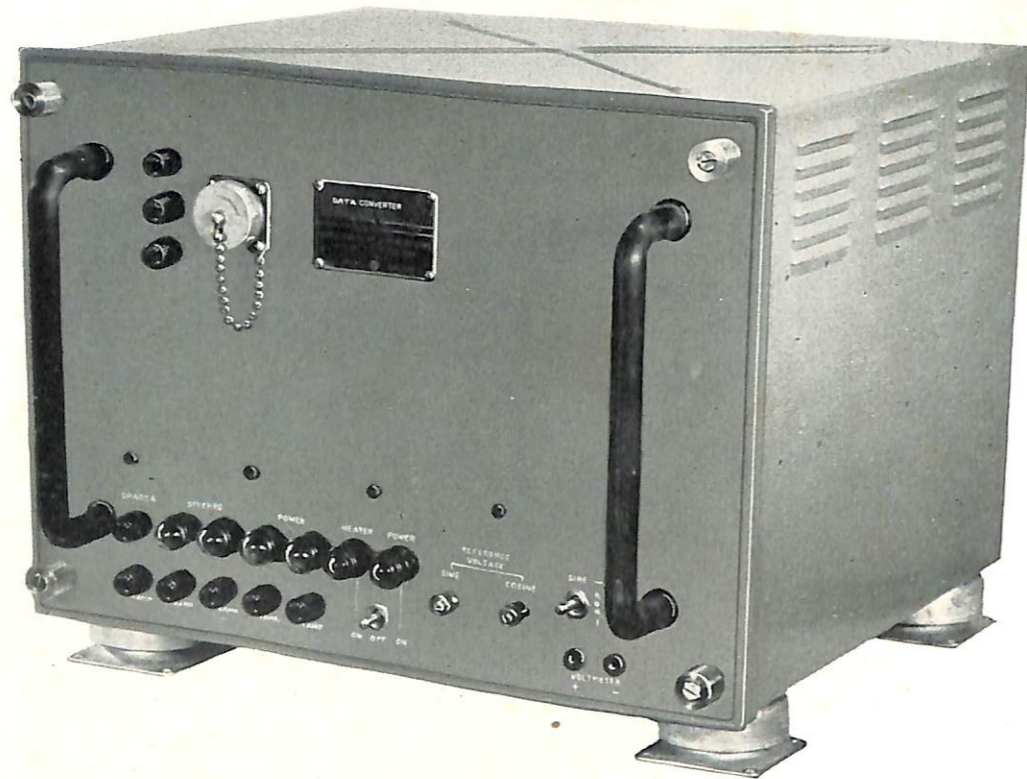

FIGURE 14 — Data Converter CV-121/SRR-4, a unit of the Radio Receiving Equipment AN/SRR-4.

Radio Receiver R-360/SRR-4

The receiver proper of the new equipment is shown in Figure 10. Circuits for decoding, sync separation, automatic gain control (AGC), automatic frequency control (AFC), and video amplification are included in this unit.

The r-f head is continually tunable and covers the four transmission channels of the airborne relay. Each channel is approximately four megacycles wide, and the center frequencies are separated about twelve megacycles. The receiver sensitivity is approximately 106 decibels below one volt, and normal video output to the indicators is two volts across a load of 75 ohms. The sync output to the video decoder has a normal amplitude of four volts across a load of 200 ohms.

Operation of two receivers together in a diversity system, each being fed by its own antenna through the antenna switch, is characterized by the combination of the outputs of the first video amplifier of each, as shown in Figure 11. Under these circumstances the gain of both receivers is determined by the maximum signal in either receiver. Noise which would be contributed by the set having the weaker signal is strongly discriminated against. The sync and video signal received by either receiver is handled by the video amplifier and decoder of the master receiver. The two receivers are on an equal footing with respect to which is acting and which is suppressed at any moment. The term "master" indicates the receiver which has its video amplifier, decoder, and AGC circuit always working in the com-

mon cause, while the "slave" receiver has these circuits inoperative.

The signal output of the i-f amplifier of each receiver is channeled into two different paths, one to the automatic-frequency-control (AFC) system and the other to the video circuits which handle the composite video signal.

Video Decoder KY-59/SRR-4

The video decoder obtains the sync pulses (basic, sine, cosine, and transmitter) from the master receiver R-360/SRR-4 and processes them into slowly varying dc voltages for delivery to the data converter. Output triggers to the PPI sweep and to AEW S-band beacon are also furnished. A view of a partially opened video decoder is given in Figure 12.

The input to the video decoder consists of sync pulses in decoded form. The decoder is prevented from being triggered by random pulses or spikes by virtue of enabling gates in whose absence the respective circuits are inoperative. Such an enabling gate for the sine circuit is present only if the immediately preceding basic pulse has been received. Likewise the cosine circuit is enabled only after receipt of the sine pulse, etc. Thus, abrupt variations in the output voltages, which would give rise to faulty operation of the data converter and the PPI rotation, are prevented. As shown in Figure 13, both a wide enabling gate and a narrow tracking gate are provided, the latter straddling the sync pulse and moving around with it inside the enabling gate. Unless both the wide and the narrow gates are present, no triggering

can occur (except when the video decoder operates in its sync-seeking mode).

While the video decoder is properly tracking sync signals, a relay is energized, closing a set of contacts in series with a pilot light on the front panel, thereby giving an indication of proper synchronization. If for any reason synchronization is lost, this relay will be de-energized and the pilot light will go out. At the same time

them into standard synchro data. The panel and cabinet of the data converter are shown in Figure 14.

The sinusoidally varying d-c voltages are converted into 60-cycle square-wave d-c voltages by means of two dual-diode switching bridges, and the two bridge outputs are applied to the stator winding of a two-phase control transformer on a scanner assembly. The error voltage from the control transformer is then amplified



FIGURE 15 — Signal Generator SG-31/U used with the Radio Receiving Equipment AN/SRR-4.

the video decoder automatically switches over into a different mode of operation, in which the narrow tracking gates are replaced by dc voltages; thus sync pulses are temporarily enabled to trigger the decoder irrespective of their position in time. As soon as synchronization is regained, the decoder automatically resumes its normal mode of operation, with the wide and narrow gates preventing faulty triggering. The relay then is energized and the pilot light again illuminated.

The output voltages which the video decoder furnishes to the data converter have a d-c level of about 110 volts, and peak amplitudes about the d-c level of approximately 60 volts. The frequency, corresponding to the rotational speed of the AN/APS-20 antenna, is about 0.1 cycle per second.

Data Converter

The function of the data converter is to receive the slowly varying d-c sine and cosine voltages indicating the azimuth of the airborne radar antenna, and convert

and applied to a servo motor. The servo amplifier includes the improvements of an anti-hunt circuit and of a phase-shift circuit producing a small amount of lead. By adjusting the amount of this lead to cancel the lag present in other parts of the system, the overall phase error of the system can be brought to zero. A 6G synchro generator, which is geared to the control transformer, delivers output which is standard 60-cycle 90-volt synchro data for control of the two PPI's of the system or other indicators aboard ship.

The data converter obtains the regulated part of its plate supply from the video decoder. This arrangement has the advantage that the reference voltages within the data converter are derived from the same supply voltage which was used in producing the sine and cosine voltages supplied as signal input. Error which might otherwise be introduced is thereby avoided.

Signal Generator SG-31/U

Complete test facilities for the AN/SRR-4 and the AN/ARR-27 are furnished by means of the SG-31/U.

which is shown in Figure 15. This consists essentially of a Video Generator 60ACY-1 and an R-F Generator SG-25/U with the added feature that the video wave from the former can be used to modulate the latter. With the SG-31/U, the overall performance of the relay receivers can therefore be readily observed, as well as tests made on the various individual components of the system. In order to be usable in airborne installations, its power-supply circuits have been designed for supply frequencies from 60 to 1600 cycles per second.

The pulse repetition rate of the SG-31/U is continuously variable in two ranges from 150 to 660 pulses per second. Each repetition cycle consists of the basic, sine, cosine, and transmitter pulses, followed by 50 miles of noise, a 100-mile gate (simulating 100 miles of video), and another 50 miles of noise. Sine and cosine pulse spacings corresponding to any produced by the AEW airborne synchronizer are generated by means of a sine potentiometer which may be manually set to any antenna angle or continually changed by a motor driven mechanism to simulate antenna scanning of an AN/APS-20. The synchronizing pulses are formed in groups, each having three pulses with three and five microseconds spacing, as in an AEW transmission.

Video output from the SG-31/U is available with synchronizing pulses either uncoded or coded, i.e., in either triple-pulse or single-pulse form. Output of RF is available with either complete AEW modulation, or CW. The frequency range is from 345 to 525 megacycles in a single band. The power output is continuously variable from -110 dbm (decibels below one milliwatt) to +13 dbm, into a 50-ohm load, the power being expressed in terms of peak sync level. The calibration of the piston attenuator is correct within one decibel over the entire range of 123 db. A precision calibrator for maintaining accurate attenuator calibration is also provided.

MARINE GCI SQUADRON FIVE REPORTS

Marine GCI Squadron Five, Cherry Point, N. C., wishes to report on several AN/TPS-1B maintenance problems which might be of interest to other activities:

1—The upper antenna gear train in Field Change #11 (MX-834/TPS-1B) should be drained, flushed and refilled with oil after several hours of operation. The presence of metal particles in the oil due to "wearing-in" of the gears causes intermittent binding in the gear train. This is reflected in objectionable voltage changes due to loading of the power supply generator.

2—Transporting the AN/TPS-1B radar unit causes bubbles to form in the mercury delay line which results

in several hours delay in getting satisfactory operation after the unit is again set up.

3—Careful cleaning of the fingers of the TR tube (1B23) with a rubber eraser is recommended prior to installation. This eliminates any tendency for arcing and resulting interference.

4—The governor assembly on several power units (PU-51) have been found unsatisfactory due to their lack of quick response to changes in load. This usually results in failure of the generator to put out the required voltage and frequency.

5—Care must be taken to insure that the local oscillator is tuned *above* the carrier frequency to obtain proper operation of the AFC unit.

SV/-1 MODULATION NETWORKS

Various instructions pertaining to replacement and disposition of defective SV/SV-1 radar modulation networks are reviewed to inform all concerned.

The Navy Type -53347 networks originally supplied in SV/SV-1 radars and associated repair parts were found to be defective in operation. Replacement of the Type -53347 is made with a new and improved network known as Navy Type -53347-A. All the Type -53347-A networks bear serial numbers of 1000 and above. This new network can be repaired and the contractor will repair any of this type that fail.

The Navy Type -53347 networks, which bear serial numbers below 1000, cannot be repaired by the contractor. However, the Bureau of Ships has committed all defective networks of this type to the Atomic Energy Commission. It is, therefore, necessary that the Bureau of Ships, Code 882, be advised whenever any defective SV/SV-1 networks, either NT-53347 or NT-53347-A, are available for disposition.

It is also imperative that the Bureau of Ships, Code 983, receive failure reports on all defective networks. This report should indicate the type and serial number, life hours, and a brief description of the failure.

SG-1B—F.C. NO. 63 BULLETIN ERROR

The following error has been noted in the Field Change Bulletin (NavShips 98084) for Field Change Number 63—SG-1b:

In Figure 5, Page 4, E-946 should be changed to E-926.

Something troubling you? Send it to "Letters to the Editor" and try and stump him!!



MARK 25 MOD 2

ATI Circuit Maintenance

When stationary targets were placed in the range notch and foot switches depressed to place the system in "track" condition, the antenna would immediately elevate and train to the left (i.e. director) thus losing selected target(s). Equipment would not track consistently in range. When the signal slewed out of the notch with the system in "track" condition, the ATI relay "drop out" varied from approximately 10 to 20 seconds. This meant that the system would stay in "track" with no signal in notch. (Noted signal had tendency to run out of right-hand side of notch after being gated.)

The following checks were made to determine cause of instability of director system to lock on targets.

- 1—Antenna rotation—CCW from front.
- 2—Target sense.
- 3—Aligned tracker.
- 4—Checked director operation in full automatic control. Found T & E signals from computer were normal. This eliminated director and computer fire control circuits
- 5—Checked external wiring of 6DG synchros at tracker and found everything normal.
- 6—Checked all train and elevation error signal leads between tracker and unit assembly.
- 7—Checked all T & E error detector tubes.

Finally reversed antenna rotation (now running clockwise from front) and found system tracked normally. With this in mind the internal connections of the 2-phase generator were investigated and found to be reversed. Reversed phasing of 2-phase generator (G1) at TB1. (leads 7 and 9, and 8 and 9). Then reversed antenna motor at motor controller (feedhorn running

CCW from front). After these adjustments the system would run normal in train and elevation.

Found a standard 6-amp fuse being used instead of a 5-amp Fusetron in F(14)15 and F(15)15. Both were replaced with 5-amp Fusetrons. The tension on the ATI relay spring had been adjusted which necessitated a check on this spring to insure that values were correct. These checks consisted of the following:

- 1—ATI "pull-in" voltage found to be +95 volts.
- 2—ATI "drop-out" voltage found to be +32 volts.

Corrected spring adjustment and obtained the correct values as follows:

- 1—ATI "pull-in" voltage +63 volts.
- 2—ATI "drop-out" voltage +25 volts.

After these adjustments had been made the ATI relay operated correctly. There is no longer a delay in opening when signal slewed out of notch.

The signal had a tendency to run out of the right-hand side of the notch. It was noted that the 30-cycle voltage in TP-14 when test 2 switch was depressed, had an abnormally large amplitude before a balance was reached. A check disclosed the waveform at TP-10 was incorrect. Replaced V(12) 4, 6, 17 and 19. 30-cycle amplitude at TP-14 was then found to be normal and the target would no longer run out of notch.—T. R. TRIPLETT, W. S. MCLEAN and E. F. WOOTEN, *ComServLant*.

CORRECTION

On Page 21 of the November BU SHIPS ELECTRON, the items about the U.S.S. Epperson (DDE-719) should have been listed as applying to the Mark 34 Mod 2 instead of the Mark 25 Mod 2.



Since Radar Equipment Mark 12 is rapidly being replaced with Radar Equipment Mark 25, an X-band radar, it has been necessary to develop an X-band beacon for use with the new radar as a reference point for shore bombardment purposes. The X-band beacon program dates back to World War II. The Bureau of Ordnance at that time had under development at the Radiation Laboratory, Massachusetts Institute of Technology, an X-band fire control beacon known as the Mark 6. This program was cancelled at the close of the war when it was decided that efforts should be directed toward the development of a more universal beacon for general use. Because of the delays encountered in attempting to incorporate all of the requirements necessary to provide an ultimate universal beacon, it was decided that the Bureau of Ordnance should provide the Marine Corps with a suitable interim beacon for training purposes. The AN/TPQ-7 beacon is intended to serve this purpose.

The Radar Beacon AN/TPQ-7 is an interim X-band beacon designed primarily for use with fire control Radar Equipment Mk 25 in the control of ship-to-shore gunfire. With the exception of the coder and duty cycle limiter, the basic circuits of the transmitter-receiver and power supply were developed by the Naval Research Laboratory and first incorporated in Radar Set AN/

DPW-2 built by Gilfillan Brothers. The Naval Ordnance Plant, Indianapolis, modified the basic circuits by the addition of a coder, a duty cycle limiter, and an antenna assembly, and mounted the units in watertight cases suitable for transportation on pack boards. Figure 1 shows the beacon assembled for operation. A carrying case is provided for transporting the folded antenna assembly, power cables and ground lead. Figure 2 shows the units packed in their watertight cases, ready to be secured to the pack boards. Figure 3 shows the receiver-transmitter and antenna case lashed to a pack board. The primary source of power for the beacon is a 120-volt, 400-cycle, 400-watt generator driven by a Lawson-Atlas gasoline engine (Figure 4) similar to the one provided with the MAR equipment now in use by the Marine Corps.

The Radar Beacon AN/TPQ-7 utilizes a 2J41 magnetron operating on a transmitting frequency of 9310 megacycles. The receiver frequency is stabilized so that the beacon will be triggered only by a signal of 9280 Mc. The 2K25 local oscillator is stabilized by means of a 1Q22 fixed tuned cavity and AFC unit at 9250 Mc. ± 0.75 mc; the i-f frequency is 30 Mc. The two horn-type antennas, one for receiving and one for transmitting, have identical beam patterns of 60° in the vertical plane and 120° in the horizontal plane as measured at the 0.1 power point of the one-way pattern. Other electrical characteristics of the beacon are as follows:

Antenna gain	15 db
Output power	300 watts peak
Pulse length	0.5 microseconds
Duty cycle	0.003
Receiver sensitivity	not less than -45 dbm
Receiver selectivity	over-all band width greater than 6 mc.

In order to identify a particular beacon reply, any one of four multiple-pulse coded replies may be selected by the beacon operator as indicated by the tactical employment of the beacon. In Code 0 the beacon responds with a single pulse only. A duty cycle limiter is incorporated to maintain the operation of the magnetron within its duty cycle when operating with more than one Radar Equipment Mk 25. It is anticipated that the count-down resulting from operation with up to four Radar Equipments Mk 25 will not seriously affect automatic tracking.

A 6E5 "magic eye" tube is provided for indicating that the beacon receiver is being triggered. The indicating device may also be used to orient the antenna in the proper direction for maximum received signal strength from the ship's radar. A neon bulb is provided to check the operation of the transmitter. Two storage chests are provided to house each beacon, including its first and second echelon spare parts and instruction books.

FIGURE 1—Radar Beacon AN/TPQ-7 assembled and ready for operation.

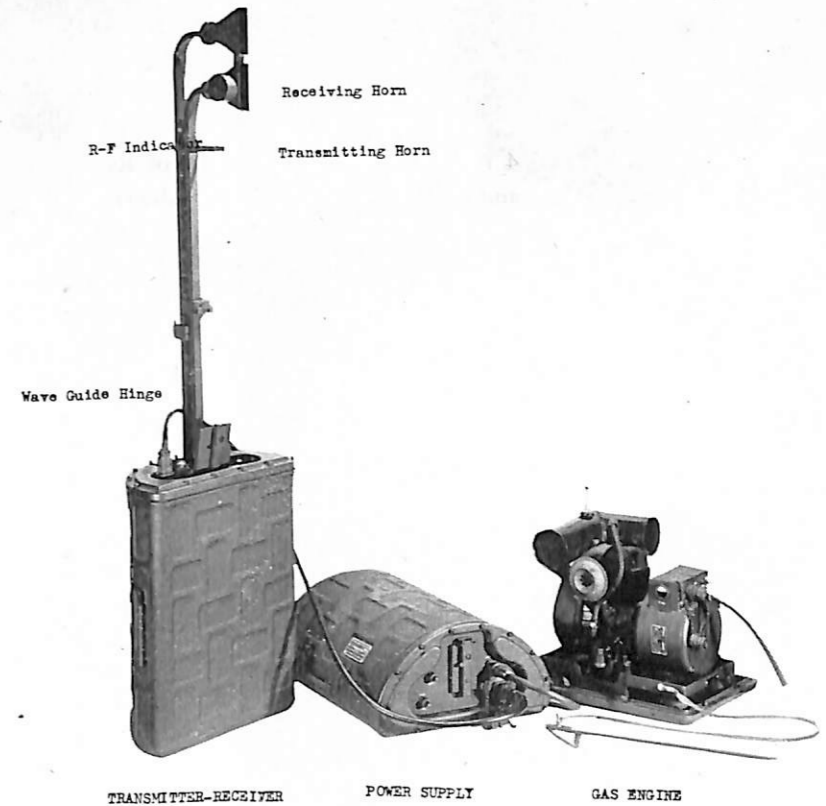

The beacon has been designed for minimum maintenance and adjustment in the field. Only two operating controls, a power on-off switch and a code selector switch, are provided. Spare fuses are housed in a watertight compartment on the outside of the power supply unit. A limited number of spare tubes are housed in sockets on a panel within the power supply unit.

In order to trigger the beacon at 9280 Mc. with Radar Equipment Mk 25, the radar transmitter must previously be set at that frequency, using a TS-35/AP test set. The radar local oscillator must then be tuned to receive the beacon frequency, 9310 Mc. Since the 2K45 local oscillator in the radar is a thermally tuned tube, it does not lend itself to rapid, accurate manual tuning. Tests

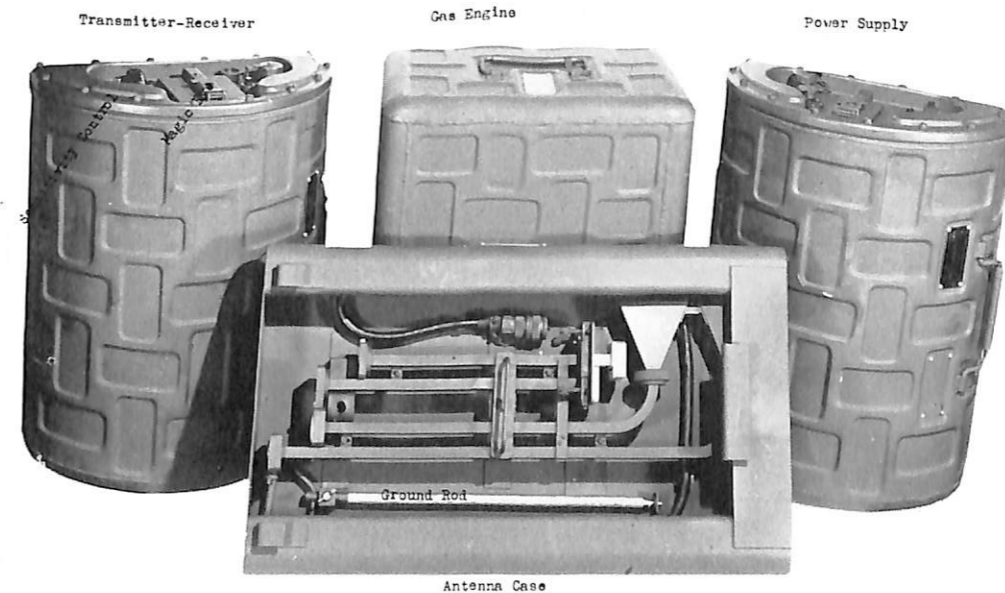

FIGURE 2—Four major components of the Radar Beacon AN/TPQ-7 in metal cases ready for packboard mounting.

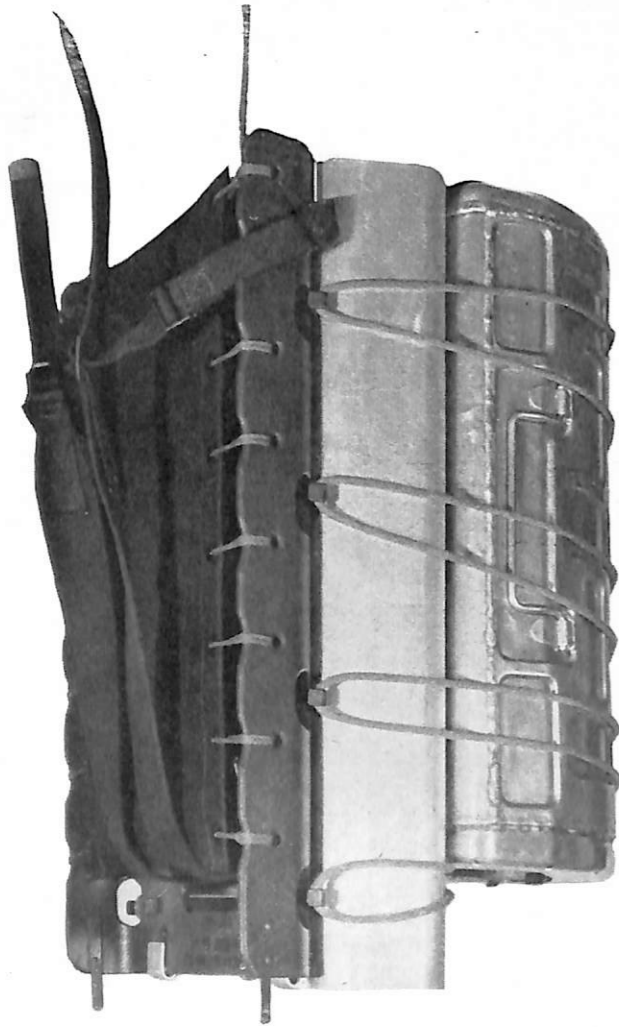

FIGURE 3—Antenna case and transmitter-receiver of Radar Beacon AN/TPQ-7 mounted on packboard for carrying.

showed that it would be impractical to expect the radar operator to manually tune the local oscillator to receive the beacon signal and keep the received signal at its maximum strength at all times.

Field Change No. 28 for the Radar Equipment Mk 25 has, therefore, been designed to stabilize the radar local oscillator at 9250 Mc. ± 0.75 Mc. for beacon reception by means of a reference cavity. This field change provides a new local oscillator mount with a directional coupler reference cavity and beacon AFC crystal holder attached. A new beacon AFC chassis is mounted in the Mk 25 Mod 2 transmitter near the present AFC unit. A radar-beacon switch and its associated relay provide the necessary switching functions for quickly switching from radar to beacon operation, and vice versa. Preliminary models of the beacon AFC unit for Radar Equipment Mk 25 utilize a 1Q22 fixed tuned cavity for

use specifically with Beacon AN/TPQ-7. The production models for the radar beacon AFC unit will be provided with tunable cavities in order that the radar will operate with the tunable beacons of the future. Figure 4 illustrates the operation of Radar Equipment Mk 25 and Beacon AN/TPQ-7, showing the various frequencies employed.

Operational tests to evaluate the use of the Radar Beacon AN/TPQ-7 in conjunction with Radar Equipment Mk 25 primarily to aid in the control of Naval gunfire have recently been conducted by the Naval Amphibious Test and Evaluation Unit, Little Creek, Virginia, with the *USS Des Moines (CA-134)*, *USS Gearling (DD-710)* and *USS Gyatt (DD-712)* participating. Four pre-production Beacons AN/TPQ-7 and four preliminary field changes to the associated radars were made available for this purpose. The suitability of the Radar Beacon AN/TPQ-7 as a shore fire control beacon was determined to be dependent upon: (a) its ability to be readily located over a wide sector of operation and to the maximum range of the radar with no accompanying land echoes; (b) its ability to be distinguished from other beacons in the vicinity; (c) its ability to provide a suitable tracking point for either automatic or manual operation of the fire control radars; and (d) its durability, transportability, etc., in operation and maintenance. The feasibility of utilizing the beacon to establish reference points on shore and off shore to aid in the control and guidance of landing craft and vehicles was also investigated. The official report of the operational tests is not yet available, but observations made by Bureau personnel at the tests indicated that the beacon satisfied operational requirements. Saturated beacon sig-

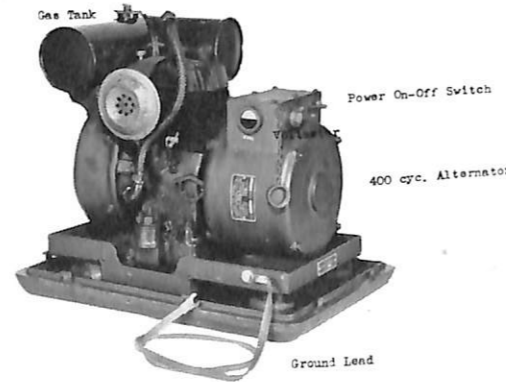

FIGURE 4—Gasoline engine with 400-cycle alternator which supplies the power for operation of the Radar Beacon AN/TPQ-7.

R. E. MK. 25
(ON SHIP)

BEACON AN/TPQ-7
(ON SHORE)

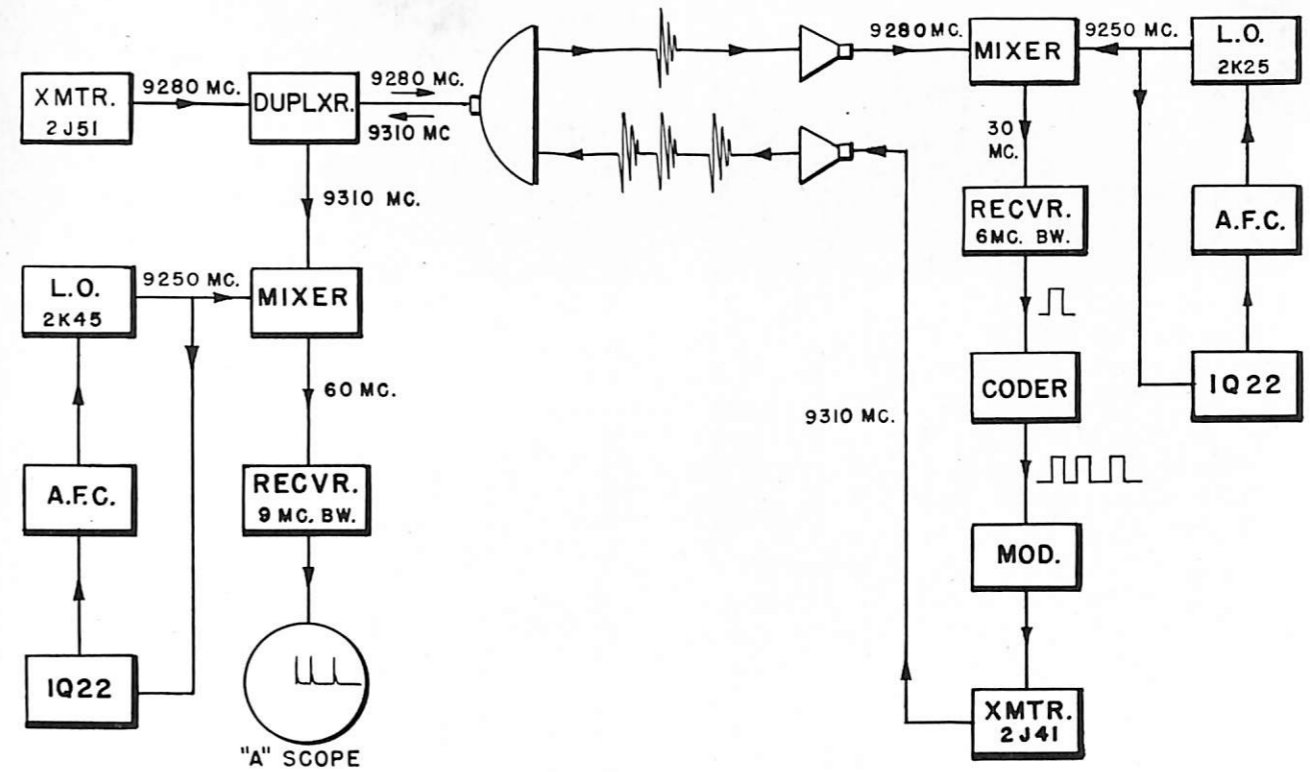

FIGURE 5—Block diagram showing relationship between the Radar Equipment Mark 25 and the Radar Beacon AN/TPQ-7, as well as the signal flow in the Radar Beacon AN/TPQ-7 and Radar Equipment Mark 25.

nals were reported at maximum ranges of the radar equipment. Discrimination in both range and bearing was comparable to that obtained during normal radar operation. The coder provided a coded reply which could readily be distinguished from other targets. Four Radar Equipments Mk 25 automatically tracked one beacon when the beacon replied with a single pulse code. When the beacon was responding with a coded reply of two or more pulses, count-down and interference were sufficient to make automatic tracking difficult with more than three radars. However, the four radars used in the

test could manually track one beacon with a coded reply. A few shortcomings and malfunctions were observed and these are expected to be corrected in production models.

Present plans call for the procurement of 35 Radar Beacons AN/TPQ-7 for use by the Marine Corps. Modifications are now being made to incorporate the changes deemed necessary as a result of the evaluation tests. It is anticipated that the production models will be available in the fall of 1950.

—BuOrd Bulletin of Ordnance Information

ANTENNA GROUP AN/SRA-3 I.B. CORRECTION

The Electronics Supply Office reports that NAVSHIPS 91292, the Instruction Book for Antenna Group AN/SRA-3, Section 5, Parts List, Table 5-1, List of Major Units, should read as follows:

Symbol Group	Quantity	Name of Major Unit	Navy Type	Standard Navy Stock Number
	1	Antenna Group	AN/SRA-3	F16-A-54463-5300
101-199	1	Antenna	AT-252/SR	F16-A-54463-5150
201-299	1	Antenna Coupler	CU-226/SR	N16-C-91727-9345



The CLC-1 Task Fleet Flagship was conceived by the Navy's Ship Characteristics Board as an entirely new kind of Naval vessel to transport, maintain, and provide facilities for the exercise of command functions over a Joint Expeditionary Force or Fleet. The concept behind the CLC-1—that of a major fleet ship having no other mission except to serve as a floating nerve center for a complete Task Force—marks a distinct break with Naval tradition. Even the armament of the CLC-1 has been reduced to the minimum necessary for defensive purposes only; and this armament has been further subordinated by such limitations as the restricting of the arc of fire wherever it interferes with the effective accomplishment of flag functions.

The procedure in planning and designing the CLC-1 also represents a new departure from tradition. For the first time in Naval shipbuilding history, the electronics engineer is being given an important part in the initial planning of a major vessel—with authority, in effect, to write his own ticket. Instead of having to fit individual equipments into whatever space is left after the rest of the ship is built, he is being given the opportunity to incorporate into the original ship design such complete and integrated electronics systems as he believes are necessary to meet the needs of future warfare. The result of this design approach will be the utilization of electronic devices to an extent never before attempted on any ship.

The CLC-1 Task Fleet Flagship will be built on the hull of a CA-122 class heavy cruiser. The ship will be 664 feet long, and will have a beam of 71 feet and a draft of 25 feet. It will be ruggedly constructed and will have transverse stability under all conditions of loading. Its endurance will be 7000 miles at 20 knots, and, except for the elimination of the armored conning tower and tube, armor protection will follow the standards established for heavy cruisers. Armament will be four 5-in/54 twin mounts, four 3-in/70 twin mounts, and twelve free-swinging machine guns. Two helicopters will be carried.

Command facilities will include two tactical plotting rooms—a flag tactical plot and the commanding officer's

* * * * *

CLC-1 TASK FLEET FLAGSHIPS ANTENNA SYSTEMS DESIGN

by
U. S. Navy Electronics Laboratory
San Diego, California

tactical plot. The flag plot will be located on the flag bridge, from which the OTC can effectively exercise tactical command. It will be equipped with radar display, summary and graphic plots, remote radio controls for tactical purposes, primary and secondary strategic plots, tactical surface plot, vertical and summary plot, DRT, combat intelligence plot, fleet fighter director station, and voice circuit recorders. The commanding officer's tactical plot will follow standard practice, and a joint operations room will be equipped with facilities to exercise command over all assigned forces.

Located close by the commanding officer's tactical plot will be the command operations center, a communications filter room, and a combat intelligence room. The COC will be equipped for display and summary plot of necessary information acquired from air and surface radar, radio, and other sources. Included in its facilities will be aircraft-early-warning radar terminal equipment. The combat intelligence room will contain facilities for collecting, evaluating, and disseminating all combat intelligence.

AT THE TOP OF THIS PAGE—Profile view of 1/48-scale model of proposed CLC-1 Task Fleet Flagship.

In remaining protected locations aboard the ship will be radio rooms, a sonar room, a communications office, code rooms, a strategic intelligence room, a joint planning office, a troop conference room, a radio intelligence room, and other special-purpose offices and rooms. Radio rooms I, II, and III will be equipped with radio transmitting and receiving equipments adequate for the needs of the task fleet commander. The sonar room, located below-decks, will be equipped with scanning sonar and a sonar receiver. Countermeasures facilities will include equipments for intercepting, analyzing, and, if necessary, jamming enemy radar, communications, and guided missile control signals.

The design and development of the multiplicity of electronic equipments on the CLC-1—detection, ranging, communications, navigation, and countermeasures—is involving the efforts of a large number of the Navy's development activities. Included among these is the Navy Electronics Laboratory. NEL's participation in the design program was begun early in 1948 with a study

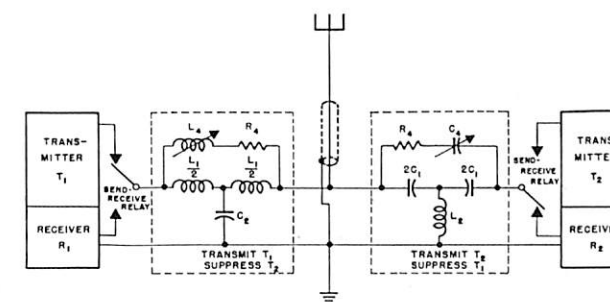

FIGURE 1

of the effects of the original superstructure on the directivity of communications antennas.¹ This program has since been extended to include the designing of the overall communications system of the ship. The program

¹ NEL Report No. 118 CONFIDENTIAL). *Directivity Effects of Superstructure on a Proposed Task Fleet Flagship (CLC-1) Determined by Ship Models (Final)*, by V. C. Smith and H. J. Bootman, 13 April 1949.

is now nearing completion, with delivery of the final plans for the system scheduled for 1 January 1950.

The Antenna Problem

The principal problem confronting the NEL engineers was the design of the antenna system for the CLC-1. From the very beginning of the study, it was apparent that there were simply not enough good antenna locations on the CLC-1 to take care of the number of channels requested by the Chief of Naval Operations. The original study of the directivity effects caused by the proposed superstructure of the vessel had indicated that the forward tower, the stack, and the mainmast caused pronounced undesirable directivity in the lower and important portion of the 2-to-20 Mc range. A number of remedial modifications to the design of the superstructure were proposed, and part of these—such as a revision of the original rigging specifications—were adopted. However, even with these alterations, the number of suitable antenna locations was still far below the desired minimum. Thus, at the outset, a compromise was necessary, involving a reduction in the number of channels required to provide what CNO had decided were necessary facilities for the vessel.

With the number of channels reduced to practicable limits, and the superstructure modified as far as could be done without impairing the other flag functions of the ship, NEL began work on an integrated antenna system design program. Simultaneous work started on: (1) calibration of the several usable antenna locations found previously in the directivity studies; (2) development of a single radiator for several transmitters or receivers; and (3) development of the best antenna types for both transmitting and receiving, consistent with location and frequency ranges to be accommodated.

Transmitting Antennas

One of the first steps taken by the CLC-1 task group was a model study to test and calibrate all of the usable antenna locations on the ship over the 2-to-20 Mc range. This study was conducted at the NEL model range, using the 1/48-scale model of the CLC-1 which had previously been employed in the study of superstructure directivity effects. The antennas used were 1-48-scale models of a trussed whip, a modification of the structure used for many years along the flight deck of aircraft carriers. Sufficient data has been obtained on this type of antenna to indicate that its characteristics make it suitable for a multipurpose transmitter radiator.

Successive directivity patterns were recorded for each of these antennas at each location, alone and in company with the rest of the antennas, one by one, until all were in place. The patterns were recorded at small intervals throughout the entire 2-to-20 Mc range. From these patterns, it was then possible to determine the position for any particular antenna which would permit the efficient

radiation of energy over any given portion of the communication frequency range, and, for each location, the frequency ranges over which optimum radiation could be expected.

Since, as has been stated, there were not enough acceptable antenna locations on the CLC-1 to go around, the second step in the design program was to find some means of using each antenna to radiate the power of several transmitters. This marks a considerable departure from convention. Previously, on shipboard, each transmitter has always had its own antenna. With the multiplexing systems proposed for the CLC-1, however, it is expected that one antenna will be used for as many as four transmitters. Thus, six or eight antennas will do the work that would formerly have required twenty to thirty installations.

One proposed transmitter multiplexing circuit, which has already undergone a number of tests, makes use of passive filter networks to isolate the transmitters from each other. The feasibility of using efficient filters for this purpose was first indicated by studies of tuning and loading conditions of Navy transmitters.² Obviously,

a very high degree of isolation is required, since there would be no point in simply substituting transmitter interaction for antenna interaction. Bridged-T and lattice networks were found to meet the isolation requirement. These circuits permit communication transmitters to be loaded properly and deliver high output at the operating frequency, but severely attenuate other frequencies. In fact, the attenuation is so great that it has actually been possible to operate a 1-kilowatt transmitter and a standard Navy receiver through these networks from a common antenna without affecting the receiver performance.

A number of successful tests have been made with a diplexing system using this type of filter to connect two Navy transmitters operating in the 2-to-18 Mc band with a common antenna (see Figures 1 and 2).³ For the proposed four-transmitter CLC installation, additional filters

²NEL Report No. 63 (UNCLASSIFIED), *Tuning and Loading Conditions in General Purpose Transmitters (Interim)*, by S. E. Parker, 20 July 1948.

³NEL Report No. 115 (UNCLASSIFIED), *A System for Multiple Operation of Radio Transmitters and Receivers (Final)*, by S. E. Parker, 1 July 1949.

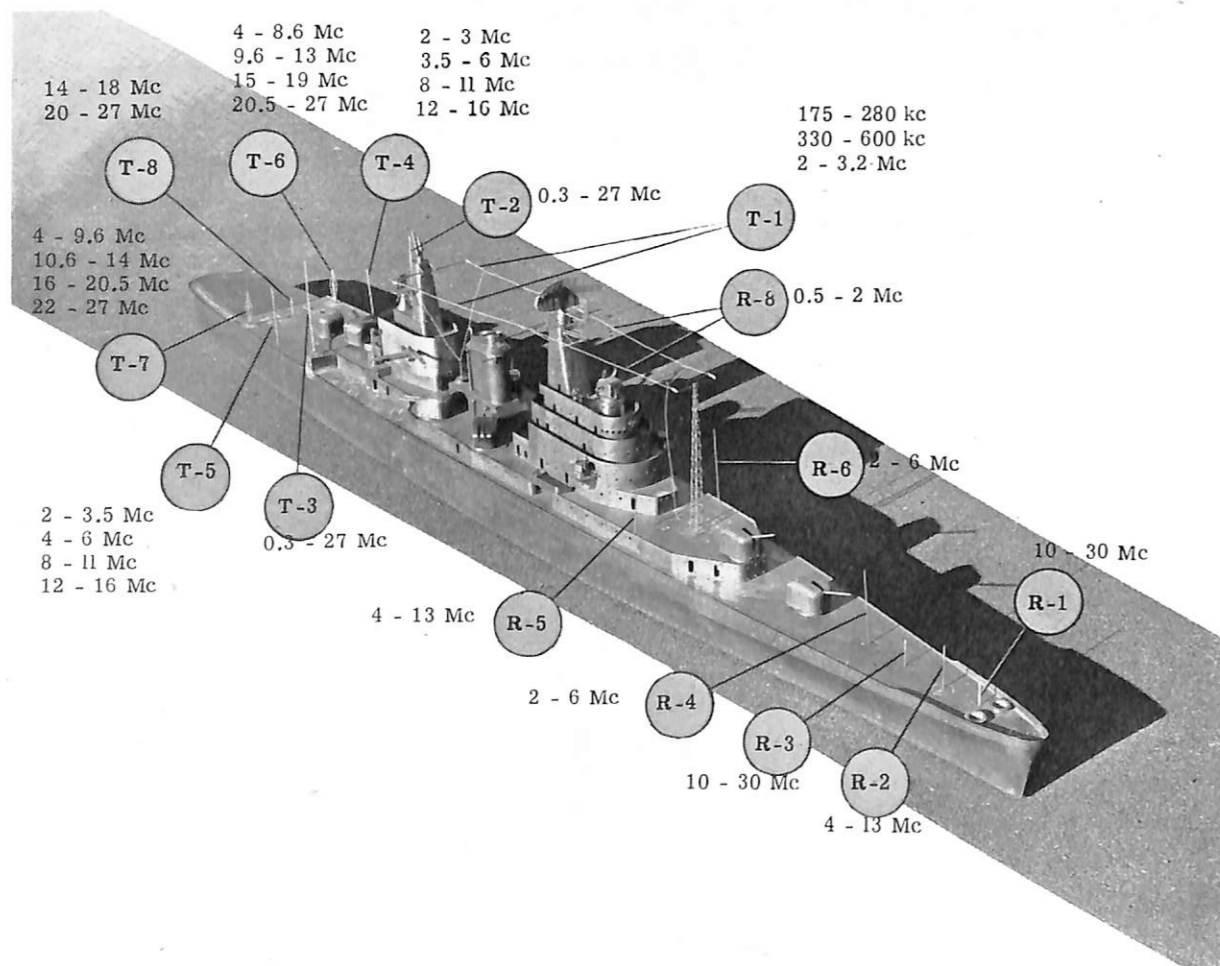

Aerial view of 1/48 scale model of CLC-1 Task Fleet Flagship, showing antenna system proposed as the result of the NEL antenna systems design study. Transmitting and receiving antennas indicated and recommended frequency bands for each shown.

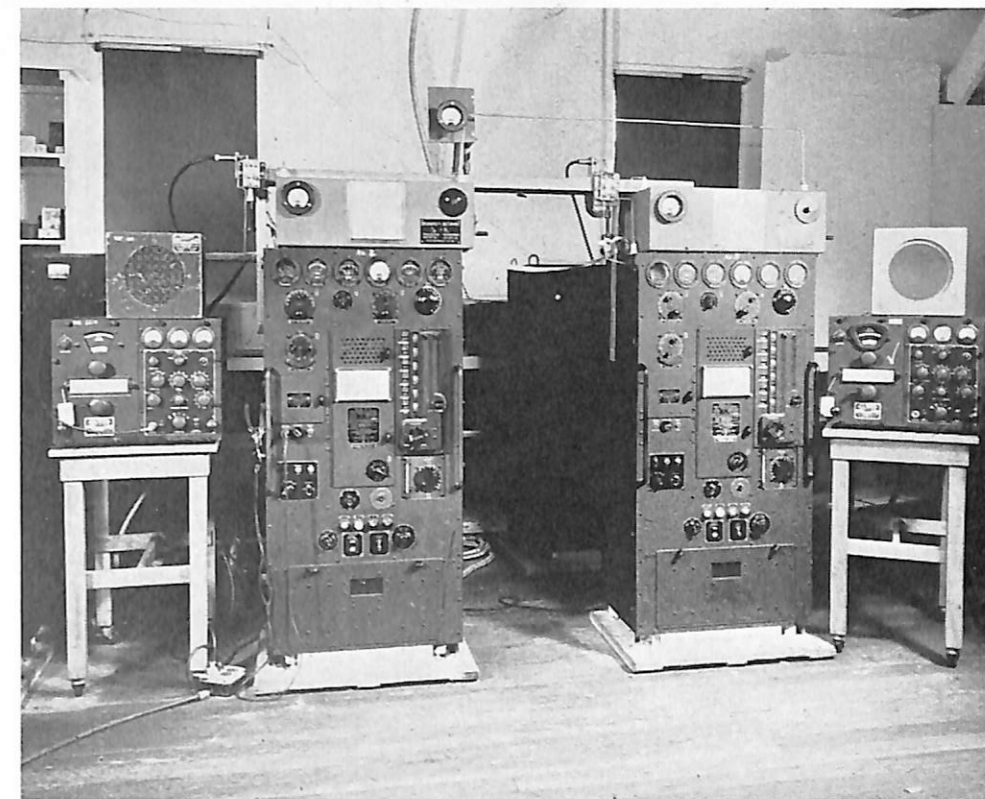

FIGURE 2 — Diplexing system using two transmitters and two receivers, successfully tested at NEL. (See Figure 1).

will be needed, connected as shown in Figure 3. This particular arrangement minimizes the amount of tuning necessary in shifting operating frequencies. While the capabilities of the system have not as yet been fully proved, tests results, made with resistive loads under idealized conditions have been very encouraging.

Another promising type of circuit for transmitter multiplexing is the CAW system proposed by the Naval Research Laboratory. This system is based on a method of coupling the output circuits of several transmitters to a common coaxial transmission line by means of a series of single-turn loops in the line. The performance characteristics of this system are now being compared with the characteristics of the system developed at NEL.

For practical multiplexing it is necessary, of course, to insure that the antenna will radiate efficiently at all

the different operating frequencies. In allocating available frequencies among these antennas, two major considerations must be taken into account; first, the 2-to-20 Mc range must be broken down into segments and each antenna examined for its ability to transmit efficiently over one or more of these segments; second, "guard bands" required for channel separations in the multiplexing system must be provided between segments.

Choosing the proper antenna location for any given frequency segment involves a survey of the antenna and their locations. This survey, as has been shown, was made for all the antenna locations through the use of the 1/48-scale model. For each of the antennas, there were found certain gaps in the pattern coverage. These gaps, made up of pattern irregularities, did not appear at the same frequency for all antennas. A single antenna, it

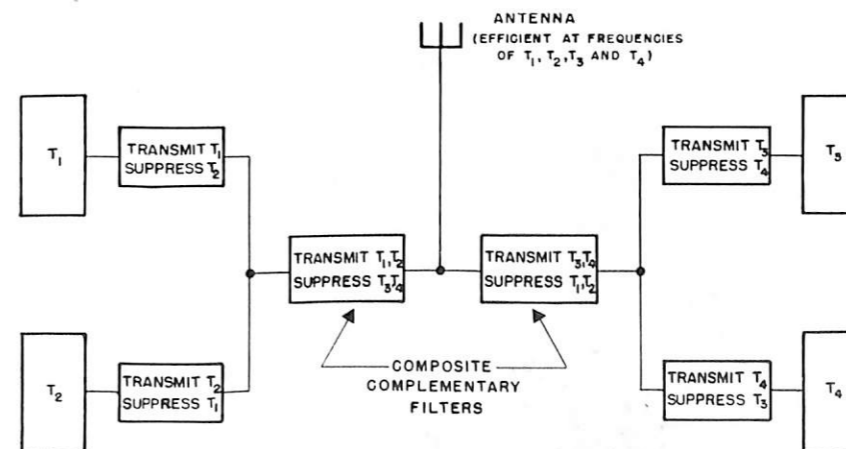

FIGURE 3

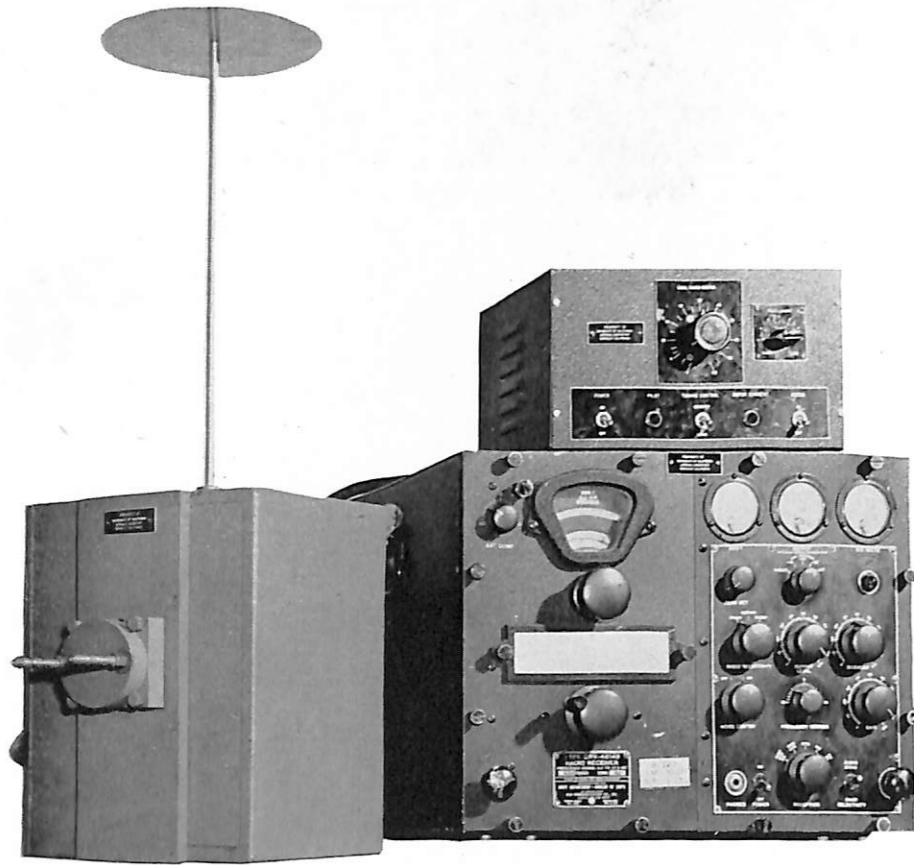

FIGURE 4 — Short, tunable monopole antenna, developed by University of California Radio Research Laboratory working in close cooperation with NEL. Also shown are receiver and remote tuning control.

was found, would exhibit acceptable omnidirectionality over the range from perhaps 2 to 4 Mc, become irregular or useless between 4 and 7 Mc, and again become acceptable between 7 and 20 Mc. Another antenna, at another location, would be inferior between 2 and 4 Mc, excellent between 4 and 7, poor between 7 and 20, and so on. With this information, the antenna design engineer could specify the actual frequencies over which each antenna would operate efficiently, and the designer of the multiplexing system could arrange to put his "guard bands" in those regions where the efficiency of the antenna was lowest.

Proper knowledge of the characteristics of each antenna and its location makes it possible to get the most out of each as a radiator of power. With this knowledge it is possible to avoid "hot" spots on coaxial transmission lines. It is also possible, with this knowledge, to operate transmitters at reduced power without reducing efficiency.

Although the trussed whip type of transmitting antenna was used throughout in the model studies of CLC-1 antenna location, several other types of transmitting antennas are also being considered for the actual shipboard installation. One of these types, a long-wire flattop radiator, will definitely be used.

Receiving Antennas

It may be shown that any antenna acting as a receiver of electromagnetic energy behaves exactly as does one which radiates electromagnetic energy. Thus, the positioning of a receiving antenna is fully as important as the positioning of a transmitting radiator if directivity effects are to be avoided. Like the transmitting radiator, the receiving antenna is affected by nearby metallic objects to such an extent that lobes and nulls occur at certain frequencies. Thus, like the transmitting antennas, patterns must be taken of each receiving antenna at each position to determine how best to utilize these antennas throughout the communications frequency range. Based upon the information contained in the patterns, receiving antennas may then be allocated so as to perform most efficiently at particular frequencies or segments of the 2-to-20-Mc spectrum.

Unlike transmitting antennas, receiving antennas may be easily connected to a random number of receivers. Problems of receiver multiplexing, however, differ in several respects from the transmitter case. Receivers must be capable of being tuned rapidly and easily over a very wide frequency range. This rules out certain methods employed in transmitter multiplexing. On the other hand, since the amount of power involved in reception

is small, the use of active networks—those employing vacuum tubes—may be feasible for purposes of isolation.

No completely satisfactory plan for receiver multiplexing has yet been devised. It is apparent, however, that improvements over present Navy practice are possible. Today, from ten to twenty receivers are generally operated from a single untuned antenna by means of simple parallel connections across the transmission line. Very inefficient performance usually results. Signal losses as high as 60 db are often encountered, particularly at low frequencies such as 15 kc. Impedance mismatches and absorption of power by other receivers in the string result in an unfavorable signal-to-noise ratio.⁴

Several methods of attack on this problem have undergone investigation during the past year. In one of these methods, receivers are isolated from each other and from the common line by means of a vacuum-tube device called the "multicoupler." Properly designed multicouplers can provide excellent isolation. They have, however, certain inherent defects. When used with well-designed receivers, the signal-to-noise ratio is decreased. They are prone to the creation of distortion, particularly spurious response and cross-modulation. They are also subject to blocking, so that weak signals will sometimes be lost in the presence of strong ones. Of several commercial multicouplers tested, two have been found to have features of merit—a unit developed by the Airborne Instruments Laboratory,⁵ and one known as the Signal Corps 52XC.⁶ Although both these multicouplers, and particularly the AIL unit, are satisfactory in moderate interference fields (less than 0.01 volt at input to multicoupler), neither one is free from the effects of spurious response.

A second multiplexing method investigated makes use of passive filter networks for receivers. This method has the advantage of not introducing distortion components. Moreover, the number of receivers that may be added to the line is limited only by the loss in signal strength introduced by each new receiver connected. Circuits have been developed which allow receivers to present a high impedance to the transmission line from the point of resonance, so that several receivers tuned to different frequencies but connected to a common transmission line will not seriously load one another. These circuits, however, are limited in design by maximum attainable Q

⁴NEL Report No. 147 (RESTRICTED), *Limits Imposed by Noise upon Multiplexed Receivers in the 15-Kc to 27-Mc Range* (Final), by J. H. Raleigh, (in press).

⁵NEL Report No. 94 (RESTRICTED), *Evaluation and Comparison of the AIL and the Navy Model RXA Antenna Multicoupler Units* (Final), by J. H. Raleigh, 30 December 1948.

⁶NEL Report No. 142 (RESTRICTED), *Evaluation of Signal Corp Model CU-52XC-1/URR Antenna Coupling Unit (and Comparison with Navy Model RXA Multicoupler Unit)* (Final), by J. H. Raleigh, 24 October 1949.

of circuit elements, and by the impracticability of placing all receivers at the termination of the transmission line.

An alternative to receiver multiplexing is being tackled by the University of California's Radio Research Laboratory, working in close cooperation with NEL. This is the use of a separate, short, tunable, monopole antenna for each receiver aboard ship. This device is shown in Figure 4. The scheme affords excellent receiver isolation. The antennas can be mounted flush with the deck and, because of the efficient energy transfer, can feed receivers over long transmission lines. Space and installation needs, therefore, may easily be solved. One objection to the system, however, lies in the small effective height (perhaps one foot) of the antennas, which limits signal pickup. A second and perhaps more important deterrent is that a complicated servo system is needed to tune each antenna to resonance in synchronism with the receiver.

If the very short tunable monopole type of antenna is not used on the CLC-1, two types of long untuned receiving antennas will probably be employed. These will be the conventional long-wire and whip types, already standard equipment on many ships.

Conclusion

The CLC-1 plans afford the unusual opportunity of treating shipboard antennas as integral to basic ship design, instead of appendages. Thus, optimum antenna sites can be selected. The multiplexing technique applied to transmitters promises to divide the number of antennas required by at least a factor of four. For reception, a number of likely methods of raising signal-to-noise ratios are currently under investigation. The final solution has not been completely determined, but it has been proved that shipboard communications facilities can be greatly improved over present practice.

The electronics art is an ever-changing one and it is such continuing work as has gone into the CLC-1 systems design that will keep the Navy abreast of communications development. It is the ability to integrate all forms of communication and intelligence-gathering equipments into a workable system that has made it possible to design such a ship as the CLC-1.

ERROR IN NAVSHIPS 900,155

The CIC Team Training Center, San Diego, Calif. reports an error in the "Electronic Test Equipment Handbook, Commercial Designations." NavShips 900,155. On Page 31 of Volume I, the first equipment designation should read 202NX rather than 202.

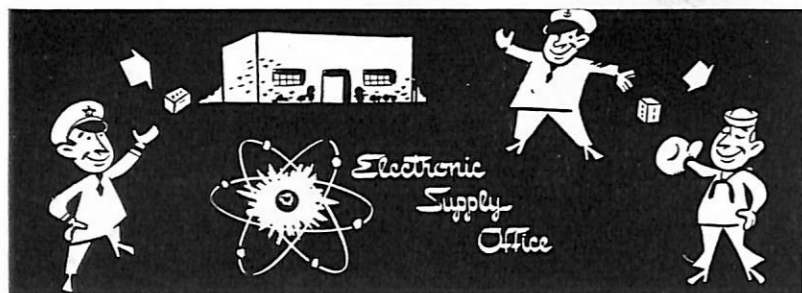

PACKING OF CRYSTAL RECTIFIERS

This office has become aware that silicon and germanium crystal diodes are being received in a defective condition due to faulty packing.

Packing specifications require each crystal to be completely enclosed in an approved, non-magnetic, electrical conducting shielding and packed in a telescoep-style chip-board set-up box. They must also be centrally suspended within the box or wrapped in shock absorbent material in a manner that affords full protection from shock. Deviations from this method of packing generally result in damage to the item.

All ships or stations receiving crystal rectifiers improperly packed should notify the Electronic Supply Office, Great Lakes, Illinois, immediately following their receipt.

BREAKDOWN PROGRAM RECAPITULATED

The Breakdown Program has resulted in significant savings to the Navy since its inception. This is emphasized by a recapitulation of the cost and value of this project, as of 31 December 1949.

By means of the Breakdown Program, spare parts boxes are opened and each item therein removed, segregated, identified, and tagged with an appropriate stock number. The items are then placed in bins or on shelves and are reflected in quarterly inventories, thus being made available for issue by the stocking activity or for diversion to another activity.

The cost of this recovery averaged only four cents a piece, whereas the average estimated value of each piece was 98 cents, or nearly 25 times the recovery cost.

The value of the material processed for stock from 1 September 1948 to the present is estimated at \$24,660,-313.00 or approximately \$6.50 per spare parts box. Pieces processed for stock total 25,163,585—an average monthly production of 1,572,724.

As of 31 December, 156,175 boxes had been broken down and an estimated 83,000 boxes remained on hand. The major activities participating in this Breakdown

Program are SSD, NSC, Oakland and NSD, Bayonne. The program also was carried out on a lesser scale at several shipyards and stations.

BUSHIPS CONTROLLED COMPONENTS

This office assumed certain responsibilities, as of 21 May 1950, in connection with the inventory control, distribution and redistribution of BuShips controlled components and parts. In addition to a revision of the reporting procedures, which eliminated NavShips 2605 as a reporting media, a modification in the procedures covering the preparation and issue of shipment orders became effective.

Previous to 21 May 1950 the Bureau would, upon approving requests for BuShips controlled items and components, issue necessary shipping orders and instructions. The modified procedure provides for the Bureau to inform ESO of all approved requests for material and in turn the necessary shipment orders and instructions are prepared by this office.

Shipment orders issued by this activity will, in addition to other information, bear the stock number applicable to the material. This in itself represents a departure from the previous method of identifying material solely by a Navy Type Number. Although Navy Type Numbers, frequently referred to as nameplate nomenclature, will continue to be used for many other purposes, it will be necessary to use stock numbers for inventory and accounting transactions. Navy Type Number to stock number cross-reference data has been forwarded to certain activities and will, at an early date, be given wider distribution.

FIELD CHANGE KITS

When a part included in a field change kit fails, that particular part should be ordered by stock number. A duplicate field change kit should not be ordered as such a method of replenishment is extremely wasteful.

When a certain field change kit is procured, the quantity required is determined by the number of equipments in the system, and only one kit is obtained for each equipment. Repairs are to be effected by requisitioning only those parts required.

E.S.O.

MONTHLY COLUMN

RADIAC PARTS STATUS

While radiac equipments and components are under the control of the Bureau of Ships, parts peculiar, although initially purchased along with the equipments and components, are under the inventory control of the Electronic Supply Office, which also purchases and controls the parts common.

To date common parts for the IM-3/PD, AN/PDR-2; IM-7/PD, IM-4/PD, AN/PDR-5, IM-5/PD, AN/PDR-8, AN/PDR-8B, AN/PDR-8C, AN/PDR-8D, and AN/PDR-4 are under procurement at ESO. These parts will be distributed to the primary distribution points and stock maintained in accordance with the Quarterly Stock Status Report.

RUGGEDIZED TUBES

Ruggedized tubes, which are usually designated by the letter "W" following the tube type number, were originally developed by the receiving tube manufacturing industry under contract with the Bureau of Ships. As a result of this developmental work, many of these tubes are now covered by firm specifications and are available to both military and civilian consumers.

The Electronic Supply Office is purchasing ruggedized in lieu of non-ruggedized tubes to fill requirements for those applications where the two types are mechanically and electrically interchangeable.

The price of a ruggedized tube is considerably higher than that of the conventional type since special tooling is required and this cost is added to the price of the tube. However, the ruggedized tube's longer life and ability to withstand high impact shock and prolonged vibration more than offset the increase in price.

REPROVISIONING

The program for reprovisioning the various Electronic Equipments used throughout the Navy and originally procured by BuShips is well underway. Each equipment is researched separately and "Parts Peculiar" lists developed. The total number of equipments installed in the active and inactive fleet is considered when a stock level to be maintained is determined for the part peculiar item. Such levels are checked against current Elec-

tronic Supply System inventories to insure that the recommended stock level is on hand or due in the system.

OBTAINING STOCK NUMBERS FOR CONTRACTORS

The specification 16E6 (Ships) entitled "Electronic Spare Parts Requirements" is being referenced in contracts for the procurement of new equipments. This specification reflects the new Spare Parts Program under which parts peculiar are provided on equipment contracts and parts common obtained by the Electronic Supply Office under separate procurements.

The old method of procurement of Spares on a straight percentage basis for all parts (common and Peculiar) was the best that could be provided at the time, but occupied much valuable space aboard ship. The 16E6 specification permits procurement of parts peculiar on the basis of life expectancy. Conforming to the new Spare Parts Allowance Program, it takes advantage of the interchangeability of all parts common items.

The new specification also requires that the Maintenance Parts Lists contain JANAP 109 or MBCA descriptions with Standard Navy Stock Numbers for each item (common and peculiar). These parts lists will be a great aid for requisitioning replacement parts for equipments.

To meet the above-mentioned requirements, the contractor is asked to prepare for each maintenance item on the parts list, seven legible copies of a tabular description on NavSandA Form 217 in accordance with the requirements of JANAP 109 or MBCA Description Patterns. These descriptions, plus five dimensional fabrication drawings for each item, are to be forwarded to ESO, where they will be assignment checked for ESO or Standard Navy Stock Number counterparts. If an SNSN is not available, they will be sent to the Navy Material Catalog Office for new assignments of Standard Navy Stock Numbers. If an ESO Stock Number is available, it will be noted, forwarded to the Navy Material Catalog Office, and, upon return, the ESO Stock Number will be transferred to the Standard Navy Stock Number.

In the past, many Spare Parts were furnished in equipments or stock spares that were not identical to the original part in the equipment and did not meet the description as shown in the equipment instruction book. Such substitutes obviously caused considerable confusion and delay in requisitioning, identification and issuing replacement parts. Under the 16E6 specification, if the contractor is unable to supply the item exactly as originally described, he submits new descriptions and drawings, and new stock numbers are furnished.

FALSE ECHOES

Under certain peculiar conditions, any radar will produce signals which are difficult to interpret. The ease and speed with which these can be interpreted will depend largely upon a man's past experience and/or understanding of the problems involved. The following discussion is intended to supplement this understanding.

It is quite possible to receive radar signals which do not behave in the normal manner. The signal may be lacy and may be difficult to isolate or take a bearing on. These signals may give every indication that there is something wrong within the equipment. No amount of adjustment within the equipment will appreciably alter the type of signals being received except as follows. If the sensitivity of the equipment is improved, these peculiar signals may become more pronounced. Likewise, if the equipment is thrown out of adjustment,

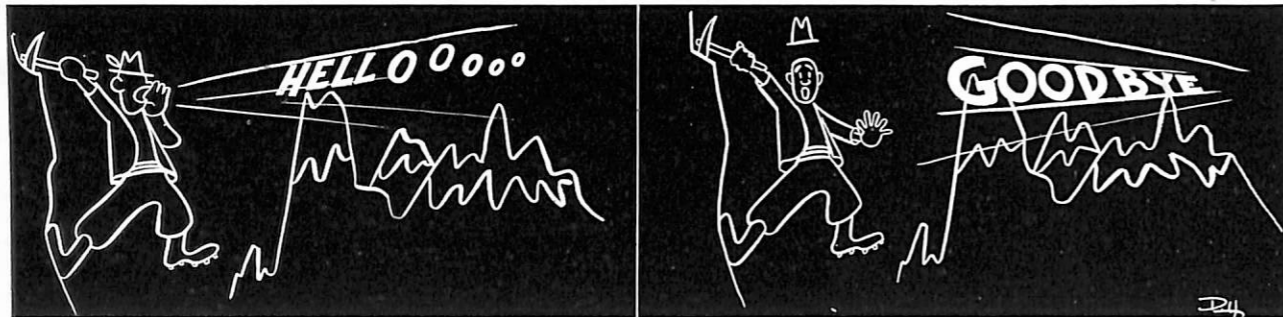

the signals may decrease or disappear. Such signals will probably be evident only when a ship is operating in clear water at an appreciable distance from landfall and when the equipment is in top-notch condition.

An analysis of the situation will indicate that there is no target visible within the range of the first sweep on the indicator, which may be some fifty thousand yards or so. The nearest target of any size is beyond this distance and is producing echoes which appear on the second or third sweep. The instantaneous timing between successive sweeps will usually not be uniform enough to produce solid echo signals. The signals will be lacy and not too well defined.

There are several suggested means for determining when such signals are outside of the first sweep range. If the sensitivity of the receiver is decreased slightly these signals should disappear. Second, the signals should disappear if the transmitter power is reduced by reducing the input voltage in the modulator. Third, the signals should "walk" if the system rep. rate is changed. Fourth, such signals should occur only when the antenna is at approximately zero elevation and should disappear if the antenna is raised or depressed slightly from the angle of maximum return. Also when the director is trained away from the second or third sweep target it

should disappear, showing that it is a received echo—not a fault of the radar.

It is quite possible to observe beautiful strong signals on the second or third sweep from cloud formations, providing the cloud contains a high percentage of condensed moisture. In this case the antenna elevation angle might not be zero. Atmospheric "channels" can produce echoes from distant targets at elevation angles other than zero. The same tests as indicated above can be applied to determine when these signals are outside of the first sweep range.

Targets which occur at the time of second or third sweep may appear superimposed upon target occurring within the first sweep interval. The first sweep targets will be clear and distinct while the second sweep targets will usually be lacy and indistinct. Likewise first sweep

targets usually are strong enough to obscure second sweep targets. If there are no targets within the first sweep interval, only the second sweep targets will appear. Signals observed on a Class A sweep will be fairly easy to identify and classify as either first or second sweep signals. Signals presented on a Class B or PPI picture may not be so easily identified. Minor lobe signals added to these second sweep signals can frequently present a very confusing problem.

When unusual signals are received, try analyzing the conditions before tearing into the equipment. Check with other radars of the same type on board, or with those on adjacent ships and see if they are receiving the same kind of signals. It might be possible to save considerable time and effort if you do this first.

NOTE:—If you get these hard-to-understand echoes on, say, a Mark 25, it may not do you any good to look for the same thing on a search radar because of the difference of location, power, antenna, rep rate, sweep length, and other things. If two or three Mark 25's do the same thing, it is pretty good evidence that all three are OK, and that there is a screwy atmospheric condition. Incidentally, it has been noted that atmospheric conditions in the Mediterranean give some pretty long ranges, so when in that area you might keep that in mind.—*W. E. Newsletter*

Electron

IS YOUR MIRROR

it reflects your thoughts
and experiences
..it reflects the thoughts and
achievements of others...
dont let it be a half-mirror
...keep the image
complete by letting others
see your ideas, problems
and achievements

SEND THEM TO THE EDITOR
BUSHIPS ELECTRON



ELECTRONICS . .

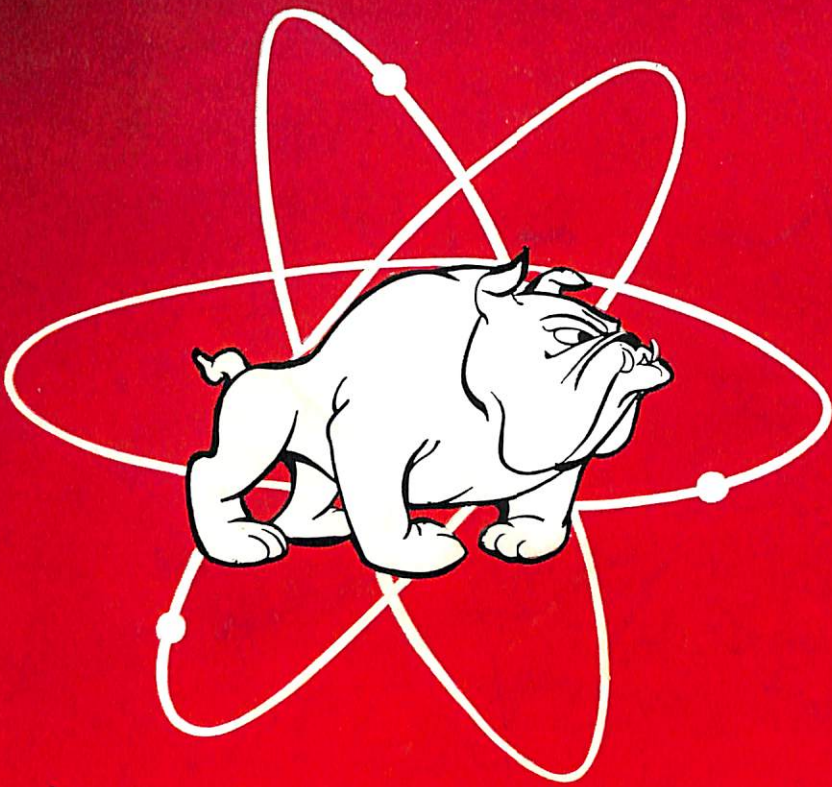

. . WATCHDOG

. . . of the FLEET !

Price