

**RESTRICTED**

**OCTOBER 1948**

**BUSHIPS**

*Seafarer*

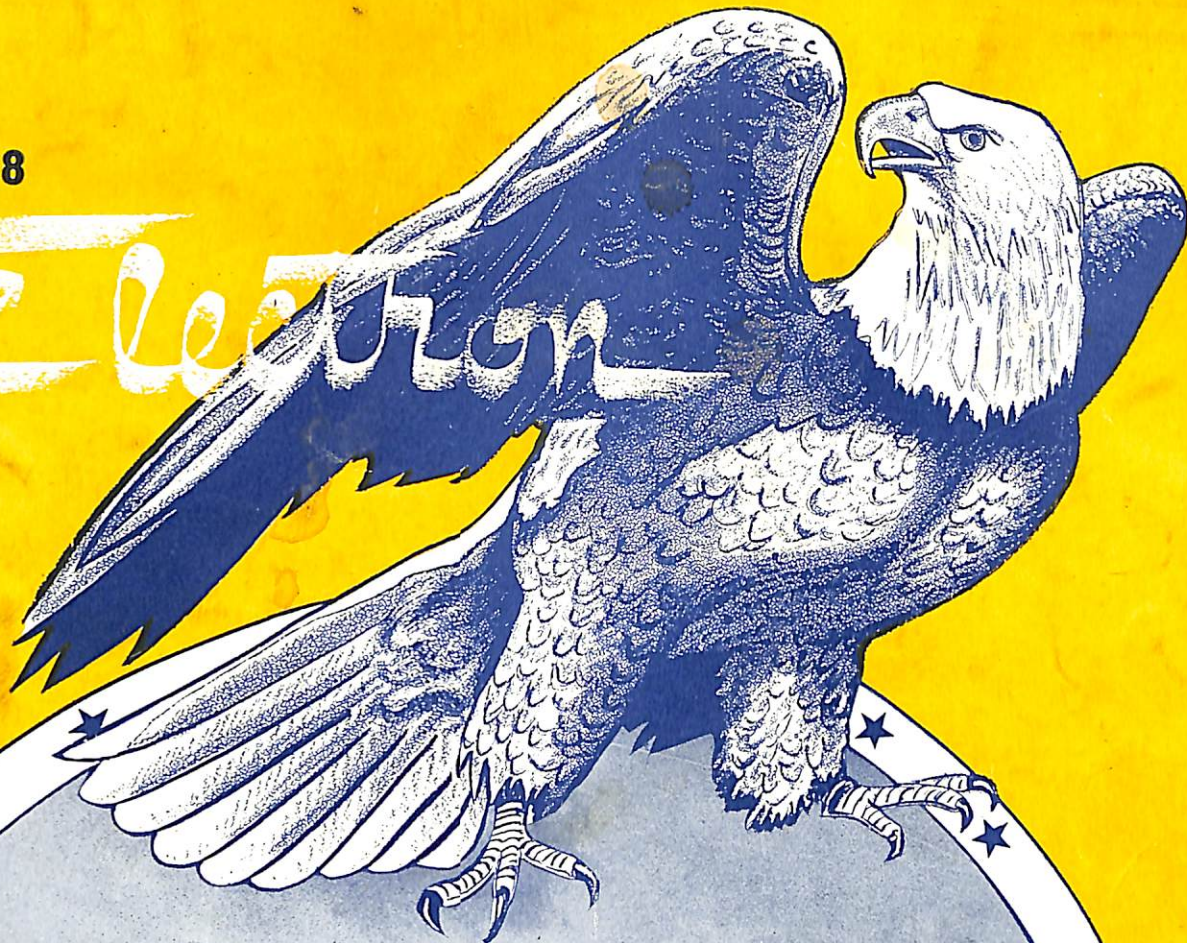

**NavShips 900,100**



*The Norfolk Naval Shipyard*

BUSHIPS

# Electron

A MONTHLY MAGAZINE FOR ELECTRONICS TECHNICIANS

OCTOBER, 1948

VOLUME 4

NUMBER 4

<i>Rear Admiral David Henderson Clark, U. S. Navy</i> .....	2
<i>Highlights in the Years of the Norfolk Naval Shipyard</i> .....	4
<i>Historical Sketch of the Electronics Office</i> .....	5
<i>The Electronics Officer and Commanding Officer of NAVCOMSTA</i> .....	7
<i>The Electronics Shop, Norfolk Naval Shipyard</i> .....	9
<i>Fleet Training Center</i> .....	11
<i>The 120-Inch Sonar Dome and Retracting Gear</i> .....	13
<i>Factors Affecting U-H-F Performance</i> .....	15
<i>Dynamic Frequency-Shift Spread Measurements</i> .....	17
<i>Mobile Communication Equipment</i> .....	19
<i>Maintenance of Radio Aids to Air Navigation</i> .....	23
<i>New Control Tower at Naval Air Station, Norfolk</i> .....	25
<i>Radar Antenna Stabilization</i> .....	27
<i>R.F. Goes Underground</i> .....	32
<i>G.C.A. Box Score</i> .....	34
<i>Naval Railroad Communication in Fifth Naval District</i> .....	36
<i>Basic Physics, Part 13</i> .....	38
<i>Lightweight Model 15 Teletypewriter</i> .....	49

**DISTRIBUTION:** BUSHIPS ELECTRON is sent to all activities concerned with the installation, operation, maintenance, and supply of electronic equipment. The quantity provided any activity is intended to permit convenient distribution—it is not intended to supply each reader with a personal copy. To this end, it is urged that new issues be passed along quickly. Copies may then be filed in a convenient location where interested personnel can read them more carefully. If the quantity supplied is not correct (either too few or too many) please advise the Bureau promptly.

**CONTRIBUTIONS:** Contributions to this magazine are always welcome. All material should be addressed to

The Editor, BuShips Electron  
Bureau of Ships (Code 993-b)  
Navy Department  
Washington 25, D. C.

and forwarded via the commanding officer. Whenever possible, articles should be accompanied by appropriate sketches, diagrams, or photographs.

**CONFIDENTIAL:** Certain issues of BUSHIPS ELECTRON are classified confidential in order that information on all types of equipment may be included. The material published in any one issue may or may not be classified, however. Each page of the magazine is marked to show the classification of the material printed on that page. The issue is assigned the highest classification of the material included. Classified material should be shown only to concerned personnel as provided in U. S. Navy Regulations. Don't forget, this includes enlisted personnel!

BUSHIPS ELECTRON contains information affecting the national defense of the United States within the meaning of the Espionage Act (U.S.C. 50; 31, 32) as amended.

BUREAU OF SHIPS

NAVY DEPARTMENT

RESTRICTED



Rear Admiral David Henderson Clark, U. S. N.  
Commander, Norfolk Naval Shipyard

## DAVID HENDERSON CLARK REAR ADMIRAL, U. S. NAVY

Rear Admiral Clark was born February 25, 1899 at Henderson, Kentucky. He was admitted to the Naval Academy in 1915. After graduation in June, 1918 he served during World War I as Gunnery Officer in the USS TERRY engaged in anti-submarine operations out of Queenstown, Ireland.

From 1919 until 1923 Rear Admiral Clark served in various capacities in destroyers and the USS WYOMING. In 1923 he was selected for post graduate training in Electrical Engineering at the Naval Academy and Columbia University. Following his graduate training, he performed engineering and command duties afloat and ashore until 1933, when he was assigned duty in the Fire Control Section of the Bureau of Engineering.

In 1935 Rear Admiral Clark was designated for "engineering duty only." Following a tour of duty at the Post Graduate School in charge of Naval and Aeronautical Engineering Training, he returned to the Bureau of Engineering in 1938 where he served as personnel officer. During this period he was engaged in working out the manifold problems in connection with the consolidation of the Bureaus of Engineering and Construction and Repair into the present Bureau of Ships.

In June of 1941 Rear Admiral Clark became Fleet Engineer on the staff of the Commander in Chief, Pacific. He was active in forming the Fleet Maintenance Office and served as Assistant Fleet Maintenance Officer until August, 1943. For his fleet service in World War II he was awarded the Legion of Merit for the great improvement in the material readiness of the fleet.

From September 1943, Rear Admiral Clark served for the balance of the war as Planning Officer at the Navy Yard, Boston. For this service he received a letter of commendation from the Secretary of the Navy.

In February 1946 Rear Admiral Clark became Director of the Naval Engineering Experiment Station, Annapolis, Maryland, and in March 1947 reported to the Norfolk Naval Shipyard, Portsmouth, Virginia, as Commander.

Rear Admiral Clark's keen insight and understanding of technical problems has greatly facilitated the integration of Electronics into the work of the shipyard.

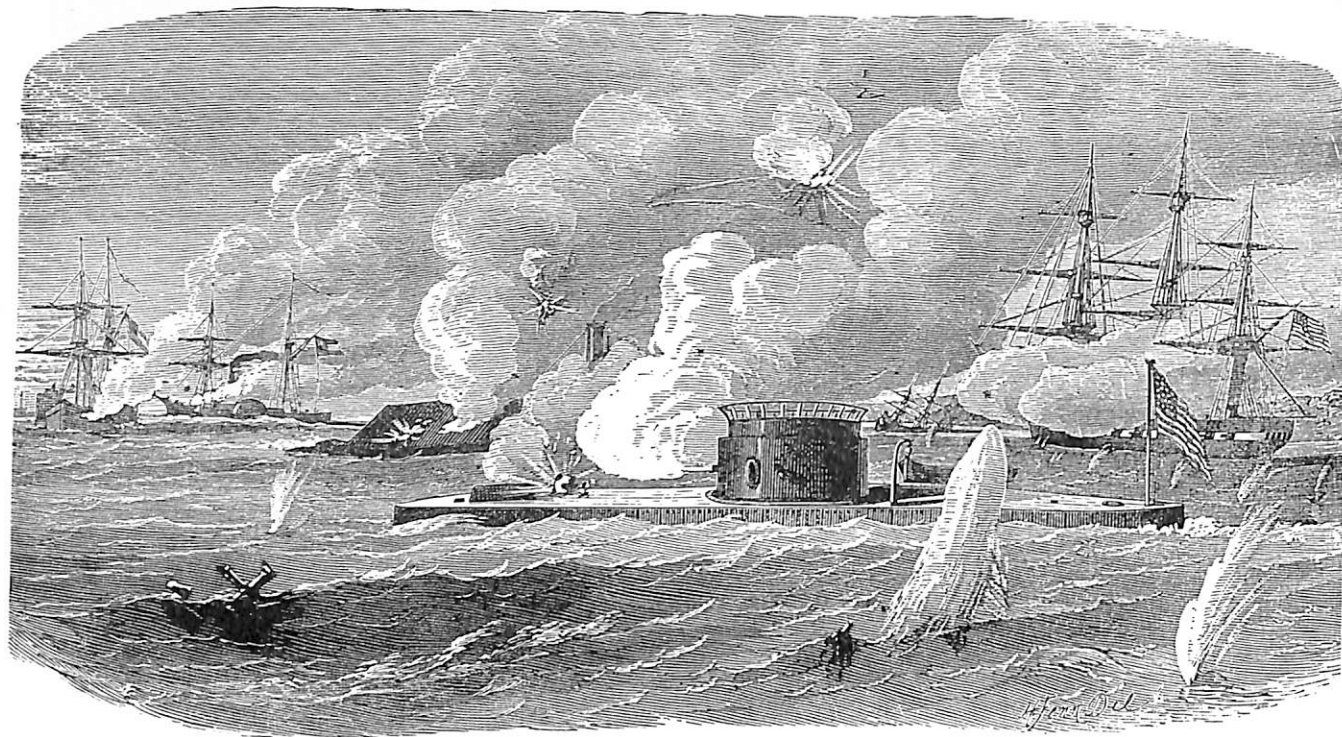

## HIGHLIGHTS IN THE YEARS OF THE NORFOLK NAVAL SHIPYARD

The Norfolk Naval Shipyard, originally called the Gosport Navy Yard, was established as a marine repair yard by the British just prior to the Revolutionary War. At the outbreak of the conflict it was confiscated by the Colony of Virginia and used by the Virginia Navy and vessels of the Colonial Congress as well.

In 1801 the Federal Government bought the property, amounting to about 16 acres, from Virginia for \$12,000 as part of its compliance with an "Act to Provide a Naval Armament" passed by Congress in 1794.

Many interesting incidents of Naval History are associated with the Norfolk Naval Shipyard. A few of them are given here:

1799—Famous U.S.S. *Chesapeake* launched.

1801—Commodore Richard Dale's squadron fitted out to go to work on the Barbary Pirates.

1806—Captain Stephen Decatur ordered to yard. This famous officer superintended building of gunboats until 1811.

1810—Commodore Samuel Barron became first Commandant.

1834—First drydock completed. *Delaware*, launched in 1820, was first U.S. ship to enter a drydock belonging to U.S.

1861—Yard destroyed and ships scuttled to prevent use by advancing Confederate forces. One of vessels scuttled was steam frigate *Merrimac*, which was later raised and rebuilt by Confederates and re-named *C.S.S. Virginia*.

1862—Ironclad *Merrimac* fought *Monitor* in Hampton Roads, a stone's throw from Norfolk Navy Yard.

1862—Confederates destroyed yard and abandoned remains to Federal forces. *Merrimac* blown up by retreating Confederates.

In 1917 began the construction of the modern Norfolk Naval Shipyard. New and modern buildings were raised; a power plant was built; shops and storage facilities were established; additional dry docks were constructed. Countless improvements were made during the following 30 years, until today it is one of the most up-to-date repair, shipbuilding and manufacturing plants in the United States; today it has facilities for building, docking and repairing vessels of all classes, from the subchaser and fishing smack to the most modern of battleships and ocean liners.

The Norfolk Naval Shipyard has the unusual distinction of having been under five different flags: British, Virginia Colonial, State of Virginia, Confederate States, and United States.



## HISTORICAL SKETCH OF THE ELECTRONICS OFFICE

By H. G. GWALTNEY

Navy electronics made its first appearance in the Norfolk Naval Shipyard about 1903. During that year the shipyard made its first shipboard wireless installation. Details concerning this installation are lost in official records, but it can be assumed that it was the usual spark and detector set based on the invention of Marconi. In the same year a station was established in Building 51 of the shipyard which became the great grandfather, many times removed, of the present radio station at the Naval Base, Norfolk, Virginia. Installation and repairs on all wireless equipment were accomplished by the Electrical Shop.

No need for expert technical advice was demonstrated until the entry of the United States into World War I. Records show that one of the first full-time specialists of the shipyard was an expert radio aide,

Mr. H. E. Halberg. Mr. Halberg, and others who came later, were involved in the design and development of special equipment. By that time the introduction of the DeForest Audion had made wireless installation more complicated. There was no regularly appointed radio officer even during the war years. Electronics work was administered by the shipyard engineering officer.

World War I developed the scope of wireless, or electronics, to where it became necessary to provide an organization to administer and perform electronics engineering. In 1919 Lt. Comdr. C. Ridgely became the first regularly appointed Radio Material Officer.

The first appointed Radio Material Officer was succeeded in chronological order by the following officers:

1923 Lt. Comdr. E. H. Primlan

1924 Lt. R. W. Hungerford

1925 Lt. C. B. Arney

*continued on next page*

### ★ ★ ★ ★ ★ THE ELECTRONICS OFFICER ★ ★ ★ ★ ★

Commander Myers enlisted in the Navy in January, 1927, and was appointed to the U.S. Naval Academy in June 1928. He was graduated in June 1932, and subsequently advanced to the rank of Commander.

Following his graduation in 1932, Commander Myers was assigned to the U.S.S. *Arizona* (BB39) and served in that battleship until April 1934, at which time he started duty in destroyers. He served successfully in the *Noa* and the *Blakely*. This was followed by one year of duty in communication on the Staff of the Commander Scouting Force, U.S. Fleet, after which he was assigned to the *Drayton*. In June 1938 he reported to the Postgraduate School and received instruction at the U.S. Naval Academy and Harvard University in Radio Engineering. He received the degree of Master of Communication Engineering from Harvard University in 1941.

In June 1941, following his graduation from the Post Graduate school, he was assigned to the Underwater Sound experimental ship *Semmes* as Executive and Technical Officer. During this period the mission of the ship included much test and new development work in the accelerated anti-submarine and Radar programs.

In October 1942 he was assigned to the West Coast Sound Training Squadron at San Diego where he was instrumental in establishing the curriculum for training sonar operators and maintenance men for undersea warfare.

In April of 1944, Commander Myers reported for duty in the Bureau of Ships, where he served as the head of the Sonar Design Branch. During this period he was responsible for the development of new types of sonar equipment for surface and undersea craft.

In April of 1946 he was ordered to the Office of the Chief of Naval Operations where he served in the coordination of the Navy's development program in the guidance and control of guided missiles.

After being detached from duty in the Office of the Chief of Naval Operations, he reported for duty as Electronics Officer, Norfolk Naval Shipyard in August 1947, relieving Captain W. L. Pryor, Jr.



Commander Jacob Christian Myers

Continued from page 5

- 1927 Lt. A. Prastka
- 1930 Lt. Eddie Spenhler
- 1932 Lt. Comdr. W. A. Tattersall
- 1934 Lt. "Tiny" Schultz
- 1936 Lt. Paul F. Dugan
- 1938 Lt. "Red" Armstrong
- 1940 Lt. Comdr. W. B. Bailey
- 1942 Capt. H. W. Kitchen
- 1946 Capt. W. L. Pryor, Jr.
- 1947 Comdr. J. C. Myers

The members on the staff of the Radio Material Officer of 1919 numbered four; one expert radio aide and three radio inspectors. The size of the staff of the Radio Material Office changed little between World War I and 1929. In 1930 Mr. Abram A. Cory, present Chief Civilian Assistant to the Electronics Officer, joined the staff. In 1940 the nucleus of the present civilian staff

was established. By the end of 1940 the staff totaled ten inspectors and engineers and the assigned laboratory area was approximately nine hundred square feet.

During World War II the vast expansion in electronics necessitated an increase in the organization from the 1940 level to a total of 201 engineering officers, contract engineers, and technical and clerical personnel. Laboratory and office space increased from nine hundred to eleven thousand square feet.

The aftermath of World War II has revealed that naval electronics envelops both the most important offensive and defensive weapons available to the U.S. Navy.

The Norfolk Naval Shipyard, with new electronics facilities including shop, office and laboratory area totaling about sixty thousand square feet, looks forward to serving the Navy in any eventuality.

# THE E.O. AND THE C.O. OF NAVCOMSTA



The Electronics Officer, Comdr. J. C. Myers, confers with the Commanding Officer of NavComSta, Capt. C. A. Dillavou, on District Plans for the improvement of Communications.

## ★ ★ ★ ★ ★ CHIEF CIVILIAN ASSISTANT ★ ★ ★ ★ ★

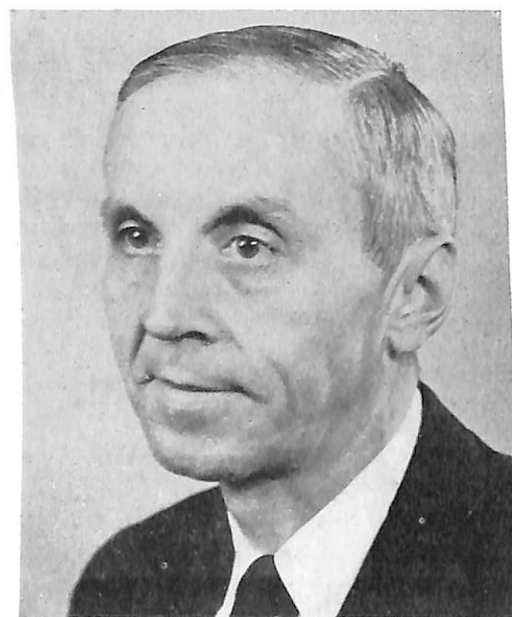

Mr. Abram A. Cory

Mr. Abram A. Cory received his B.S. and M.S. degrees in Electrical Engineering from the University of North Carolina in 1926 and 1928.

He started with the Radio Material Office, Norfolk Navy Yard, in 1930 as Assistant Radio Engineer and has had uninterrupted service since that time. Mr. Cory became interested about 1938 in developing a means of controlling shipboard radio direction finder deviations at intermediate frequencies and originated a "crossed loop" method of accomplishing this. Although successful, only a few shipboard installations were made due to the adoption of the Bellini-Tosi type loop by the Navy. However, the information obtained from these deviation investigations suggested a method of accurately locating planes of low deviation aboard ship. Direction finding loop antennas for low and intermediate frequency equipments may now be installed without resorting to the usual corrector loops which result in losses of sensitivity.

During many of the depression years, when the Navy was at its lowest strength, Mr. Cory was the sole radio engineer of the radio organization at the Norfolk Naval Shipyard. With the expansion of the Navy immediately preceding World War II, he started to assemble the nucleus of the present Electronics Office staff. As Chief Civilian Assistant of the Electronics Officer he is responsible for coordinating and reviewing the priorities of electronic work performed by the shipyard and supervising and coordinating the work of the civilian Electronics Office staff.



## ★ ★ ★ ★ ★ THE AUTHOR ★ ★ ★ ★ ★

Howell G. Gwaltney was born in Winston Salem, N.C. on April 23, 1914. He attended grammar and high schools in Winston Salem and the Oak Ridge Military Institute at Oak Ridge, N.C., graduating from Oak Ridge in 1935. He attended N.C. State College, Raleigh, N.C., receiving a B.S. degree in electrical engineering in June 1938.

Mr. Gwaltney worked two years in power engineering prior to entering the shipyard in 1940 as a Radio Inspector. He is engineer-in-charge of the Radio Group, Ship Section, of the Electronics Office.

The district Commanding Officer of Naval Communication Stations, as a direct representative of the District Commandant, exercises management control of shore electronics activities. In this capacity he acts as field representative of the Chief of Naval Operations. The Electronics Officer, as a direct representative of the Commander of the Shipyard, and vested with "Deputy Commander" status, exercises technical control over all shore electronics activities under the cognizance of the Bureau of Ships. Together they are responsible for the smooth and efficient operation of the shore electronics network, including communications, electronic aids to air navigation, harbor detection, and the myriad other functions that employ electronic techniques.

The C.O. of NavComSta is responsible for the operation, routine maintenance and repairs (not requiring alterations) to electronics equipment within the capacity of station forces. The E.O. is responsible for installations, alterations, repairs, and maintenance beyond the capacity of station forces. The borderline between these two conditions is constantly shifting with the availability of station forces or technical manpower operating under the supervision of the E.O.

The former is responsible for determining and stating the functional requirements of electronics facilities to carry out the mission of the district. The latter in

turn translates these into types of equipment, power, and space requirements and site recommendations. He then initiates projects to insure proper installation and maintenance.

Requests for new station allowances are scanned by both officials. The one makes recommendations based on the operational needs; the other makes technical recommendations. Decision on such requests is an important function that requires a great deal of collaboration on the part of both officers and station personnel as well, in order to determine that the allowance requested will in fact satisfy the operational needs and utilize the best techniques available.

The E.O., acting in the capacity of BuShips field representative for the release of BuShips-controlled equipment, has the further responsibility to process requests for electronics material in order to insure an adequate and timely supply to meet the operational needs. This function is often extended beyond the basic supply of major equipments to components, accessories, bolts and nuts.

In order to carry out these overlapping responsibilities, the closest cooperation between the C.O. of NavComSta and the E.O. is required. They are jointly responsible for the operation and maintenance in an efficient and economical manner.

At outlying stations many of the responsibilities of these offices are delegated to the Communication Officer and the Electronics Officer at the station. Often these responsibilities rest on a single person—the Communication Officer. To help these officers carry out their duties, the activities are inspected at regular intervals by parties consisting of representatives of both the E.O. and the C.O. of NavComSta. To keep these outlying stations in operation and maintained, funds are required. The shipyard suballots a portion of its M.B.S. allotment to pay for the burden of routine maintenance. Similarly, a portion of the funds granted to the District Commandant for operation are suballotted to the activity concerned. In these cases financial reports are made to the shipyard or to the District Commandant as the case may be. The use of these funds requires a great amount of coordination on the part of the C.O. of NavComSta, the E.O., and the station Communication Officer, not only to insure that the funds are used properly but to insure that they are used for the most efficient operation of the activity.

In the Fifth Naval District much of the success of operations utilizing electronics has been due to the frequent conferences, visits, and general cooperation on the part of all concerned.



*Mr. O. L. Mullican*

O. L. Mullican was born in White Sulphur Springs, West Virginia on July 17, 1903. About 1906 Mr. Mullican's family moved to Norfolk, Virginia where he attended elementary and high schools. He served his apprenticeship with the Osborn Electric Company of Norfolk and worked with various electrical contractors in that city and in Washington, D.C. He attended University of Virginia extension courses in electrical engineering. Mr. Mullican entered the shipyard in 1926 as an electrician and progressed through the various electrician rates to Chief Quartermaster, Electrician in 1942 and to Foreman in 1944. He was appointed Master Electrician in 1946.



*Teletype Facility, manned by Machine Shop personnel.*



*Tower Facility. Radio and Radar antennas installed here allow equipment testing under actual working conditions.*

## THE

### MASTER ELECTRICIAN

## ELECTRONICS SHOP

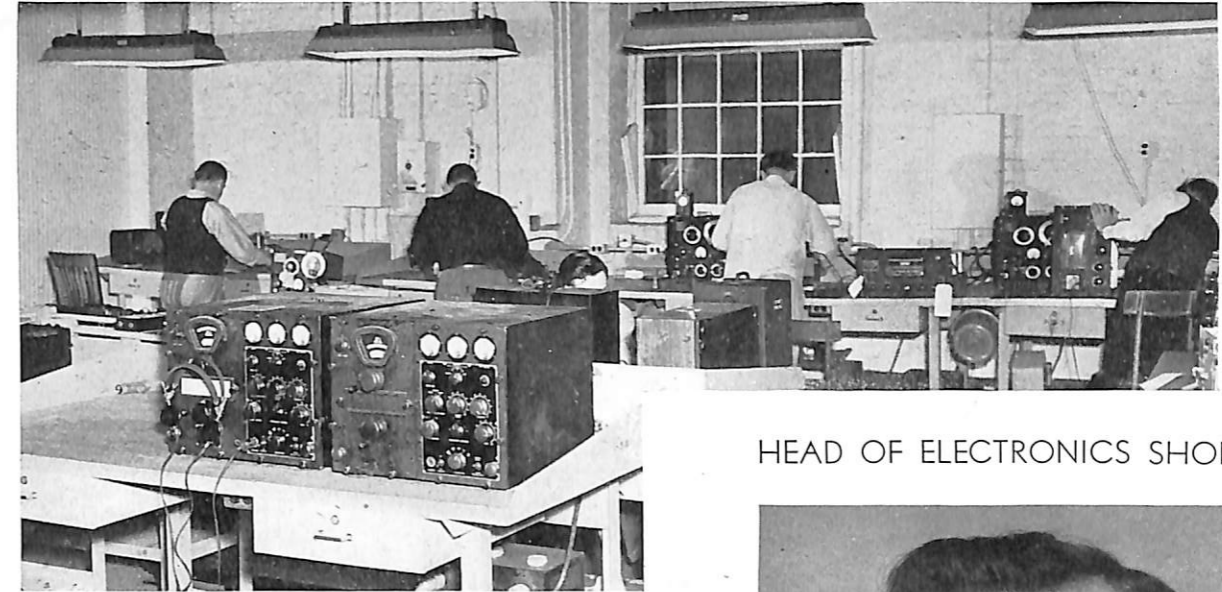

*Repair Section. Regular Overhaul Ships equipment being serviced.*

### HEAD OF ELECTRONICS SHOP



*William T. Bunting*

## NORFOLK NAVAL SHIPYARD



*Shipping Section. Reconditioned equipment being packed for store.*

William T. Bunting was born in Portsmouth, Virginia on October 18, 1912. He entered the Norfolk Naval Shipyard as an apprentice electrician in 1930 and graduated to journeyman in 1934. Mr. Bunting worked as journeyman electrician in the electrical shop, and attended University of Virginia extension courses in electrical and electronics subjects until 1937. He then transferred from the Electrical Shop to the Shipyard Progress Section and worked there as a Progressman until 1940. He again transferred to the Electrical Shop and served as Chief Quartermaster Electrician, new construction, during the war years, supervising electrical and electronics work in *Essex* class carriers.

Mr. Bunting is now Foreman, Electronics in charge of the Electronics Shop, which was established on 1 April, 1948 under the Master Electrician.



One corner of the Radio Transmitter Test Section of the Electronics Shop.



View of a portion of the Electronics Shop. Production line reconditioning of "Stock," electronics equipment is accomplished here.

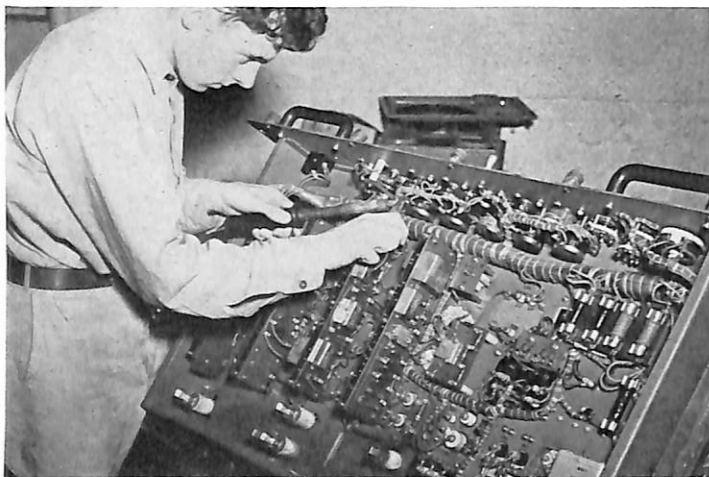

Electronics Shop electrician modifying electronics equipment.

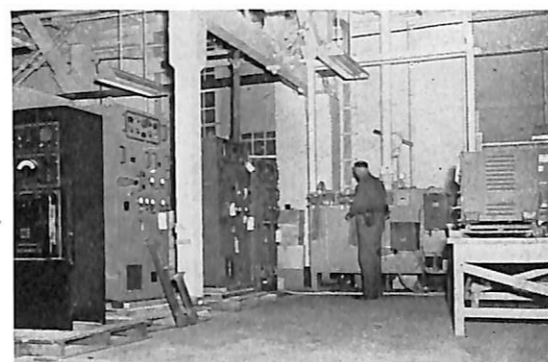

Radar equipment undergoing test by the Electronics Shop prior to installation.



Machine Shop personnel man the Mechanical Section of the Electronics Shop.

## FLEET TRAINING CENTER

By LT. B. M. KASSELL, USN

The Fleet Training Center, Naval Base, Norfolk, Va., under the command of Commander F. J. Johnson, USN, is one of the many activities in the Fifth Naval District dependent upon the Electronics Office in the Norfolk Naval Shipyard for logistics support.

The Fleet Training Center comprises the following activities:

- Combat Information Center School
- Countermeasures (RAD and COM) Schools
- Radio Operators School
- Anti-Submarine Warfare School
- Damage Control School
- Night Convoy Escort Trainer
- Telephone Talkers School
- Lookout and Recognition School
- Synthetic Gunnery Trainer
- Ammunition Handling School
- Fire Fighter's School
- Area Radio Drill Circuit

These activities are charged with the training of personnel afloat in the various phases of shipboard routine commensurate with individual ratings.

In order to accomplish this mission, the various schools are fitted out with mock-ups, trainers, training aids and operative equipments, the greater majority of which are electronic devices.

The Bureau of Ships and the Special Devices Section of the Office of Naval Research design and develop the various trainers and devices which are then allocated to the training activities.

Since the Fleet Training Center has an electronics section, much of the installation and care of the equipment is accomplished by this group. For major installations, however, such as the recently installed SX radar, the shipyard is required to furnish personnel as well as material to make the installation. After installation is completed, the problem then becomes one of obtaining needed replacement parts and furnishing technical advice and assistance when needed. Calls of this type very often conflict with the schedules set up for regular yard work on vessels undergoing overhaul, but at no time has a call been turned down. The Fleet Training Center has therefore been able to accomplish a maximum of training with the facilities available.

The major portion of the electronics equipment is installed and in use in the Combat Information School. This school, which conducts classes under Lt. Comdr. W. B. Woodson, Jr., USN, covers all phases of C.I.C. work and is laid out to include representative mock-ups of the C.I.C.'s installed on board destroyers, cruisers, CV-type carriers and CVB-type carriers. It is in

this latter type that the installation is "live," as distinguished from the "canned" or mock-up installation in the other types.

The CVB C.I.C. utilizes the SX radar for training purposes and the placement of the various components is as close to shipboard installation as can be effected ashore with the facilities available. This C.I.C. is in use not only for training regular personnel, but is used two week-ends each month for the training of the reserve personnel attached to CVE Groups 60 and 62.

The installation includes the type VJ radar repeaters and utilizes both m.h.f. and v.h.f. for communication with aircraft used in conjunction with air exercises of various types. An interesting phase of the use of this installation is in connection with finding an aircraft which may become lost in poor weather conditions and vectoring it to within range of a nearby G.C.A. unit which can then land it.

For "canned," or predetermined problems, ranging from radar navigation to shore bombardment, the school combines electrical as well as electronic devices. Dead reckoning tracers are used in the combats, motivation being obtained from course and speed transmitters controlled by instructor personnel from the remote station known as the Problem Control Room.

All combats are fitted with 21MC units, as well as simulated TBS and v-h-f circuits, which latter utilize individual audio amplifiers.

The various types of trainers in use, or being installed, include the OCJ and OCZ, which permit target presentation on an SR radar console, the multiple D.R.T. plotting table, Device 15-K4, which permits training of twenty-four students at the same time in basic plotting. The Radar Target Generator, Device 15-J-1b, permits the use of VC, VD and VE types of radar repeaters for aircraft interception work. Plotting tables and boards, identical with those installed on board ship, are used for summation purposes.

The Anti-Submarine Warfare School, with Lt. T. Sterniuk, USNR, in charge, instructs in all phases of anti-submarine warfare, utilizing the Sangamo attack teachers and associated equipments. In addition, this school offers a course in emergency ship handling, which includes the use of a target light aspect board which is controlled by the instructor to show the student the light aspect of an approaching vessel as it might appear at night from his bridge.

The countermeasure courses use standard equipments found on board ship. New equipments will be installed as they become available in order to familiarize fleet personnel with their use.

The Radio Operators School, Chief Radio Electrician

B. E. Beall, USN, in charge, instructs recommended fleet personnel in typing and code, and produces radiomen over a period of time determined by the individual himself. The Automatic Keyer, Device 11-C-3, which is controlled in its speed, is the medium used to increase the proficiency of the students. This school capably handles the area drill circuit, holding daily drills in voice and c.w. and offering constructive criticism to the fleet units participating.

The other schools use electronic units of various types

for communications and training, but not to the degree noted for other schools.

It is estimated that over \$2,000,000 in structures and equipment have gone into the establishment at Norfolk. This investment pays dividends in the form of sharpening the abilities and talents of seagoing personnel.

The local electronic unit and the shipyard have combined to make this installation pay off handsomely. The Fleet Training Center is passing an estimated 15,000 students, officers and men, through its classes each year.

## DAMAGE TO MODEL QGA TRANSDUCER CABLE

During installation of the transducers of the CBM-78222 Hoist-Train-Tilt Mechanism of the Model QGA Echo Ranging Equipment, the transducer cables are pulled tightly between the stuffing tubes at the slip rings and the underside where they emerge from the holes in the transducer mounting bails. The inside ends of the packing glands present relatively sharp edges to the soft rubber insulation of the transducer cables. When the cables are pulled tightly across these sharp edges the rubber is mashed almost to the wires (see the left-hand section of figure 1). Salt water soon penetrates this thin insulation, permanently damaging the cables.

Also, during installation, the gland nuts are often fastened too tightly, squeezing the rubber packings so that the soft rubber insulation is mashed very thin all around the wire of the cable. Since salt water is present at the ends of these packings, leakage and permanent damage also develop at these points. This condition also is shown in the left-hand section of figure 1.

These conditions have been found on ships just being completed. In several instances the insulation parted at the rubber packing and slipped on the wire when pulled

outside of the packing gland. To prevent the first condition, the packing glands should be altered slightly by removing the sharp edge, so that severe damage during installation would be avoided. The second condition can be avoided by tightening the packing nuts only finger tight. Tests have shown that this much pressure on the rubber packings is sufficient to permanently exclude the water.

The right-hand section of figure 1 shows corrections for both these faults. The packing gland has been reshaped at the hole to allow the cable to assume a natural bend. The cutaway is the metal removed in reshaping. To prevent the cable from pressing against a sharp edge, a stainless-steel washer is added to align the cable in the hole. The packing nuts are fastened finger tight so that the insulation remains in good condition.

Even though all, or almost all, QGA installations are now completed, new cables will need to be installed at various times in the future. The methods outlined in this article may be instrumental in prolonging the useful service of these new cables.

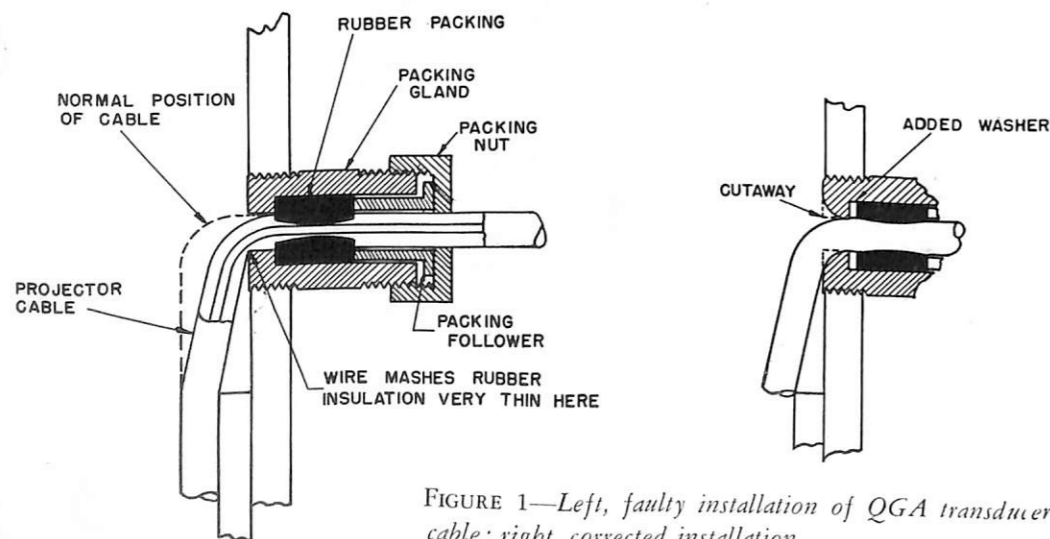

FIGURE 1—Left, faulty installation of QGA transducer cable; right, corrected installation.

## THE 120-INCH SONAR DOME AND RETRACTING GEAR

By S. F. POLLARD

A prototype of the 120-inch sonar dome and retracting gear which is presently being installed in the U.S.S. *Saipan* (CVL-48) at Norfolk Naval Shipyard promises to be a vast improvement in echo-ranging hull units for surface vessels. It will house the transducer of a Navy Model QHB Scanning Sonar Equipment. The dome approaches the ideal in proportion for minimum turbulence, thereby allowing improved operation of the equipment with increased ship speeds. It can be completely retracted within the ship's hull when not in use, which eliminates the hazard to navigating and anchoring in shallow waters presented by the non-retractable types. The gear was designed and constructed at Boston Naval Shipyard and shipped to Norfolk for installation.

The various types of sonar domes in current use were adopted during the late war. The 54-inch dome and retracting gear was developed from an original British design, and the 50-inch design is similar. These types were a considerable improvement over the older 57-inch non-retractable type, but all of them were too short and thick for quiet operation at ship speeds above 15 to 18 knots.

The 100-inch dome used with QGA and QHB equipments is non-retractable. While an improvement in streamlining, it presents a serious navigational hazard, particularly when installed in capital ships. The U.S.S. *Mindoro* (CVE-120) equipped with a dome of this type found it necessary to anchor 12 miles out when at Key West so that the parabola of the anchor chain would be sufficiently vertical to prevent fouling the dome. In addition they had to keep up steam and maintain a full engine room watch as a further precaution against swinging over the chain from sudden change of wind direction. To anchor closer to shore would have made it necessary to keep the engines constantly backing down.

From experiments conducted at the David W. Taylor Model Basin, it was determined that a dome must have a length-to-breadth ratio of not less than five to one, if adequate reduction of turbulence is to be provided. To house a standard 19-inch sonar transducer and provide the necessary clearance and thickness of window stiffening, a dome length of 120 inches is necessary to conform to this ratio. Since this dome is more than twice as long as any previous retractable dome, an entirely new type of retracting gear had to be developed to raise and lower it.

The new retracting gear developed by the Boston

Naval Shipyard for use with the 120-inch dome is of excellent design. The designers departed from the old method of hoisting and lowering by long jack screws, and adopted a rack and pinion system. The dome is supported by two large vertical cylinders that travel up and down between guides inside the trunk and extending into cylinder housings above the trunk. The cylinders have spur gear racks on two opposite sides which mesh with four spur gear pinions that in turn are driven through a slip clutch by a 5-h.p. gear motor. The cylinders are locked in their hoisted and lowered

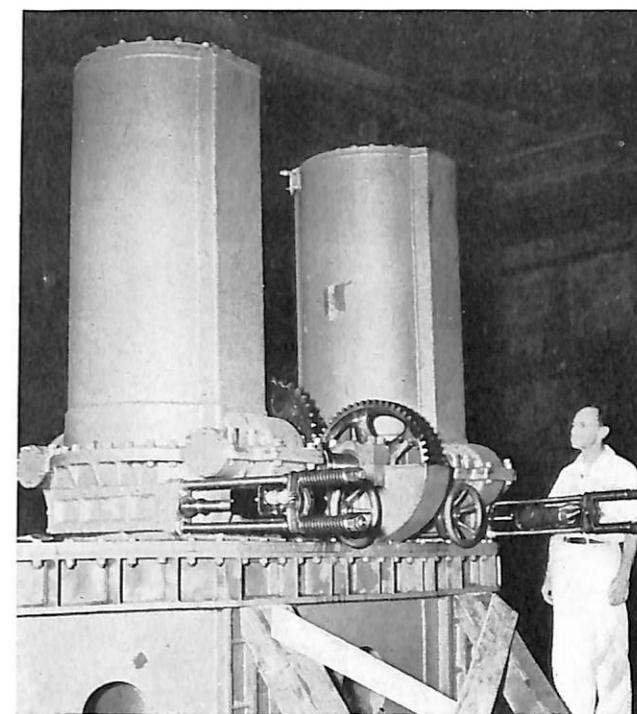

The 120" Dome Retracting Mechanism prior to installation.

positions by motor-driven wedges. The transducer is secured to a support called a "stop and lock device" that locks into the lower end of the forward cylinder. With the dome hoisted and the tops of the cylinders seated against gaskets in their housings, the transducer can be removed through the cylinder for servicing with the ship waterborne.

Another interesting feature is the slip clutch used in the hoisting drive. It incorporates a motor-actuated positive drive lock that engages to prevent slippage during hoisting and lowering. The lock disengages when ap-



proaching the limits of travel, allowing the clutch to slip as the hoist motor continues to drive the mechanism against the stops while the wedges are being actuated.

The 120-inch dome utilizes the standard type of window construction, the 20-mil stainless steel bracked with expanded metal, and horizontal and vertical stiffeners. It differs, however, in that no baffle is used.

Another feature of the new retracting gear that is important from a maintenance standpoint is the relatively large clearances permitted between the mating members of the vertical guides. These guides are of the sliding type and are initially provided with clearances of 1/32 inch. The stops for limiting downward travel are particularly rugged and are non-adjustable.

For several reasons it is obviously desirable to have the sonar dome protrude from the hull of the ship on its fore and aft centerline. The problem presented by selecting this location, while not novel, is interesting in that a section of the ship's keel, the backbone of the ship, has to be removed. A shell or seachest, open at both top and bottom, is constructed to fit the contour of the retracting gear trunk and installed in the opening. This shell is of very heavy construction and the structures on both sides of it are heavily strengthened so that, finally, the ship is actually stronger in this area than it was originally. The *Saipan* will lose approximately ten and one half feet of its keel in order to accommodate the 120-inch retracting gear.

*Cut away and plan view, showing position aboard ship of the 120" retractable dome.*

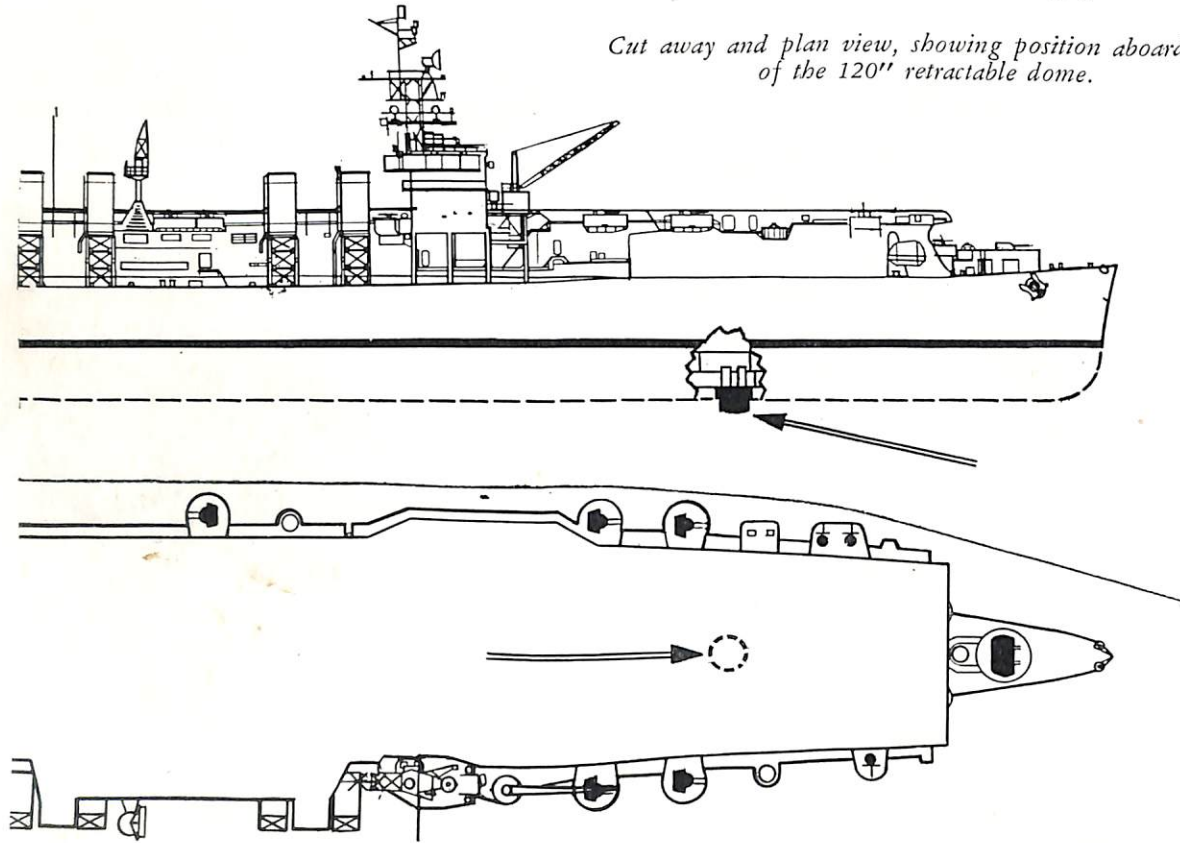

★ ★ THE AUTHOR ★ ★ ★ ★ ★ ★ ★

Sidney F. Pollard, Jr. was born in Norfolk, Virginia on February 3, 1911. Mr. Pollard attended grammar and high schools in that city. During 1938 and 1939 he worked as a radio technician at the Central Radio Company, a Norfolk affiliate of the Mackay Radio and Telegraph Company.

Mr. Pollard began his shipyard career in 1939 as an electrician in the electrical shop. In 1941 he transferred to the Electronics Office as a Radio Inspector and worked in radio and sound work during the war years. At present he is the engineer-in-charge of the Sonar Group, Ships Section, of the Electronics Office.



## FACTORS AFFECTING U-H-F PERFORMANCE

By J. H. FINNEGAN

With the advent of ultra-high frequency installations for communication purposes in Naval ships and shore stations, the antenna location problem has become increasingly difficult. Very limited ranges have been reported in many instances when v-h-f equipments being supplanted by the u-h-f equipments gave very satisfactory performance; it is natural that equal or better performance is expected of the new u-h-f equipment.

Experience has shown, as theory indicates, that extreme care must be exercised in selecting u-h-f antenna locations. Of great importance is the fact that the antenna must be "in the clear." This means that mast structures, stanchions, other antennas, railings, stacks, and other metallic structures affect the antenna pattern. In shipboard installations, it is very desirable to cover 360° in azimuth with both the transmitting and receiving antennas. If this can be accomplished, transmitted signals will be received with the same strength at a given distance regardless of the respective headings of the

ships. Practically, if the change in signal strength can be maintained within 5 db at all azimuths for a given distance, the antenna location is considered to be good. Of primary importance, of course, is obtaining sufficient signal strength at the receiving antenna. Sufficient signal strength involves the amount of noise present on the frequency of the received signal so that ultimate results are contingent on the signal-to-noise ratio.

In order to obtain what approaches full coverage in azimuth and also give usable signals at ranges from fifteen to twenty miles, the necessity of having the u-h-f antennas as high as possible cannot be over-emphasized.

As a result of having to vie for favorable or the more-favorable positions with the YE homing equipments, the racon equipments, and radar equipments, it has become necessary in some instances to accept compromise locations for the u-h-f antennas. Figure 1 shows the arrangement of the antennas on the topmast of the *U.S.S. Midway* (CVB-41) before alteration to give the Model SG-6 radar the top position. Figure 2 shows the

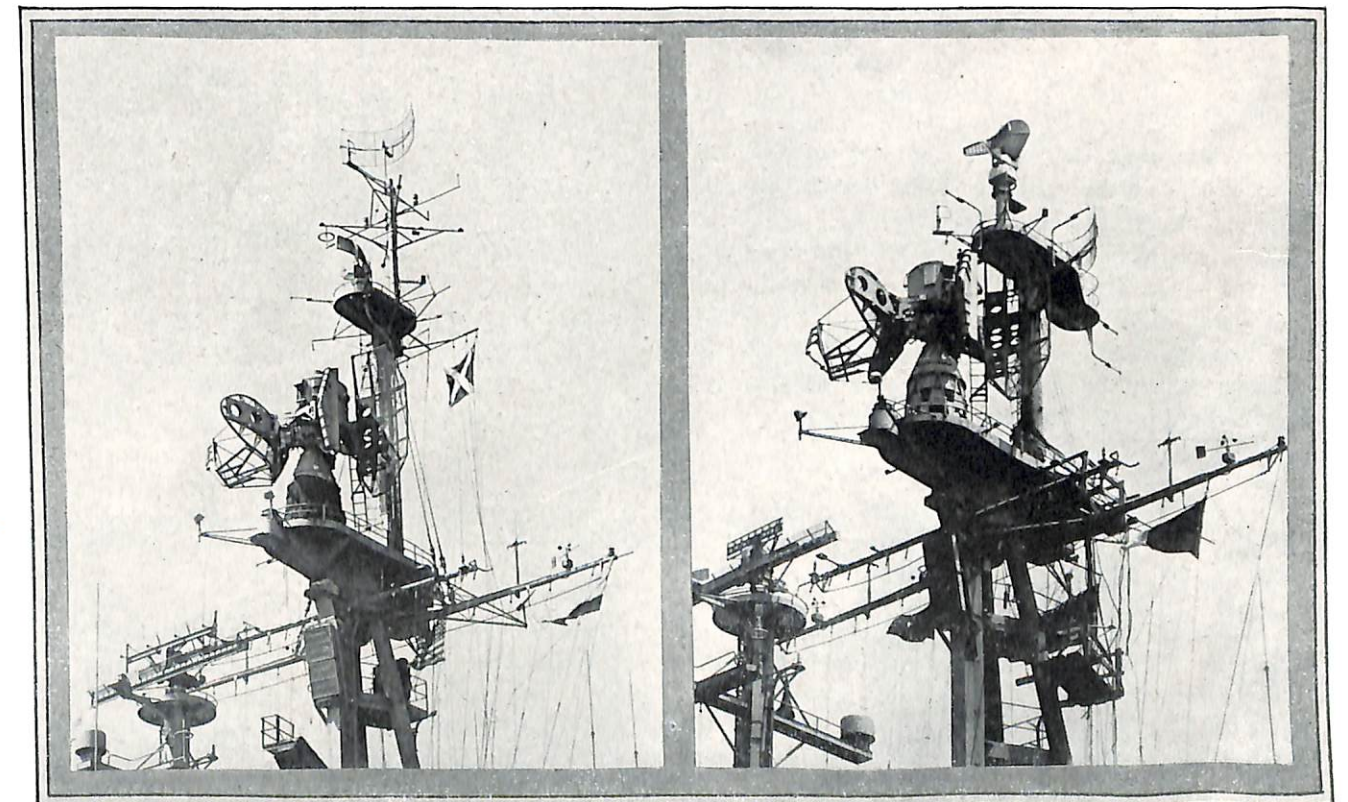

FIGURE 1—Mast of the *U.S.S. Midway*, showing the Model YE-3 Antenna occupying the highest position.

FIGURE 2—Mast of the *U.S.S. Midway* showing the Model SG-6 Antenna occupying the highest position.

previous arrangement in which the top position was occupied by the Model YE-3 homing equipment. Operational tests will be conducted to determine the effect of lowering the YE-3 antenna and the effect of the SG-6 mast on its directional pattern. It will be noted that the u-h-f and v-h-f antennas are high (143 feet approximately from waterline), but are not too well in the clear.

When it is realized that the actual power received by the transmitting antenna is only about 20 watts from a Model TDZ transmitter, the importance of good antenna locations becomes apparent. If the power output of the TDZ is taken as 40 watts, the power losses encountered are:

Loss due to type 53349 r-f filter:

$$40 \times 25\% = 10 \text{ watts loss}$$

Loss due to 100 feet of RG 18/U transmission line is about 2 db:

$$40 - 10 = 30 \text{ watts input to RG/18U cable}$$

$$2 = 10 \log \frac{30}{P_0}$$

$$0.2 = \log \frac{30}{P_0}$$

$$10^{0.2} = \frac{30}{P_0}$$

$$10^{0.2} P_0 = 30$$

$$P_0 = \frac{30}{10^{0.2}} = \frac{30}{1.58} = 18.9 \text{ watts}$$

Losses also occur due to the UG-type coaxial connectors used and the standing waves present on the RG18/U transmission line.

In the past, the familiar type 66147 has been the only type antenna supplied for installation with the TDZ, RDZ, MAR, and RDR equipments. The schematic diagram of this antenna is shown in figure 3. This antenna can be used over the frequency range 225-400 Mc, but standing wave ratios of 2.5 to 1 or

greater will be obtained at some frequencies. If it is realized that when an antenna with an impedance of 50 ohms is mounted so as to be coupled to a resonant conductor, that the impedance is no longer 50 ohms, but somewhat lower value, the coaxial line with a 50-ohm characteristic impedance will not be properly terminated. In fact, it is not necessary that the antenna be coupled to a resonant conductor. Any coupling between the antenna and a metallic object will change the antenna's impedance. The amount of change is contingent upon: 1—length of conductor in wavelengths; 2—coupling to antenna, i.e., spacing and orientation; 3—type of antenna; 4—conductivity of metallic object.

This means that a half-wave dipole antenna cut for a frequency in the 225-400 Mc range will not represent a 72-ohm termination for a transmission line if the antenna is mounted within proximity of the stack or mast of a ship.

With the exercise of sufficient care in selecting antenna locations and a thorough knowledge of the u-h-f equipment to afford proper operation and maintenance, good results can be expected and obtained.

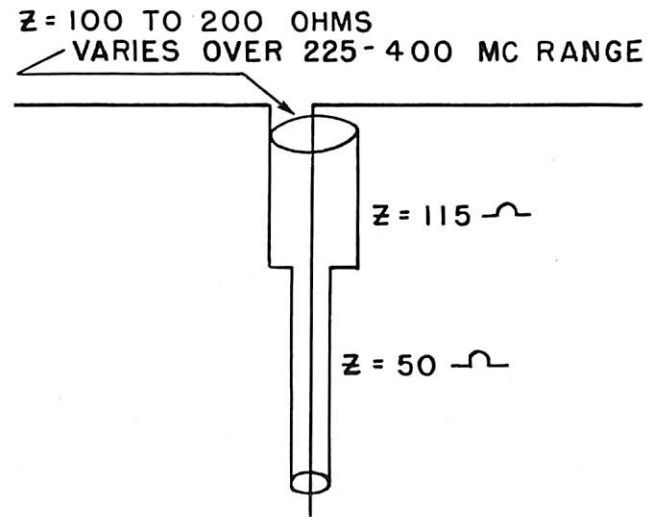

FIGURE 3—Schematic diagram of Type 66147 Antenna.

# DYNAMIC FREQUENCY-SHIFT SPREAD MEASUREMENTS AT HIGH FREQUENCIES

By personnel of U.S. Navy Communication Station, (High-Power Radio Station), Annapolis, Md.

At the present time dynamic frequency shift measurements (while a transmitter is keying) are reliably made at Annapolis by a combination of radio receiver, audio oscillator, and cathode-ray oscilloscope.

The oscillographic method of measuring "spread" described in the February ELECTRON by Commander E. H. Conklin is excellent for low-frequency work, being first used on radio teletype tests on 88.5 kc between the Naval Communication Station at Annapolis and the USS Macon in December, 1946. It is not so easy to use on the high frequencies, however; the instability of transmitters and receivers combined, though a very small percentage of the emitted frequency, is sufficient to cause shifting patterns on the cathode-ray oscilloscope.

Measurements at Annapolis show combined transmitter and RBC-2 receiver instability of 20 cps to be common. The change in frequency is often sudden. For this reason, and because of the large number of routine

servation of oscilloscope patterns, fulfills this requirement.

The method used at Annapolis is speedy, combines simultaneous aural and visual monitoring of the signal during measurement, involves no computation, and possesses the requisite accuracy consistent with the frequency stability of transmitters used at shore stations. The equipment used includes an RBC-2 receiver, a Navy type LAJ audio oscillator calibrated directly in frequency, and a cathode-ray oscilloscope. The receiver uses a doublet antenna resonant to 5 Mc (for use on WWV and local signals) with coaxial transmission line to reduce noise effects. The receiver audio output is paralleled to a speaker and the vertical plate input terminals of the oscilloscope. Horizontal sweep is provided the oscilloscope by the LAJ oscillator.

Measurement procedure is as follows:

- 1—Tune in signal using RBC-2 dial calibration. The keyed frequency-shift signal appears as shown in figure 1.
- 2—Zero-beat one signal, either mark or space, using

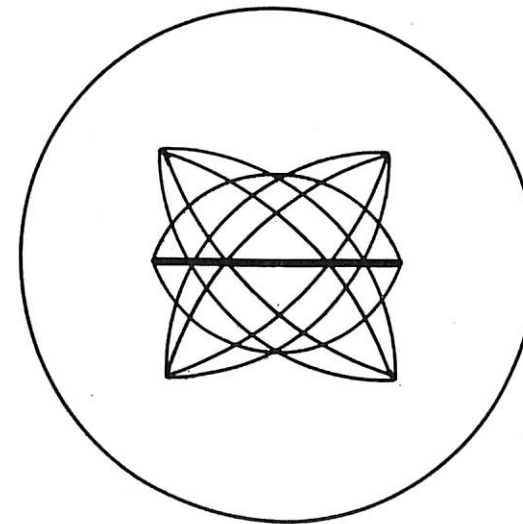

FIGURE 1—Typical appearance of keyed f-s signal on cathode ray oscilloscope.

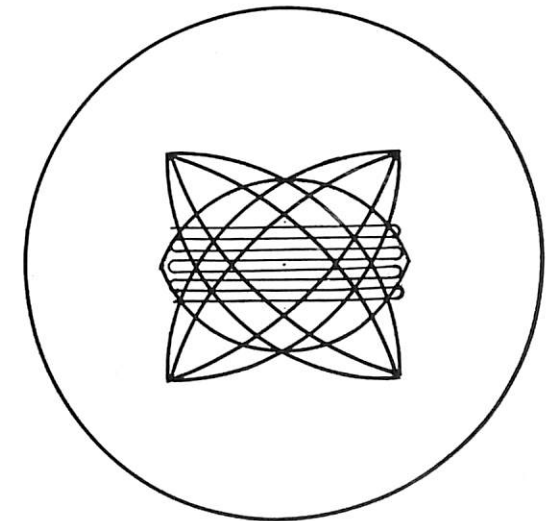

FIGURE 2—Keyed f-s signal with one tone tuned to zero beat.

spread measurements required at a major station, the measurement procedure must be quick and free of arithmetical computations. It is also a requirement that the signal presentation of the measuring equipment must unmistakably show when noise or interfering signals make reliable measurements impossible. Aural monitoring during measurement, combined with the visual ob-

the vernier tuning control. Signal will appear as in figure 2.

- 3—Adjust LAJ frequency until CRO screen shows a circle or ellipse super-imposed over the horizontal line, as in figure 3.
- 4—Read the frequency of the LAJ. This is the spread between mark and space signals.

★ ★ ★ ★ ★ THE AUTHOR ★ ★ ★ ★

JAMES H. FINNEGAN

James H. Finnegan was born 19 December 1916 in Richmond, Virginia and attended both the grammar and high schools of that city. He studied electrical engineering at the Virginia Polytechnic Institute, Blacksburg, Virginia, receiving his B.S. degree in 1939.

Mr. Finnegan entered the shipyard in 1939 as a Radio Engineer and has worked in "radio" for a number of years. He is the engineer-in-charge of the Ships Section of the Electronics Office.



Operators carry out this procedure in 10 to 20 seconds.

Accuracy of measurement depends on the amount of care spent in adjusting the receiver to zero beat and in reading the LAJ. A series of spread measurements to determine accuracy was made by alternate measurements using the above method and the visual comparison method described in the February ELECTRON. At the same time, measurements were taken which indicated the combined transmitter and receiver frequency drift during the time of each pair of spread measurements. Results of a typical series of measurements are given below:

Annapolis method	Visual Comparison method	Difference Frequency	Frequency Drift
850 CPS	870 CPS	20 CPS	10 CPS
850	860	10	25
875	890	15	5
870	870	0	5
870	870	0	0
860	860	0	0
860	870	10	10
850	865	15	10
870	860	10	10

It is apparent that either method of measurement of spread is sufficiently accurate for measuring nominal 850 cps spread. The "Annapolis" method is preferred locally because it takes half as long to measure spread, and direct readings of spread are obtained with no computation.

*Bureau comment.* The system described in the subject article is probably the best present-day method of dynamically measuring frequency-shift spread. It is quite satisfactory for use at Annapolis and other land stations which are fitted with the Navy Model FSA Frequency-Shift Keying Adapters and other keyers which are equally stable on "mark" or "space." Certain other key-

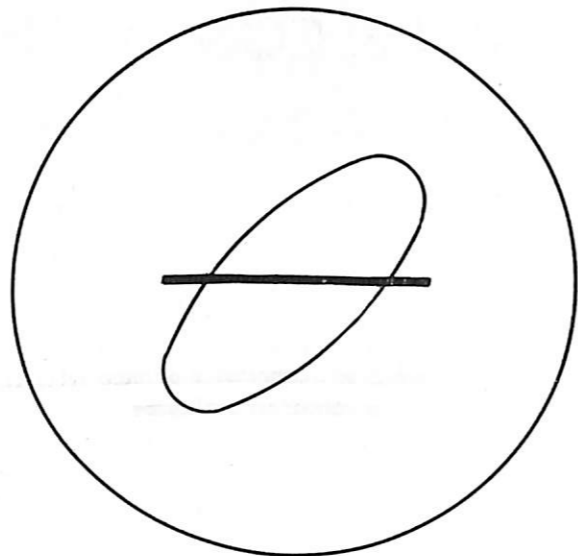
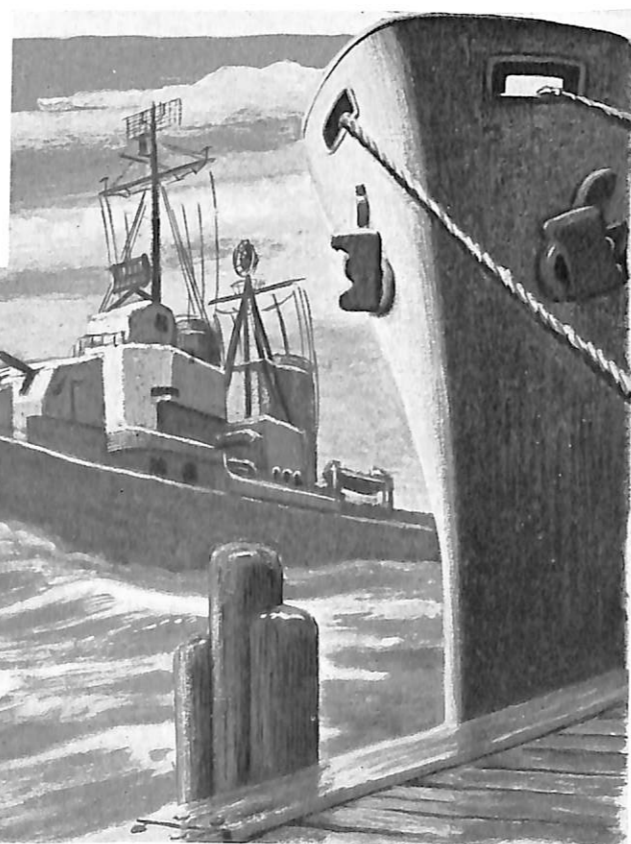

FIGURE 3—Keyed f-s signal with one tone at zero beat; sweep frequency adjusted equal to frequency of other tone.

ers, however, such as the FSB, are not so stable; stations employing these unsymmetrical keyers should take care in the use of the described system, for unsatisfactory or even misleading results might be obtained from them at transmitter frequencies above 12 Mc.

Shipboard use of this system is not recommended because of the bulkiness of the equipment involved.



## MOBILE COMMUNICATION EQUIPMENT

By J. B. LEE

Mobile communication equipments as used by the Navy and the Marine Corps were practically non-existent before World War II, but increased greatly in number during World War II and are becoming more and more necessary as forces become more mobile. These mobile communication units are usually trailers, semi-trailers or trucks with van bodies built thereon. The mobility of the equipment is for the purpose of transportation only, as operation can take place from a fixed position only, due to the extent of the antenna structures required for efficient communications.

The Norfolk Naval Shipyard was requested by the Bureau of Ships to provide a prototype set of mobile vans to incorporate radio teletype and communication circuits to operate between land, ship and air groups. They were to incorporate improvements based upon wartime communication experience. The completed prototype installation was made by converting existing communication units.

One of the major engineering problems encountered in the design and construction of the vans was the antenna problem. The u-h-f and the v-h-f antennas can be mounted on standard antenna supports at a height of forty feet. The main problem, however, involves the m-f antennas. A wide-band rhombic antenna can be erected to cover a broad band of frequencies, but a rhombic antenna to cover these medium frequencies is hard to transport and erect. The only other alternative seems to be the use of a doublet antenna, using a delta-match in the antenna. These delta-matching sections are very critical in frequency and, due to the large number



Mobile communication power trailer, U. S. N. 193440. Showing PE-95G and 75 kw Diesel-driven generator.

of frequencies that this equipment operates on, pose quite a design problem. The most feasible solution, however, seems to be a quickly adjustable doublet antenna.

Aside from the antenna system, the mobile communication equipment consists of Models MBK-1, MBL-1 and PN-2 communication units. Power sources consist of two Type SLN6G2-58 trailers, with one PE-95G gasoline-driven generator and one 75-kw diesel-driven generator mounted on each trailer, two Type CAHU-10305 trailers with one Type CAJG 73029 gasoline-driven generator mounted on each trailer, one Army Type K-63 trailer with one PE95G gasoline-driven generator and one 10-kw gasoline-driven generator mounted in the motor compartment in the rear end of



Mobile communication van, Model MBL-1 U. S. N. 218816. Looking toward the rear.

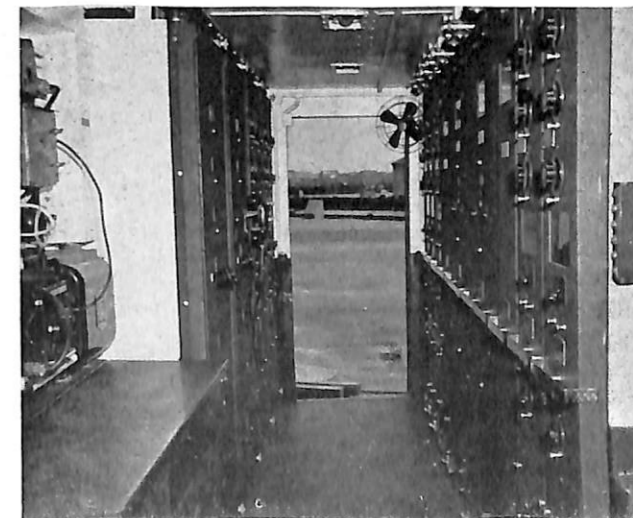

Mobile communication van, Model MBK-1 U. S. N. 193436. Rear end.



Mobile communication van, Model MBK-1 U. S. N. 193436. Front end.

the PN-2 van. Three Army Type K-53-2 1/2 ton 6 x 6 GMC trucks with canopies are used as prime movers and also to carry the antenna mast, antenna wire, spare parts and accessories.

#### MBK-1 MOBILE COMMUNICATION UNIT

The equipment in the Model MBK-1 van includes a three-kilowatt multichannel radio telephone and telegraph transmitter plus land-line and multichannel audio tone v-h-f radio link control systems, with radio teletype.

The contents of the van may be divided into three groups:

- 1—TDN-4 Radio Transmitter Equipment
- 2—Radio V-H-F Link Control and Tone Channel Equipment
- 3—Radio Teletype Keying and Monitoring Equipment

The TDN-4 major components are:

- Two transmitter r-f bays 2,000 to 5,000 kc at 3 kw.
- Two transmitter r-f bays 5,000 to 13,000 kc at 3 kw.
- One transmitter r-f bay 13,000 to 20,000 kc at 3 kw.
- Two modulators.
- Two rectifier power supplies.
- Five keying units.
- Eight master oscillators.
- Two control selector racks.

The v-h-f radio link control system consists of AN/TRC-1 components; three R-19/TRC-1 receivers and one T-14/TRC-1 transmitter (70-100 Mc FM-VHF). Four antenna systems are supplied with this equipment for either simplex or duplex intercommunication and control with allied equipments in the field. The audio tone system consists of three UG line terminal equipments.

The radio teletype keying and monitoring equipment

consists of two Model FSA frequency shift keyers, two frequency shift keyer coupling units and one Model 14 tape printer.

Modifications on the MBK consist of removing one UG line terminal equipment and two UH line terminal equipments, and installing two Model FSA frequency shift keyers, one Model 14 tape printer teletypewriter, three TT-23/SG teletype patch panels, one Type-23463 audio patch panel and one frequency shift keyer patch panel. Four Type 49269 connectors were installed in the front end of van connecting AN/TRC-1 antennas.

The TDN-4 master oscillator racks were modified by installing two TDN-4 frequency shift keyer coupler units. The TDN-4 safety neutralizing kits were installed in the five radio-frequency bays. Radio-frequency ammeters were installed in each radio-frequency bay for tuning the antenna feeders. Two Type-49194 coaxial receptacles were installed in the frequency meter panel, so as to be able to patch the LM frequency meter to the master oscillators.

Two Type SLN6G2-58 trailers are used to mount the power units. One PE-95G gasoline-driven generator and one 75-kw diesel-driven generator were mounted on each trailer.

The MBK-1 is designed to act in conjunction with its companion units, the Navy Type MBL-1 Communication Van and the Navy Type PN-2 Teletypewriter Van. When using audio multi-channel v-h-f radio link control systems, the following combinations may be handled by the existing equipment:

- 1—Five c-w or A1 circuits.
- 2—Four c-w circuits, one push-to-talk circuit, and one voice circuit for A3 emission.
- 3—Two c-w circuits, two push-to-talk circuits and two voice circuits for A3 emission.
- 4—Two radio teletype circuits, one c-w circuit, two push-to-talk circuits and two voice circuits for A3 emission.



Mobile communication van, Model PN-2 U. S. N. 226639. Showing hoisting straps and new body constructed at the Norfolk Naval Shipyard.

With the above combinations, simultaneous operation may be obtained as normal operation within separate groups. Due to the preliminary set-up of the v-h-f equipments, cross-communication cannot be made unless the control systems are changed accordingly. After the operational circuit requirements have been decided, the equipment may be set up to conform to the pattern. Any change in the requirements will necessitate minor changes in the v-h-f line-up. Under combination (3) above, there will be one transmitter radio-frequency bay of the TDN-4 available for local or metallic control from a source other than the MBL-1 unit.

The MBK-1 may be used on metallic or land-line pairs for direct control of the TDN-4 transmitter when sufficient metallic lines are available to handle all of the remote control circuits. When there is a lack of line pairs, the UG equipments may be connected into the circuit to handle specific control when remote UG equipments are available.

#### MBL-1 MOBILE COMMUNICATION UNIT

The Navy Type MBL-1 Mobile Communication Unit is primarily a package on wheels containing all of the components of a receiving station with the additional features of a v-h-f radio link multi-audio tone system, remote control of the TDN-4 transmitters in the MBK-1 and radio teletype receiving and sending.

Major modifications on the MBL van consisted of installing whip antenna insulators on the front and rear ends, one on each corner of the van. This allows four 25-ft. whip antennas to be installed immediately as soon as the van is stopped at a desired point. Installed on the front end of the van are eight Type-49269 connectors for connecting the AN/TRC-1 antennas. Installed on the rear end is an antenna box containing eleven insulators for long wire antennas. One operator's position was removed and two AN/TRC-1 equipments were installed in this space. One Navy Type-

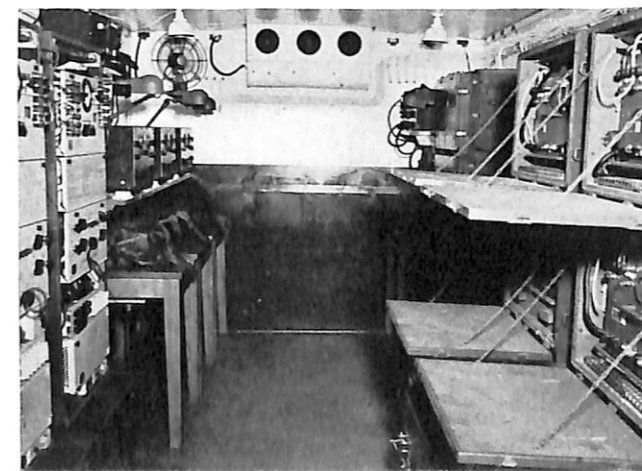

Mobile communication van, Model MBL-1 U. S. N. 218816. Looking toward the front end.

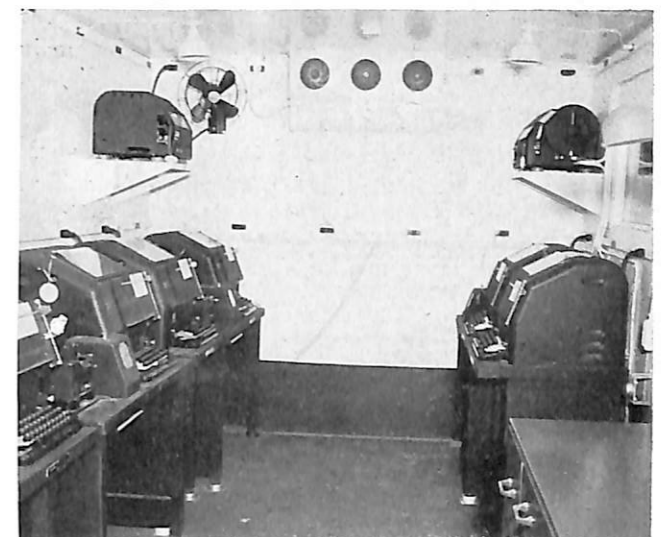

Mobile communication van, Model PN-2 U. S. N. 226639. Looking toward the front end.

50064-A line amplifier and two RBG-2 receivers were removed and the desk was modified, to permit the installation of one audio patch panel, Type-23295, consisting of 70 jacks.

Power supplies for this equipment consist of two tandem wheel trailers Type CAHU-10305 with Type CAJG-73029 gasoline-driven generators installed in each of them.

The major equipments installed in the MBL-1 are as follows:

Three RBG-2 receivers installed at operating positions for communications.

One RBG-2 receiver installed at a monitoring position for monitoring circuits, or as a spare receiver for communications.

One RBM receiver installed at an operating position for a low-frequency and a high-frequency circuit.

One Type 50064-A line equipment for utility use in conjunction with incoming land-line phone circuits or outgoing land-line phone circuits.

AN/TRC-1 equipment consisting of five transmitters and three receivers for v-h-f radio link control.

One UH and four UG terminal equipments for multi-tone channel control to be used with the v-h-f radio link system and radio teletype.

One TH-1/TCC-1 telegraph terminal equipment for use with AN/TRC-1 equipment.

One Model 15 teletypewriter for monitoring radio teletype signals.

Five Model RAO-7 receivers modified for use with radio teletype.

Two Model FRF frequency shift receiver-converters for use with radio teletype.

One remote control unit used to control the TDN-4 in the Model MBK-1 van.

When the MBL-1 is used in conjunction with the MBK-1 unit, the operations will fall in three main classifications:

1—Metallic land-line control.

- (a) Using the UH and UG equipments where wire pairs are limited due to operation difficulties.
- (b) Using straight wire control where sufficient land-lines are obtainable.

2—V-H-F radio link control with multi-tone channel system (via the MBK-1).

- (a) Five c-w circuits.
- (b) Two voice and three c-w circuits.
- (c) Two voice, two radio teletype and one c-w circuits.
- (d) Three c-w and two radio teletype circuits.

3—Ship-to-shore radio teletype (duplex).

- (a) Send and receive (duplex) radio teletype by using AN/TRC-1 with TH-1/TCC-1 (frequency 70 to 100 Mc.).

- (b) Interconnection of land-lines using the MBL-1 with the MBK-1 and the PN-2. The PN-2 van does not have any radio equipment at all; it contains nothing but teletypewriters, so it is necessary that the PN-2 be connected to the MBL-1 by land-lines. Eight pairs of cable are needed to handle the teletype signals between the MBL-1 and the PN-2. Fifteen conductors of cable are needed between the MBL-1 and the MBK-1 to handle the remote control unit, which will allow four c-w and two voice circuits. This will also turn the TDN-4 on and control all of the transmitters. Two pair on one spiral four cable are needed for the radio teletype circuit.

Frequencies available in the MBL-1 are:

- 1—Five AN/TRC-1 transmitters—70 to 100 Mc.
- 2—Three AN/TRC-1 receivers —70 to 100 Mc.
- 3—Four RBG-2 receivers —55 to 30 Mc.

- 4—Five RAO-7 receivers —55 to 30 Mc.
- 5—Five r-f bays of the TDN-4 in the MBK-1 via radio link or land-lines—200 to 20,000 kc at 3 kw.
- 6—One RBM receiver.

### PN-2 MOBILE TELETYPEWRITER UNIT

The Navy Type PN-2 Mobile Teletypewriter unit is similar to the MBL-1 in chassis and body design. When this van was received, the body was in bad condition and Norfolk Naval Shipyard built a new body.

The major contents of the PN-2 are as follows:

- Three Model 19 teletypewriters.
- Three Model 15 teletypewriters.
- Two Model 14 teletypewriters (receive-only 'typing reperforator).
- One supervisor's desk.
- One desk with typewriter.
- One storage cabinet.
- One file cabinet.
- One gasoline-driven generator located in after compartment.

Three teletype patch panels Type TT23/SG.

This van is used in conjunction with the MBL-1 van via land-line connections. Land-line terminals on the curbside of the van allow flexibility of connections between the PN-2 and the MBL-1, or the message center.

This van carries a spare power supply K-63 trailer with a PE-95G gasoline-driven generator. In addition to using land-lines to the MBL-1, you can also have land-line teletype communication with the message center or other communication headquarters or centers.

It is hoped that the vans can be returned to the shipyard at regular intervals for the overhaul of the equipment and the making of any additional changes dictated by operating experience. Now that the shipyard shops have been indoctrinated to this type of work, it should be handled on a routine basis in the future.

## MAINTENANCE OF RADIO AIDS TO AIR NAVIGATION

By R. J. BISHOP

On 1 July 1948, the Navy assumed the maintenance and operation of all Navy-owned radio aids to air navigation which had previously been maintained and operated for the Navy by the Civil Aeronautics Authority. In the Fifth Naval District this meant six fan markers and three localizers, most of which were located in outlying areas, far from other Naval activities.

Prior to assuming this new responsibility, the Norfolk Naval Shipyard sent two engineers and an electrician to a special school at Naval Air Station, Pensacola, Florida, where an intensive short course was given in the equipment they were to maintain and repair.

Unlike other electronic equipment serviced by the Navy, the fan markers and localizers were designed and manufactured to specifications of the C.A.A., and as a result vary somewhat from standard Navy specifications.

In order to assure proper operation, each aid is visited on a bi-weekly schedule; its operation is completely checked and all readings logged. If any deviation is found from previous inspections, an attempt is made to locate the cause and effect a permanent remedy. To date, the bi-weekly schedule of preventive maintenance has kept troubles to a minimum.



One of the trucks equipped by the Norfolk Naval Shipyard for making ground checks on Radio Aids to Air Navigation in the Fifth Naval District.

Ground checks are made on each leg of the localizer by a receiver mounted in the service truck. These points are located from three to five miles from the station. If any leg is found to be more than 1.5 degrees from the desired course alignment, the localizer is immediately properly adjusted. Inasmuch as the majority of the aids in the Fifth Naval District are located in swampy areas, the vegetation is checked and as soon as it exceeds

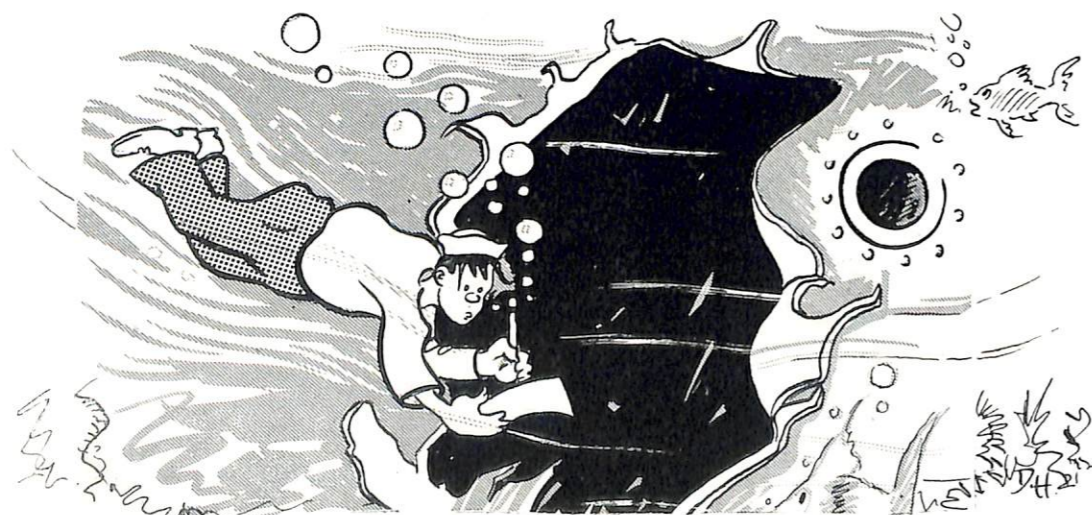

Hope BUSHIPS appreciates this failure report!

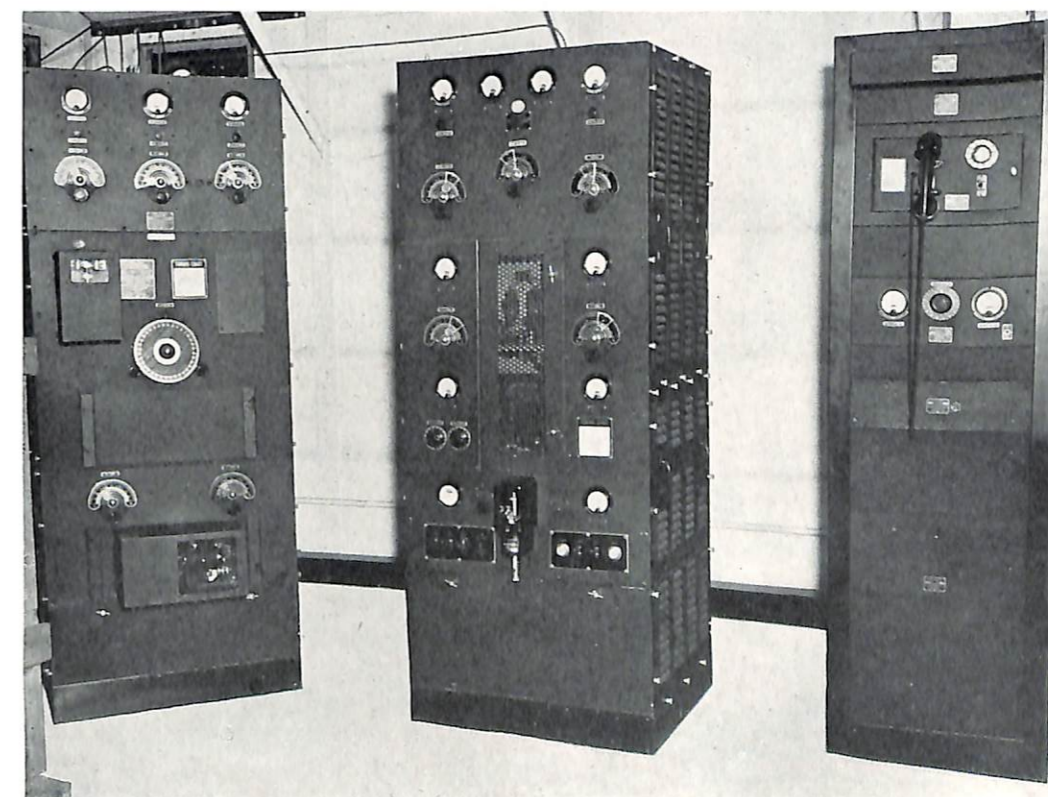

L. to R.: Antenna Tuning Unit, transmitter, transmitter control panel.

This 75 Mc transmitter sends a conical shape beam upward from the localizer site to assist the pilots in definitely establishing their location.

more than one foot in height it is cut and burned. Too much vegetation will cause course bending.

In addition to the ground checks, air checks are made at regular intervals by planes from the Naval or Marine Corps Air Station nearest the aid. To assist in making these checks, all localizer and fan marker buildings in the Fifth Naval District are now in the process of being painted white with international-orange roofs. In addition, the localizer roofs are being marked in accordance with current C.A.A. instructions.

During the summer months trouble has been experienced with lightning burning out relay coils. The only major trouble to date has been the temporary loss of one localizer's services due to a blimp coming loose from its moorings, drifting into the loop antennas and tearing the poles down.

Some of the stations are now having their wartime-built fences replaced with a modern "cyclone" type fence.

Personnel doing the maintenance work in the Fifth Naval District are well indoctrinated as to the importance of properly functioning aids. Two of them are private pilots.

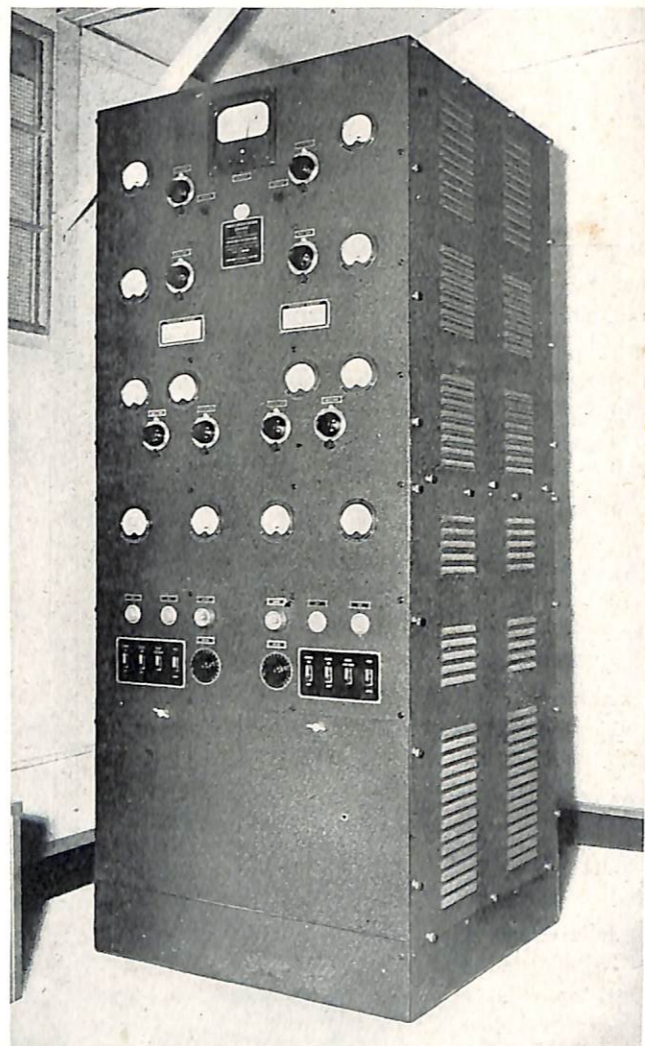

★ ★ ★ ★ ★ THE AUTHOR ★ ★ ★ ★ ★

Raymond J. Bishop was born on 12 May 1914 in Richmond, Va., and attended elementary and high schools in that city. He served two years, 1938 to 1940, as Radio Operator and instructor in the Naval Communication Reserve. He entered the Shipyard Design Section in 1940, transferring to the Electronics Office in 1942.

Mr. Bishop has specialized in air navigation aids. He is at present employed in the Radar Group, Ship's Section of the Electronics Office.

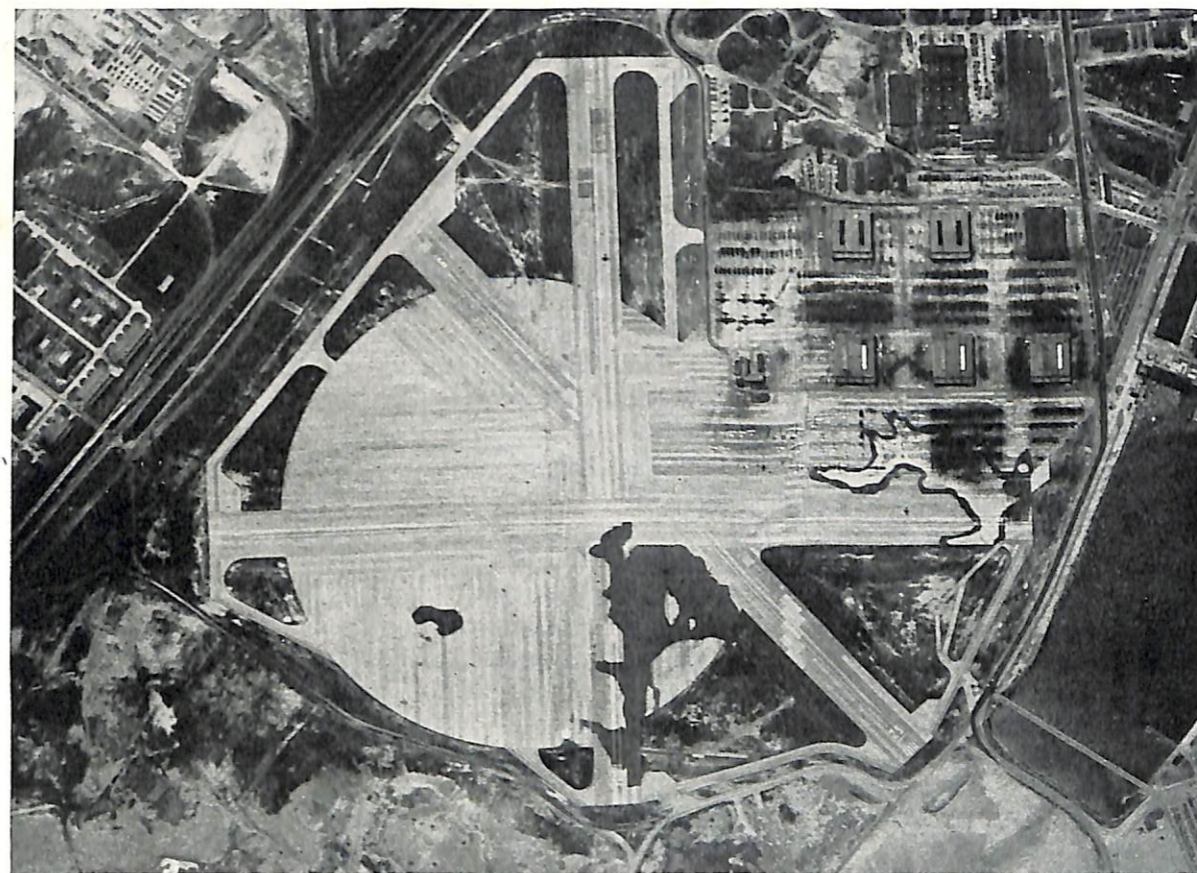

Air view of the Naval Air Station, Norfolk, Virginia.

## NEW CONTROL TOWER AT THE NAVAL AIR STATION, NORFOLK

By Lt. Comdr. L. C. Harlow, USN

Taking advantage of a two-month shutdown of East Field at N.A.S. Norfolk, the Norfolk Naval Shipyard is completely overhauling and renovating the control tower equipment at that station. This process will result in an entirely new control tower design as well as the elimination of certain "hay-wire" which accumulated during the war years. The new design will permit the tower to handle a much greater traffic load than any other control tower in the United States. This tower will be one of the first Navy control towers to conform to the new Air Force-Navy-C.A.A. specifications. It will be operated in accordance with the new joint procedures for the control of air traffic.

The plans for the new tower were drawn after a study of other active towers with a similar traffic load, such as New York's La Guardia and Idlewild fields,

and the Washington National Airport. Unlike the above-named fields, the traffic at East Field, with the exception of a few M.A.T.S. flights, is all non-scheduled. To further complicate the problem, the majority of the pilots are less familiar with the field.

The external appearance of the Operations Building is being changed by the erection of a radar tower to elevate the Model AN/TPS-1B antenna. This tower will be erected in a blind spot for communications, for operating experience has indicated that it is not practicable to operate radar antennas firing directly into the adjacent radio antennas. Shock excitation causes too much interference.

Inside of the tower the layout is being changed. Instead of one or two positions doing all of the traffic controlling, there will be three control positions with facilities for four controllers. Each controller will have

his own microphone and control keys. Where required, warning lights are being placed opposite each key to indicate the channel selected and whether it is being used by the local position or another position. An amber light indicates the channel selected; a green light indicates the channel is transmitting from that position; a red light indicates that the channel is in use at one of the other positions. The circuits are interlocked to prevent one operator from breaking in on another's transmission, with an additional provision for the supervising controller to over-ride any operator should the emergency require.

One of the positions is the Local Control Position. This is the key control position of the entire tower and has provisions whereby two operators can divide the load. Its prime purpose is to control a plane in the air from the time it enters the traffic pattern until it lands and turns off the runway and onto the taxi strip.

The second position is known as the Flight Data Position. This position controls traffic from the time it turns off the runway. It serves as the contact between the clearance desk, weather central, and other activities outside of the tower, with those inside the tower. It does most of the "paper work."

The third position is the Approach Control Position. It functions to control traffic from the time of the initial contact with the tower until it is cleared to enter the traffic pattern. It will control the approaches during instrument condition. In order to provide for possible tie-ins with other available aids, this position is being duplicated in a room immediately below the tower.

The placement of the speakers and controls is such that during certain periods of light traffic one or two men can properly perform all of the tower control functions.

The panel for controlling the new field lighting system is being mounted directly behind the Local Control Position, out of the way during daylight hours yet quickly accessible at all times.

Immediately below the tower is the radio receiver room. This room will contain the receivers for the various air-ground circuits. All of the radio receivers, with the exception of two tunable receivers, have been removed from the tower and are being located in this room below. Also included is a position duplicating the controls of the Approach Control Position above. This room will have the controls for the localizer and a TDZ transmitter for future use. The receivers will be of the fixed-tune type and drive the loudspeakers above. In addition, extra receivers are provided so that special circuits may be set up as required.

Another position to be in this room is the M.A.T.S. air-ground position. This position will provide a service to M.A.T.S. aircraft similar to that of the company radio of commercial airlines. It is to have radio receivers and teletypes connecting it directly with M.A.T.S. at other cities.

Below the tower level, yet reasonably accessible, is the present Operations Radio Room. This will continue to serve as the communication center of the entire Air Station. From this center all communications, other than those directly concerned with the control tower, are handled. A number of radio and teletype operating positions are provided, each of which is interconnected through the a-f/r-f distribution panel for maximum flexibility and less radio interference.

During the renovation period the teletype machines are being changed from the series-motor type to the synchronous-motor type in order to reduce interference and permit reliable operation.

In the Fleet Weather Central Aerology Office is the receiver for the AN/GMQ-2 ceilometer, the weather teletypes, and the facsimile weather map machine.

All of the radio transmitters serving East Field are located away from the control tower area. The v-h-f transmitters are located across the field from the tower. These transmitters are being equipped with new voice-operated relays designed by engineers of the Electronics Office. The l-f and h-f transmitters are located at the Norfolk Naval Base radio station almost two miles west of the control tower. The actual transmitters used are determined by operational requirements, but such types as TCC, TDO, TDH, TCA and others are readily available as required.

East Field has the first of the new Model AN/FMQ-1 400-Mc radio-sonde receivers for use with upper-air measurements. This equipment is now undergoing service tests prior to its adoption by the naval service at large.

The secret of the successful operation of the electronics equipment at the Naval Air Station has been due, in a large part, to the cooperation of the various personnel at the air station and in the shipyard. All requests for service, particularly where radio aids to air navigation are concerned, are given the very highest priority. A frequent exchange of visits is made which enables problems to be corrected before they have a chance to grow.

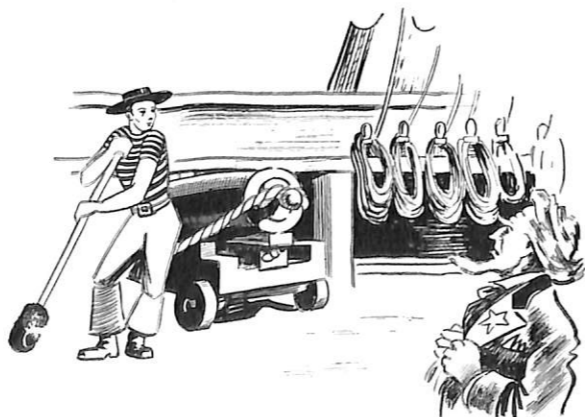

# RADAR ANTENNA STABILIZATION

By LT. COMDR. I. L. McNALLY, USN, BUREAU OF SHIPS

## INTRODUCTION

In land-based radar systems the antenna is mounted on a fixed base, and there is no problem of antenna control or interpretation of indicator data. When a radar system is operated on board ship, however, the control of the antenna and the interpretation of the indicator data are modified by the roll and pitch of the ship. The elimination of the undesirable effects due to the motion of an unstable base is accomplished by the stabilizing of the antenna in one manner or another.

Several methods may be used to stabilize an antenna, and, generally, the one used depends upon the type of antenna to be stabilized and the reasons for such stabilization. The various methods are classified according to the manner in which the axes of the antenna mount are arranged.

The stabilization of a given antenna is realized only at the expense of greater complexity in the system. Some stabilization schemes are fairly simple, requiring only a few elementary components; others are quite complicated and necessitate the use of accurate, delicate, and complex units. Some methods are capable of directing the antenna above the horizon while others cannot do so, and some can accurately measure horizontal and vertical angles while others cannot. The reasons for using a given system will be noted later in the discussions of the different stabilization methods.

## ADVANTAGES OF STABILIZATION

The primary reason for stabilizing a radar antenna is to keep the beam directed in a desired direction as the ship rolls and pitches in order to prevent the echo signals seen on the indicator from varying in magnitude. When an antenna is stabilized, however, additional advantages are realized.

The antenna beam pattern in the horizontal plane may be made narrower when the antenna is stabilized than when it is not. This is accomplished by using a larger reflector with the stabilized mount. The use of this larger reflector has the additional advantage that greater ranges are obtained with a given power output due to the concentrating of the beam.

The stabilized antenna, together with the narrow beam and the use of deck-tilt correction when necessary, in the train information fed to the mount results in greater bearing accuracy. (Deck-tilt correction will be explained in a later section.) The use of one-speed synchro data and a second higher-speed synchro data also aid in obtaining greater bearing accuracy. The one-speed data is used for the main positioning of the antenna while

the higher-speed data is used for the fine controlling of the antenna near the zero or null position of the one-speed system.

The stabilization of the antenna permits elevation angles to be measured accurately. Until recently the only systems which have been stabilized have been those in which target elevation angles were to be measured. In such systems, stabilization is a necessity.

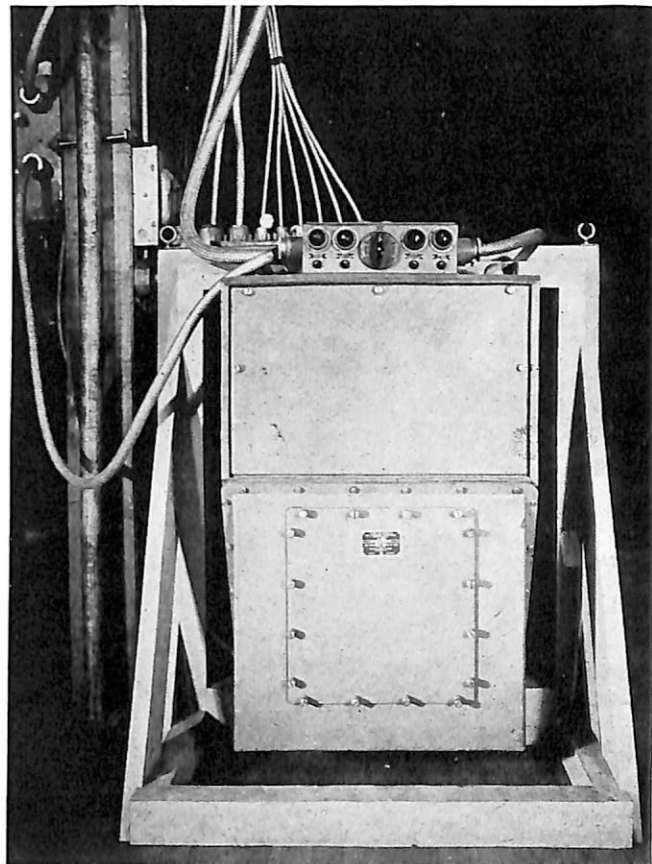

Typical computer and DG synchro amplifier for a stabilized antenna system.

## METHODS OF STABILIZATION

There are four principal systems being used at the present time to stabilize radar antenna mounts; namely, the line-of-sight, the two-axis, the three-axis, and the stable-base systems. (Terms used in this article are defined in the "Glossary" at the end of the article.)

The line-of-sight system is the simplest of all the systems, and compensates for the roll and pitch of the ship by changing the elevation of the reflector to keep the beam directed toward the horizon. The mount permits the antenna to be rotated in train and raised or lowered in elevation. Deck-tilt correction is not used in this system.

The two-axis system is similar to the line-of-sight system except that provision is made for adding the deck-tilt correction to the train information fed to the mount. Rotation occurs about two axes; namely, the level axis and the train axis. The line-of-sight and two-axis mounts are mechanically simpler than the other types of mounts, and generally require less weight at mast height than the others. With the two-axis mount, the antenna can be directed to any direction in space, but a complicated computer must be used to determine the correct information to be fed to the mount in order to compensate for the deck-tilt error as the ship rolls and pitches. If the antenna is to be used for surface search only, the complexity of the computer is somewhat reduced.

The three-axis system uses a mount which has freedom in train, level, and cross-level. Elevation angles may be measured accurately with this system since only small train angle errors and no elevation angle errors result even when deck-tilt correction in the train information is omitted in the operation of the system.

The stable-base system consists of a stabilized platform or base mounted in a gimbal system which is stabilized by rotating the roll and pitch axes of the gimbal system through the roll and pitch angles, respectively, of the ship. A vertical, relative-bearing or train axis can then be mounted on the stable platform thus obtained. Such a system is referred to as the stable-base three-axis system. If sky coverage is required, a fourth or elevation axis is added, and the stable-base four-axis system is obtained. No computer to obtain deck-tilt correction is necessary with either stable-base system. The stable-base system differs from the three-axis system in that in the stable-base system the spinner base and azimuth drive are above the stabilization mechanism while in the three-axis system, they are below it.

## ELEMENTS OF STABILIZATION SYSTEMS

The principal elements of a stabilization system are shown in figure 1. This diagram does not apply to all stabilization systems since the system shown re-

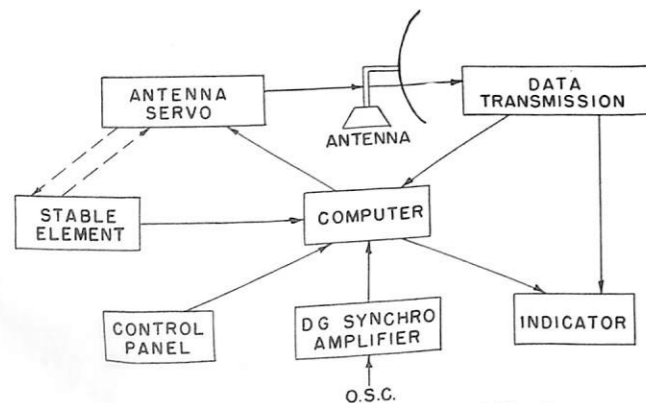

FIGURE 1. Principal elements of a stabilization system using a computer and a DG synchro amplifier.

quires the use of a computer and a DG synchro amplifier. Some systems require neither of these components while others may require one or the other of them.

The antenna is driven by a set of servos which may be either electrical or hydraulic in design. Control of these servos is not accomplished directly from the control panel, but is done through a computer which transmits to the antenna servos the correct train and elevation orders.

All stabilization systems require a sensitive element to provide level and, if required, cross-level information. This unit consists of a gyroscope maintained in a vertical position by some sort of pendulous control, and appropriate take-offs for the level and cross-level information. When the unit furnishes roll and pitch information only, it is called a stable vertical. When the unit is rotated in train and furnishes level and cross-level information (which may or may not be fed to a computer), it is called a stable element.

The antenna servos may drive the stable element and in turn receive data directly from it instead of having this information pass through the computer. Data may be transmitted directly from the spinner to the indicator, or it may be necessary to have the information pass through the computer to have corrections made for roll and pitch before it is sent to the indicator. This discussion does not apply, of course, to those systems in which no computer is used, such as the line-of-sight and stable-base systems.

In systems which do not use a DG synchro amplifier, the train data transmission does not come from the antenna but comes, rather, from the control panel. This has the disadvantage that the antenna position as shown on the indicator may be different from the actual antenna position if the antenna servo system is not operating properly.

## DISCUSSION OF STABILIZATION METHODS

*Line-of-sight system.* In the line-of-sight system, the antenna is stabilized in elevation only. The stable element (a stable vertical in this case) measures directly the elevator order which is transmitted to the spinner, and often the stable element is mounted directly on the spinner. The spinner which results when this system is used is relatively simple, and no computer of any kind is required. Since no computer is used, however, no deck-tilt correction is put into the train information to the mount, and, consequently, there will be a difference between the train order and the true relative bearing of the target. This error is small when it is necessary only to scan the horizon; for example, when the roll is  $15^\circ$  and the pitch  $5^\circ$ , the maximum bearing error is  $1.4^\circ$ . If scanning is done at  $30^\circ$  elevation, the bearing error may be as high as plus or minus  $10^\circ$ . Thus on successive scans, the indications of a single

target may be as much as  $20^\circ$  apart in bearing. The presence of this deck-tilt error limits line-of-sight systems to operation at very low angles.

Another important disadvantage of the line-of-sight system is the need for high rates in the angular drives in order to accomplish stabilization. Even when the antenna is directed at a stationary target and the ship is moving slowly on a straight course, the spinner servos must operate, and often quickly, in order to hold the beam on the target. When the spinner is scanning, the elevation servo particularly must be able to accelerate very rapidly in order to hold the beam at the desired elevation. Difficulties with high train rates arise when the antenna is directed toward targets at high elevation angles. As a result, this system has a blind area overhead in which the target may well be lost simply because the servos cannot drive the antenna rapidly enough to follow the target. Thus, difficulties with servo rates and servo accelerations limit the line-of-sight stabilization system both in the speed of scanning and the elevation angle at which it can work satisfactorily.

*Two-axis system.* The two-axis system is similar to the line-of-sight system except that provision is made to compensate for the deck-tilt error. Whether it is desired to obtain complete control of the beam or to interpret data from the spinner, it is necessary to make use of a computer.

When control of the beam is desired, it is necessary to compute elevation and train orders from desired elevation and relative bearing, and the instantaneous values of roll and pitch. When it is desired to interpret data from the spinner, the reverse computation process is necessary. The computer necessary for this system must be an accurate device, and is often bulky and heavy. The need for a computer is one of the main disadvantages of the two-axis system.

The difficulties with servo rates and servo accelerations mentioned in the line-of-sight discussion also apply to the two-axis system, and are other major drawbacks of the system.

*Three-axis system.* Some of the disadvantages encountered in the two-axis system result from the fact that the antenna is not elevated in a true vertical plane since the elevation axis is generally not horizontal. The main idea in the three-axis system is to provide a third axis about which the antenna can be rotated so that it can be elevated in a true vertical plane. This axis is called the cross-level axis. As in the line-of-sight system, the spinner is controlled directly by the stable element, which can be arranged to measure both the cross-level angle needed for the control of the spinner and the level angle which is to be added to the desired elevation of the beam. For complete control of the antenna, it is only necessary to compute the train orders for the azimuth axis, knowing the desired relative bearing of the beam and the level and cross-level angles.

The computer for this purpose is simpler than that required for a two-axis system. The difference between the train order and correct relative bearing of the beam is quite small and may be ignored, thus eliminating the need of a computer entirely.

The increased complexity of the three-axis spinner and the large number of control servos required with this system are the principal disadvantages of the system, resulting in a larger and heavier spinner. When the beam is directed against elevated targets, the train rates and accelerations required are much less than those in a two-axis system. The overhead blind area is no larger than that encountered with a land-based two-axis system. The limitation on scanning rate at low elevations is essentially the same as for a two-axis system.

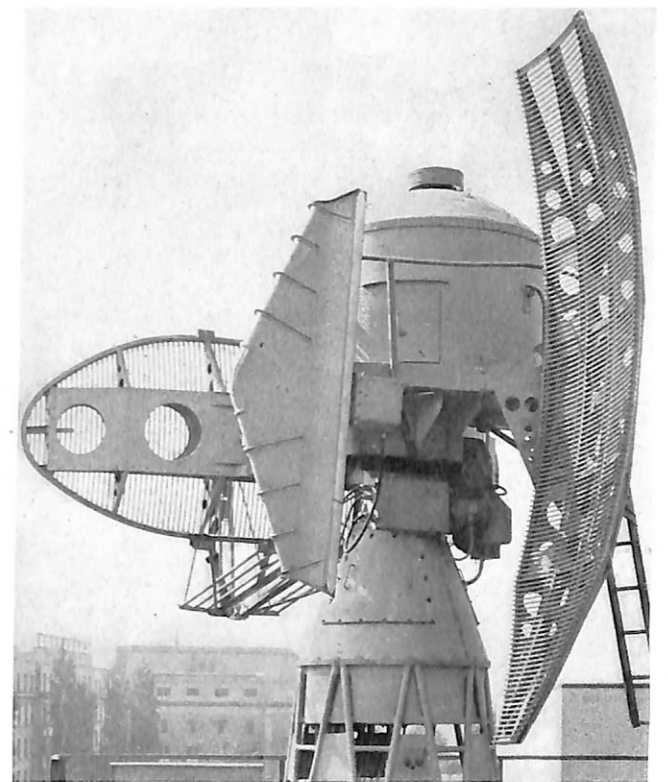

Three-axis stabilized antenna mount of the Model SX Radar Equipment.

*Stable-base system.* In the stable-base system, the spinner base is maintained in a true horizontal plane by stabilizing a platform upon which the spinner base is mounted so that it does not participate in the roll and pitch of the ship. The radar system then can perform as though it were mounted on the ground. Two degrees of freedom are required to produce this stable platform, and a third is required to permit the spinner to scan in azimuth. If it is desired to raise the beam from the horizon, a fourth or elevation axis is required. No computer is required for this system, and the scanning rates



are not limited to any greater extent than corresponding land-based systems.

Another form of stabilization is that in which the platform is partially stabilized by compensating for the effects of roll only. This system is called roll stabilization, and involves the use of a cradle swinging about the fore and aft axis of the ship. The gyro is placed on this swinging platform so that it can measure the roll of the platform rather than the roll of the ship. By introducing a servo system which is controlled by this gyro, it is possible to keep the roll of the platform very small. The pitch of the platform remains the same as that of the ship. Roll stabilization is somewhat inaccurate for ship use, since a pitch of  $5^\circ$  can seriously interfere with the scan of the horizon when a sharp beam is used. Roll stabilization is relatively more satisfactory in aircraft in which the pitch angle varies slowly and often can be compensated for by manual corrections.

### DECK-TILT CORRECTION

Deck-tilt correction can be most easily understood by a discussion of the geometry of the two-axis system.

In Figure 2 consider the radar beam to be pointing

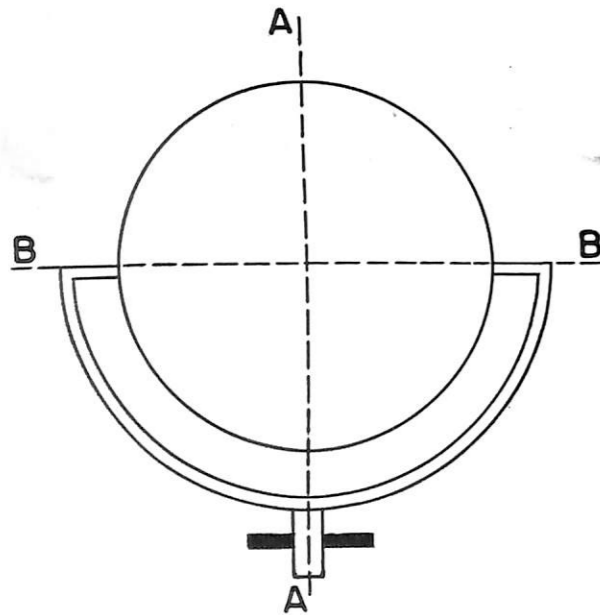

FIGURE 2. Drawing illustrating deck-tilt correction. AA is the train axis perpendicular to the ship's deck, and BB the elevation axis parallel to the deck.

directly ahead. Then if the motion of the ship is such as to cause a pitch angle to be introduced, correction to bring the beam back to its correct position is obtained by rotation about the BB elevation axis only.

In Figure 3, if roll only is introduced by the ship's motion, no correction is required since the antenna axis is still parallel to the ship's heading which has not changed. If a pitch angle is now introduced, however, correction about the BB axis is required. It will be

noted that the elevation correction will turn the antenna about the BB axis, and the beam will move along the plane represented by AA whereas it should move along the plane represented by CC in order to maintain the correct bearing of the antenna.

It is desirable to have the antenna corrected continuously, and at any instant the correct direction for the beam can be obtained by correcting about both the AA and the BB axes simultaneously.

The correction in the train angle in order to keep the beam directed at the target is known as the deck-tilt correction. The correction depends upon the roll and pitch of the ship and upon the relative bearing between the ship and the antenna. A short table from a report by H. M. James of the Radiation Laboratory, M.I.T., is given below showing typical values for this correction.

Antenna Bearing	Roll Angle	Deck-tilt correction in degrees								
		Pitch $0^\circ$			Pitch $7\frac{1}{2}^\circ$			Pitch $15^\circ$		
		$10^\circ$	$30^\circ$	$45^\circ$	$0^\circ$	$10^\circ$	$30^\circ$	$0^\circ$	$10^\circ$	$30^\circ$
$45^\circ$		0.4	4.1	9.7	0.2	0.5	1.9	1.0	1.9	1.0
$135^\circ$		0.4	4.1	9.7	0.2	0.8	5.7	1.0	0.8	6.7
Angle for max. corr.		0.4	4.1	9.7	0.2	1.3	6.4	1.0	2.7	9.1

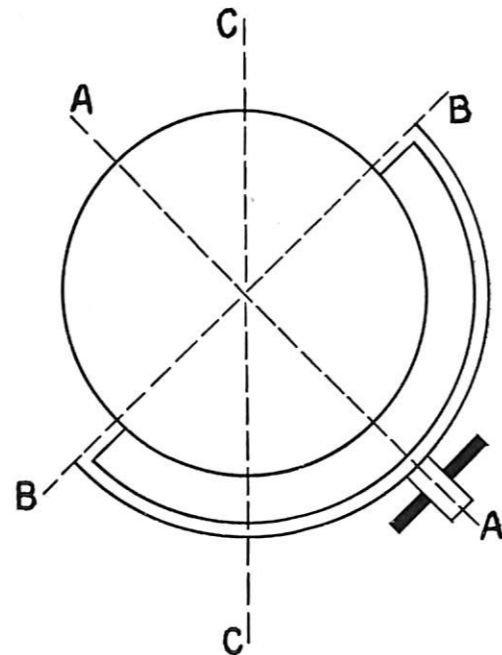

FIGURE 3. Same as Figure 2, except that ship has rolled  $45^\circ$ .

The bearing angle at which maximum deck-tilt correction occurs depends upon the relative magnitudes of roll and pitch.

### GLOSSARY OF TERMS

**Cross-level angle:** (For 3-axis stabilization.) The angle between the plane of the ship's deck and a true horizontal plane, measured in the plane perpendicular to the side of the level angle lying in the ship's deck. This quantity is positive if the right side of the deck, as seen by an observer facing the target, is raised.

**Cross-level axis:** The axis about which the cross-level angle is measured.

**Deck-tilt correction:** When the spinner base is tilted with respect to the horizontal, changing the elevation of the reflector causes a small rotation about a true vertical axis. Thus a bearing error is introduced since bearing is read directly from the rotation of the spinner base. Removal of this error is called the deck-tilt correction.

**Elevation:** Angle of the target, above or below the radar antenna.

**Four-axis stabilization:** A stable-base system in which elevation stabilization is added.

**Level angle:** (For 3-axis stabilization.) The angle between the plane of the ship's deck and a true horizontal plane, measured in a vertical plane including the line of sight to the target. This is a positive quantity if the side of the level angle lying in the ship's deck lies below the horizontal side of that angle.

**Level axis:** The axis about which the level angle is measured, normal to the vertical plane in the preceding definition.

**Line of sight:** That segment of the straight line joining observer and point of aim (on target) which terminates at observer and target.

**Line-of-sight stabilization:** A method of compensating for roll and pitch of the vessel or aircraft by changing the elevation of the spinner in order to keep the beam pointed at the horizon.

**One-axis stabilization:** Same as line-of-sight stabilization.

**Pitch:** Plunging motion of a ship so that the bow and stern alternately rise and fall.

**Pitch angle:** (For any system of stabilization.) The angle between the ship's deck and a horizontal plane, measured in a vertical plane including the fore and aft axis of the ship. This quantity is positive if the ship's bow is depressed.

**Roll:** The motion of a ship in which it inclines first to one side and then to the other; an oscillation about the fore and aft axis of the ship. Owing to the structure of the ship there is no roll without pitch, but it is theoretically possible to have pitch without roll.

**Roll angle:** (For any system of stabilization.) The angle between the ship's deck and a horizontal plane, measured in a plane perpendicular to the fore and aft axis of the ship. This quantity is positive if the starboard side of the ship is raised.

**Servo system:** A complete electromechanical system for controlling and transmitting accurate mechanical position between two points by electrical means. A relatively small amount of power is expended in controlling the large power required by the prime mover.

**Spinner:** The antenna assembly, including antenna, reflector, mount for the reflector, motors, etc.

**Stabilization:** (For radar antennas.) A system for maintaining a radar beam in a desired direction in space

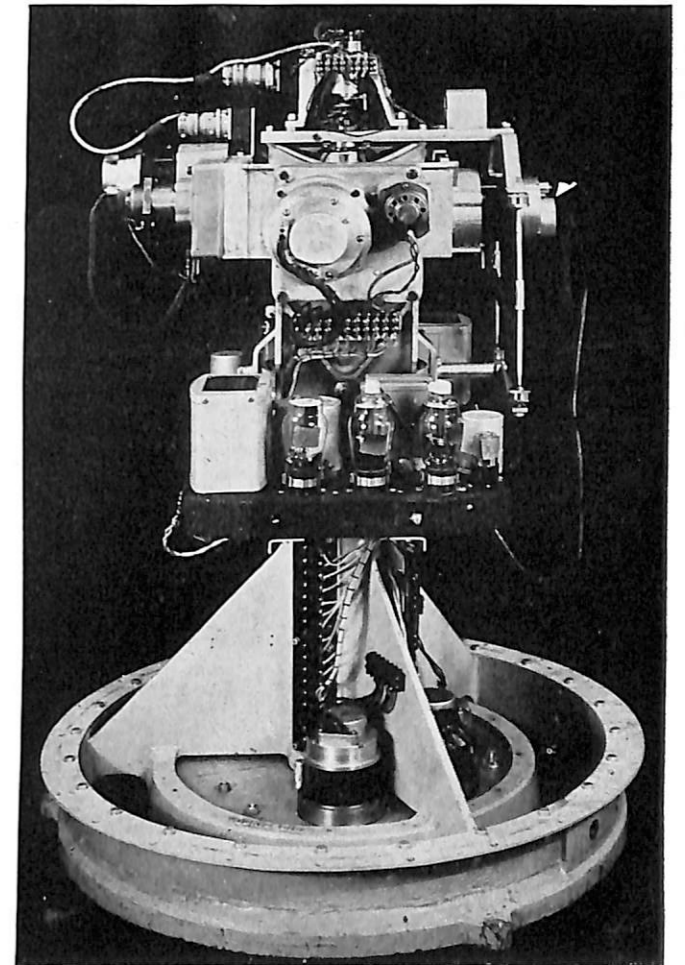

Mk 8 Mod 2 Stable Element used with the Model SX Radar Equipment.

despite the roll and pitch of the ship or aircraft.

**Stable-base stabilization:** A method of maintaining the spinner base in a true horizontal plane by compensating for roll and pitch directly. The deck-tilt error does not occur when this method is used. In a stable-base system, rotation occurs about three axes; namely, the roll axis, the pitch axis, and the train axis. If it is desired to raise the radar beam above the horizontal, a fourth axis called the elevation axis must be added above the spinner base.

**Stable element:** A gyroscopic instrument which maintains a true vertical, and develops angles of deviation of the ship's deck from the true horizontal. The unit may be rotated in train, and has outputs of level and cross-level which may be used as input data to computers used in stabilization systems, or the outputs may be fed to the antenna directly.

**Stable vertical:** A gyroscopic instrument which is similar to the stable element except that it is not rotated in train and has outputs of roll and pitch only.

**Synchro:** A type of wound rotor induction motor used for repeating by remote electrical angular motion both as to speed and total angle. The trade name "Sel-

syn" is often used synonymously with synchro, and is an abbreviation of the term "self-synchronous," and indicates the normal use of the equipment.

*Three-axis stabilization:* This is the same as two-axis stabilization except that provision is made for rotation of the antenna about a true horizontal cross-level axis. More precisely, the level axis and the line of sight are both maintained in a horizontal plane. As in two-axis stabilization, provision is made for adding the deck-tilt correction. Rotation occurs about three axes; namely, the level axis, the cross-level axis, and the deck train axis.

*Tilt:* The angle which the reflector makes with the horizontal.

*Train angle of the target as observed with stabilized sights:* (For two-axis stabilization.) This is the angle, measured clockwise in the ship's deck as seen from

above, from the forward end of the fore and aft axis of the ship to a plane perpendicular to the deck, through the target. (In three-axis stabilization, this plane is perpendicular to the horizon.)

*Train order:* Training a spinner on a target is generally accomplished by means of a hand crank or motor and a servo system. The voltage sent through the servo system resulting in rotation of the spinner about its own axis is called the train order.

*Two-axis stabilization:* This is the same as line-of-sight stabilization except that provision is made for adding the deck-tilt correction to the train order. By this means the spinner is kept pointed at the target irrespective of the roll and pitch of the vessel or aircraft as long as the true bearing of the target does not change. Rotation occurs about two axes; namely, the level axis and the train axis.



## R.F. GOES UNDERGROUND

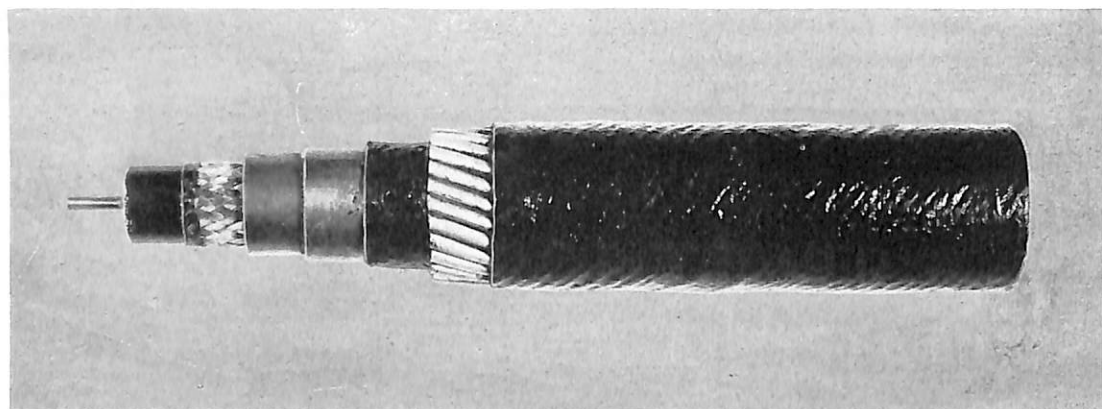

FIGURE 2—Cut away view of the RG-85/U Underground Cable.

By LIEUT. H. F. KANE

and

LIEUT. (jg) R. B. BODENHEIMER

*Installation & Maintenance Division, Bureau of Ships*

At the close of hostilities in the late conflict, the Bureau of Ships Electronics Divisions leaned back with a sigh of satisfaction and took a look at Naval shore radio receiving stations on a long-range basis. During the fast-moving operations of the war years there had been time only to "do the best possible, but quickly—especially quickly!"

Almost the first item to loom into view was transmission lines. For years, Naval shore radio receiving stations had employed long open-wire transmission lines to connect large directional antennas to the receivers. In the meantime, considerable progress had been made in the design of large directional antennas so that now

there are broad-band, high-gain, directional antennas with nearly flat impedance curves. Little had been done, however, to improve the transmission lines used with these antennas.

It was discovered that while directional antennas were being erected to receive signals down a narrow beam, the open-wire line was picking up noise from all directions throughout its length. Theoretically, a balanced open-wire line will not pick up radiations. Experience has shown, however, that it is nearly impossible to keep a line balanced, even when properly terminated.

It was also noticed that the open-wire lines had an irresistible attraction for spiders, birds, snakes, squirrels, and numerous other members of the animal kingdom. In tropical regions, vines just love to drape themselves over poles and lines. In the Arctic, icicles would

much rather hang on transmission lines than on eaves, and they found it's far more fun to break insulators than to clog down spouts. Furthermore, during rainy, foggy, and sleety weather the impedance of the lines was found to vary all over the range.

So the directivity of the antennas was first wide, then narrow, seldom constant. The lines required an excessive amount of maintenance for the results achieved. They were unwieldy, unsightly and vulnerable to sabotage and vandalism. Their erection required large crews and the shipment of materials required large cargo space. If it became necessary to move the station, the lines were not completely salvable. It was readily apparent that a new type of transmission line was required.

A survey of the transmission line field revealed that either a gas-filled or a solid dielectric coaxial line was the logical successor to the open-wire line. A comparison test between the three types of lines was conducted with the results shown in figure 1.

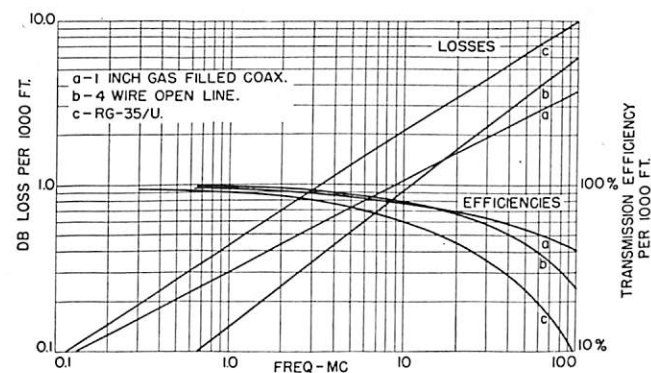

FIGURE 1—Comparative results of tests on three broad types of transmission lines.

At first glance the gas-filled lines appear the most promising of the lot. However, all factors cannot be shown in the graph. Gas-filled coaxial lines require considerable maintenance and are not rugged enough to stand the varied conditions of service required of Navy transmission lines. Further, difficulty has been experienced in the field with poor contact at joints which requires that they be allowed to slip to care for expansion and contraction of line during temperature changes. These poor contacts were noisy, and caused undesirable discontinuities that in many cases were difficult to locate and correct. Although the solid dielectric cable had greater loss than either of the others, it was quieter. The conclusion was reached that the reduction of noise more than counterbalanced the reduction of signal suffered in a solid-dielectric line of reasonable length. The sensitive modern receivers would do the rest.

A look at the various cables on a physical basis dis-

closed that coaxial cable is unaffected by many external uncontrollable factors. Hazards of fire, attack, and vandalism could be greatly reduced if a suitable cable, capable of burial, could be found. Adequate design could reduce maintenance by 95%. A transmission line on a reel would require less cargo space when shipped, a shorter time to install, and would lend itself to complete salvage.

At first glance, the open-wire line would appear to be less expensive than the solid dielectric coaxial line. When the man hours of labor required to rig lines, set poles and fabricate harness for the open-wire lines are added to the cost of materials, however, the sum will exceed the cost of material and installation of solid-dielectric coaxial lines by 20% in average terrain. In many cases, where lines must be run through swampy or rocky terrain, the cost of open-wire lines will exceed the cost of coaxial lines by 50%. This fact gave added impetus to the progress of the problem.

The r-f cable field was canvassed and various samples obtained. No solid-dielectric cable could be found which was completely satisfactory. This is not surprising when it is considered that the requirements included a life expectancy of 20 years while buried anywhere from a tropical tidal marsh to a frozen Arctic tundra.

The Electronics Divisions of the Bureau of Ships began preliminary research to develop the ideal solid-dielectric coaxial transmission line for the Navy's purposes. It was found that RG-35/U cable was quite satisfactory electrically. The problem was thus reduced to one of providing RG-35/U cable with a protective shield which would keep it secure while buried for 20 years against moisture, heat, cold, pressure, soil chemicals, gophers, insects and other detrimental agents. The cable must be reasonably flexible, capable of salvage, require no preventive maintenance and be economically suitable. Borrowing from submarine cable experience, the old standbys of lead, armor, and impregnated jute were selected as protectors.

RG-35/U Cable was covered with a 1/16-inch lead jacket, a 70-pound waterproof jute serve, a double-galvanized, No. 10 BWG steel-wire armor wrap and a 16/3 impregnated-jute serve with whitewash finish. The resulting cable was designated type RG-85/U. See figure 2.

An installation was made with lines connected to large directional antennas in a tropical tidal marsh and is still going strong after two years. The first result obtained was a 4-db reduction in the system noise level due to the exclusion of locally generated noise previously picked up by the open-wire lines. Considerable transmitter power would have been required to increase the signal-to-noise ratio 4 db with the open-wire lines connected to the receivers. The directivity of the antennas was improved by the more

constant match achieved, and maintenance costs of the line to date have been zero. Further installations are being made at many Navy stations situated in the stretch from the equator to the Arctic. Reports from activities receiving the new cable are uniformly enthusiastic over the increased efficiency of reception afforded by their buried transmission lines.

The Bureau of Ships plans to eventually convert all transmission lines used with large directional radio receiving antennas to the solid-dielectric coaxial type wherever feasible.

Meanwhile, efforts to further improve transmission lines are continuing. The search is on to find a suitable moisture barrier, to act as a self-sealer and thus prevent the creeping of moisture along the outer braid conductor of a flexible coaxial cable when the lead jacket is ruptured. It is hoped that the plastics industry will eventually produce a suitable fire-resistant replacement for the outer jute serve now employed over the RG-85/U cable. The requirements for this covering are stringent. It must withstand the effects of sunlight, salt water, soil acids, age and wide temperature variations either singly or in combination.

### SPLICING AND TERMINATING

Development of the above cable posed further problems. Splicing and terminating an r-f cable employing an outer submarine cable covering had never been attempted to the knowledge of the Navy. Basic development of means for doing this was based on normal r-f cable techniques on the one hand, and submarine cable practice on the other. These techniques were combined and improved to fit the far more difficult task of properly splicing and terminating the RG-85/U cable. The splice and termination had to maintain constant impedance, and at the same time be gas-tight and possess physical strength equal to the outer cable protection. Further, it was necessary to train men in the techniques of this difficult splicing and terminating task.



Type of Approach	Last Month	To Date
Practice Landings	8801	142053
Landings Under Instrument Conditions	298	6377



A minimum of eight man hours is allowed to perform each splice in the field by an experienced cable splicer. To assist in performing the splice a cable splicing kit, Navy type 10646, is provided which contains all the accessories and materials required for splicing the cable in the field. A completed splice up to and including the cable protector is shown in figure 3. Over this is added a jute or marlin wrapping impregnated in okonite or similar compound to complete the splice. Once completed in the prescribed manner, the splice provides the same physical strength as the actual cable and affords a gas-tight barrier. It is expected to endure a minimum of 15 years service. No perceptible impedance variation has been detected to date in the present cable installations.

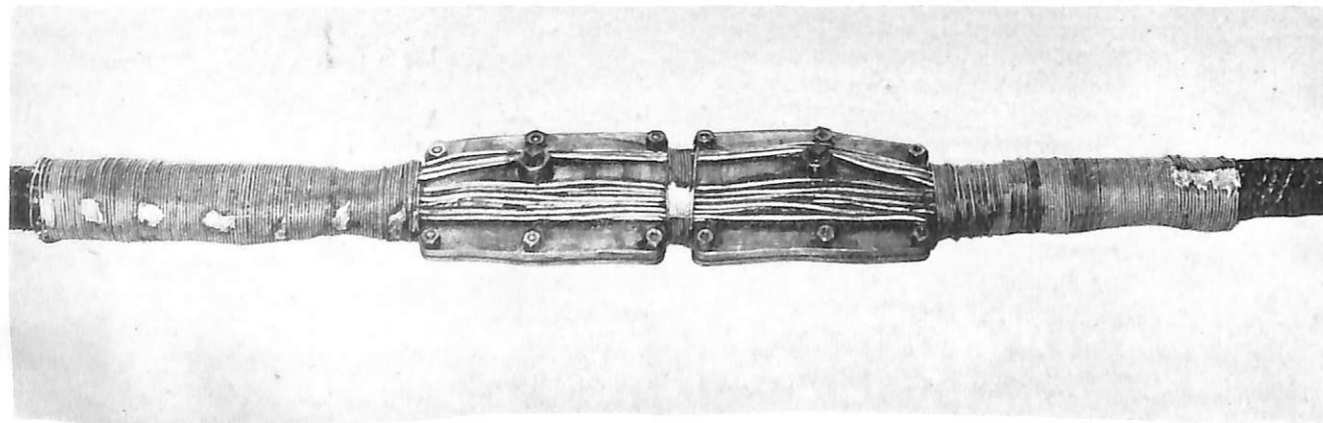

FIGURE 3—Splice complete, with armor wire seized.

The connector adaptor, Navy type 491652, is shown in figure 4. It is utilized to terminate the RG-85/U cable at the receiver-building end of the cable. To this termination, smaller r-f cables possessing far more flexibility are connected for distribution of signal energy to the various receivers within the receiver building.

The end seal, Navy type 491567 is the same as the connector adaptor shown in figure 4 except that the parts contained within dotted line in figure are substituted by a styramic cap to afford rigidity for the center conductor and a terminal point for connecting to an antenna matching transformer or similar device. The transformer case is made gas tight and is provided with a "threaded boss" for securing the end seal to the transformer case. A special circular gasket, seated

between the boss and end seal, maintains the required gas-tight integrity.

Since the obstacles presented in the design of the above cable and associated fittings have been overcome and the cable brought into practical use, the Navy is now considering other similar developments in an endeavor to provide the ultimate in rapid communications. Among these is the design of a dual, air dielectric, balanced r-f cable having physical characteristics similar to the RG-85/U but with less electrical attenuation. Only through the continued diligent efforts on the part of the Navy and manufacturers is it possible to realize the achievement and perfection of facilities that are required for today's and tomorrow's communications, the nerves of the Nation and the Navy.

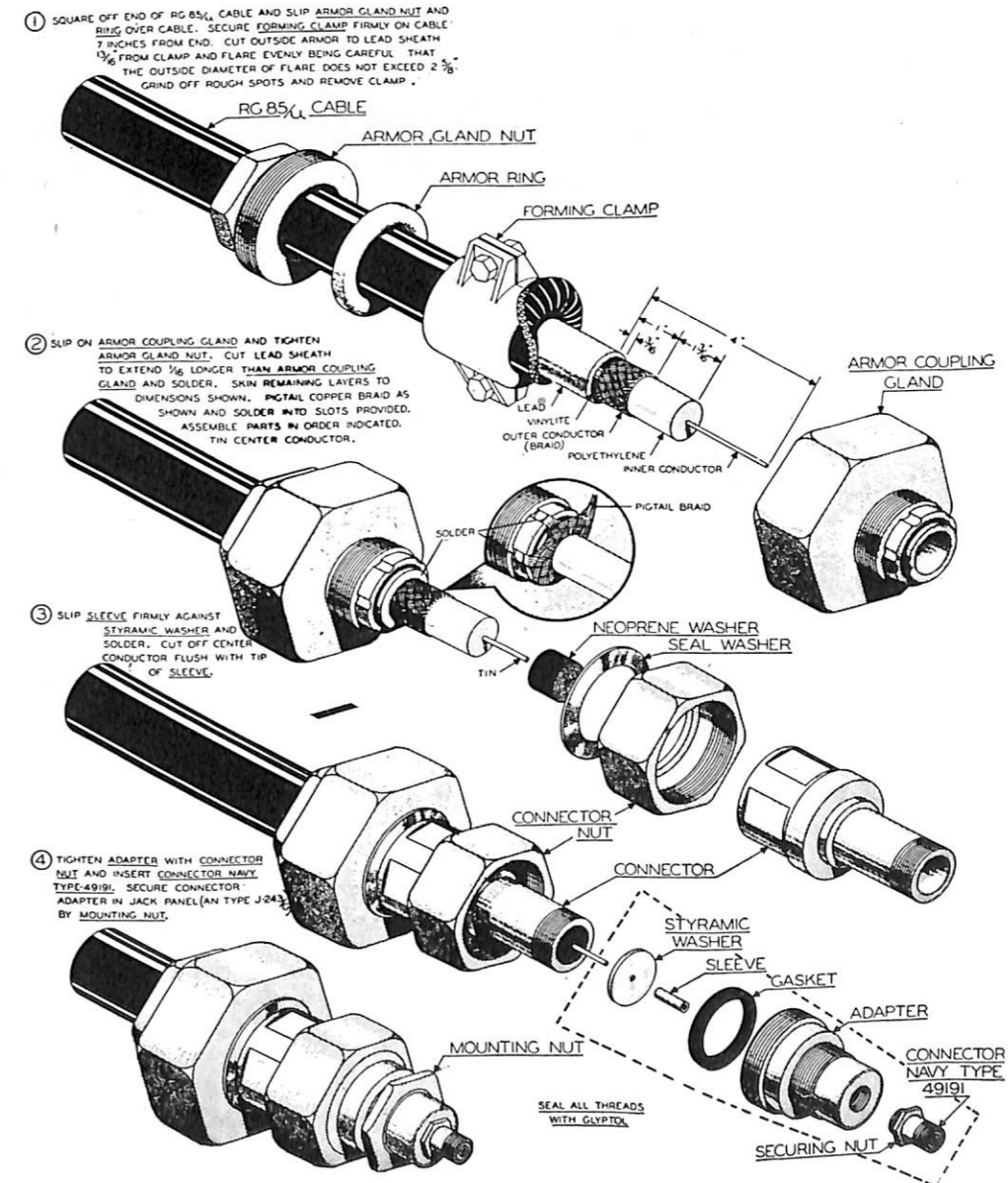

FIGURE 4—Installation of connector-adaptor Navy Type CIA-491652 on cable AN Type RG-85/U.



## NAVAL RAILROAD COMMUNICATION IN FIFTH NAVAL DISTRICT

By LT. COMDR. L. C. HARLOW, USN

"Yoke 13. This is Yoke Dog. Over."

"Yoke Dog. This is Yoke 13. Over."

"Yoke 13. Proceed to Building 276. Pick up KCS box 114164 and deliver to receiving track west end. Over."

"Roger. Yoke 13 out."

"Yoke Dog out."

The above is one of the many messages that are constantly exchanged between the dispatcher and the conductors of various yard switching crews at the Norfolk Naval Shipyard. This is also similar to that heard at the Naval Ammunition Depot, St. Juliens Creek, Va., and the Naval Mine Depot, Yorktown, Virginia, where the installation of two-way radio communication equipment has materially speeded up the switching operations.

Although officially designated "Industrial Control," it is known more generally as "Locomotive Control." The basic installation consists of a fixed 50-watt transmitter

Leadingman Dispatcher W. E. Gay issues an order to one of the yard locomotives from his office in the Transportation Shop (Shop 02). In the rear is shown the 50-watt Link transmitter.

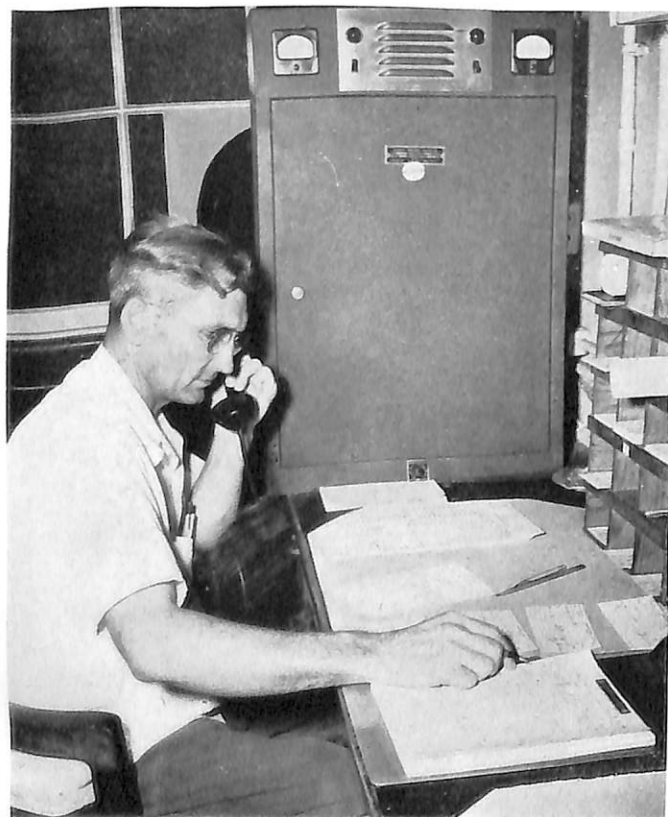

OPPOSITE PAGE . . . Conductor, C. E. Jordan receives an order in the locomotive cab while Engineer, E. J. Sallabe prepares for the next switching move.

controlled from the dispatcher's office, and one mobile transmitter-receiver in each locomotive. This enables all switching crews to be in constant touch with each other and with the dispatcher.

Prior to the installation of this system at the Norfolk Naval Shipyard in 1944, orders were relayed to switching crews by special messengers who had to drive around the yard until they found the right crew, and then deliver the message. The installation of the two-way

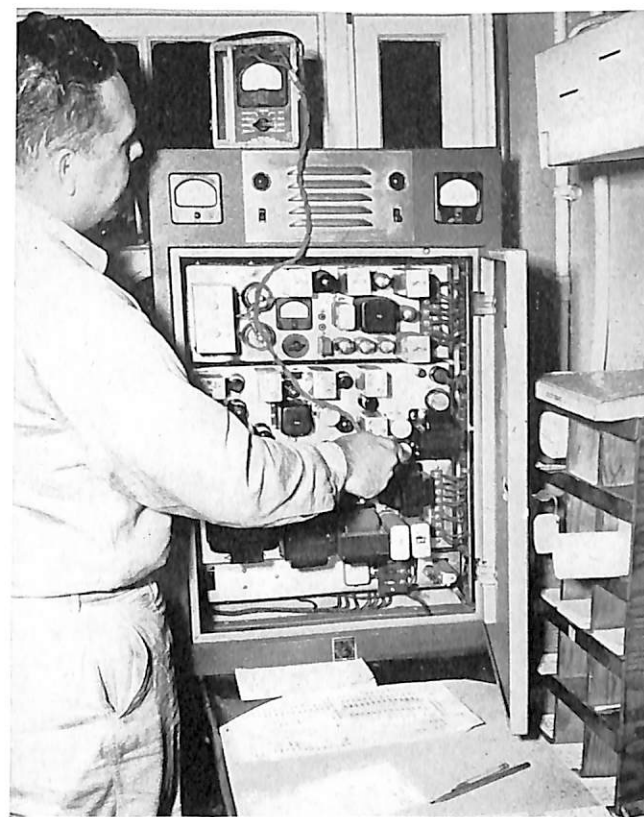

W. C. Cousins of the Electronics Shop (Shop 67) making minor adjustment to a 50-watt Link transmitter in the Dispatcher's Office.

communication released two drivers and two trucks, and made all crews available for assignment all of the time. It also prevents long waits at separated passing tracks, each crew waiting for the other to arrive.

When a locomotive transmitter or receiver needs repair, it comes to the Electronics Shop where the equipment is either repaired on the spot or else another equipment is substituted. The repairs and adjustments are performed by Electronics Shop (Shop 67) personnel.

As a result of the Navy's experiences in using radio for locomotive control, a number of railroads are now installing two-way radio for the handling of trains in the yards and on the road.

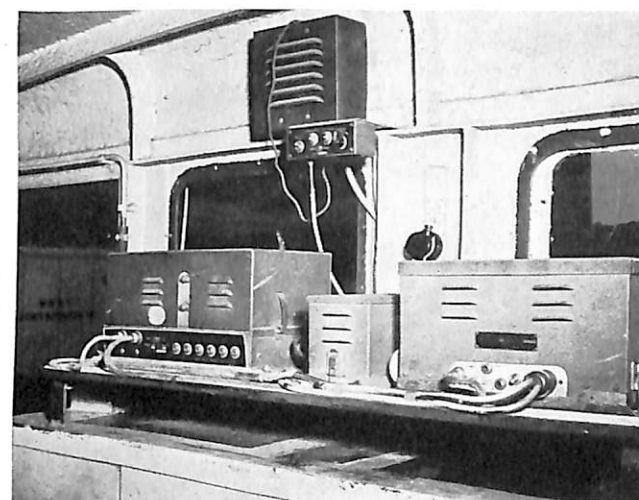

Radio transmitter and receiver mounted in locomotive cab.

★ ★ ★ ★ THE AUTHOR ★ ★ ★ ★



Lt. Comdr. Lester C. Harlow

Lt. Comdr. Lester C. Harlow was born near Nicherson, Kansas on 11 October 1912. He received his elementary and high school education from schools in Canada and Arkansas. He later entered Brown University at Siloam Springs, Arkansas, and received a B.S. degree in electrical engineering from there in 1939.

Lt. Comdr. Harlow enlisted in the Naval Reserve in 1933, and served in various rates until he was commissioned Ensign in 1941. His active duty began in 1940. He was in the first group of officers trained in radar and is a graduate of the Radio Materiel School. He transferred to the United States Navy in 1946. Some of his former duty stations include INSMAT, Schenectady, Mare Island Naval Shipyard and the Bureau of Ships. He is now Assistant for Shore, Electronics at the Norfolk Naval Shipyard.

# PRINCIPLES OF ELECTROMAGNETISM

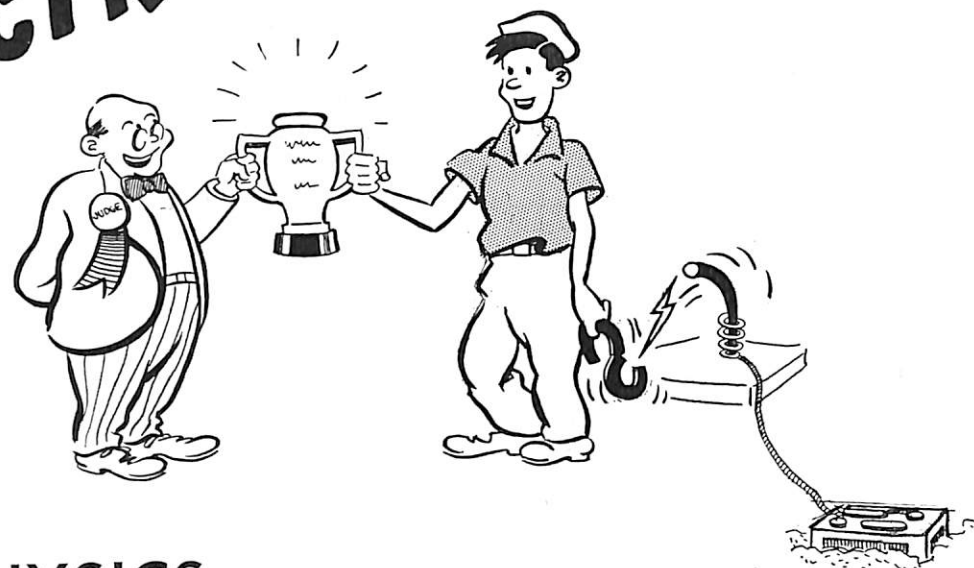

## BASIC PHYSICS PART 13

Electromagnetism is the study of the magnetic phenomena associated with an electric current, or basically, electrons in motion. In previous assignments electrons at rest were associated with electrostatic phenomena. Magnetism and magnetic effects were studied in connection with permanent magnets only.

Before establishing a relationship between electric currents and the attendant magnetic effects, it will be helpful to review the basic principles of magnets and the physical law governing their behavior. Hence the various concepts of magnetism are briefly restated here. They are:

- 1—Magnetic fields are imagined as composed of lines of force, their direction being that in which a free N-pole would move if free to do so. The direction of the lines of force are further taken to be from south to north within a magnet or a magnetic material and from north to south in the magnetic field external to the magnet.
- 2—A magnetic field tends to conform itself to maintain a maximum flux density, even to the extent of field distortion.

- 3—The lines comprising the magnetic field never cross one another.
- 4—If lines of force are parallel and in the same direction, they act as if there were a force of repulsion; conversely, if they are parallel and oppositely directed, they act as if there were a force of attraction present.
- 5—Magnetic field intensity varies inversely at the square of the distance between the points of measurement or observation.

*The discovery of electromagnetic effects.* In 1820, Oersted, after whom the unit of magnetic field intensity was named, discovered, quite by accident, that when a compass was brought into the vicinity of a wire carrying an electric current, it exhibited all the effects of a magnetic influence. He further noted, through a series of experiments with a small compass, that a magnetic field was always associated with the flow of current, or movement of electrons in a conductor.

The magnetic field was indicated to be circular and concentric with the wire, the direction of the field being

counter-clockwise when looking in the direction of the current flow. This is shown in figure 1. The compasses indicate the direction of the magnetic lines of force encircling the wire, but note that the compass needles change direction depending upon whether they are above or below the wire, but they always point in the direction of the lines of force.

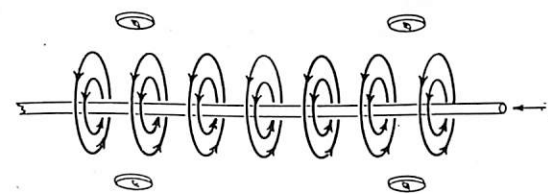

FIGURE 1—Lines of force about a conductor carrying an electric current.

Figure 1 shows four positions of the compass along the direction of the wire conductor. The compass positions provide evidence of the existence of a magnetic field everywhere along the length of the conductor. It is reasonable to assume, therefore, that the magnetic field not only encircles the conductor in a tube-like fashion, but extends outward from the conductor indefinitely with the greatest intensity nearest the wire and decreasing as the distance from the wire becomes greater.

This assumption is clearly illustrated in figure 2, showing a straight wire that has been passed perpendicularly through the center of a sheet of heavy paper upon which iron filings have been sprinkled. When a current is flowing through the wire, and the paper tapped gently, the iron filings, under the influence of the magnetic field about the wire, arrange themselves into concentric circles, indicative of the lines of force comprising the magnetic field which is produced by the flow of current in the wire. In laboratory experiments, approximately 100 amperes of current are required to obtain distinct formations.

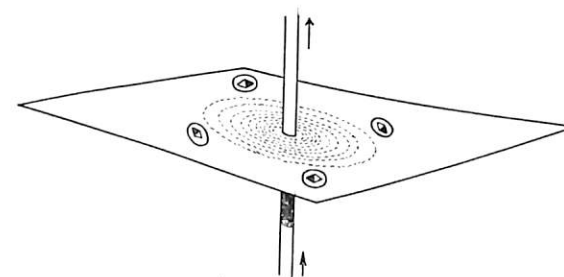

FIGURE 2—The use of iron filings to indicate the presence of the magnetic field about a current-carrying conductor.

*Magnetic fields about parallel conductors.* The magnetic effects produced by the flow of the current in parallel conductors may be studied in the same manner,

using a compass or iron filings to indicate graphically the field directions.

Figure 3A shows the direction of the magnetic field produced by two parallel conductors in which electric currents flow in the same direction. The field about each wire is counter-clockwise when the current is away from the observer. This is important to remember, since this visual concept will be found useful on many occasions. As the distance from the conductor becomes greater, more of the lines of force about one conductor oppose those of the other conductor in the region between the conductors. Since lines of force cannot cross, where this coincidence occurs and the lines are oppositely directed, cancellation results, and a distorted loop is formed which encloses both conductors, causing a composite magnetic field about the two conductors. This is an example of the property of a magnetic field which tends to conform itself to maintain a maximum flux. The resultant magnetic field of two conductors in which the currents are in the same direction is the total sum of the individual fields. This will be further developed later.

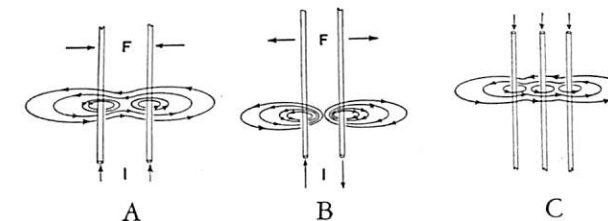

FIGURE 3—A. Magnetic field direction and resultant force existing between two parallel conductors when the current is in the same direction. B. Magnetic field direction and resultant force existing between two parallel conductors when the current is in opposite directions. C. Field configuration about three parallel conductors through which electric current is passing in the same direction.

In the case of two parallel conductors in which the currents flow in opposite directions, magnetic fields of opposite directions will be produced as shown in figure 3B. In the left conductor, the direction of the field is counter-clockwise and in the right conductor, clockwise. In the region between the conductors, the lines of force have the same direction, are parallel, and do not cancel or cross each other. This results in crowding of the lines of force and because of this field concentration, a repelling force is exerted tending to separate the two wires.

Figure 3C, you will note, is merely a multiple version of figure 3A. A number of parallel conductors in the same plane are shown, whose currents are flowing in the same direction. The resultant magnetic field is produced by the combining of the individual fields into a larger field that encompasses all the wires. If the direc-

tion of the electric current is reversed simultaneously in all of the conductors, the direction of the magnetic field will also reverse, but the magnitude will remain the same.

In modern high-current-capacity power systems, the effects of the phenomena described above have to be taken into consideration in the design of power equipment. For example, the magnetic forces between conductors due to excessive currents during overload conditions have caused huge bus-bars to be wrenched from their clamps and fastenings. Transformers, also, have been wrecked internally and pulled out of place because of the tremendous forces of attraction or repulsion that were produced by excessive currents in the conductors.

*Fundamental expression of magnetic field intensity.* In the early 1820's, Ampere, the noted French physicist, performed a series of experiments with current-carrying wires. His objective was to derive from the experiments a fundamental expression of the relationship between electric current flow and the magnetic effects produced.

The relationship, as he worked it out, can be logically followed by reference to figure 4A, which shows a current-carrying-wire in the plane of the page. Imagine the conductor as being composed of an infinite number of segments, each designated  $\Delta s$ , and the entire magnetic field about the wire as being produced by the passage of current through successive segments that comprise the wire.

Ampere followed the theory that each segment  $\Delta s$  contributed some part of the magnetic field intensity at any point in the field. Through his experiment, he found that the field intensity contributed to point  $P$ , for example, from an element  $\Delta s$  at any random place along the length of the wire could be expressed as follows:

$$H_p = \frac{I(\sin \theta)}{r^2} \text{ oersteds.}$$

This expresses the field intensity in oersteds at point  $P$ . The current  $I$  is in abamperes. The angle  $\theta$  is the angle between the direction of the current flow and the direction of point  $P$  from the segment in question. The quantity  $r$  is the perpendicular distance between point  $P$  and the conductor and is in terms of centimeters.

A careful examination of figure 4B, and the general expression of the field intensity contribution of each element of the wire should suggest two facts: As the current  $I$  is increased, the field intensity at point  $P$  will also increase, and as segments closer to point  $P$  are considered, the contributions to the field intensity at  $P$  will also increase. Due to the fact that the field is concentric with the wire, it is plain that the field intensity due to any segment,  $\Delta s$ , is maximum at right angles to the wire. Consequently the contributions of segments at right angles to point  $P$  will be greatest, while those far removed from point  $P$  will contribute but little.

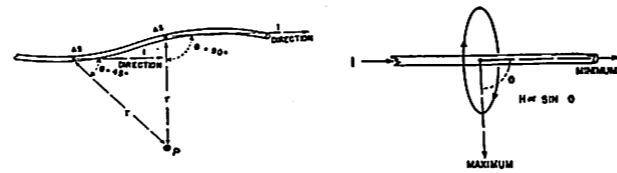

FIGURE 4—The contributions of field intensity at point  $P$  by segments  $\Delta s$  shown as a function of the sine of angle  $\theta$ .

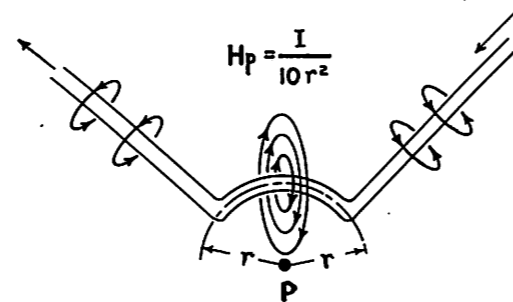

FIGURE 5—Magnetic field produced by an arc.

*Derivation of unit current based on electromagnetic effect.* Unit current in the electromagnetic system of units may be defined in terms of the field intensity that is produced when current is passed through a wire with the special shape shown in figure 5. An arc of 1 centimeter length and of a radius 1 centimeter is used because, by geometry, it is known that any point on an arc is equidistant and perpendicular to the center of the arc. This particular configuration is used because the maximum field intensity produced by any segment comprising the arc occurs perpendicular to the segment. Therefore, the maximum field intensity from each segment will coincide at the center  $P$ . The connecting wires to each end of the arc branch off at right angles so that their fields have no effect at point  $P$ .

When the arc and radius are both made equal to 1 cm, the current that will produce a field intensity of one oersted at point  $P$  becomes unit current in the electromagnetic system of units. This is the abampere named in honor of Ampere, who performed the first quantitative experiments in establishing the relationship between electricity and magnetism.

The abampere is a relatively large unit of current for practical use. The practical ampere is one-tenth abampere and is more adaptable to practical use.

*Magnetic effects of a single-turn loop.* The field in-

tensity at the center of an arc such as that used to obtain a definition of unit current is stated:

$$H = \frac{I \times (\text{arc length})}{\text{radius}^2} \text{ oersted,}$$

where the current  $I$  is expressed in abamperes, and the dimensions of the arc and the radius are made equal and expressed in centimeters. This expression represents the summation of all contributions to the field intensity at the center of the arc by the elements composing the arc.

If an arc is extended to form a complete circular loop having a radius of  $r$  centimeters (see figure 6), the sum of all the elements that comprise the wire turn is, in fact, the circumference of a circle, or equal to  $2\pi r$ . When measuring current in practical amperes, the fundamental formula, which was given in terms of electromagnetic units, must be divided by 10. Therefore the field intensity at the center of the loop may then be expressed:

$$H = \frac{2\pi r I}{10 r^2} = \frac{2\pi I}{10r} \text{ oersted.}$$

From this relation the practical ampere may be defined as the current which in a coil having 1 turn and a radius of 1 cm. will produce at the center a field intensity of  $\frac{2\pi}{10}$  oersted. Note that when the radius is made unity, it disappears from the equation—a common practice used in deriving any unit in terms of another in the same system.

At this point it should be recalled that electric currents moving in the same direction through parallel conductors produce a cumulative field about all conductors. It is but a simple step to combine this knowledge with the expression for the field intensity at the center of a single-turn loop, and, providing that the turns are so grouped that the entire coil has little axial length compared with its radius, the field intensity at the center of such a flat coil may be expressed as:

$$H = \frac{2\pi N I}{10r} \text{ oersteds.}$$

where  $N$  is the number of turns,  $I$  is current in amperes, and  $r$  is the radius in centimeters. The denominator 10 is necessary to reduce practical amperes to absolute amperes.

Figure 6 shows a wire bent into the shape of a loop. The field produced as a result of current flow possesses all the properties of a small bar magnet. A small compass serves to indicate the direction of magnetism. The effect is the same as if the lines of force through the center of the coil were produced by a bar magnet of the same strength.

It is in this manner that permanent magnets are produced commercially. The specimen to be magnetized is placed along the axis of the coil parallel to the lines of induction. (This applies to magnets of the bar shape.)

The degree of magnetism induced in a specimen is dependent upon several factors, such as the permeability of the magnetic material and the field intensity produced by the current flow in the turns of the coil.

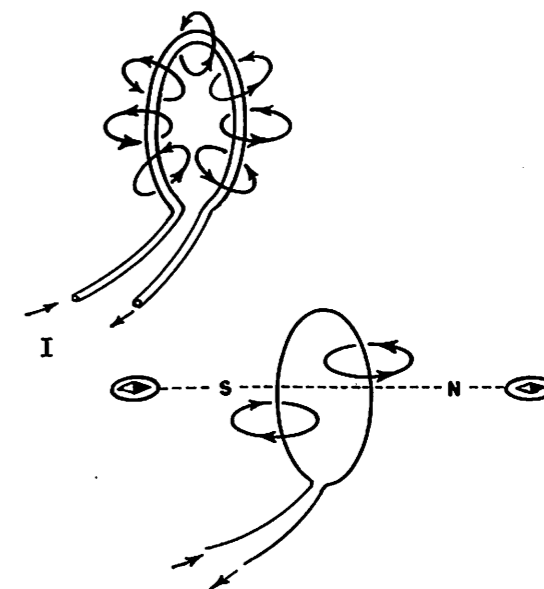

FIGURE 6—Magnetic field of a single turn.

*Biot-Savart Law for a long straight conductor.* The general expression for magnetic field intensity as derived by Ampere was later verified by the French physicists, Biot and Savart, in their quantitative study of the magnetic field produced by an electric current in a long straight wire.

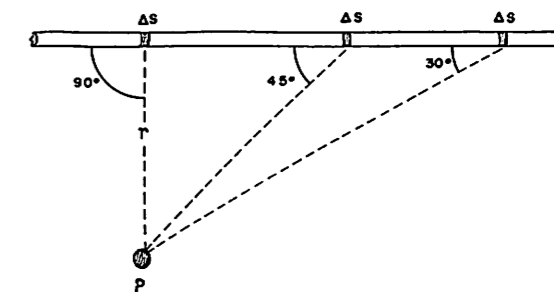

FIGURE 7—Biot-Savart Law.

Figure 7 represents a portion of a wire extending indefinitely in each direction from a point opposite  $P$ . In determining the field intensity at  $P$  in space at a perpendicular distance  $r$  from the wire, the reasoning is followed that each segment  $\Delta s$  along the length of the wire contributed something to the field intensity at  $P$ . It is evident that as successive segments farther from  $P$  are considered, the angle  $\theta$  becomes less than  $90^\circ$ , hence the sine function of the angle  $\theta$  decreases from 1 and approaches zero value at great distances from point  $P$ .

Magnetic field intensity varies as the inverse square of the distance. Therefore, starting from a point on the wire opposite  $P$ , where the separation is  $r$  cm, the square of the separation between  $P$  and segments farther away becomes increasingly large.

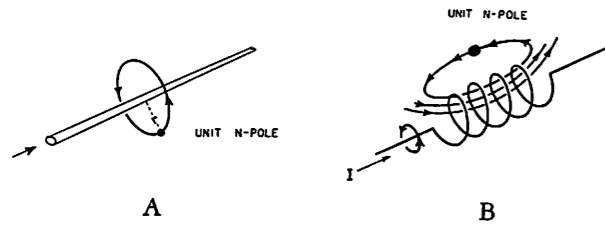

FIGURE 8—A. Motion of a N-pole about a current-carrying conductor. B. Motion of a N-pole in the magnetic field of a solenoid.

Now consider Ampere's fundamental equation from these observations. It is apparent that the numerator decreases in value and the denominator increases in value as successive segments farther and farther away from  $P$  are taken. Since the field intensity at  $P$  is the result of all segments of the wire, both directions must be considered. The summation of magnetic field contributions to point  $P$  from the infinite number of segments that comprise the straight wire is made by calculus and reduces to:

$$H_P = \frac{2 I}{10 r} \text{ oersted,}$$

where  $I$  is the current in amperes and  $r$  is the perpendicular distance from the wire to point  $P$ . Experiments have shown that when the distance from  $P$  is over 40 times the separation  $r$ , the distance can be considered as infinite, since the error is inconsequential (approximately 0.1%).

*Motion of a N-pole in a magnetic field.* The foregoing expression for field intensity at a point in the magnetic field surrounding a straight conductor can be used to calculate the amount of work that must be done to move a unit N-pole once around a closed path at any distance from the conductor. Work is an expenditure of energy; hence, the movement must be in opposition to the force of the field. In figure 8A is shown a long straight conductor through which is passing a current of  $I$  amperes. If a pole of unit strength is to be moved once around the wire in the path indicated at a distance  $r$  cm. from the wire, the work required is:

$$W = \text{Force times distance} = \frac{2 I}{10 r} \times 2\pi r = \frac{4\pi I}{10} \text{ ergs}$$

where the opposing force is the field intensity at  $P$ , and the distance for one complete circular path is  $2\pi r$  cm. Since the radius cancels in obtaining the work required, the work is found to be independent of the path, and would be the same for any closed path around the conductor, whether circular or not. The work remains the same whether the wire is straight or bent in

the form of a loop, so long as the path is completely around the wire causing the magnetic field.

When more than one loop of wire is used, the work required to move a unit N-pole through a coil of  $N$  turns and length  $L$  in the path shown in figure 8B

would be  $\frac{4\pi N I}{10 L}$  ergs to link its path with all the turns.

This holds true only for coils in which the axial length is quite small when compared to the radius of the coil.

*The magnetic field of a solenoid.* An electric conductor wound spirally in the form of a helix about a straight axis is called a solenoid. The solenoid may be considered as consisting of a single layer of many turns where the axial length of the coil is greater than the radius, or of many turns wound in layers to reduce the axial length. Examples are shown in figures 8B and 9.

The relationship of current and magnetic field produced will be noted to be the same in either case, but with the layer-wound solenoid it is possible to obtain a greater concentration of lines of force with respect to the physical dimensions.

When the length of a coil becomes appreciable with respect to the radius of the coil,  $\frac{4\pi N I}{10 L}$  expresses only the field intensity at the center of the solenoid, and only along the axis. The treatment of the field intensity contributions carried out in calculations for a straight conductor may also be applied to a solenoid, and for practical purposes when the ratio of length to radius becomes greater than 40:1, the solenoid is considered as infinite in length. The experiments have proven that the field intensity at the center of a solenoid (ratio greater than 40:1 and with a straight axis) is equal to:

$$H = \frac{4\pi N I}{10 L} \text{ oersteds.}$$

where  $N$  is the number of turns and  $I$  is the current in amperes.

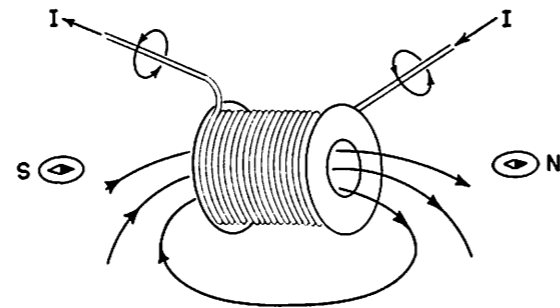

FIGURE 9—Magnetic field of a layer-wound type solenoid.  
Work = Force times distance.

Therefore, the work to move a unit N-pole along the axis is equal to  $HL$ , where  $H$  is the field intensity at

the center of the coil and  $L$  is the distance or length of the axis along which the N-pole is moved. Thus:

$$W = H L \text{ ergs.}$$

and for unit distance:

$$W = \frac{4\pi N I}{10} \text{ ergs.}$$

By equating the two values of work:

$$HL = 0.4\pi N I$$

$$HL = \frac{0.4\pi N I}{L} \text{ oersted.}$$

where  $N$  is the total number of turns,  $I$  is the current in amperes, and  $L$  is the length of the axis in cm.

This equation expresses the force in dynes per unit pole that is exerted along the axis of a solenoid. It is useful in connection with the explanation of the simple plunger-type of electromagnet shown in figure 10A.

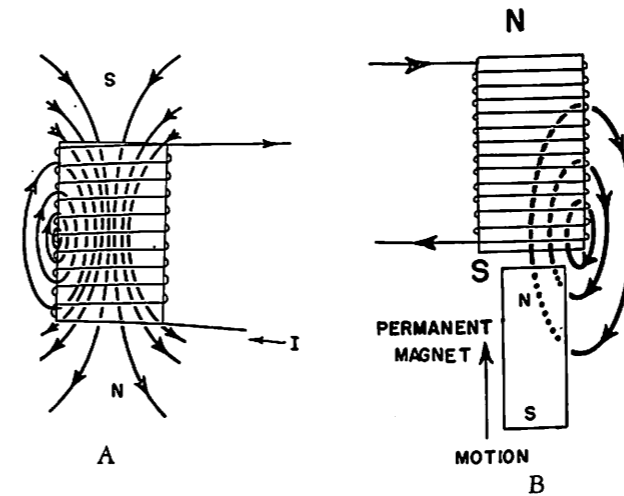

FIGURE 10—A. Magnetic field of a simple solenoid electromagnet. B. Motion of a permanent magnet under the influence of an electromagnet.

The field produced as a result of current flow is shown by lines whose direction conforms with our concepts of magnetism. The magnetic polarity of the solenoid is in turn determined by the direction of the lines of force. As shown in figure 10A, the top of the solenoid will exhibit the same properties as the north pole of a permanent bar-magnet; the bottom of the coil will be the south pole.

In figure 10B a bar magnet is placed in the field at the bottom of the solenoid, with the N-pole of the magnet toward the coil. The lines of force about the solenoid in passing through the tip of the bar magnet exert a force of  $0.4\pi NI$  dynes per unit pole and hence the magnet is forced into the core of the solenoid. When the current in the turns of the solenoid are reversed, the magnetic field will also reverse, as will the magnetic polarity. However, the magnetism of the permanent magnet remains the same, with the N-pole now in the field of the N-pole produced by the solenoid. The direc-

tion of the lines of force now cause the bar magnet to be repelled from the core of the solenoid.

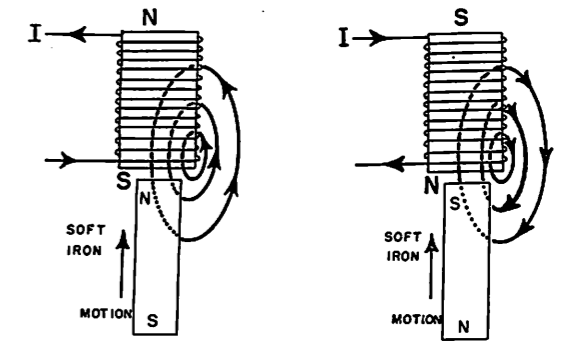

FIGURE 11—Action of a soft-iron rod under the influence of changing magnetic fields in a simple solenoid.

In figure 11A, the bar magnet has been replaced with a soft iron plunger. When the solenoid is energized with an electric current, the lines of force induce magnetism in the soft iron plunger, an S-pole at the point of entrance and an N-pole where the lines of force leave the iron. The magnetized plunger will then be moved into the solenoid in the same manner as the bar magnet. But, if the direction of the current in the solenoid is reversed, a different condition will exist, because the soft iron retains little of the induced magnetism when the lines of force are removed. The reversed field is now directed downwards as shown in figure 11B. The magnetic polarity of the solenoid has now changed but it will be noted that the lines of force induce the same magnetic poles in the iron plunger, therefore the plunger is still attracted by the solenoid because of the proximity of unlike poles, hence the pull remains the same. See figure 11B.

When the iron plunger is first brought into the vicinity of the solenoid, the path of the lines of force is mostly air, whose reluctance is much greater than that of soft iron. The pull is weak because the field is consequently weak. As the plunger enters the core of the solenoid, the reluctance of the magnetic path is decreased and more lines of force are accommodated by the iron; the pull increases because both the magnetic field and the induced poles become stronger.

After the tip of the plunger passes the center of the solenoid where the field intensity is maximum, the reluctance of the magnetic circuit continues to decrease and the strengths of the magnetic field and the induced poles to increase, but the pull actually starts to reduce because the induced poles of the plunger produced by the solenoid. The pull exerted by the plunger becomes zero when the above forces reach equilibrium, the plunger is entirely within the solenoid and the reluctance of the magnetic path is a minimum.

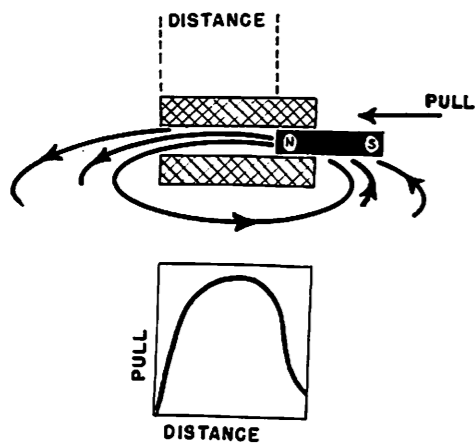

FIGURE 12—Pull exerted by an electromagnet versus plunger position.

A graph of the pull on the plunger versus the length of the solenoid is shown in figure 12. It will be noted that for a considerable portion of the distance traveled, the pull is nearly constant at the maximum value. The force exerted by the solenoid decreases as the end of the plunger passes the center of the solenoid a short distance for reasons previously given.

It is general practice to stop the travel of the plunger at some point between the center and the end of the solenoid to obtain the maximum pull when in the energized state. This type is called a "stopped" electromagnet. The stop is usually in the form of a plug made of magnetic material that fills the desired portion of the core. Electromagnets of this type are used in magnetic brakes, circuit overload and starting contactors and wherever strong positive contact is required.

**Lifting or holding magnets.** The law of the magnetic circuit—that the magnetic field tends to form itself to permit the maximum flux—may be stated in another definition. The physical force exerted on any magnetic material in a magnetic field tends to move the material in such a direction as to reduce the reluctance of the magnetic circuit.

Commercial magnets of the lifting or holding type make use of this principle; for example, magnetic track brakes, and electromagnets used for lifting steel or iron scrap.

Lifting and holding magnets are generally of the horseshoe or of the annular ring shape shown in figure 13. The iron, steel or magnetic material to be lifted merely furnishes the low reluctance flux path across the magnet face. The pull exerted by the magnet increases as the separating distance between the magnet and the material becomes less. Therefore, if the shape of the magnetic material is irregular, less weight can be lifted than if the contact surface were flat.

A 2250-lb annular ring electromagnet can lift only a 2000-lb iron ball used for wrecking purposes, but

steel slabs up to 10 ton may be picked up by it. Iron and steel scrap is limited to 500 lbs due to the smaller contact surfaces presented. The pull may be determined very closely by Maxwell's formula:

$$\text{Pull in dynes} = \frac{B^2 A}{8 \pi}$$

where  $B$  is the flux density in lines per square cm., and  $A$  is the total pole face area in cm.<sup>2</sup>

$$\begin{aligned} \text{Note: } 981 \text{ dynes} &= 1 \text{ gram} \\ 1000 \text{ grams} &= 2.205 \text{ lbs.} \end{aligned}$$

**Magnetic circuit calculations.** The relation of flux, magneto-motive force, and the reluctance of a magnetic circuit is identical with the relationship of current, electromotive force, and resistance encountered in electric circuit calculations. When magnetic circuit calculations are attempted, difficulties are encountered because of the many leakage paths afforded by air, and the variations of the permeability with different circuit conditions.

For the magnetic circuit:

$$\text{Total flux} = \frac{\text{Magneto-motive force}}{\text{Reluctance}}$$

where the total flux is expressed in maxwells, the m.m.f. =  $0.4\pi NI$  and the reluctance =  $\frac{L}{A\mu}$ .

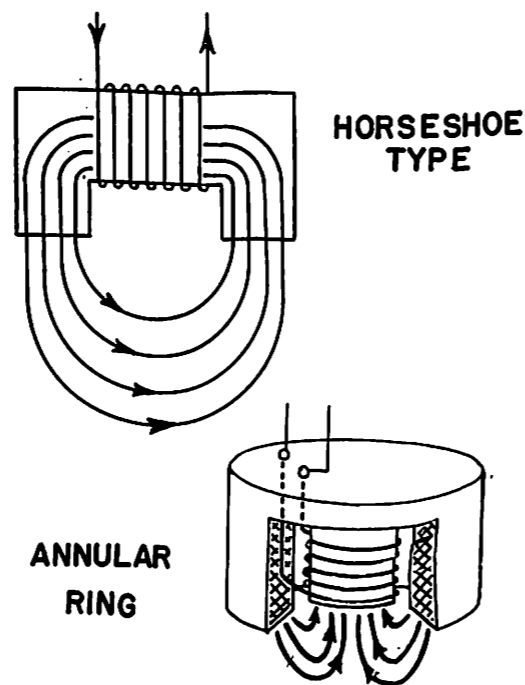

FIGURE 13—Horseshoe and annular-ring type electromagnets.

Since magnetic circuits consist of magnetic materials as well as air, it is more convenient to calculate in terms of flux density desired and design toward the m.m.f that

will produce this flux density plus losses due to leakage in air paths.

Flux density is the number of lines per unit area, therefore the above relationship may be stated:

$$BA = \frac{0.4\pi NI}{L A \mu}$$

In simplifying, the area cancels and the relation:

$$B = \frac{0.4\pi NI \mu}{L}$$

is obtained. Recalling that in air  $\mu$  is unity, it is found that this is the same relationship between the field intensity, along the axis of a solenoid, and the field produced by the solenoid. The magneto-motive force is defined as that force which tends to maintain flux in a magnetic circuit.

$$M.m.f = \frac{R L}{\mu}$$

where m.m.f equals  $0.4\pi NI$ .

The permeability of a magnetic material varies with different flux values and upon the quality and type of material. This is made easy by the magnetization curves plotted by the manufacturers of magnetic materials; these show the permeability at any value of flux density from zero to magnetic saturation of the material.

Further simplification is provided by commercial concerns by addition of curves in terms of flux versus ampere-turns, which are based on the relation given above.

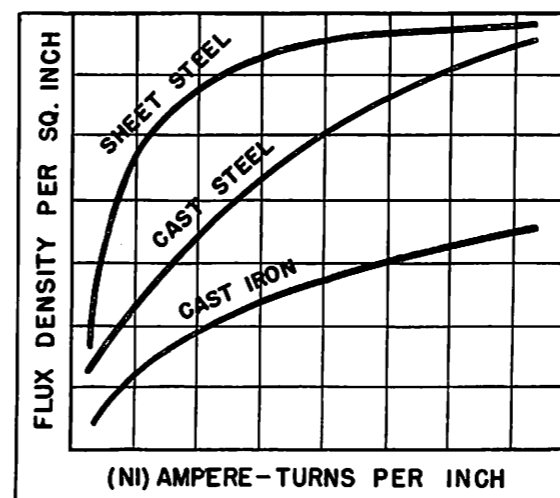

FIGURE 14—Relative magnetization curves for commonly used magnetic materials.

Magnetization curves for iron and steel representative of those used in the manufacture of electrical machinery are shown in figure 14. In working out designs for manufactured products based on these curves it is com-

mon practice to avoid any plan that calls for operation near the saturation point of the material. For as the saturation point is approached the ratio of magnetizing force to flux density increases such that it is impracticable.

It is usually required to determine the ampere-turns ( $NI$ ) necessary to produce a uniform flux in an air-gap between two parallel planes having areas of  $A$  cm.<sup>2</sup>, and space a distance of  $L$  cm, then, from the previous

$$\begin{aligned} \text{formula, } m.m.f. &= \frac{BL}{\mu} = 0.4\pi NI \\ NI &= \frac{1}{0.4\pi} \times \frac{(BL)}{1} \end{aligned}$$

$NI = \text{approximately } 0.8 BL$  (since  $\mu = 1$  in air)

For example, to determine the ampere-turns to produce a uniform flux of 2,000,000 maxwells between two parallel faces of area 500 square cm, and separated 0.5 cm:

$$B = \frac{\text{Total flux}}{\text{area}} = \frac{2,000,000}{500} = 4,000 \text{ gauss}$$

$$NI = 0.8 \times 4,000 \times 0.5 = 1600 \text{ ampere-turns.}$$

Ampere-turns is a product; therefore, if 1600 ampere-turns are required it may be obtained by using a solenoid of 1600 turns and a current of 1 ampere, 16,000 turns at 0.1 amp or 160 turns and 10 amperes, whichever is more convenient to the design with regard to economy.

For the various irons and steels used in the manufacture of electrical machinery and transformers, calculations are usually based on an operating flux density of 10,000 gauss.

**The hysteresis cycle.** If an iron or other magnetic sample be placed inside a solenoid similar to that in figure 10A, and the current through the wire gradually increased from a zero value, the magnetic field will also increase, and a corresponding increase of magnetization in the sample will occur. As the field is increased to greater values of flux density, a condition of saturation is reached in the material when all possible magnetic domains within the material are aligned with the lines of force from the solenoid. This saturated condition indicates the maximum flux density that can exist in the particular sample. The relationship between magnetizing force and flux density (induction) is called the normal saturation or magnetization curve. Such a curve has already been discussed.

However, as the magnetizing force is decreased from a condition of saturation in the material, the flux density will not decrease at the same rate. Instead of decreasing at the same rate as the increase, there is a definite time lag of the flux density with respect to the magnetizing force. This lag has been given the name hysteresis, implying a time lag.

The phenomenon of hysteresis may be easily understood by recalling to mind the theory of magnetism and



the ferromagnetic properties of magnetic materials. Under the influence of an inducing magnetic field, magnetic regions in a ferromagnetic material are aligned in the same direction as the lines of induction. The molecular structure of a substance determines how well magnetic alignment is maintained. In permanent magnetic materials, the holding force is much greater than in those materials having little retentivity.

The hysteresis cycle is illustrated graphically in figure 15, where magnetic induction or flux density  $B$  is plotted versus the magnetizing force  $H$ . The magnitude of flux density increases in the directions up or down from the center horizontal line. The direction and magnitude of the magnetizing force is indicated to the right or left of the vertical center line. An arbitrary relationship is used and no definite values indicated.

The initial portion  $Od$  is the normal saturation curve for the soft iron used in this example. As the magnetizing force is increased, the flux density will also increase, but at a decreasing rate until a maximum value is reached. Further increase in the magnetizing force has but little effect on the value of flux density. This condition indicates that maximum alignment of the magnetic regions within the material has been reached. This is known as magnetic saturation.

**Remanence or residual magnetism.** When the magnetizing force is gradually reduced to a zero value, the flux density will also decrease, but not at the same rate as the original saturation curve  $Od$ . A certain value of flux density  $Oa$  will remain which indicates that the material has retained a value of magnetism. The amount of magnetism remaining after the inducing field is removed is termed remanence or residual magnetism. Permanent magnets retain a great percentage of the induced magnetism whereas those materials used in applications where the magnetic field is changing are chosen with regard to low remanence.

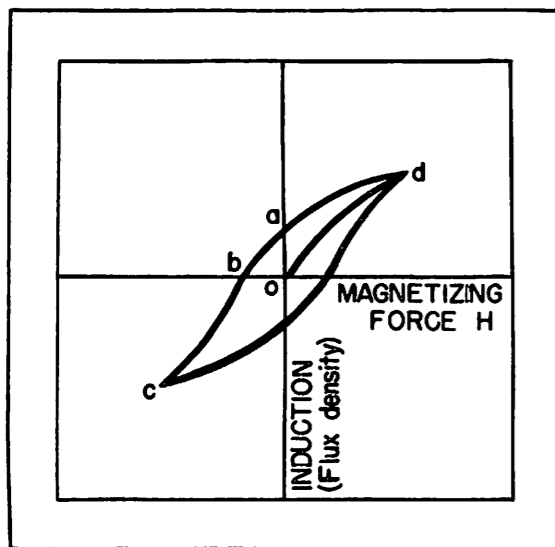

FIGURE 15—The hysteresis loop.

**Coercive or demagnetizing force.** In order to remove the residual magnetism  $Oa$  and reduce the magnetism of the sample to zero, or an unmagnetized condition, it is necessary to use a magnetizing force of an opposite direction. The opposing magnetizing force overcomes the tendency of the magnetic regions within the material to maintain alignment and restores them to random directions. The value of demagnetizing force required is indicated in Figure 15 as  $Ob$ , and is called coercive or demagnetizing force. The magnitude of this force is dependent upon the remanence and the ferromagnetic properties of the material.

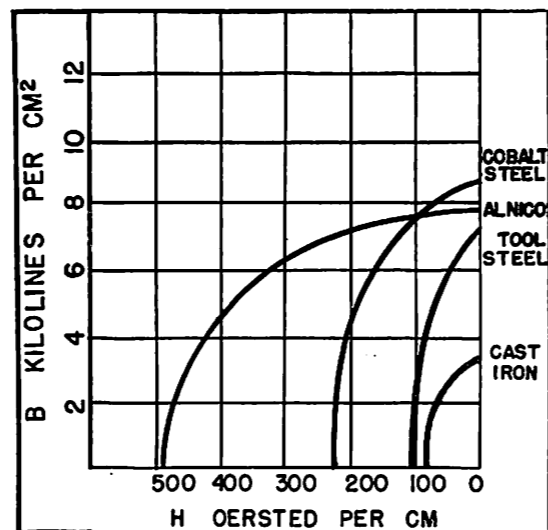

FIGURE 16—Characteristics of permanent-magnet materials.

When the magnitude of the magnetizing force is again increased, after the sample has been reduced to zero magnetism, saturation will again be attained at point  $c$  on the graph. It will be noted that the value of flux density at  $c$  is the same as at  $d$ , indicating that the alignment of magnetic regions can reach a certain value regardless of the direction of the inducing field.

The portion of the hysteresis cycle from  $c$  to  $d$  is merely a mirror image showing the same value of remanence at zero magnetizing force and the same value of coercive force to completely demagnetize the sample. Changes in flux density will always seem to occur later than changes in the magnetizing force, hence an implied time lag which is known as hysteresis.

**Hysteresis loss.** The hysteresis loop for a magnetic material represents the energy loss in ergs per cycle of changing the direction of magnetism in a material between two values of flux density. Although this phenomenon will be more adequately covered in the study of alternating currents, the basic principle is brought up at this time in order to distinguish sharply between materials used for permanent magnets and materials in

which there will be recurring changes in the magnetizing force.

Hysteresis loss is due to inter-molecular friction within the material when the magnetic regions or domains are caused to turn and change their directions with changes in the direction of the magnetizing force. This loss is made evident in the form of heat energy and is dependent upon the volume of the material, the maximum flux density attained, the coercive force required to demagnetize, and the speed of reversing or changing the magnetizing force.

The materials used in the manufacture of commercial dynamos and transformers wherein the magnetizing forces are constantly changing direction are chosen with an eye to economy versus low hysteresis losses. Various grades of iron and steel in cast and sheet forms are used since these materials have little remanence and require relatively little coercive force to reduce their magnetism to zero. Usually one oersted or less is the coercive force required.

By contrast, magnetic materials selected for permanent magnets are of a kind that will require large values of coercive force to be demagnetized. Figure 16 above shows the coercive force required for several types of materials used for permanent magnets; those requiring the greatest coercive force are the best and usually very expensive.

**Force on a conductor in a magnetic field.** During his experiments, Ampere discovered that a wire through which an electric current was passing experienced a force tending to move it in a particular direction, when it was placed in a magnetic field.

A relationship may be established between the direction and magnitude of the force on a current-carrying conductor in a magnetic field by the association of several concepts of magnetism previously studied.

Lines of force, when parallel and of the same direction, act as if they exert a mutual repelling force on one another; but when oppositely directed, they act as if a force of attraction were exhibited. At points or regions of coincidence between two magnetic fields, lines of force in the opposite directions will cancel but the net result is an increase in the strength of the composite field as shown in figure 3C.

The magnetic field is concentric with a conductor and proportional to the current flowing, having its greatest field intensity perpendicular to the direction of the current. This is shown in figure 1. The direction of the field is always taken counter-clockwise about the conductor, when looking in the direction of current flow.

External to a magnet or a solenoid and iron core which comprises an electromagnet, the field is directed from the north to the south pole.

These concepts provide a means by which all rotating machinery, based on the use of electricity, may be analyzed.

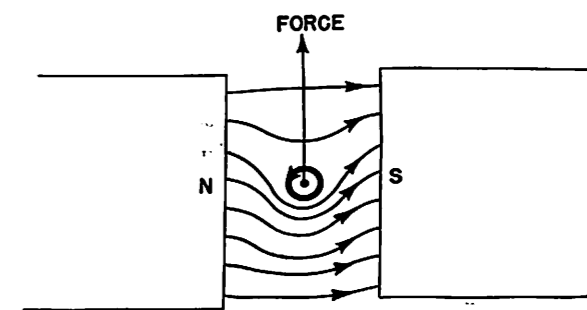

FIGURE 17—Relation of flux direction, current direction, and force on a conductor placed in a magnetic field.

Figure 17 illustrates the application of these concepts. A copper conductor, through which the current is flowing into the page, is placed in a uniform magnetic field between two parallel pole faces. The field direction as indicated is from north to south. The concentric field about the conductor caused by current flow will interact with the lines of force between the pole faces in the following manner:

Above the conductor the lines of force of each field are of opposite directions, therefore they will tend to cancel and thus reduce the total field intensity in the vicinity above the wire. Below the conductor the lines of force of each field are parallel and result in a concentration of the lines and hence a stronger magnetic field. There will then exist a force of attraction above the conductor and a force of repulsion below the wire that combine to produce a force that will tend to move the wire upward as shown in figure 17.

It must be stressed at this time that the forces as produced are not actually pushing the wire physically, but exist between two magnetic fields; however, since one field is produced by the current passage through the wire, the effect is the same and the wire will move when the force developed overcomes inertia, gravity, or friction that tends to restrict the movement of the wire.

If either the direction of the current flow, or the direction of the field between pole faces be reversed, the force exerted on the conductor will also reverse. However, when both directions are changed at the same time the force will remain unchanged.

By the application of basic concepts in this manner and perhaps utilizing a rough sketch or a mental image of the individual fields produced, it is possible to determine the direction of the conductor movement far easier than by means of the hand and finger rules set forth in various text books. With the left and right hand rules as applied to rotation of motors and generators, there exist too many possibilities of error.

A quantitative analysis of the force exerted on a current-carrying conductor placed in a magnetic field may be carried out in the same logical manner.

The field intensity produced by a unit pole has been previously derived as being equal to  $\frac{m}{\mu r^2}$ , where  $m$  is unit pole strength,  $\mu$  is the permeability and equal to 1 in air, and  $r$  is the separating distance in terms of centimeters.

The force exerted per unit pole in a magnetic field is a product of pole strength  $m$  and the field intensity  $H$ , expressed in dynes.

The field intensity produced at the center of a loop formed from a current-carrying wire was derived as

$$H = \frac{2\pi N I}{r} \text{ oersteds,}$$

where  $I$  is in abamperes and  $r$  is expressed in centimeters,

By substitution:

$$F = mH = m \left( \frac{2\pi N I}{r} \right) \text{ dynes.}$$

This represents the force exerted on a unit magnetic pole at the center of a loop of wire through which an electric current is passing. In order to establish a better relationship between a magnetic field produced by a magnet and that produced by current passage in a wire, the above formula must be modified slightly. Both the numerator and the denominator are multiplied by  $r$ , a perfectly straightforward mathematical operation.

$$F = m \left( \frac{2\pi N I}{r} \right) \frac{r}{r} = \left( \frac{m}{r^2} \right) I (2\pi r N)$$

In simplifying this manipulation still further, recall that in air permeability is unity and field intensity is numerically equal to flux density; therefore, the flux

density  $B$  may be substituted for the quantity  $\left( \frac{m}{r^2} \right)$  that represents the field intensity per unit pole in the above formula.

The current flowing in the conductor is represented by  $I$  in the above formula and is expressed in abamperes. The quantity  $(2\pi r N)$  represents the total length of conductor in a coil of  $r$  centimeters radius and  $N$  turns.

Simplified thus:  $F = \frac{B I L}{10}$  dynes, where  $B$  is the flux

density in gaussess that exist between pole faces,  $I$  the current in the conductor in practical amperes, and  $L$  is the active length of the conductor in the field expressed in centimeters.

The force obtained by this relationship is directed mutually perpendicular to the direction of the field and

the current flow as can be readily noted by reference to figure 17. This formula holds true only when the conductor or conductors are themselves perpendicular to the direction of the field between the pole faces.

When the conductor is not at right angles to the field but at some angle  $\phi$  less than  $90^\circ$ , the force exerted is expressed:

$$F = \frac{B I L}{10} \sin \phi \text{ dynes.}$$

In all practical applications, however, every possible effort is made to maintain a perpendicular relationship between the field direction and the axes of the active conductors.

The electromagnetic principles and concepts brought forth in this assignment will be used repeatedly in connection with the study and analysis of meters and rotating electrical machinery. The study of alternating currents presumes an understanding of magnetic fields produced by current flow in conductors and their relationships to other magnetic fields.

### Questions—on Basic Physics, Part 13

1. Calculate the force in dynes per unit pole at a distance of 12 centimeters from a straight conductor carrying a current of 42 amperes. What would be the force in dynes/unit pole at a point 1 centimeter from the conductor?
2. How many 800-lb pigs of cast iron may be lifted by an annular ring electromagnet whose inner pole is 8 inches in diameter? The annular ring has an inner diameter of 10 inches and an outside diameter of 14 inches. The flux density is 6000 gauss.
3. What is the maximum-weight steel slab that could be lifted by a horseshoe-type electromagnet with pole faces 10 inches square? The flux density is 3000 gauss.
4. It is desired to produce a uniform flux of 1,250,000 maxwells in a one-half-inch air-gap between parallel pole faces each having an area of 5 square inches. Calculate the current and size wire to be used to produce this flux using a solenoid of 1200 turns. Current density taken at 1000 circular mils per ampere.
5. A conductor carrying a current of 17 amperes is placed in a magnetic field similar to figure 17. A uniform flux of 3,000,000 maxwells exists in the field between pole faces 2 inches square. Calculate the force on the conductor. What force would be exerted if there were 20 closely grouped conductors each carrying the same current of 17 amperes?

## LIGHTWEIGHT MODEL 15 TELETYPEWRITER

The Model 15 Teletypewriter now has a "new look." With the advent of this new machine, the old Model 15 with its four-legged table and box-like cover will gradually fade out of the picture.

Actually, quite a few changes are incorporated in the new lightweight printer, but only a few are apparent. Figure 1 reveals that a new streamlined console cabinet has been provided in place of the former table and cover. The new cabinet has a built-in sliding table to which the teletypewriter is fastened. The table has two front legs which act as supports when the table is pulled out for servicing the machine, as shown in figure 2. The console type of construction allows several Model 15 cabinets to be mounted side by side inasmuch as a handwheel replaces the platen crank of the standard Model 15.

The principal differences aside from the cabinet are the replacement of the cast iron frames of the printer with cast aluminum, and the combining of the base and keyboard into one unit. Other changes include increasing the size of the dashpot and carriage return spring, elimination of the polar relay, and reduction of the size and weight of the type basket and many of the component parts. These changes have made



FIGURE 1—The new lightweight Model 15 Teletypewriter.

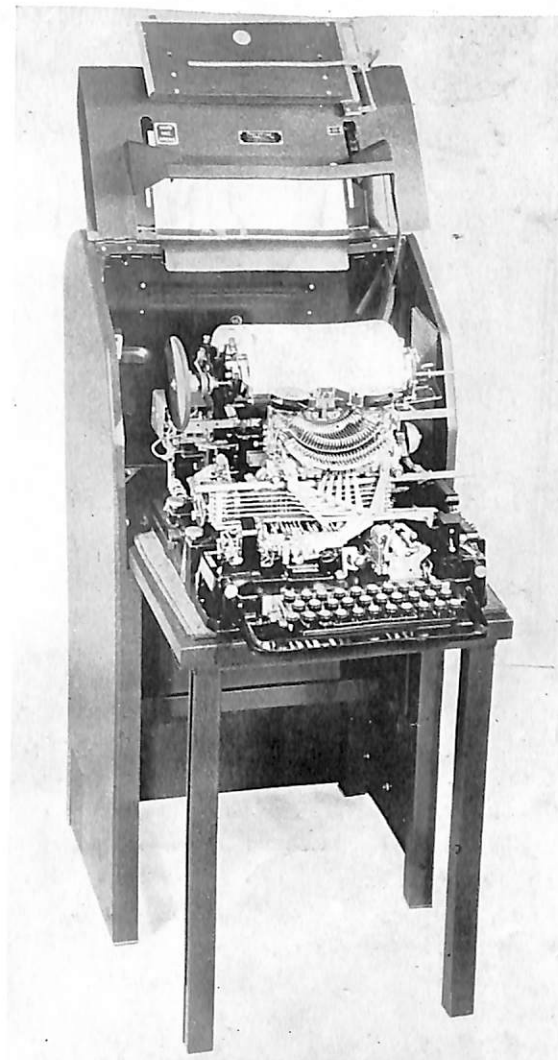

FIGURE 2—The new Model 15 console showing the table extended so that the teletypewriter can be serviced.

practically no improvement in the amount of space required, but the new machine is approximately 20% lighter in weight than the old Model 15.

The Model 15 lightweight consoles were procured specifically for ships and should be used in all new installations and for replacements in present installations when required. They are in current production and deliveries are being made to ship installation activities. They should be installed whenever shipboard requirements exist regardless of the stock of the standard Model 15. These new equipments should not be installed permanently at any shore activity without prior approval by the Bureau of Ships.

Unlike other Model 15 teletypewriters, the new console is not provided with a rectifier power supply for line current. This is because, aboard ship, it is the intention to eventually have all line current provided from one source and distributed through the teletype panel thus eliminating the need for individual rectifiers.

