

CONFIDENTIAL

JANUARY 1947

BUSHIPS

Electron

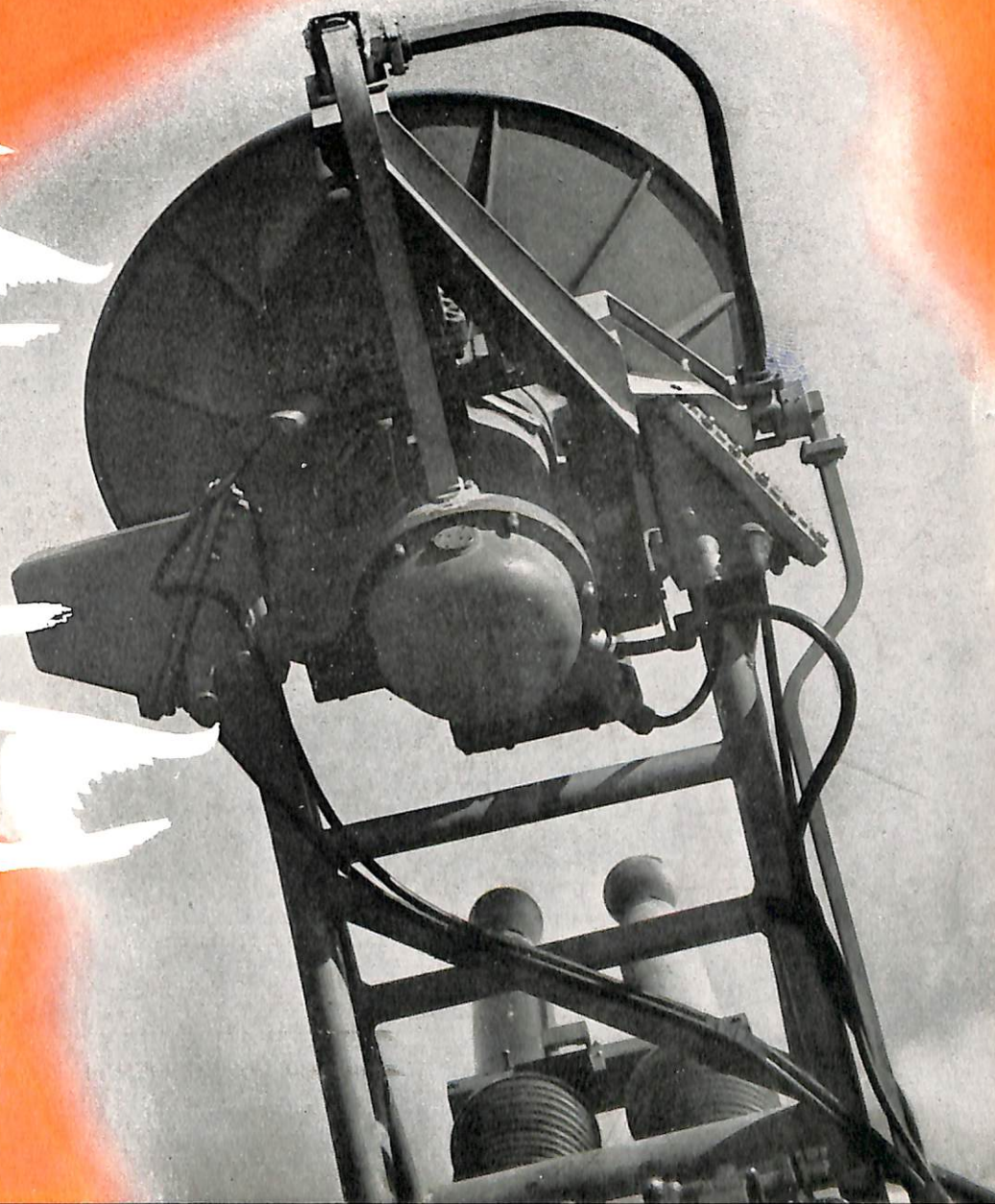

NavShips 900,100

A New Search Radar..... 1

X-Band Phenomenon 12

Coax Dry-Air Requirements..... 13

Watch Your Kilocycles..... 17

Teletype Modification 17

RADAR (Part 3)..... 19

BUSHIPS

ELECTRON

A MONTHLY MAGAZINE FOR RADIO TECHNICIANS

DISTRIBUTION: BUSHIPS ELECTRON is sent to all activities concerned with the installation, operation, maintenance, and supply of electronic equipment. The quantity provided any activity is intended to permit convenient distribution—it is not intended to supply each reader with a personal copy. To this end, it is urged that new issues be passed along quickly. They may then be filed in a convenient location where interested personnel can read them more carefully. If the quantity supplied is not correct (either too few or too many) please advise us promptly.

CONTRIBUTIONS: Contributions to this magazine are always welcome. All material should be addressed to

The Editor, BuShips ELECTRON
Bureau of Ships (Code 993-b)
Navy Department
Washington 25, D. C.

and forwarded via the commanding officer. Whenever possible articles should be accompanied by appropriate sketches, diagrams, or photographs (preferably negatives).

CONFIDENTIAL: BUSHIPS ELECTRON has been classified confidential in order that information on all types of equipment may be included. It should be shown only to concerned personnel as provided in the U.S. Navy Regulations. Don't forget this includes enlisted personnel!!

BUSHIPS ELECTRON contains information affecting the national defense of the United States within the meaning of the Espionage Act (U.S.C. 50; 31, 32) as amended.

BUREAU OF SHIPS

NAVY DEPARTMENT



Dual antenna assembly employed with SG-6 Radar Equipment.

Although Navy radar equipment has met and overcome a great many obstacles and operational challenges, no single equipment was available to provide coverage at both very high and very low angles. As a result, coordinated attacks by low-flying torpedo planes and overhead snoopers presented a serious problem in detection and interception. As a stop-gap measure the SO-11, SCR-720, and the SG-series equipments were modified for Zenith Watch and employed in conjunction with a second radar for covering the low angles. However, it became more and more apparent that a new design was necessary which would provide, in one equipment, a defense against surprise air attacks whether they were made from low altitudes (surface approach) or directly overhead. Steps were taken by the Navy, in conjunction with the Raytheon Manufacturing Co., to develop such an equipment.

The result of this high priority assignment was not realized as soon as was desired due to the war ending so abruptly, cutback of contracts, etc. However, the first model of this new equipment was eventually finished and has been added to the SG family, carrying the official title SG-6. This radar uses a combination of high power (125 to 285 kw peak power as measured

A New Search Radar

at the antenna) and a dual antenna to perform the double duty required. The operating frequency of the SG-6 is in the 5600-Mc band. A choice of either 0.37- or 1.3-microsecond pulse width is provided.

As shipped, the equipment includes thirteen separate units; nine units for the radar proper, a synchro amplifier, and three units of the VJ Radar Repeater (see page 21, ELECTRON for December 1945). Two units of the VJ, the motor-driven selector switch, and the voltage regulator, are not used with the SG-6 installation. The VJ is used as the master PPI for the SG-6 system. The units which comprise the radar proper are the Dual Antenna Assembly, Switch Box, R-F Filter Unit, Power Transformer, Modulator, Transmitter-Receiver, General Control Unit, Training Control Amplifier, and a Range Indicator-IFF Coordinator assembly. The dual Antenna Assembly consists of two major parts; an upper reflector and a lower pedestal assembly. The upper assembly is composed of the surface-search and zenith-search reflectors with feeds, the waveguide-selector switch, and controlling microswitches which permit the selection of either zenith or surface search. The lower assembly contains the drive motor, gear trains, slip-ring assembly for the waveguide-selector switch, a type 6G synchro, and various minor components such as ship's heading marker microswitches, a safety switch, terminal strips, and heater elements.

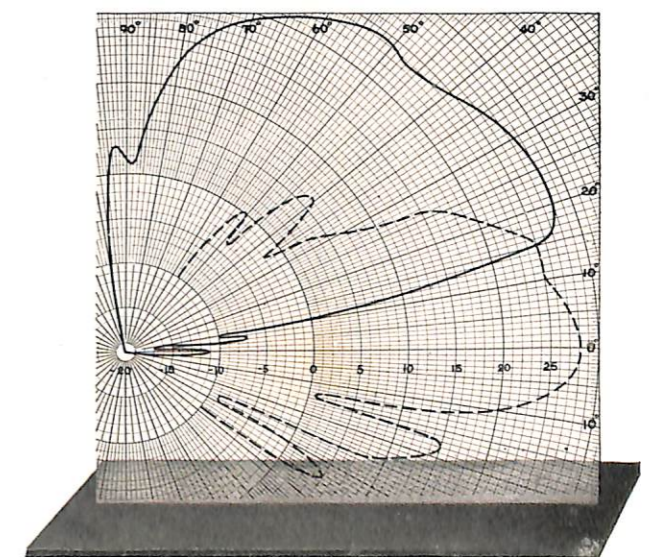

Vertical radiation patterns of the SG-6, both for surface and for zenith search. The surface-search pattern is indicated by the dotted line, while the zenith-search is designated by the solid line.

CONFIDENTIAL 1

The remainder of the system may be identified and the inter-cabling observed by referring to figures 1 and 2 which are flow charts for the equipment. On these charts it is seen that the ship's power is fed directly to the switch box, which contains a conventional two-pole line switch and two 60-ampere fuses. When this switch is closed, power is fed directly to the r-f filter, which effectively isolates the equipment from the ship's power by means of two sealed pi-network filters. These filters are designed to provide a minimum attenuation of 60 db to all frequencies between 150 kc and 150 Mc, and at the same time carry the entire load of the SG-6, even at 115-volts. The output of the filters is carried to a conventional 5-kva, 60-cycle, single-phase transformer which converts the ship's power to the required 115-volts. This transformer is designed for inputs of 440 or 220 volts and an output of 115 volts. An additional tap on the secondary provides a means of obtaining full 115-volt output when the input voltage is normally 10% below its rated value. It may also be used to supply power to the VJ repeater when 115-volt, 60-cycle, single-phase power is not available.

The 115 volts, either from the ship's power or from the power transformer, is fed directly to the modulator where it is fused and distributed to the other units of the system. Although the modulator acts as a distribution center, its primary purpose is to furnish a high-voltage negative pulse for keying the transmitter. The modulator contains, in addition to fuses, relays, and an auto-transformer, a trigger chassis, a thyratron modulator (keyer) tube, both high- and low-voltage power supplies, and standby and radiation hour meters.

The trigger chassis generates a trigger at a repetition rate between 600 and 660 pps. The actual pulse rate is variable between these two extremes by a motor-driven capacitor which is controlled from the General Control Unit. This trigger is used to fire the modulator-keyer tube, which is part of a keying circuit consisting of the keyer tube, a high-voltage transformer, a charging diode, two pulse lines, and a diode for restoring the charge on the pulse line in use. Two pulse lines, which are nothing more than lumped-constant delay lines, make possible a choice of 0.37- or 1.37-microsecond pulse width. The selection of the pulse width is accomplished by a motor operated switch which is controlled from the General Control Unit. The trigger which fires the thyratron is not used elsewhere in the radar system, as triggers for the Range Indicator-IFF Coordinator and the VJ Repeater are obtained from a trigger winding on the pulse transformer located in the Transmitter-Receiver.

The Transmitter-Receiver comprises six units: Transmitter, Receiver, Video Amplifier, Trigger-Delay Unit, Echo Box, and Monitor Scope. The Transmitter con-

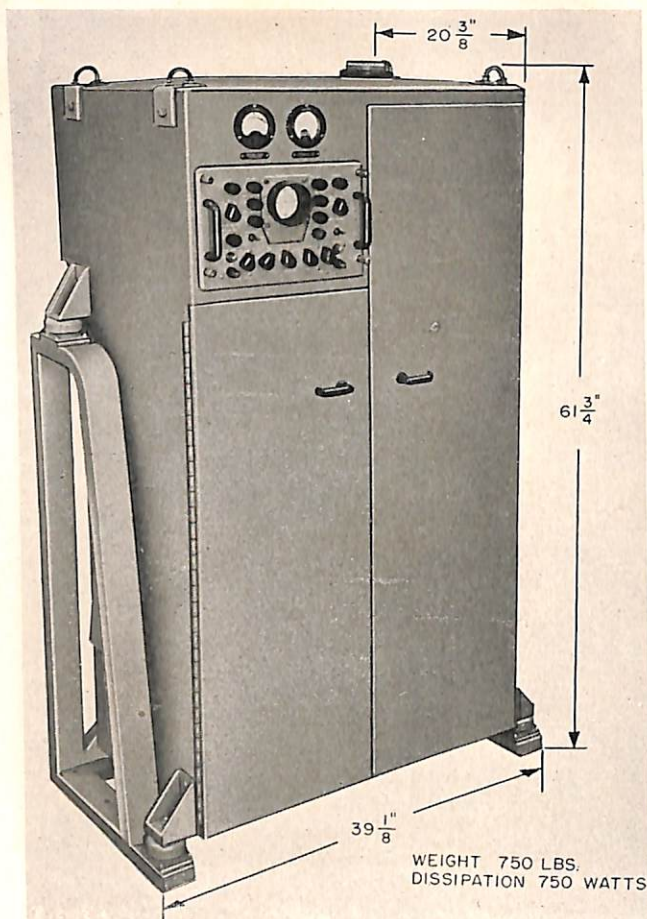

Transmitter-Receiver unit of the SG-6 Radar. Included in this unit are the Echo Box, Monitor Scope, Receiver, Trigger-Delay Unit, Transmitter, and Video amplifier.

sists of a high-voltage pulse transformer, a magnetron filament transformer, an under-current relay, and a magnetron oscillator feeding directly into the waveguide. The receiver is a standard superheterodyne utilizing a type 1N23B crystal for the first detector. Included in the receiver are special anti-jam features such as STC (*Sensitivity Time Control*), FTC (*Fast Time Constant*), IAVC (*Instantaneous Automatic Volume Control*), AFC (*Automatic Frequency Control*), and HVP (*High Video Pass*). The HVP circuit includes an amplifier and third detector and is designed to remove certain kinds of jamming interference. In addition to the above features, the receiver also includes a crystal checking circuit with a meter on the front panel. The Video Amplifier is a two channel amplifier, one for the range scope and the other for the VJ repeater and any other repeaters which may be used. Provisions are made in the repeater channel to enable the introduction of IFF signals or range marks from a standard Navy crystal range calibrator. An unsynchronized 450-kc multivibrator provides an optional ship's-heading marker for repeaters. The Trigger-Delay Unit contains four tapped trigger-delay lines in series, voltage-dividing resistor networks, and switches for terminating unused

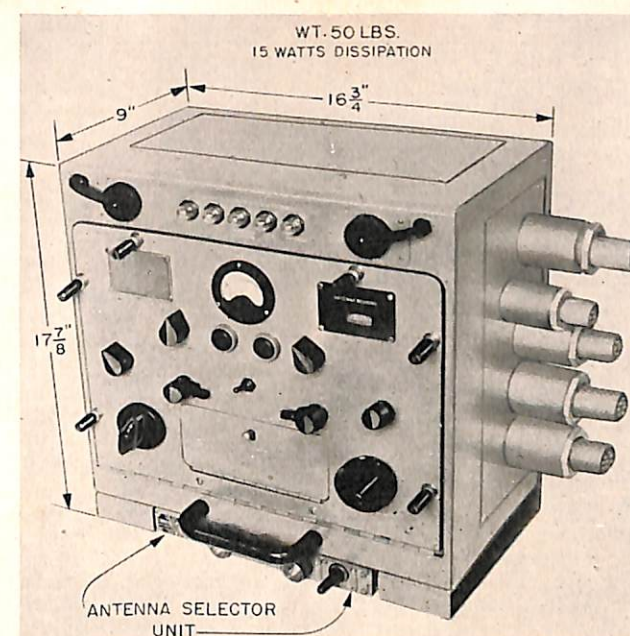

General Control Unit of the SG-6, with Antenna Selector Unit mounted beneath. The GCU is the main control chassis for the entire equipment.

outputs. It permits delaying the indicator triggers a sufficient time to compensate for system delays.

The Echo Box is manually operated, employing a type 1N23B crystal. The input to the box is normally connected to the directional coupler when used for any of the following: overall check of radar performance, indication of power output, spectrum analysis, frequency measurement, tuning of the r-f system, and general trouble shooting. The input may also be temporarily connected to a probe in the slotted section of the waveguide for measuring standing-wave ratio. When employed in the latter case the indication is observed on a 0-100 microampere meter which is located on the front panel of the transmitter unit.

The Monitor Scope combines a 3-inch oscilloscope with a servoscope (synchroscope). It includes an internal trigger generator, video amplifier, and power supplies. Although normally installed in the transmitter for convenience in tuning, it may be removed and used as a portable instrument for checking wave shapes when trouble shooting. The unit is interchangeable with corresponding units of other standardized search radar equipments and is suitable for general radar servicing.

The General Control Unit is the center of all controls for the system. This unit, with the Antenna Selector Unit mounted beneath, contains all the controls used for operating and controlling the radar system except those for the range scope, the VJ repeater, and IFF equipment. The General Control Unit includes a meter for reading relative magnetron current, a dimmer for the manual train antenna bearing dial, a manual train

crank, and five high-temperature warning lamps connected to other units of the system. Two 115-volt 60-cycle outlets are provided for convenience in servicing (one can be used for the joe pot). By utilizing controls on this unit, the entire system can be energized, antenna rotation controlled, pulse width and receiver band width adjusted, pulse repetition rate varied, and receiver anti-jam features selected.

In the General Control Unit a switch designated "RADAR" and "PPI" is provided. The following table describes the function of this switch:

RADAR Position	PPI Position
1. Range Indicator <i>A</i> -scope sweep initiated by SG-6 radar trigger.	1. Range Indicator <i>A</i> -scope sweep initiated by delayed trigger from VJ.
2. Range ring (coincident with <i>A</i> -scope step) fed to VJ for use as a range ring.	2. No range ring fed from <i>A</i> -scope to VJ.
3. VJ sweep initiated by SG-6 trigger. (At the VJ this trigger may be delayed or undelayed by the VJ operator.	3. VJ sweep initiated by SG-6 trigger. (At the VJ this trigger is delayed by VJ circuits; the amount determined by setting of VJ Range Crank. This type of operation is known as Delayed PPI operation.

NOTE: If the VJ operator should have the delay switch in the undelayed position the *A*-scope sweep will be triggered without delay but range ring will not be fed to the VJ for use as a range ring.

The Antenna Selector Unit, which is mounted below the General Control Unit, has controls which permit a choice of either surface search or zenith search by means of a switch and relay operating the waveguide selector switch in the antenna. Two indicator lamps show which antenna (surface or zenith) is in use at any time.

Both the Range Indicator and the IFF Coordinator are housed in one cabinet. In the top of this cabinet a relay controlled by the RADAR-PPI switch at the General Control Unit (GCU) permits switching the trigger and range-ring cables connecting the VJ and SG-6 for delayed-range scope operation. See description of the General Control Unit for details. The Range Indicator includes a 5-inch *A*-scope, sweep and video circuits, power supplies, and a phantastron delay circuit (see page 38, *ELECTRON* for November 1945) for accurate ranging. In addition to the usual scope controls, a panel switch selects the following: "Normal" (signals only on *A*-scope); "Step" (Signals with range step) or "Expand" (Signals, no step, expansion of sweep). On the "Expand" position the *A*-scope sweep is expanded to approximately one thousand yards per inch on the 4-, 20-, and 80-mile scales. The beginning of the expanded section is at the same point where the range step would appear if the switch were in the "Step" position. When the switch on the GCU is in the "PPI" position the sweep may be delayed by the delayed trigger from the

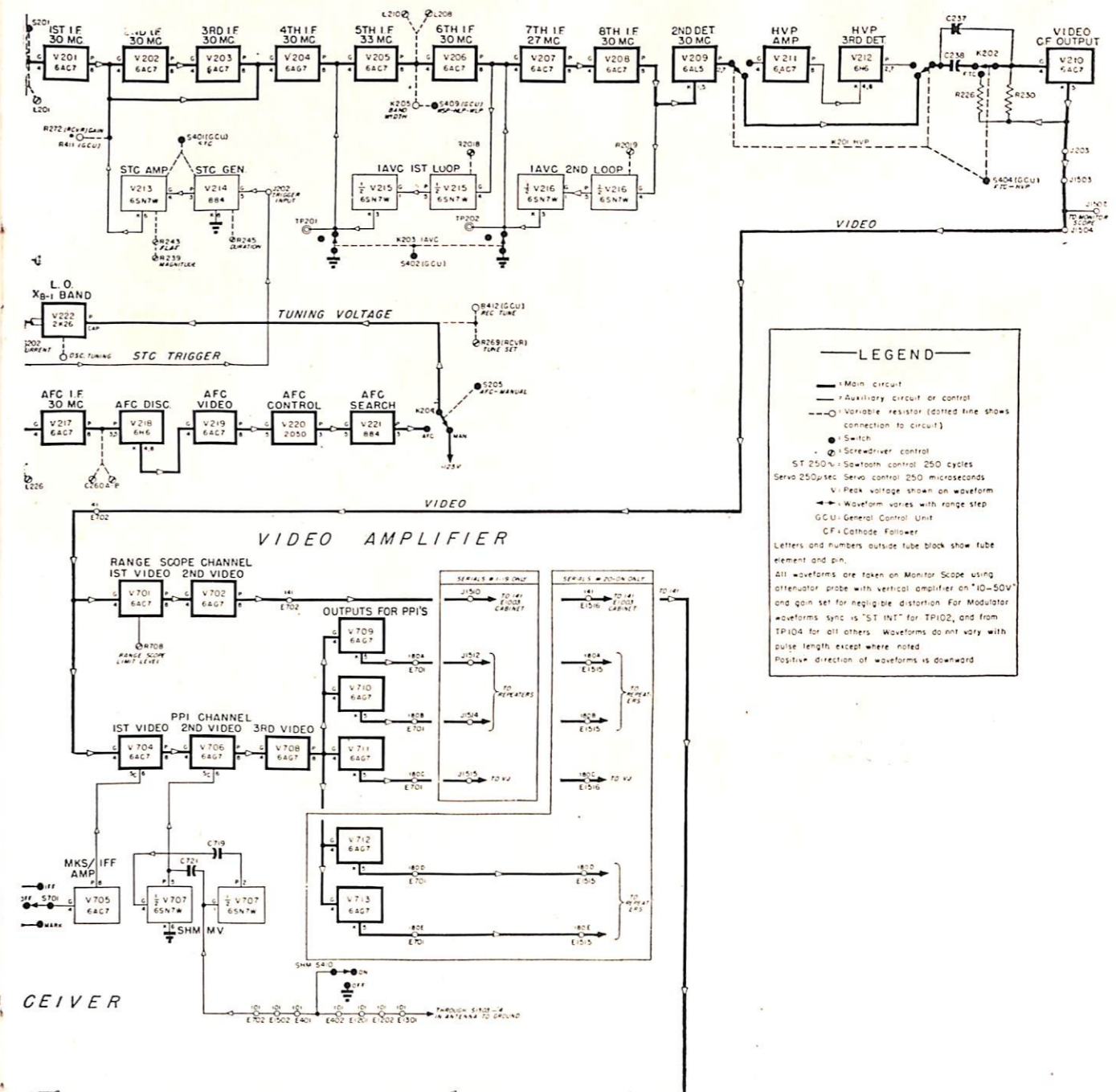
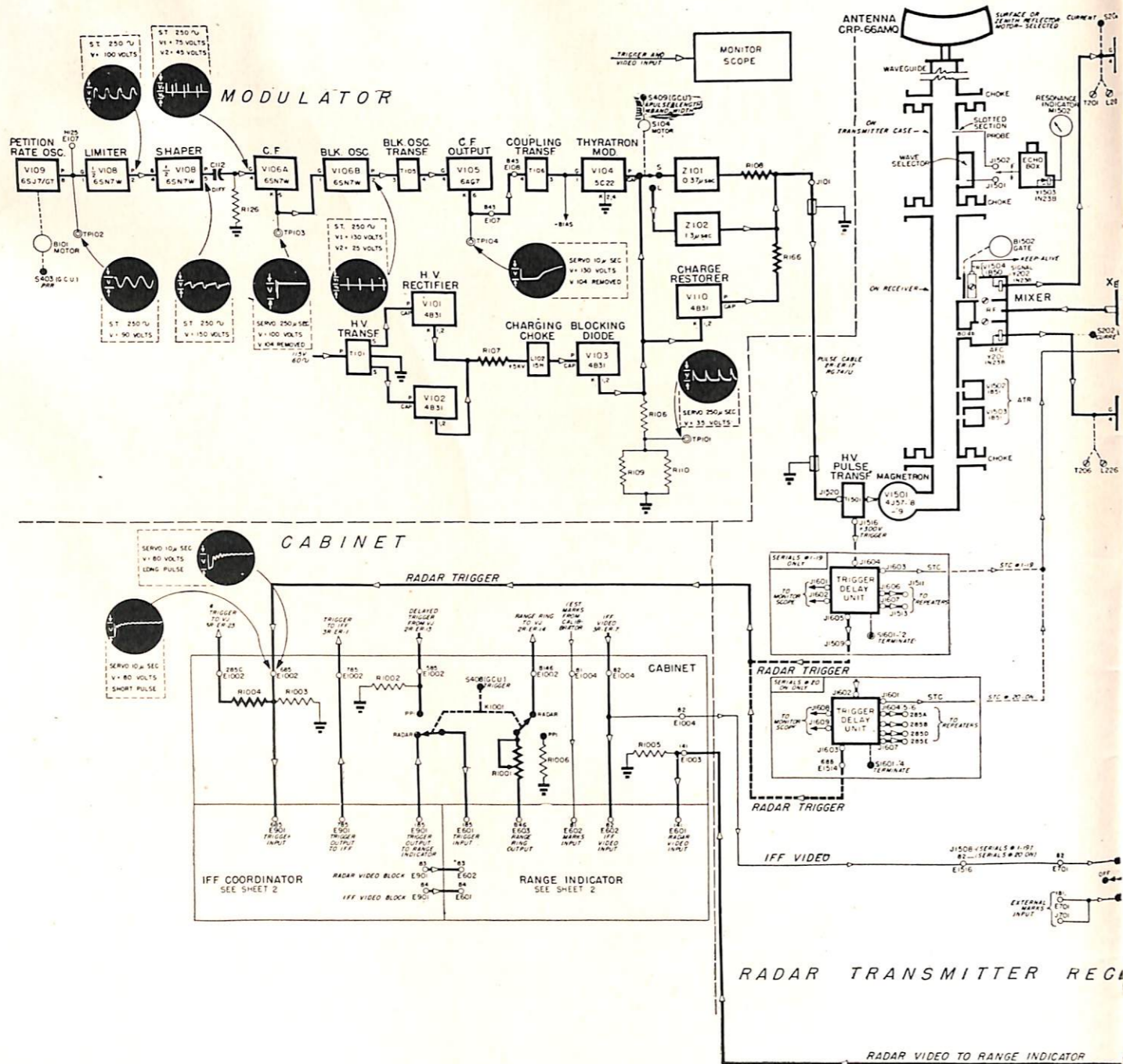

FIGURE 1—Part I of a servicing block diagram for the SG-6 Radar, showing important waveforms at various test points. Block diagrams for the VJ may be found in ELECTRON for December 1945.

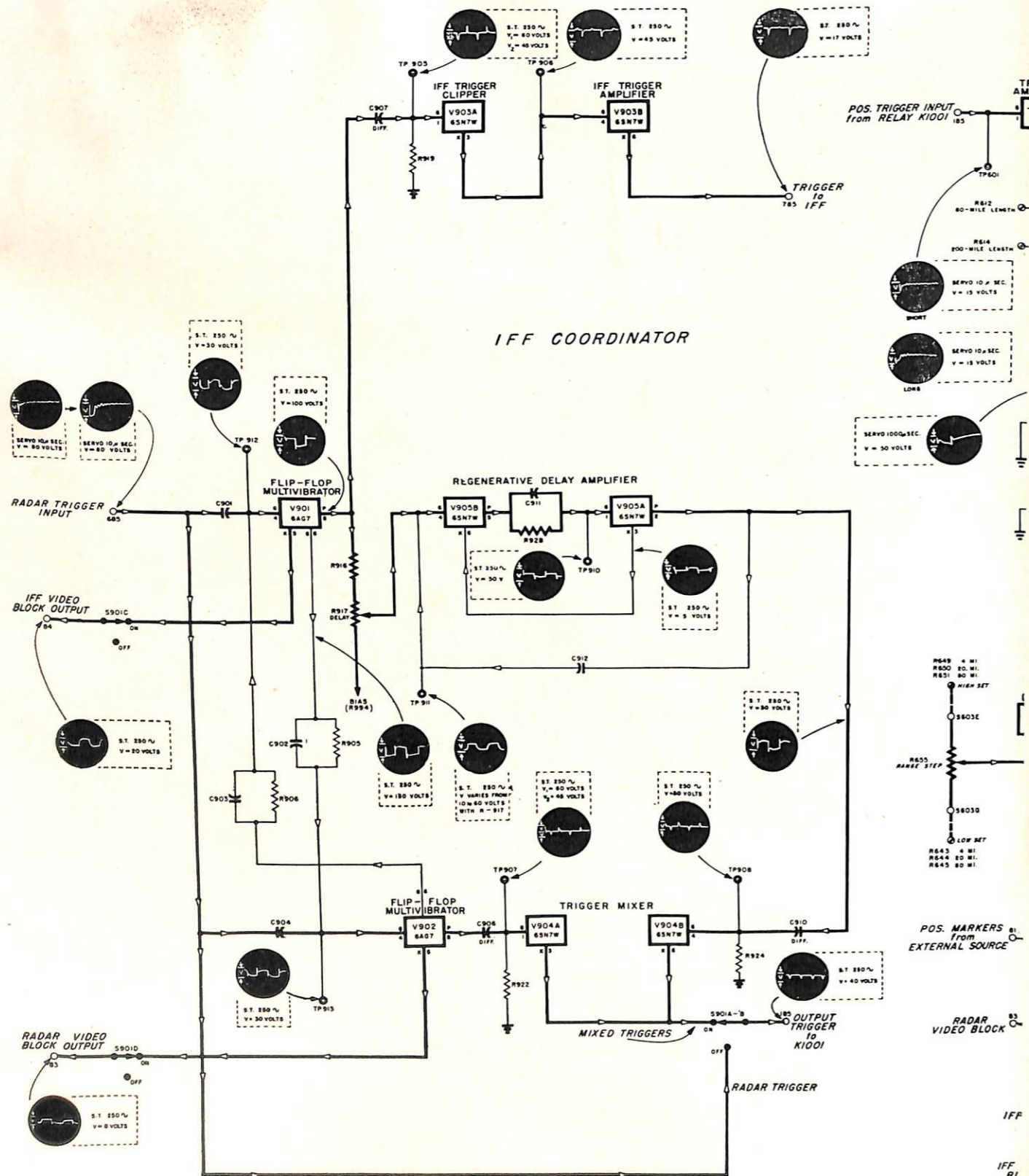
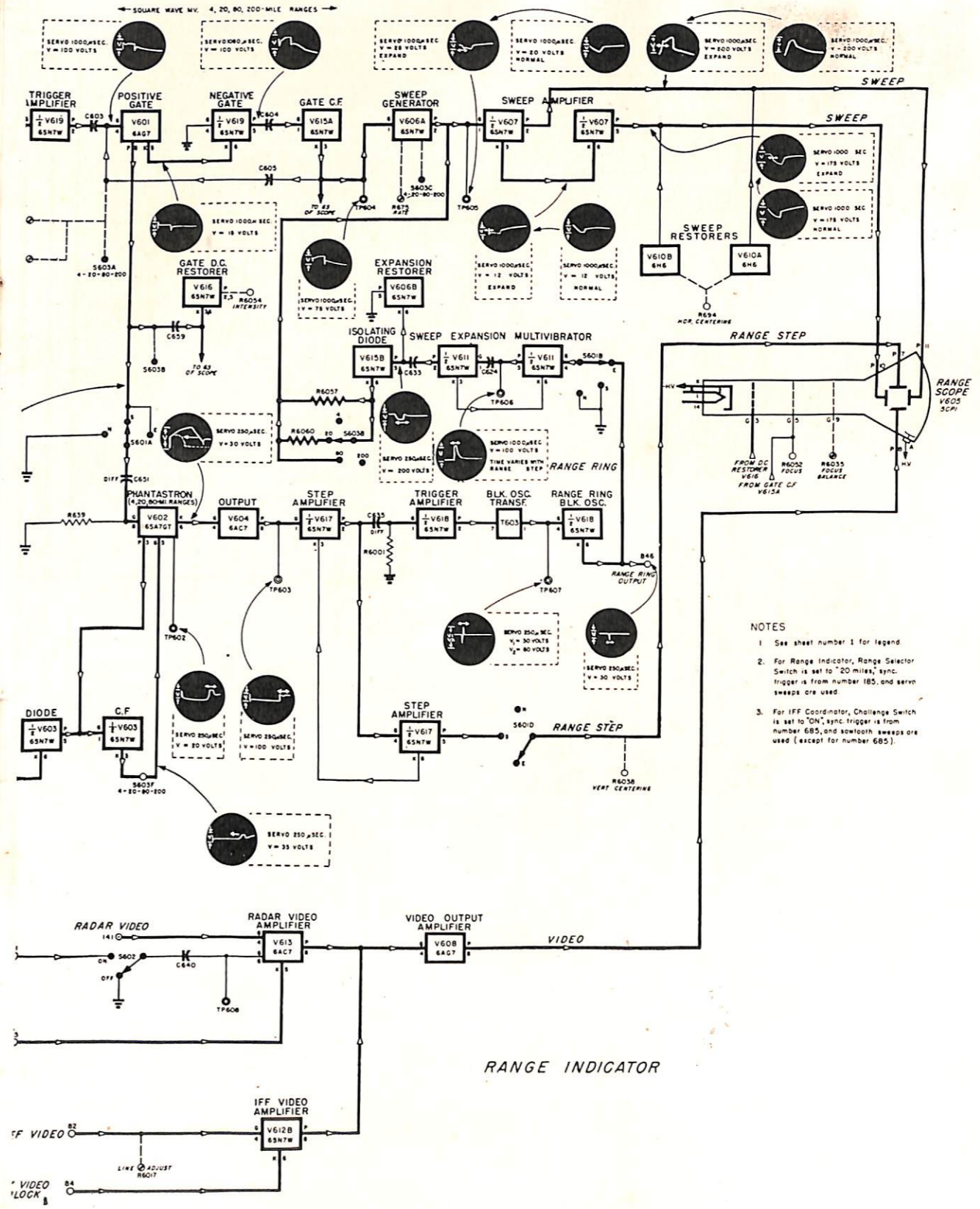
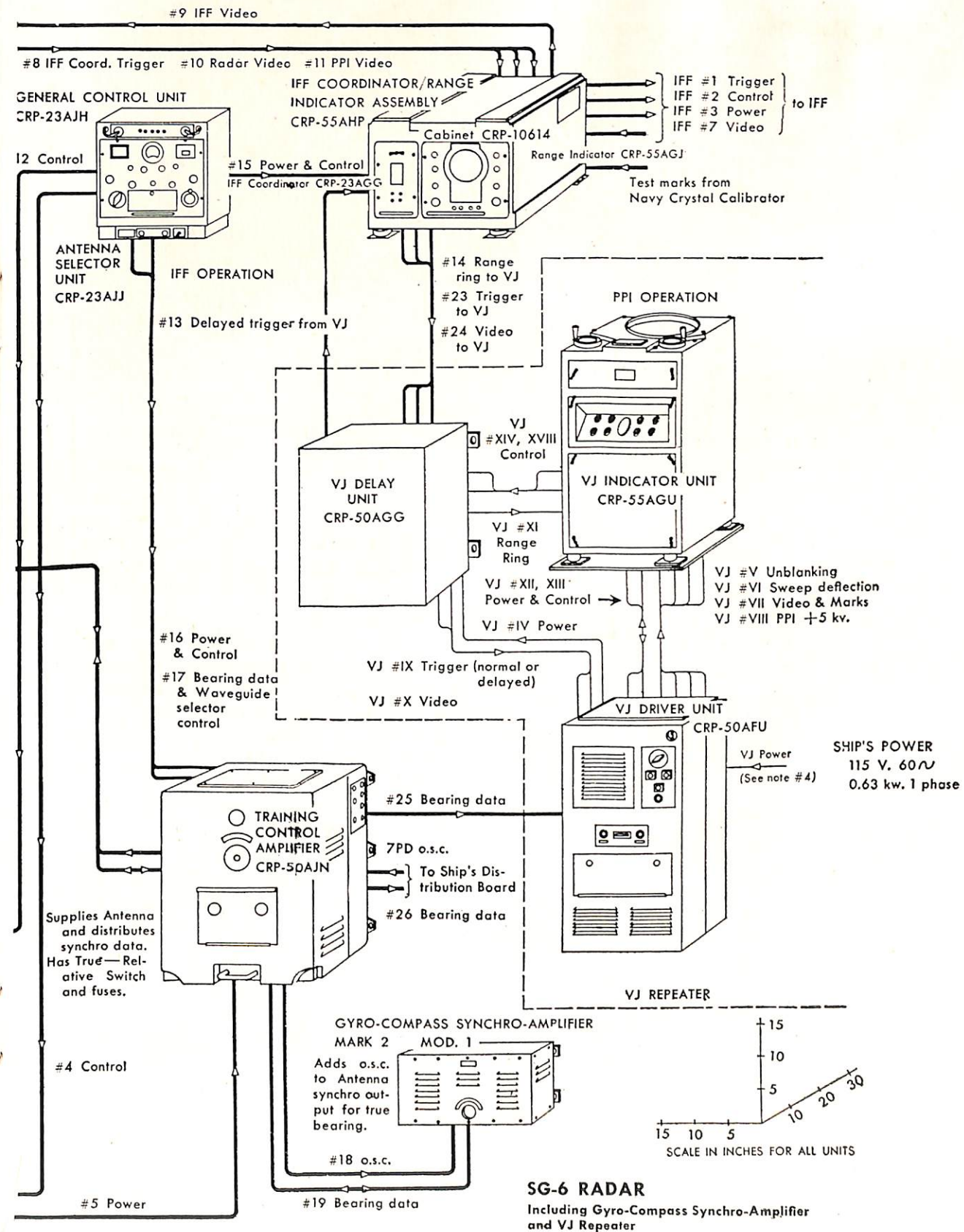
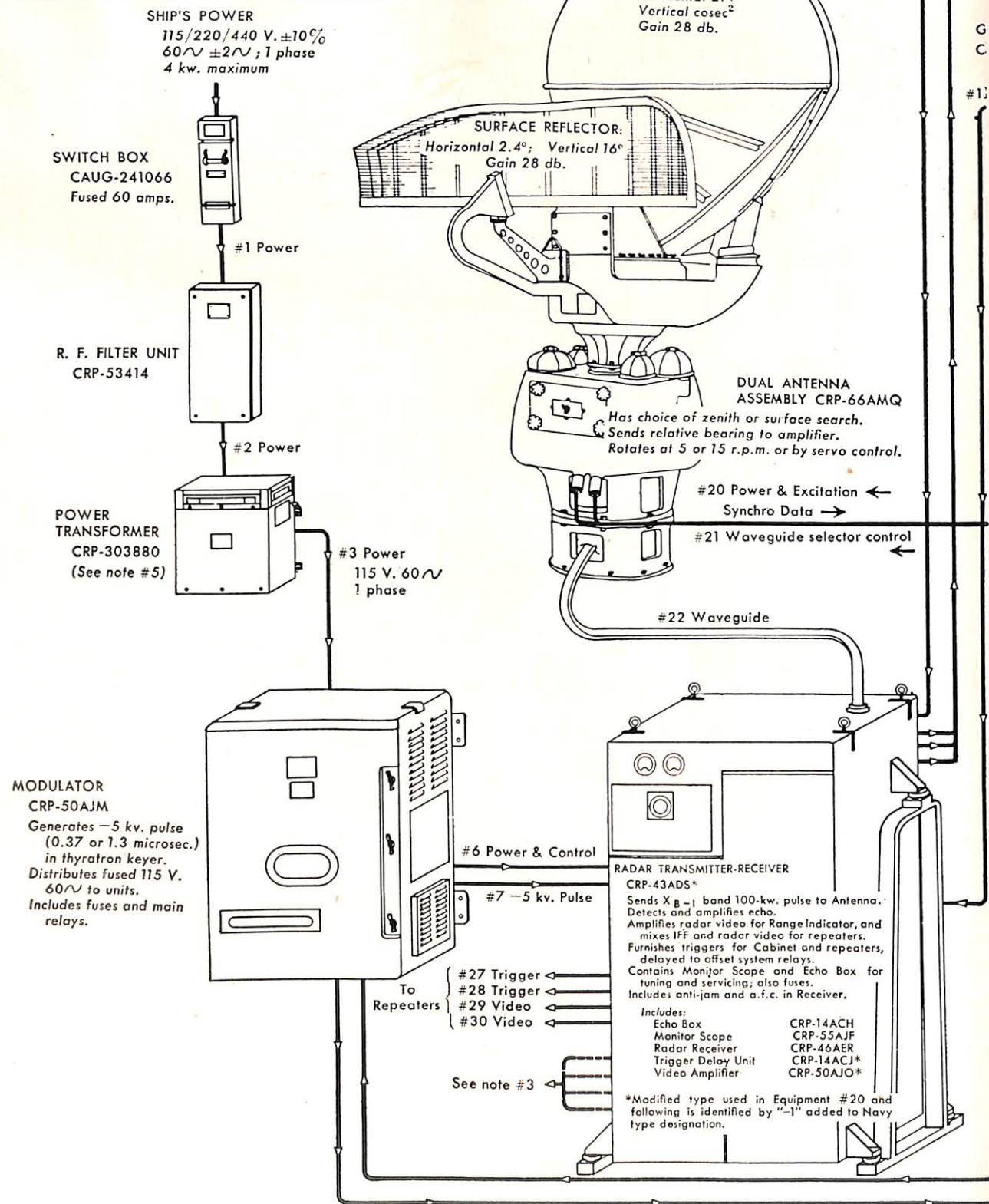

FIGURE 2—Part II of the SG-6 servicing block diagram. This is primarily a block breakdown of the Range Indicator/IFF Coordinator.



- NOTES
- See sheet number I for legend.
 - For Range Indicator, Range Selector Switch is set to "20 miles, sync. trigger is from number 185, and servo sweeps are used.
 - For IFF Coordinator, Challenge Switch is set to "ON", sync. trigger is from number 685, and sawtooth sweeps are used (except for number 685).

Pictorial cabling diagram of the SG-6 Radar and the VJ Radar Repeater, showing major inter-cabling and inter-connections.



VJ repeater. The range reading on the A-scope may be read in the normal manner with the step and range counter. The range ring output to VJ ("PPI" position at GCU) is useful for calibrating the range step on the A-scope by the fixed marks on the VJ repeater and, in addition, target designation information to the VJ operator is furnished from the A-scope, depending upon the position of the range step.

Terminals are provided at the Range Indicator for calibration purposes, using tests marks from any standard Navy range calibrator.

The IFF Coordinator furnishes both the IFF transmitter trigger and the range-scope trigger. It uses a "flip-flop" multivibrator circuit and regenerative delay amplifier to obtain two vertically displaced sweeps on the range scope. The radar signals project upward from the upper sweep of this scope and the IFF responses project downward from the lower sweep. On the panel is the control for IFF challenge, IFF echo suppression, and IFF relay reset. IFF receiver gain controls are mounted behind a small hinged panel accessible from the front of the unit. There are two internal controls, one of which permits varying the regenerative delay amplifier so that IFF response lies directly under the signal response. The other control determines the bias voltage obtained from the self-contained power supply.

The Training Control Amplifier acts as a synchro distribution center for the entire equipment. It supplies d-c power to the antenna drive motor and distributes antenna bearing data to the ship's radar distribution switchboard (if installed) and to the VJ repeater. It also serves to interconnect the Dual Antenna Assembly, General Control Unit, Gyro-Compass, Synchro Amplifier, Modulator, VJ Repeater, and the radar distribution switchboard. In addition to the interconnecting cabling, the unit provides a true-relative switch on the panel, fuses for the synchro excitation bus output and convenience outlet, and a servo amplifier. Another feature of this unit is a time meter which records tube life hours. The servo amplifier is used in the conventional manner for manual control of antenna rotation, but in addition it operates as a rectifier for automatic rotation control. There are two speeds available, 5 or 15 rpm. A 60-second time delay relay protects the tubes by allowing the filaments to warm up before power is applied to the plates. No operating controls are required, but there are four screwdriver controls provided on the chassis for routine maintenance adjustments.

A Gyro-compass Synchro Amplifier is used in the equipment to modify antenna bearing data by own ship's course when the Training Control Amplifier is switched to true bearing, so that all synchro data to repeaters will be in true bearing. A single switch on

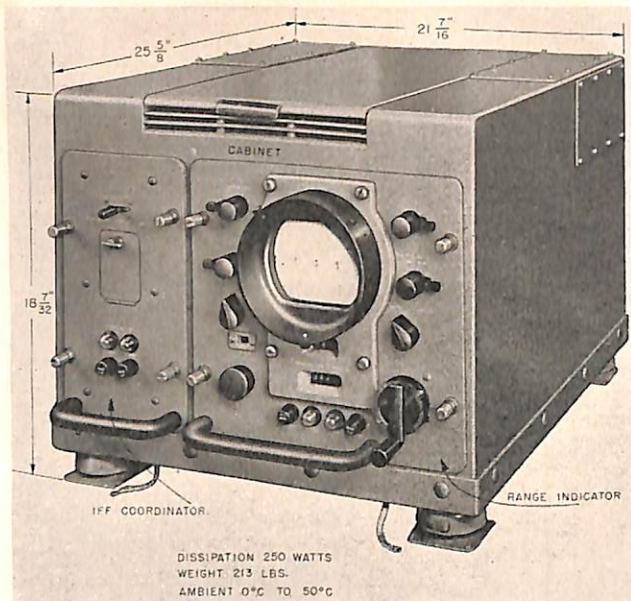

Range Indicator-IFF Coordinator employed in the SG-6 Radar. Note the scales marked on the faceplate of the scope.

the panel turns the unit on and off, although the dial lamps remain on as long as the 115-volt 60-cycle single-phase gyro-compass supply is energized. The unit consists of two main parts, the amplifier and the synchro-transmitter assembly. The amplifier contains one 6SN7W, two 6L6G beam-power tubes, and accessory components, while the synchro-transmitter assembly contains a 1-speed 1CT synchro, a 36-speed 1CT synchro, a two-phase servo motor, and a 1-speed 6DG synchro (output) plus wiring and gearing.

The 115-volt power is fed to the Modulator where it is stepped up by a high-voltage transformer and rectified in a full-wave rectifying circuit. One of the two pulse-forming lines in this unit is charged through a charging choke and a blocking diode. The line to be used, which determines the pulse width, is selected by a high-voltage, motor-operated switch, which is controlled from the General Control Unit. The pulse line and thyatron-tube modulator converts the 60-cycle voltage into either a 0.37- or 1.3-microsecond negative pulse of about 5000 volts. This pulse is applied to the primary of the pulse transformer in the Transmitter-Receiver. This transformer steps up the pulse to approximately 18,000 volts. These high-voltage pulses are then applied to the magnetron oscillator at a normal peak power of 460 kw with 115-volts input to the modulator, and a minimum peak power of 350 kw with 104 volts input to the modulator. When these pulses are applied to the magnetron, r-f energy of 125 to 285 kw peak power is generated and fed directly into the pulsed r-f system.

The r-f output is fed to the antenna assembly through a rectangular waveguide, entering the waveguide selector switch just before reaching the antenna. This switch, as previously pointed out, is controlled from the General Control Unit, thus permitting the operator to choose either surface or zenith search by merely switching the waveguide feed.

The pattern of the surface search antenna is 2.4° in the horizontal plane. In the vertical plane the pattern is a 16° fan beam with approximately 12° of cosecant-squared energy added on top of the fan beam. Thus when the ship is not in roll or pitch, the nose of the beam is as shown in the antenna pattern, making an above-horizon coverage of approximately 22° . The pattern of the zenith search antenna is also 2.4° in the horizontal plane. In the vertical plane the pattern is likewise a fan beam with an appreciable amount of cosecant-squared energy added on top. For determination of the energy levels at various vertical angles on both the surface and zenith search, reference may be made to the accompanying antenna patterns.

In the above discussion of antenna beam widths it should be borne in mind that all patterns discussed are "free space patterns". Beam widths, unless otherwise stated, are at 3 db down or half-power points.

One of the most difficult problems in the design of this antenna was the elimination of substantially all radiation from the zenith search antenna at vertical angles near 0° . This was desirable to avoid masking of aircraft by ship targets and sea clutter. The radiation in the 0° region is from 35 to 39 db down from the maximum energy point, which occurs at approximately 25° .

When the antenna is operating automatically the only indication of bearing is the angular position of the sweep on the VJ repeater, the reading being either true bearing (normal), or relative bearing, as determined by the switch on the Training Control Amplifier. The bearing may be read directly from a Navy type bearing repeater if one is connected to the system. In manual operation, the bearing may be read from the dial on the General Control Unit as well as from the VJ. Again the bearing is read in either true or relative, depending on the setting of the switch on the Training Control Amplifier. Thus the operator at the General Control Unit and IFF Coordinator-Range Indicator can determine bearing directly only when using manual control, and depends upon data from the VJ repeater or from a Navy type bearing repeater when automatic antenna training is used. To permit direct reading of relative bearing on the VJ and other repeaters when the system

is operating on true bearing, a ship's-head marker circuit is provided. This circuit produces a momentary brightening of the radial sweep at the bearing corresponding to the ship's heading. Relative bearing is read by noting the angle on the PPI between the marker flash and the signal trace. The marker flash may be eliminated, when desired, by a switch on the General Control Unit.

DETERMINATION OF RANGE

The PPI trace on the VJ starts with the main bang so that, as in all systems of this type, the distance from the center of the tube to the target echo is directly proportional to the distance from the antenna to the actual target. Target range, therefore, is estimated by noting the position of the echo on the screen with reference to the PPI range marks. On the range scope the distance of the signal from the start of the trace is also directly proportional to the distance of the target from the antenna, facilitating range determination by interpolation between the markings on the calibrated window of the range scope. This method of measuring range does not hold true when using expanded or delayed sweep. The range of targets falling between the fixed range marks on the VJ can be read by the use of the VJ range ring. This is accomplished by rotating the hand crank (with the range selector on the proper scale) until the movable range ring appearing on the PPI coincides with the signal to be ranged. When the ring is aligned with the signal, the range is read directly from the appropriate range counter. The most accurate ranging can be obtained by stopping the antenna on the target and adjusting the hand crank on the Range Indicator until the end of the variable range step on the range scope is aligned with the echo.

The range of the equipment varies primarily with the location, size and character of the target, the antenna height, the pulse width, and existing weather conditions. The 1.3-microsecond pulse will give considerably greater ranges than the 0.37 microsecond pulse. Because of the frequency band used (6500 Mc), the range would normally be considerably reduced in heavy storms. However, the high output power and antenna gain offset this loss so that the range is adequate even under severe weather conditions. Under average conditions, the equipment is capable of locating targets of fair size slightly beyond the optical horizon as seen from the antenna location.

Following compilation of the more important characteristics of the entire SG-6 system, including the VJ Repeater, should lead to a better understanding of the system.

SG-6 Radar System Performance Data

Transmitter Specifications:

Frequency	6500-Mc band
R-f source	Magnetron
R-f lines	Waveguide
Pulser	Triggered thyratron tube
R-f peak power	125 kw minimum, 285 kw maximum
Pulse rate	630 ±30 PPS
Pulse length	Choice of 0.37 or 1.3 microseconds

Receiver Specifications:

Type	Superheterodyne
Intermediate frequency	30 Mc ±1 Mc
Mixer	1N23B crystal
I-f bandwidth	2.5- or 5 Mc (relay controlled)
Local oscillator tuning	(Normal) Automatic frequency control
(Emergency)	Manual control
Special features	FTC, STC, IAVC, and HVP

Power Supply:

5 kva, 440/220/115 volts, 60 cycles, single phase.

Indication System:

Range Indicator	5-inch scope with normal A presentation. 5-inch scope with step on trace (M-type) Optional delayed sweep initiated by the VJ Repeater. Displaced IFF sweep. Range-ring output to VJ if desired.
Range	4, 20, 80 miles with range step and counters. 400-mile sweep with etched scale for range estimation.
Prime Use	IFF operation, ranging and observation of weak signals.
VJ Repeater (Delay Unit)	12-inch PPI scope.
Range	2, 4, 10, 20, 80, and 200 miles. Movable range-ring supplied from VJ or SG-6 Range Indicator.
Presentation	True bearing normally. Relative bearing if OSC fails and the SG-6 is switched over to relative bearing.
Prime Use	Search and coordination. Also used with other radars if selector switch is installed later.

Antenna Specifications:

Type	Dual assembly with two reflectors and two feeds. Slotted parabolic section for surface search. Clam-shaped for zenith search.
Antenna Beam (Surface Search)	Horizontal: 2.4°. Vertical: 16° fan beam, plus 12° cosecant-squared beam for a total above-horizon coverage of approximately 22°. Gain: 28-db. Polarization: Horizontal
Antenna Beam (Zenith Search)	Horizontal: 2.4°. Vertical: Combination of fan beam and cosecant-squared pattern. See radiation pattern for beam width. Gain: 28-db. Polarization: Horizontal
Rotation	Choice of 5 or 15 rpm in automatic. Slow speed in manual control.

X-Band Phenomenon

By LT. A. L. WITTEN,

Radar Officer, USS *Skirmish* (AM-303)

■ In the early part of March, 1946, this ship was cruising in waters approximately 130 miles south of the Gulf of Tehuantepec and about 80 miles offshore. A small echo was picked up at about 2000 yards on the SU radar, bearing 340 relative, at a range of 5000 yards. Coincident with this echo, the visual lookouts reported what was thought to be a flare on the same bearing. The ship changed course to head in the direction of the echo which had been picked up. As the range decreased, the echo took on the appearance of being a localized rain squall, then changed to give the appearance of very heavy sea return covering an area of about 2000 yards in azimuth and about 1500 yards in range. Sea conditions were ideal, with only a long gentle swell, water calm, and only a slight roll. As the range decreased still further, no target was visible on the surface or in the air, and no clouds were in evidence. The possibility of an unmarked shoal was discounted by a no-bottom indication of the fathometer.

As zero range on the echo was reached, the echo appeared to broaden and at that instant great globules of phosphorescence appeared to be rolling in the bow wave, giving out considerable light. This light was so intense that, without too much strain, a man could read a book on the fan tail of the ship. Engines were stopped, but no difference in the surface of the water could be observed as compared to the time before the target area was entered. As the ship passed through and beyond the area, the echo changed bearing to 180 and started increasing in range, which discounted the possibility of some object being detected on the second sweep of the radar. Searching of the area with the radar transmitter turned off momentarily caused the return to disappear, thereby showing that something in the phosphorescent area was actually reflecting the signals back to the receiver. The ship then turned and proceeded through the target area again, but on a course perpendicular to the previous passage. The same results were noted, bright objects in water, etc. As the ship left the target area and resumed its base course, the target was lost at about 3500 yards.

Bureau Comment: This is indeed a strange phenomenon. ELECTRON will welcome any additional information on this or any other extraordinary experiences of this nature.

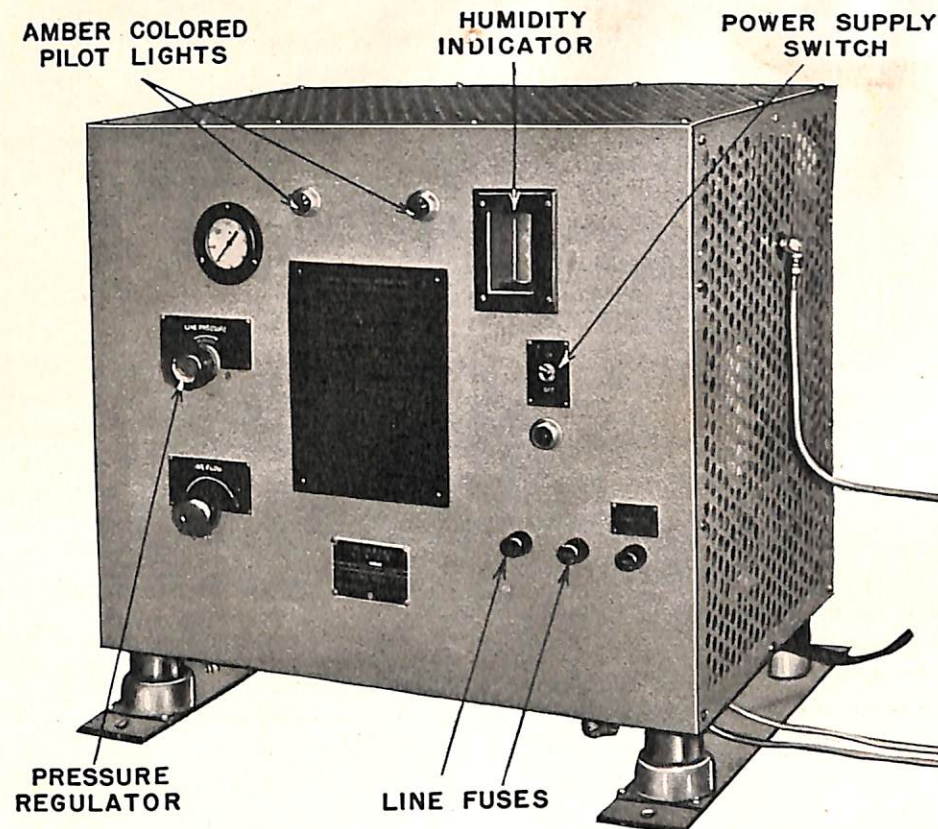

Front view of Model 2200/22, Navy Type CAKB-10AEK, Automatic Dehydrator, showing various controls and indicators.

Coax Dry-Air Requirements

■ A rigid coaxial or concentric transmission line consists of an inner cylindrical conductor, solid or tubular, and an outer tubular conductor. In lines for use at the lower frequencies (10 to 300 Mc) the inner conductor is held fixed at the center of the outer conductor by insulating spacers or beads placed at regular intervals. These spacers are made of Pyrex, polystyrene, or some similar material possessing good insulating properties and low losses at the operating frequency.

The advantages of coaxial lines are their low loss at the lower radar frequencies (10-300 Mc), which are primarily used for air search radars (SA, SC, SK, etc.), and the fact that the outer conductor completely shields the inner conductor and thus prevents radiation from the line. The outer conductor is maintained at zero potential and may be conveniently grounded at either or both ends, as well as at desired points along its length.

The disadvantages of rigid coaxial lines when compared to solid-dielectric lines are weight, cost, difficulty of installation, susceptibility to damage, and the fact

that the rigid lines must be kept free from moisture in order to prevent excessive high-voltage leakage or a complete breakdown between the inner and outer conductors at high voltages. Once an arc-over occurs, the entire line may require removal and replacement or a complete overhaul. Rigid lines were used on all the earlier air-search radar equipments such as the SA, SC, SK, and SR. Due to the many disadvantages and field difficulties encountered with this type of r-f line, a solid-dielectric line (RG-18/U) has been developed and is being used to replace the 15/8" (50-ohm) rigid lines on these equipments. However, this replacement does not affect the rigid line and coaxial rotary joint within the antenna proper.

In dry-air filled 15/8" coaxial transmission lines the critical breakdown voltage between the conductors (approximately 11,000 volts), rises approximately 60% as the relative humidity approaches 100% and liquid is not present. However, any decrease in temperature will then increase the relative humidity above 100% and the water vapor will precipitate out of the air in the form

of rain or frost. This precipitation will form on the bead insulators inside the line, thereby reducing by 50% the original voltage required for flash-over.

A typical example would occur in air completely saturated at 100°F, compressed to 50 p.s.i. (pounds per square inch), dehydrated, and then expanded to 8 p.s.i., entering the coaxial line at 60% relative humidity at a temperature slightly below 100°F. A change to cooler weather would cause the relative humidity of the air within the coax to increase to 100%, resulting in the precipitation of water droplets and eventual breakdown of the line. The breakdown may be only temporary or it may necessitate the removal of the entire line and possibly part or all of the antenna.

RELATIVE HUMIDITY

Air is said to be saturated when it contains all the moisture it will hold, it being remembered that the actual amount of moisture is dependent upon both the temperature and the pressure. Relative humidity is a measure of the actual amount of water vapor contained in a unit of air, expressed as a percent, relative to the maximum amount of water vapor that would be contained in the same unit of saturated air, under the same temperature and pressure conditions. The relative humidity of saturated air is therefore 100%. The cooling of air containing moisture causes the relative humidity to become greater as the air becomes cooler, finally reaching a temperature, called the dew point, at which the relative humidity becomes 100%. Any further lowering of the temperature causes the excess moisture, which can no longer be held by the air, to be precipitated. A good example is the dew found on the outside of a glass of cold water, caused by the fact that the water has cooled the glass to a temperature below the dew point of the surrounding air.

Sectional view of the pressure-reducing valve employed in the Model 2200/22 Automatic Dehydrator Unit.

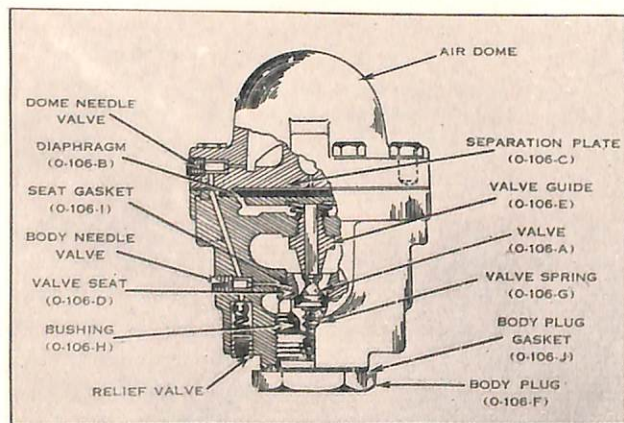

Several methods are being applied to supply dry air to coaxial transmission lines. One method used is to keep the line air-tight and furnish an opening for breathing during temperature changes. A protex plug containing silica gel is placed in the opening to dry all air entering the transmission line. This method requires the replacement of the protex plug when the silica gel crystals turn pink. Too often, replacement of this plug is neglected and saturated air is breathed into the coax as if no protex plug existed.

Another method is to use a dehydrator which consists of an air compressor, an automatic time-controlled dual-cylinder silica-gel air dryer, and an expansion valve. This method keeps the dew point down to about 4°F. However, it has the disadvantage of using rotating and moving mechanical parts.

Numerous types of dehydrators have been supplied to the Navy. The Model 2200 and the Model 22 dehydrators are the two principle ones in use today. The Model 2200 was procured on many equipment contracts, all supplied by The Communications Products Company. The Model 22 is an exact duplicate of the Model 2200, supplied by the Dielectric Products Company. The purpose of the dehydrator unit is to compress atmospheric air to approximately 50 P.S.I. (gauge), remove the liquid water and water vapor from the compressed air, and then expand the air to the desired coaxial line pressure. The advantages gained by compressing the air to a pressure above the coaxial line pressure are: To increase the relative humidity above 100% which will precipitate some of the moisture from the air and 100% relative humidity air will be passing through the drying chamber, insuring maximum efficiency from the silica gel. The relative humidity will further decrease upon expansion of the air into the line.

Sectional view of the Type 100 Expansion Dry Air Unit, showing the flow channel of the unit.

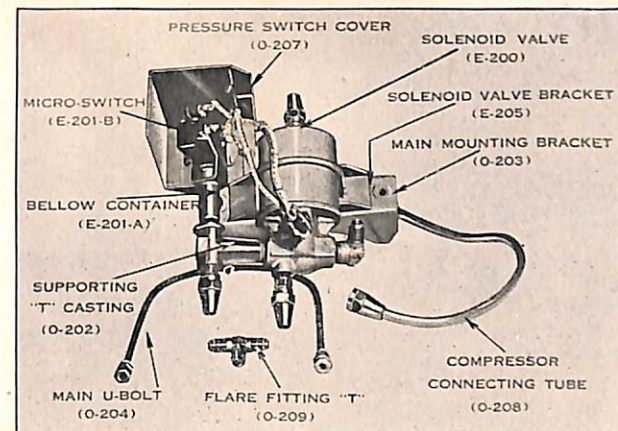
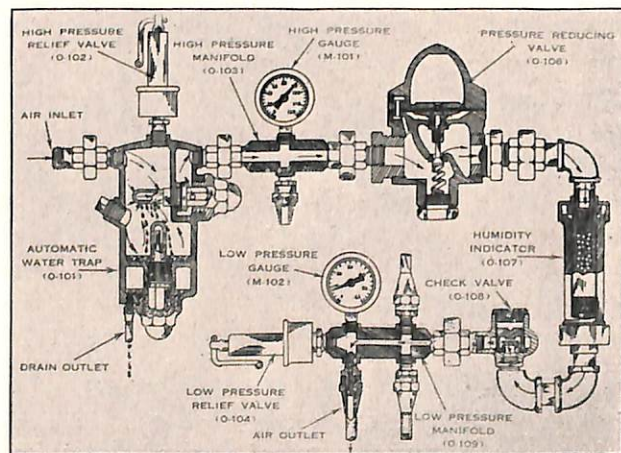

Type 100A Expansion Dry Air Adaptor Unit used in conjunction with Model 2200/22 Dehydrator Unit.

The principle difficulties reported on the Model 2200/22 dehydrators are as follows:

- (1) Unit runs continually due to sticky and corroded check valves.
- (2) Diaphragm worn out, dried out, cracked, ripped or porous.
- (3) Compressor crankshaft worn out, housing worn.
- (4) Improper seating of compressor head valve.
- (5) Compressor drive belt worn or slack.

In order that these difficulties could be corrected, material has been procured and distributed to the field as a kit. (See the Radar Maintenance Bulletin Supplement No. 10.) A routine monthly maintenance program should be inaugurated to check the electrical and mechanical operation of the unit by an experienced electrician and mechanic. NavShips 900,517 has been prepared to assist in the maintenance of these units.

In view of the numerous Model 2200/22 compressor failures, an improved air drying system (Type 100 Expansion Dry Air Unit) has been developed to use the ship's air supply, remove slugs of moisture and oil from the air, expand the air to a lower pressure, dry the air to a lower relative humidity, and then expand the air to the required coaxial line pressure. On those ships having a continuous low-pressure air supply the air compressor can be eliminated.

The expansion dry-air unit (Type 100) can be connected into any low-pressure (85 to 115 p.s.i.) air supply by the proper plumbing. It consists of a distribution shut-off valve, an automatic water trap, a high-pressure relief valve, high-pressure manifold, high-pressure gauge, pressure-reducing valve, humidity indicator, check valve, and a low-pressure manifold, pressure gauge, and low-pressure relief valve. All these units except the shut-off valve are mounted and neatly arranged on one

panel 12" high, 22 1/2" wide, and 5 1/4" deep. The panel can be mounted on either the bulkhead or the overhead. The distribution shut-off valve is necessary in case of trouble in the unit. Since it is a standard 1/4" gate or disk valve, it is not supplied with the unit.

The Liqui-Jector automatic water trap automatically and continuously removes and discharges liquid or aqueous solutions from compressed air lines by the action of two porous ceramic plugs, one of which allows only air to pass through, and the other allows only moisture to pass through. It will function irrespective of the state of subdivision of the liquid (mist, droplets, or slugs) but will not remove water vapor. This trap also serves as a filter to remove atmospheric dirt and finely divided solid particles picked up from the lines and compressor. Thus, air leaving the air outlet is free from all dust and dirt and will have a relative humidity less than 100%.

The operation of the Liqui-Jector automatic water trap utilizes the surface tension of the liquid. Phase separation and liquid ejection are accomplished by means of two controlled-porosity ceramic tubes, one inherently water repellent, the other water-permeable but air-impermeable. Compressed air entering the Liqui-Jector passes through the top ceramic tube where it is stripped of its aqueous solution contamination. The action is by coalescence of droplets on the surface of the tube, a coarse ceramic material with an average of 50,000 pore openings per square inch. Each one is so small (less than .0039 inches in diameter) that the resisting diaphragm-action of the surface tension of the water is greater than the pressure drop across the ceramic tube. The moisture then drops to the bottom of the Liqui-Jector and passes through the bottom ceramic tube to the outside atmosphere without loss of air pressure. This ceramic tube is constructed of micro-porous porcelain, with an average of 720 million pores per square inch, each less than .000039 inches in diameter. Being constantly wet by wick action, it constitutes a perfect air

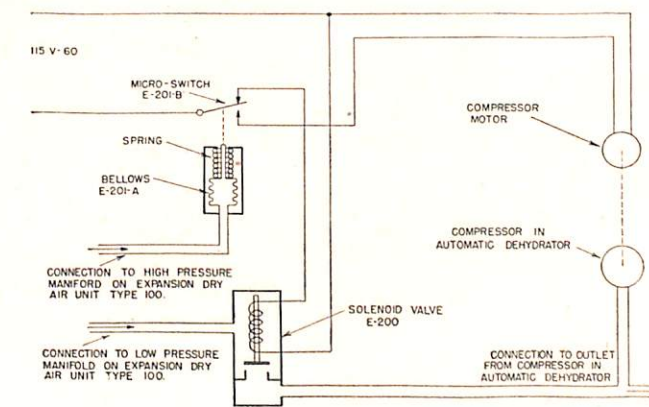

Combined air flow and circuit diagram of the Type 100A Expansion Dry Air Unit.

seal up to the rated limit working pressure of the unit. In order to insure wick capillarity action, it is necessary to prime the unit in operation. The Liqui-Jector Model A-1100-1 has a rated limit working pressure of 125 p.s.i., a water ejection rate of 92 cubic inches per 24 hour period at rated pressure, and a line pressure drop of less than 1 ounce per square inch for the radar coaxial maximum air requirements.

The high-pressure relief valve will relieve the pressure on the water trap and prevent damage to the air seal formed by the moisture in the pores of the water ejector element in case of a surge in the line pressure.

The pressure reducing valve is a diaphragm-operated pressure regulator. The diaphragm position governs the valve opening to keep the reduced pressure constant. In place of the conventional spring, compressed air is used to load the diaphragm. This diaphragm loading is accomplished by bleeding air from the line through the two loading needle valves. The loading needle valves are used to seal off or trap the pressure in the air dome for loading.

The humidity indicator consists of a transparent plastic tube filled with silica gel. The silica gel has been treated with a chemical (cobalt salts) so that it will be blue in color when the air is perfectly dry and will be pink in color when the relative humidity of the air rises above 40%. The tube is painted with pink enamel to serve as a guide. The check valve has been provided to prevent a reverse directional flow of air through the pressure reducing valve.

Since the air leaving the Liqui-Jector automatic water trap under the most adverse conditions will probably be 100% relative humidity, the air when expanded from 100 p.s.i. (by the reducing valve) will have a relative humidity of approximately 50% at 60°F. The dew point of this air would be approximately 40°F. If the atmospheric temperature drops below 40°F. water is sure to precipitate out of the air. Therefore, this information suggests that further drying is necessary to meet the demands of extreme conditions. Two alternatives have been considered to decrease the relative humidity of the air entering the coax. First, the use of present Model 2200/22 dehydrator time-controlled automatic air drying cylinders, and second, the use of a separate independent automatic air dryer.

The Model 100 expansion dry air unit may be connected into the Model 2200/22 compressor by adding a new expansion dry air adaptor unit. This unit consists primarily of a small solenoid valve and a pressure switch mounted on the same bracket. This bracket is in the form of a U-bolt, and mounts on the reserve air chamber within the Model 2200/22 automatic dehydrator. It is described in Model 2200/22 Field Change No. 4.

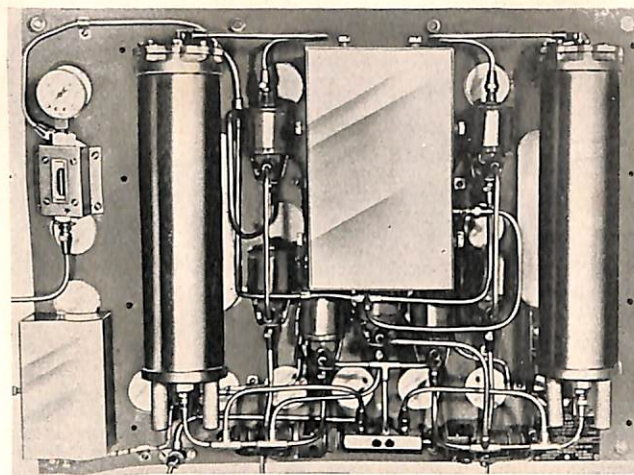

Automatic Air Dryer, Type CAKB-10631, front view with protective cover removed.

The solenoid valve is built so that it is normally closed. When electric power is applied to the valve solenoid the spring tension of the valve is overcome and the valve opens and remains open as long as power is applied. The power applied to the valve solenoid is controlled by a single-pole double-throw bellows-controlled switch. As long as the ship's line pressure remains above 70 p.s.i. the bellows-controlled switch will retain power on the valve solenoid. The operation of this switch also completes the circuit to the dehydrator compressor motor. The compressor will now supply all the air requirements as long as the ship's air supply is below 70 p.s.i.

The automatic air dryer within the Model 2200/22 dehydrator dries the air from 50% relative humidity to 2% relative humidity, which has a dew point of 4°F. The automatic air dryer contains two cylinders of silica gel and a timing mechanism to control the flow of air through the cylinders such that while one cylinder is drying the air being supplied to the antenna, the other cylinder is being dried out by heating the moisture into steam and passing air through it to carry the steam to the outer atmosphere.

An independent Model 10631 automatic air dryer has been developed that can be directly connected to the Model 100 expansion dry air unit and which will accomplish the same thing as the automatic air dryer in the Model 2200/22 dehydrators. The independent Model 10631 automatic air dryer consists of two silica gel cylinders, a timing mechanism to control the flow of air, a humidity indicator, and a pressure gauge mounted on a panel 27 $\frac{3}{4}$ " wide, 20 $\frac{1}{4}$ " high and 6" deep.

The purpose of the Model 10631 automatic dryer is to receive the wet air from the Model 100 expansion dry air unit and condition it to a relative humidity of 2% for use in air-filled coaxial transmission lines where frost and moisture must be kept out.

When the Model 100 expansion dry air unit is used with the Model 10631 automatic air dryer, the pressure reducing valve reduces the 115-lb. ship's air line pressure down to 5 or 10 lbs. by making the proper adjustments to the dome needle valve and body needle valve on the Model 100 expansion dry air unit.

It is pointed out that this project uses the Model 100 expansion dry air unit primarily as a reducing valve for the purpose of reducing the ship's air supply to a usable value. Since it is wet air, two methods are provided to dry the air, the automatic dryer within the Model 2200/22 dehydrators and also an independent automatic air drying unit (Model 10631) which has been developed to provide the same function as the Model 2200/22 except that no provisions have been made for compression. These units are now available in Naval supply depots.

• • •

WATCH YOUR KILOCYCLES

Navy radio securities activities have obtained frequency measurements which indicate that frequency tolerance violations are increasing. It must again be emphasized that all transmitting stations must maintain their frequencies within the authorized limits. The importance of this action cannot be over-emphasized. The continuance of these violations may well result in the loss of the assigned frequencies, as frequency allocations are becoming increasingly limited.

This off-frequency operation is occasionally caused by faulty equipment, but most frequently arises due to negligence or lack of interest. For this reason it is imperative that all personnel concerned make a special effort to keep their transmitters on frequency. The frequency measuring equipment aboard ship may not be as accurate as that used in laboratories, but it can be operated well within the established tolerance limits. Its frequent use will prove of great assistance in combatting this problem. The following procedure is in order:

1. When time does not permit pre-checking the transmitter frequency, it should be checked as soon as possible after setting up on a new frequency.
2. Immediately report any erratic or defective frequency to the technician responsible for the maintenance of electronic equipment.
3. Insure that all personnel are capable of correct operation of frequency measuring equipment and are aware of the consequences of off-frequency operation.
4. Where practicable the frequency measuring equipment should be checked against the standard frequency transmissions from the Bureau of Standards at least once

a week. These transmissions are usually continuous on 5 or 10 megacycles, and during daylight hours at Washington, D. C., on 15 megacycles.

Additional information on setting up and loading transmitters may be found in several articles contained in the Communication Equipment Maintenance Bulletin, and all personnel concerned should become thoroughly familiar with their contents.



TELETYPE MODIFICATION

This modification provides a *receiving-only* control circuit for simplex operation with the No. 19 teletype set when used in conjunction with the BD-100 Switchboard. The modified circuit will shut off the associated reperforator during transmission from the Model 19 tape transmitter and automatically restore it to a receiving condition when the transmission ends by controlling either the reperforator motor or signal circuit. Details for additional wiring and connections in both the a-c and d-c operated release magnet circuits are given in the figure. Step-by-step procedure for making the change is as follows:

First method: Control of Reperforator Motor (Applicable to any reperforator).

- (A) If Transmitter distributor has an a-c operated release magnet circuit.
 1. Remove strap between terminals 38 and 42 of terminal block *B* and connect to these terminals the coil winding of an added a-c or universal power-type relay.
 2. Remove strap between terminals 30 and 40 of terminal block *A* and connect to these terminals the normally closed (contacts closed when relay coil is de-energized) contacts of the added relay. These contacts are designated *A* and *B* in the figure.
- (B) If Transmitter distributor has a d-c operated release magnet circuit.

1. A motor control relay assembly (part No. 72484) will be found in the left-rear corner of the motor base of the Type 15 printer. This assembly is not being used, so it can be wired in for this modification in either its present location or in some convenient place under the 19-set table.
2. Remove strap between terminals 35 and 39 of terminal block B and connect to these terminals the coil winding of the added relay.
3. Remove strap between terminals 30 and 40 of terminal block A and connect to these terminals the normally closed contacts of the added relay.

Second method: Control of reperforator signal circuit (Applicable only to reperforators equipped with polar relays).

(A) A-c operated circuit.

1. Same as Method #1. Step (A)1.
2. Connect T and M terminals of the No. 225 relay in the reperforator to the normally-open

contacts (designated B and C) of the added relay as shown in the sketch.

(B) D-c operated circuit.

1. Same as Method #1, step (B)2.
2. Connect T and M terminals of the 255A relay in reperforator to the normally-open (designated B and C) contacts of the added relay as shown in the sketch.

The added relay for this modification is inserted in the transmitter-distributor release-magnet circuit. It is energized while sending from the tape transmitter, and thereby controls the operation of the reperforator by providing (by the first method) a power cut-off in the motor circuit through its normally-closed contacts which open when the relay is energized or, (by the second method) by providing a means for shorting the tongue and marking contacts of the 225A relay in the reperforator by means of the normally-open contacts which close when relay is energized. Either action disables the reperforator during the sending period.

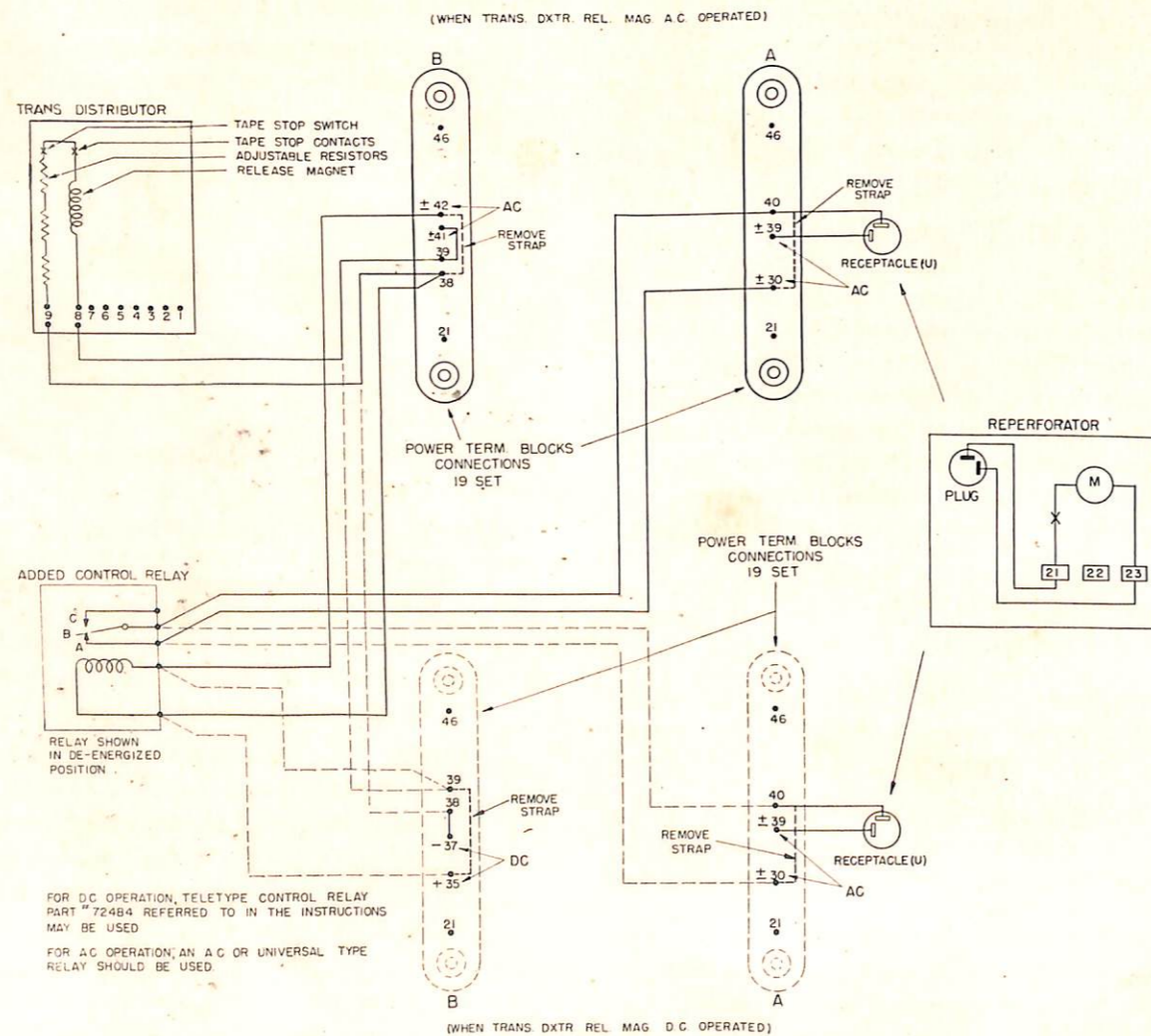

ANTENNAS: BEAM WIDTH

For most radar applications, directional antennas are used to determine the azimuth position of the target and to concentrate the energy in the desired direction. The gain of a directional antenna and the way in which it affects the range performance were discussed in Section II. For direction finding, the angular width of the antenna pattern is also an important item. It is customary to define arbitrarily the width of the antenna pattern W as the angle between the two half-power points, as indicated on figure 53. In this diagram the

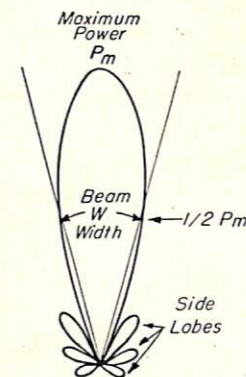

FIGURE 53—Antenna pattern.

radial distance from the origin represents the power radiated in that direction. In addition to the main lobe there are a number of side lobes indicated. Where the beam is formed by some type of reflector or by an area covered with properly phased radiators, the approximate beamwidth is given by

$$W = 2.1 (\lambda/D) \quad (20)$$

where W is the angular beamwidth in degrees, λ is the wavelength in centimeters, and D is the distance across the effective part of the antenna in feet. Thus a high-frequency transmitter and a wide antenna will give the narrowest beam. The intensity of the side lobes is very sensitive to details of the geometry of the antenna, but the angular position of these lobes with respect to the main lobe will be found to vary directly with the beamwidth of the main lobe when λ or D is changed.

PARABOLIC REFLECTOR

At high frequencies, the most common method for obtaining a focused beam is to place a radiating dipole at the focus of a paraboloid of revolution. This will form a radio beam in the same way that a searchlight reflector forms a beam of light. Paraboloids as large as 60 feet in diameter have been built for this purpose, but none larger than 30 feet were used for operations during the war.

DIPOLE ARRAYS

Another commonly used method for concentrating radio power is based on wave reinforcement. If we have a row of radiators spaced a distance d apart, as shown in figure 54, and all are radiating in phase, the radiations

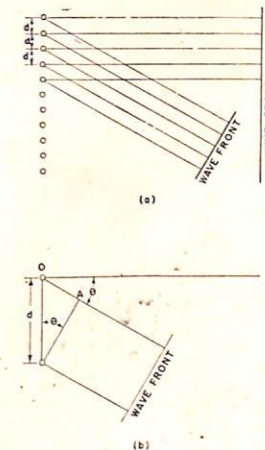

FIGURE 54—Diffraction antenna.

from them obviously will be in phase on a line in space parallel to the source because the paths are all equal in length. As in an optical grating, the radiation may also be in phase at an angle θ from the normal. In figure 54(b), the path difference OA between adjacent dipoles is given by

$$OA = d \sin \theta.$$

When OA is any whole number of wavelengths, the energies from each source will again be in phase, thereby

forming another wave front. Hence the energy will be concentrated in directions given by

$$\sin \theta = n\lambda/d \quad (21)$$

where n is a whole number and λ is the wavelength. Between the angles given by (21) there will be some small lobes caused by reinforcement between, say, every third or every fifth source; but these will be small because the intermediate sources will largely cancel each other. If $n\lambda/d$ is greater than unity, only one wave front can exist. Therefore, if d is chosen so that d is greater than one, only the lobe for $n=0$ will exist and the energy will go out perpendicular to the array of sources. The beamwidth will be given by (20) when D is the length of the array.

The 10-centimeter ultraportable beacon known as "Bups" uses an antenna of this type. Since this beacon is used to mark points on the ground, it is built to be nondirectional in azimuth; but a reasonable antenna gain is achieved by concentrating the energy at low angles. Figure 55 shows the construction and a section through the lobe pattern.

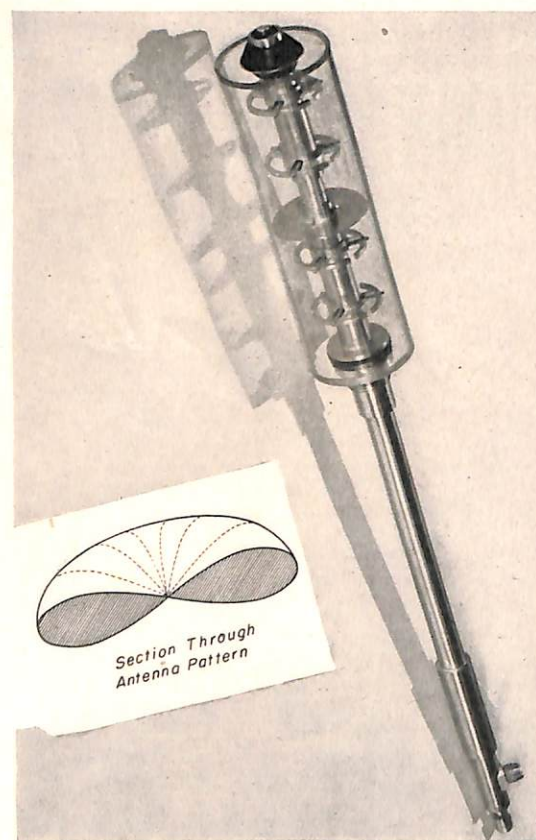

FIGURE 55—"Bups" antenna.

Where it is desired to concentrate the energy in one direction, several of these arrays can be placed side by side to obtain reinforcement in both the vertical and horizontal directions. Figure 56 shows the construction of the SCR-270 antenna for which the radiators are

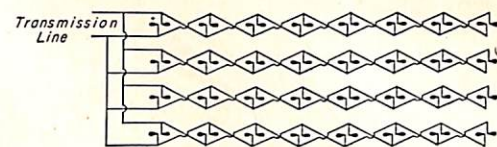

FIGURE 56—Dipole array, SCR-270 antenna.

dipoles. In order to keep the spacing d at the desired value and still preserve the phase relationship without unnecessary lengths of transmission line, it is advantageous to reverse the polarity of the line between the dipoles as shown. The line lengths are chosen to place the dipoles a half wavelength apart along the transmission line, but the dipoles themselves are driven in phase by reversing connections on alternate dipoles. Back radiation is prevented by placing a wire screen a half wavelength behind this dipole array. The reflected energy is then in phase with transmitted energy at the dipole. All of the early search-radar sets used this type of antenna.

CYLINDRICAL REFLECTORS

Another method of concentrating the power from a line of sources is to use a parabolic cylinder for a reflector, as shown in figure 57. The array causes concentration of the energy in the direction of the axis of the cylinder, while the reflector focuses the energy in the direction at right angles. This type of antenna is used on the MEW(AN/CPS-1), GCA(AN/MPN-1), and Eagle (AN/APQ-7). At the high frequencies used by these

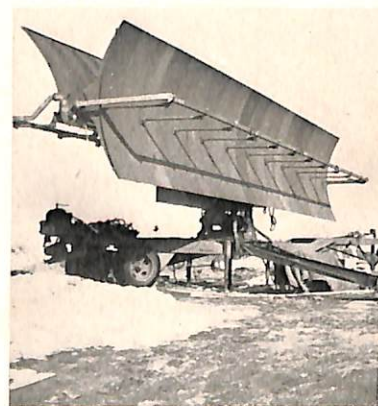

FIGURE 57—AN/CPS-1 antenna.

sets the number of dipoles along the array may be a hundred or more. It is, therefore, more economical to use a reflector than a series of arrays to obtain focusing in the other direction. This type of antenna finds its main application where a flat thin beam is required. Slots of the proper length and size across the wide face of a wave guide may be used instead of dipoles as radiators.

In the GCA and Eagle antennas the beam is changed in direction by altering the phase of the energy reaching

the dipoles. If a variable-frequency transmitter were available, the phase of the dipoles placed along the line would vary with the frequency. This phase change would then alter the direction of the beam of figure 54(b), because the condition of reinforcement would require the phase difference S plus $d \sin \theta$ to be a whole wave-length. This variation of beam position with frequency may be a disadvantage in an array used for accurate angle measurements.

Since variable-frequency transmitters are not available in the microwave region, the variation of wavelength in a wave guide with the dimension B in figure

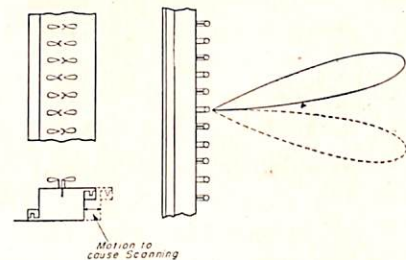

FIGURE 58—"Eagle" antenna.

30 may be used to shift the phase. When the two sections of guide shown in figure 58(a) are moved back and forth with the sides kept parallel, the beam scans back and forth as indicated in figure 58(b). The dipoles are driven through short lengths of coaxial line, and the energy is coupled from the guide by using the proper length of wire conductor protruding into the guide as a probe. As in the case of the SCR-270, the dipoles are about a half wave apart but are fed in phase by turning alternate dipoles 180 degrees to interchange the positions of the wings fed by the inner and outer conductors of the coaxial line.

HORNS

Another method of forming a radio beam is to use a horn which is properly shaped so that the radiation which reaches the mouth of the horn is in phase at all points on the wave front. Horns are likely to be bulky, compared with other antenna types, so are seldom used for forming the final beam. For example, a Japanese 10-centimeter set uses a horn about 5 feet long to obtain an effective antenna aperture of 30 inches. The same result could be obtained with a 30-inch-diameter paraboloid about 10 inches deep. Horns are, however, very commonly used in place of dipoles to illuminate a reflector. Horn feeds are best adapted to wave-guide lines while dipoles are more easily adapted to coaxial and parallel-wire transmission lines.

LENSES

Presumably, radio energy could also be focused by means of lenses made of a material such as plastic

or glass which is transparent at the transmitter frequency. However, it is usually impractical to handle large blocks of such materials. The property which makes a lens or prism change the direction of a light beam is a difference in wave velocity from that in the surrounding medium. In a prism the part of the wave which has traveled the farthest in glass will lag the most, thereby bending the light beam toward the thick part

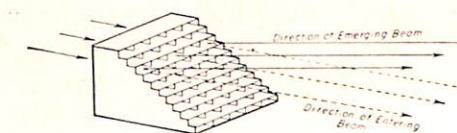

FIGURE 59—Wave-guide prism.

of the prism. Since the velocity of a wave in a wave guide is greater than that in free space, it is possible to bend a radio beam by a prism made of a stack of guides, as shown in figure 59. Here the beam will be bent toward the narrow part of the prism because the wave gets ahead in traveling through the guide. By proper choice of the lengths of equal-area wave guides, a lens action may be obtained. To form a converging beam, such a lens will be thicker on the rim than at the center. Another method is to make the lengths of guide constant but to vary the width of the guide to alter the velocity over the face of the lens. Lens antennas are most useful in applications where the feed mechanism is large and would block out a large fraction of a reflector.

RAPID-SCAN DEVICES

When radar is used to locate objects whose position is unknown, it is necessary to scan or sweep out an area. This may obviously be done by turning the whole antenna system to look in the desired direction, but may not be practical if rapid scanning is desired. Therefore, a number of rapid-scan devices have been developed. Although these are frequently called "electrical scans," most of them depend on moving mechanical parts.

One type of rapid-scan mechanism is that used in the GCA and Eagle sets as described earlier.

Another type is used in the SCR-598 and operates with a "Schmidt-camera" type of focusing system. Since a complete description of this set has been given, it will not be described here.

A number of scanning devices have been built on the principle that moving the feed off the axis of a lens or paraboloid will cause the beam to swing off axis on the opposite side. Since the gain of the antenna decreases rapidly when the feed is far off axis, the angle of scan obtainable by this method is usually limited to a few beamwidths on either side of center. The obvious meth-

od is to oscillate the feed about the axis. Although one large radar set used an oscillating feed at several oscillations per second, vibration presents a serious mechanical problem which can be avoided by rotary motion. The "Robinson feed" offers one solution. If the antenna is fed by a thin horn in which the feed is moved up and down along the opening, as indicated in figure 60(a), the beam will oscillate as just described, the horn having little effect. The input end of the horn is now rolled into a circle without bending the other end, as indicated in figure 60(b), and the feed is moved in a circular path. The antenna scan remains the same as for that in figure 60(a), but the mechanism for driving the feed will be much simpler.

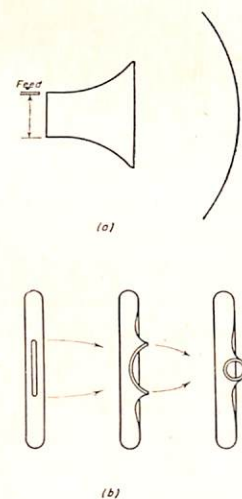

FIGURE 60—Robinson feed.

The "Foster scanner" uses a line source of radiation obtained by feeding a parabolic "pillbox," as shown in figure 61(a). The polarization is across the thin dimension so that the opening acts as a very wide wave guide. When this pillbox is placed in front of a cylindrical reflector, as shown in figure 61(a), a beam will be formed, the pillbox focusing in the vertical and the reflector in the horizontal direction. Rocking the pillbox up and down causes the reflected beam from the cylinder to scan up and down. In order to scan with a purely rotary motion the pillbox is bent to fit inside a cone the large end of which is shown in figure 61(b). The power is reflected to the outside of this cone by two mirrors at 45 degrees to the tangent line as shown. A second cone is placed outside this cone and carries another mirror which reflects the power trapped between the two cones out through a slot. The space between the two cones acts as a very wide wave guide, so that the wave velocity is essentially that of free space. As may be seen from figure 61(d), the power in leaving the pillbox will have to travel farther to reach the slot at the large end of the cone than at the small end. This is equivalent to tipping

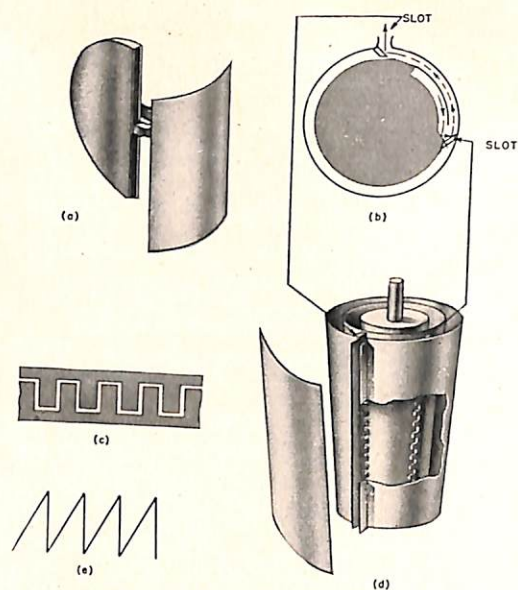

FIGURE 61—Foster scanner.

the top of the pillbox away from the reflector in figure 61(a). Now if the inner cone is rotated, the difference in distance traveled by the power at the two ends of the cone will change, thereby simulating a rocking of the pillbox in figure 61(a). In order to allow the inner and outer cone mirrors to pass, they are built as teeth (see figure 61(c) spaced close enough to prevent leakage of power. Since the difference at the two ends approaches zero as the teeth meet and suddenly jumps to a maximum after they pass, the scan will be as shown in figure 61(e).

SCAN PROCEDURES

Because effective search for a target can be made only when the whole area of interest is scanned without gaps, the search must be carried out in some methodical manner. When the target is a ship, the problem is simply one of sweeping a horizontal beam over the surface of the water; but when the target is an aircraft, the search must also cover the vertical dimension.

For limited solid-angle search the spiral scan, as in figure 62(a), and the saw-tooth scan, as in figure 62(b), may be used to cover the volume of space by a beam which does not fill either dimension of the solid angle. In order to insure solid coverage, the separation between turns of the spiral or sweeps of the saw tooth should be no more than half a beamwidth. This means that the rate of radial motion of the spiral scan must have a fixed relationship to the circular rate, and that the horizontal motion of the saw tooth as shown must be related to the vertical-scan speed. Because it is simpler to visualize the mechanical system, let us confine our attention to the saw tooth for the moment. Let us assume vertical motion is generated by rocking the antenna in elevation and horizontal motion by rotating it in azimuth. Also let

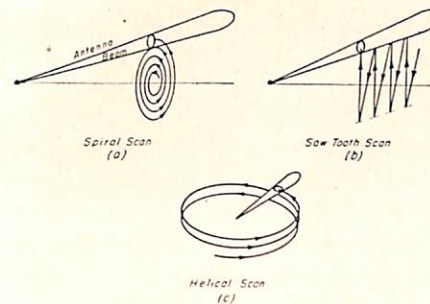

FIGURE 62—Types of scans.

us take the radar beamwidth as 4 degrees. Then the antenna can move only 2 degrees in azimuth for one complete vertical oscillation if the coverage requirement of an overlap of at least half a beamwidth is to be met at all points. Now if the antenna is to search once over a 90-degree azimuth sector in 30 seconds, 45 complete vertical oscillations will be required in this time, or 1.5 oscillations per second. Although this azimuth scan rate is low for aircraft search, the vertical-scan rate is high enough to present a considerable mechanical problem if the whole antenna is rocked; hence the requirement for rapid-scan devices.

Where the azimuth search angle is 360 degrees, the saw-tooth scan may be used; but the spiral scan is impracticable. In its place a helical scan is used. In the helical scan the antenna tilts one-half beamwidth in elevation for each complete revolution in azimuth. Normally, on 360-degree search, the scan is not carried above 30 degrees in the vertical direction because a large fraction of the search time would be spent in this region which represents an extremely small fraction of the volume of space in which aircraft might be found. Where search at high angle is required, a separate low-powered set is more economical.

SHAPED BEAMS

Another method of obtaining solid search from the horizon to a given elevation angle is to use a beam which fills this angle and to scan only in azimuth by rotating the antenna structure. The beamwidth in the vertical direction depends on the vertical aperture of the antenna and the wavelength (see (20)). From (5) we see that, where the same antenna is used for transmitting and receiving, the performance of the set for a given vertical beamwidth will be independent of frequency if all other factors are held constant. However, at the higher frequencies the azimuth beamwidth will be narrower and the resolution will be better. Also, the antenna will be smaller in the vertical dimension. If both sets make use of ground reflection to obtain increased range, these conclusions still hold; but the coverage will have gaps due to the lobes. As was discussed previously, these gaps may be a serious handicap in tracking aircraft.

Since aircraft at present do not often fly above 40,000 feet, obtaining high-angle coverage, as indicated by the dotted line in figure 63, would be expensive because the power in the beam is much greater than is required to insure coverage up to 40,000 feet. The antenna pattern indicated by the solid line would be much more economical because only a small extra coverage is provided to insure tracking at 40,000 feet. Antennas which give a constant-altitude top coverage are called "cosecant-squared antennas" because the power in the antenna pattern on one-way transmission must fall off as the square of the cosecant of the elevation angle. This same type of pattern is needed to give constant illumination on the ground over a large vertical angle measured

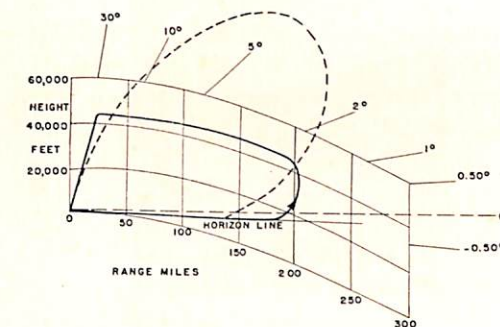

FIGURE 63—Cosecant-squared beam.

downward from an aircraft. Shaping of the beam can be accomplished by shaping the reflector or lens to throw the energy in the proper directions. To a reasonably good first approximation, the reflector shape may be visualized by imagining sections of a parabolic reflector properly tilted to give a series of beams which overlap to form the desired beam. After these are chosen with due regard to the gain and the beamwidth needed for each section and are pieced together, the reflector will be made up of several parabolic sections which do not join smoothly. A smooth curve joining the centers of these sections will be very nearly the shape required for the final beam. A second method is to use a paraboloidal reflector with several radiators arranged in a line perpendicular to the axis. A fairly good approximation to the desired result will be obtained if these dipoles or horns are placed so that the beams which they produce independently will add to make the final beam and the relative power distribution is properly adjusted. Some adjustment of phase and amplitude may be necessary to smooth out the pattern. These sources can be fed from the same transmitter and may be placed in parallel along a transmission line. On the other hand, if insufficient power is available to obtain the coverage with one transmitter, the sources can be fed on separate frequencies.

Since the radiation pattern from an antenna is too wide to determine accurately the angular position of the target, lobe switching is commonly used for precise angle measurements. If the phase between dipoles in an array or the position of the feed in a reflector is alternated between two values, the antenna lobe will oscillate between two positions, as shown in figure 64. A target on the line OA will give equal signals from the two lobes, while one on the line OB will give a much stronger signal from the right lobe. The target angle is read from the antenna position when the two signals are matched. An angular accuracy of a tenth of a degree is obtainable by this method.

A conical scan is convenient where lobe matching is required in both azimuth and elevation. If the antenna feed is placed slightly off axis and is rotated in a circle about the axis of a paraboloid, the antenna-beam center will rotate on a cone centered about the axis. Equalizing the signals for all positions of this feed establishes the line of sight to the target.

INDICATORS: TYPES OF INDICATION

The presentation of the radar signal must be interpreted readily by the operator, and a great many types of signal indicators have been developed in an effort to improve the speed, accuracy, and ease of data interpretation. However, only the types most commonly used will be discussed here.



FIGURE 64—Lobe switching.

The standard cathode-ray oscilloscope in which the signal appears as a deflection on a time-base sweep is called an "A-scan." In cases where the range scale or time-base sweep is too compressed, a small portion of the A-scan may be expanded by starting the sweep some time after the transmitter has fired. Although this expanded sweep is essentially an A-scan, it has been named an "R-scan." Another method of obtaining a long trace on a small tube is to bend the A-sweep into a circle to form a "J-scan." Examples of these presentations are shown in figure 65. The general fuzz which causes the time base to appear broad is the noise from the receiver input.

These indicators usually employ electrostatically de-

flected cathode-ray tubes with a nonpersistent fluorescent screen.

In another group of indicators the signal is presented as an intensity brightening. The "B-scan" displays range against azimuth angle in rectangular co-ordinates as shown in figure 65(c). The "C-scan" presents azimuth against elevation. In the PPI (plan-position indicator), azimuth angle and range appear in their true relationship as polar co-ordinates. Hence, this indicator presents a map picture with only a small distortion introduced by the use of slant range instead of ground range. For height finders, a variety of indicators presenting range against height have been built. This type of indicator is known as RHI (range-height indicator). Most of the intensity-modulated indicators use magnetically deflected cathode-ray tubes with a persistent screen which glows for several seconds after the beam passes over the target.

RANGE CIRCUITS

The basic range-sweep circuit is shown in figure 66(a). A square-wave generator synchronized with the transmitter operates an electronic switch which controls a saw-tooth generator as indicated by the wave forms in figure 66(c). This square wave is also applied to the cathode-ray tube as a blanking voltage to cut off the electron beam during the return trace. The blanking voltage may be applied to the cathode, grid, or first anode of the indicator tube, provided the amplitude and sign of the voltage wave are properly chosen. Although the square wave may be generated by any of the methods described in Section V, the multivibrator is the most commonly used in the newer types of radar.

(A.) *Saw-tooth generators:* The timing or range sweep is a saw-tooth wave form generated by charging or discharging a capacitor. If the capacitor is charged through a resistor, the saw tooth is nonlinear and results in a range scale which is compressed at the long-range end. If, as in the usual cathode-ray oscilloscope, only a small fraction of the charging curve is used, the non-linearity is not particularly noticeable. Still further improvement may be made in the wave form by using a nonlinear amplifier which produces distortion in the proper direction to straighten the saw tooth. Another method for obtaining a linear saw tooth is to charge or discharge a capacitor at constant current. Since the plate current of a pentode is very nearly constant over a wide range of plate voltage, the circuit shown in figure 66(b) will give an excellent range sweep.

Constant-current charging can be even more closely approximated by using the circuit in figure 66(d). When the switch tube is turned off, the capacitor C_1 begins to charge through the resistor R . This rise in voltage carries

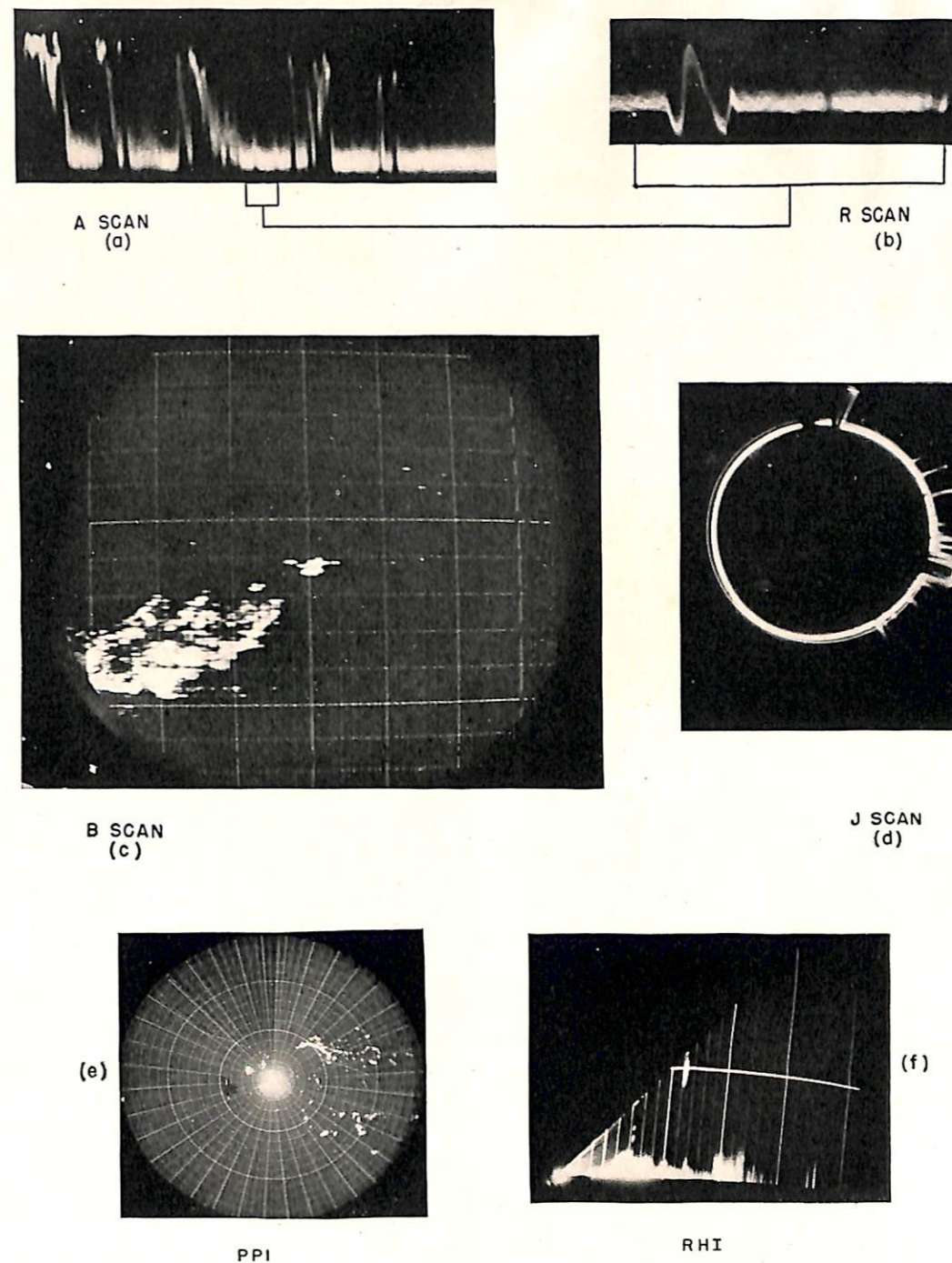

FIGURE 65—Types of indicators.

the grid of the cathode follower in a positive direction, thereby raising the voltage at A by very nearly the same amount. If the capacitor C_2 is very much larger than C_1 , C_2 will not become appreciably discharged during the charging of C_1 . Hence the voltage across C_2 may be considered to remain constant. Then, as the voltage of point A rises, the voltage point B is carried positive by the same amount, thus maintaining essentially constant current through R . During this process C_2 is acting as the source of current, and the diode is cut off

by the rise in voltage at point B .

(B.) *Sweep-delay circuits:* Where a section of the range scale is to be enlarged as in an R-scope or a "delayed B-scan," a time-delay circuit is placed between the source of synchronizing voltage and the square-wave generator. The remainder of the circuit is as shown in figure 66(a), in which the circuit constants are adjusted to produce a faster sweep than in an indicator which is to present a long-range scale. Several adjustable range-delay devices have been used for this purpose.

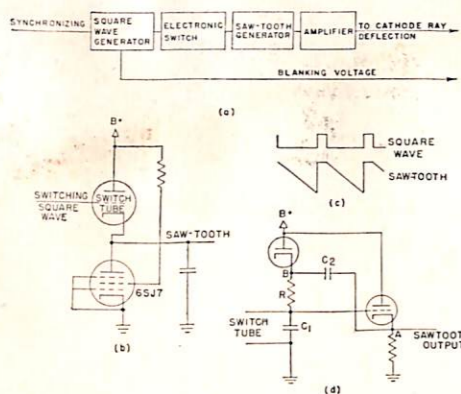

FIGURE 66—Range-sweep circuit.

(1) *Multivibrators:* The back edge of a multivibrator square pulse may be used to trigger the circuit of figure 66(a). If this multivibrator is triggered by the transmitter, the time delay will be equal to the "flip-over time," as determined by R_1 and C_1 in figure 11, and may be readily adjusted by making R_1 a variable resistance. The width of the square wave does not vary linearly with the value of R_1 in this type of multivibrator; therefore, a "cathode-coupled multivibrator" is preferable for this purpose. Figure 67 shows two types of cathode-coupled multivibrators for which the width of the square wave varies linearly with the value of R_1 .

In both of these circuits, tube T_1 is initially biased to cutoff by the voltage across the cathode resistor, this voltage being maintained by the current through T_2 . The mechanism of operation of these circuits is illustrated by the wave-form diagrams. If the voltage ($B+$) is very well filtered, the time "jitter" in the sweep cir-

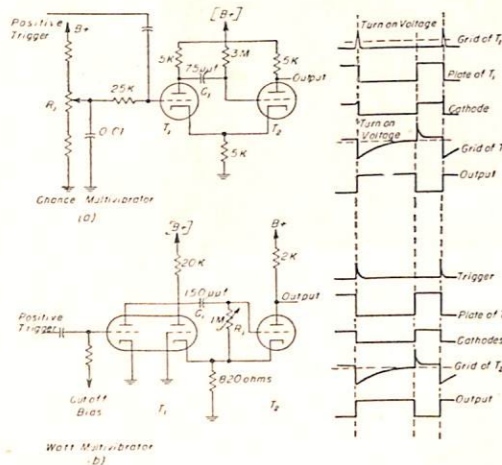

FIGURE 67—Cathode-coupled multivibrators.

cuit due to variations in the width of the multivibrator output can be reduced to less than 0.1 mic.osecond. When the width of the multivibrator output used for the time delay varies by more than the transmitter pulse length, signals on successive sweeps will not coincide on the tube face; and a loss in definition of the radar pic-

ture will result. It is, therefore, important to provide additional filtering for the ($B+$) voltage and is desirable to use a VR tube to aid in holding this voltage constant.

(2) *Saw-tooth delay:* A second method of delaying a sweep is illustrated in figure 68. A linear saw tooth is is

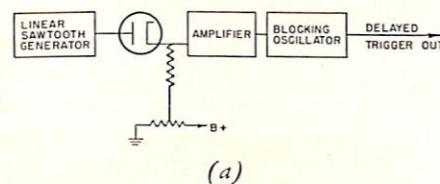

FIGURE 68—Saw-tooth delay circuit.

started at the instant the transmitter pulse is sent out. When this saw tooth reaches the bias voltage on the diode, current will flow, thereby raising the grid voltage in the amplifier. This voltage change may then be developed into a trigger by tripping a blocking oscillator or may be amplified to the point where it is sufficient to start the multivibrator used to generate the delayed sweep. The time delay between the transmitter pulse and the trigger generated by this circuit may be adjusted by the setting of a linear bias potentiometer.

(3) *Phantastron:* The "phantastron" shown in figure 69 offers a third method for obtaining the required time delay. The second control grid G_3 is biased to cutoff, a process which forces all of the current to go to the first screen grid G_2 . If the cathode is about 40 volts above ground, G_3 should be at about 25 volts. Neglecting the diode for the moment, one sees that a positive pulse applied to G_3 allows the plate to draw current and, consequently pulls the first control grid to a lower voltage because of the coupling capacitor C . This action drops the cathode voltage to near zero so that G_3 no longer cuts off the plate current. As the charge leaks from the capacitor C , the current through the tube increases because the first grid becomes more positive. The plate voltage then drops below the initial turn-on value and tends to prevent the grid voltage from rising. The net result is a downward drift of the plate voltage and an upward drift of the first grid, as indicated in figure 69(b). Eventually the plate voltage is so low that most of the further increase in cathode current goes to the screen. At this point the first grid voltage rises at the discharge rate of C and carries the cathode with it until G_3 again cuts off the current to the plate. The plate immediately rises to $B+$ carrying the first grid with it,

and after a short transient period the tube returns to its original state.

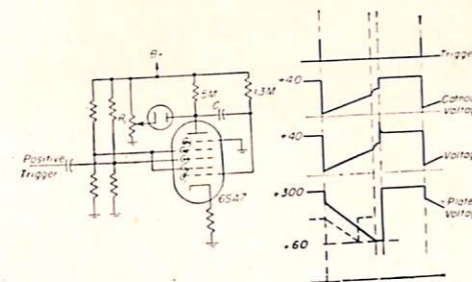

FIGURE 69—Phantastron.

Placing the diode in the circuit prevents the plate from reaching the $B+$ voltage. Its action is to move the plate-voltage curve to a lower value, as shown by the dotted line in figure 69(b). Since the plate-voltage curve is very linear on the down slope, the length of time required for recovery is decreased in proportion to the voltage applied to the diode. Thus R_1 may be used to control the time delay between the trigger and the rapid plate rise. This plate rise is used as the output from which a delayed trigger is developed.

(4) *Phase-shift delay:* Where very accurate control of the time delay is desired, the method illustrated in figure 70 may be used. A sine-wave oscillator with stable frequency characteristics having a frequency considerably greater than the pulse-repetition rate is used as an accurate timing device. This oscillator may be used to generate the radar-pulse frequency by some counting-down device, or may be turned on in synchronism with the transmitter by methods to be described later.

The output of this oscillator is passed through a phase shifter in which the phase change may be varied con-

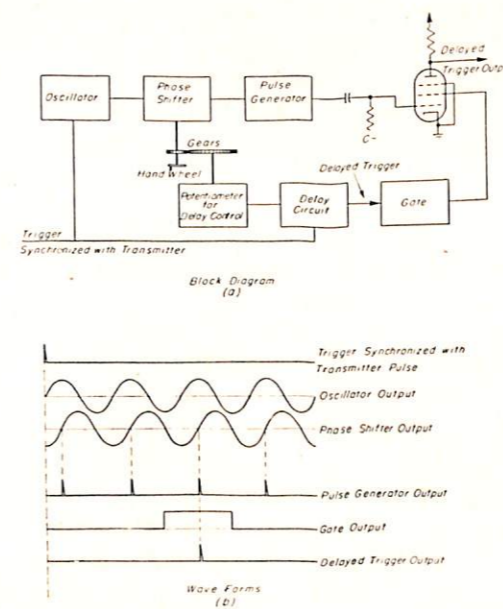

FIGURE 70—Accurate range delay circuit.

tinuously and accurately by turning a hand crank. The sine-wave output from the phase shifter is then formed into a series of "pips" by one of the methods described in Section V. As the hand crank is turned, any given pulse will appear to move along the time base and can be moved to any chosen point. If we watch a particular pip, we may mark the phase shifter when this pip coincides with the transmitted pulse and then, by observing the number of turns on the hand crank, determine the number of oscillator cycles required to move this pip to a given point. From this observation and the oscillator frequency the range may be computed. Considerable effort will be saved if a calibrated dial is geared to the hand wheel, and still further simplification will result if the oscillator frequency is chosen to make one cycle correspond to, for example, 1000 yards when the range is to be read in yards.

We must now find some method of eliminating all but the desired pulse if we wish to use it as a delayed trigger. This may be done by using a cathode-coupled multivibrator or phantastron to trigger a second multivibrator whose output acts as a gate to select the desired pip, as indicated in figure 70. The potentiometer which controls the delay is geared to the phase shifter so that the gate moves with the pip. Because there is considerable space between pips, the gate need not be moved with a high degree of accuracy; however, it must track accurately enough to let through only the desired pip.

(C.) *Range marks:* Although range to the target can be measured by a scale placed on the face of the tube, it is preferable to use electronic methods which are independent of the linearity and centering of the trace. One of the most commonly used methods, which is particularly suitable for timing the very short intervals involved, is to develop range-marking "pips" from the sine-wave output of an oscillator. The oscillator frequency is usually chosen to correspond to the desired spacing between marker pips. For example, to obtain markers one mile apart the frequency should be $1/T = 186000/2 = 93$ kilocycles, where T is the time for the pulse to travel to a target one mile distant and return. However, by the use of counting-down circuits this same oscillator can be made to give, for example, 5-, 10-, or 100-mile markers.

Figure 71(a) shows the basic method for obtaining electronic range marks. In systems in which an oscillator is used to control the pulse-repetition frequency, a continuously running oscillator may be used to generate the range marks, the pulse-repetition frequency being obtained by counting down. In systems in which the repetition frequency is determined by some other method, such as a rotary spark gap, the oscillator cannot be run continuously because then it will not be synchronized with the transmitter. For such systems the oscilla-

tor must be started from a completely stopped condition and synchronized with the transmitter each time a pulse is sent out. The oscillator, if still running when the transmitter operates, may be imperfectly synchronized. Where a tuned circuit is used to control the frequency the oscillations may be stopped in two or three cycles by short-circuiting the resonant circuit with a tube, as shown in figure 71(b). The oscillations will always start in the same phase when this tube is turned off by a multivibrator triggered by the transmitter. On the other hand, if a crystal oscillator is used, the crystal will vibrate for a considerable time after being short-circuited. Its oscillations, however, can be stopped rapidly by applying an out-of-phase voltage, as indicated in figure 71(c). Here, again, the impulse caused by turning off the switching tube will start the crystal in a definite phase. A crystal operated in this manner is not as stable as a steadily running crystal. Therefore, a good temperature-compensated coil-and-capacitor combination is almost as good as a crystal, since it is about as constant in frequency.

Figure 71(e) shows the sequence of wave forms for a range-mark circuit which is turned on by the transmitter, as indicated in figure 71(b). The range marks shown on the PPI photograph in figure 65 were generated by a circuit of this type. The oscillator frequency was set to give 10-mile pip intervals. The 50-mile marks were brightened by counting down by a factor of 5 to 1 and then superposing the 50-mile marks thus obtained on the original 10-mile marks.

(1) *Blocking oscillator:* A blocking oscillator such as that shown in figure 71(d) is used to convert the sine wave into these sharp range marks, and also as the

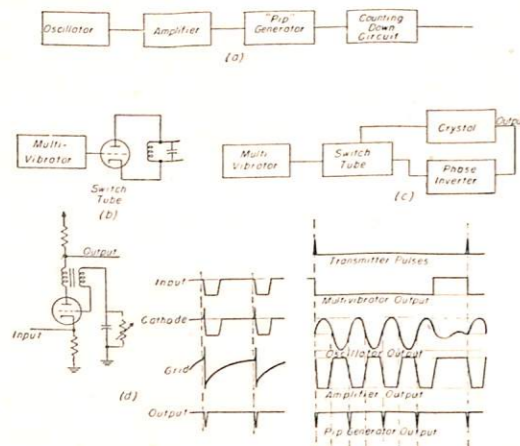

FIGURE 71—Range-mark circuit.

counting-down circuit to obtain the 50-mile marks. The tube is biased off by a charge on the grid capacitor, but the negative voltage of the input wave starts the tube conducting. The plate current drives the grid positive through the coupling transformer, thereby causing the grid to draw current and charging the capacitor. As

soon as the plate current reaches a steady value the voltage applied to the grid through the transformer falls to zero, because a transformer develops a voltage in its secondary only when the current in the primary winding is changing. This condition allows the grid to be carried negative by the charge on the capacitor. The plate, therefore, returns to B+, since the current is cut off, and remains there until the tube again becomes conducting, either because of the input or because the charge leaks off the capacitor through the resistor. If the resistor is so large that the grid is still too negative to permit the next negative input swing to turn the tube on, the blocking oscillator will not operate and will therefore count down.

PRECISE RANGING

Where very accurate range measurements are to be made, estimating the distance between range marks is inadequate. It then becomes necessary to bring a marker into coincidence with the signal. If the phase shifting device in the circuit sketched in figure 70 is accurately calibrated, the output pulse can be used as an electronic marker which may be moved to coincide with the signal, the range then being indicated on dials.

(a) *J-scan:* The J-scan offers another simple method of making very accurate range measurements. The tube used for the J-scan has two pairs of deflecting plates mounted at right angles, as in an ordinary cathode-ray tube. The sine wave from an oscillator is fed directly (or through a linear amplifier) to one pair of plates, and the same oscillator output, after passing through a 90-degree phase shifter, is fed to the other pair of plates. The resultant voltage from these two sine waves causes the beam spot to travel in a circle on the face of the tube. One complete circle is described for each cycle of range sweep. The radius of the circle is determined by the amplitude of the sine waves. The path will be an ellipse if the two waves are not equal in amplitude or if the phase shift is not exactly 90 degrees. In order to make the signal show as a deflection from this circle, the signal voltage must be applied radially between an electrode sealed in the center of the tube face and a conducting coating on the side wall of the tube. When the J-scan oscillator frequency is equal to the pulse-repetition frequency, the same signals on successive pulses will appear at the same points on the tube, and the range can be measured by a dial placed around the tube carrying a radial marker which is placed over the signal. If the oscillator frequency is some multiple of the pulse-repetition frequency the signals on successive pulses will still land at the same points on the tube, but there will be confusion as to the particular revolution of the sweep on which a given signal appeared. For example, if the pulse-repetition frequency is 9.3 kilocycles and the J-scan oscillator fre-

quency is 93 kilocycles, there will be ten superposed sweeps, each expanded by a scale factor of 10 over a J-scan operating at 9.3 kilocycles. In order to know whether the signal appeared at 5.6 miles rather than at, say, 1.6 or 7.6 miles, it is necessary to blank all but one revolution on the tube. A blanking gate operated by any of the delay circuits described earlier in this section may be employed; it need not be positioned with a high degree of accuracy because it is used merely to indicate which mile is involved. The accurate range is measured by positioning a pointer over the signal as previously described; but, since this scale has been expanded by a factor of 10 in this example, the range measurements can be made with greater accuracy. For convenience of operation, the blanking gate is geared to the range dial.

The ability to present range on a dial means an ability to turn a mechanical shaft in accurate correspondence with the range. This ability is extremely important because it provides a means of feeding range data to gun directors, bomb-release-point computers, automatic-plotting tables, and other computing or plotting devices.

B-SCAN

Indicators such as the B-scan, RHI, and PPI require, in addition to a range sweep, a voltage which is a function of the antenna position. Let us begin the discussion with the B-scan since it is the simplest case, and one which requires a voltage proportional to the azimuth angle of the antenna.

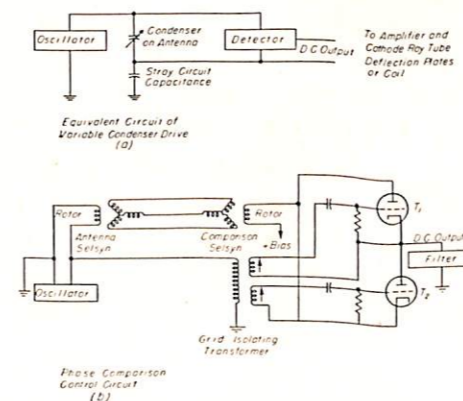

FIGURE 72—B-scan azimuth sweep-control circuits.

The simplest method of obtaining this voltage is to attach a potentiometer to the shaft in the antenna pedestal. For presentation of the full 360 degrees on the B-scan the potentiometer will have to be wound to cover a complete circle, except for a small space to separate the two ends of the winding. All potentiometers are apt to give trouble because of dirt, which causes poor contact between the sliding arm and the windings. A potentiometer gives an excellent solution to the problem in applications where this dirt can be kept out.

The second method is to attach a linear variable capacitor to the azimuth shaft. A high-frequency alternating current which is subsequently rectified is used, and the variable capacitor together with the cable and circuit capacitance is used as a voltage divider. The equivalent circuit is shown in figure 72(a). Because of the geometry of a variable capacitor, a B-scan built on this principle can cover only 180 degrees; and unless the stator plates can be rotated by the operator, the 180-degree coverage cannot readily be shifted to a different sector.

A third method is based on the use of a phase-shifting device which is rotated by the antenna mount. In figure 72(b) a pair of selsyn transformers is used. When the two rotor coils are in the same position with respect to the stators, the phase shift is zero. The phase shift changes from this point in proportion to the angle of rotation of the rotor. A brief consideration of this circuit shows that tube T_1 conducts only when the grid voltage and plate voltage are positive, and that T_2 conducts only when the grid voltage is positive and the cathode voltage negative. Thus, both tubes act as half-wave rectifiers with T_1 rectifying only the in-phase components, thereby driving the output positive from a voltage point which is determined by the bias applied to the output selsyn rotors. When the selsyn output is out of phase with the oscillator, T_2 drives the direct-current output negative with respect to the equilibrium point. Since the comparator output is essentially sinusoidal with respect to the angle of rotation of the antenna, a B-scan operated in this manner will be reasonably linear only over a 90-degree sector. Therefore, a single B-scan of this type is not adequate for 360-degree search. One advantage of this circuit lies in the fact that the comparison selsyn may be placed within easy reach of the operator, so that he can select the 90-degree sector to be viewed by adjusting the selsyn rotor position.

Both the capacitor-driven 180-degree B-scan and the selsyn-driven 90-degree unit require blanking of the return azimuth sweep.

C-SCAN

A C-scan can obviously be built by using these types of sweep controls, one unit being operated by the azimuth antenna position and the second by the elevation.

RANGE-HEIGHT INDICATOR (RHI)

In an ideal RHI, the constant height lines should be straight and perpendicular to the constant-range lines. The height H of the target is given by

$$H = R \sin \theta$$

where R is the slant range and θ is the elevation angle of the antenna when pointed directly at the target. This

equation may be solved electrically by feeding the range saw-tooth sweep through a device whose output is equal to the sine of the elevation angle. The output sweep from the sine computer is then applied to the cathode-ray tube to give a vertical deflection, and the range sweep provides a horizontal deflection. The resultant path of the spot on the cathode-ray tube will be along a diagonal.

A potentiometer wound so that the resistance varies as the sine of the angle of the contact arm may be used, but a simpler method is to wind a uniform resistance on a flat card. If the voltage is picked off by an arm pivoted as shown in figure 73(a), the output voltage will vary as the sine of the angle θ . The only electrical contact between this arm and the card is at the sliding contact. Figure 73(a) also shows the basic RHI circuit. The height scale may be expanded by amplification of the sine-potentiometer output.

A capacitor voltage divider may also be used as height computer if the plates are properly shaped.

Figure 73(b) shows another method of obtaining a voltage proportional to the sine of the angle. The "resolver" in principle consists of two sets of coils. The stator establishes a uniform field in which a rotor coil is placed. The coupling between the stator and rotor will vary with the sine of the angle as indicated. This resolver may be substituted for the sine potentiometer in the circuit in figure 73(a).

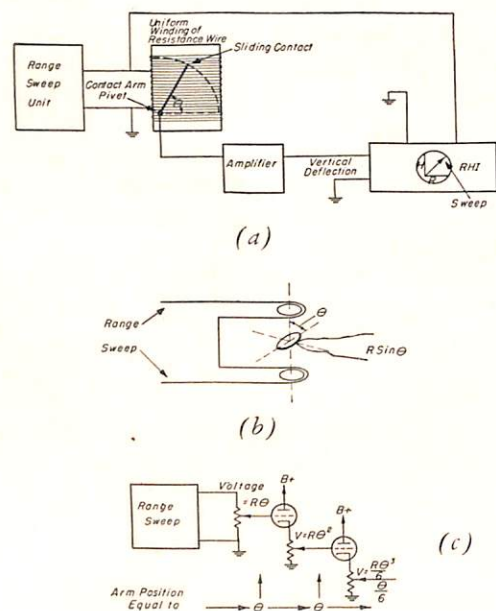

FIGURE 73—Range-height-indicator sweep circuits.

Another method which gives an approximate solution is to make use of the equation

$$\sin \theta = \theta - \frac{\theta^3}{3!} + \frac{\theta^5}{5!} - \frac{\theta^7}{7!} + \dots$$

The series, which must have an infinite number of terms to be exact, is cut off at the term which is smaller than the permissible error. Each term is then separately produced by suitably designed electrical and mechanical systems, and the voltages are added. For example, the term $\theta^3/3! = \theta^3/6$ may be produced by three linear potentiometers, as shown in figure 73(c). The cathode followers are used to prevent loading of one potentiometer by the next, but play no other role in the circuit since their voltage-amplification factor is essentially unity.

PPI

If two arms of equal length at right angles to each other are used to make contact on the resistance card shown in figure 73(a), one contact point will give a voltage proportional to the sine of the angle and the other a voltage proportional to the cosine. Obviously, the pivot must be moved to the center of the card if 360-degree rotation is required. The cathode-ray spot will sweep radially from a point on the tube face, if the horizontal sweep connection in figure 73(a) is removed from the range-sweep unit and connected to the second arm through an amplifier identical with that in the vertical sweep circuit. The position of this point will be determined by the direct-current and voltage conditions in the circuit when no range-sweep saw tooth is present. This point will be at zero range, thereby corresponding to the map position of the antenna. The angular direction of the radial sweep will follow the angular direction of the antenna and the range mark will trace out a circle on the tube face as the antenna rotates. These statements may be verified by plotting the spot position for constant angle with the range varying, and for constant range with the angle varying, remembering that the sine and cosine voltages are applied at right angles to each other.

As in the case of the RHI, the potentiometer may be replaced by a resolver having two rotor coils placed at right angles. One coil will give a sine function and the other a cosine function.

These PPI sweep drives can be used with either electrostatically deflected or magnetically deflected tubes.

A very simple PPI sweep mechanism can be made with a magnetic deflection coil. If the coil is placed to give a magnetic field at right angles to the electron beam, the cathode-ray spot will move at right angles to both the magnetic field and the electron beam when the current is changed through the coil. If the coil is rotated about the electron beam as an axis, a range sweep fed into the coil will cause the spot to move radially. The angular direction of the sweep will correspond to the azimuth angle of the antenna if the coil is rotated in one-to-one correspondence with the antenna.

In order that a true map picture may be presented, the zero range or starting point of all range sweeps, regardless of direction, must be at the same point on the tube face. This condition requires the current in the coil to be zero at the beginning of each range sweep. The position of the zero range point may be altered by adjusting the angular position of and current through another deflection coil which remains stationary as the antenna rotates. Figure 74(b) shows an "off-center PPI" in which the zero range point has been moved to one edge of the tube. Actually, the center may be moved completely off the tube face.

SERVO CONTROLS

The coil in the "rotating-coil PPI" may be driven directly from the antenna by a flexible shaft or through

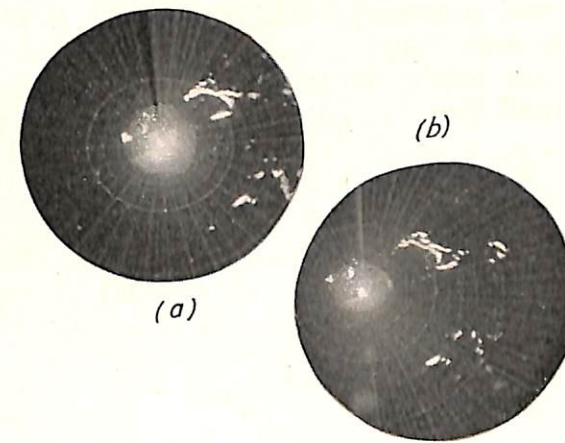

FIGURE 74—Off-center plan-position indicator.

gears, but this method may be extremely inconvenient if the antenna is several hundred feet from the PPI.

If the torque required to turn the PPI coil is very small, the coil may be driven by a pair of selsyns connected as shown in figure 75. When the two rotors are lined up electrically, the induced voltages in the stators are canceled and there is no torque on the shafts. The voltages will no longer be canceled if one rotor is turned from the position. This unbalanced voltage will produce torques on the two rotor shafts in the proper directions to make them realign in the no-torque po-

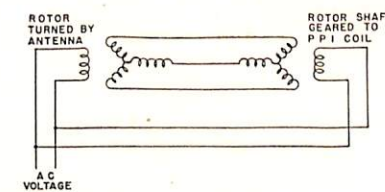

FIGURE 75—Selsyn drive.

sition. The torque increases as the displacement between the rotors increases. Thus, if one rotor is turned and the other is free to rotate, the latter will follow the former, attempting to remain in the no-torque position. Frictional drag in the following selsyn will cause some lag in angle; hence its position will be uncertain by a few degrees. If the antenna selsyn is geared up by a ratio of 10 to 1 and the PPI is geared down 10 to 1 from its selsyn, the PPI coil will still make one revolution for each revolution of the antenna; but the selsyns will make ten revolutions. A lag of 5 degrees between the selsyns will then cause only 0.5-degree lag of the PPI coil from the antenna because of the gear reduction. Introduction of this gear system also results in ten stable positions (separated by 36-degree intervals) of the PPI coil with respect to the antenna, because the follower selsyn locks in 1-to-1 correspondence with the antenna selsyn and not with the antenna.

In applications where large torques are required it is not feasible to use a selsyn drive, but the phase difference between two selsyns may be converted to a voltage which may be used to drive a motor. If the motor turns both the follower selsyn and the system which is being driven, the rotation will continue until the selsyns are again lined up. The motor must obviously be capable of reversing when the follower selsyn gets ahead of the transmitter selsyn in angle. Since there are a great many types of "servo-control" systems, a complete survey would require a highly technical discussion of the reasons for the different factors involved in selecting a particular type for a given job. Therefore, only two simple systems will be discussed to illustrate the general problem.

Figure 76 shows a circuit used to control a two-phase alternating-current motor. The amplified selsyn output is fed to one coil of the two-phase motor, while the alternating current from the power line is connected to the other coil. When these two waves are in phase,

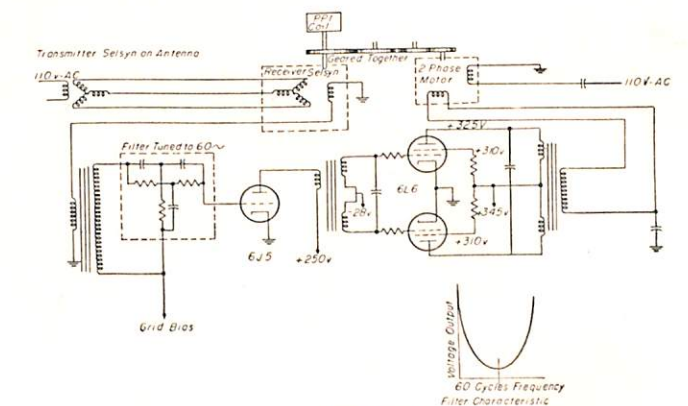

FIGURE 76—Alternating-current servo system.

no torque is developed. Displacement of one of the selsyns creates a phase shift which results in a torque on the motor. In order to have a stable system, this torque obviously must act in the proper direction to decrease the phase shift. In order to reduce the time lag of the motor system in following the transmitter selsyn, a signal proportional to the rate of change of the receiver-selsyn output is also fed through the amplifier. Thus, when the transmitter selsyn is suddenly turned, the torque on the motor is greater than that caused by the selsyn output alone by an amount proportional to the rate at which the two selsyns become out of step. The selection of the proper type of rate signal is greatly dependent on the mechanical system to be controlled and is one of the most important and most involved items in servo design.

The "parallel-T" filter in figure 76 has the band-pass characteristic shown. Therefore, the voltage applied to the 6J5 grid increases as the frequency departs from 60 cycles. A change in error signal from the receiver selsyn may be considered as made up of a pure 60-cycle sine wave plus a modulating wave whose frequency is the rate of rotational displacement between the two selsyns. This modulation then results in output frequencies of 60 cycles plus and minus the rotation frequency. Since the grid swing is greater for these sum and difference frequencies than for the steady 60-cycle signal after passing through the filter, the power applied to the motor is increased by an amount dependent on the rate of change of the selsyn error signal. If the filter response curve is too broad, the servo does not follow quickly and accurately; while if it is too sharp, the servo oscillates about its stable equilibrium point.

A circuit of the type illustrated in figure 77 may be used to drive a split-field direct-current motor. The pulsating direct-current output of a phase comparison circuit, such as that shown in figure 72, is passed through

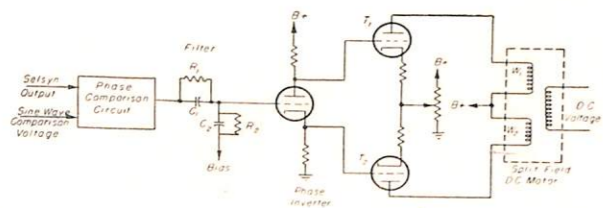

FIGURE 77—Direct-current servomotor drive.

a filter network and is applied to a phase inverter. When the direct-current voltage on the grid of the phase inverter rises above the equilibrium voltage, the phase inverter draws more currents. This action raises the voltage of the grid of T_2 and lowers that of T_1 , thereby

causing the current in the winding W_2 to increase and that in W_1 to decrease. If these currents are originally adjusted to produce canceling torques in the motor, this change in current balance causes the motor to run in one direction. On the other hand, if the phase-inverter grid swings below the equilibrium point, the current unbalance in the motor causes rotation in the opposite direction.

The filter R_2 and C_2 is adjusted to smooth the output of the phase comparison circuit, while R_1 and C_1 are adjusted to give a voltage which depends on the rate of change of the selsyn output. In other words, R_1 and C_1 perform the function of the "parallel-T" filter in the case previously discussed.

The servo-control mechanisms used in radar may vary from small units, such as are used for driving PPI coils, to units of many horsepower for turning antennas. As a rule, some power-control device other than a vacuum tube is used to supply the final power to the motor in large servo systems. Nevertheless, the basic principle is as sketched here.

ANGLE MARKS

Angle marks may be put on indicators by the simple expedient of a slotted disk, turned by the antenna. Light from a bulb actuates a photoelectric cell when the slots are in the correct position. The photocell output is then amplified and is used to change the intensity of the cathode-ray spot.

MAP PRESENTATION

When a "television picture" of a map is combined with the video from the radar, the picture of the map will appear on the indicator along with the signals. Since the radar picture is scanned rapidly in range at the pulse-repetition frequency and slowly in angle with the rotation of the antenna, the "television" picture of the map must be scanned in the same manner if it is to combine properly with the radar video. The spot on a PPI will scan a map in the proper manner if the map is of the correct scale and is placed on the tube face. Therefore, a PPI adjusted to give a bright spot may be used as a light source to scan a transparency placed on the tube face. No signals are applied to this PPI, of course. The light which passes through the clear space on the film is picked up by a photoelectric cell whose output is amplified and mixed with the radar signals for presentation on another PPI or on a B-scan. This device may be useful in directing aircraft to landing fields in bad weather since the position of the plane and field may then be clearly seen together on the radar tube.

(Concluded next month)

NAVSHIPS (NBS) 383A
NAVY DEPARTMENT
BUREAU OF SHIPS
WASHINGTON, D. C.
OFFICIAL BUSINESS

PENALTY FOR PRIVATE USE TO AVOID
PAYMENT OF POSTAGE, \$300

NAVY DEPARTMENT
BUREAU OF SHIPS
ELECTRONIC EQUIPMENT, CODE 980
WASHINGTON, D. C.

FAILURE REPORT—ELECTRONIC EQUIPMENT
NAVSHIPS (NBS) 383 (REV. 8-45)
FORMERLY NAVSHIPS (NBS) 383 AND NAVSHIPS (NBS) 304

SHIP NUMBER AND NAME OR STATION _____ DATE _____

CHECK ONE: RADIO RADAR SONAR OTHER _____

EQUIPMENT MODEL DESIGNATION _____

TYPE NUMBER AND NAME OF MAJOR UNIT INVOLVED _____ SERIAL NO. OF EQUIPMENT _____

TUBE TYPE INCLUDING PREFIX LETTERS _____ TUBE MANUFACTURER _____

THIS SIDE FOR TUBES

FAILURE OCCURRED IN: STORAGE OPERATION HANDLING OTHER (SPECIFY) _____

GUARANTEED HOURS (NOTE 7) _____ CONTRACT NO. (NOTE 7) _____

ACTUAL HOURS _____ DATE OF ACCEPTANCE (NOTE 7) _____

TYPE OF FAILURE (NOTE 8) _____ DATE OF FAILURE _____

TUBE CIRCUIT SYMBOL _____

NATURE OF FAILURE AND REMARKS (NOTE 9): _____

ITEM WHICH FAILED

NAME OF CONTRACTOR _____ SERIAL NO. OF UNIT _____

NAME OF PART _____

BRIEF DESCRIPTION AND CAUSE OF FAILURE INCLUDING APPROXIMATE LIFE: _____

THIS SIDE FOR COMPONENTS

CIRCUIT SYMBOL (R-134) _____

NAVY TYPE, STOCK OR MFR.'S NO. _____

CONTRACT NO. _____ DATE EQUIPMENT INSTALLED _____

NAME OF PERSON MAKING REPORT _____

NOTICE—Read notes on reverse side. Addl. local forms and envelopes may be obtained from nearest RMC.

(Do not delay submitting this form—Insert in envelope—Seal—Mail)
CONTINUE REMARKS ON REVERSE SIDE

32 CONFIDENTIAL

NEED THESE?
THEY ARE EASY TO GET.

Why do extra work mimeographing or typing extra copies. Such facsimiles are acceptable in an emergency, but little effort is required to obtain necessary supplies of these forms. Merely fill out a Stock Form and Publications Requisition (NAVGEN-47) and forward it to the nearest Publications and Printing Office.



DISCOVER SOMETHING?

ELECTRON is your magazine! Your contributions are a useful source of technical information. This information, through ELECTRON magazine, is then made available to all. Write up your contribution and send it directly to us, via your C. O., including sketches or photographs where appropriate.

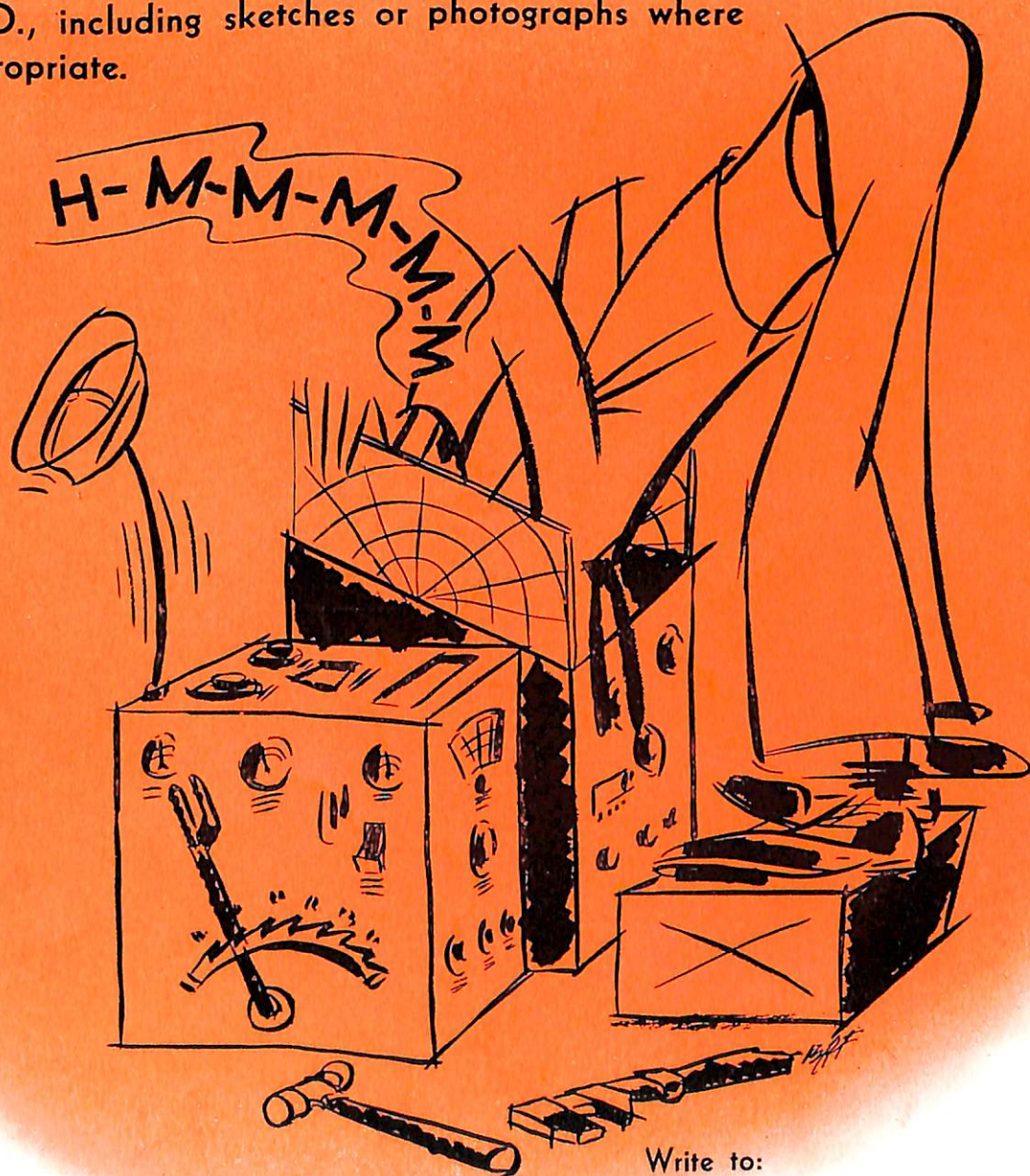

Write to:

EDITOR, BUSHIPS ELECTRON,
BUREAU OF SHIPS, CODE 993b,
NAVY DEPARTMENT,
WASHINGTON 25, D. C.