

Antenna Parameters of the U.S. Navy VLF Transmitting Station, NWC, Harold E. Holt at Exmouth, Australia

J. W. BROGDEN AND J. E. RAUDENBUSH

*Electromagnetic Propagation Branch
Communications Sciences Division*

AD743884

May 1972

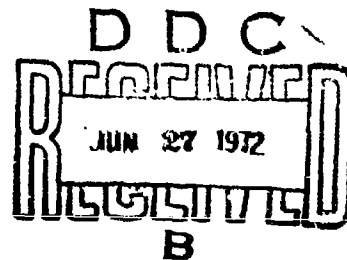

Reproduced by
NATIONAL TECHNICAL
INFORMATION SERVICE
U.S. Department of Commerce
Springfield, VA 22151

NAVAL RESEARCH LABORATORY
Washington, D.C.

R
25

DOCUMENT CONTROL DATA - R & D

(Security classification of title, body of abstract and indexing annotation must be entered when the overall report is classified)

1. ORIGINATING ACTIVITY (Corporate author) Naval Research Laboratory Washington, D.C. 20390		2a. REPORT SECURITY CLASSIFICATION UNCLASSIFIED	
3. REPORT TITLE ANTENNA PARAMETERS OF THE U. S. NAVY VLF TRANSMITTING STATION, NWC, HAROLD F. HOLT AT EXMOUTH, AUSTRALIA			
4. DESCRIPTIVE NOTES (Type of report and inclusive dates) This is a final report of one phase of this problem.			
5. AUTHOR(S) (First name, middle initial, last name) John W. Brogden John E. Raudenbush			
6. REPORT DATE May 1972		7a. TOTAL NO. OF PAGES 28	7b. NO. OF FIGS 3
8a. CONTRACT OR GRANT NO. NRL Problem 54R07-22		9a. ORIGINATOR'S REPORT NUMBER(S) NRI Memorandum Report 2440	
b. PROJECT NO. NAVELECSYSCOM Project X-1508		9b. OTHER REPORT NO(S) (Any other number that may be assigned to this report)	
c. Task EXD-1			
10. DISTRIBUTION STATEMENT Approved for public release; distribution unlimited.			
11. SUPPLEMENTARY NOTES		12. SPONSORING MILITARY ACTIVITY Department of the Navy Naval Electronic Systems Command Washington, D.C. 20360	
13. ABSTRACT <p>An investigation was conducted during October and November 1971 to determine the parameters of the antenna system at the U. S. Navy VLF transmitting station (call letters NWC) at the Naval Communications Station, Harold E. Holt, Exmouth, Australia. The results showed that there has been no noticeable deterioration of the antenna system since the "Proof of Performance" tests were made in 1967.</p>			

I

UNCLASSIFIED
Security Classification

14 KEY WORDS	LINK A		LINK B		LINK C	
	ROLE	WT	ROLE	WT	ROLE	WT
Antenna parameters VLF transmitter						

Handwritten mark

CONTENTS

ABSTRACT	ii
PROBLEM STATUS	ii
AUTHORIZATION	ii
INTRODUCTION	1
FIELD STRENGTH MEASUREMENTS	1
DATA ANALYSIS	2
TABLE I	3
TABLE II	4
MEASUREMENT OF GROSS RESISTANCE	5
METHOD OF GROSS RESISTANCE MEASUREMENT	5
TABLE III	7
BANDWIDTH MEASUREMENTS	7
CONCLUSIONS	8
RECOMMENDATIONS	8
ACKNOWLEDGEMENTS	8
REFERENCES	9
APPENDIX I	10
APPENDIX II	12
APPENDIX III	13
TABLE F	14
FIGURES 1 THROUGH 8	15
Distribution List	23

III

ANTENNA PARAMETERS OF THE U. S. NAVY VLF TRANSMITTING
STATION, NWC, HAROLD E. HOLT AT EXMOUTH, AUSTRALIA

INTRODUCTION

Measurements were made on the antenna system of the U. S. Navy very-low-frequency (VLF) transmitting station at the Naval Communications Station Harold E. Holt at Exmouth, Australia (call letters NWC), to determine if any deterioration had occurred since the "Proof of Performance" evaluation made during January and February 1967, references (1) and (2). The NWC antenna basically consists of one down lead and six diamond shaped panels for top loading. Two basic measurements were made. The first was to determine field strength at known distances and antenna currents, and from this compute the radiated power, effective height, and radiation resistance. The second was to determine the gross resistance of the antenna system. By making a comparison of these results with previous measurements it is possible to determine how much deterioration, if any, had occurred since the "Proof of Performance" evaluation. A decrease of efficiency of the antenna system can be caused by several things. Two important factors are the deterioration of the grounding system and the build up of salt and pindan* on the insulators, however, periodic maintenance keeps the latter to a minimum. Band width measurements were also made at the basic 22.3 kHz operating frequency.

FIELD STRENGTH MEASUREMENTS

The same techniques were used in measuring the field strength as were used in the "Proof of Performance" evaluation (reference (1)). Eleven sites employed in the 1967 measurements were located and found to be useable. Some of the sites could not be found and some on the east coast were not useable because of the installation of power and telephone lines. It was possible however to make measurements in these cases away from the influence of power and telephone lines and without any significant change in distance to the transmitter. The sites are divided into two groups, west coast and east coast and are at distances varying from approximately 20 to 65 kilometers. A detailed description of the sites employed in making these recent measurements is found in Appendix I. Eleven different sites were used, three being on the east coast and the remainder on the west coast.

*Pindan - A fine sand-like material typical of North West Australia.

The field strengths were measured using a DECO Field Intensity meter, Model C400-A manufactured by DECO Electronics. These equipments employ a loop antenna and use a substitution method to obtain field strength readings. They were calibrated at the Laboratory by the "two loop method" and referenced to a precision thermal milliammeter before the investigation. The milliammeter was transported to NWC along with the field strength measuring equipments, and employed at each site to calibrate the field strength meter before each series of readings. This procedure resulted in an instrumental accuracy approaching 0.1 dB in absolute field strength. A detailed description of the method of calibration is given in Appendix II.

The loop was carefully nulled at each site and then rotated precisely 90 degrees to assure maximum signal input. The depth of the loop null was noted in each case and used to evaluate the suitability of each site, as local anomalies can often produce poor loop nulls and errors in field strength readings. In each case, with one exception, the null was greater than 40 dB. A null of 33 dB was obtained at site 14 on the west coast, however, this is a satisfactory value and there were no indications of any anomalies in the vicinity.

The antenna currents were read by station personnel on the hour and each 15 minutes thereafter so the readings of field strength were made at these times to assure maximum accuracy. During the 55th minute of every odd hour UT the station transmitted in the (A-O) mode at 15.5 kHz enabling some data to be obtained at this frequency.

DATA ANALYSIS

The field strength meter employs a shielded-loop antenna and measures the resultant of the induction field and the radiation fields. However, at the distances at which the measurements were made the contribution of the induction field was small* but nevertheless it was considered in the data analysis. At site 3 the nearest one used, 19.85 km from the station, the contribution of the induction field accounted for only 0.16 dB of the total field.

The data from each site were normalized and averaged separately since more readings were taken at some sites than at others. All data were first normalized to an antenna current of 1800 amperes and to a distance of 100 kilometers, before being averaged to calculate the radiated power, radiation resistance, and effective height. A plot of the field strength values normalized to a constant antenna current as a function of distance is given in figures 1 and 2. As can be seen the points show a good correlation to the inverse distance law. In some cases two points are plotted at the same distance, to indicate data taken on two different days. Each point is the average of data on a given day.

*The induction field and radiation field are equal at $d = \lambda/2\pi$.

Tables I and II show the average values of field strength at the measurement sites for frequencies of 22.3 kHz and 15.5 kHz respectively. The field strength values for each site have been normalized to an antenna current of 1800 amperes and a distance of 100 kilometers. The site averages were again averaged to give a normalized field strength of 97.92 millivolts per meter for a frequency of 22.3 kHz and 64.47 millivolts per meter for the 15.5 kHz transmission.

TABLE I
22.3 kHz
Measurements

<u>Site</u>	<u>Distance (km)</u>	<u>E_{Id} (mV/m)</u>
W03	19.85	94.77
W04	23.35	97.91
W05	24.60	98.75
W06	26.60	103.52
W08	35.00	98.73
W11	44.90	101.68
W14	57.50	103.04
W15	63.30	104.21
Average of Western Sites		101.73
E23	26.60	92.58
E24	35.05	92.73
E29	54.15	90.26
Average of Eastern Sites		91.79
Average of all sites		97.92

E_{Id} = Field Strength in millivolts per meter normalized to an antenna current of 1800 amperes and 100 kilometers.

TABLE II
15.5 kHz
Measurements

<u>Site</u>	<u>Distance (km)</u>	<u>E_{Id} (mV/m)</u>
W03	19.85	63.12
W04	23.35	65.03
W06	24.60	66.79
W11	44.90	67.17
W15	63.60	66.28
	Average of Western Sites	65.08
E23	26.60	59.29
E24	35.05	63.76
E29	54.15	64.32
	Average of Eastern Sites	62.46
	Average of all sites	64.47

As can be seen the normalized field strength values were consistently higher for the western as compared with the eastern sites, but not significantly, the difference being only 0.35 dB at 22.3 kHz and 0.45 dB for 15.5 kHz.

Using the results as given in Tables I and II the radiated power can be computed by:

$$P_r = \frac{E_{Id}^2}{9}$$

For 15.5 kHz	$P_r = 461.8 \text{ kW}$
23.3 kHz	$P_r = 1065 \text{ kW}$

Where P_r is the radiated power in kilowatts and E_{Id} the field strength normalized to an antenna current of 1800 amperes and a distance of 100 kilometers.

The radiation resistance R_r is obtained from

$$R_r = \frac{P_r}{I_a^2}$$

For a frequency of 15.5 kHz:

1967 results	$R_r = 0.142$ ohms
1971 results	$R_r^f = 0.143$ ohms

For a frequency of 22.3 kHz:

1967 results	$R_r = 0.323$ ohms
1971 results	$R_r^f = 0.329$ ohms

As can be seen there is little change from the previous measurements (references (1) and (2)).

The effective height is obtained from

$$h_e = \frac{7.96 \times 10^9 E_{Id}}{I_a f}$$

at 15.5 kHz $h_e = 184$ meters

at 22.3 kHz $h_e = 194$ meters

MEASUREMENT OF GROSS RESISTANCE

The gross resistance of the MWC antenna system was measured and the results compared with that obtained during the "Proof of Performance" Tests (reference (2)) which were conducted in 1967. These measurements were made to determine if any significant increase in the gross resistance has occurred. Any increase in resistance would be chiefly due to an increase in ground system power losses because of the corrosion of the wires in the ground plane. There will also be an increase in insulator loss due to build up of salt and pindan, however, this should be a minor effect as they are periodically cleaned. The effects of contaminated insulators are also less noticeable during periods of dry weather, such as existed on the day when these measurements were made.

The results showed that there were no significant changes in the gross resistance as shown in Figure 3 which is a plot of R_g vs frequency. The method of measurement and tabulated results are given in the following paragraphs.

METHOD OF GROSS RESISTANCE MEASUREMENT

The method of measurement was similar to that used during the proof of performance test (reference (2)). A simplified diagram of the instrumentation is shown in Figure 4.

The bridge circuit consists of two conductors threading a ferrite-cored toroidal pickup coil, with the conductors arranged so that the currents flowing in the conductors are in parallel opposition. From a common input source the two conductors branch apart with one conductor connected to the antenna system input, and the second conductor connected to decade precision resistors. The pickup coil is connected

to a detector. In operation, after tuning the antenna system to resonance, the decade resistors are adjusted until the detector indicates a null condition. This bridge balance condition indicates that the decade resistors are now equal in value to the antenna gross resistance. A detailed explanation of the instrumentation and its use is given in Appendix III.

All the measurements were made using the right helix and connected as shown in the simplified circuit diagram. (Figure 5).

Switch K4001 was opened to remove the bandwidth resistor W4701 from the circuit and the section of line containing the reflectometer was taken out to isolate the helix and antenna from the transmitter and the matching circuits.

Physically the measuring equipment was connected as shown in Figure 6. The instruments were set on a concrete pier which supported a 10-inch ground bus coming from the coupling variometer. The ground bus was unbolted from the Helix-House wall and isolated from it as shown in Figure 6. This connection is approximately 10 feet above the floor of the Helix-House. The bridge ground was made at a point where the bracket that holds a sampling loop is bolted to the wall. This resulted in a ground lead which was about 5 feet long. The other side of the bridge (antenna side) was connected under two of the flange bolts that attach the coupling variometer lead to the ground bus. This lead was about 2 feet long. These connections were made with solid copper strap $1\frac{1}{2}$ " x 0.020". Particular care was used to assure that all the instrumentation resistances were as low as possible. A Kelvin bridge was used to determine the resistance of the measuring system. The resistance between the high side strap and the ground strap with the decade resistors set to zero was found to be 0.01 ohms. The contact resistances between the ground strap and Helix wall; and the high side strap and the Helix column were found to be less than 0.001 ohms.

A measurement was made by tuning the antenna to a nominal frequency and then adjusting the bridge oscillator until the voltmeter across the current sampler indicated resonance. The decade resistors were then adjusted to obtain a null as indicated by the 040-A field strength meter. Fortunately the atmospheric noise was low on the day the measurements were made and therefore it was possible to obtain good null indications. The results are given in Table III and plotted in Figure 3. The results of the measurements made in 1967 by DEK are also shown in this Figure, and as can be seen there are no significant changes in the gross resistance since the original measurements.

TABLE III
Gross Resistance NWC Antenna and Right Helix

Frequency kHz	R_g Ohms	Range
14.174	0.175	1
15.460	0.20	1
17.805	0.25	1
19.691	0.29	2
22.311	0.365	2
24.318	0.44	3
25.016	0.49	2
25.198	0.50	3
25.355	0.48	3
25.580	0.50	3
26.561	0.525	3
26.910	0.545	3

Correction Factor +0.01 ohm

The decade resistors were checked against two Leeds-Northrop Kelvin Bridges and it was found that a correction factor of 0.01 ohm was required, and has been applied to the values of R_g in Table III.

The range in Table III refers to the auxiliary inductors needed to tune the antenna system to resonance at the lower frequencies. Range 1 is with inductors L4001 and L4002 connected in series, range 2 is with L4003 only, and range 3 is with none of the auxiliary inductors connected.

BANDWIDTH MEASUREMENTS

A bandwidth measurement was made at a nominal frequency of 22.3 kHz and the antenna system tuned as it normally is for FSK operation. Two methods were used to obtain the antenna system bandwidth. The first was to take the field strength equipment about three miles from the antenna and measure the field strength vs frequency. This was done at low power and a constant drive to the antenna system. The results are shown in Figure 7. A second bandwidth curve (Figure 8) was obtained from the antenna current obtained at each frequency. The variation between the two curves is principally due to the inability to read the antenna current meter accurately at low levels. The transmitter was not available long enough to make a bandwidth determination at more than one operating frequency.

CONCLUSIONS

Measurements of the radiated power and antenna parameters show that no noticeable deterioration of the antenna system has taken place since the 1967 "Proof of Performance" evaluation.

RECOMMENDATIONS

(a) It is recommended that annual checks of radiated power be made to detect any loss of efficiency of the antenna system that may have taken place. Only one site is necessary for this and it is recommended that it be site number 4.

(b) It is also recommended that an investigation be made to determine the feasibility of developing a more accurate and precise antenna current measuring system. Although the present method is satisfactory for operational use, an increased accuracy is desirable for the measurement of antenna parameters.

ACKNOWLEDGEMENTS

Acknowledgement is hereby made to Warrent Officer J. E. Miller and all of the communication station personnel of Harold E. Holt for their cooperation and assistance in conducting these measurements, as well as Mr. W. E. Garner of this laboratory who collaborated in making the measurements.

REFERENCES

(1) Garner, W. E.; Raudenbush, J. E.; and Brookes, C. B., Jr., "Radiation Parameters of the VLF Transmitting Station NWC, North West Cape, Australia", NRL Memorandum Report 1783, 21 June 1967.

(2) Joint Report by Holmes and Narver, Inc., Continental Electronics Manufacturing Company and DECO Communications Department, Westinghouse Electric Corporation, "U. S. Naval Communication North West Cape, Australia" Appendix II, VLF Antenna System Characteristics prepared for Naval Facilities Engineering Command, Contract NBy 53166, 29 September 1967.

(3) Jean, A. G.; Taggart, H. E.; and Wait, J. R., "Calibration of Loop Antennas at VLF", Journal of Research of the National Bureau of Standards C. Engineering and Instrumentation, Vol. 65, No. 3, July-September 1961.

APPENDIX I

FIELD STRENGTH MEASUREMENT SITES

In conducting the 1967 field strength measurements in connection with the "Proof of Performance" evaluation, a total of 31 sites were employed. For these recent measurements, a total of 11 representative sites were employed, eight of the sites being on the west half and three on the east half of the peninsula.

SITES ON THE WEST HALF OF CAPE

An improved road has been constructed along the west coast of the Cape subsequent to the 1967 measurements, replacing the old "dirt track", which was the only north-south road on the west side of the peninsula in 1967. All distances pertaining to the location of the west coast sites are measured along this "new" road.

SITE NUMBER 3

This location is 5.8 miles south from Five-Mile Gate or 2.5 miles south from the fork of the new road, and the old road leading to the Yardie Creek Homestead. This site is also 2.4 miles north of Site Number 4 and 3.3 miles north of the Tantabiddi Well and Fence. The loop is placed 15 feet east of the road.

SITE NUMBER 4

This site is 8.2 miles south from Five-Mile Gate and 2.4 miles south of Site Number 3. The site is also 0.9 miles north of Tantabiddi Well and Fence. The site is 250 feet west of the road. This is the site recommended to be employed by personnel at the transmitting station when making any future comparative measurements to check the antenna radiation performance.

SITE NUMBER 5

This site is 9.2 miles south from the Five-Mile Gate. It is also 1.4 miles north of Site Number 6 and 6.0 miles north from the fence at Milyering Well. The detailed location of the site is 500 feet from the Tantabiddi Well in a direction away from the transmitting antenna.

SITE NUMBER 6

This site is 1.5 miles south of the Tantabiddi Well and Fence and 4.6 miles north of the fence at Milyering Well. The site is 250 feet west of the road.

SITE NUMBER 8

This site is 1.45 miles south of the fence at Milyering Well and 6.0 miles south of Site Number 6. The site is also 4.3 miles north of the fence at Tulki Well. The site is 250 feet west of the road.

SITE NUMBER 11

This site is 2.5 miles south of the fence at Tulki Well and 4.9 miles north of the fence at Pilgramunna Well. The site is 150 feet west of the road.

SITE NUMBER 14

This site is 8.8 miles south of Site Number 11 and 3.9 miles south of the fence at Pilgramunna Well. It is also 3.9 miles north from Site Number 15. The site is 40 feet west of the road.

SITE NUMBER 15

This site is 7.8 miles south of the fence at Pilgramunna Well and 3.95 miles south of Site Number 14. It is also 1.0 mile north of the fence at Yardie Well. The site is 200 feet east of the road.

SITES ON THE EAST HALF OF THE CAPE

SITE NUMBER 23

This site is along the Shothole Canyon Road, 1.3 miles west of the turnoff from the main north-south highway. The Shothole Canyon Road is 3.6 miles south of Munbowra Creek. This site has been relocated 0.3 of a mile closer to the main highway than the original site, to avoid a recently erected power line. No marker.

SITE NUMBER 24

This site is on the east side of the main north-south highway, opposite the Charles Knife Road turnoff. This site was moved from the west side of the highway to avoid a buried cable. The marker is missing.

SITE NUMBER 29

This site is 4.1 miles south of the road leading to the Learmonth airport from the main north-south highway. The marker is 100 feet west of the highway, but the loop should now be placed on the east side of the road to avoid a buried cable.

NOTE: Except as noted above, all measurement sites are indicated by a marker as shown in reference (1). The name plate on these fence post markers contains the following information:

Communication Sec.
Radio Div. II
Naval Research Laboratory

NRL No. 5419

Serial No. [Site Number]

APPENDIX II

CALIBRATION OF FIELD STRENGTH METERS

The "Two Loop" method was used to calibrate the field intensity meters at the laboratory (reference (3)). This is a precise procedure whereby the field strength equipment can be calibrated to an absolute accuracy of 0.1 dB or better.

The loop of the field strength meter is placed co-axially with a test loop at a known distance "d" and a known current is passed through the test loop by means of a standard signal generator. The equivalent electric field at the receiving loop is given by:

$$E = \frac{60 \pi r_1^2 I}{(d^2 + r_1^2 + r_2^2)^{3/2}} \left[\frac{1 + (r_1 r_2)^2}{d^2} \right]$$

where

I = Current in amperes in test loop

r_1 = Test loop radius in meters

r_2 = Receiving loop radius in meters

d = loop spacing in meters

E = Equivalent electric field strength in volts per meter

This expression is valid for determining the field strength at the receiving loop if r_1 , r_2 , and d are very much smaller than the wave length, and if r_1 and r_2 are comparable in size. It is also necessary that the equipment be set up several times the loop spacing, d, from surrounding objects. The resulting measurement should not be in error greater than 0.1 dB.

The field strength meter is connected to the receiving loop and a reading made in the usual manner, the output of the "substitute generator" having been referenced to a precision thermal milliammeter. The difference between the field strength meter and the computed field, if any, is compensated for by using the difference as a correction factor. Then if each time the field strength meter is used in the field it is calibrated with the thermal milliammeter and the appropriate correction factor applied, an instrumental accuracy of 0.1 dB can be approached. The particular instrument (serial 007) which was used for the NWC measurements required no correction factor.

APPENDIX III

INSTRUMENTATION FOR MEASURING GROSS RESISTANCE

The block diagram for the gross resistance measurement instrumentation is shown in Figure 4, and the principal instruments are listed in Table IV.

The balance circuit consists of a ferrite toroid threaded by two 3/8" copper conductors and connected so that the current in each one will pass through it in opposite directions. One end of one of the conductors is connected to the antenna circuit and one end of the other conductor to standard decade resistors which are connected to ground. When the resistance of the decade resistors equals the gross resistance of the antenna at resonance, the currents will be equal and opposite and a null will be indicated. One hundred turns of wire were wound around the toroid and connected to C-400A field intensity meter to detect this null. It was found that there was too much gain when used with the C-400A meter and the secondary turns on the toroid had to be loaded with a 10 ohm resistor. Future designs will incorporate an attenuator so the bridge can be used either with a wave analyzer, vacuum tube voltmeter, or a sensitive field strength meter as a null detector.

The other two ends of the primary conductors are fastened together and connected to the signal source. The purpose of the current sampler is to determine the current through the system. The current through the standard resistance used had to be limited to about one ampere. The current sampler is also used to indicate the resonant frequency. The antenna was first set to a nominal frequency and then the oscillator adjusted until resonance was indicated by the current sampler. The gain of the McIntosh amplifier was then increased until the current through the standard resistance equaled the maximum permitted. It is desirable to have the current as high as possible to overcome the noise in the system caused by atmospherics, other signals, etc. The McIntosh amplifier was chosen for its ability to supply relatively large amounts of power at low distortion.

After a balance was obtained the current to the bridge was increased as it was divided between the standard resistance and the antenna system. In this manner the sensitivity was increased without exceeding the current limitations of the standard resistor.

TABLE IV

<u>Item</u>	<u>Manufacturer</u>	<u>Model</u>	<u>Serial</u>
Oscillator	General Radio	Type 1312 Decode Oscillator	243
Counter	Eldorado	1607 CY	131
Amplifier	McIntosh	MC75-75 Watt	276 BO
Null Detector	DECO	C400-A	007
Decode Resistor	Leeds and Northrup	4764	713518
Current Bridge	NRL	--	--

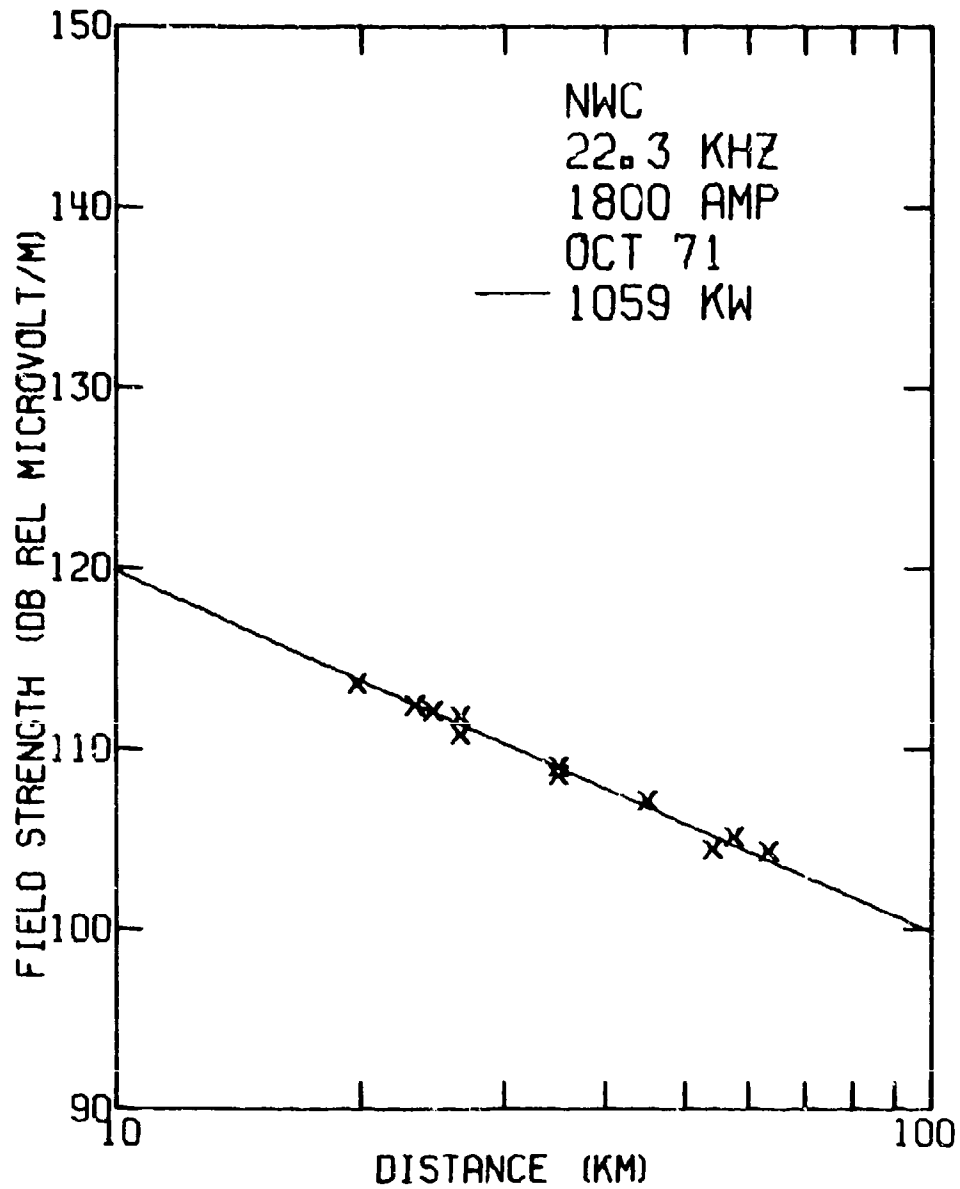

Fig. 1 - Field strength normalized to a constant antenna current, as a function of distance from the transmitting antenna. Frequency is 22.3 kHz.

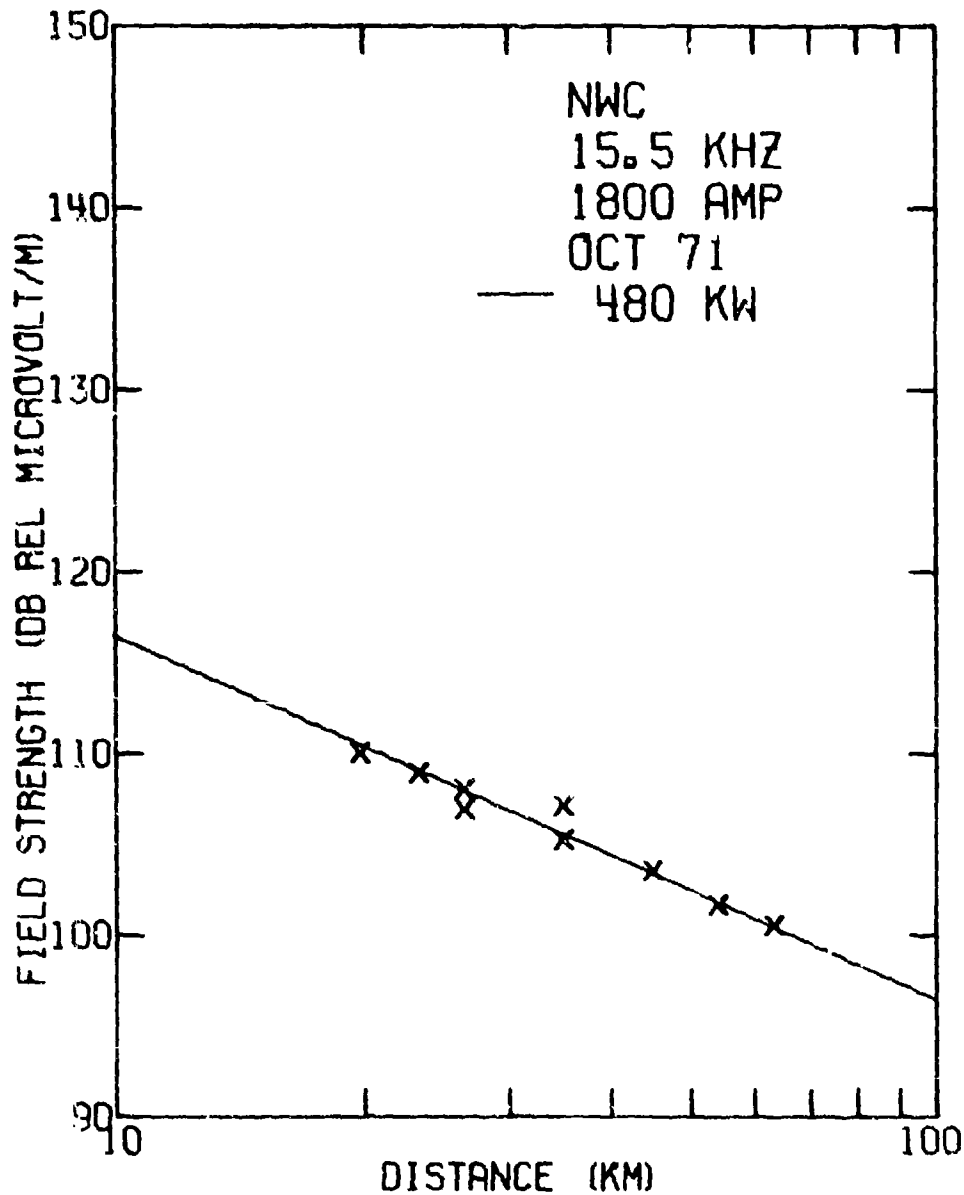

Fig. 2 - Field strength normalized to a constant antenna current, as a function of distance from the transmitting antenna. Frequency is 15.5 kHz.

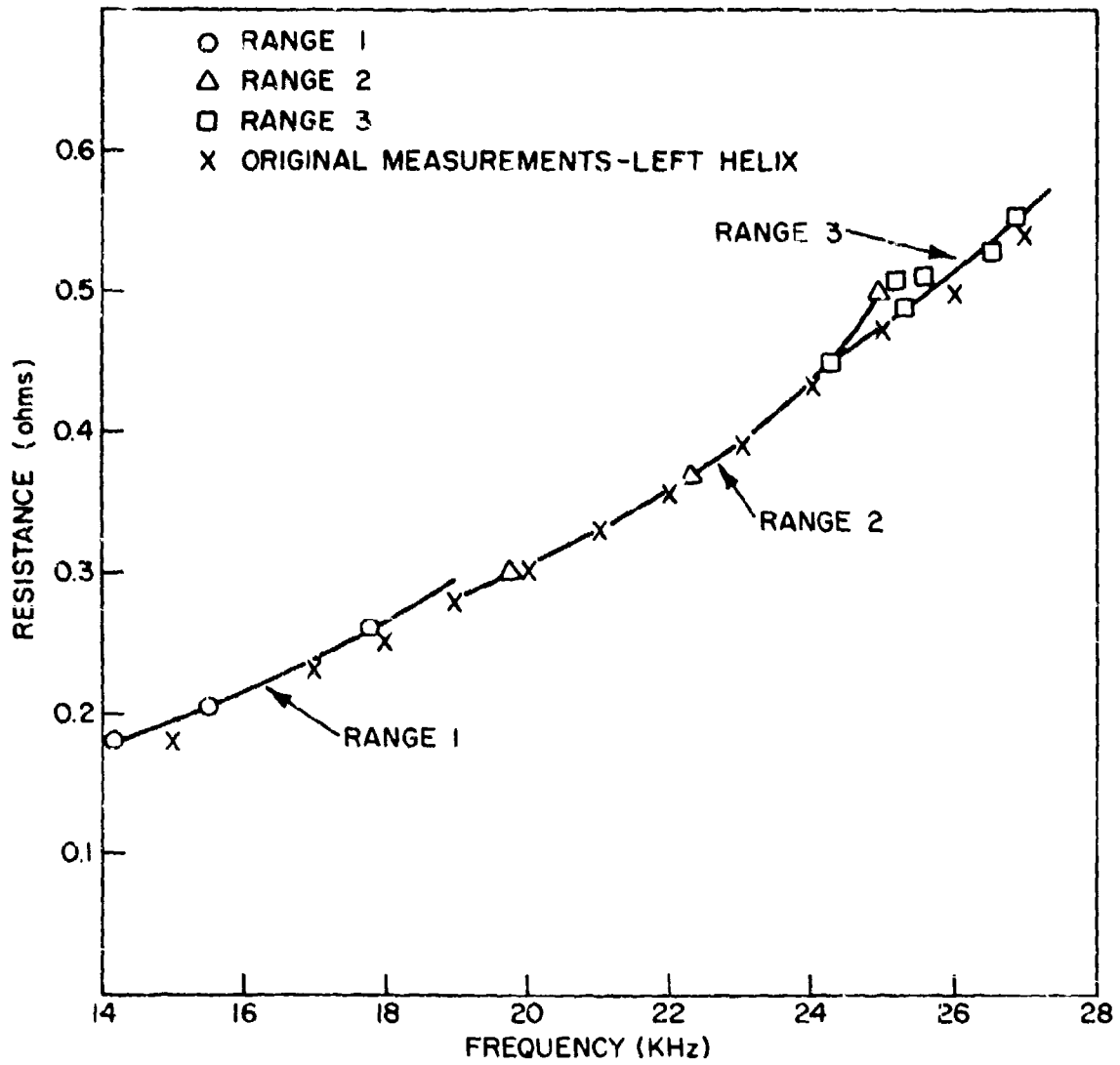

Fig. 3 - Antenna system gross resistance as a function frequency.

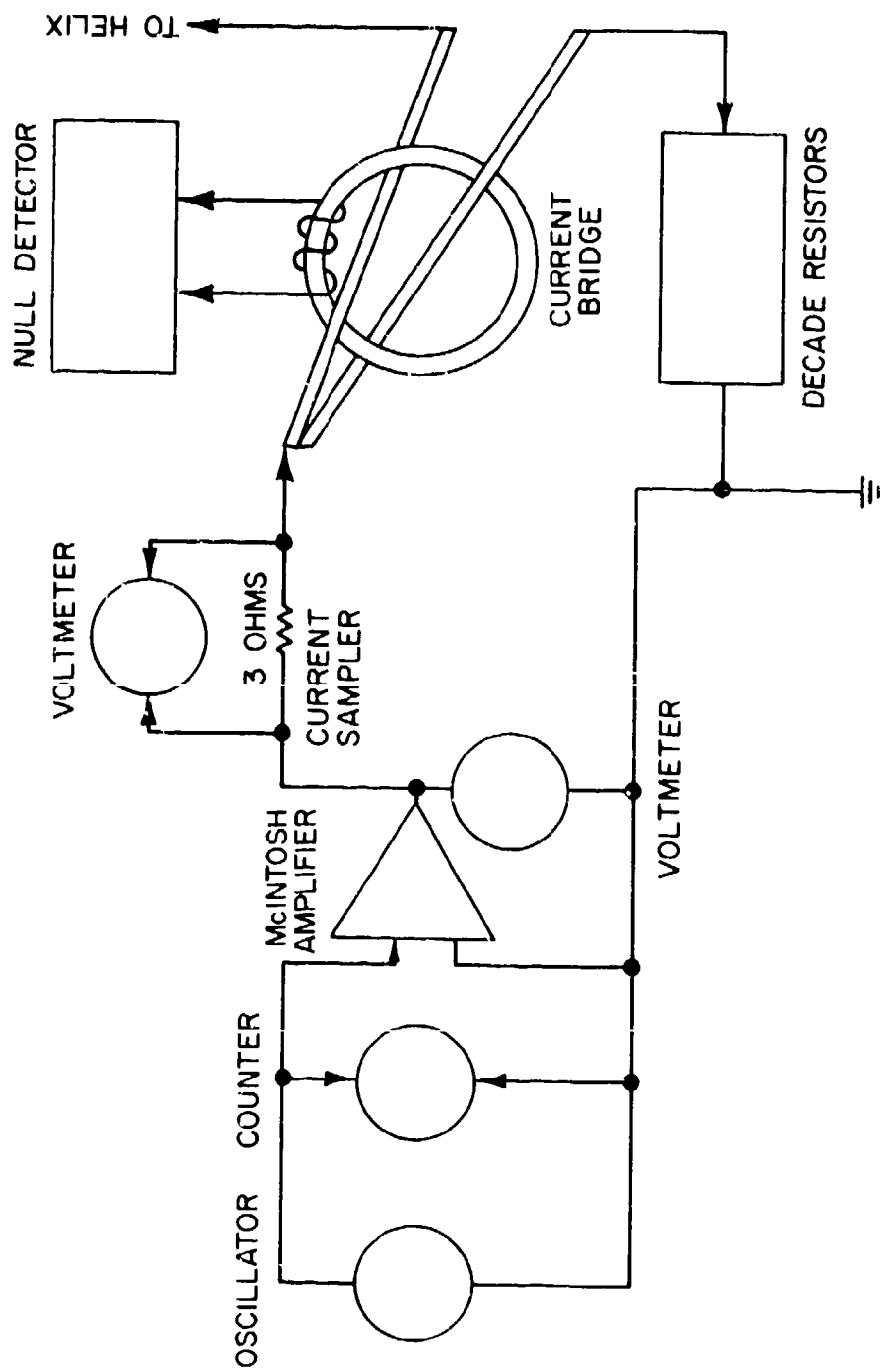

Fig. 4 - Functional diagram of the current null bridge method of measuring antenna system gross resistance.

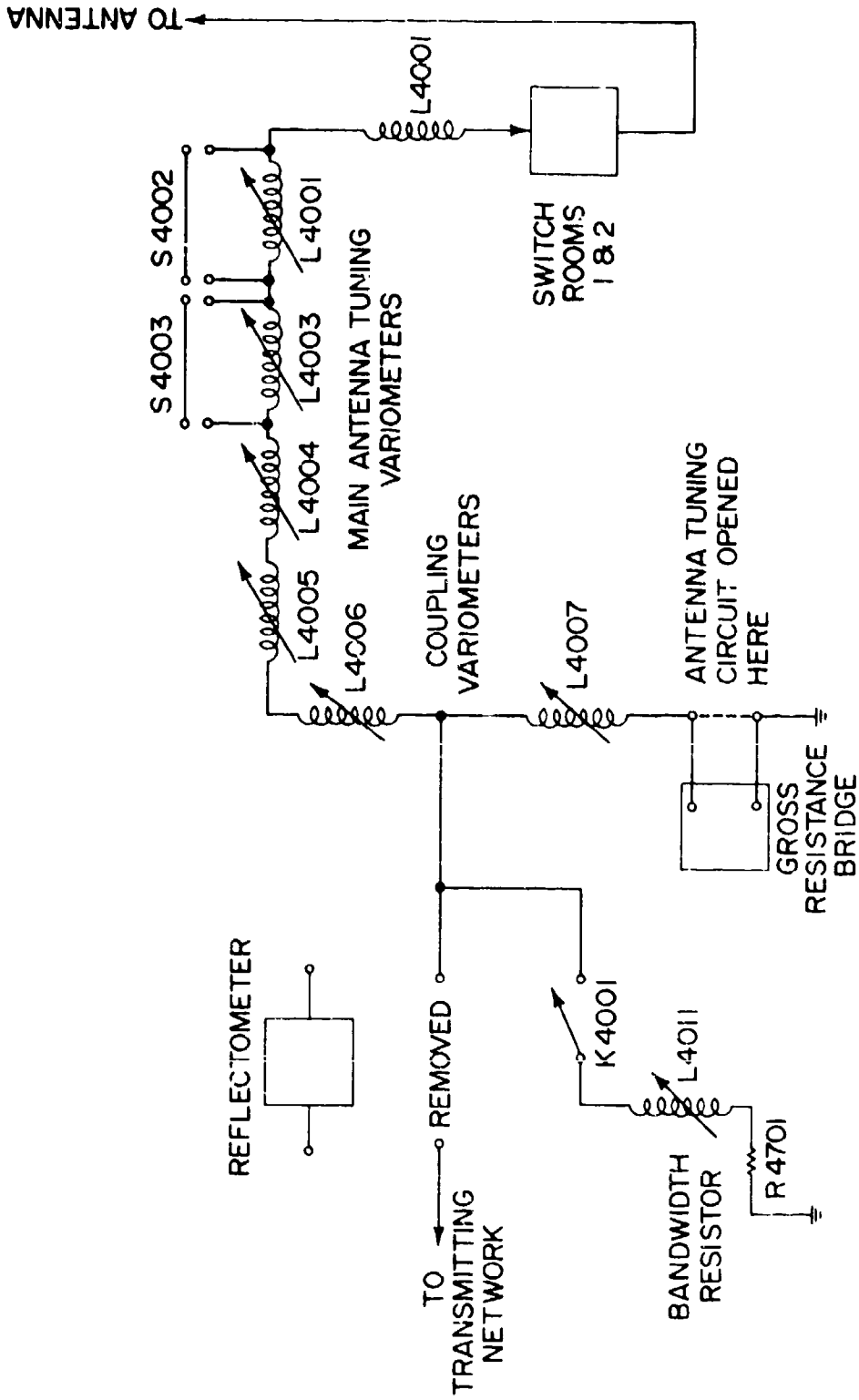
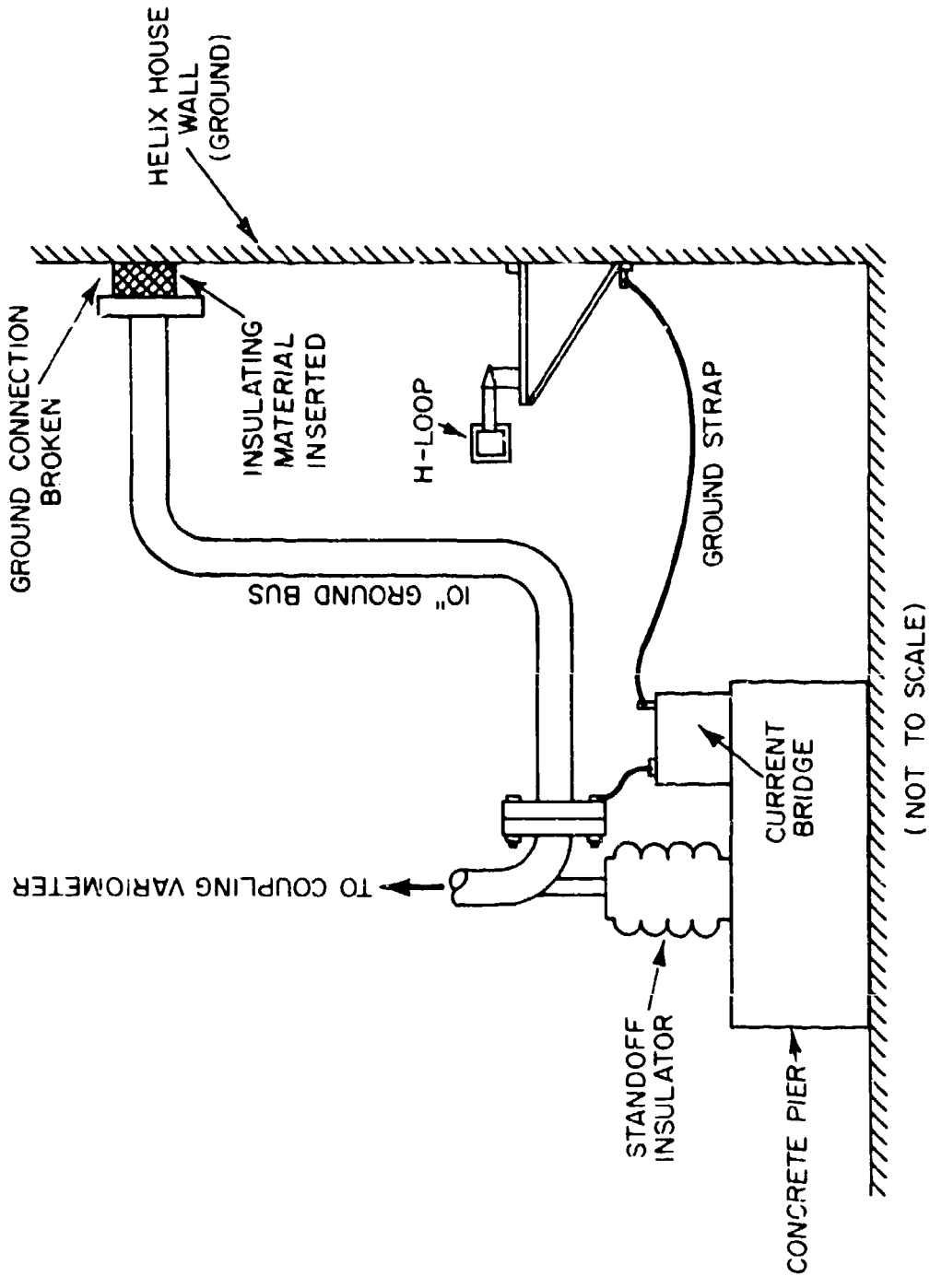

Fig. 5 - Schematic diagram showing the point of electrical connection of the gross resistance measuring bridge into the NWC antenna system.



(NOT TO SCALE)

Fig. 6 - Physical details of the connection of the current null bridge into the NWC antenna system.

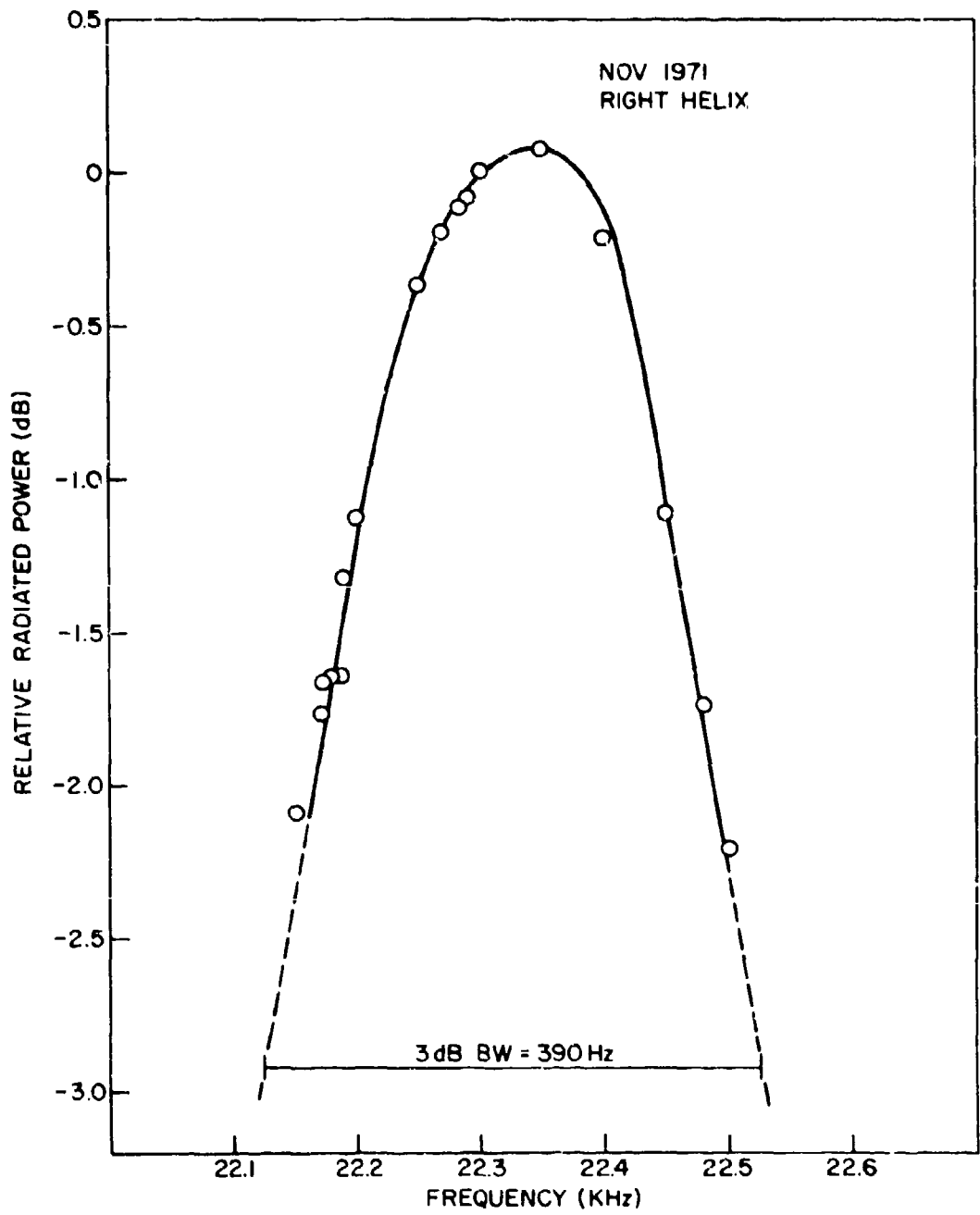

Fig. 7 - System bandwidth curve for NWC obtained by plotting radiated power as a function of frequency.

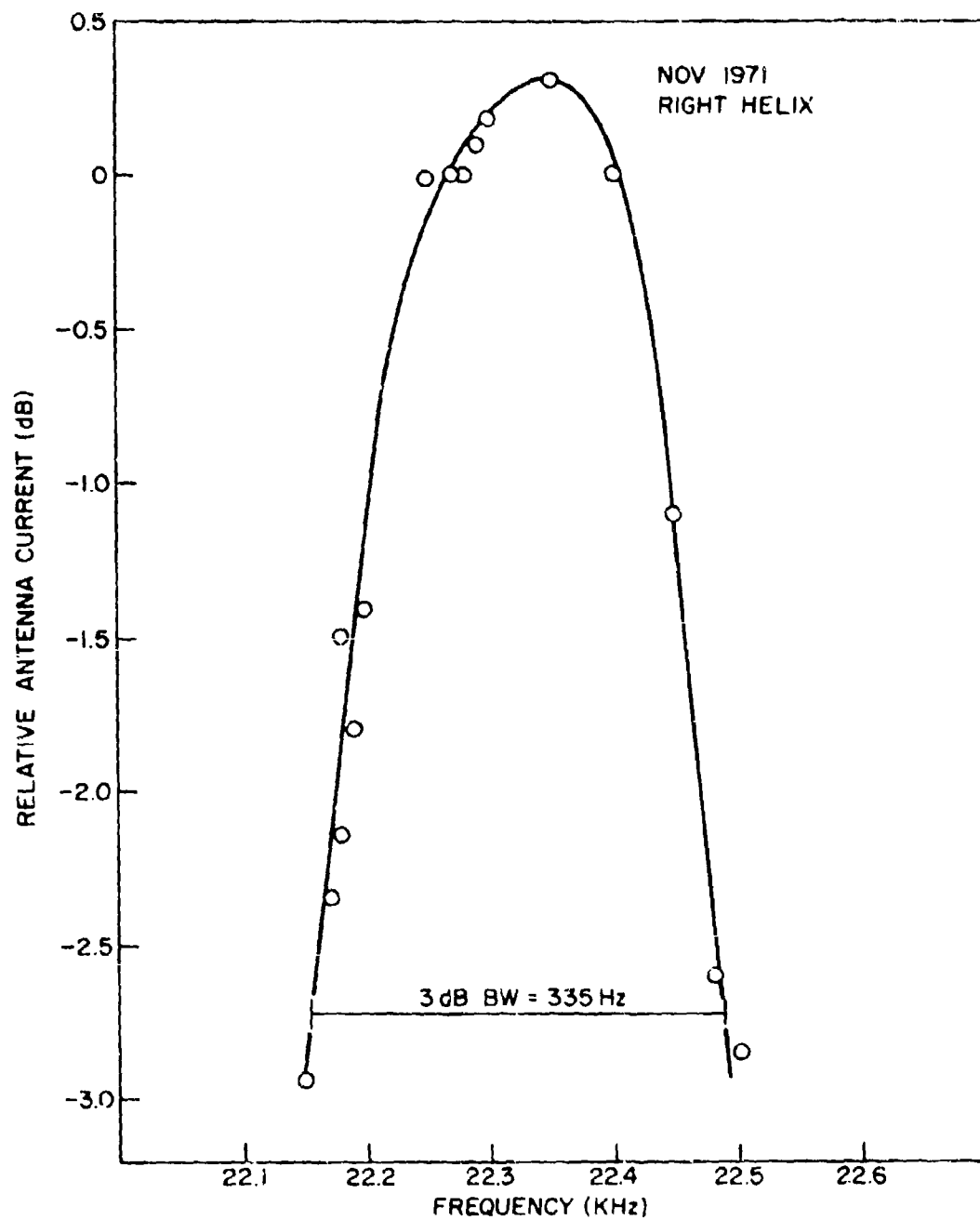

Fig. 8 - System bandwidth curve for NWC obtained by plotting antenna current as a function of frequency.