

III. SYSTEM USED AT NORTHWEST CAPE, AUSTRALIA

In the Basic Principles section VLF aeri-als, matching and coupling networks, signalling methods and bandwidth widening techniques were discussed. For any particular VLF installation all of these areas will be important, but certain areas will vary among installations. In the writing of a computer program for VLF systems numerical values must be used, at least in the checkout phase of the program.

Rather extensive data on existing U. S. Navy VLF stations, as of 1963, has been compiled.¹ However, the installation at Northwest Cape, Australia was under actual construction during the time this thesis was being written, and could be expected to incorporate the latest techniques in the VLF art. Additionally, William E. Norris, Professor of Electrical Engineering, Naval Postgraduate School, was assigned to the installation and could provide up-to-date information. Field engineers were making minor corrections and numerous measurements daily, so a great quantity of detailed information was available. For these reasons, the Northwest Cape installation was chosen as the model for the computer program.

The transmitter-antenna system was designed to operate in the frequency range from 15.5 kHz to 30 kHz, with a radiated power of 1,000 KW. Major signalling is by 50 baud Teletype, using FSK with a shift of 25 Hz and a modulation index of one. CW operation would be available on an emergency basis. The assigned operating frequency is 15.5 kHz.

Table VI shows the major system parameters of the installation, and Figures 32 through 37 show the general schematics of the various units.

TABLE VI

DESIGN PARAMETERS FOR NORTHWEST CAPE, AUSTRALIA

General	Operating Frequency	15.5 kHz
	Radiated Power	1,000 KW
Aerial	Vertical monopole, with top-hat loading	
	Effective height	628 feet
	Required efficiency	50%
	Static Capacitance	0.164 μ fd
	Downlead inductance	139.0 μ h
	Radiation resistance	0.154 ohms
	Loss resistance	0.154 ohms
	Self-resonance frequency	33.3 kHz
	Aerial bandwidth	38.125 Hz
	Bandwidth (with loss)	76.250 Hz
	Antenna current (approx.)	2550 amps
Helix	Tuning Variometer	484 μ h
	Coupling Variometer	20 μ h
	Input impedance (at resonance)	12.5 ohms
Bandwidth	Resistor	33.25 ohms
Resistor	Maximum dissipation	500 KW
	Series Variometer tuning	200 - 800 μ h

TABLE VI (continued)

Tee	Input impedance	20.0 ohms	
	Output impedance	12.5 ohms	
	Leg One Inductor	25 - 275 μ h	
	Leg Two Capacitor	.06 - .6 μ fd	
	Leg Three Inductor	50 - 300 μ h	
Transformers	Output impedance	20 ohms	
	Primary winding	430 μ h	
	Primary capacitor	0.25 μ fd	
	Secondary inductance and capacitor settings vary with number of units being used.		
	One unit	Inductance	71.5 μ h
		Capacitance	1.475 μ fd
		k	0.522
	Two units	Inductance	49.0 μ h
		Capacitance	1.076 μ fd
		k	0.474
	Three units	Inductance	35.3 μ h
		Capacitance	0.996 μ fd
		k	0.444
	Four units	Inductance	27.0 μ h
Capacitance		0.976 μ fd	
k		0.508	
Power Amplifiers	Four each AN/FRT-67 power amplifiers rated at (each)	500 KW	
	Desired plate-to-plate load	420 ohms	
Signalling	Teletype	50 baud	
	FSK, modulation index	1.0	
	Required minimum bandwidth	100 Hz	
	CW for emergency use		

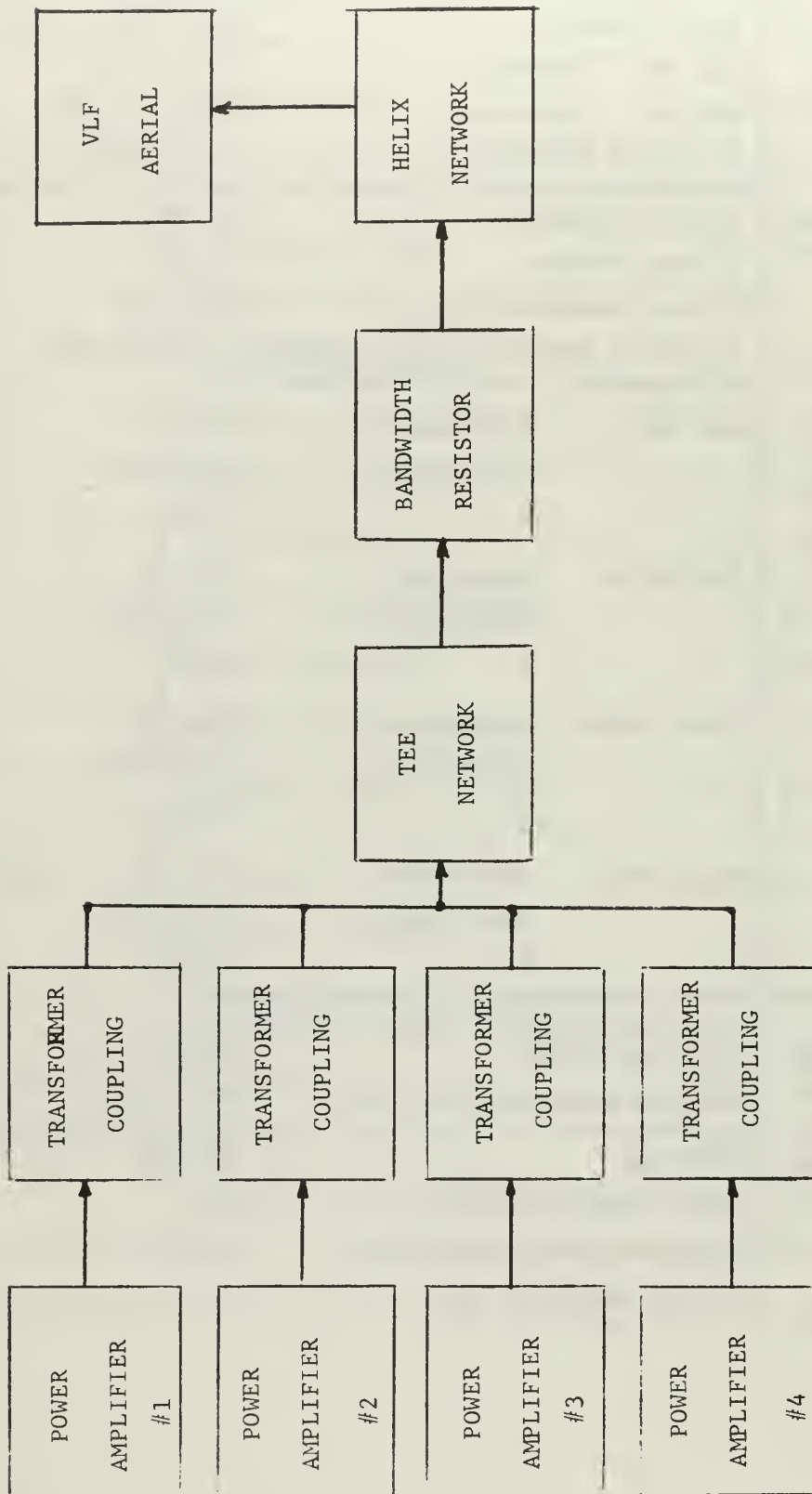

Figure 31. Block Diagram of Northwest Cape Installation

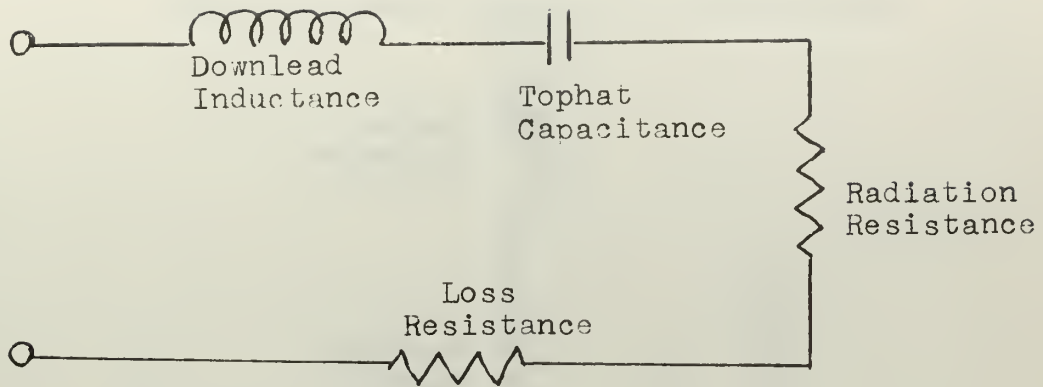

Figure 32. Aerial System

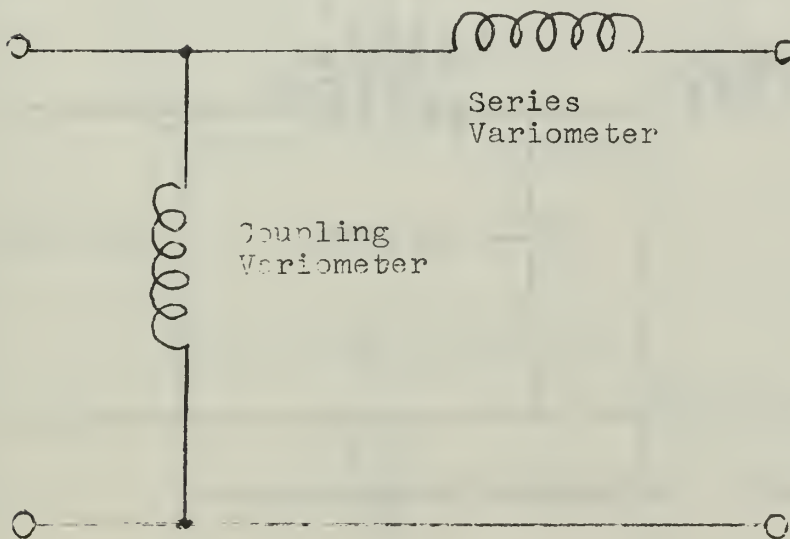

Figure 33. Helix Coupling Network

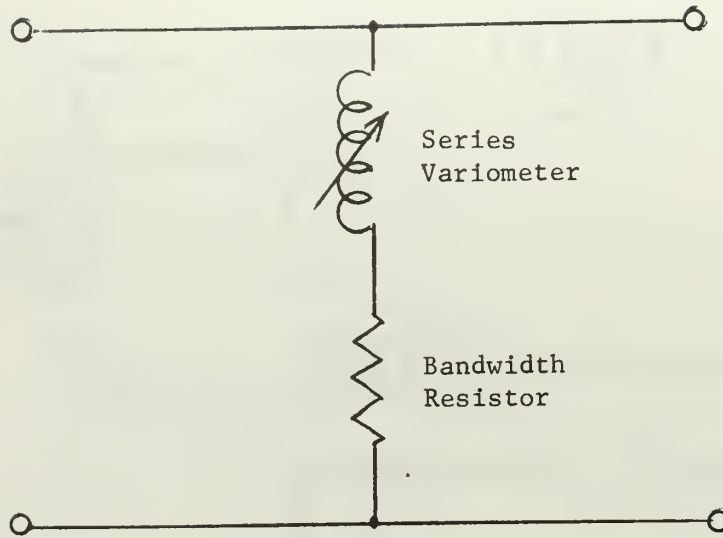

Figure 34. Bandwidth Resistor Network

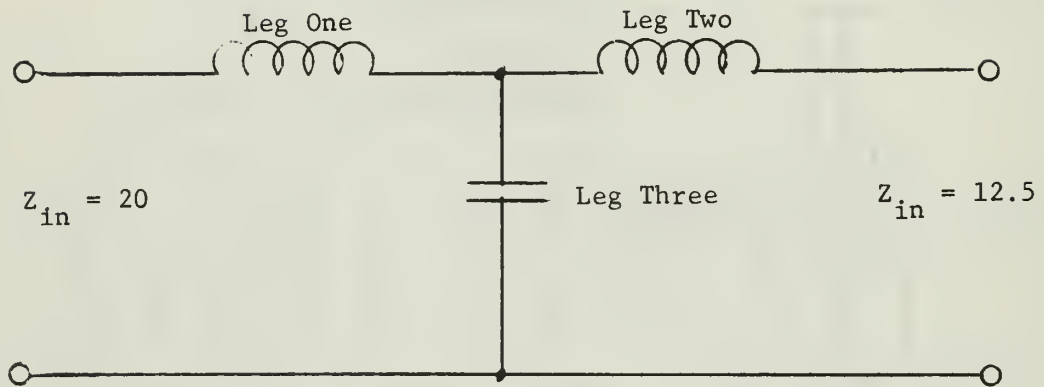
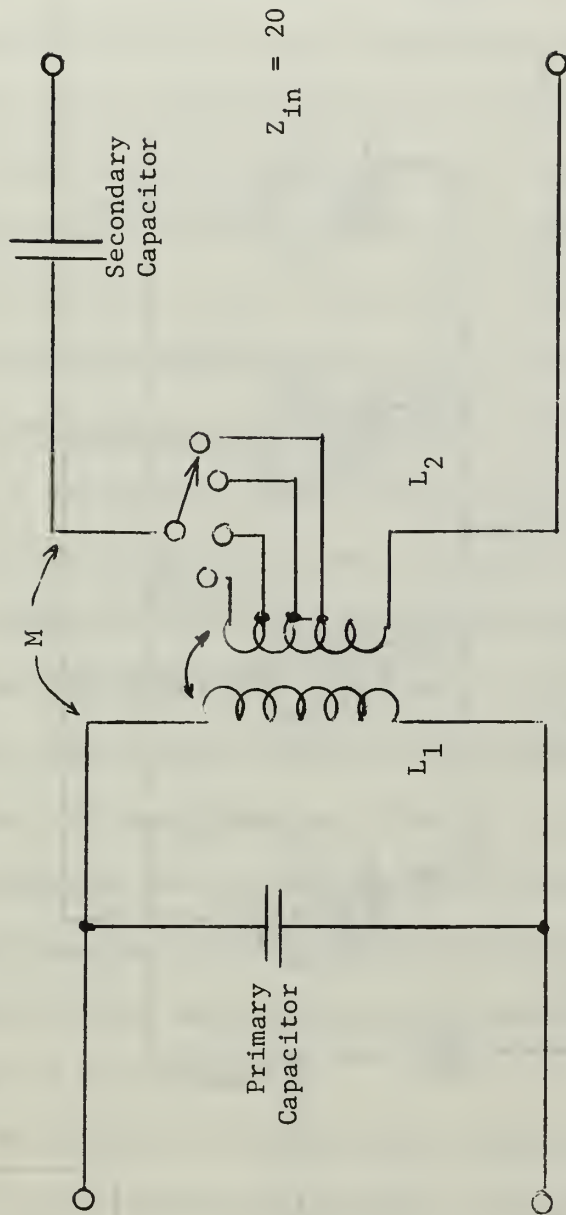

Figure 35. Tee Impedance Matching Network



Note: Transformer secondary varies with number of power amplifiers on the line.

Figure 36. Transformer Coupling

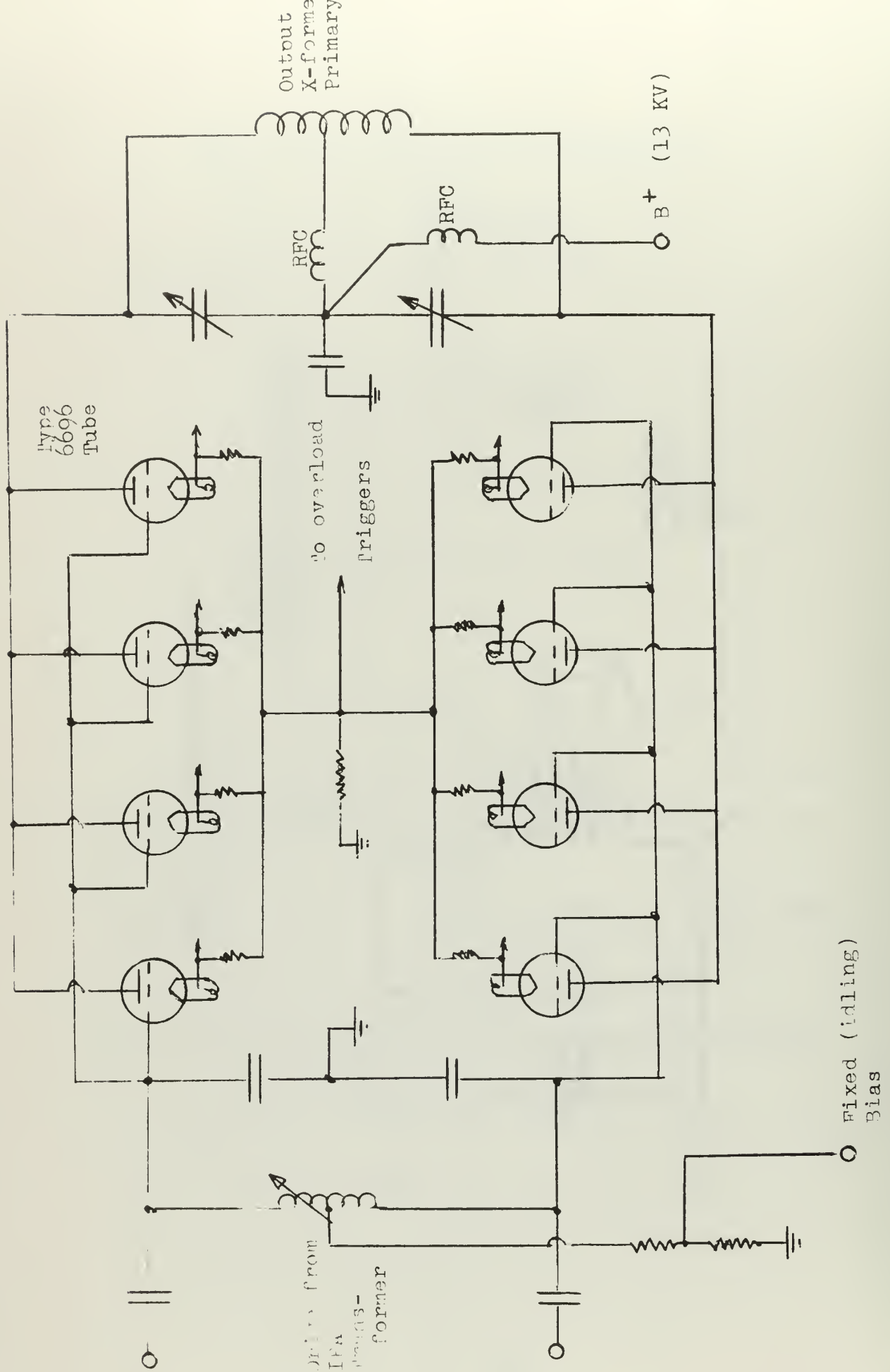

Figure 37. AN/FRT-67 Power Amplifiers